

SERVICE MANUAL

AUTO REVERSE CASSETTE DECK

SANSUI D-505R

1281

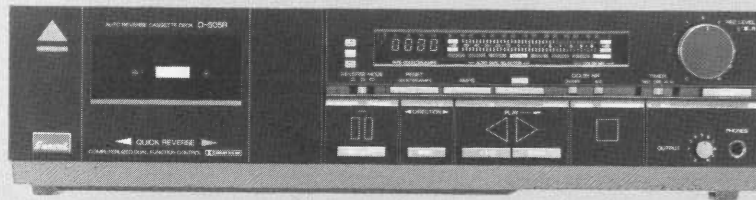

CAUTION

1. Parts identified by the Δ symbol on the schematic diagram and the parts list are critical for safety. Use only replacement parts that have critical characteristics recommended by the manufacturer.
2. Make leakage-current or resistance measurements to determine that exposed parts are acceptably insulated from the supply circuit before returning the appliance to the customer.

•SPECIFICATIONS

Track format	4-track/2-channel system
Tape speed.....	4.8 cm/sec.
Heads (2-head configuration)	
Rec/pb head.....	HIGH-Bs hard permalloy
Erase head.....	Double-gap HIGH-Bs ferrite
Motor	Capstan: Electronically Controlled DC Motor
	Reels: DC Motor
Wow/flutter	0.045% max (WRMS)
Fast forwarding (rewinding) time	
.....	Approx. 85 sec. (for C-60 tape)
Frequency response (—20 VU recording/playback)	
Normal tape (LH)	20 to 17,000 Hz (30 to 16,000 Hz \pm 3 dB)
Chrome tape	20 to 18,000 Hz (30 to 17,000 Hz \pm 3 dB)
Metal tape.....	20 to 19,000 Hz (30 to 18,000 Hz \pm 3 dB)
Signal-to-noise ratio (recording/playback with metal tape)	
DOLBY NR OFF	Better than 58 dB
DOLBY-B NR ON.....	Better than 66 dB
DOLBY-C NR ON.....	Better than 72 dB
Erase rate (metal tape)	
.....	More than 70 dB at 1 kHz
Recording bias frequency	
.....	105 kHz
Input sensitivity/Impedance	
LINE IN (REC).....	70 mV/47 kohms
Power requirements	120/220/240V 50/60 Hz
	For U.S.A. and Canada
.....	120V (60 Hz)
Power consumption	25 watts
Dimensions	430 mm (16-15/16") W 111 mm (4-3/8") H 310 mm (12-1/4") D
Weight	5.1 kg (11.2 lbs) net 6.4 kg (14.1 lbs) packed

* Design and specifications subject to changes without notice for improvements.

* Noise reduction system manufactured under license from Dolby Laboratories Licensing Corporation.
"Dolby" and the double D symbol are trade marks of Dolby Laboratories Licensing Corporation.

CAUTION

1. The symbols, UL, CSA, SA, BS, UK, EU, AS, XX <EXPORT> and XX-V <EXPORT(V)> on the parts list and the schematic diagram mean followings respectively.

UL.....	Manufactured for U.S.A market. (Underwriters Laboratories approved model.)
CSA	Manufactured for Canadian market.
SA.....	Manufactured for South African market.
BS, UK	Manufactured for United Kingdom market.
EU	Manufactured for European market.
AS.....	Manufactured for Australian market.
XX <EXPORT>	Standard Version with Inner Voltage Selector.
XX-V	<EXPORT(V)> ... Standard Version with Outer Voltage Selector.
NON MARK	Common Parts.

2. Some printed circuit boards are not supplied assembled. To separate these in this service manual, the stock numbers are not indicated for these boards. However, stock numbers for individual parts are indicated.
3. Since some capacitors and resistors are omitted from parts lists in this service manual, refer to the Common Parts List for capacitors & resistors, which was issued on February 1983.
4. Abbreviations in this service manual are as follows.

•Abbreviations List

C.R. : Carbon Resistor	E.B. : Bi-Polar Electrolytic Capacitor
S.R. : Solid Resistor	E.B.L. : Low Leakage Bi-Polar Electrolytic Capacitor
W.R. : Wire Wound Resistor	Ta.C. : Tantalum Capacitor
M.R. : Metal Film Resistor	F.C. : Film Capacitor
F.R. : Fusing Resistor	M.P. : Metallized Paper Capacitor
N.I.R. : Non-Inflammable Resistor	P.C. : Polystyrene Capacitor
R.A. : Resistor Array	C.A. : Capacitor Array
C.C. : Ceramic Capacitor	V.R. : Variable Resistor
C.T. : Ceramic Capacitor, Temperature Compensation	SW. : Switch
E.C. : Electrolytic Capacitor	Chip R. : Chip Resistor
E.L. : Low Leakage Electrolytic Capacitor	Chip C. : Chip Capacitor

Sansui

SANSUI ELECTRIC CO., LTD.

1. BLOCK DIAGRAM

1-1. Logic Control Section

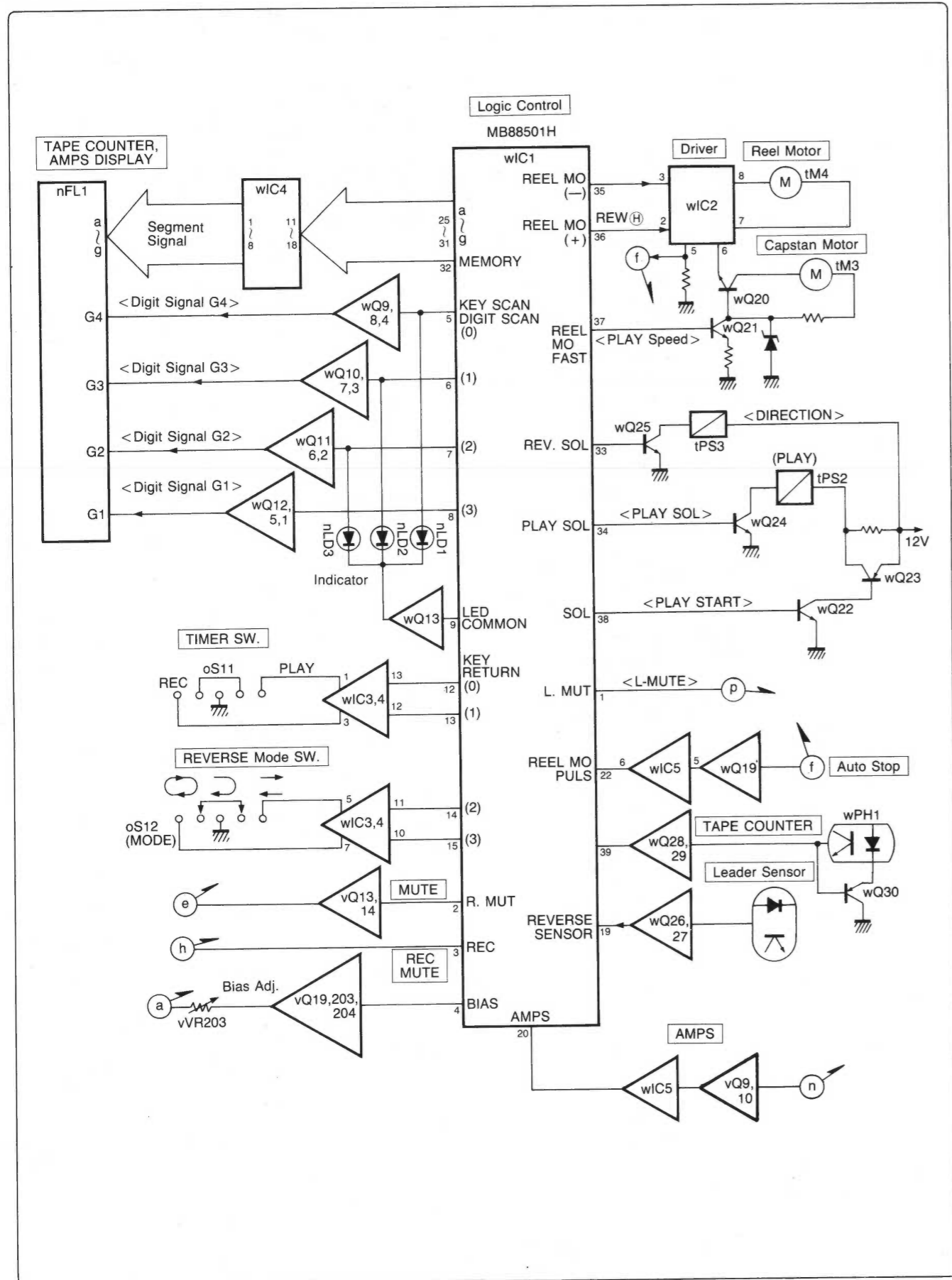

1-2. Audio Amp. Section

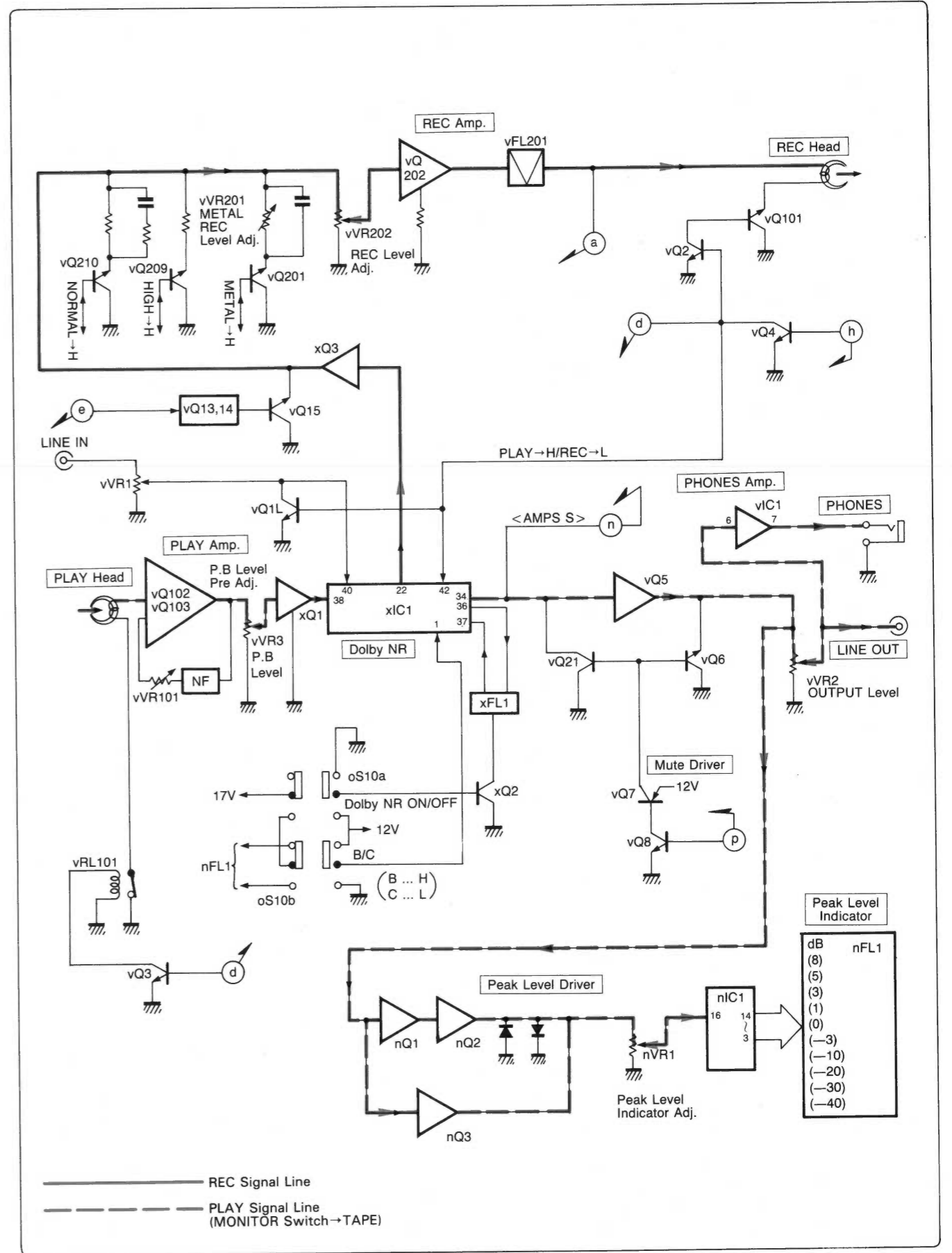

2. ADJUSTMENTS

2-1. Tape Speed Adjustment

- Note:** 1. Use Sansui Test Tape, SCT-S3K (3 kHz signal is recorded on the tape).
 2. Connections are shown in Fig. 2-1.
 3. Remove the cassette lid.
 (Refer to removal of Lid Ass'y on Page 12)
 4. Set the OUTPUT volume to be MAX position.

Fig. 2-1

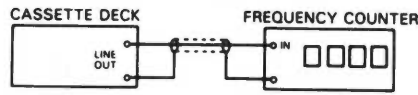
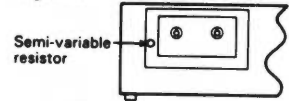

Fig. 2-2



STEP	SUBJECT	MEASURE OUTPUT	SETTING	ADJUSTMENT	ADJUST FOR	REMARKS
1.	Tape Speed Adj.	LINE OUT Frequency counter	Playback the TEST TAPE SCT-S3K	Turn semi-variable resistor as Fig. 2-2	3000Hz \pm 45Hz	Use small screw driver

2-2. Playback Adjustment

- Note:** 1. Before this adjustment, clean REC/P.B. head surface.
 2. For this adjustment, use Sansui Test Tape, SCT-F10, and SCT-L400.
 3. Set the Dolby NR switch to OFF.
 4. Set the OUTPUT volume to be MAX position.
 5. Connections are shown in Fig. 2-3.

Fig. 2-3

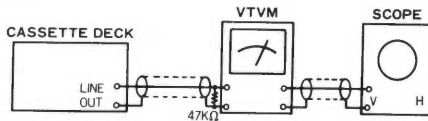
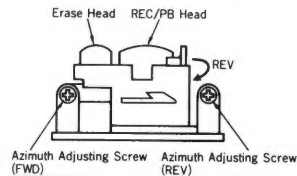
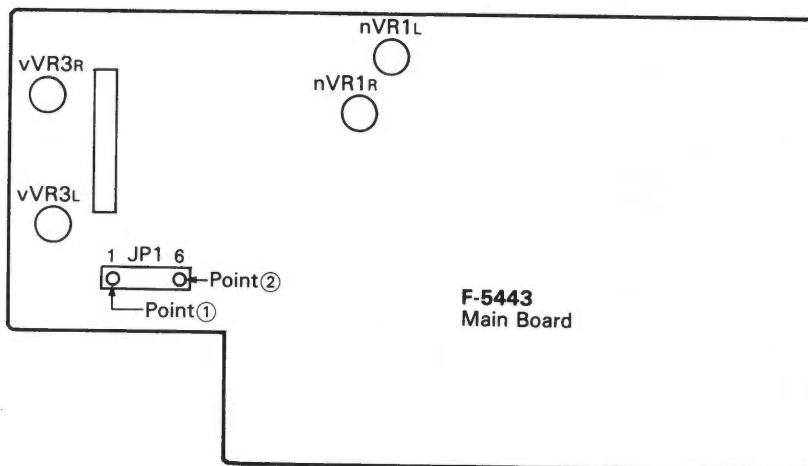

Fig. 2-4



STEP	SUBJECT	MEASURE OUTPUT	SETTING	ADJUSTMENT	ADJUST FOR	REMARKS
1.	REC/P.B. Head Adj.	LINE OUT VTVM and Scope	Playback the TEST TAPE SCT-F10K	Adjust the azimuth adjusting screw in Fig. 2-4.	MAX. Output both channels	Refer to removal of Lid Ass'y on Page 12. After this adjustment, lock the screw with paint.
2.	Playback Level Pre Adj.	Between Point ① (L-CH)/Point ② (R-CH) and GND, VTVM and Scope	Playback the TEST TAPE SCT-L400	Adjust each vVR101 (L-CH and R-CH, F-4678)	10mV \pm 2dB	Adjust this step, when replacing vVR101 (1k Ω S.V.R.) or F-4678 board are Page 7.
3.	Playback Level Adj.	LINE OUT VTVM and Scope	Playback the TEST TAPE SCT-L400	Adjust each vVR3 (L-CH and R-CH, F-5443)	500mV \pm 2dB	vVR3 (L-CH and R-CH, F-5443) are Page 3.

Fig. 2-5



2-3. REC Level & Frequency Response Adjustment

- Note:** 1. Set the BIAS volume to the mechanical center position.
 2. Set the Dolby NR switch to OFF.
 3. Set the REC LEVEL and OUTPUT volumes to be MAX position.
 4. Connections are shown in Fig. 2-6.

Fig. 2-6

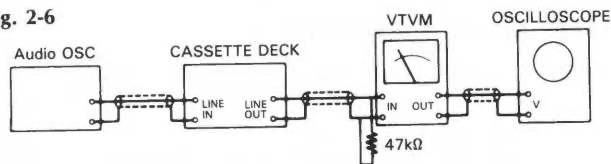

STEP	SUBJECT	INPUT SIGNAL	MEASURE OUTPUT	SETTING	ADJUSTMENT	REMARKS
1.	REC Level Adj.	Feed 1kHz from Audio S.G. into LINE IN.	LINE OUT, VTVM and Scope	Load the TEST TAPE SCT-SA. 1.Push the PAUSE, and REC knob. 2.Adjust the output level of Audio SG. for obtaining 200mV on VTVM. 3.Push the PAUSE knob, then record the 1kHz signal.	1.Adjust vVR202 (L-CH and R-CH, F-4679) until output level 200mV \pm 2dB on both channels are obtained.	vVR202 (L-CH and R-CH, F-4679) are shown in Top View on Page 13.
2.	Frequency Response Adj.	Feed 1kHz and 10kHz 10mV, from Audio S.G. into LINE IN.	Same as above	Load the TEST TAPE SCT-SA. 1.Record the 1kHz and 10kHz signals.	1.Adjust vVR203 (L-CH and R-CH, F-4679) until 1kHz and 10kHz output levels will be equal.	vVR203 (L-CH and R-CH, F-4679) are shown in Top View on Page 13.
3.	METAL REC Level Adj.	Feed 1kHz from Audio S.G. into LINE IN.	LINE OUT, VTVM and Scope	Load the TEST TAPE SCT-MA. 1.Push the PAUSE, and REC knob. 2.Adjust the output level of Audio SG. for obtaining 200mV on VTVM. 3.Push the PAUSE knob, then record the 1kHz signal.	1.Adjust vVR201 (L-CH and R-CH, F-4679) until output level 200mV \pm 2dB on both channels are obtained.	vVR201 (L-CH and R-CH, F-4679) are shown in Top View on Page 13.

2-4. Peak Level Indicator Adjustment

- Note:** 1. Set the OUTPUT volume to be MAX position.
 2. Connections are shown in Fig. 2-7.
 3. Remove the F-5443 board (Refer to removal of F-5443 board)
 4. Set the Dolby NR switch to OFF.

Fig. 2-7

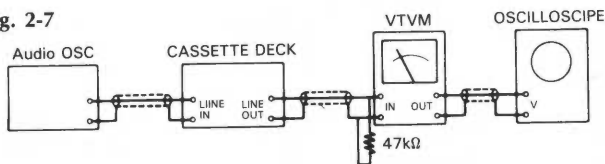

STEP	SUBJECT	INPUT SIGNAL	MEASURE OUTPUT	SETTING	ADJUSTMENT	REMARKS
1.	Peak Level Indicator Adjustment	Feed 1kHz, 100mV from S.G. into LINE IN.	LINE OUT, VTVM and Scope	Load the TEST TAPE SCT-SA. 1.Push on PAUSE, and REC knob. 2.Adjust the REC LEVEL knob for obtaining 500mV on VTVM.	1.Light the 0dB point on level indicator to adjust nVR1 (F-5443). 2.Adjust the REC LEVEL knob for obtaining 490mV on VTVM, then confirm the 0dB point on level indicator go out. 3.If not, adjust nVR1, until SETTING 1 ~ ADJUSTMENT 2 will be obtain:	nVR1 are shown in Fig. 2-3 on Page 3.

◆ List of Sansui Test Tape

Name of TEST TAPE	Recorded Frequency	Description	Equivalent To
SCT-F40	40 Hz	Playback Frequency Response Check	—
SCT-F1K	1 kHz	High Frequency Equalization Check	—
SCT-F10K	10 kHz	REC/PB Head Adjustment	—
SCT-L400N	400 Hz	Playback Level and Indicator Level Adjustment	—
SCT-S3K	3 kHz	Speed Check and Wow & Flutter Check	—
*SCT-AD (NORMAL)	—	Recording Bias Adjustment	TDK AD
*SCT-SA (HIGH)	—	REC/PB Level Adjustment	TDK SA
*SCT-MA (METAL)	—	Frequency Response Check	TDK MA

•**Note:** Some reference tapes marked * are not supplied.
 As these are equivalent to ones indicated above, please obtain these blank tapes on your side as possible.

3. OPERATIONS OF PINCH ROLLER & COMBINATION HEAD

3-1. Torque Transportation Flowchart

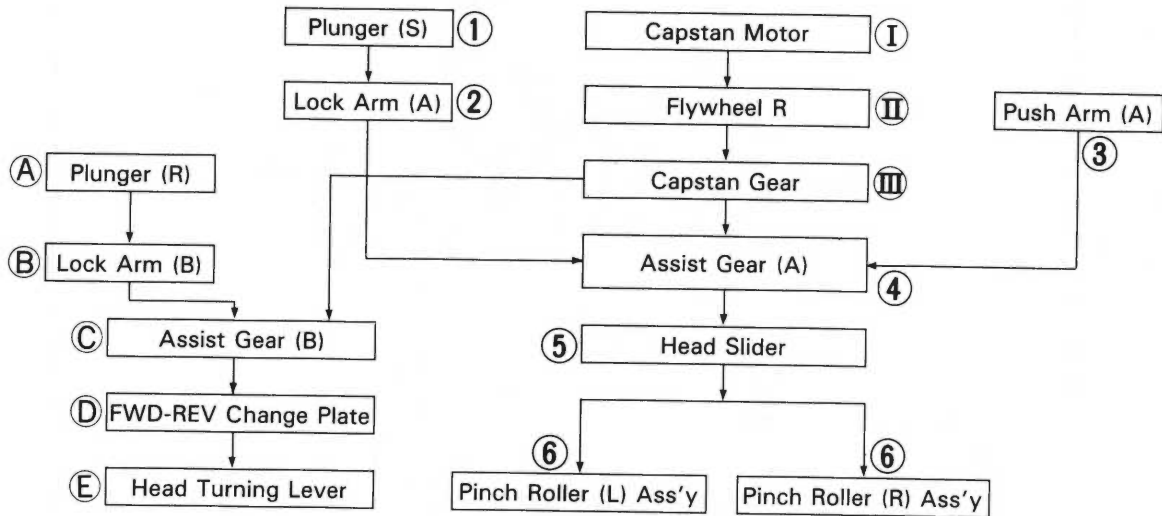

3-2. Rear View of Mechanism Chassis

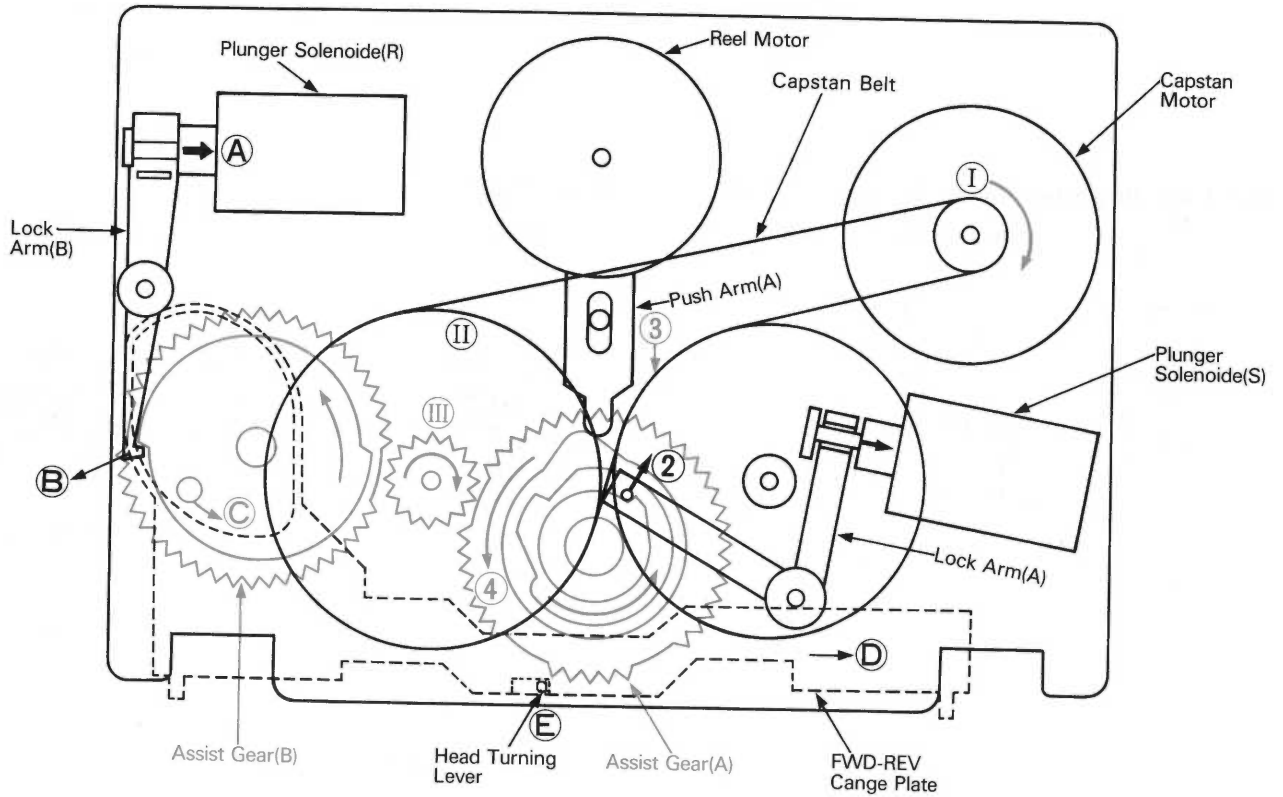

3-3. Front View of Mechanism Chassis

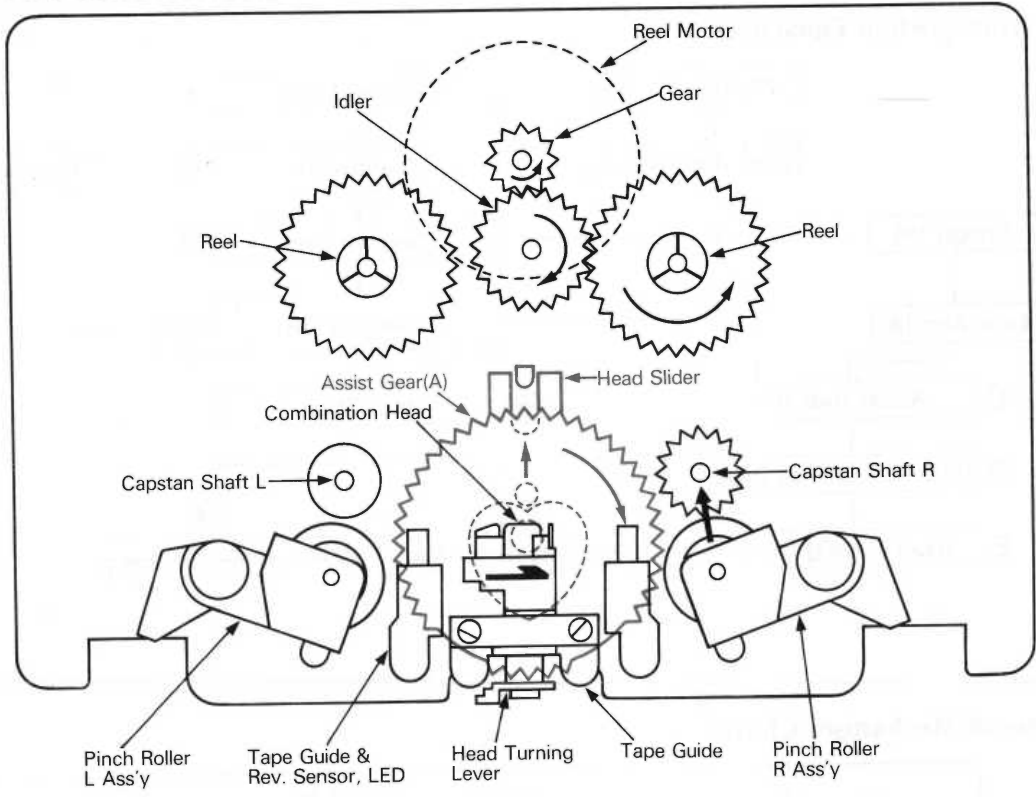

3-4. Cam Positions in the Modes of PLAY, FF, REW & STOP

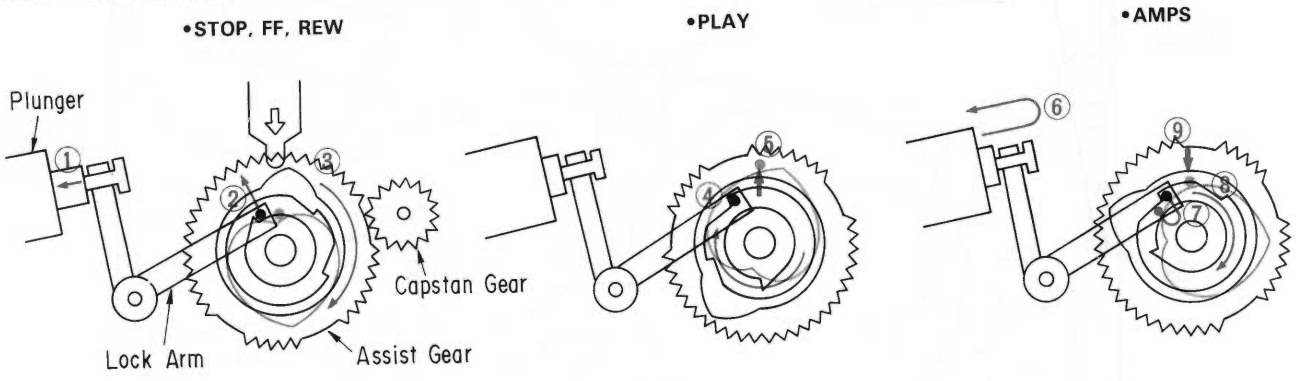

4-4. F-5339 Power SW. Board

Component Side

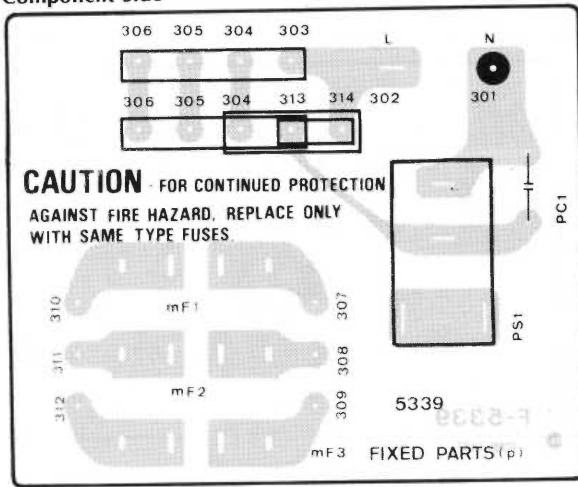

4-5. F-5444 PHONES Jack Board

Component Side

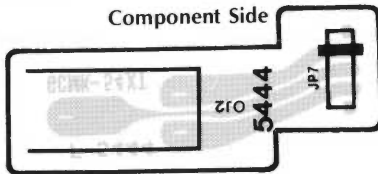

4-6. F-5445 REVERSE MODE Indicator Board

Component Side

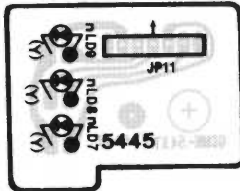

4-7. F-5446 Photo Coupler Board

Component Side



4-8. F-5447 TAPE COUNTER DISPLAY & Control SW. Board

Component Side

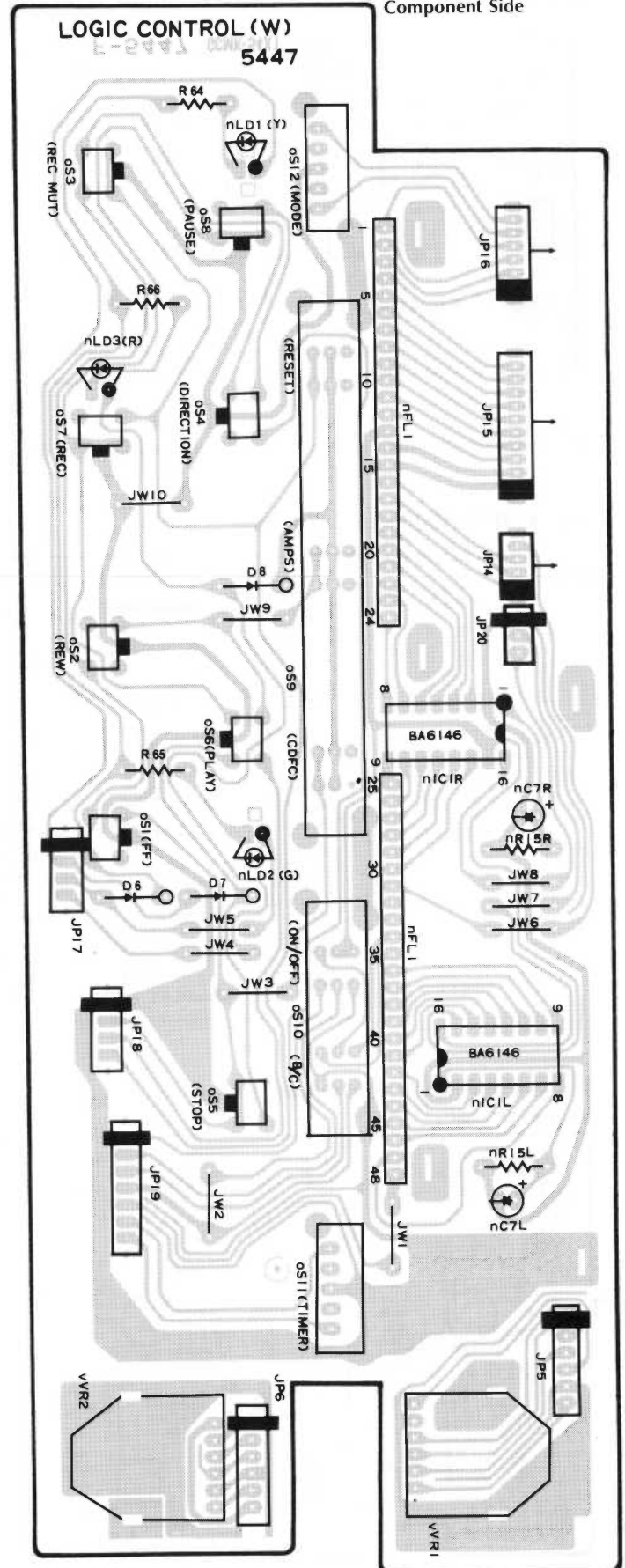

4-9. F-5443 Main Board
Component Side

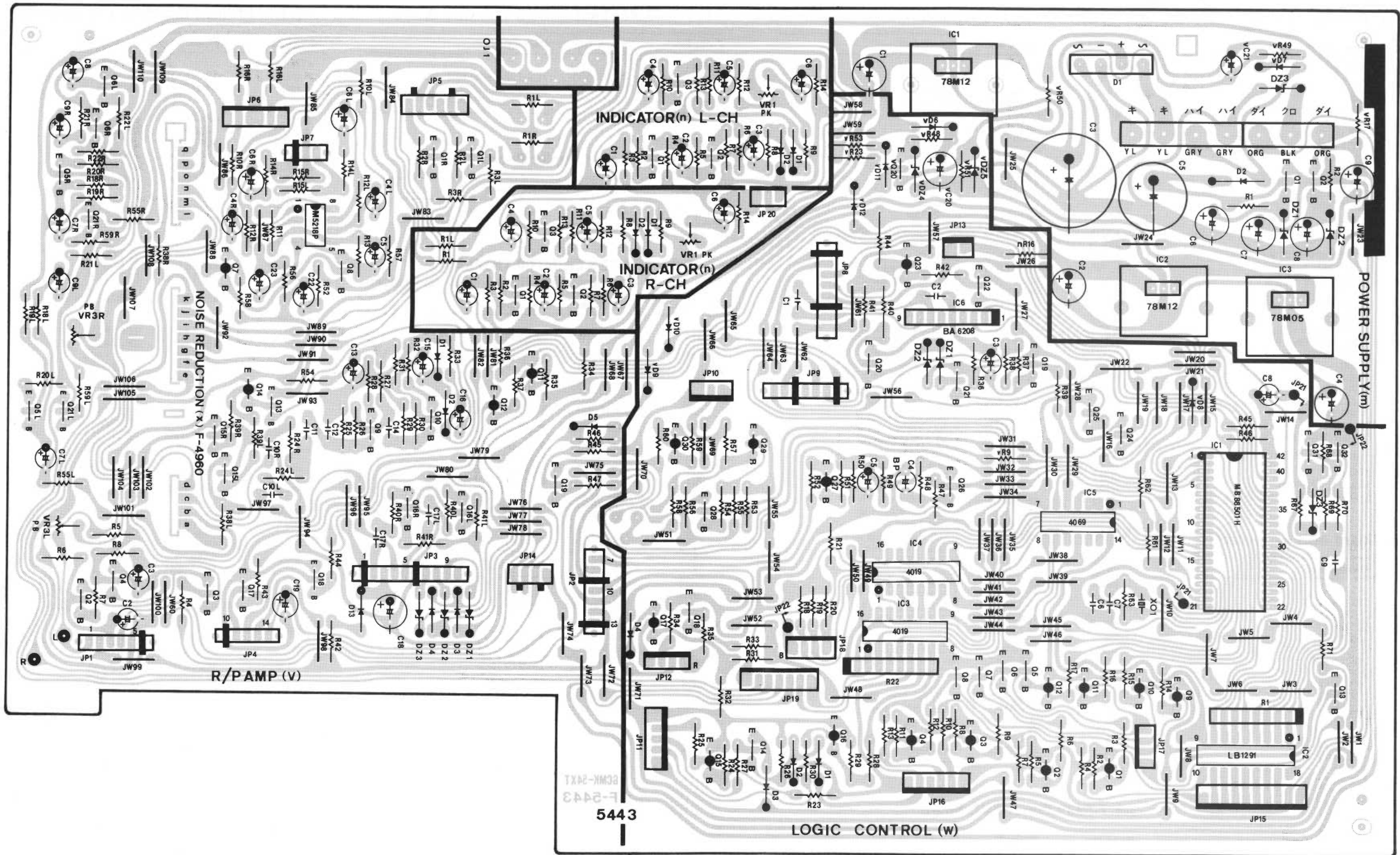

5. PARTS LIST OF BOARD

5-1. F-4678 PLAY Amp. Board (Stock No. 00992401)

Parts No.	Stock No.	Description
oPS101	46133300	Push SW.,
•Transistor		
vQ101	46359801 or 48055901	2SC2001 2SD1468S
vQ102	46577801 or 46581701	2SC2320L 2SC1845
vQ103	46577801 or 46581701	2SC2320L 2SC1845
vQ104	46367101 or 46391901 or 48058801	2SC2603 2SC2785 2SC1740S
•Diode		
vD101	46852000	RLS-73 (Chip)
vJW2	46741100	Cross Conductor (Chip)
vR101	46742800	10 Ω 1/8W Chip R.
vR102	46749200	4.7k Ω 1/8W Chip R.
vR103	46752800	150k Ω 1/8W Chip R.
vR104	46751600	47k Ω 1/8W Chip R.
vR105	46750400	15k Ω 1/8W Chip R.
vR106	46752800	150k Ω 1/8W Chip R.
vR107	46744000	33 Ω 1/8W Chip R.
vR108	46747800	1.2k Ω 1/8W Chip R.
vR109	46746800	470 Ω 1/8W Chip R.
vR110	46753000	180k Ω 1/8W Chip R.
vR111	46748600	2.7k Ω 1/8W Chip R.
vR112	46747600	1k Ω 1/8W Chip R.
vR113	46750000	10k Ω 1/8W Chip R.
vR114	46753200	220k Ω 1/8W Chip R.
vR115	46752400	100k Ω 1/8W Chip R.
vVR101	48078600	1k Ω S.V.R., P.B Level adj
vRL1	11504700 or 11504701	Relay, Relay, LR2A-12B

5-2. F-4679 REC Amp. Board (Stock No. 00992501)

Parts No.	Stock No.	Description
•Transistor		
vQ201	46367101 or 46391901 or 48058801	2SC2603 2SC2785 2SC1740S
vQ202	46367101 or 46391901 or 48058801	2SC2603 2SC2785 2SC1740S
vQ203	46614101 or 46725801	2SC3243 2SC1627A
vQ204	46614101	2SC3243
vQ205	46367101 or 46391901 or 48058801	2SC2603 2SC2785 2SC1740S
vQ206	46367101 or 46391901 or 48058801	2SC2603 2SC2785 2SC1740S
vQ209	46367101 or 46391901 or 48058801	2SC2603 2SC2785 2SC1740S
vQ210	46367101 or 46391901 or 48058801	2SC2603 2SC2785 2SC1740S
•Zener Diode		
vDZ201	46108800	05Z2.4-X
ΔvR214	46681300	10 Ω 1/4W F.R.
vC208	46658000	0.01 μ F 100V F.C.
vFL201	48363500	Trap Coil
vL201	48121500	Inductor 2.7mH
vL202	48583500	OSC Coil
vVR201	10354100	47k Ω (B) S.V.R., Metal Rec Level Adj
vVR202	10354100	47k Ω (B) S.V.R., Rec Level Adj
vVR203	10354100	47k Ω (B) S.V.R., Bias Adj

5-3. F-4960 Noise Reduction Board (Stock No. 00996901)

Parts No.	Stock No.	Description
•Transistor		
xQ1	46367101 or 46367301 or 48058801	2SC2603 2SC2458 2SC1740S
xQ2	46367101 or 46367301 or 48058801	2SC2603 2SC2458 2SC1740S
xQ3	46367101 or 46367301 or 48058801	2SC2603 2SC2458 2SC1740S
xQ4	46719900	DTC124ES
•IC		
xIC1	48179900	CX-20187
xJW1	46741100	Cross Conductor (Chip)
xJW3	46741100	Cross Conductor (Chip)
xJW4	46741100	Cross Conductor (Chip)
xJW5	46741100	Cross Conductor (Chip)
xJW6	46741100	Cross Conductor (Chip)
xJW7	46741100	Cross Conductor (Chip)
xJW8	46741100	Cross Conductor (Chip)
xJW9	46741100	Cross Conductor (Chip)
xJW11	46741100	Cross Conductor (Chip)
xJW12	46741100	Cross Conductor (Chip)
xJW13	46741100	Cross Conductor (Chip)
xJW14	46741100	Cross Conductor (Chip)
xJW15	46741100	Cross Conductor (Chip)
xR1	46753200	220k Ω 1/8W Chip R.
xR2	46748200	1.8k Ω 1/8W Chip R.
xR3	46749400	5.6k Ω 1/8W Chip R.
xR4	46749200	4.7k Ω 1/8W Chip R.
xR5	46754800	1M Ω 1/8W Chip R.
xR6	46746700	430 Ω 1/8W Chip R.
xR7	46748500	2.4k Ω 1/8W Chip R.
xR8	46749300	5.1k Ω 1/8W Chip R.
xR9	46749600	6.8k Ω 1/8W Chip R.
xR10	46747200	680 Ω 1/8W Chip R.
xR11	46751600	47k Ω 1/8W Chip R.
xR12	46748600	2.7k Ω 1/8W Chip R.
xR13	46747700	1.1k Ω 1/8W Chip R.
xR14	46754000	470k Ω 1/8W Chip R.
xR15	46752400	100k Ω 1/8W Chip R.
xR16	46750800	22k Ω 1/8W Chip R.
xR17	46749400	5.6k Ω 1/8W Chip R.
xR18	46748600	2.7k Ω 1/8W Chip R.
xR19	46745200	100 Ω 1/8W Chip R.
xR100	46748600	2.7k Ω 1/8W Chip R.
xR101	46748400	2.2k Ω 1/8W Chip R.
xC3	46794800	2700pF 50V Chip C.
xC7	46779900	560pF 50V Chip C.
xC8	46795100	4700pF 50V Chip C.
xC14	46795300	6800pF 50V Chip C.
xC15	46795500	10000pF 50V Chip C.
xC22	46778100	100pF 50V Chip C.
xFL1	48363600	DOLBY Filter
xFL2	48193300	DOLBY Filter (SQ)
xFL3	48366300	Trap Filter

5-4. F-5339 Power SW. Board

Parts No.	Stock No.	Description
ΔpC1	46943200	0.01 μ F 400V C.C.
ΔpS1	46413900	Push SW., POWER

5-5. F-5444 PHONES Jack Board

Parts No.	Stock No.	Description
oJ2	46265700	Jack,

5-6. F-5445 REVERSE MODE Indicator Board

Parts No.	Stock No.	Description
•LED		
nLD7	07251000	TLY-123, REVERSE
nLD8	07251000	TLY-123, REVERSE
nLD9	07251000	TLY-123, REVERSE

5-7. F-5446 Photo Coupler Board

Parts No.	Stock No.	Description
wPH1	48372500	Photo Interrupter GP2L04

5-8. F-5447 TAPE COUNTER DISPLAY & Control SW. Board (Stock No. 00992201)

Parts No.	Stock No.	Description
•IC		
nIC1	46671100	BA6146
nFL1	48345600	FL. Display Tube CP5262GR
•LED		
nLD1	07251000	TLY-123, PAUSE
nLD2	07250900	TLG-123A, PLAY
nLD3	46176900	TLS-123, REC
nC7	46711800	22 μ F 25V E.C.
oS1	48306900	Push SW., FF
oS2	48306900	Push SW., REW
oS3	48306900	Push SW., REC MUTE
oS4	48306900	Push SW., DIRECTION
oS5	48306900	Push SW., STOP
oS6	48306900	Push SW., PLAY
oS7	48306900	Push SW., REC
oS8	48306900	Push SW., PAUSE
oS9	48520100	Push SW., RESET, AMPS, CDFC
oS10	48315900	Push SW., DOLBY NR
oS11	46178400	Slide SW., TIMER REC, PLAY
oS12	46178400	Slide SW., REVERSE MODE
vVR1	48493100	10k Ω V.R., REC LEVEL
vVR2	48370200	10k Ω V.R., OUTPUT Level
•Diode		
wD6	03117600 or 46086000	1S2473T77 1S1588TP-3
wD7	03117600 or 46086000	1S2473T77 1S1588TP-3
wD8	03117600 or 46086000	1S2473T77 1S1588TP-3

5-9. F-5443 Main Board (Stock No. 00991801)

Parts No.	Stock No.	Description
•Transistor		
mQ1	48581701	2SD438
mQ2	48581701	2SD438
•IC		
ΔmIC1	48470100 or 48566000	μ PC78M12H AN78M12
ΔmIC2	48470100 or 48566000	μ PC78M12H AN78M12
ΔmIC3	07183500 or 48565400	μ PC78M05H AN78M05
•Diode		
ΔmD1	03117000	RB152-LFF
ΔmD2	03117700	10E-2
•Zener Diode		
mDZ1	46116000	05Z24-Y
mDZ2	46115100	05Z18-Y
mDZ3	46111800	05Z6.2-Y
mC3	46168700	3300 μ F 35V E.C.
•Transistor		
nQ1	46367101 or 46367301 or 48058801	2SC2603 2SC2458 2SC1740S
nQ2	46367101	2SC2603
nQ3	46367101	2SC2603
•Diode		
nD1	03117600 or 46086000	1S2473T77 1S1588TP-3
nD2	03117600 or 46086000	1S2473T77 1S1588TP-3
nVR1	48199900	100k Ω (B) S.V.R., Level indicator
oJ1	46371500	4P Terminal, LINE IN·OUT
•Transistor		
vQ1	46367101 or 46367301 or 48058801	2SC2603 2SC2458 2SC1740S
vQ2	46367101 or 46367301 or 48058801	2SC2603 2SC2458 2SC1740S
vQ3	46367101 or 46367301 or 48058801	2SC2603 2SC2458 2SC1740S
vQ4	46367101 or 46367301 or 48058801	2SC2603 2SC2458 2SC1740S
vQ5	46367101	2SC2603
vQ6	46367101 or 46367301 or 48058801	2SC2603 2SC2458 2SC1740S
vQ7	48183400	DTA114YS
vQ8	46367101 or 46367301 or 48058801	2SC2603 2SC2458 2SC1740S
vQ9	46367101 or 46367301 or 48058801	2SC2603 2SC2458 2SC1740S
vQ10	46367101 or 46367301 or 48058801	2SC2603 2SC2458 2SC1740S
vQ11	46367001 or 46392001	2SA1115 2SA1115
vQ12	46367001 or 46392001	2SA1115 2SA1115
vQ13	48171600	DTC114YS
vQ14	48183400	DTA114YS
vQ15	46367101 or 46367301 or 48058801	2SC2603 2SC2458 2SC1740S
vQ16	46367101 or 46367301 or 48058801	2SC2603 2SC2458 2SC1740S
vQ17	46367101 or 46367301 or 48058801	2SC2603 2SC2458 2SC1740S

<F-5443>

Parts No.	Stock No.	Description
vQ18	46367101 or 46367301 or 48058801	2SC2603 2SC2458 2SC1740S
vQ19	46367101 or 46367301 or 48058801	2SC2603 2SC2458 2SC1740S
vQ20	46367001 or 46392001	2SA1115 2SA1175
vQ21	46367101 or 46367301 or 48058801	2SC2603 2SC2458 2SC1740S
•IC		
vIC1	46673800	M5218P
•Diode		
vD1	03117600 or 46086000	1S2473T77 1S1588TP-3
vD2	03117600 or 46086000	1S2473T77 1S1588TP-3
vD3	03117600 or 46086000	1S2473T77 1S1588TP-3
vD4	03117600 or 46086000	1S2473T77 1S1588TP-3
vD5	03117600 or 46086000	1S2473T77 1S1588TP-3
vD6	03117600 or 46086000	1S2473T77 1S1588TP-3
vD7	03117600 or 46086000	1S2473T77 1S1588TP-3
vD8	03117600 or 46086000	1S2473T77 1S1588TP-3
vD9	03117600 or 46086000	1S2473T77 1S1588TP-3
vD10	03117600 or 46086000	1S2473T77 1S1588TP-3
vD11	03117600 or 46086000	1S2473T77 1S1588TP-3
vD12	03117600 or 46086000	1S2473T77 1S1588TP-3
vD13	03117600 or 46086000	1S2473T77 1S1588TP-3
•Zener Diode		
vDZ1	46112600 or 46112700 or 46112800	05Z8.2-X 05Z8.2-Y 05Z8.2-Z
vDZ2	46112600 or 46112700 or 46112800	05Z8.2-X 05Z8.2-Y 05Z8.2-Z
vDZ3	46112600 or 46112700 or 46112800	05Z8.2-X 05Z8.2-Y 05Z8.2-Z
vDZ4	46113300	05Z10-Y
vDZ5	46113900	05Z12-Y
vR4	46681300	10 Ω 1/4W F.R.
vR17	46682500	100 Ω 1/4W F.R.
vR42	46682900	220 Ω 1/4W F.R.
vVR3	46634100 or 48199500	4.7k Ω S.V.R., PB Level Adj 5k Ω (B) S.V.R., PB Level Adj
•Transistor		
wQ1	46367001 or 46392001	2SA1115 2SA1175
wQ2	46367001 or 46392001	2SA1115 2SA1175
wQ3	46367001 or 46392001	2SA1115 2SA1175
wQ4	46367001 or 46392001	2SA1115 2SA1175
wQ5	46719900	DTC124ES
wQ6	46719900	DTC124ES
wQ7	46719900	DTC124ES
wQ8	46719900	DTC124ES
wQ9	46367001 or 46392001	2SA1115 2SA1175
wQ10	46367001 or 46392001	2SA1115 2SA1175

Parts No.	Stock No.	Description
wQ11	46367001 or 46392001	2SA1115 2SA1175
wQ12	46367001 or 46392001	2SA1115 2SA1175
wQ13	46359801 or 48055901	2SC2001 2SD1468S
wQ14	46367101 or 46367301 or 48058801	2SC2603 2SC2458 2SC1740S
wQ15	46367001 or 46392001	2SA1115 2SA1175
wQ16	46367001 or 46392001	2SA1115 2SA1175
wQ17	46367001 or 46392001	2SA1115 2SA1175
wQ18	46367101 or 46367301 or 48058801	2SC2603 2SC2458 2SC1740S
wQ19	46367101 or 48058801	2SC2603 2SC1740S
wQ20	46614101	2SC3243
wQ21	46367101 or 46367301 or 48058801	2SC2603 2SC2458 2SC1740S
wQ22	46367101 or 46367301 or 48058801	2SC2603 2SC2458 2SC1740S
wQ23	46359701	2SA952
wQ24	46359801 or 48055901	2SC2001 2SD1468S
wQ25	46359801 or 48055901	2SC2001 2SD1468S
wQ26	46367101 or 46367301 or 48058801	2SC2603 2SC2458 2SC1740S
wQ27	46367001	2SA1115
wQ28	46367101 or 46367301 or 48058801	2SC2603 2SC2458 2SC1740S
wQ29	46367001	2SA1115
wQ30	46367001	2SA1115
wQ31	46367101 or 46367301 or 48058801	2SC2603 2SC2458 2SC1740S
wQ32	46367101 or 46367301 or 48058801	2SC2603 2SC2458 2SC1740S
•IC		
wIC1	48499800	MB88501H
wIC2	46671500	LB1291
wIC3	46209500 or 48075200	MSM4019RS LC4019B
wIC4	46209500 or 48075200	MSM4019RS LC4019B
wIC5	46427000 or 48063900	μ PD4069UBC BU4069UB
wIC6	46149600	BA6208
wXO1	48241600	Ceramic OSC Element KBR 4.0MS
•Diode		
wD1	03117600 or 46086000	1S2473T77 1S1588TP-3
wD2	03117600 or 46086000	1S2473T77 1S1588TP-3
wD3	03117600 or 46086000	1S2473T77 1S1588TP-3
wD4	03117600 or 46086000	1S2473T77 1S1588TP-3
•Zener Diode		
wDZ1	46110900	05Z4.7-Y
wDZ2	46111800	05Z6.2-Y
wDZ3	46109400	05Z3.0-Y
wR1	46348900	4.7k Ω X8 1/8W A.R.
wR22	46348900	4.7k Ω X8 1/8W A.R.
wC4	48102000	10 μ F 16V E.B.

6. MAIN PARTS REPLACEMENT (See Exploded View on page 15)

A. Bonnet (See Fig. 6-1)

- 1) Remove two screws (SA).
- 2) Pull the rear side of the bonnet and then remove it.

B. Bottom Plate (See Fig. 6-1)

- 1) Remove six screws (SB, SC).
- 2) Pull the rear side of the bottom plate and then remove it.

Fig. 6-1

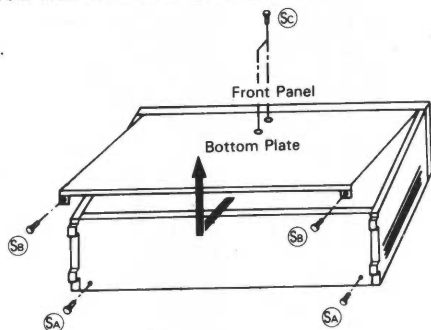

C. Side Panel L (or R) (See Fig. 6-2)

- 1) Remove the bonnet and bottom plate.
- 2) Shift the position of the side panel L (or R) 2.0cm into the arrow direction (1).
- 3) Undo the hooks (2) of the side panel and then pull it to the arrow direction (3) to remove it.

Fig. 6-2

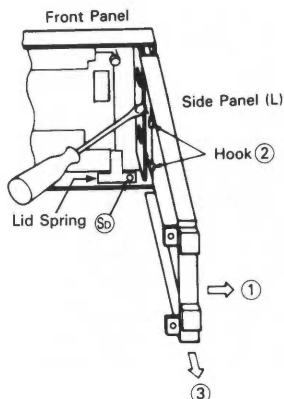

D. Lid Spring (See Fig. 6-2)

- 1) Remove left side panel.
- 2) Loosen the screw (SD) to pluck out spring holder ass'y.

E. Damper Ass'y (See Top View on page 13)

- 1) Remove the bonnet and bottom plate
- 2) Remove three screws (SE, SF).
- 3) Take out the fixing board with damper ass'y.
- 4) Remove screw (SG).

Fig. 6-3

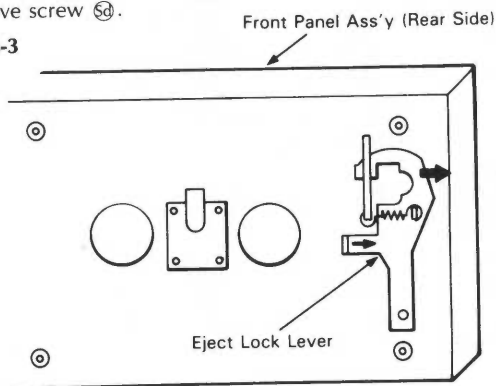

F. Lid Ass'y

Press the " " mark to open the cassette holder, push the parts locked at the left and right in Fig. 6-4 while pulling it upward, and remove the lid ass'y.

Fig. 6-4

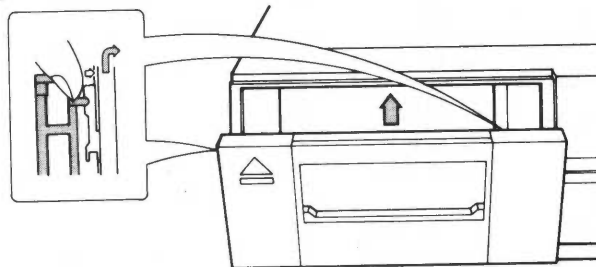

G. REC/PB Head and Erase Head (22-1) (See Page 15)

- 1) Remove the mechanism ass'y from set.
- 2) Loosen two screws (22-4).
- 3) Pull out the head toward the arm ass'y (13), softly.
- 4) Unsolder head wires at head terminal board.

Note: Care must be take not to given tension.

H. F-4678 and F-4679 Circuit Board

- 1) Remove the bonnet and the bottom plate.
- 2) Pluck out two connectors from F-4678 circuit board.
- 3) Unhook two stopper lid of sockets on the F-4679 circuit board and the pull out two parallel cables.
- 4) Remove the protection cover on the F-4678 circuit board.
- 5) Unsolder heads, LED and sensor read wires.
- 6) Loosen two screws fixing F-4678 circuit board and then undo two hooks near S.V.R. on the F-4679 circuit board.

I. Mechanism Ass'y (See Top View on Page 13)

- 1) Remove the bonnet, the bottom plate and the side panel L.
- 2) Pulck out two connectors from F-3748 board.
- 3) Unhook two stopper lid sockets on the F-4679 circuit board and then pull out three parallel cables.
- 4) Extract two connectors from the F-4678 circuit board.
- 5) Remove the screws (SH, SH).
- 6) Take out the fixing board with damper ass'y.
- 7) Loosen two screws (SH) to remove mechanism ass'y.
- 8) Take out the mechanism ass'y.

Note: To attach the mechanism ass'y, push the eject lock lever to the arrow direction as Fig. 6-3.

7. OTHER PARTS

7-1. Front View

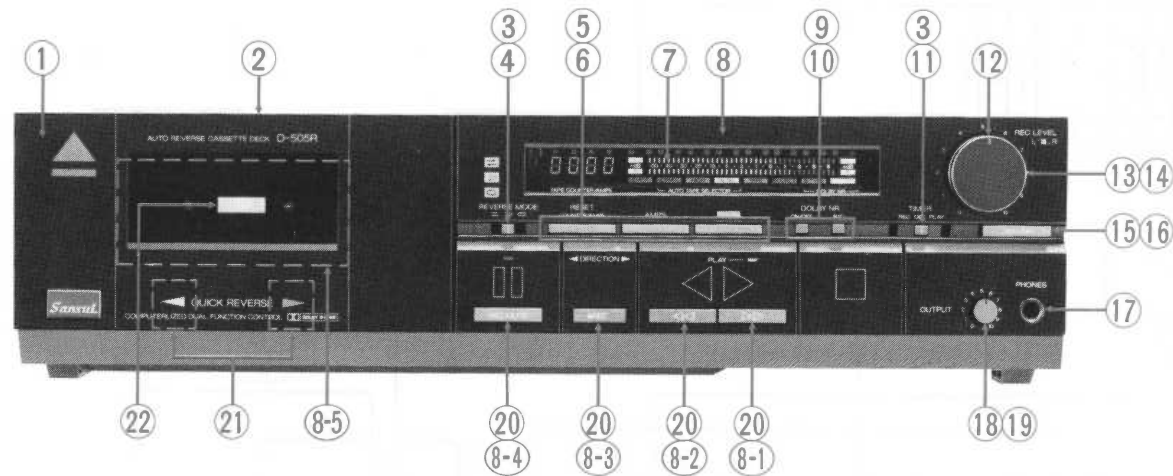

Parts List

Parts No.	Stock No.	Description
1	27262800	Lid Ass'y
2	27305300	Bonnet
3	46178400	Slide SW., REVERSE MODE, TIMER
4	27251100	Slide Knob, REVERSE MODE, TIMER
5	48520100	Push SW., RESET, AMPS, CDFC.
6	27150500	Push Knob, RESET, AMPS, CDFC.
7	48345600	FL, Display Tube
8	27262900	Front Panel Ass'y (XX-V, CSA, EU, UK)
	27277600	Front Panel Ass'y (UL)
8-1	27133300	Push Knob, FF
8-2	27133400	Push Knob, REW
8-3	27159210	Push Knob, REC
8-4	27133510	Push Knob, REC MUTE
8-5	27141520	Cassette Holder Ass'y
9	48315900	Push SW., DOLBY NR
10	27150400	Push Knob, DOLBY NR
11	27127700	Slide Knob, DOLBY NR
12	48370200	10kΩ V.R., REC LEVEL
13	27127800	Knob, REC LEVEL (L)
14	27127900	Knob, REC LEVEL (R)
△ 15	46413900	Push SW., POWER (XX-V, UL, EU, UK)
△	48065200	Push SW., POWER (CSA)
16	27127610	Power Knob, POWER
17	46265700	Jack, PHONES
18	48493100	10kΩ V.R., OUTPUT
19	27128000	Knob, OUTPUT
20	48306900	Push SW., FF, REW, REC, MUTE, REC
21	48587000	LED Ass'y (SLF-401C-06)
22	48389900	LED Ass'y (SLF-401C)
	27303800	Lid Spring

7-2. Top View

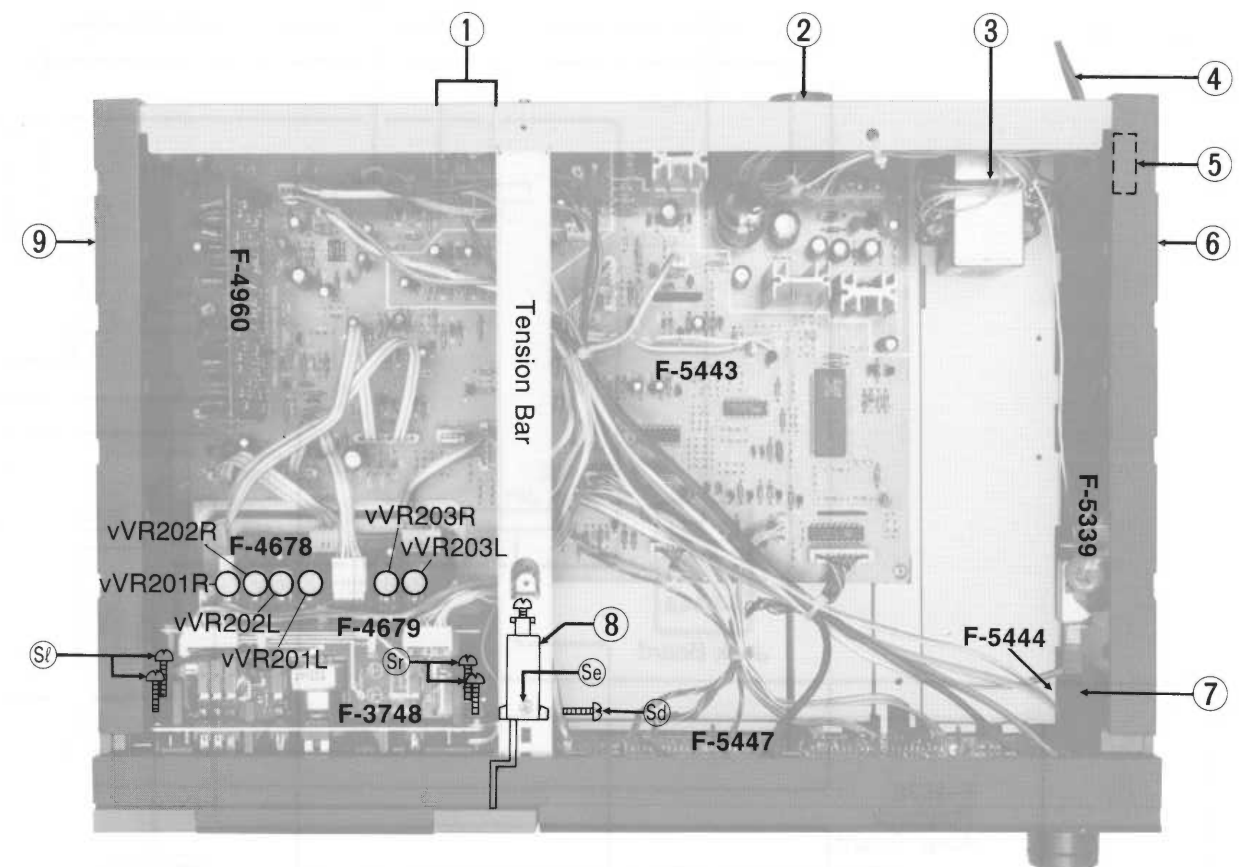

Parts List

Parts No.	Stock No.	Description
1	46371500	4P Terminal, LINE IN/OUT
△ 2	48484200	Plug, VOLTAGE SELECTOR (XX-V)
△ 3	15026209	Power Transformer (XX-V)
△	15026202	Power Transformer (UL, CSA)
△	15026205	Power Transformer (EU, BS)
△ 4	38004700	Power Supply Cord (XX-V)
△	38004500	Power Supply Cord (EU)
△	38004300	Power Supply Cord (UK)
△	46321000	Power Supply Cord (CSA)
△	48584600	Power Supply cord (UL)
5	47157300	AC Cord Cover
6	47679110	Side Panel Ass'y (R) (XX-V, CSA, EU, UK)
	27277500	Side Panel Ass'y (R) (UL)
7	47113110	Joint Shaft
8	48367900	Damper Ass'y
9	47608910	Side Panel Ass'y (L) (XX-V, CSA, EU, UK)
	27277400	Side Panel Ass'y (L) (UL)

8. WIRING DIAGRAM

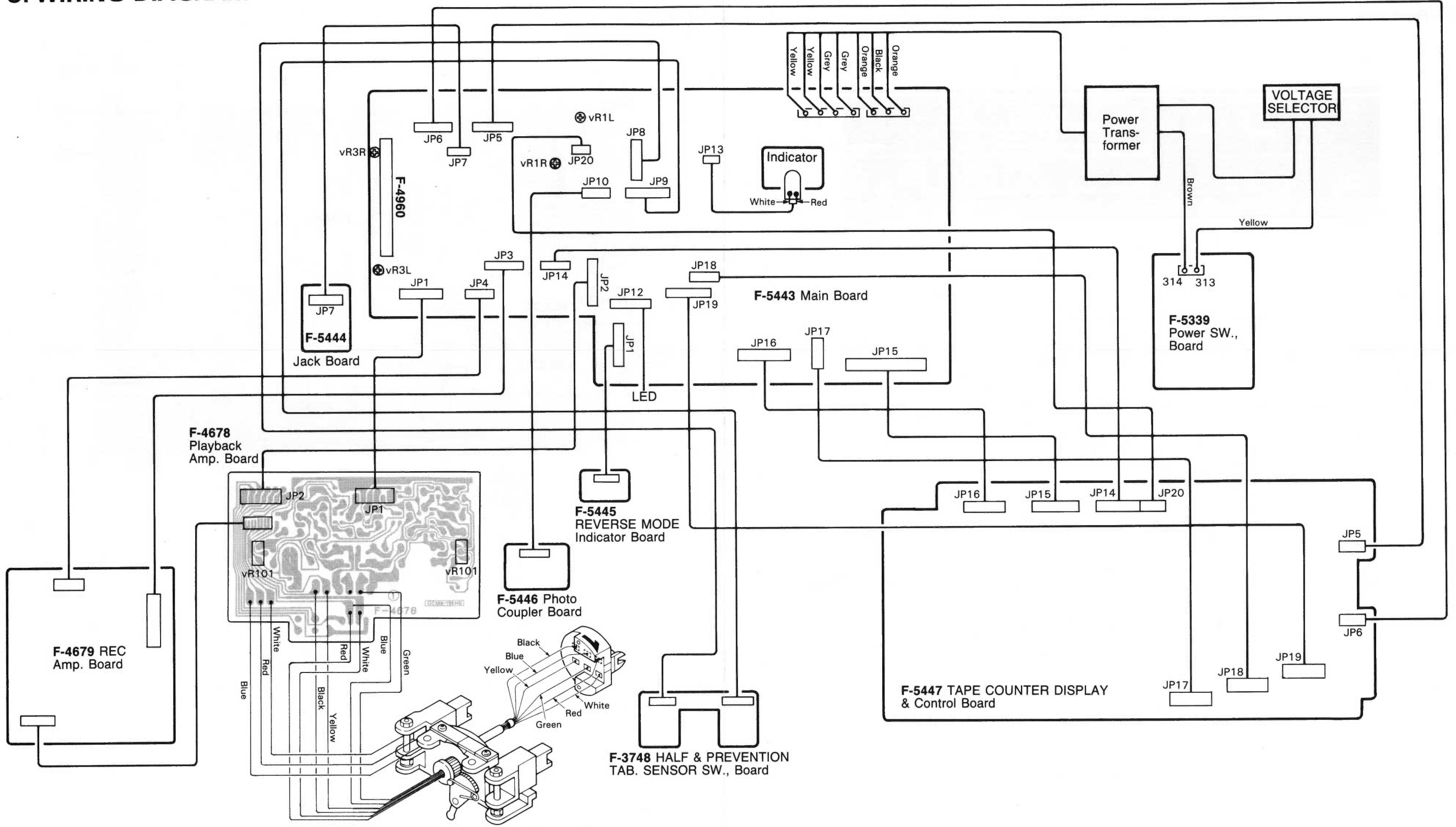

9. EXPLODED VIEW OF MECHANISM ASS'Y & PARTS LIST

9-1. Front View of Mechanism Chassis

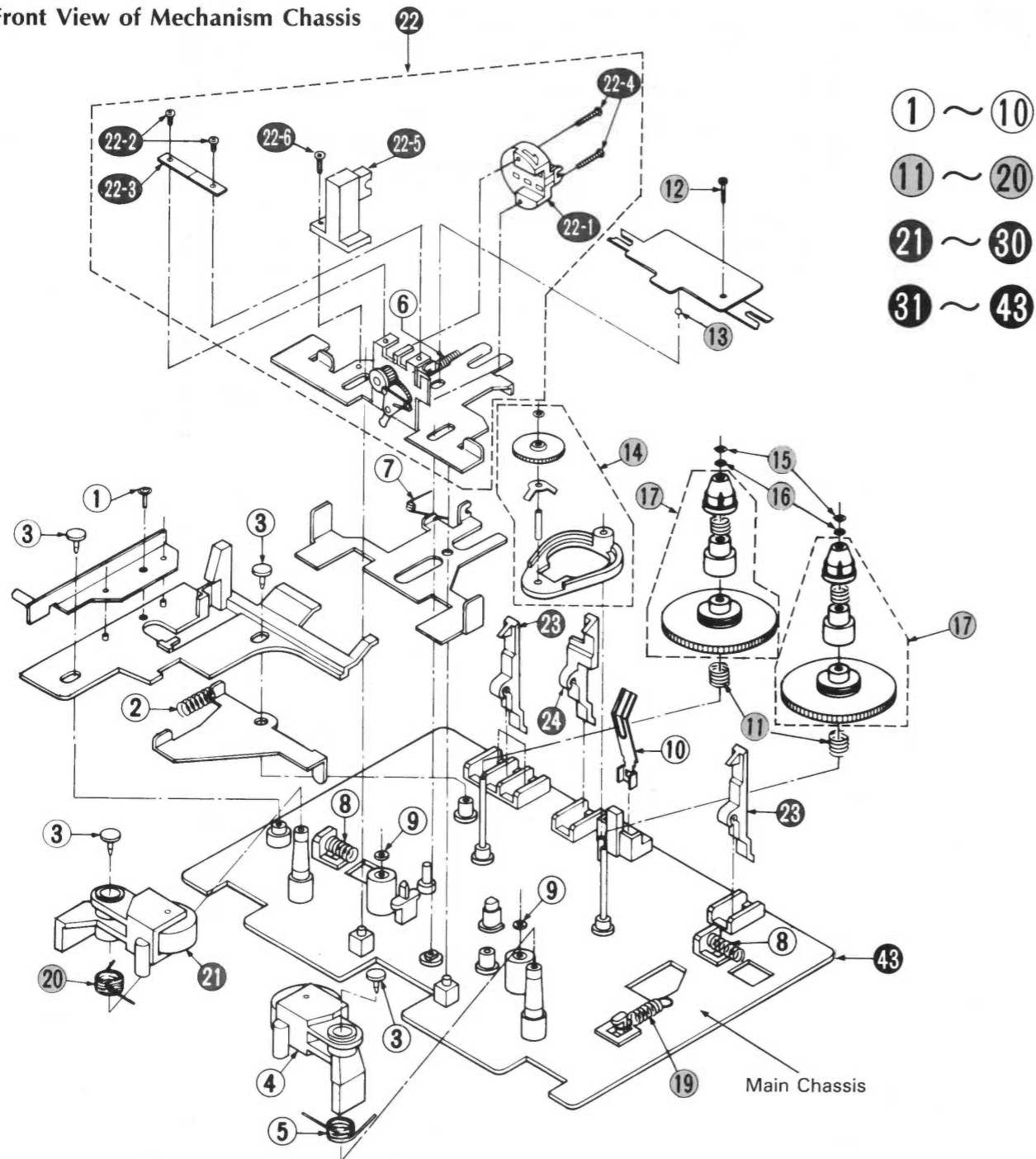

Parts List

Parts No.	Stock No.	Description	Parts No.	Stock No.	Description
1	46267800	Tapping Screw, M3.0x8	14	47405000	Arm Ass'y
2	47644500	Spring, eject	15	27083100	Washer, d = 1.6
3	47420900	Plastic Tack	16	47404600	Washer, d = 2.0
4	47281810	Pinch Roller (R) Ass'y	17	47835510	Reel Gear Ass'y
5	47405500	Spring, pinch roller (R) ass'y	18	46268100	Screw, M3x10
6	47406200	Spring, head base	19	47406300	Spring, push arm
7	47405600	Spring, slide base	20	47405400	Spring, pinch roller (L) ass'y
8	47668600	Spring, plunger solenoid	21	47281910	Pinch Roller (L) Ass'y
9	47404700	Nylon Washer, d = 2.5	22	16856601	REC/P.B Head Ass'y with sensor
10	47839410	Spring, half	22-1	48560900	REC/P.B Erase Head
11	47709620	Spring, reel	22-2	47835100	Screw, M2.0x5
12	18139300	Binding Head Screw, M2x12	22-3	47289200	Spring Plate, azimuth
13	47404900	Steel Ball, $\phi = 2.0$	22-4	46731300	Screw, M1.4x6

9-2. Rear View of Mechanism Chassis

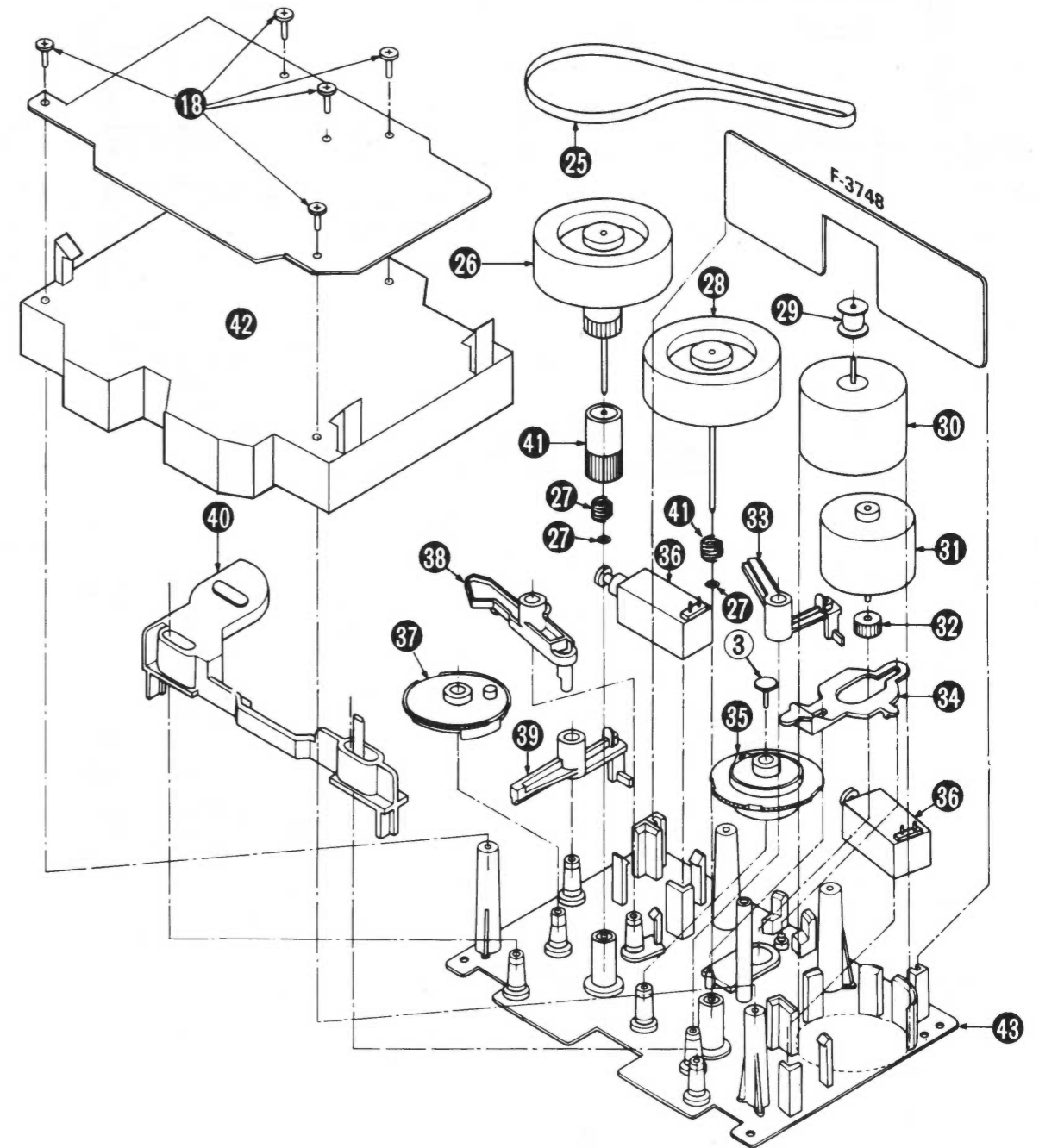

Parts No.	Stock No.	Description	Parts No.	Stock No.	Description
22-5	37031900	Photo Sensor Ass'y (with Photo Coupler, GP2L02)	32	47293110	Gear, reel motor
22-6	46398800	Screw, M2.0x6	33	47903310	Lock Arm (A)
23	47723020	Sensor Arm A2	34	47293810	Arm (B)
24	47292530	Sensor Arm B	35	47283840	Assist Gear (A)
25	47405200	Capstan Belt	36	47292610	Plunger Solenoid
26	47283010	Flywheel (R) Ass'y	37	47283910	Assist Gear (B)
27	47404600	Washer, d = 2.5	38	47283710	Push Arm
28	27218900	Flywheel (L) Ass'y	39	47281710	Lock Arm (B)
29	27285900	Pulley	40	47284200	FWD-REV Change Plate
30	46737400	Capstan Motor	41	47530000	Spring A, Flywheel
31	46737500	Reel Motor	42	47292830	Sub chassis
			43	47406580	Main Chassis

10 SCHEMATIC DIAGRAM

10-1. Audio Amp. Section

* Design and specifications subject to change without notice for improvement.
 * La présentation et les spécifications sont susceptibles d'être modifiées sans préavis par suites d'améliorations éventuelles.
 * Änderungen, die dem technischen Fortschritt dienen, bleiben vorbehalten.

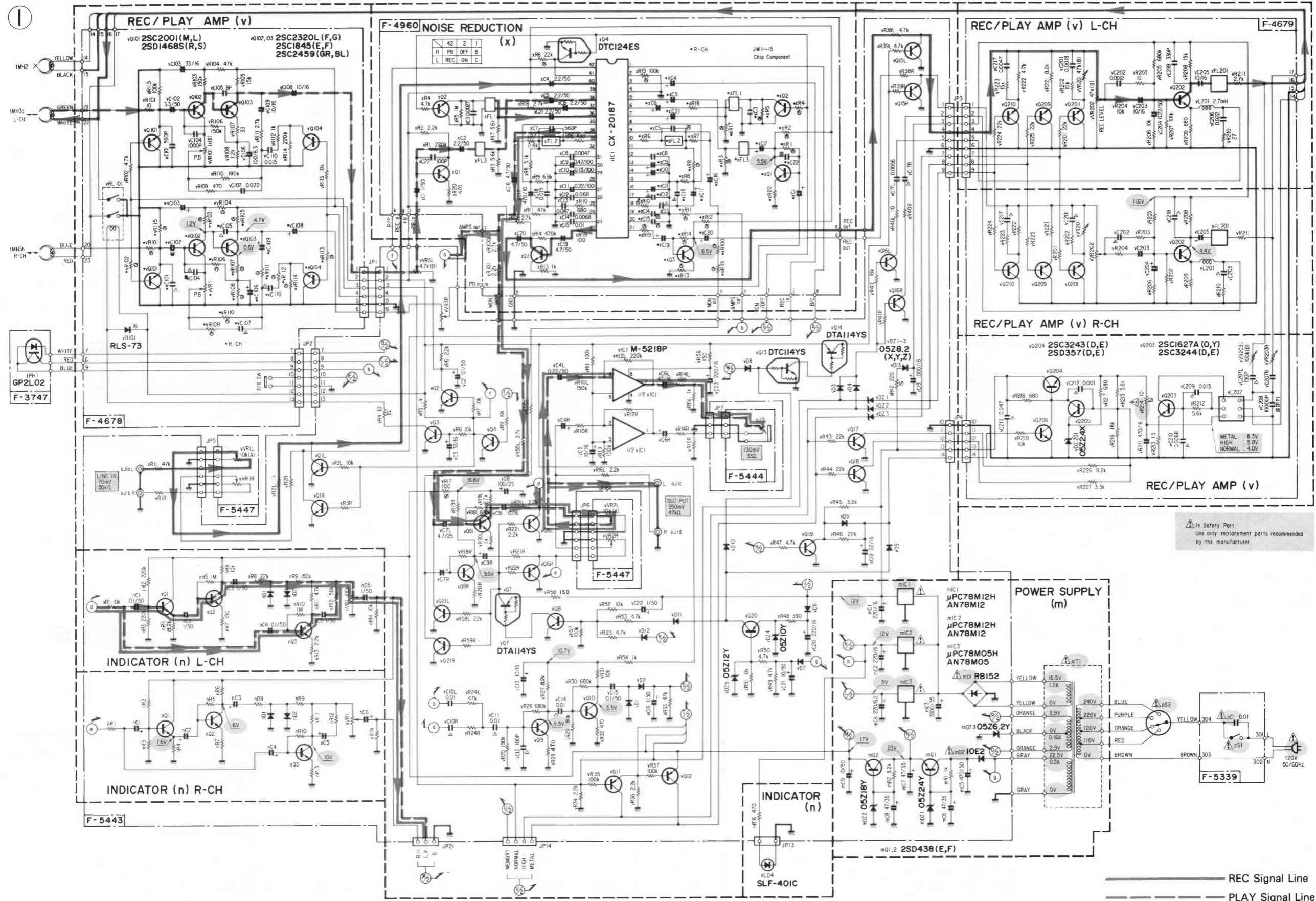

- 2SA952
- 2SC1627
- 2SC1845
- 2SC2001
- 2SC2320L
- 2SC2438
- 2SD438
- 2SC2785
- DTA114YS
- DTC114YS
- μPC78MC5H
- 2SA1115
- 2SA1175
- 2SC1740S
- 2SC2458
- 2SC2459
- 2SC2803
- DTC124ES
- μPD4069UBC
- BA6146
- BU4069UB
- CX20187
- LB1291
- LC4019B
- M5218P
- MB88501-H
- MSM4019RS
- Det or Slit or Line
- AN78M05
- AN78M12
- RLS-73
- AN78M12
- 1S1588
- 1S2473
- 10E-2
- 1:3PPT
- 2:8PPT
- 3:8D
- RB-152
- TLS-123
- TLG-123A
- TLY-123
- 05Z2.4
- 05Z3.0
- 05Z4.7
- 05Z6.2
- 05Z8.2
- 05Z10
- 05Z18
- 05Z24

⚠ is Safety Part
 Use only replacement parts recommended by the manufacturer.

— REC Signal Line
 — PLAY Signal Line

10-2. Logic Control Section

* Design and specifications subject to change without notice for improvement.
 * La présentation et les spécifications sont susceptibles d'être modifiées sans préavis par suites d'améliorations éventuelles.
 * Änderungen, die dem technischen Fortschritt dienen, bleiben vorbehalten.

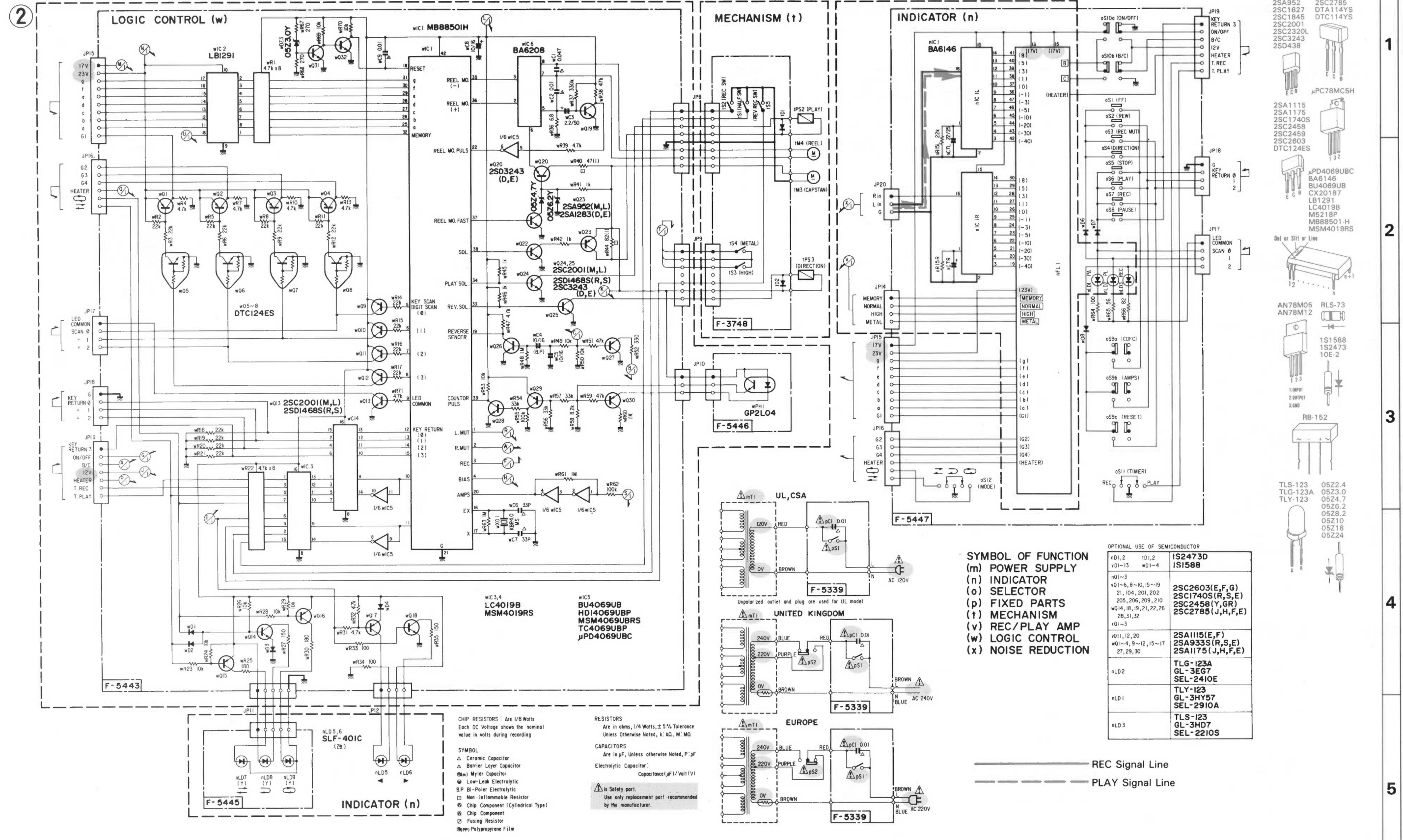

1

2

3

4

5

11. INTERIOR BLOCK DIAGRAM OF IC

•LB1291 (FL. Display Driver)

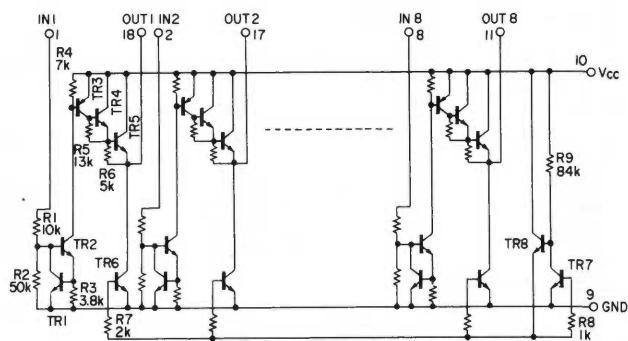

•CX20187 (Dolby Noise Reduction)

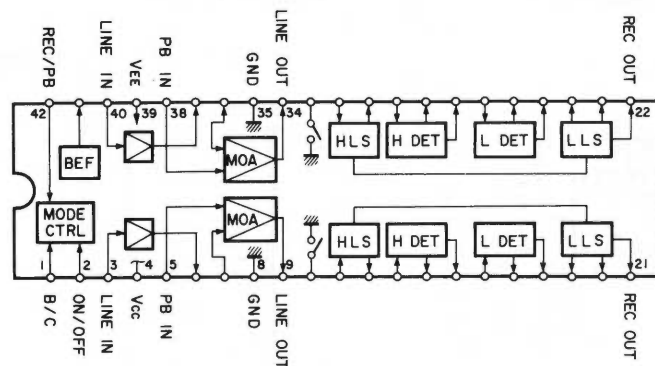

•LC4019B/MSM4019RS (Quad AND-OR Select Gate)

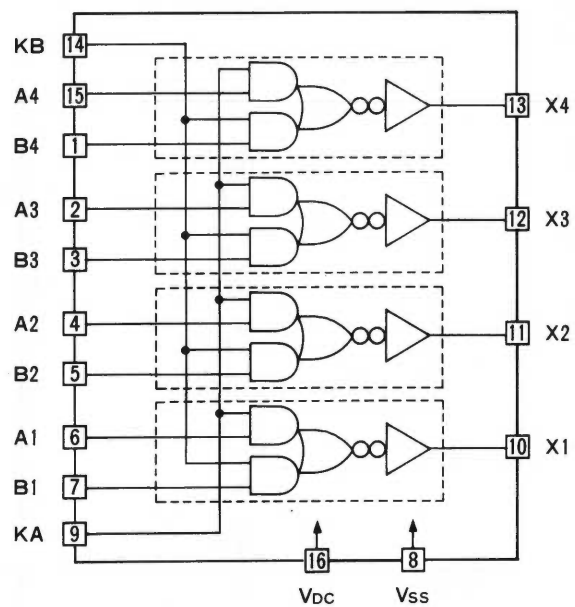

•Truth Table

An	Bn	KA	KB	Xn
0	0	1	0	0
1	0	1	0	1
0	1	1	0	0
1	1	1	0	1
0	0	0	1	0
1	0	0	1	0
0	1	0	1	1
1	1	0	1	1
0	0	1	1	0
1	0	1	1	1
0	1	1	1	1
1	1	1	1	1
*	*	0	0	0

1 : "Hi" * : don't care
0 : "Lo" n = 1 ~ 4

•M5218P (OP Amp.)

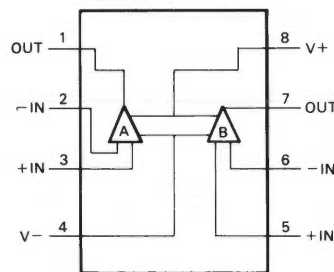

•BA6146 (Peak Level Meter)

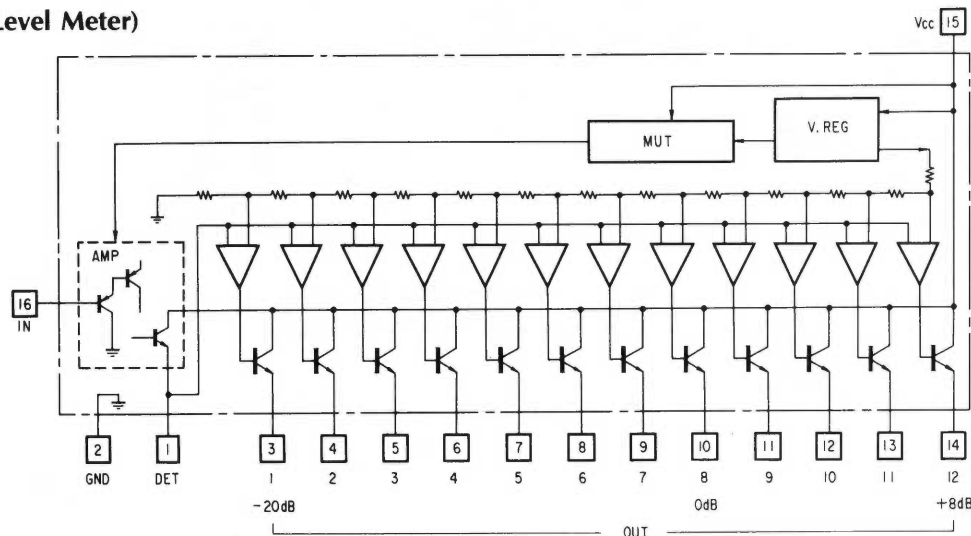

12. DESCRIPTION OF IC MB88501H

•Micro Computer MB88501H <Terminal Functions>

i/o	Pin No.	Function	ACTIVE	
			H	L
o	33	Reverse Solenoid (tPS3)	ON	
o	34	Play Solenoid (tPS2)	ON	
o	35	Reel Motor " + "	ON	
o	36	Reel Motor " - "	ON	
o	25	Indicator (nFL1)-a	Lighting	Putting out Light
o	26	Indicator (nFL1)-b	Lighting	Putting out Light
o	27	Indicator (nFL1)-c	Lighting	Putting out Light
o	28	Indicator (nFL1)-d	Lighting	Putting out Light
o	29	Indicator (nFL1)-e	Lighting	Putting out Light
o	30	Indicator (nFL1)-f	Lighting	Putting out Light
o	31	Indicator (nFL1)-g	Lighting	Putting out Light
o	32	Memory Indicator (nFL1)	Lighting	Putting out Light
i	37	Reel Motor	Normal	Fast
o	38	Play Solenoid (tPS2) Output	Start drive	
o	39	Counter Puls Input		
o	1	Line Muting Signal Output	ON	
o	2	REC Muting Signal Output	ON	
o	3	Line Input	Rec	
o	4	REC Mode Signal Output	Rec	
o	5	Key Scan/Digit Scan 0 Output		ON
o	6	Key Scan/Digit Scan 1 Output		ON
o	7	Key Scan/Digit Scan 2 Output		ON
o	8	Key Scan/Digit Scan 3 Output		ON
o	9	Rec/PL/PA Indicator Output	ON	
o	10	Input Select X		
o	11	Input Select Y		
i	12	Key Return 0 Input Half, SW/Timer Play		
i	13	Key Return 1 Input Rec, SW/Timer REL		
i	14	Key Return 2 Input Rec, SW/Rev. Mode		
i	15	Key Return 3 Input F/R SW/Rev. Mode		
i	19	Leader Sensor Input		
i	20	Amps Signal Input		
i	22	Mechanism Auto-Stop Signal Input Terminal from Reel Motor Drive Circuit		

13. PACKING LIST

Parts No.	Stock No.	Description
1	47859100	Vinyl Bag
2	27130100	Styrofoam Packing
3	27261900	Carton Case

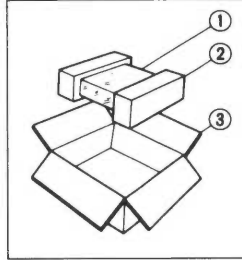

14. ACCESSORY LIST

Stock No.	Description
07193400	PJP Cord
or 38103300	PJP Cord
49013800	Operating Instruction (*E•F•S)
49013900	Operating Instruction (*G•I•Sw)

***Note:**

E•F•S: English•French and Spanish Version

G•I•Sw: German•Italian and Swedish Version

The Sansui logo is written in a stylized, italicized serif font. The letters are white and set against a solid black rectangular background.

SANSUI ELECTRIC CO., LTD.:

SANSUI ELECTRONICS CORPORATION:

SANSUI ELECTRONICS (U.K.) LTD.:
SANSUI ELECTRONICS G.M.B.H.:

14-1, Izumi 2-chome, Suginami-ku, Tokyo 168 Japan
PHONE: (03) 324-8891/TELEX: 232-2076 (International Division)
1250 Valley Brook Ave. Lyndhurst, N.J. 07071 U.S.A.
17150 South Margay Ave. Carson, California 90746 U.S.A.
3036 Koapaka Street, Honolulu, Hawaii 96819 U.S.A.

Unit 10A, Lyon Industrial Estate, Rockware Avenue, Greenford, Middx UB6. 0AA, England
Pau Ehrich Strasse 8, 6074 Rödermark 2, West Germany

(SM1-329)

(1986.9.M) <Stock No. 36526600>