

SERVICE MANUAL

STEREO DOUBLE CASSETTE DECK

SANSUI D-65BW



CAUTION

1. Parts identified by the Δ symbol on the schematic diagram and the parts list are critical for safety. Use only replacement parts that have critical characteristics recommended by the manufacturer.
2. Make leakage-current or resistance measurements to determine that exposed parts are acceptably insulated from the supply circuit before returning the appliance to the customer.

•SPECIFICATIONS

Track format.....	4-track/2-channel system
Tape speed.....	4.8 cm/sec.
Heads	
Rec/play head.....	HIGH-Bs hard permalloy
Erase head.....	Double-grap HIGH-Bs ferrite
Motor Electronically controlled DC motor x 2	
	Reels: DC Motor x 2
Wow/flutter.....	0.06% max (WRMS)
Fast forwarding (rewinding) time	
.....	Approx. 85 sec. (for C-60 tape)
Frequency response (-20 VU recording/playback)	
Normal tape (LH).....	20 to 15,000 Hz (30 to 14,000 Hz ± 3 dB)
Chrome Tape.....	20 to 16,000 Hz (30 to 15,000 Hz ± 3 dB)
Metal Tape.....	20 to 17,000 Hz (30 to 16,000 Hz ± 3 dB)
Erasure rate (metal tape)	
.....	70 dB min (1 kHz)
Recording bias frequency	
.....	85 kHz
Input sensitivity/impedance	
LINE IN (REC).....	150 mV/47 kohms
Signal to noise ratio (Record/Playback)	
Metal Tape (without Dolby Noise Reduction) better than 54 dB
(With Dolby Noise Reduction Effect) better than 64 dB
DOLBY "B" NR..... better than 64 dB (above 5 kHz)
Power requirements	
Power voltage.....	120/220/240V (50/60 Hz)
For U.S.A. and Canada 120V (60 Hz)
Power consumption.....	20 watts
Dimensions	
	430 mm (16-15/16") W
	112 mm (4-7/16") H
	221 mm (8-3/4") D
Weight.....	3.9 kg (8.6 lbs.) net
* Design and specifications subject to changes without notice for improvements.	
* Noise reduction system manufactured under license from Dolby Laboratories Licensing Corporation. "Dolby" and the double D symbol are trade marks of Dolby Laboratories Licensing Corporation.	



SANSUI ELECTRIC CO., LTD.

CAUTION

1. The symbols, UL, CSA, SA, BS, UK, EU, AS and XX (EXPORT) on the parts list and the schematic diagram mean followings respectively.
 - UL..... Manufactured for U.S.A market.
(Underwriters Laboratories approved model.)
 - CSA Manufactured for Canadian market.
 - SA..... Manufactured for South African market.
 - BS, UK Manufactured for United Kingdom market.
 - EU Manufactured for European market.
 - AS..... Manufactured for Australian market.
 - XX (EXPORT) Standard Version.
 - NON MARK Common Parts.

2. Some printed circuit boards are not supplied as the assembled. To separate these in this service manual, the stock No's are not indicated at the ends of the board names. However, the individual parts on the circuit boards are provided by orders.

3. Since some of capacitors and resistors are omitted from parts lists in this service manual, refer to the Common Parts List for capacitors & resistors, which was issued on February 1983.

4. Abbreviations in this service manual are as follows.

•Abbreviations List

C.R. : Carbon Resistor	E.B.L. : Low Leak Bi-Polar Electrolytic Capacitor
S.R. : Solid Resistor	Ta.C. : Tantalum Capacitor
Ce.R. : Cement Resistor	F.C. : Film Capacitor
M.R. : Metal Film Resistor	M.P. : Metalized Paper Capacitor
F.R. : Fusing Resistor	P.C. : Polystyrene Capacitor
N.I.R. : Non-Inflammable Resistor	G.C. : Gimmic Capacitor
A.R. : Array Resistor	A.C. : Array Capacitor
C.C. : Ceramic Capacitor	V.R. : Variable Resistor
C.T. : Ceramic Capacitor, Temperature Compensation	S.V.R. : Semi Variable Resistor
E.C. : Electrolytic Capacitor	SW. : Switch
E.L. : Low Leak Electrolytic Capacitor	Chip R. : Chip Resistor
E.B. : Bi-Polar Electrolytic Capacitor	Chip C. : Chip Capacitor

1. BLOCK DIAGRAM

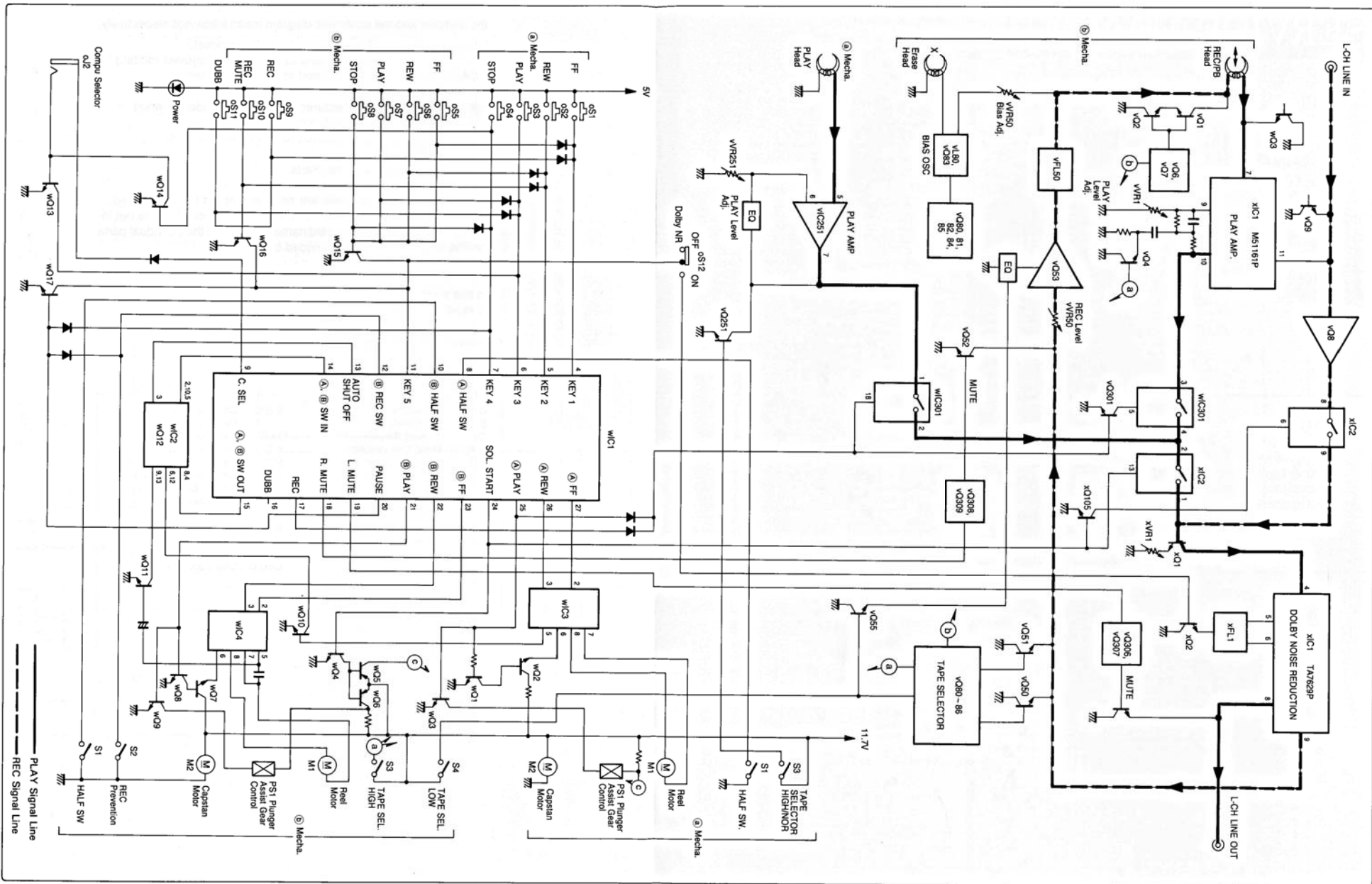

2. OPERATIONS OF PINCH ROLLER

2-1. Torque Transportation Flowchart

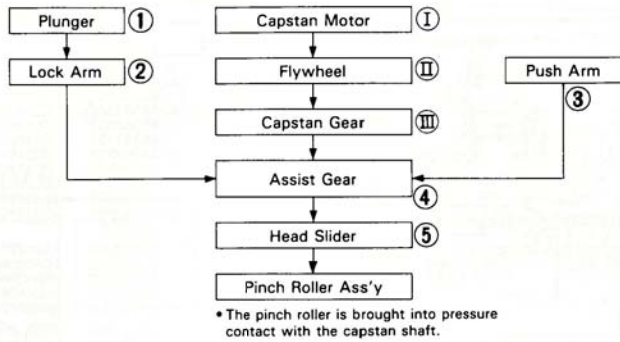

2-2. Rear View of Mechanism Chassis

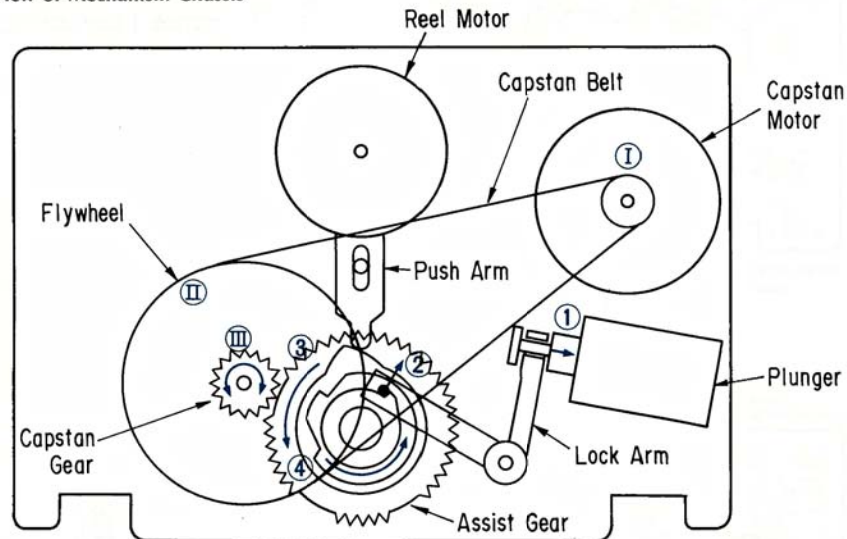

2-3. Front View of Mechanism Chassis

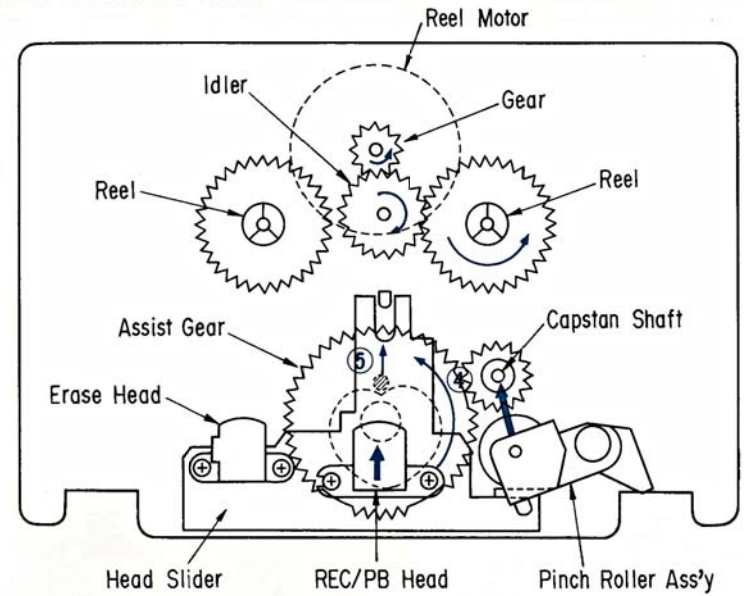

2-4. Cam Positions in the Modes of PLAY, FF, REW & STOP

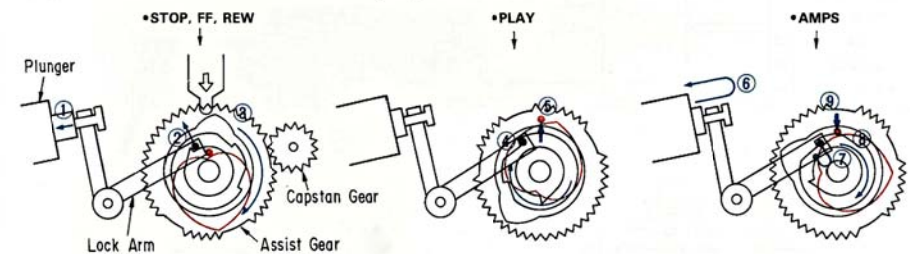

3. TIMING CHART OF CONTROL IC, TC9312N-025

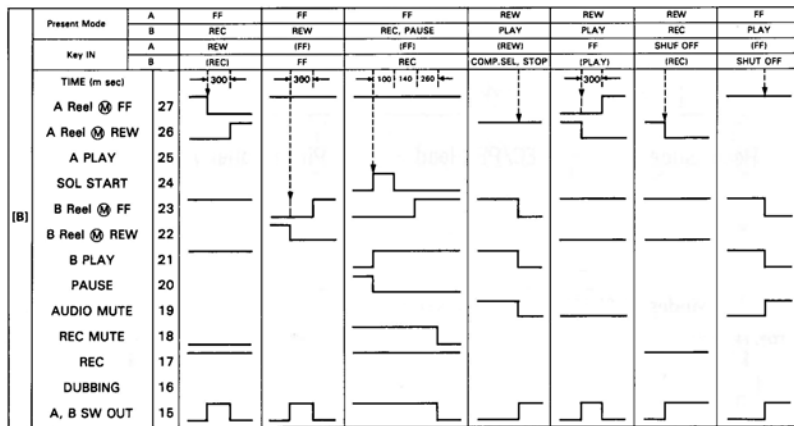
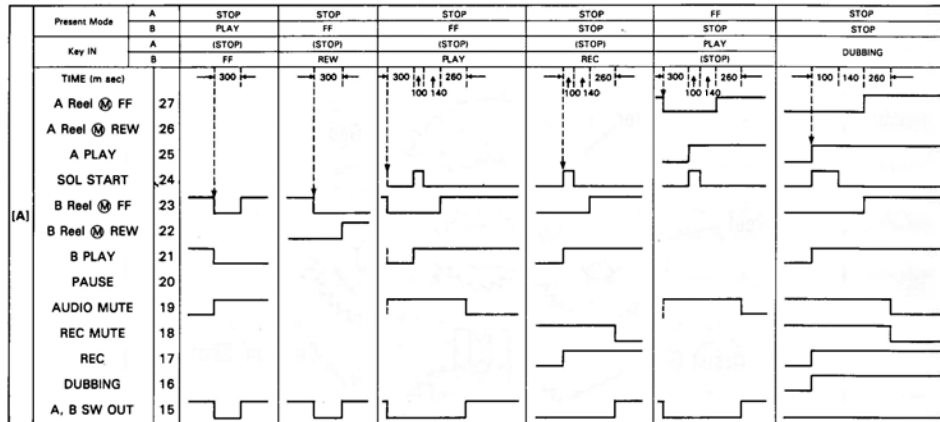

Pin Connection of TC9312N-025

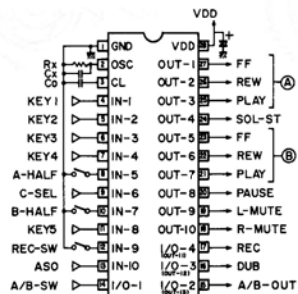

Input Relation of Control IC, TC9312-025

IC INPUT	KEY 1	KEY 2	KEY 3	KEY 4	KEY 5
TACT SW INPUT					
ⒶFF	○	○	○	○	○
ⒶREW	○	○	○	○	○
ⒶPLAY	○	○	○	○	○
ⒶSTOP	○	○	○	○	○
ⒷFF	○	○	○	○	○
ⒷREW	○	○	○	○	○
ⒷPLAY	○	○	○	○	○
ⒷSTOP	○	○	○	○	○
ⒷREC	○	○	○	○	○
ⒷREC MUTE	○	○	○	○	○
DUBBING	○	○	○	○	○

4. PARTS LOCATION & PARTS LIST

4-1. F-4959 Noise Reduction Board (Stock No. 00886401) Component Side

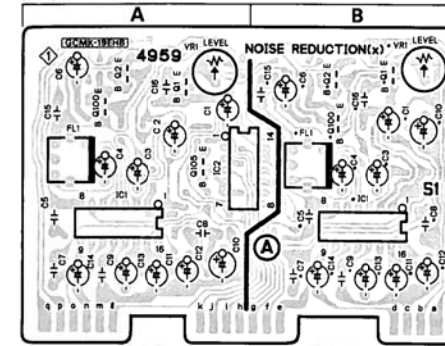

Pattern Side <Chip Parts>

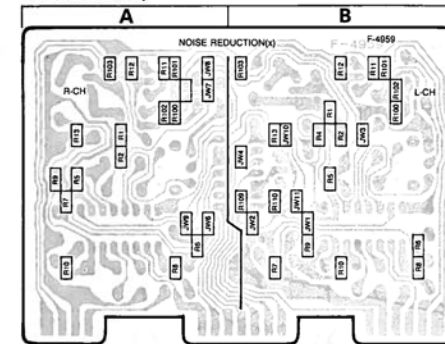

*Note: On this circuit board, the right channel is specified by "●" mark on top of the parts No.

Parts List

Parts No.	Stock No.	Description
• Transistor		
xQ1	46367101	2SC2603
	or 46367301	2SC2458
	or 48058801	2SC1740S
xQ2	46367101	2SC2603
	or 46367301	2SC2458
	or 48058801	2SC1740S
xQ100	46367101	2SC2603
	or 46367301	2SC2458
	or 48058801	2SC1740S
xQ105	46367101	2SC2603
	or 46367301	2SC2458
	or 48058801	2SC1740S
• IC		
xiC1	46128200	TA7629P
xiC2	07224800	TC4066BP
	or 46421000	μPD4066BC
	or 48054500	MSM4066BRS
	or 48063800	BU4066B
xJW1	46741100	Cross Conductor (Chip)
xJW2	46741100	Cross Conductor (Chip)
xJW3	46741100	Cross Conductor (Chip)
xJW4	46741100	Cross Conductor (Chip)
xJW6	46741100	Cross Conductor (Chip)
xJW7	46741100	Cross Conductor (Chip)
xJW8	46741100	Cross Conductor (Chip)
xJW9	46741100	Cross Conductor (Chip)
xJW10	46741100	Cross Conductor (Chip)
xJW11	46741100	Cross Conductor (Chip)
xR1	46753200	220kΩ 1/8W Chip R.
xR2	46748200	1.8kΩ 1/8W Chip R.
xR4	46747200	680Ω 1/8W Chip R.
xR5	46752400	100kΩ 1/8W Chip R.
xR6	46745800	180Ω 1/8W Chip R.
xR7	46748800	3.3kΩ 1/8W Chip R.
xR8	46751600	47kΩ 1/8W Chip R.
xR9	46752800	150kΩ 1/8W Chip R.
xR10	46753400	270kΩ 1/8W Chip R.
xR11	46750000	10kΩ 1/8W Chip R.
xR12	46754800	1MΩ 1/8W Chip R.
xR13	46751600	47kΩ 1/8W Chip R.
xR100	46748600	2.7kΩ 1/8W Chip R.
xR101	46748400	2.2kΩ 1/8W Chip R.
xR102	46749100	4.3kΩ 1/8W Chip R.
xR103	46748400	2.2kΩ 1/8W Chip R.
xR109	46750000	10kΩ 1/8W Chip R.
xR110	46751600	47kΩ 1/8W Chip R.
xFL1	46177500	DOLBY Filter
	or 46177501	DOLBY Filter
xVR1	46633700	1kΩ (B) S.V.R., PLAY Level
	or 48199300	1kΩ (B) S.V.R., PLAY Level

4-2. F-5232 PLAY Amp. Board (Stock No. 00953201) Component Side

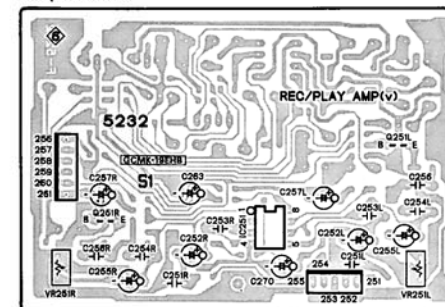

Pattern Side <Chip Parts>

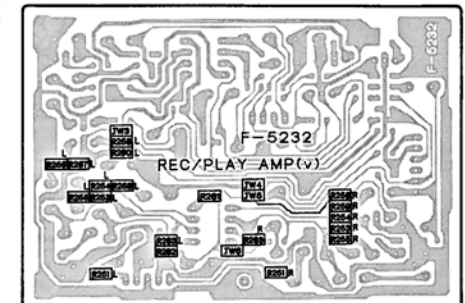

4-3. F-5195 Input Key Board

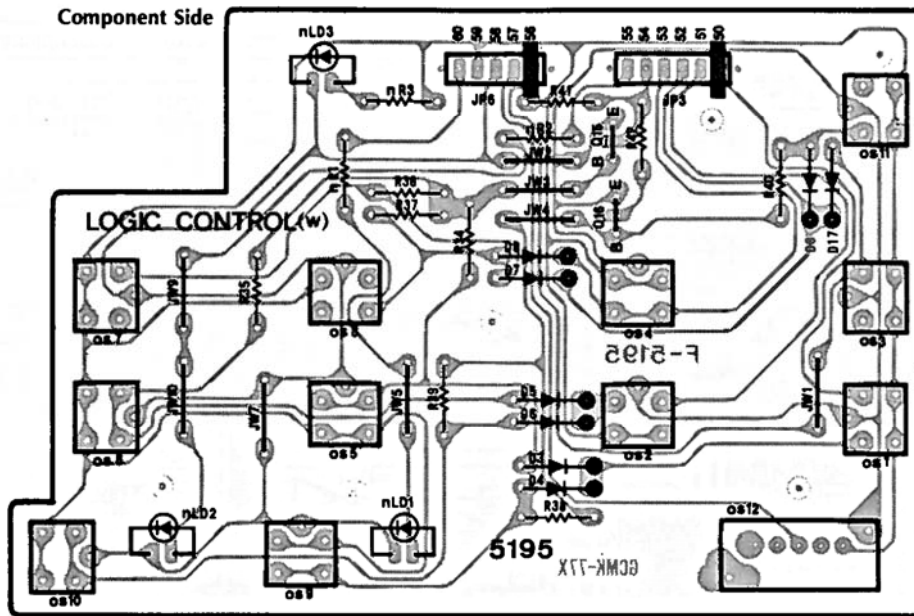

Parts List

Parts No.	Stock No.	Description
•LED		
nLD1	46176900 or 46470200 or 48189000	TLS-123, REC SEL2210S, REC GL-3HD7, REC
nLD2	07251000 or 46470400 or 48189100	TLY-123, PAUSE SEL2910A, PAUSE GL3HY57, PAUSE
nLD3	46176900 or 46470200 or 48189000	TLS-123, POWER SEL2210S, POWER GL-3HD7, POWER
oS1	48113200	Push SW., A FF
oS2	48113200	Push SW., A REW
oS3	48113200	Push SW., A PLAY
oS4	48113200	Push SW., A STOP
oS5	48113200	Push SW., B FF
oS6	48113200	Push SW., B REW
oS7	48113200	Push SW., B PLAY
oS8	48113200	Push SW., B STOP
oS9	48113200	Push SW., REC
oS10	48113200	Push SW., REC MUTE
oS11	48113200	Push SW., DUBBING
oS12	48158200	Slide SW., DOLBY NR

Parts No.	Stock No.	Description
•Transistor		
wQ15	46367101 or 46391901 or 48058801	2SC2603 2SC2785 2SC1740S
wQ16	46367101 or 46391901 or 48058801	2SC2603 2SC2785 2SC1740S
•Diode		
wD3	03117600 or 46086000	1S2473T77 1S1588TP-3
wD4	03117600 or 46086000	1S2473T77 1S1588TP-3
wD5	03117600 or 46086000	1S2473T77 1S1588TP-3
wD6	03117600 or 46086000	1S2473T77 1S1588TP-3
wD7	03117600 or 46086000	1S2473T77 1S1588TP-3
wD8	03117600 or 46086000	1S2473T77 1S1588TP-3
wD9	03117600 or 46086000	1S2473T77 1S1588TP-3
wD17	03117600 or 46086000	1S2473T77 1S1588TP-3

Parts List <F-5232>

Parts No.	Stock No.	Description
•Transistor		
vQ251	46367101 or 46391901 or 48058801	2SC2603 2SC2785 2SC1740S
•IC		
vIC251	46638700	M5220P
vJW3	46741100	Cross Conductor (Chip)
vJW4	46741100	Cross Conductor (Chip)
vJW5	46741100	Cross Conductor (Chip)
vJW6	46741100	Cross Conductor (Chip)
vJW15	46741100	Cross Conductor (Chip)
vJW16	46741100	Cross Conductor (Chip)
vJW17	46741100	Cross Conductor (Chip)

Parts No.	Stock No.	Description
vR251	46742800	10Ω 1/8W Chip R.
vR253	46752600	120kΩ 1/8W Chip R.
vR254	46748400	2.2kΩ 1/8W Chip R.
vR255	46746600	390Ω 1/8W Chip R.
vR256	46746200	270Ω 1/8W Chip R.
vR257	46753200	220kΩ 1/8W Chip R.
vR258	46750000	10kΩ 1/8W Chip R.
vR259	46747600	1kΩ 1/8W Chip R.
vR260	46752400	100kΩ 1/8W Chip R.
vR281	46751600	47kΩ 1/8W Chip R.
vR282	46751600	47kΩ 1/8W Chip R.
vR283	46753200	220kΩ 1/8W Chip R.
vVR251	48078600	1kΩ S.V.R., PLAY Level

4-4. F-5193 Power Supply Board (Stock No. 00952801)
Component Side

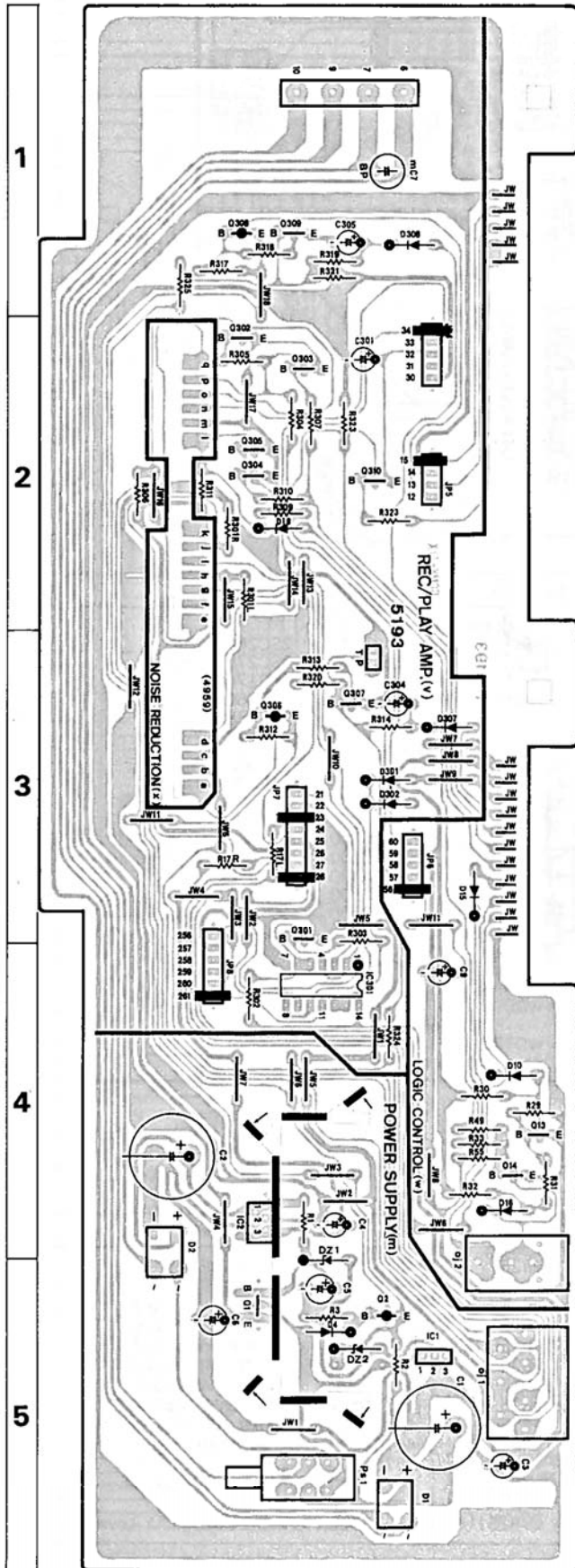

Parts List

Parts No.	Stock No.	Description
• Transistor		
Δ mQ1	48150101	2SD1406
mQ2	46719800	DTA124ES
• IC		
Δ mIC1	46144200	NJM78M05A
Δ	or 46359400	L78N05
Δ mIC2	46499800	L78N09
• Diode		
Δ mD1	46273600	DBB10-B
Δ mD2	46273600	DBB10-B
mD3	03117600	1S2473T77
or	46086000	1S1588TP-3
mD4	03117600	1S2473T77
or	46086000	1S1588TP-3
• Zener Diode		
mDZ1	46113800	05Z12-X
or	46113900	05Z12-Y
mDZ2	46112600	05Z8.2-X
or	46112700	05Z8.2-Y
mC7	48103700	4.7μF 50V E.B.
oJ2	46547200	Jack, COMPU SELECTOR
oJ1	46371500	4P Terminal, LINE IN/OUT
Δ pS1	48172700	Push SW., POWER
• Transistor		
vQ301	46367101	2SC2603
or	46391901	2SC2785
or	48058801	2SC1740S
vQ302	46367101	2SC2603
or	46391901	2SC2785
or	48058801	2SC1740S
vQ303	46367101	2SC2603
or	46391901	2SC2785
or	48058801	2SC1740S
vQ304	46367101	2SC2603
or	46391901	2SC2785
or	48058801	2SC1740S
vQ305	46367101	2SC2603
or	46391901	2SC2785
or	48058801	2SC1740S
vQ306	46367001	2SA1115
or	46392001	2SA1175
vQ307	46367101	2SC2603
or	46391901	2SC2785
or	48058801	2SC1740S
vQ308	46367001	2SA1115
or	46392001	2SA1175
vQ309	46367101	2SC2603
or	46391901	2SC2785
or	48058801	2SC1740S
vQ310	46367101	2SC2603
or	46391901	2SC2785
or	48058801	2SC1740S
• IC		
vIC301	46421000	μPD4066BC
or	48054500	MSM4066BRS
or	48063800	BU4066B
• Diode		
vD301	03117600	1S2473T77
or	46086000	1S1588TP-3
vD302	03117600	1S2473T77
or	46086000	1S1588TP-3
vD303	03117600	1S2473T77
or	46086000	1S1588TP-3
vD304	03117600	1S2473T77
or	46086000	1S1588TP-3
vD305	03117600	1S2473T77
or	46086000	1S1588TP-3
vD306	03117600	1S2473T77
or	46086000	1S1588TP-3
vD307	03117600	1S2473T77
or	46086000	1S1588TP-3
vD308	03117600	1S2473T77
or	46086000	1S1588TP-3

Parts List <F-5193>

Parts No.	Stock No.	Description
•Transistor		
wQ13	46367101	2SC2603
	or 46391901	2SC2785
	or 48058801	2SC1740S
wQ14	46367101	2SC2603
	or 46391901	2SC2785
	or 48058801	2SC1740S

Parts No.	Stock No.	Description
•Diode		
wD10	03117600	1S2473T77
	or 46086000	1S1588TP-3
wD15	03117600	1S2473T77
	or 46086000	1S1588TP-3
wD16	03117600	1S2473T77
	or 46086000	1S1588TP-3
wD18	03117600	1S2473T77
	or 46086000	1S1588TP-3

4-5. F-5194 Logic Control Board (Stock No. 00952901)
Component Side

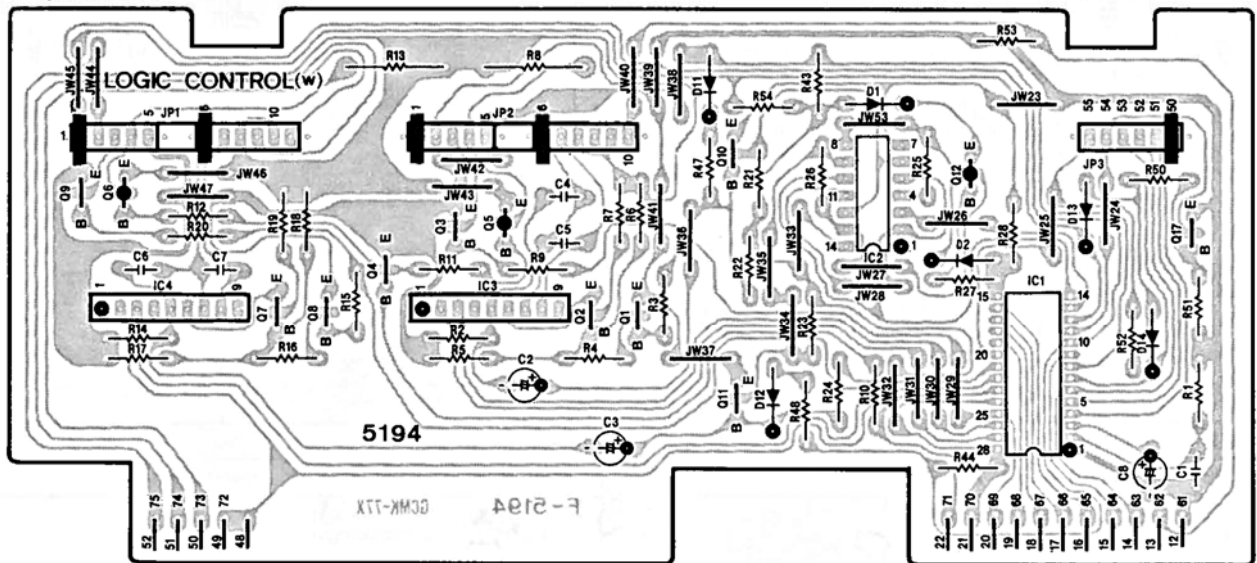

Parts List

Parts No.	Stock No.	Description
•Transistor		
wQ1	46367101	2SC2603
	or 46391901	2SC2785
	or 48058801	2SC1740S
wQ2	46614101	2SC3243
wQ3	46359801	2SC2001
	or 46614101	2SC3243
	or 48055901	2SD1468S
wQ4	46367101	2SC2603
	or 46391901	2SC2785
	or 48058801	2SC1740S
wQ5	46359701	2SA952
	or 46614001	2SA1283
wQ6	46359701	2SA952
	or 46614001	2SA1283
wQ7	46614101	2SC3243
wQ8	46367101	2SC2603
	or 46391901	2SC2785
	or 48058801	2SC1740S
wQ9	46359801	2SC2001
wQ10	46367101	2SC2603
	or 46391901	2SC2785
	or 48058801	2SC1740S
wQ11	46367101	2SC2603
	or 46391901	2SC2785
	or 48058801	2SC1740S
wQ12	46367001	2SA1115
	or 46392001	2SA1175
	or 48058601	2SA933S
wQ17	46367101	2SC2603
	or 46391901	2SC2785
	or 48058801	2SC1740S

Parts No.	Stock No.	Description
•IC		
wIC1	48313600	TC9312N-025
wIC2	46443800	μPD4001BC
	or 48050000	MSM4001BRS
	or 48067200	BU4001B
wIC3	46149600	BA6208
wIC4	46149600	BA6208
•Diode		
wD1	03117600	1S2473T77
	or 46086000	1S1588TP-3
wD2	03117600	1S2473T77
	or 46086000	1S1588TP-3
wD11	03117600	1S2473T77
	or 46086000	1S1588TP-3
wD12	03117600	1S2473T77
	or 46086000	1S1588TP-3
wD13	03117600	1S2473T77
	or 46086000	1S1588TP-3
wD14	03117600	1S2473T77
	or 46086000	1S1588TP-3
ΔwR7	00133500	27Ω 1/2W N.I.R.
ΔwR8	46624200	82Ω 2W N.I.R.
ΔwR13	46624200	82Ω 2W N.I.R.
ΔwR19	00133500	27Ω 1/2W N.I.R.
wC1	46695200	0.01μF 50V F.C.
wC5	46284100	0.1μF 50V F.C.
wC7	46284100	0.1μF 50V F.C.

4-6. F-5299 REC/PLAY Amp. Board (Stock No. 00953101)
Component Side

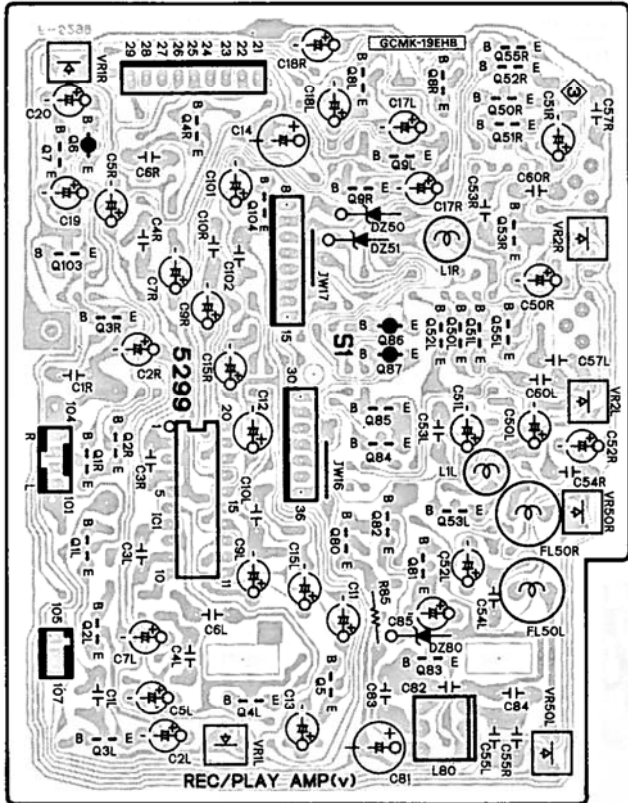

Pattern Side <Chip Parts>

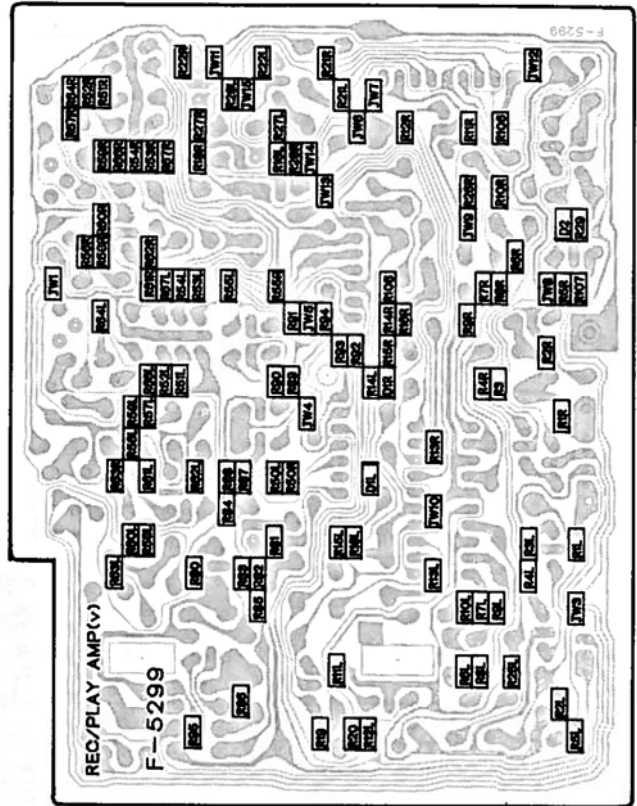

Parts List

Parts No.	Stock No.	Description
• Transistor		
vQ1	46581701	2SC1845
vQ2	46581701	2SC1845
vQ3	46359801	2SC2001
	or 48055901	2SD1468S
vQ4	46367101	2SC2603
	or 46367301	2SC2458
	or 48058801	2SC1740S
vQ5	46367101	2SC2603
	or 46367301	2SC2458
	or 48058801	2SC1740S
vQ6	46719800	DTA124ES
vQ7	46719900	DTC124ES
vQ8	46367101	2SC2603
	or 46367301	2SC2458
	or 48058801	2SC1740S
vQ9	46367101	2SC2603
	or 46367301	2SC2458
	or 48058801	2SC1740S
vQ50	46367101	2SC2603
	or 46367301	2SC2458
	or 48058801	2SC1740S
vQ51	46367101	2SC2603
	or 46367301	2SC2458
	or 48058801	2SC1740S
vQ52	46367101	2SC2603
	or 46367301	2SC2458
	or 48058801	2SC1740S
vQ53	46367101	2SC2603
	or 46367301	2SC2458
	or 48058801	2SC1740S
vQ55	46367101	2SC2603
	or 46367301	2SC2458
	or 48058801	2SC1740S
vQ80	46614101	2SC3243
vQ81	46367101	2SC2603
	or 46367301	2SC2458
	or 48058801	2SC1740S

Parts No.	Stock No.	Description
vQ82	46367101	2SC2603
	or 46367301	2SC2458
	or 48058801	2SC1740S
vQ83	48061801	2SC3244
vQ84	46367101	2SC2603
	or 46367301	2SC2458
	or 48058801	2SC1740S
vQ85	46367101	2SC2603
	or 46367301	2SC2458
	or 48058801	2SC1740S
vQ86	46367001	2SA1115
	or 46392001	2SA1175
	or 48058601	2SA933S
vQ87	46367001	2SA1115
	or 46392001	2SA1175
	or 48058601	2SA933S
vQ103	46367101	2SC2603
	or 46367301	2SC2458
	or 48058801	2SC1740S
• IC		
vIC1	46362100	M51161P
• Diode		
vD1	46852000	RLS-73 (Chip)
vD2	46852000	RLS-73 (Chip)
• Zener Diode		
vDZ50	46111100	05Z5.1-X
	or 46111200	05Z5.1-Y
	or 46111300	05Z5.1-Z
vDZ51	46111100	05Z5.1-X
	or 46111200	05Z5.1-Y
	or 46111300	05Z5.1-Z
vDZ80	46109000	05Z2.7-X
vJW1	46741100	Cross Conductor (Chip)
vJW3	46741100	Cross Conductor (Chip)

Parts List < F-5299 >

Parts No.	Stock No.	Description
vJW4	46741100	Cross Conductor (Chip)
vJW5	46741100	Cross Conductor (Chip)
vJW6	46741100	Cross Conductor (Chip)
vJW7	46741100	Cross Conductor (Chip)
vJW8	46741100	Cross Conductor (Chip)
vJW9	46741100	Cross Conductor (Chip)
vJW10	46741100	Cross Conductor (Chip)
vJW11	46741100	Cross Conductor (Chip)
vJW12	46741100	Cross Conductor (Chip)
vJW13	46741100	Cross Conductor (Chip)
vJW14	46741100	Cross Conductor (Chip)
vJW15	46741100	Cross Conductor (Chip)
vR1	46742800	10Ω 1/8W Chip R.
vR2	46753200	220kΩ 1/8W Chip R.
vR3	46750400	15kΩ 1/8W Chip R.
vR4	46748800	3.3kΩ 1/8W Chip R.
vR5	46748400	2.2kΩ 1/8W Chip R.
vR6	46746600	390Ω 1/8W Chip R.
vR7	46748400	2.2kΩ 1/8W Chip R.
vR8	46752600	120kΩ 1/8W Chip R.
vR9	46748000	1.5kΩ 1/8W Chip R.
vR10	46746200	270Ω 1/8W Chip R.
vR11	46753200	220kΩ 1/8W Chip R.
vR12	46750800	22kΩ 1/8W Chip R.
vR13	46744900	75Ω 1/8W Chip R.
vR14	46748400	2.2kΩ 1/8W Chip R.
vR15	46747400	820Ω 1/8W Chip R.
vR16	46746200	270Ω 1/8W Chip R.
vR18	46748000	1.5kΩ 1/8W Chip R.
vR19	46750800	22kΩ 1/8W Chip R.
vR20	46748400	2.2kΩ 1/8W Chip R.
vR21	46749200	4.7kΩ 1/8W Chip R.
vR22	46753200	220kΩ 1/8W Chip R.
vR26	46747600	1kΩ 1/8W Chip R.
vR27	46749200	4.7kΩ 1/8W Chip R.
vR28	46750000	10kΩ 1/8W Chip R.
vR29	46750800	22kΩ 1/8W Chip R.
vR50	46749200	4.7kΩ 1/8W Chip R.
vR51	46749800	8.2kΩ 1/8W Chip R.
vR52	46751000	27kΩ 1/8W Chip R.
vR53	46750000	10kΩ 1/8W Chip R.
vR54	46750000	10kΩ 1/8W Chip R.
vR55	46749200	4.7kΩ 1/8W Chip R.
vR56	46750000	10kΩ 1/8W Chip R.
vR57	46749800	8.2kΩ 1/8W Chip R.
vR58	46754400	680kΩ 1/8W Chip R.
vR59	46753400	270kΩ 1/8W Chip R.
vR60	46750400	15kΩ 1/8W Chip R.
vR61	46747600	1kΩ 1/8W Chip R.
vR62	46742800	10Ω 1/8W Chip R.
vR63	46748400	2.2kΩ 1/8W Chip R.
vR64	46750400	15kΩ 1/8W Chip R.
vR66	46742800	10Ω 1/8W Chip R.
vR67	46750000	10kΩ 1/8W Chip R.
vR80	46750000	10kΩ 1/8W Chip R.
vR81	46747200	680Ω 1/8W Chip R.
vR82	46747200	680Ω 1/8W Chip R.
vR83	46749200	4.7kΩ 1/8W Chip R.
vR84	46751600	47kΩ 1/8W Chip R.
vR85	46681300	10Ω 1/4W F.R.
vR86	46750000	10kΩ 1/8W Chip R.
vR87	46750000	10kΩ 1/8W Chip R.
vR88	46748800	3.3kΩ 1/8W Chip R.
vR89	46750800	22kΩ 1/8W Chip R.
vR90	46750800	22kΩ 1/8W Chip R.
vR91	46752400	100kΩ 1/8W Chip R.
vR92	46748400	2.2kΩ 1/8W Chip R.
vR93	46748400	2.2kΩ 1/8W Chip R.
vR94	46752400	100kΩ 1/8W Chip R.
vR95	46742000	4.7Ω 1/8W Chip R.
vR106	46747200	680Ω 1/8W Chip R.
vR107	46750800	22kΩ 1/8W Chip R.

Parts No.	Stock No.	Description
vC53	46695800	0.018μF 50V F.C.
vC60	46694800	6800pF 50V F.C.
vC81	46929100	100μF 16V E.C.
vC84	46657000	3900pF 100V F.C.
vFL50	42904400	Peaking Coil
vL1	48121500	Inductor 2.7mH
vL80	48354900	FM RF Coil
vVR1	48078400	470Ω S.V.R., PLAY Level
vVR2	48079600	47kΩ S.V.R., REC Level
vVR50	48079800	100kΩ S.V.R., BIAS Level

4-7. F-4729 Cassette Half SW. Board
Component Side

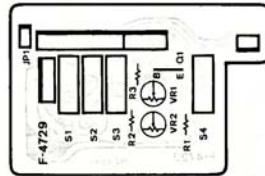

Parts List

Parts No.	Stock No.	Description
•Diode		
tD1	03111600	1S2473D
tS1	47292710	Leaf SW., half sensor
tS2	47292710	Leaf SW., prevention tab sensor < b-side Mechanism >
tS3	47292710	Leaf SW., tape sel. HIGH
tS4	47292710	Leaf SW., tape sel. METAL < b-side Mechanism >

5. OTHER PARTS

5-1. Front View

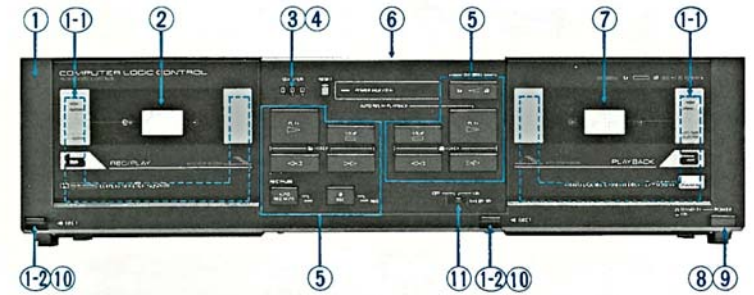

5-2. Top View

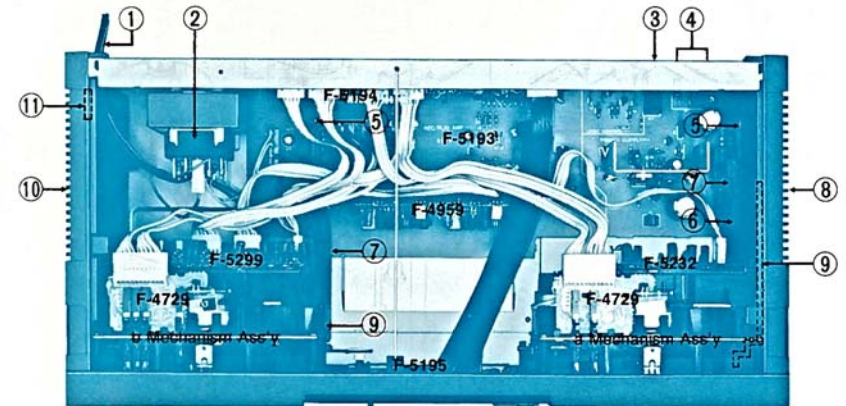

Parts List < Front View >

Parts No.	Stock No.	Description
1	27039100	Front Panel Ass'y
1-1	47678700	Cassette Holder Ass'y
1-2	47762000	EJECT Knob
2	27039400	b-Side Cassette Lid Ass'y
3	48192200	Tape Counter
4	47843300	Counter Belt
5	48113200	Push SW., PLAY-◀▶▶▶-STOP, etc.
6	47874700	Bonnet
7	27039300	a-Side Cassette Lid Ass'y
8	47747100	Push Knob, POWER
Δ 9	48172700	Push SW., POWER
10	47673000	Spring, EJECT
11	48158200	Slide SW., DOLBY NR

Parts List < Top View >

Parts No.	Stock No.	Description
Δ 1	38005400	Power Supply Cord (XX)
Δ	46604400	Power Supply Cord (UL,CSA)
Δ	07204200	Power Supply Cord (XX)
Δ 2	15022001	Power Transformer (AS)
Δ	15022002	Power Transformer (UL,CSA)
Δ	15022005	Power Transformer (AS)
3	46547200	Jack COMPU SELECTOR
4	46371500	4P Terminal Board, LINE IN/OUT
5	48126700	Damper Ass'y
6	47839610	Joint Shaft, POWER
7	47685320	Damper Holder
8	47874810	Right Side Panel
9	47628500	Joint Shaft, Damper Ass'y
10	47874900	Left Side Panel
11	47770900	Power Supply Cord Cover

6. EXPLODED VIEW OF MECHANISM ASS'Y & PARTS LIST

6-1. Front View of Mechanism Chassis

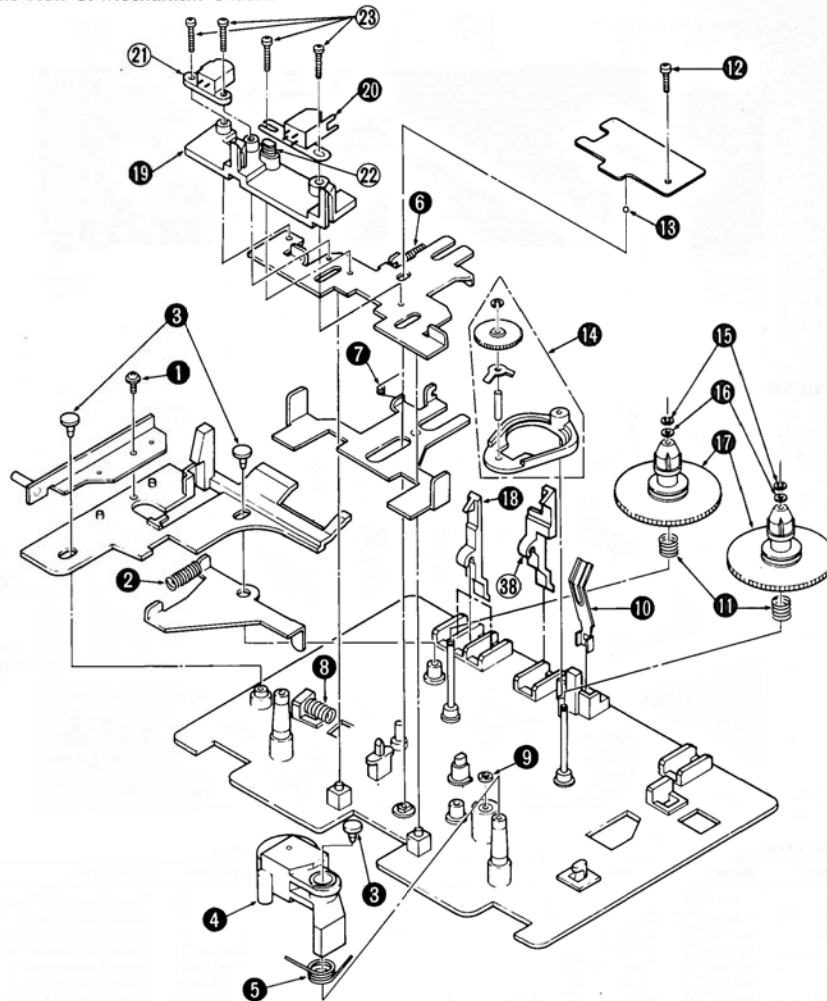

Parts List

Parts No.	Stock No.	Description
1	46267900	Tapping Screw, M3.0x8
2	47644500	Spring, eject
3	47420900	Plastic Tack
4	47281810	Pinch Roller Ass'y
5	47405500	Spring, pinch roller
6	47406200	Spring, head base
7	47405600	Spring, slide base
8	47668600	Spring, plunger solenoid
9	47404700	Washer, d = 2.5
10	47293510	Spring, half

Parts No.	Stock No.	Description
11	47709620	Spring, reel
12	13127800	Tapping Screw, M2x12
13	47404900	Steel Ball, $\phi 2.0$
14	47405000	Arm Ass'y
15	47404800	Washer, d = 1.6
16	47497100	Washer, d = 2.0
17	47835510	Reel Gear Ass'y
18	47723020	Sensor Arm (A)
19	47284110	Head Base
20	48001600	REC/PB Head

6-2. Rear View of Mechanism Chassis

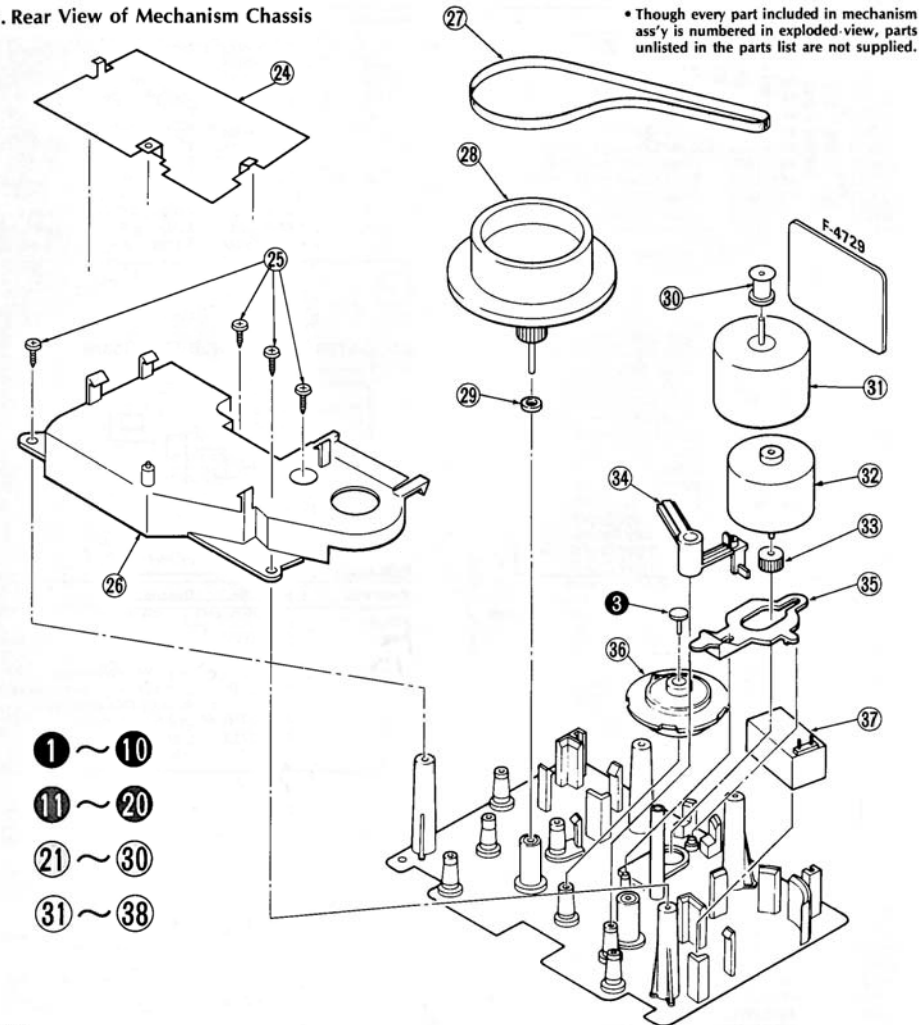

Parts List

Parts No.	Stock No.	Description
21	07997400	Erase Head <b-Mechanism>
	46867800	Dummy Head <a-Mechanism>
22	47406100	Spring azimuth
23	00420900	Binding Head Screw, M2x12
24		Shield Plate
25	46267800	Pan Head Tapping Screw, M3x8
26	47658030	Sub Chassis
27	47405100	Belt
28	47598110	Flywheel Ass'y
29	47404600	Washer, d = 2.5

Parts No.	Stock No.	Description
30	47897200	Pully
31	46737400	Capstan Motor
32	46737500	Reel Motor
33	47293110	Gear, reel motor
34	47281610	Lock Arm
35	47293810	Arm (B)
36	47283830	Assist Gear
37	47292610	Plunger Solenoid
38	47292530	Sensor Arm B <b-Mechanism>

7. MAIN PARTS REPLACEMENT

A. Bonnet (See Fig. 7-1)

- 1) Remove two screws ⑤.
- 2) Pull the rear side of the bonnet remove the hooks and then remove bonnet.

Fig. 7-1

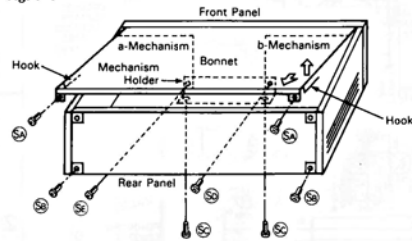

B. Bottom Plate

- 1) Remove four screws ⑥ (See Fig. 7-1).
 - 2) Pull the rear side of the bonnet and then remove it.
- Note:** Install the bottom plate after matching eject spring with point ④ of bottom plate (See Fig. 7-2).

Fig. 7-2

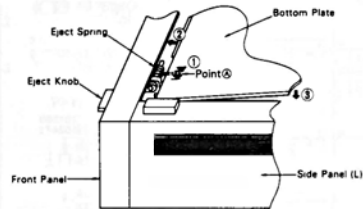

C. Side Panel L (R) (See Fig. 7-3)

- 1) Remove bonnet and bottom plate.
- 2) Shift the position of the side panel L (R) 2.0cm in the arrow direction ①.
- 3) Remove the hooks ② of the side panel from front panel and then pull it the arrow direction ③ to remove the side panel L (R).

Fig. 7-3

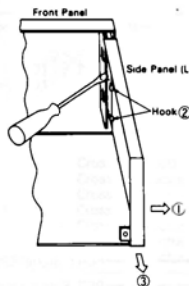

D. a-Side Mechanism Ass'y

- 1) Remove the bonnet, the bottom plate and tension wire.
- 2) Pluck out one connector from F-5193 board.
- 3) Extract one connector from the F-4729 circuit board.
- 4) Remove the side panel R.
- 5) Remove the joint shaft from the groove of the damper holder. (See L. Damper Ass'y)
- 6) Loosen a screw ⑦ fixing Mechanism Holder. (See Fig. 7-1)
- 7) Press the EJECT knob to open the cassette holder.
- 8) Remove four screws fixing the mechanism ass'y.
- 9) Remove the mechanism ass'y.

E. b-Side Mechanism Ass'y

- 1) Remove the bonnet and bottom plate.
 - 2) Pluck out three connectors from F-5193 board.
 - 3) Extract one connector from the F-4729 board.
 - 4) Remove the side panel L.
 - 5) Remove the joint shaft from the groove of the damper holder. (See L. Damper Ass'y)
 - 6) Loosen a screw ⑦ fixing Mechanism Holder. (See Fig. 7-1)
 - 7) Press the EJECT knob to open the cassette holder.
 - 8) Remove four screws fixing the mechanism ass'y.
 - 9) Draw out the mechanism ass'y.
- Note:** To attach the mechanism ass'y, put the counter belt at the reel groove.

F. Front Panel Ass'y

- 1) Remove the bonnet and bottom plate.
- 2) Remove the side panel (L) and (R).
- 3) Remove tension wire.
- 4) Pluck out F-5195 circuit board from front panel ass'y.
- 5) Remove the a & b mechanism ass'y and tape counter.

G. Cassette Lid Ass'y

Push EJECT Knob to open the cassette holder, push the parts locked at the left and right in the figure while pulling it upward, and remove the lid ass'y. (See Fig. 7-4)

Fig. 7-4

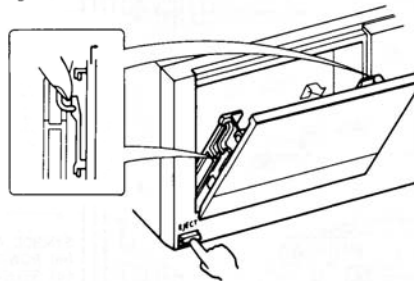

H. Rec/PB Head ⑩ (See Exploded View on Page 10)

- 1) Remove the mechanism ass'y from set.
- 2) Unsolder head read wires.
- 3) Loosen two screws.

I. Pinch Roller Ass'y ④ (See Exploded View on Page 10)

- 1) Remove the mechanism ass'y from set.
- 2) Pull out the lock pin ③.
- 3) Take out the pinchroller ass'y.

J. Reel Gear Ass'y ⑰ (See Exploded View on Page 10)

- 1) Remove the mechanism ass'y from set.
- 2) Take off two washer ⑱, ⑲ to pull out reel gear.

K. Capstan Motor ⑳, Reel Motor ㉑, Capstan Belt ㉒, Flywheel ㉓, Plunger Solenoid ㉔ (See Exploded View on Page 10)

- 1) Remove the mechanism ass'y from set.
- 2) Extract connectors on the F-5299 <b-side Mecha.> or F-5232 <a-side Mecha.> board.
- 3) Remove the F-5299 <b-side Mecha.> or F-5232 <a-side Mecha.> board from the mechanism ass'y.
- 4) Take out shield plate ㉕.
- 5) Loosen four screws ㉖ fastening sub chassis ㉗.

L. Damper Ass'y

- 1) Hold the damper holder to fix it, and push the damper ass'y to the arrow direction as Fig. 7-5, so that the damper ass'y is removed from the damper holder. (See Fig. 7-5)
- 2) Pinch the joint portion of the joint shaft and the damper ass'y, and remove the joint shaft from the groove of the damper holder after a little twist to the left. (See Fig. 7-6)
- 3) Turn up the damper end, to set the slit of the damper ass'y to the projection of the joint shaft. Then pull out the damper ass'y from the joint shaft. (See Fig. 7-7)

Fig. 7-5

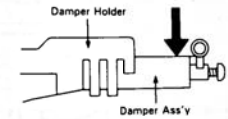

Fig. 7-6

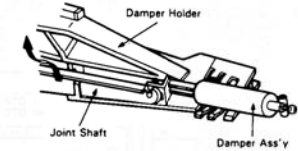
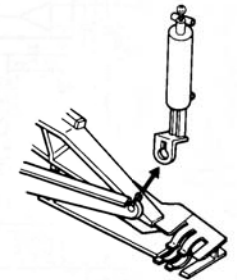
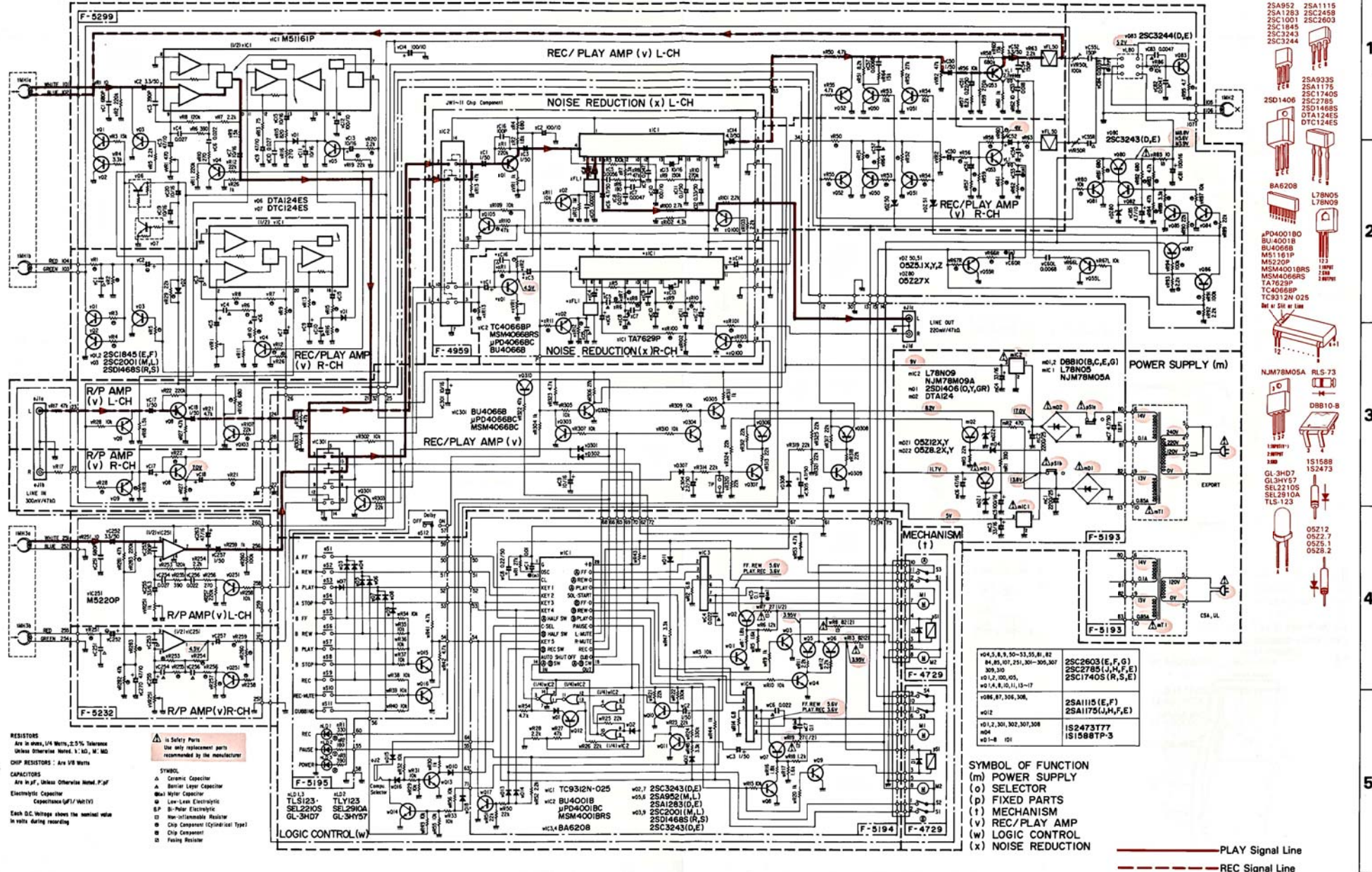

Fig. 7-7



8. SCHEMATIC DIAGRAM



9. INTERIOR BLOCK DIAGRAM OF IC

•TA7629P (B-type DOLBY Noise Reduction IC)

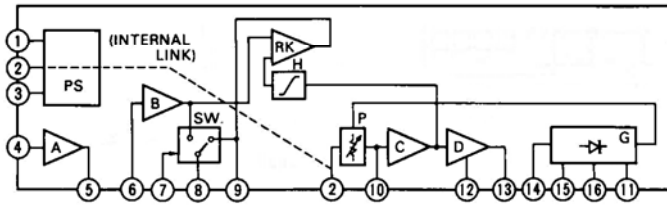

•BA6208 (Motor Drive IC)

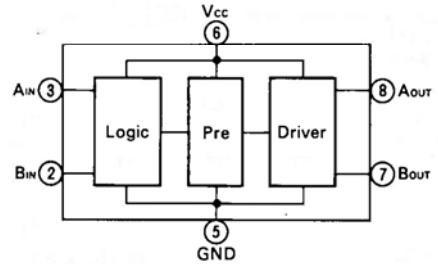

•M51161P (ALC & PLAY EQ. Amp. IC)

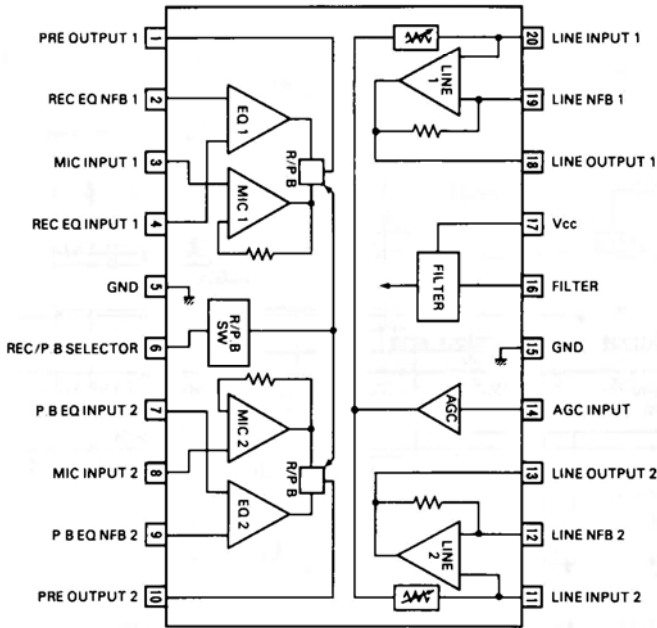

•BU4001B/MSM4001BRS/μPD4001BC (NOR IC)

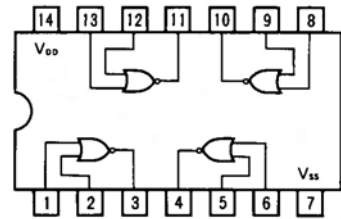

•BU4066B/MSM4066BRS/TC4066BP/μPD4066BC (Quad Analog SW. IC)

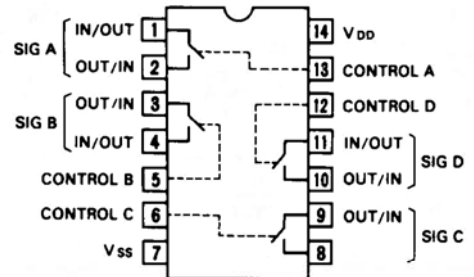

•TC9312N-025 (Logic Control IC)

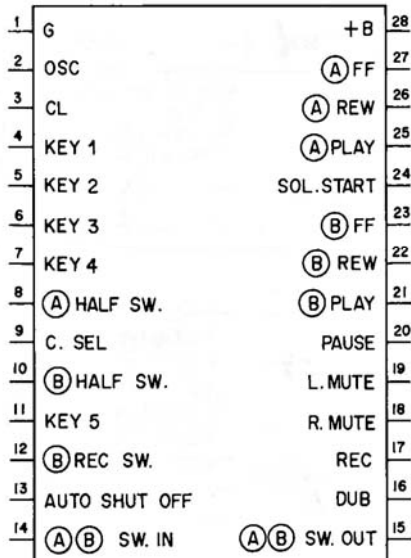

•M5220P (OP Amp. IC)

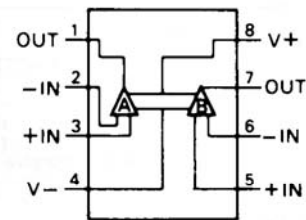

10. ADJUSTMENTS

10-1. Tape Speed Adjustment

Note: 1. Use Sansui Test Tape, SCT-3SK (3 kHz signals are recorded on the tape).
2. Connections are shown in Fig. 10-1.

Fig. 10-1

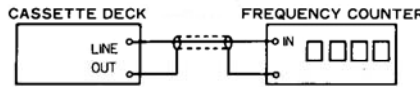
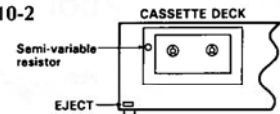

Fig. 10-2



STEP	SUBJECT	MEASURE OUTPUT	SETTING	ADJUSTMENT	ADJUST FOR	REMARKS
1.	A Side Mecha.	LINE OUT Frequency counter	Playback the TEST TAPE SCT-S3K. A Side Mecha	Turn semi-variable resistor of A Side Mecha. as Fig. 10-2.	3000Hz ± 45Hz	Use small screw driver.
2.	B Side Mecha.		Playback the TEST TAPE SCT-S3K. B Side Mecha.	Turn semi-variable resistor of B Side Mecha. as Fig. 10-2.	3000Hz ± 45Hz	

10-2. Playback Adjustment

Note: 1. Before this adjustment, clean REC/P.B. head surface.
2. For this adjustment, use Sansui Test Tape, SCT-F10K, and SCT-L400.
3. Set the Dolby NR switch to be OFF.
4. Connections are shown in Fig. 10-3.

Fig. 10-3

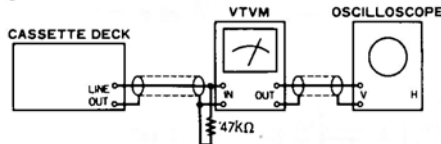
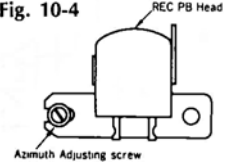

Fig. 10-4



1) b-Side Mecha. Adjustment

STEP	SUBJECT	MEASURE OUTPUT	SETTING	ADJUSTMENT	ADJUST FOR	REMARKS
1.	REC/P.B. Head Adj.	LINE OUT VTVM and Scope	Playback the TEST TAPE SCT-F10K	Adjust the azimuth adjusting screw in Fig. 10-4.	MAX. Output both channels.	Refer to removal of Lid Ass'y on Page 11. After this adjustment, lock the screw with paint.
2.	Playback Level Pre Adj.	Between Point Ⓐ (vC7L) and GND/Point Ⓑ (vC7R) and GND VTVM and Scope (F-4959)	Playback the TEST TAPE SCT-L400	Adjust each vVR1 (L-CH and R-CH, F-5299)	10mV ± 2dB	See Fig. 10-6 and 10-7 on Page 15.
3.	Playback Level Adj.	LINE OUT VTVM and Scope	Playback the TEST TAPE SCT-L400	Adjust each xVR1 (L-CH and R-CH, F-4959)	320mV ± 2dB	See Fig. 10-7 on Page 15.

2) a-Side Mecha. Adjustment

STEP	SUBJECT	MEASURE OUTPUT	SETTING	ADJUSTMENT	ADJUST FOR	REMARKS
1.	REC/P.B. Head Adj.	LINE OUT VTVM and Scope	Playback the TEST TAPE SCT-F10K	Adjust the azimuth adjusting screw in Fig. 10-4.	MAX. Output both channels.	Refer to removal of Lid Ass'y on Page 11. After this adjustment, lock the screw with paint.
2.	Playback Level Adj.	Same as above	Playback the TEST TAPE SCT-L400	Adjust each vVR251 (L-CH and R-CH, F-5232)	320mV ± 2dB	See Fig. 10-9 on Page 15.

◆ List of Sansui Test Tape

Name of TEST TAPE	Recorded Frequency	Description	Equivalent To
SCT-F40	40 Hz	Playback Frequency Response Check	—
SCT-F1K	1 kHz	High Frequency Equalization Check	—
SCT-F10K	10 kHz	REC/PB Head Adjustment	—
SCT-L400N	400 Hz	Playback Level and Indicator Level Adjustment	—
SCT-S3K	3 kHz	Speed Check and Wow & Flutter Check	—
*SCT-AD (NORMAL)	—	Recording Bias Adjustment	TDK AD
*SCT-SA (HIGH)	—	REC/PB Level Adjustment	TDK SA
*SCT-MA (METAL)	—	Frequency Response Check	TDK MA

Note: Some reference tapes marked * are not supplied. As these are equivalent to ones indicated above, please obtain these blank tapes on your side as possible.

10-3. REC Level & Frequency Response Adjustment <b Side Mecha. only>

- Note: 1. Connections are shown in Fig. 10-5.
 2. Set the Dolby NR switch to be OFF.
 3. Short between Test Pin Point © (F-5193) & Ground (See. Fig. 10-8)

Fig. 10-5

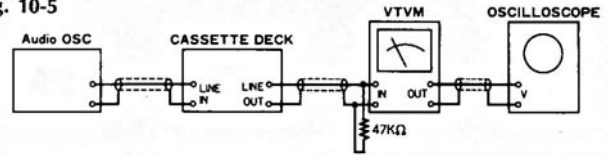

STEP	SUBJECT	MEASURE OUTPUT	SETTING	ADJUSTMENT	ADJUST FOR	REMARKS
1.	REC/Level Adj.	Feed 1 kHz from Audio S.G. into LINE IN.	LINE OUT, VTVM and Scope	Load the TEST TAPE SCT-SA. 1. Push the PAUSE, and REC knob. 2. Adjust the output level of Audio SG. for obtaining 225mV on VTVM. 3. Push the PAUSE knob, then record the 1kHz signal. 4. Playback the 1kHz signal. 5. Confirm that the output levels on both channels are 225mV ± 2dB on VTVM.	1. If not turn vVR2 (REC, L-CH, F-5299) and vVR2 (REC, R-CH, F-5299) until output level 225mV ± 2dB on both channels are obtained.	•See Fig. 10-6.
2.	Frequency Response Adj.	Feed 1kHz 10mV and 10kHz 10mV, from Audio S.G. into LINE IN.	Same as above	Load the TEST TAPE SCT-SA. 1. Record the 1kHz and 10kHz signals. 2. Playback the 1kHz and 10kHz signals, then confirm that both output levels equal.	1. If not, adjust vVR50 (F-5299) for L-CH and vVR50 (F-5299) for R-CH slightly until the output levels will be equal.	•See Fig. 10-6.

Fig. 10-6

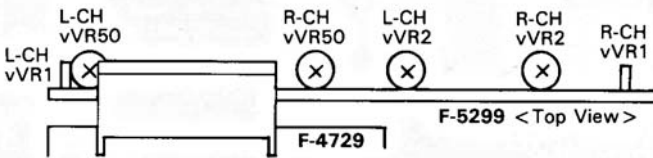
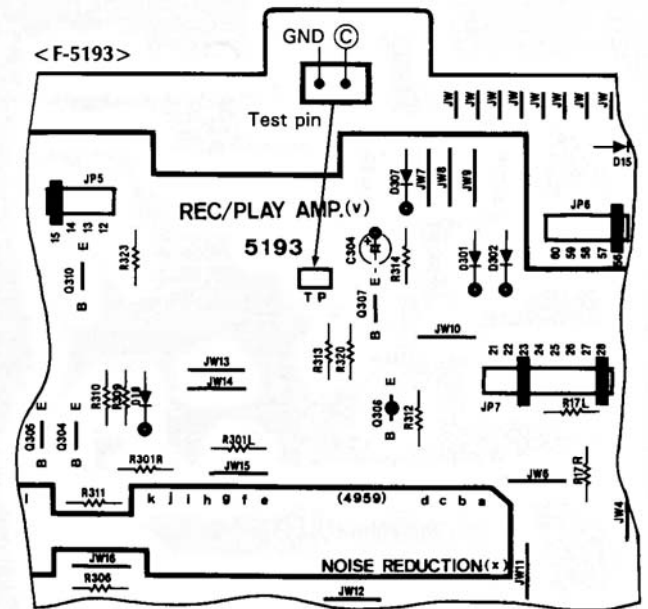
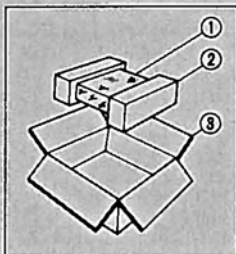

Fig. 10-8



11. PACKING LIST

Parts No.	Stock No.	Description
1	47859900	Vinyl Cover
2	47764620	Styrofoam Packing
3	27040100	Carton Case



12. ACCESSORY LIST

Stock No.	Description
07193400	PJP Cord
or 38103300	PJP Cord
48181300	Mini Pin Plug Cord (COMPU SELECTOR)
46989000	Operating Instruction



SANSUI ELECTRIC CO., LTD.:
 SANSUI ELECTRONICS CORPORATION:
 SANSUI ELECTRONICS (U.K.) LTD.:
 SANSUI ELECTRONICS G.M.B.H.:

14-1, Izumi 2-chome, Suginami-ku, Tokyo 168 Japan
 PHONE: (03) 324-8891/TELEX: 232-2076 (International Division)
 1250 Valley Brook Ave. Lyndhurst, N.J. 07071 U.S.A.
 17150 South Margay Ave. Carson, California 90746 U.S.A.
 3036 Koapaka Street, Honolulu, Hawaii 96819 U.S.A.
 Unit 10A, Lyon Industrial Estate, Rockware Avenue, Greenford, Middx UB6, OAA, England
 Pau Ehrich Strasse 8, 6074 Rödermark 2, West Germany