

SERVICE MANUAL

STEREO DOUBLE CASSETTE DECK

SANSUI D-70BW



CAUTION

1. Parts identified by the \triangle symbol on the schematic diagram and the parts list are critical for safety. Use only replacement parts that have critical characteristics recommended by the manufacturer.
2. Make leakage-current or resistance measurements to determine that exposed parts are acceptably insulated from the supply circuit before returning the appliance to the customer.

•SPECIFICATIONS

Track format	4-track/2-channel system
Tape speed	4.8 cm/sec.
Heads	
Rec/play head	HIGH-Bs hard permalloy
Play head	HIGH-Bs hard permalloy
Erase head	Double-gap HIGH-Bs ferrite
Motor	
	Electronically controlled DC motor $\times 2$ (2 speed)
	Reels: DC Motor $\times 2$
Wow/flutter	0.06% max (WRMS)
Fast forwarding (rewinding) time	
	Approx. 90 sec. (for C-60 tape)
Frequency response (—20 VU recording/playback)	
Normal tape (LH)	20 to 15,000 Hz (30 to 14,000 Hz ± 3 dB)
Chrome Tape	20 to 16,000 Hz (30 to 15,000 Hz ± 3 dB)
Metal Tape	20 to 17,000 Hz (30 to 16,000 Hz ± 3 dB)
Erasure rate (metal tape)	
	70 dB min (1 kHz)
Recording bias frequency	
	105 kHz
Input sensitivity/impedance	
LINE IN (REC)	300 mV/47 kohms
Signal to noise ratio (Record/Playback)	
Metal Tape (without Dolby Noise Reduction)	
DOLBY NR OFF	Better than 54 dB
DOLBY NR ON	Better than 64 dB
Power requirements	
Power voltage	110/120/220/240V (50/60 Hz)
	For U.S.A. and Canada
	120V (60 Hz)
Power consumption	20 watts
Dimensions	
	430 mm (16-15/16") W
	112 mm (4-7/16") H
	221 mm (8-3/4") D
Weight	4.0 kg (8.8 lbs.) net
* Design and specifications subject to changes without notice for improvements.	
* Due to local laws and regulations, this unit sold in some areas are not equipped with variable voltage selectors	

Sansui

SANSUI ELECTRIC CO., LTD.

CAUTION

1. The symbols, UL, CSA, SA, BS, UK, EU, AS and XX (EXPORT) on the parts list and the schematic diagram mean followings respectively.
 - UL..... Manufactured for U.S.A market.
(Underwriters Laboratories approved model.)
 - CSA..... Manufactured for Canadian market.
 - SA..... Manufactured for South African market.
 - BS, UK Manufactured for United Kingdom market.
 - EU Manufactured for European market.
 - AS..... Manufactured for Australian market.
 - XX (EXPORT) Standard Version.
 - NON MARK Common Parts.

2. Some printed circuit boards are not supplied assembled.
To separate these in this service manual, the stock numbers are not indicated for these boards. However, stock numbers for individual parts are indicated.

3. Since some of capacitors and resistors are omitted from parts lists in this service manual, refer to the Common Parts List for capacitors & resistors, which was issued on February 1983.

4. Abbreviations in this service manual are as follows.

•Abbreviations List

C.R.	: Carbon Resistor	E.B.	: Bi-Polar Electrolytic Capacitor
S.R.	: Solid Resistor	E.B.L.	: Low Leakage Bi-Polar Electrolytic Capacitor
W.R.	: Wire Wound Resistor	Ta.C.	: Tantalum Capacitor
M.R.	: Metal Film Resistor	F.C.	: Film Capacitor
F.R.	: Fusing Resistor	M.P.	: Metallized Paper Capacitor
N.I.R.	: Non-Inflammable Resistor	P.C.	: Polystyrene Capacitor
R.A.	: Resistor Array	C.A.	: Capacitor Array
C.C.	: Ceramic Capacitor	V.R.	: Variable Resistor
C.T.	: Ceramic Capacitor, Temperature Compensation	SW.	: Switch
E.C.	: Electrolytic Capacitor	Chip R.	: Chip Resistor
E.L.	: Low Leakage Electrolytic Capacitor	Chip C.	: Chip Capacitor

1. BLOCK DIAGRAM

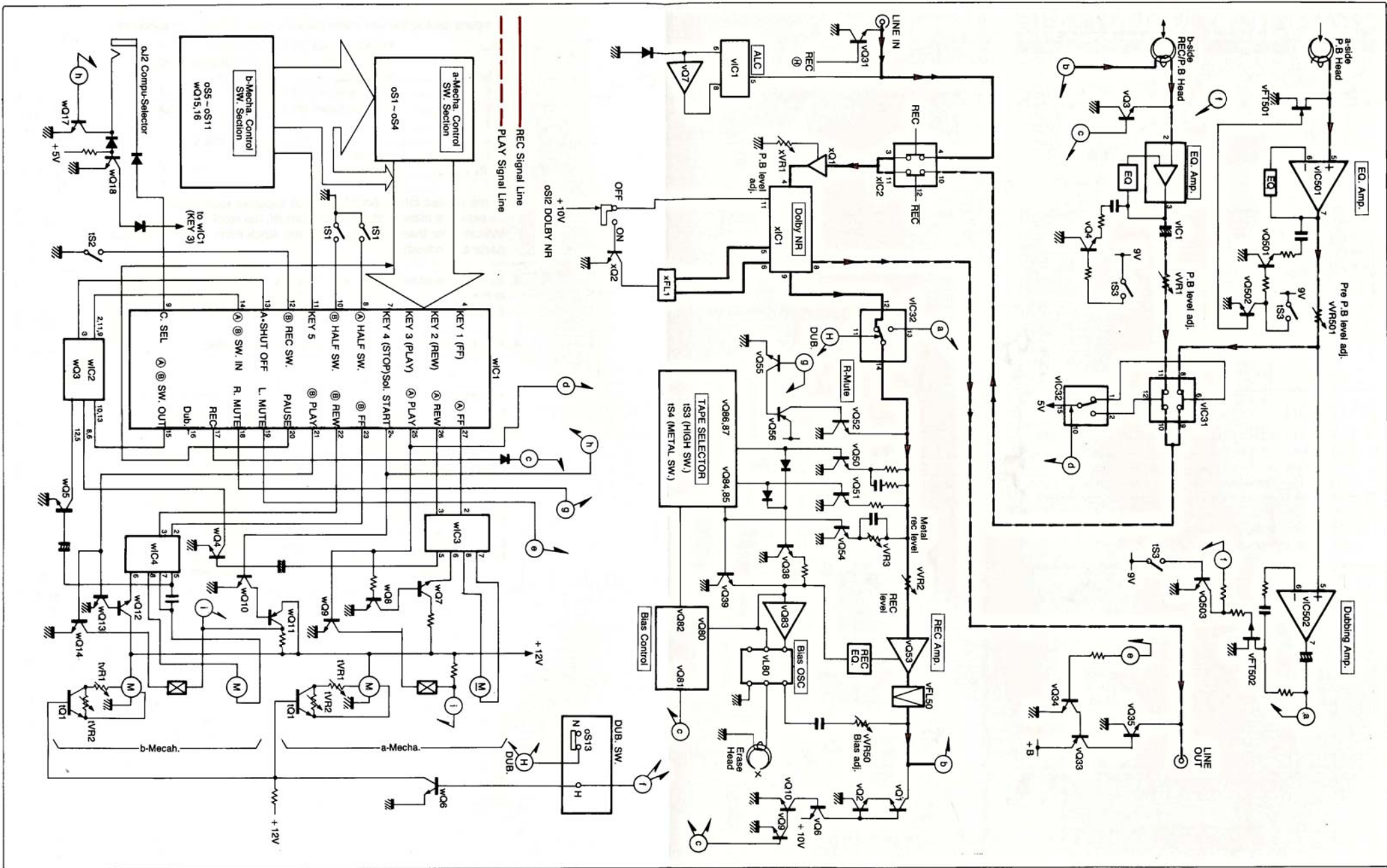

2. OPERATIONS OF PINCH ROLLER

2-1. Torque Transportation Flowchart

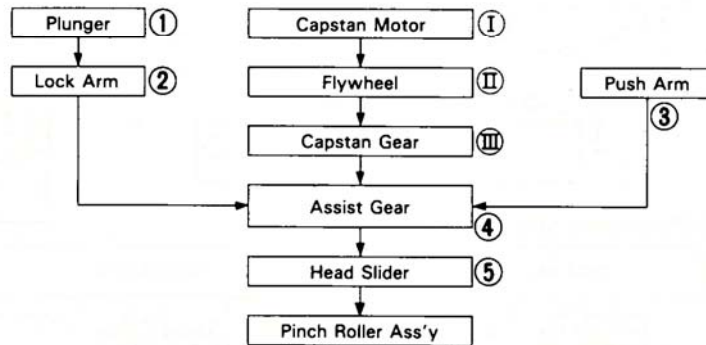

2-2. Front View of Mechanism Chassis

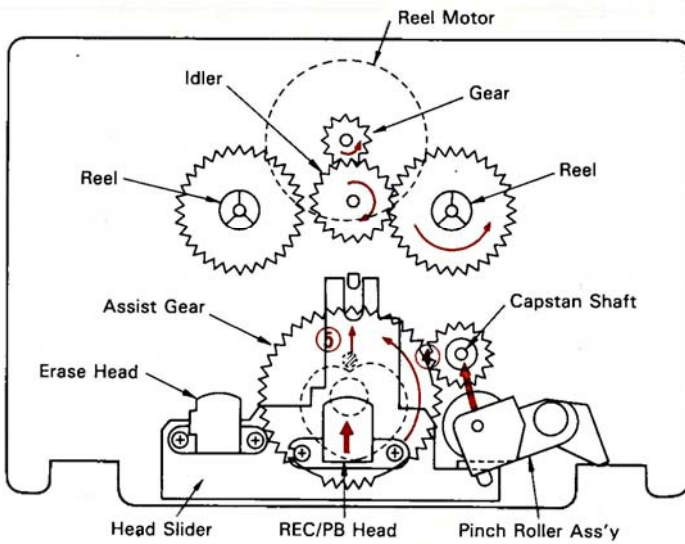

2-4. Cam Positions in the Modes of PLAY, FF, REW & STOP

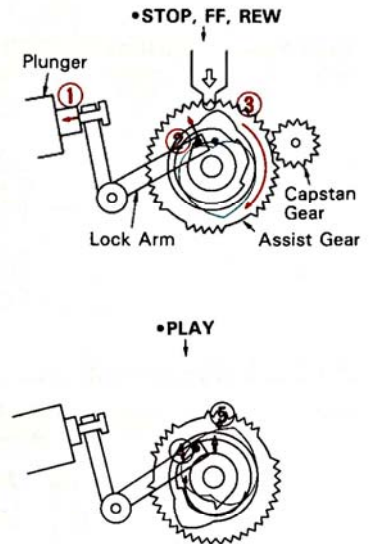

2-3. Rear View of Mechanism Chassis

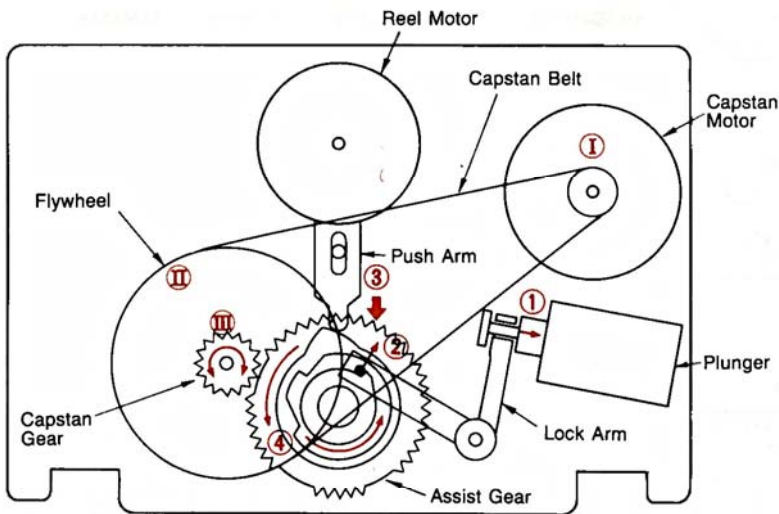

3. ADJUSTMENTS

3-1. Tape Speed Adjustment

- Adjust the tape speed of b-side as fast as a-side.
- Note:** 1. Use Sansui Test Tape, SCT-S3K. (3 kHz signals are recorded on the tape).
2. Connections are shown in Fig. 3-1.

Fig. 3-1

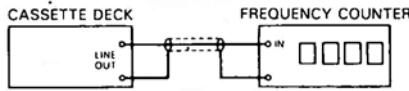
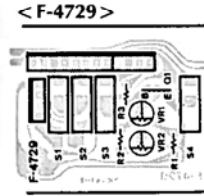

Fig. 3-2



1) Tape Speed Adjustment (NORMAL SPEED)

STEP	SUBJECT	MEASURE OUTPUT	SETTING	ADJUSTMENT	ADJUST FOR	REMARKS
1.	A Side Mecha. (NORMAL)	LINE OUT Frequency counter	Playback the TEST TAPE SCT-S3K. A Side Mecha.	Turn semi-variable resistor (tVR1) of A Side Mecha. as Fig. 3-2.	3000Hz $\begin{matrix} +30 \\ -0 \end{matrix}$ Hz	Use small screw driver.
2.	B Side Mecha. (NORMAL)		Playback the TEST TAPE SCT-S3K. B Side Mecha.	Turn semi-variable resistor (tVR1) of B Side Mecha. as Fig. 3-2.	3000Hz $\begin{matrix} +30 \\ -0 \end{matrix}$ Hz	

2) Tape Speed Adjustment (HIGH SPEED)

- Note:** 1. Before this adjustment, regulate "3-1. Tape Speed Adjustment (NORMAL SPEED)".
2. Short between the R3 on F-4729 & GND. (See Fig. 3-2)

STEP	SUBJECT	MEASURE OUTPUT	SETTING	ADJUSTMENT	ADJUST FOR	REMARKS
1.	A Side Mecha. (HIGH)	LINE OUT Frequency counter	Playback the TEST TAPE SCT-S3K. A Side Mecha.	Turn semi-variable resistor (tVR2) of A Side Mecha. as Fig. 3-2.	6000Hz $\begin{matrix} +60 \\ -0 \end{matrix}$ Hz	Use small screw driver.
2.	B Side Mecha. (HIGH)		Playback the TEST TAPE SCT-S3K. B Side Mecha.	Turn semi-variable resistor (tVR2) of B Side Mecha. as Fig. 3-2.	6000Hz $\begin{matrix} +60 \\ -0 \end{matrix}$ Hz	

3-2. Playback Adjustment

- Note:** 1. Before this adjustment, clean REC/P.B. head surface.
2. For this adjustment, use Sansui Test Tape, SCT-F10K, and SCT-L400.
3. Set the Dolby NR switch to be OFF.
4. Connections are shown in Fig. 3-3.

Fig. 3-3

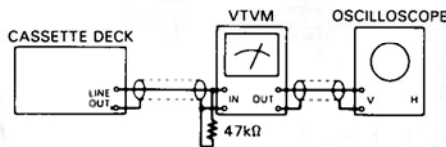
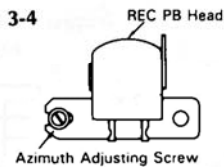

Fig. 3-4



1) a-Side Mecha. Adjustment

STEP	SUBJECT	MEASURE OUTPUT	SETTING	ADJUSTMENT	ADJUST FOR	REMARKS
1.	REC/P.B. Head Adj.	LINE OUT VTVM and Scope	Playback the TEST TAPE SCT-F10K	Adjust the azimuth adjusting screw in Fig. 3-4.	MAX. Output both channels on FWD and REV PLAY	Refer to removal of Lid Ass'y on Page 7. After this adjustment, lock the screw with paint.
2.	Playback Level Pre Adj.	Between across vR509 (L-CH and R-CH, F-5397) VTVM and Scope	Playback the TEST TAPE SCT-L400	Adjust each vVR501 (L-CH and R-CH, F-5397)	10mV \pm 2dB	See Fig. 3-6 on Page 5.
3.	Playback Level Adj.	LINE OUT VTVM and Scope	Playback the TEST TAPE SCT-L400	Adjust each xVR1 (L-CH and R-CH, F-5336)	320mV \pm 2dB	See Top View on Page 16.

2) b-Side Mecha. Adjustment

STEP	SUBJECT	MEASURE OUTPUT	SETTING	ADJUSTMENT	ADJUST FOR	REMARKS
1.	REC/P.B. Head Adj.	LINE OUT VTVM and Scope	Playback the TEST TAPE SCT-F10K	Adjust the azimuth adjusting screw in Fig. 3-4.	MAX. Output both channels on FWD and REV PLAY	Refer to removal of Lid Ass'y on Page 7. After this adjustment, lock the screw with paint.
2.	Playback Level Adj.	LINE OUT VTVM and Scope	Playback the TEST TAPE SCT-L400	Adjust each vVR1 (L-CH and R-CH, F-5124)	320mV \pm 2dB	See Top View on Page 16.

3-3. REC Level & Frequency Response Adjustment <b Side Mecha. only>

Note: 1. Connections are shown in Fig. 3-5.
 2. Set the Dolby NR switch to be OFF.
 3. Short between TP terminal pins on F-5467 (See Top View on page 16).

Fig. 3-5

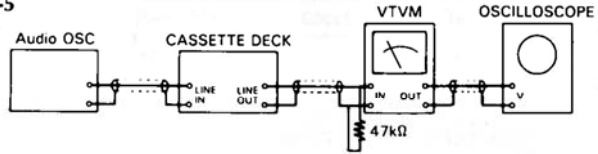

STEP	SUBJECT	INPUT SIGNAL	MEASURE OUTPUT	SETTING	ADJUSTMENT	REMARKS
1.	REC Level Adj.	Feed 1kHz from Audio S.G. into LINE IN.	LINE OUT, VTVM and Scope	Load the TEST TAPE SCT-SA. 1. Push the PAUSE, and REC knob. 2. Adjust the output level of Audio S.G. for obtaining 200mV on VTVM. 3. Push the PAUSE knob, then record the 1kHz signal. 4. Playback the 1kHz signal. 5. Confirm that the output levels on both channels are 200mV ± 2dB on VTVM.	1. If not turn vVR2 (REC, L-CH, F-5124) and vVR2 (REC, R-CH, F-5124) until output level 200mV ± 2dB on both channels are obtained.	vVR2 (REC, L-CH) and vVR2 (REC, R-CH) are shown in Top View on Page 16.
2.	Frequency Response Adj.	Feed 1kHz 10mV and 10kHz 10mV, from Audio S.G. into LINE IN.	Same as above	Load the TEST TAPE SCT-SA. 1. Record the 1kHz and 10kHz signals. 2. Playback the 1kHz and 10kHz signals, then confirm that both output levels equal.	1. If not, adjust vVR50 (F-5124) for L-CH and vVR50 (F-5124) for R-CH slightly until the output levels will be equal.	
3.	METAL REC Level Adj.	Feed 1kHz from Audio S.G. into LINE IN.	LINE OUT, VTVM and Scope	Load the TEST TAPE SCT-MA. 1. Push the PAUSE, and REC knob. 2. Adjust the output level of Audio S.G. for obtaining 200mV on VTVM. 3. Push the PAUSE knob, then record the 1kHz signal. 4. Playback the 1kHz signal. 5. Confirm that the output levels on both channels are 200mV ± 2dB on VTVM.	1. If not turn vVR3 (METAL, L-CH, F-5124) and vVR3 (METAL, R-CH, F-5124) until output level 200mV ± 2dB on both channels are obtained.	vVR3 (METAL, L-CH) and vVR3 (METAL, R-CH) are shown in Top View on page 16.

◆ List of Sansui Test Tape

Name of TEST TAPE	Recorded Frequency	Description	Equivalent To
SCT-F40	40 Hz	Playback Frequency Response Check	—
SCT-F1K	1 kHz	High Frequency Equalization Check	—
SCT-F10K	10 kHz	REC/PB Head Adjustment	—
SCT-L400N	400 Hz	Playback Level and Indicator Level Adjustment	—
SCT-S3K	3 kHz	Speed Check and Wow & Flutter Check	—
*SCT-AD (NORMAL)	—	Recording Bias Adjustment	TDK AD
*SCT-SA (HIGH)	—	REC/PB Level Adjustment	TDK SA
*SCT-MA (METAL)	—	Frequency Response Check	TDK MA

***Note:** Some reference tapes marked * are not supplied. As these are equivalent to ones indicated above, please obtain these blank tapes on your side as possible.

Fig. 3-6 <F-5397>

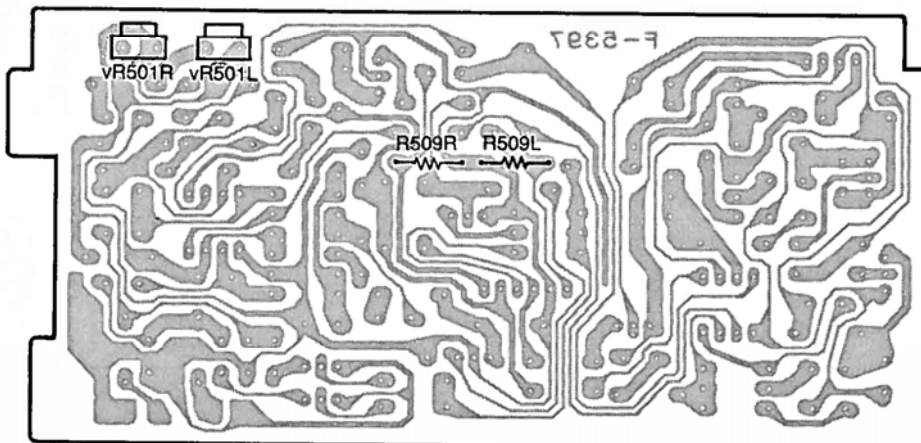

4. MAIN PARTS REPLACEMENT

A. Bonnet (See Fig. 4-1)

- 1) Remove two screws ⑤.
- 2) Pull the rear side of the bonnet remove the hooks and then remove bonnet.

B. Bottom Plate

- 1) Remove four screws ⑥ ⑦ (See Fig. 4-1).
- 2) Pull the rear side of the bonnet and then remove it.

Note: Install the bottom plate after matching eject spring with point ④ of bottom plate (See Fig. 4-2).

C. Side Panel L (R) (See Fig. 4-3)

- 1) Remove bonnet and bottom plate.
- 2) Shift the position of the side panel L (R) 2.0cm in the arrow direction ①.
- 3) Remove the hooks ② of the side panel from front panel and then pull it the arrow direction ③ to remove the side panel L (R).

D. a-Side Mechanism Ass'y

- 1) Remove the bonnet, the bottom plate and tension wire.
- 2) Pluck out two connectors from F-5397 board.
- 3) Extract one connector from the F-4729 circuit board.
- 4) Remove the side panel R.
- 5) Remove the joint shaft of power switch.
- 6) Remove the joint shaft from the groove of the damper holder. (See G. Damper Ass'y)
- 7) Loosen a screw ⑤ fixing Mechanism Holder. (See Fig. 4-1)
- 8) Press the EJECT knob to open the cassette holder.
- 9) Remove four screws fixing the mechanism ass'y.
- 10) Remove the mechanism ass'y.

E. b-Side Mechanism Ass'y

- 1) Remove the bonnet and bottom plate.
- 2) Pluck out four connectors from F-5124 board.
- 3) Extract one connector from the F-4729 board.
- 4) Remove the side panel L.
- 5) Remove the joint shaft from the groove of the damper holder. (See G. Damper Ass'y)
- 6) Loosen a screw ⑤ fixing Mechanism Holder. (See Fig. 4-1)
- 7) Take off a counter belt at the counter pulley.
- 8) Press the EJECT knob to open the cassette holder.
- 9) Remove four screws fixing the mechanism ass'y.
- 10) Draw out the mechanism ass'y.

Note: To attach the mechanism ass'y, put the counter belt at the reel groove.

F. Front Panel Ass'y

- 1) Remove the a-mechanism ass'y and the b-mechanism ass'y.
- 2) Remove the eject springs.
- 3) Remove the F-5469 board.
- 4) Take out the tape counter.

Fig. 4-1

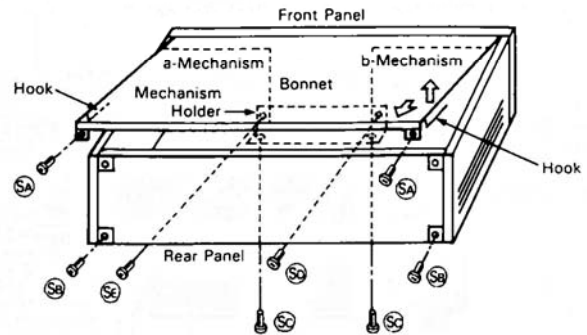

Fig. 4-2

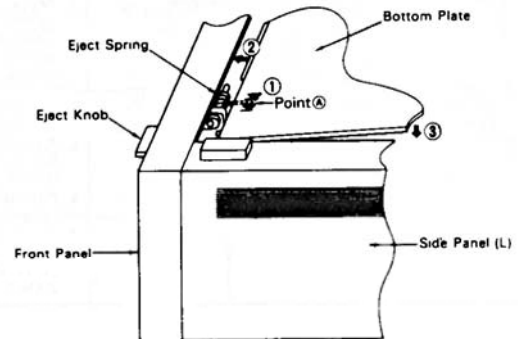
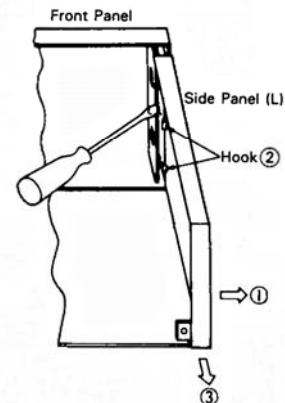

Fig. 4-3



G. Damper Ass'y

- 1) Hold the damper holder to fix it, and push the damper ass'y to the arrow direction as Fig. 4-4, so that the damper ass'y is removed from the damper holder. (See Fig. 4-4)
- 2) Pinch the joint portion of the joint shaft and the damper ass'y, and remove the joint shaft from the groove of the damper holder after a little twist to the left. (See Fig. 4-5)
- 3) Turn up the damper end, to set the slit of the damper ass'y to the projection of the joint shaft. Then pull out the damper ass'y from the joint shaft. (See Fig. 4-6)

H. Rec/PB Head ⑳

- 1) Remove the mechanism ass'y from set.
- 2) Unsolder head read wires.
- 3) Loosen two screws.

I. Pinch Roller Ass'y ④

- 1) Remove the mechanism ass'y from set.
- 2) Pull out the lock pin ③.
- 3) Take out the pinchroller ass'y.

J. Reel Gear Ass'y ⑰

- 1) Remove the mechanism ass'y from set.
- 2) Take off two washer ⑱, ⑲ to pull out reel gear.

K. Capstan Motor ⑳, Reel Motor ㉓, Capstan Belt ㉔, Flywheels ㉕ or ㉖ and Plunger ㉗
(See Exploded View of Mechanism Ass'y on Page 10, 11)

- 1) Remove a-side or b-side mechanism ass'y from set.
- 2) Remove the F-5397 board from a-side mechanism ass'y or the F-5123 board from b-side mechanism ass'y.
- 3) Remove the sub-chassis ㉘.

* When reassembling these removed parts, take the following precaution: Assemble the push (A) so that these parts are mutually positioned as shown in 2. OPERATIONS OF PINCHROLLER. Unless positioned correctly, the mechanism ass'y may be operated erroneously. Remember that if the push arm (A) is positioned on the assist gear (A), the eject arm may be locked.

L. Cassette Lid Ass'y

Push EJECT Knob to open the cassette holder, push the parts locked at the left and right in the figure while pulling it upward, and remove the lid ass'y. (See Fig. 4-7)

Fig. 4-4

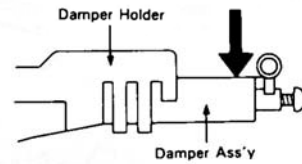

Fig. 4-5

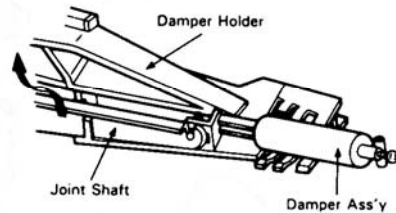

Fig. 4-6

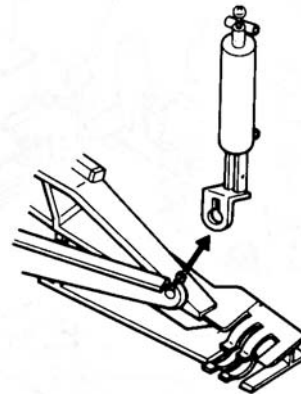
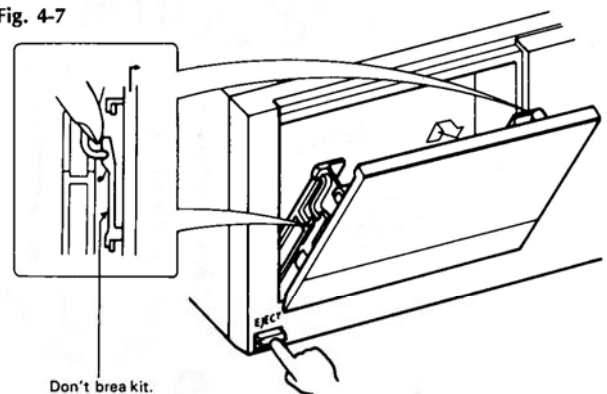

Fig. 4-7



5. EXPLODED VIEW OF MECHANISM ASS'Y & PARTS LIST

5-1. Front View of Mechanism Chassis

• Though every part included in mechanism ass'y is numbered in exploded view, parts unlisted in parts list are not supplied.

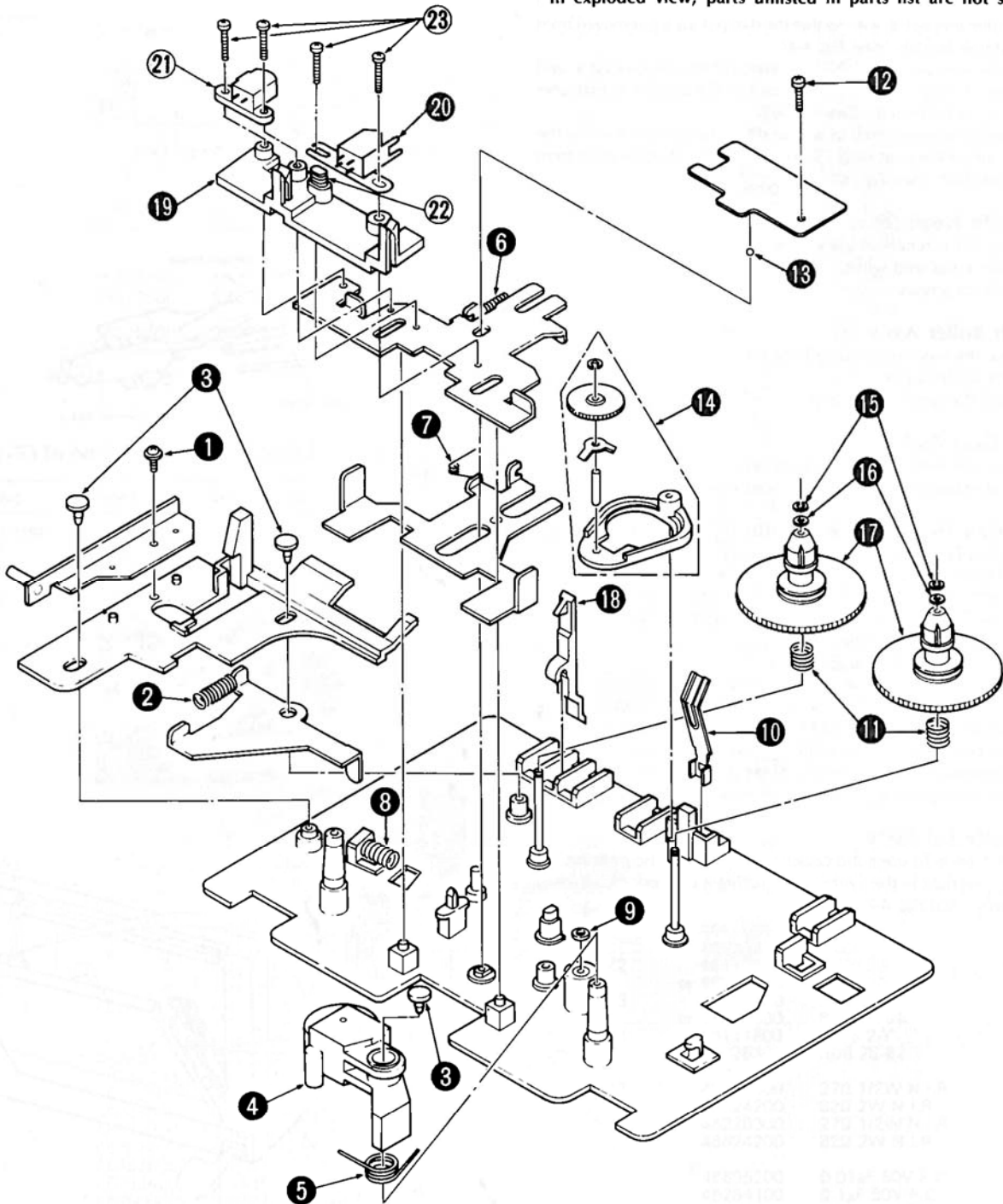

Parts List

Parts No.	Stock No.	Description
1	46267800	Tapping Screw, M3.0X8
2	47644500	Spring, eject
3	47420900	Plastic Tack
4	47281810	Pinch Roller Ass'y
5	47483100	Spring, pinch roller
6	47406200	Spring, head base
7	47405600	Spring, slide base
8	47668600	Spring, plunger solenoid
9	47404700	Washer, d=2.5
10	47293510	Spring, half

Parts No.	Stock No.	Description
11	47709620	Spring, reel
12	18139300	Tapping Screw, M2X12
13	47404900	Steel Ball, ϕ 2.0
14	47405000	Arm Ass'y
15	27083100	Washer, d=1.6
16	47497100	Washer, d=2.0
17	47835510	Reel Gear Ass'y
18	47723020	Sensor Arm (A)
19	47284110	Head Base
20	48001600	REC/PB Head

5-2. Rear View of Mechanism Chassis

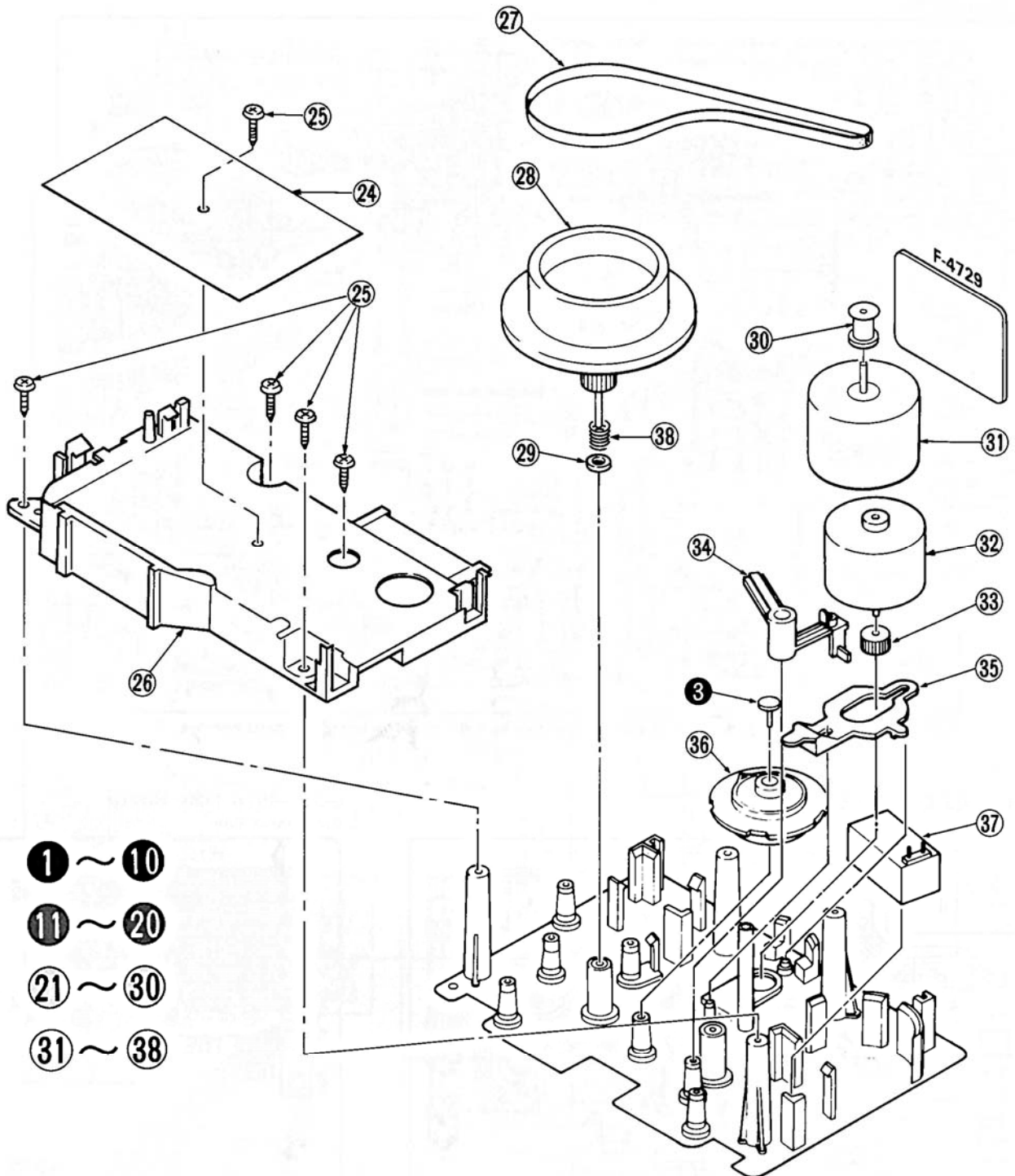

- ① ~ ⑩
- ⑪ ~ ⑳
- ㉑ ~ ㉓
- ㉔ ~ ㉘

Parts No.	Stock No.	Description
21	07997400	Erase Head (b-side)
22	46867800	Dummy Head (a-side)
23	47406100	Spring azimuth
24	00420900	Binding Head Screw, M2X12
25		Shield Plate
26	46267800	Pan Head Tapping Screw, M3X8
27	27218300	Sub Chassis
28	47405200	Belt
29	48399900	Flywheel Ass'y
	47404600	Washer, d=2.5

Parts No.	Stock No.	Description
30	47897100	Pulley
31	46737600	Capstan Motor
32	46737500	Reel Motor
33	47293110	Gear, reel motor
34	47281610	Lock Arm
35	47293810	Arm (B)
36	47283840	Assist Gear
37	47292610	Plunger Solenoid
38	47530000	Spring, flywheel

6. PARTS LOCATION OF BOARDS SECTION

6-1. F-5124 B-side REC/PLAYBACK Amp. Board
Component Side

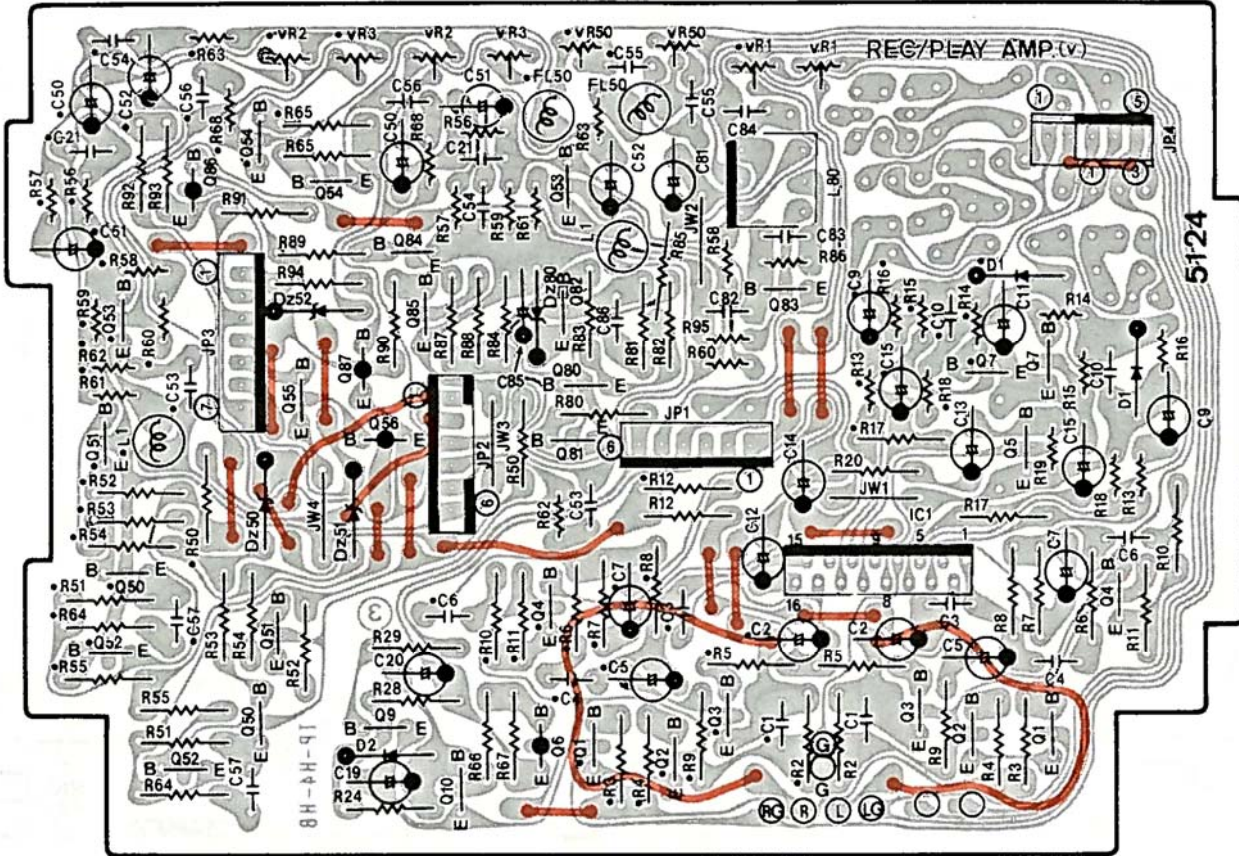

•Note: On this circuit board, the right channel is specified by "●" mark on top of the parts number.

6-2. F-5469 Control Switch Board
Component Side

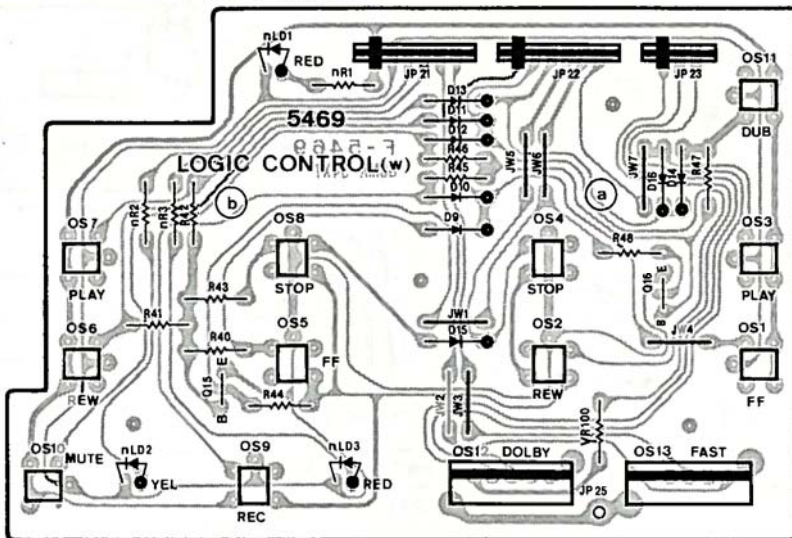

6-3. F-4916 Fuse Board
Component Side

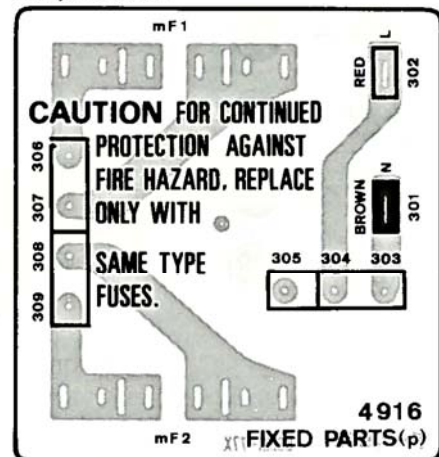

7. OVERALL WIRING DIAGRAM

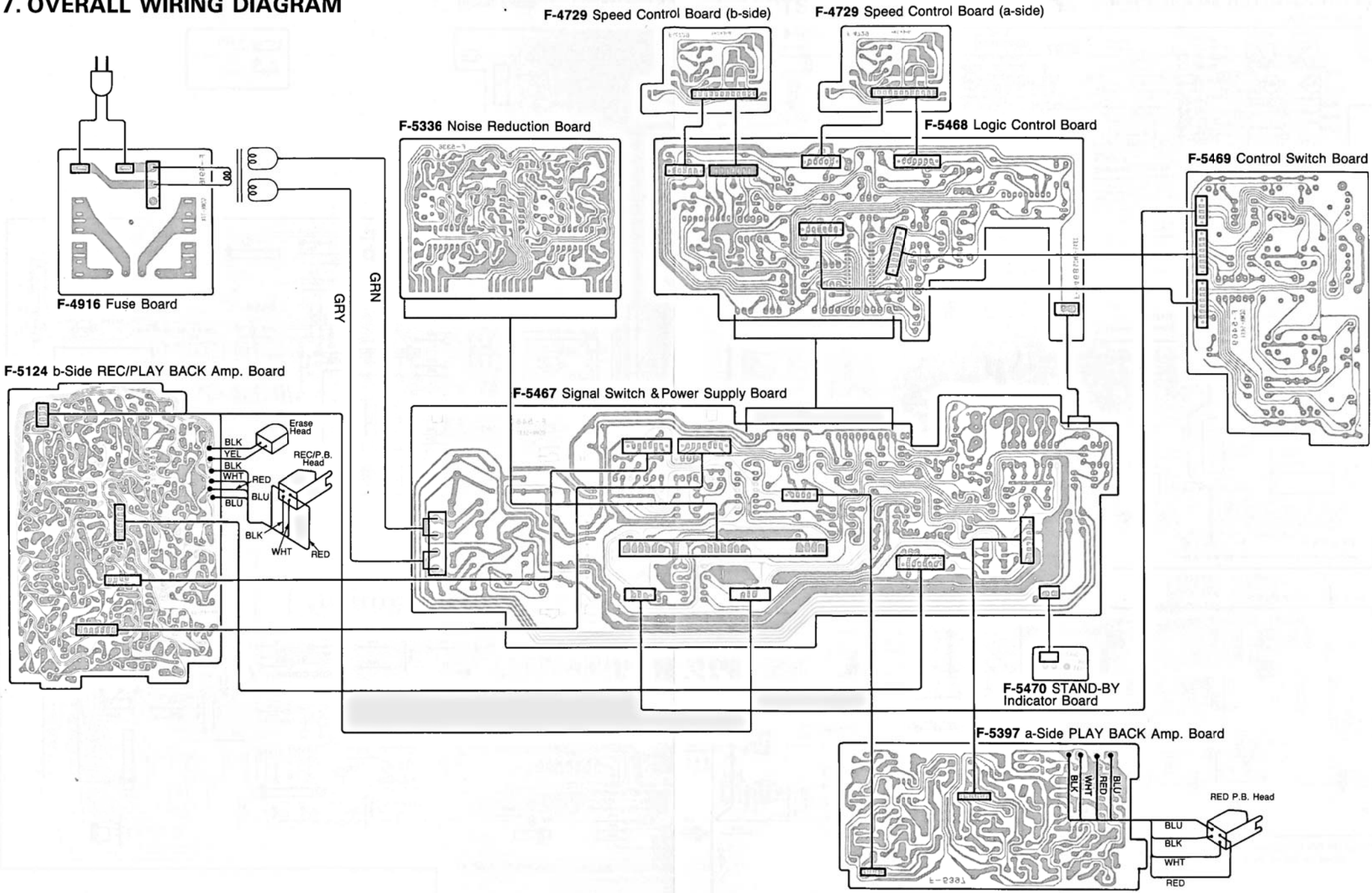

8. ELECTRIC PARTS LIST

8-1. F-5124 B-side REC/PLAYBACK Amp. Board (Stock No. 00993201)

Parts No.	Stock No.	Description
•Transistor		
vQ1	46581701	2SC1845
vQ2	46581701	2SC1845
vQ3	46359801	2SC2001
	or 48055901	2SD1468S
vQ4	46367101	2SC2603
	or 46367301	2SC2458
	or 48058801	2SC1740S
vQ5	46367101	2SC2603
	or 46367301	2SC2458
	or 48058801	2SC1740S
vQ6	46581601	2SA992
vQ7	46367101	2SC2603
	or 46367301	2SC2458
	or 48058801	2SC1740S
vQ9	46367101	2SC2603
	or 46367301	2SC2458
	or 48058801	2SC1740S
vQ10	46719900	DTC124ES
vQ50	46367101	2SC2603
	or 46367301	2SC2458
	or 48058801	2SC1740S
vQ51	46367101	2SC2603
	or 46367301	2SC2458
	or 48058801	2SC1740S
vQ52	46367101	2SC2603
	or 46367301	2SC2458
	or 48058801	2SC1740S
vQ53	46367101	2SC2603
	or 46367301	2SC2458
	or 48058801	2SC1740S
vQ54	46367101	2SC2603
	or 46367301	2SC2458
	or 48058801	2SC1740S
vQ55	46367101	2SC2603
	or 46367301	2SC2458
	or 48058801	2SC1740S
vQ56	46719800	DTA124ES
vQ80	46614101	2SC3243
vQ81	46367101	2SC2603
	or 46367301	2SC2458
	or 48058801	2SC1740S
vQ82	46367101	2SC2603
	or 46367301	2SC2458
	or 48058801	2SC1740S
vQ83	46725801	2SC1627A
	or 48061801	2SC3244
vQ84	46367101	2SC2603
	or 46367301	2SC2458
	or 48058801	2SC1740S
vQ85	46367101	2SC2603
	or 46367301	2SC2458
	or 48058801	2SC1740S
vQ86	46367001	2SA1115
	or 46392001	2SA1175
	or 48058801	2SA933S
vQ87	46367001	2SA1115
	or 46392001	2SA1175
	or 48058801	2SA933S
•IC		
vIC1	48365900	M51542L
•Diode		
vD1	03117600	1S2473T77
	or 46086000	1S1588TP-3
vD2	03117600	1S2473T77
	or 46086000	1S1588TP-3
•Zener Diode		
vDZ50	46111100	05Z5.1-X
	or 46111200	05Z5.1-Y
	or 46111300	05Z5.1-Z
vDZ51	46111100	05Z5.1-X
	or 46111200	05Z5.1-Y
	or 46111300	05Z5.1-Z
vDZ52	46111100	05Z5.1-X
	or 46111200	05Z5.1-Y
	or 46111300	05Z5.1-Z
vDZ80	46108800	05Z2.4-X
	or 46822800	RD2.4E-B

Parts No.	Stock No.	Description
△vR85	46681300	10Ω 1/4W F.R.
vC81	46929100	100μF 16V E.C.
vC84	46656400	2200pF 100V F.C.
vFL50	48363500	Trap Coil
vL1	46090500	Inductor 2.7mH
vL80	48525100	OSC Coil OF-10
vVR1	48078800	2.2kΩ S.V.R., P.B Level adj.
vVR2	48079600	47kΩ S.V.R., REC Level adj.
vVR3	48079600	47kΩ S.V.R., METAL REC Level adj.
vVR50	48079800	100kΩ S.V.R., Bias adj.

8-2. F-5469 Control Switch Board (Stock No. 00992901)

Parts No.	Stock No.	Description
•LED		
nLD1	48189000	GL3HD8, POWER
nLD2	48189100	GL3HY57, PAUSE
nLD3	48189000	GL3HD8, REC
oS1	48113200	Push SW., a-▽
oS2	48113200	Push SW., a-△
oS3	48113200	Push SW., a-▽
oS4	48113200	Push SW., a-STOP
oS5	48113200	Push SW., b-▽
oS6	48113200	Push SW., b-△
oS7	48113200	Push SW., b-▽
oS8	48113200	Push SW., b-STOP
oS9	48113200	Push SW., b-REC
oS10	48113200	Push SW., R-MUTE
oS11	48113200	Push SW., DUBBING
oS12	48158200	Slide SW., DOLBY NR
oS13	48158200	Slide SW., DUBBING SPEED
•Transistor		
wQ15	46367101	2SC2603
	or 48058801	2SC1740S
wQ16	46367101	2SC2603
	or 48058801	2SC1740S
•Diode		
wD9	03117600	1S2473T77
	or 46086000	1S1588TP-3
wD10	03117600	1S2473T77
	or 46086000	1S1588TP-3
wD11	03117600	1S2473T77
	or 46086000	1S1588TP-3
wD12	03117600	1S2473T77
	or 46086000	1S1588TP-3
wD13	03117600	1S2473T77
	or 46086000	1S1588TP-3
wD14	03117600	1S2473T77
	or 46086000	1S1588TP-3
wD15	03117600	1S2473T77
	or 46086000	1S1588TP-3
wD16	03117600	1S2473T77
	or 46086000	1S1588TP-3

8-3. F-4916 Fuse Board

Parts No.	Stock No.	Description
△mF1	07184700	AC Fuse, 1.0A <EU, BS, AS>
△mF2	07184200	AC Fuse, 315 mA <EU, BS, AS>

8-4. F-5397 a-side PLAY BACK Amp. Board
(Stock No. 00993301)

Parts No.	Stock No.	Description
•Transistor		
vQ501	46367101	2SC2603
	or 48058801	2SC1740S
vQ502	46367101	2SC2603
	or 48058801	2SC1740S
vQ503	46367101	2SC2603
	or 48058801	2SC1740S
•FET		
vFT501	46643800	2SJ103-Y
	or 46643801	2SJ103-GR
vFT502	46643800	2SJ103-Y
	or 46643801	2SJ103-GR
•IC		
vIC501	46638700	M5220P
vIC502	46673800	M5218P
vVR501	48078300	330Ω S.V.R., Pre P.B. Level adj.

8-5. F-5336 Noise Reduction Board (Stock No. 00954801)

Parts No.	Stock No.	Description
•Transistor		
xQ1	46367101	2SC2603
	or 46367301	2SC2458
	or 48058801	2SC1740S
xQ2	46367101	2SC2603
	or 46367301	2SC2458
	or 48058801	2SC1740S
xQ105	46367101	2SC2603
	or 46367301	2SC2458
	or 48058801	2SC1740S
•IC		
xIC1	46128200	TA7629P
xIC2	07224800	TC4066BP
	or 46421000	μPD4066BC
	or 48054500	MSM4066BRS
	or 48063800	BU4066B
xJW1	46741100	Cross Conductor (Chip)
xJW2	46741100	Cross Conductor (Chip)
xJW3	46741100	Cross Conductor (Chip)
xJW4	46741100	Cross Conductor (Chip)
xJW6	46741100	Cross Conductor (Chip)
xJW7	46741100	Cross Conductor (Chip)
xJW8	46741100	Cross Conductor (Chip)
xJW9	46741100	Cross Conductor (Chip)
xJW10	46741100	Cross Conductor (Chip)
xJW11	46741100	Cross Conductor (Chip)
xR1	46753200	220kΩ 1/8W Chip R.
xR2	46748200	1.8kΩ 1/8W Chip R.
xR4	46747200	680Ω 1/8W Chip R.
xR5	46752400	100kΩ 1/8W Chip R.
xR6	46745800	180Ω 1/8W Chip R.
xR7	46748800	3.3kΩ 1/8W Chip R.
xR8	46751600	47kΩ 1/8W Chip R.
xR9	46752800	150kΩ 1/8W Chip R.
xR10	46753400	270kΩ 1/8W Chip R.
xR11	46750000	10kΩ 1/8W Chip R.
xR12	46754800	1MΩ 1/8W Chip R.
xR13	46751600	47kΩ 1/8W Chip R.
xR100	46748000	1.5kΩ 1/8W Chip R.
xR101	46741100	Cross Conductor (Chip)
xR102	46754800	1MΩ 1/8W Chip R.
xR109	46750000	10kΩ 1/8W Chip R.
xR110	46751600	47kΩ 1/8W Chip R.
xFL1	48363600	DOLBY Filter
xVR1	46633700	1kΩ (B) S.V.R., P.B. Level adj.
	or 48199300	1kΩ (B) S.V.R., P.B. Level adj.

8-6. F-5468 Logic Control Board (Stock No. 00992801)

Parts No.	Stock No.	Description
•Transistor		
wQ1	46367101	2SC2603
	or 48058801	2SC1740S
wQ2	46719900	DTC124ES
wQ3	46367001	2SA1115
	or 48058601	2SA933S
wQ4	46367101	2SC2603
	or 48058801	2SC1740S
wQ5	46367101	2SC2603
	or 48058801	2SC1740S
wQ6	46719900	DTC124ES
wQ7	46614101	2SC3243
wQ8	46367101	2SC2603
	or 48058801	2SC1740S
wQ9	46359801	2SC2001
	or 48000901	2SC2060
wQ10	46367101	2SC2603
	or 48058801	2SC1740S
wQ11	46359701	2SA952
	or 48000801	2SA934
wQ12	46614101	2SC3243
wQ13	46367101	2SC2603
	or 48058801	2SC1740S
wQ14	46359801	2SC2001
	or 48000901	2SC2060
•IC		
wIC1	48313600	TC9312N-025
wIC2	46443800	μPD4001BC
	or 48050000	MSM4001BRS
	or 48067200	BU4001B
wIC3	46149600	BA6208
wIC4	46149600	BA6208
•Diode		
wD1	03117600	1S2473T77
	or 46086000	1S1588TP-3
wD2	03117600	1S2473T77
	or 46086000	1S1588TP-3
wD3	03117600	1S2473T77
	or 46086000	1S1588TP-3
wD4	03117600	1S2473T77
	or 46086000	1S1588TP-3
wD5	03117600	1S2473T77
	or 46086000	1S1588TP-3
wD6	03117600	1S2473T77
	or 46086000	1S1588TP-3
wD7	48123600	11E2
wD8	48123600	11E2
wD21	46464000	MC921 (Chip)
•Zener Diode		
wDZ1	46110800	05Z4.7-X
	or 46110900	05Z4.7-Y
wDZ2	46110800	05Z4.7-X
	or 46110900	05Z4.7-Y
wDZ3	46111800	05Z6.2-Y
	or 46825300	RD6.2E-B2
wDZ4	46111800	05Z6.2-Y
	or 46825300	RD6.2E-B2
ΔwR22	46228300	27Ω 1/2W N.I.R.
ΔwR29	46624200	82Ω 2W N.I.R.
ΔwR32	46228300	27Ω 1/2W N.I.R.
ΔwR39	46624200	82Ω 2W N.I.R.
wC2	46695200	0.01μF 50V F.C.
wC4	46284100	0.1μF 50V F.C.
wC6	46284100	0.1μF 50V F.C.

8-7. F-5467 Signal Switch & Power Supply Board (Stock No. 00992701)

Parts No.	Stock No.	Description
•Transistor		
mQ1	48150101	2SD1406
	or 48509401	2SD1761
mQ2	46367001	2SA1115
	or 48058601	2SA933S
mQ3	46367001	2SA1115
	or 48058601	2SA933S
•IC		
△mIC1	46361400	L78N10
△mIC2	46359400	L78N05
•Diode		
△mD1	03117700	10E-2
△mD2	03117700	10E-2
△mD3	03117700	10E-2
△mD4	03117700	10E-2
△mD5	48123600	11E2
△mD6	48123600	11E2
△mD7	48123600	11E2
△mD8	48123600	11E2
mD9	03117600	1S2473T77
	or 46086000	1S1588TP-3
mD10	03117600	1S2473T77
	or 46086000	1S1588TP-3
mD11	03117600	1S2473T77
	or 46086000	1S1588TP-3
mD12	03117600	1S2473T77
	or 46086000	1S1588TP-3
•Zener Diode		
mDZ1	46113800	05Z12-X
	or 46113900	05Z12-Y
	or 46114000	05Z12-Z
mDZ2	46111400	05Z5.6-X
	or 46111500	05Z5.6-Y
mDZ3	46112600	05Z8.2-X
	or 46112700	05Z8.2-Y
	or 46112800	05Z8.2-Z
mC6	48103700	4.7μF 50V E.B.
oJ2	46547200	Jack, Compu-Selector
oJ1	46371500	4P Terminal, LINE IN/OUT
△pS1	48172700	Push SW., POWER
•Transistor		
vQ31	46367101	2SC2603
	or 48058801	2SC1740S
vQ32	48223100	DTC114TS
vQ33	46719800	DTA124ES
vQ34	46367101	2SC2603
	or 48058801	2SC1740S
vQ35	46367101	2SC2603
	or 48058801	2SC1740S
vQ36	48223100	DTC114TS
vQ37	46367101	2SC2603
	or 48058801	2SC1740S
vQ38	46367101	2SC2603
	or 48058801	2SC1740S
vQ39	46367101	2SC2603
	or 48058801	2SC1740S
vQ40	46367101	2SC2603
	or 48058801	2SC1740S
vQ41	46367101	2SC2603
	or 48058801	2SC1740S
vQ42	46367101	2SC2603
	or 48058801	2SC1740S
•IC		
vIC31	07224800	TC4066BP
	or 46421000	μPD4066BC
	or 48054500	MSM4066BRS
	or 48063800	BU4066B
vIC32	46545800	TC4053BP
	or 48353000	BU4053B
	or 48353100	μPD4053BC

Parts No.	Stock No.	Description
•Diode		
vD31	03117600	1S2473T77
	or 46086000	1S1588TP-3
vD32	03117600	1S2473T77
	or 46086000	1S1588TP-3
vD33	03117600	1S2473T77
	or 46086000	1S1588TP-3
vD34	03117600	1S2473T77
	or 46086000	1S1588TP-3
•Transistor		
wQ17	46719900	DTC124ES
wQ18	46719900	DTC124ES
•Diode		
wD17	03117600	1S2473T77
	or 46086000	1S1588TP-3
wD18	03117600	1S2473T77
	or 46086000	1S1588TP-3
wD19	03117600	1S2473T77
	or 46086000	1S1588TP-3
wD20	03117600	1S2473T77
	or 46086000	1S1588TP-3

8-8. F-4729 Speed Control Board

Parts No.	Stock No.	Description
•Transistor		
tQ1	07206901	2SC2001
•Diode		
tD1	03111600	1S2473D
tVR1	46839500	4.7kΩ S.V.R., Normal Speed
tVR2	46839600	10kΩ S.V.R., High Speed
tS1	47292710	Leaf SW., half sensor
tS2	47292710	Leaf SW., prevention tab sensor <b-side Mechanism>
tS3	47292710	Leaf SW., HIGH
tS4	47292710	Leaf SW., METAL <b-side Mechanism>

8-9. F-5470 Power STAND-BY Indicator Board

Parts No.	Stock No.	Description
•LED		
nLD4	46858300	GL-1HD201 <EU, BS, AS>

10. SCHEMATIC DIAGRAM 10-1. Amplifier Section

* Design and specifications subject to change without notice for improvement.
 * La présentation et les spécifications sont susceptibles d'être modifiées sans préavis par suites d'améliorations éventuelles.
 * Änderungen, die dem technischen Fortschritt dienen, bleiben vorbehalten.

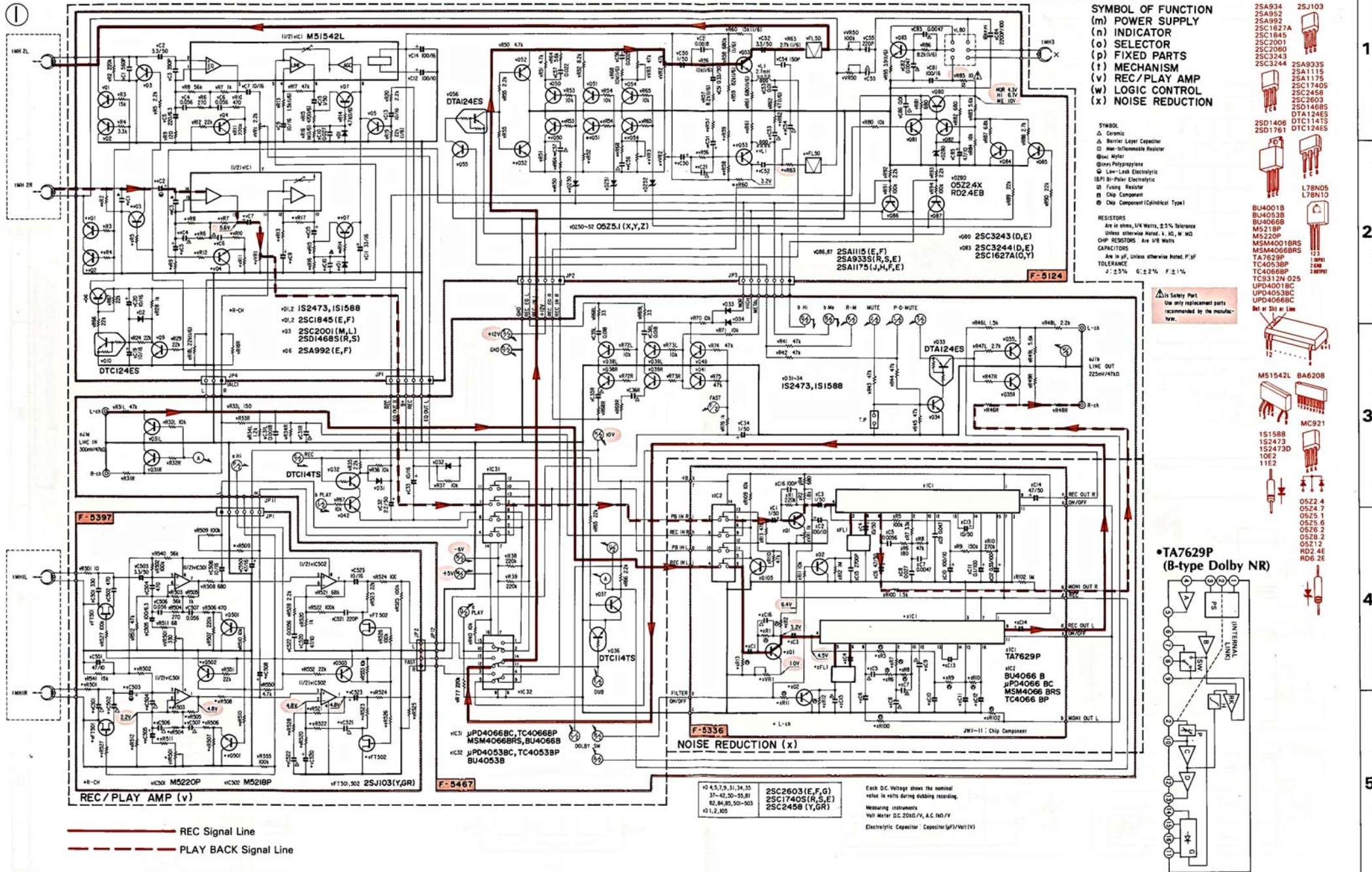

10-2. Control Section

* Design and specifications subject to change without notice for improvement.
 * La présentation et les spécifications sont susceptibles d'être modifiées sans préavis par suites d'améliorations éventuelles.
 * Änderungen, die dem technischen Fortschritt dienen, bleiben vorbehalten.

②

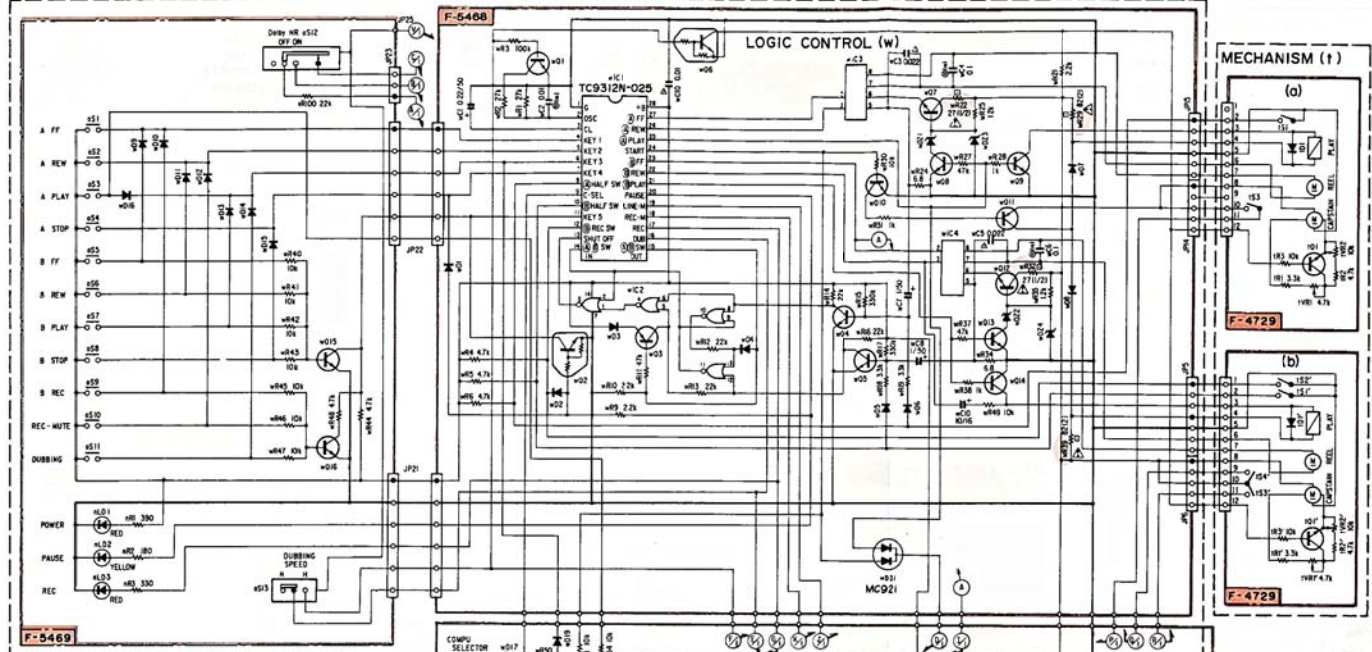

OPTIONAL USE OF SEMICONDUCTORS

#01,2,3,4	10E2
#05,6,7,8	11E2
#1,8	
#09,10,11,12	IS2473
#1,2,3,4	
1,5,6,8,10	
11,12,13,14	
15,16,17,18	
19,20	
#01	IS1588
#02,1	05212 X,Y,Z
#02,2	0525.6 X,Y
#02,3	0528.2 X,Y,Z
#01,2	0524.7 X,Y
#01,4	0526.2Y RD62EB2
#C2	BU4001B μPD4001BC MSM4001BRS
#C3,4	BA6208
#D3,3	GL-3HD7
#D2	GL-3HY57
#D4	GL-1HD201
#D1	2SC3851 O,Y 2SD1406 O,Y,GR 2SD1761 D,E,F
#D2,3	2SA1115 E,F 2SA933S R,S,E 2SA1175 J,H,F,E
#01,4,5,8,10	2SC2603 E,F,G 2SC1740S R,S,E 2SC2458 Y,GR
15,16,18	DTC124ES
#01,2	2SC3243 D,E
#09,14	2SC2001 M,L 2SC2060 P,Q,R
#01,1	2SA952 M,L 2SA934 P,Q,R
#01	2SC2001 M,L

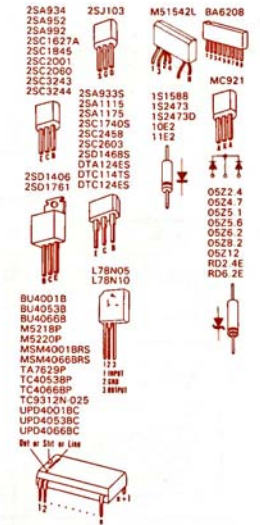

W: EUROPE, UNITED KINGDOM, AUSTRALIA
 Model only

•BU4053B, μPD4053BC, TC4053BP
 (Triple 2-Channel Analog Multiplexer)

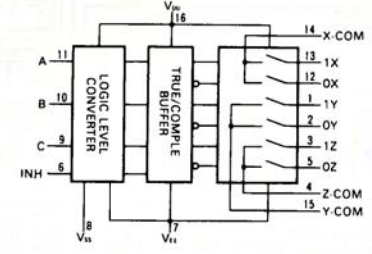

•Truth Table <TC4053BP>

CONTROL INPUT				"ON" CHANNEL
INHBIT	C	B	A	
L	L	L	L	0X, 0Y, 0Z
L	L	L	H	1X, 0Y, 0Z
L	L	H	L	0X, 1Y, 0Z
L	L	H	H	1X, 1Y, 0Z
L	H	L	L	0X, 0Y, 1Z
L	H	L	H	1X, 0Y, 1Z
L	H	H	L	0X, 1Y, 1Z
L	H	H	H	1X, 1Y, 1Z
H	X	X	X	NONE

X = Don't Care

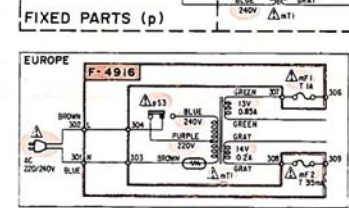
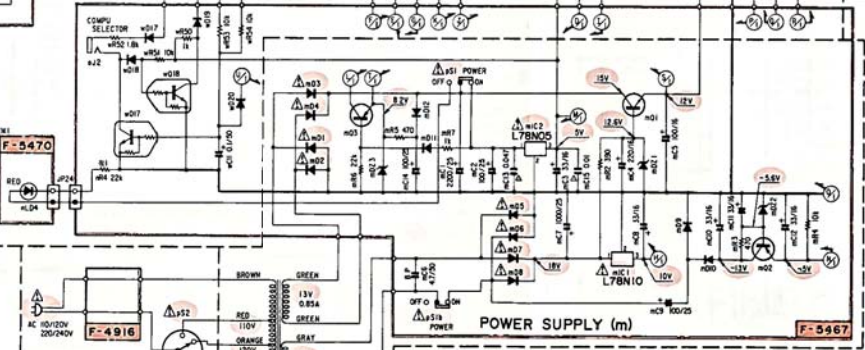
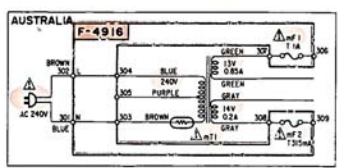
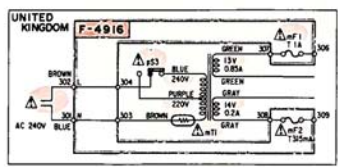
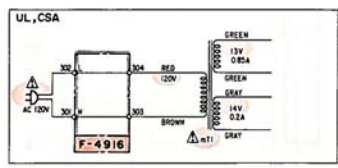

•BA6208 (Motor Drive)

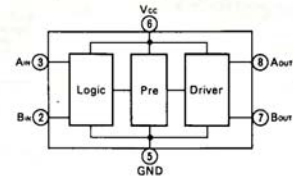

10. TIMING CHART OF CONTROL IC, TC9312N-025

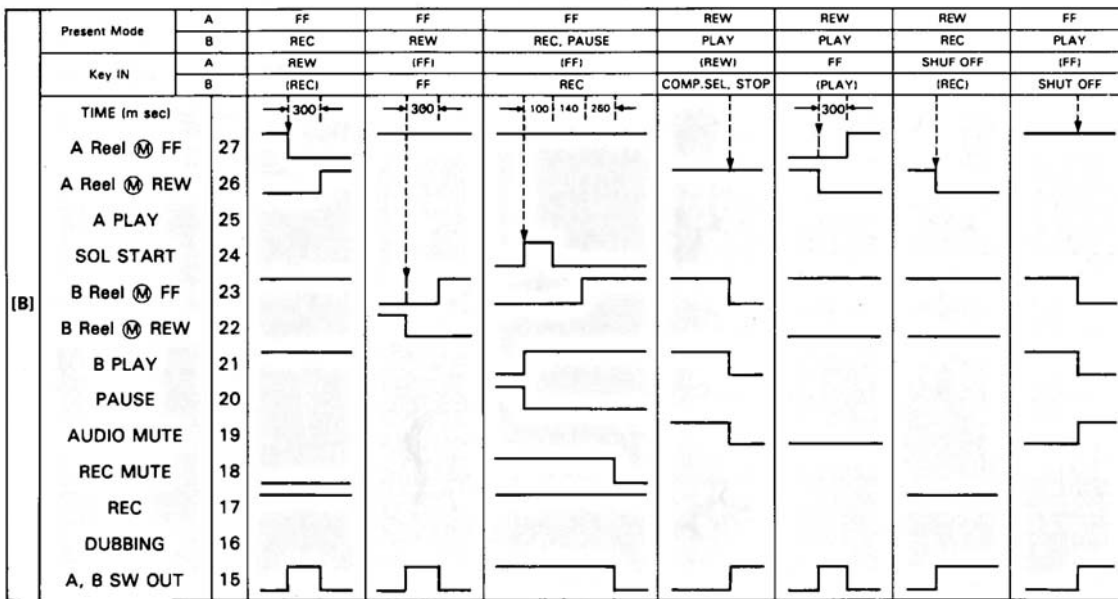
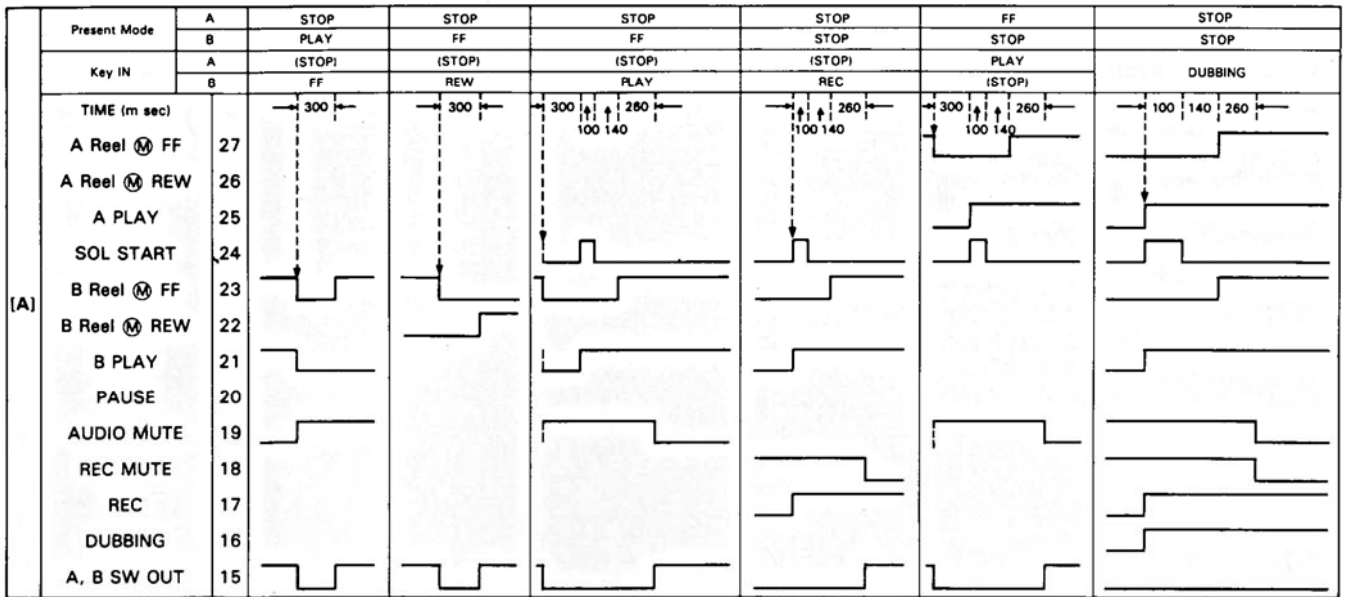

•Pin Connection of TC9312N-025

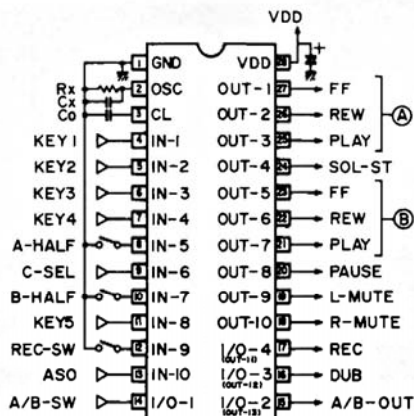

•Input Relation of Control IC, TC9312-025

TACT SW INPUT	IC INPUT				KEY 5		
	KEY 1	KEY 2	KEY 3	KEY 4	H (5.0V)	M (2.5V)	L (0V)
(A)FF	○			○			
(A)REW		○		○			
(A)PLAY			○	○			
(A)STOP				○	○		
(B)FF	○						○
(B)REW		○					○
(B)PLAY			○				○
(B)STOP				○			○
(B)REC	○					○	
(B)REC MUTE		○				○	
DUBBING			○			○	

12. PACKING LIST

Parts No.	Stock No.	Description
1	47859900	Vinyl Bag
2	47764620	Styrofoam Packing
3	27217000	Carton Case

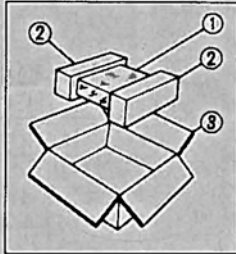

13. ACCESSORY LIST

Stock No.	Description
46118600	PJP Cord
or 38103200	PJP Cord
48181300	Mini Plug Cord
49012600	Operating Instruction (*E·F·S)
49012700	Operating Instruction (*G·I·Sw)

***Note:**

E·F·S: English·French and Spanish Version

G·I·Sw: German·Italian and Swedish Version

SANSUI ELECTRIC CO., LTD.:

SANSUI ELECTRONICS CORPORATION:

SANSUI ELECTRONICS (U.K.) LTD.:

SANSUI ELECTRONICS G.M.B.H.:

14-1, Izumi 2-chome, Suginami-ku, Tokyo 168 Japan
 PHONE: (03) 324-8891/TELEX: 232-2076 (International Division)
 1250 Valley Brook Ave. Lyndhurst, N.J. 07071 U.S.A.
 17150 South Margay Ave. Carson, California 90746 U.S.A.
 3036 Kospaka Street, Honolulu, Hawaii 96819 U.S.A.

Unit 10A, Lyon Industrial Estate, Rockware Avenue, Greenford, Middx UB6, OAA, England
 Pau Ehrich Strasse 8, 6074 Rödermark 2, West Germany

(SM1-314)

Printed in Japan (1986.7M) <Stock No. 36524100>