

SERVICE MANUAL

AUTO REVERSE CASSETTE DECK

SANSUI D-77R

(Silver & Black Model)

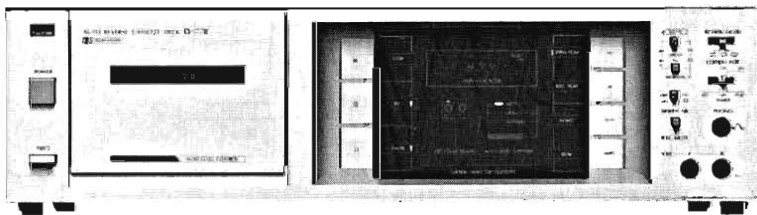

● SPECIFICATIONS

Track	4-Track (2-Channel Stereo)
Tape Speed	4.8 cm/sec. (1-7/8 ips)
Heads (2-head configuration)	
Rec/P.B head	HIGH-Bs hard permalloy
Erase head	Double-gap HIGH-Bs ferrite
Motor	Capstan: Electronically Controlled DC Motor Reels: DC Motor
Wow and flutter	within 0.05 % WRMS
Fast wind time	approximately 80 seconds (C-60)
Frequency response (-20 VU recording/playback)	
Normal Tape (LH)	20 to 15,000 Hz (30 to 14,000 Hz \pm 3 dB)
Chrome Tape	20 to 17,000 Hz (30 to 16,000 Hz \pm 3 dB)
Metal Tape	20 to 18,000 Hz (30 to 17,000 Hz \pm 3 dB)
Signal to noise ratio (Record/Playback)	
Metal Tape (without Dolby Noise Reduction Effect)	better than 58 dB (weighted)
(With Dolby Noise Reduction)	better than 68 dB (above 5 kHz)
Erasure factor (Metal Tape)	more than 70 dB at 1,000 Hz
Input sensitivity and impedance (0 VU, 1,000 Hz)	
MIC	0.4 mV/200 Ω ~ 5 k Ω
LINE IN (REC)	150 mV/47 k Ω
Output level (0 VU, 1,000 Hz)	
LINE OUT (PLAY)	240 mV
Power requirements	
Power voltage	120/220/240 V (50/60 Hz) For U.S.A. and Canada
Power consumption	120 V (60 Hz) 15 W
Dimensions	430 mm (16-15/16") W 118 mm (4-11/16") H 223 mm (8-13/16") D
Weight	4.0 kg (8.8 lbs.) net 4.8 kg (10.6 lbs.) packed

* Design and specifications subject to changes without notice for improvements.

* The word "Dolby" is a trademark of Dolby Laboratories. This product is manufactured under the license from Dolby Laboratories.

Sansui

SANSUI ELECTRIC CO., LTD.

1. BLOCK DIAGRAM

1-1. Recording Operation

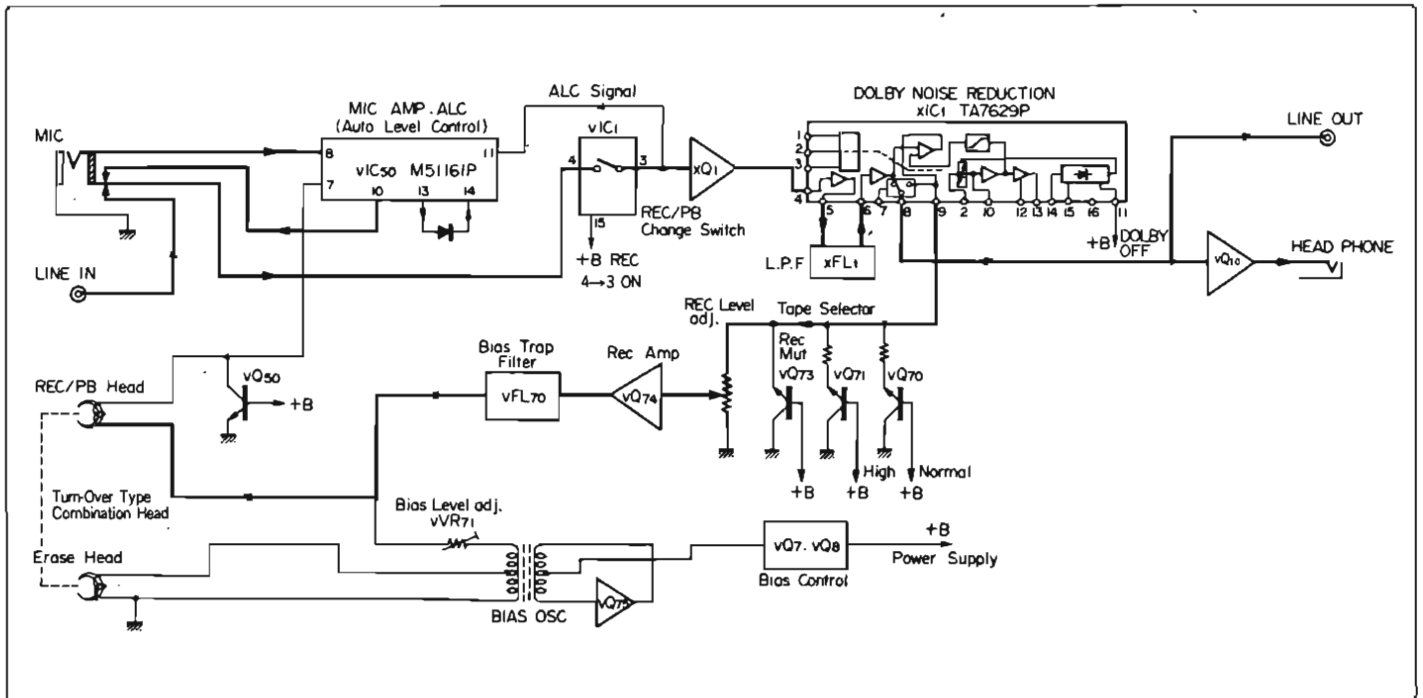

1-2. Playback Operation

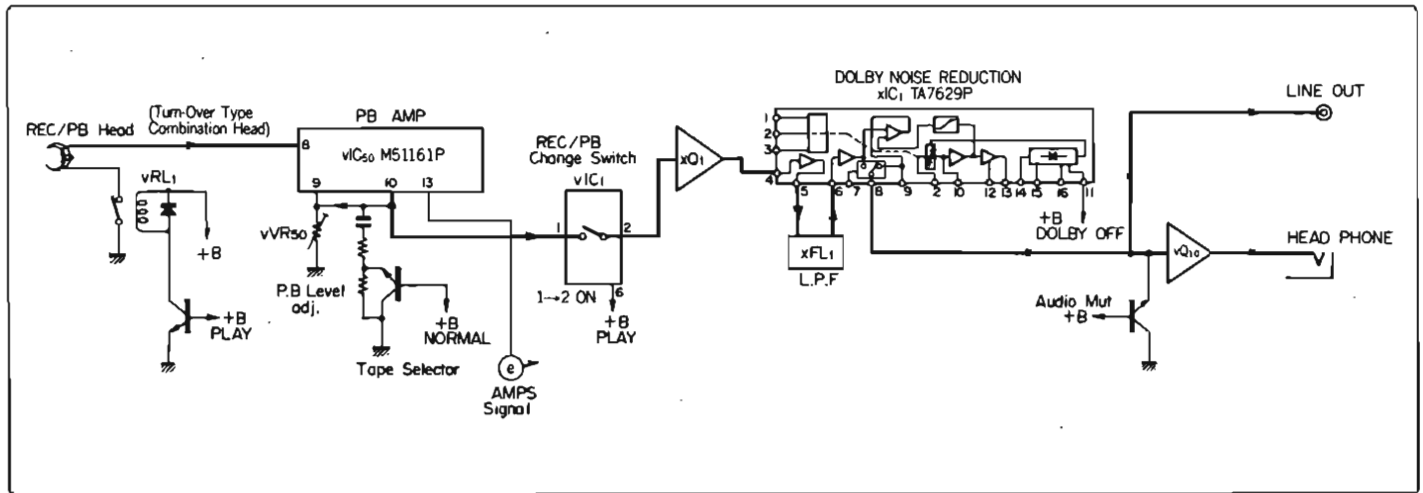

1-3. Logic Control Operation

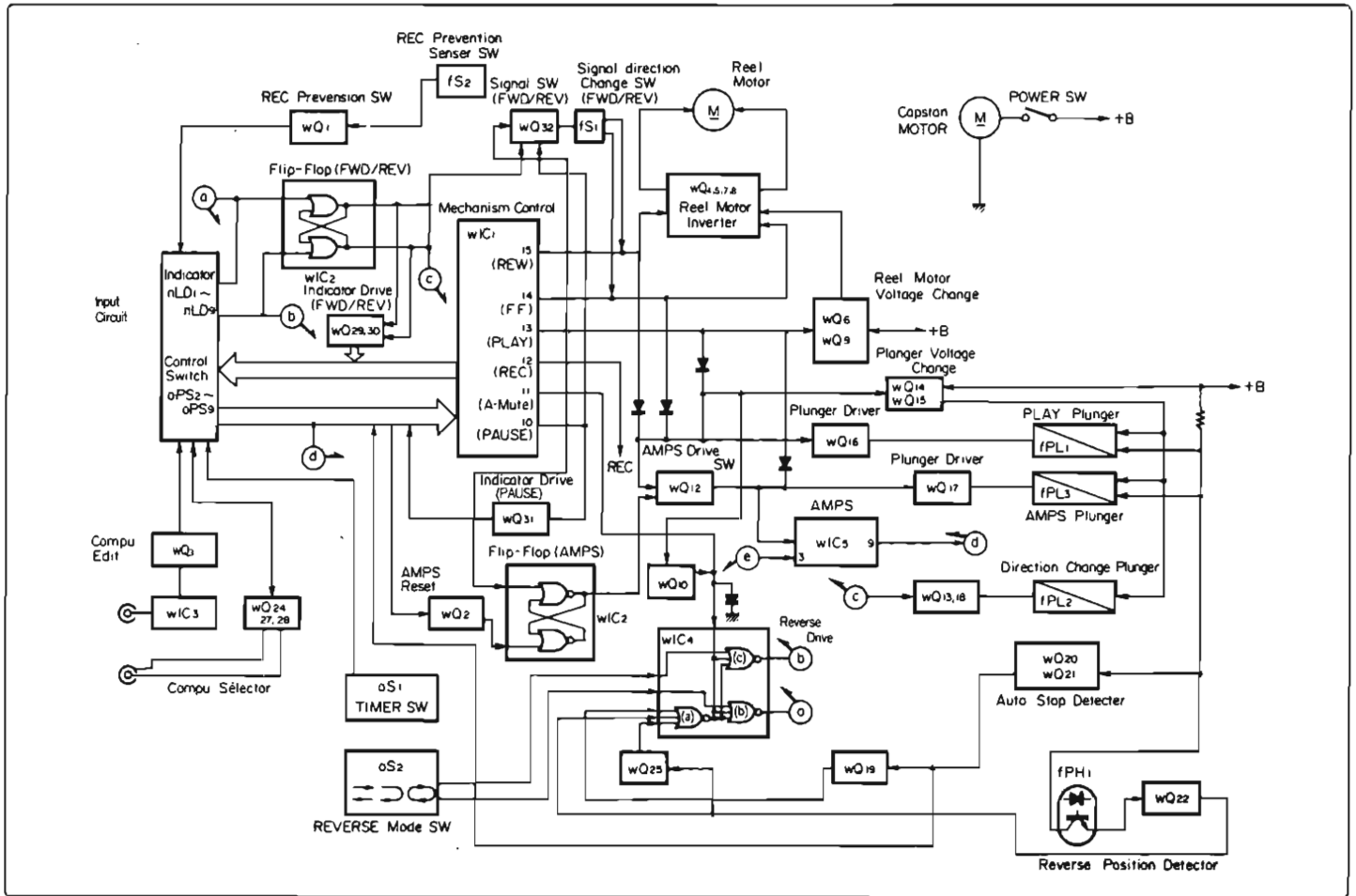

2. TRANSISTOR & IC CONDITION OF LOGIC CONTROL CIRCUIT

2-1. Main Operation Mode

• See Input/Output Table of TC9143P on Page 3 and Schematic Diagram on Page 13, 14.

MODE	Parts No.		wQ																															
	2	4	5	7	8	9	10	11	12	13	14	15	16	17	29	30	31	32																
FWD·PLAY(REC)	○	○			○	○	●				●	●	○				○		○															
REV·PLAY(REC)	○		○	○		○	●			○	●	●	○						○															
FF	○	○			○		●				●	●		○																				
AMPS·FF	○	○			○		●		○		●	●	○	○																				
REW	○		○	○			●				●	●		○																				
AMPS·REW	○		○	○			●		○		●	●	○	○																				
PAUSE	○							○											○															
STOP																																		

○ ON
● ON (During the time determined by a time constant of capacitor and resistor)

- wQ1: Rec Prevention Switch
- wQ3: PAUSE Switch for Compu Edit. (When the muting signal from the turntable is applied to COMPU EDIT. Terminal, wQ3 is turned ON.)
- wQ6: Reel Motor voltage change (When operation mode is FF, REW, AMPS FF or AMPS REW, Emitter voltage of the transistor change to H-voltage level.)
- (wQ20: Current Detector for Auto Stop
- wQ21: Reset Switch for IC TC-9143 (When Power Switch is pushed, wQ23 is turned ON during the time determined by a time constant of capacitor and resistor, therefore Input pin No. 6 of the control IC is kept at a L-voltage level.)

- wQ24: Stop Switch for COMPU SELECTOR (When the PHONO or TUNER button of Amplifier <Receiver> is pushed during tape play back, wQ24 is turned ON, to stop the Cassette Deck automatically.)
- wQ26: TIMER operation driver (When TIMER operation is performed, wQ26 is turned ON during the time determined by a time constant of capacitor and resistor.)
- wQ27: Start Switch for COMPU SELECTOR (When the TAPE-1 button of Amplifier <Receiver> is pushed, wQ27 is turned ON, the Cassette Deck starts automatically to play back a tape.)
- wQ28: Prevention Switch for COMPU SELECTOR (wQ28 is not turned ON when the mode is REC/PLAY, therefore Input selector of amplifier <Receiver> is not set to the TAPE-1.)

2-2. Auto Reverse Operation Mode

REVERSE MODE	Auto Derection Change	Parts No. Pin No.	wIC4(a)				wIC4(c)				wIC4(b)				wQ 19	wQ 22	wQ 25
			IN		OUT		IN		OUT		IN		OUT				
			3	4	5	6	1	2	8	9	11	12	13	10			
D	FWD PLAY → REV PLAY		L	L	H	L	L	L	L	H	H	L	L	L		●	○
	REV PLAY → FWD PLAY		L	H	L	L	L	L	H	L	L	L	L	H	○	-	-
U	FWD REC or PLAY → REV REC or PLAY		L	L	H	L	L	L	L	H	H	L	L	L		●	○

○ OFF
● ON
H High Level
L Low Level

3. INTERIOR BLOCK DIAGRAM OF IC

● M51161P (MIC Amp. & PLAY EQ. Amp)

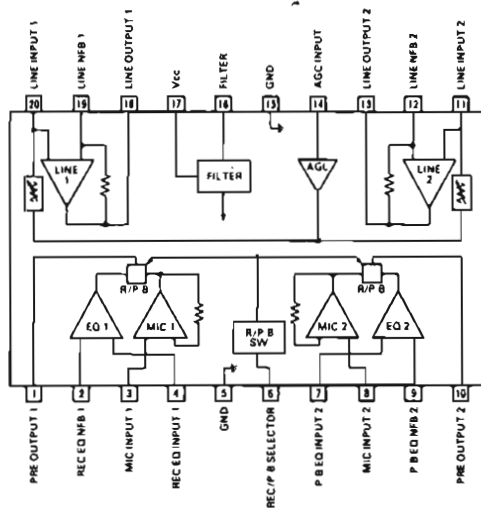

● TC9143P (Logic Control)

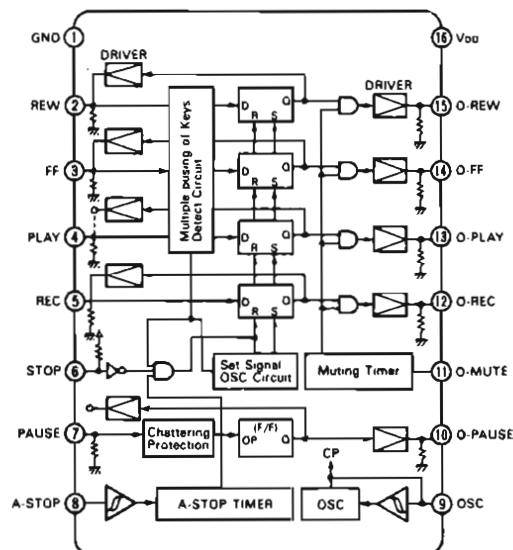

● TA7341P (Automatic Music Search)

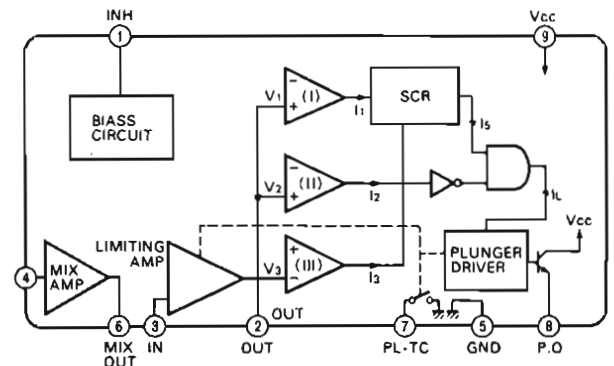

● TA7629P (B-type NOISE REDUCTION)

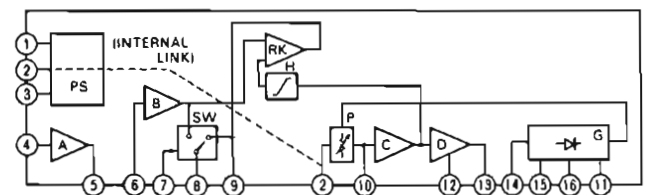

● Input/Output Table of TC-9143P (The "o" marks denote H-Level Output)

KEY INPUT	OUTPUT	O-FF	O-REW	O-PLAY	O-REC	O-MUTE	O-PAUSE
STOP						○	
FF		○				○	
REW			○			○	
PLAY				○			
REC					○		
REC/PLAY				○	○		
P A U S E	STOP					○	○
	PLAY			○		○	○
	REC				○	○	○
	REC/PLAY			○	○	○	○
A-STOP						○	

4. ADJUSTMENTS

4-1. Tape Speed Adjustment

- Note: 1. Use Sansui Test Tape, SCT-S3K.
(3 kHz signal is recorded on the tape).
2. Connections are shown in Fig. 4-1.

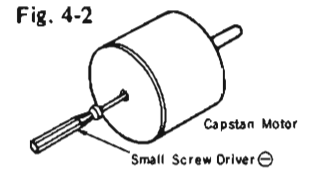
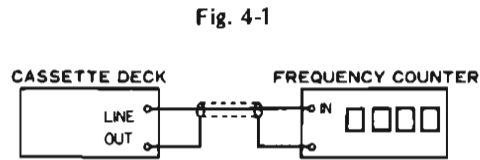

STEP	SUBJECT	MEASURE OUTPUT	SETTING	ADJUSTMENT	ADJUST FOR	REMARKS
1.	TAPE SPEED Adj.	LINE OUT Frequency counter	Playback (FWD) the TEST TAPE SCT-S3K.	Turn semi-variable resistor as Fig. 4-2.	3000Hz \pm 45Hz	Use small screw driver.

4-2. Playback Adjustment

- Note: 1. Before this adjustment, clean REC/P.B. head surface.
2. For this adjustment, use Sansui Test Tape, SCT-F10K, SCT-L400N and SCT-F1K.
3. Set the Dolby NR switch to be OFF.
4. Connections are shown in Fig. 4-3.

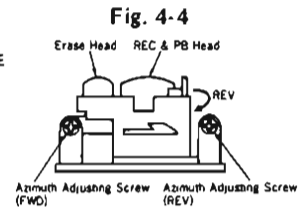
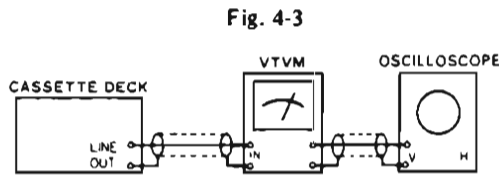

STEP	SUBJECT	MEASURE OUTPUT	SETTING	ADJUSTMENT	ADJUST FOR	REMARKS
1.	REC/P.B. Head Adj.	LINE OUT VTVM and Scope	Playback the TEST TAPE SCT-F10K	Adjust the azimuth adjusting screw in Fig. 4-4.	Maximum output from L and R-ch on both FWD and REV PLAY.	Refer to removal of Lid After this adjustment, lock the screw with paint.
2.	Playback Level Adj.	Same as above	Set TAPE SELECTOR to NORMAL (LH) position. Playback the TEST TAPE SCT-L400	Adjust vVR50 of L-CH and R-CH on both FWD and REV PLAY.	320mV \pm 2dB	See Top View on page 10.
3.	High Frequency Equalization Check	Same as above	Set TAPE SELECTOR to NORMAL (LH) position. Playback (FWD) the TEST TAPE SCT-F1K.	—	—	Read output levels on both channels.
			Playback (FWD) the TEST TAPE SCT-F10K	—	—	Confirm that the output levels are within \pm 3 dB comparing with the above readings.

Note: On STEP 3, set the TAPE SELECTOR to HIGH (CrO₂) position during playback of SCT-10K, and confirm the indication on VTVM drops approximately 4.5 dB.

4-3. Recording Adjustment

1) Bias Adjustment

- * This adjustment is required when replacing bias osc circuit, variable resistor for bias adjustment or REC/PB head.
Note: 1. For this adjustment, use Sansui Test Tape, SCT-SA.
2. Set the Dolby NR Switch to be OFF.
3. Connections are shown in Fig. 4-5.

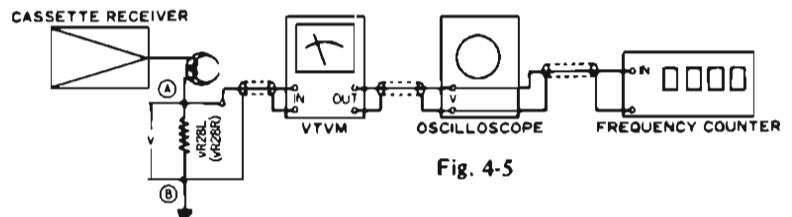

STEP	SUBJECT	MEASURE OUTPUT	SETTING	ADJUSTMENT	ADJUST FOR	REMARKS
1.	Recording Bias Adj.	Between (A) & (B) points vVR28L & vR28R. VTVM, Scope, Frequency Counter	Load the TEST TAPE SCT-SA. Depress PAUSE, REC and FWD PLAY buttons. Set TAPE SELECTOR to HIGH (CrO ₂) position.	Adjust kVR1L for L-CH and kVR1R for R-CH.	4.6mV	See Top View on page 10.
			Set TAPE SELECTOR to NORMAL (LH) position.	—	—	Confirm the indication on VTVM shows 3.6mV.
			Set TAPE SELECTOR to METAL position.	—	—	Confirm the indication on VTVM shows 8.8mV.

2) REC Level & Frequency Response Adjustment

- Note: 1. Connections are shown in Fig. 4-6.
2. Set the Dolby NR switch to be OFF.

Fig. 4-6

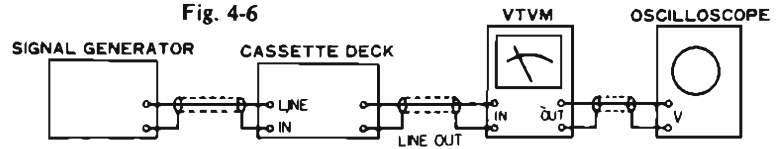

STEP	SUBJECT	INPUT SIGNAL	MEASURE OUTPUT	SETTING	ADJUSTMENT	REMARKS
1.	REC Level Adj.	Feed 1 kHz, 150mV from S.G. into LINE IN.	LINE OUT, VTVM and Scope	Load the TEST TAPE SCT-SA. 1. Depress PAUSE, REC and FWD PLAY button. 2. Adjust the Audio S.G. output level for obtaining 230mV on VTVM. 3. Push off the PAUSE button, then record the 1kHz signal. 4. Play back the 1kHz signal. 5. Confirm that the output levels on both channels are 230mV \pm 2dB on VTVM.	1. If not, turn vVR70 (REC, L-CH, F-3818) and vVR70 (REC, R-CH, F-3818) until output level 230mV \pm 2dB on both channels are obtained.	vVR70 (REC, L-CH), and vVR70 (REC, R-CH) are shown in Top View on page 10.
2.	Frequency Response Adj.	Feed 1kHz 15mV (-20dB) and 10kHz 15mV (-20dB) from S.G. into LINE IN.	Same as above	Load the TEST TAPE SCT-SA. 1. Record (FWD) the 1kHz and 10kHz signals from S.G. 2. Play back (FWD) the 1kHz and 10kHz signals, then confirm that both output levels equal.	1. If not, adjust vVR71L (F-3818) for L-CH and vVR71R (F-3818) for R-CH slightly until the output levels will be equal.	As vVR71L and vVR71R are previously adjusted, turn them slightly, if necessary.

◆ List of Sansui Test Tape

Name of TEST TAPE	Recorded Frequency	Description	Equivalent To
SCT-F40	40 Hz	Playback Frequency Response Check	—
SCT-F1K	1 kHz	High Frequency Equalization Check	—
SCT-F10K	10 kHz	REC/PB Head Adjustment	—
SCT-L400N	400 Hz	Playback Level and Indicator Level Adjustment	—
SCT-S3K	3 kHz	Speed Check and Wow & Flutter Check	—
*SCT-AD NORMAL (LH)	—	Recording Bias Adjustment	TDK AD
*SCT-SA HIGH (CrO ₂)	—	REC/PB Level Adjustment	TDK SA
*SCT-MA (METAL)	—	Frequency Response Check	TDK MA

- Note: Some reference tapes marked * are not supplied.
As these are equivalent to ones indicated above, please obtain these blank tapes on your side as possible.

◆ TAPE SELECTOR Position

NORMAL (LH)		HIGH (CrO ₂)	
FUJI	FL, FXI	FUJI	FX II
MAXELL	UL, UD, XL I, XL I-S	MAXELL	XL II, XL II S
TDK	D, AD, OD	TDK	SA, SA-x
SCOTCH	TARTAN CRYSTAL MASTER 120	SCOTCH	MASTER 70
SONY	AHF, BHF, CHF Low-Noise	SONY	JHF
AGFA	SUPER SUPER COLOR SUPER FERRO DYNAMIC	AGFA	STEREO CHROM
BASF	LN Super LH I	BASF	SCR
METAL			
		MAXELL	MX
		TDK	MA-R, MA
		SCOTCH	Metafine
		SONY	METALLIC

◆ Removement and Attachment of Lid Ass'y

Depress the EJECT button to open the cassette well ass'y, and pull the Lid up and then toward you to remove it as shown in the figure.

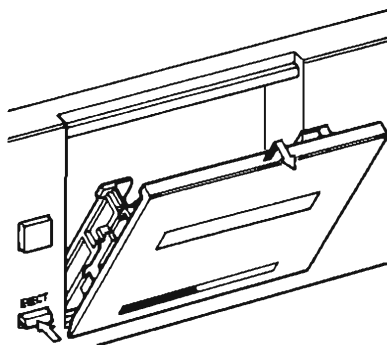

Re-attach the Lid to the cassette holder as shown in the figure.

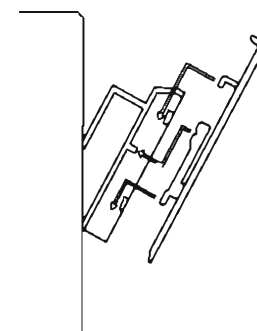

5. PARTS LOCATION & PARTS LIST

5-1. F-3884 Mechanism Control Circuit Board (Stock No. 00711501)

● Since some of capacitors and resistors are omitted from parts lists in this Service Manual, refer to the Common Parts List for capacitors & resistors, which was appended previously to Sansui Manual.

Component Side

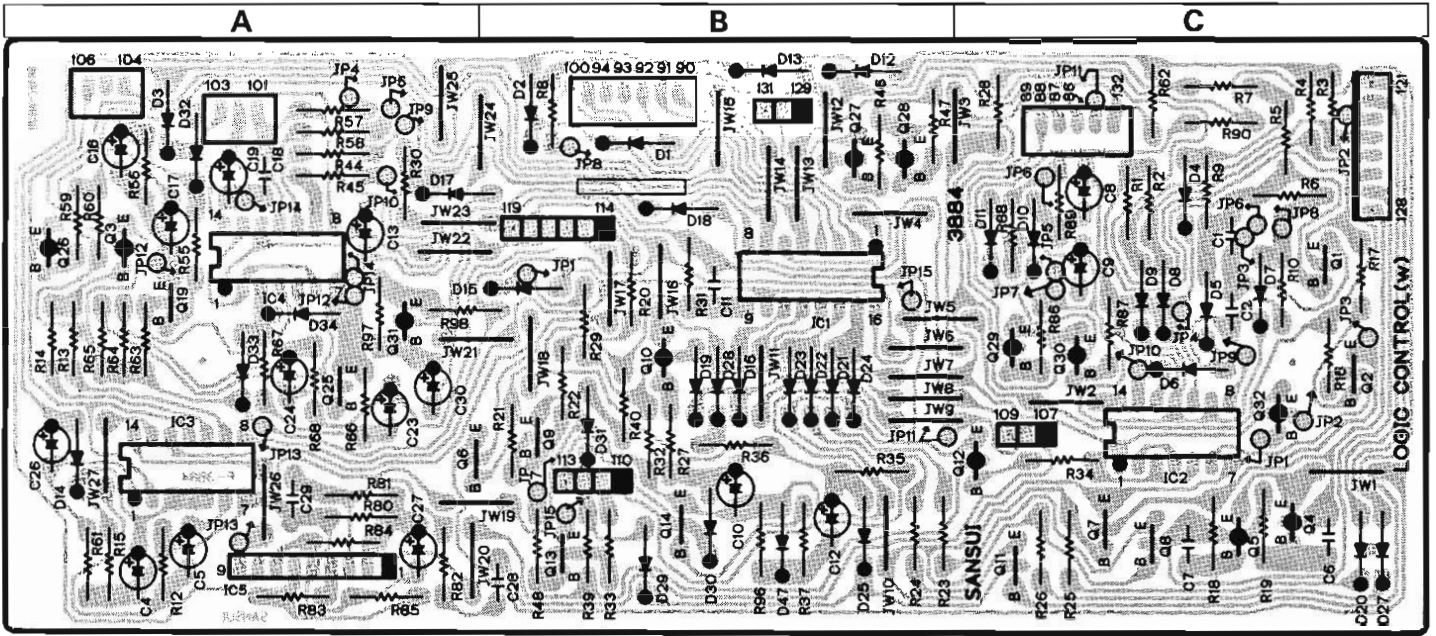

Parts List

Parts No.	Stock No.	Description
● Transistor		
wQ1	46367101	2SC2603
	or 46391901	2SC2785
wQ2	46367101	2SC2603
	or 46391901	2SC2785
wQ3	46367001	2SA1115
	or 46392001	2SA1175
wQ4	46367001	2SA1115
	or 46392001	2SA1175
wQ5	46367001	2SA1115
	or 46392001	2SA1175
wQ6	03085201	2SD438
wQ7	46367101	2SC2603
	or 46391901	2SC2785
wQ8	46367101	2SC2603
	or 46391901	2SC2785
wQ9	46367101	2SC2603
	or 46391901	2SC2785
wQ10	46367001	2SA1115
	or 46392001	2SA1175
wQ11	46367101	2SC2603
	or 46391901	2SC2785
wQ12	46367001	2SA1115
	or 46392001	2SA1175
wQ13	46367001	2SA1115
	or 46392001	2SA1175
wQ14	46367101	2SC2603
	or 46391901	2SC2785
wQ19	46367101	2SC2603
	or 46391901	2SC2785
wQ25	46367101	2SC2603
	or 46391901	2SC2785
wQ26	46367001	2SA1115
	or 46392001	2SA1175
wQ27	46367001	2SA1115
	or 46392001	2SA1175
wQ28	46367001	2SA1115
	or 46392001	2SA1175
wQ29	46367001	2SA1115
	or 46392001	2SA1175
wQ30	46367001	2SA1115
	or 46392001	2SA1175
wQ31	46367001	2SA1115
	or 46392001	2SA1175
wQ32	46367001	2SA1115
	or 46392001	2SA1175

Parts No.	Stock No.	Description
● IC		
wIC1	46406700	TC9143P
wIC2	46443800	μPD4001BC
wIC3	46427100	μPC4023BC
wIC4	46426900	μPD4025BC
	or 46422000	MSM4025RS
wIC5	46422100	TA7341P
● Diode		
wD1 ~ 25	03117600	1S2473D
	or 46086000	1S1588
wD27	03117600	1S2473D
	or 46086000	1S1588
wD28	03117600	1S2473D
	or 46086000	1S1588
wD29	03117600	1S2473D
	or 46086000	1S1588
wD30	03117600	1S2473D
	or 46086000	1S1588
wD31	03117600	1S2473D
	or 46086000	1S1588
wD32	03117600	1S2473D
	or 46086000	1S1588
wD33	03117600	1S2473D
	or 46086000	1S1588
wD34	03117600	1S2473D
	or 46086000	1S1588
wD47	03117600	1S2473D
	or 46086000	1S1588
wD49	03111600	1S2473D
	or 03111800	1S1588
wD50	03111600	1S2473D
	or 03111800	1S1588
wC1	07215800	10000pF 25V C.C.
wC2	07215800	10000pF 25V C.C.
wC6	07215800	10000pF 25V C.C.
wC7	07215800	10000pF 25V C.C.
wC11	07216600	47000pF 25V C.C.
wC24	08451700	1μF 50V E.B.
wC28	07216200	22000pF 25V C.C.
wC29	07214700	1200pF 25V C.C.
wC31	07214000	47000pF 25V C.C.

5-2. F-3879 Main Circuit Board (Stock No. 00710601)

Component Side

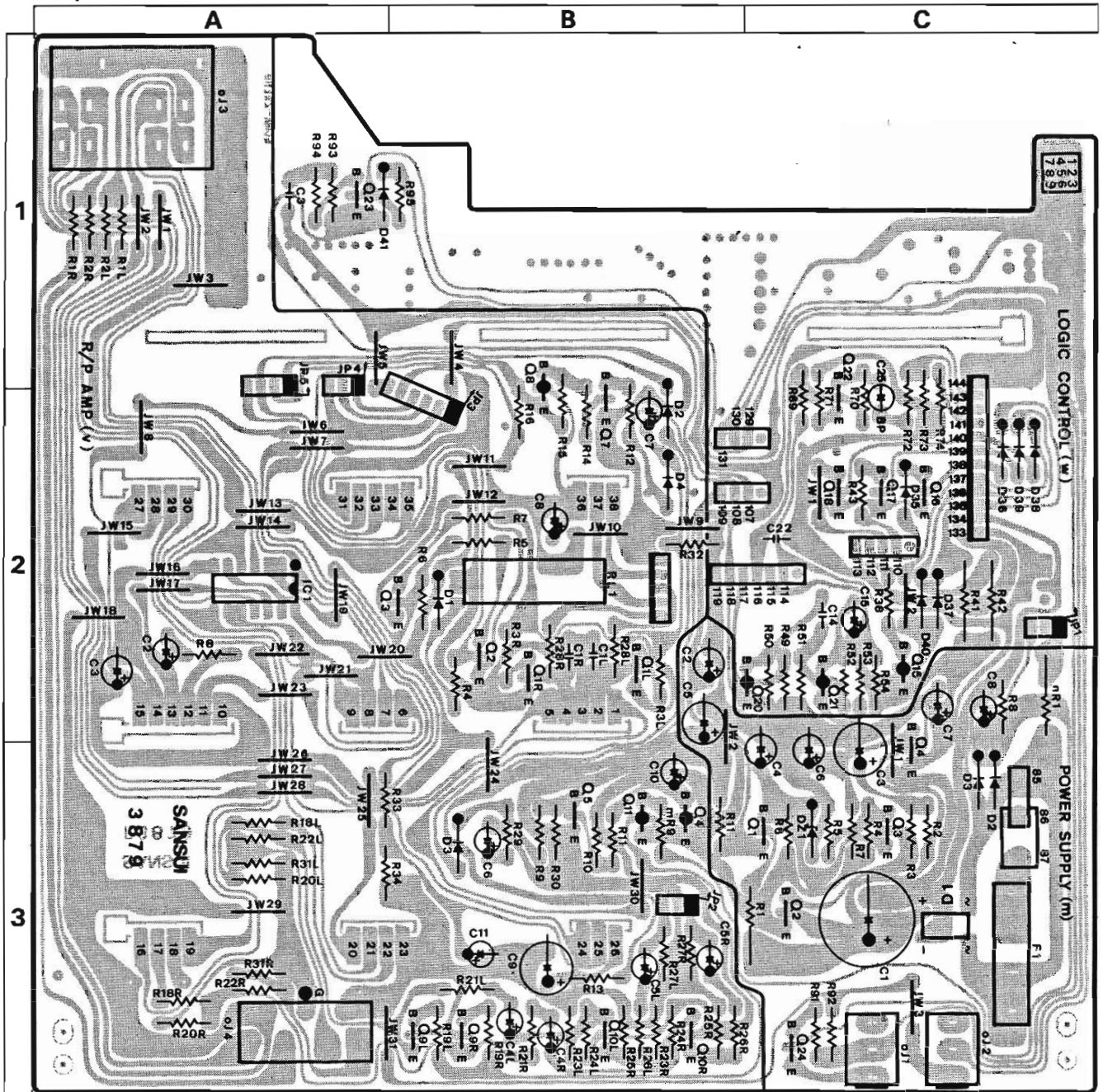

Parts List

Parts No.	Stock No.	Description	Parts No.	Stock No.	Description
●Transistor			●Transistor		
mQ1	03085201	2SD438	vQ1	46367101	2SC2603
mQ3	46367101	2SC2603		or 46391901	2SC2785
	or 46391901	2SC2785	vQ2	46367101	2SC2603
mQ4	03085201	2SD438		or 46391901	2SC2785
●Diode			vQ3	46367101	2SC2603
mD1	46273600	DBB10-B		or 46391901	2SC2785
mD2	03117600	1S2473D	vQ4	46367001	2SA1115
	or 46086000	1S1588		or 46392001	2SA1175
mD3	03117600	1S2473D	vQ5	46367101	2SC2603
	or 46086000	1S1588		or 46391901	2SC2785
●Zener Diode			vQ7	46367101	2SC2603
mDZ1	46111500	05Z5.6-Y		or 46391901	2SC2785
mR1	46228600	47Ω 1/2W N.I.R.	vQ8	46367001	2SA1115
nR1	46228000	15Ω 1/2W N.I.R.		or 46392001	2SA1175
oJ1	46148200	Mini Jack, Compu Selector	vQ9	46367101	2SC2603
oJ2	46148200	Mini Jack, Compu Edit.		or 46391901	2SC2785
oJ3	46212000	Jack, Mic	vQ10	46367101	2SC2603
oJ4	46371500	4P Terminal Board		or 46391901	2SC2785
			vQ11	46367001	2SA1115
				or 46392001	2SA1175
			●IC		
			vic1	46421000	μPD4066BC

Parts List <F-3879>

Parts No.	Stock No.	Description
●Diode		
vD1	03117600	1S2473D
	or 46086000	1S1588
vD2	03117600	1S2473D
	or 46086000	1S1588
vD3	03117600	1S2473D
	or 46086000	1S1588
vD4	03117600	1S2473D
	or 46086000	1S1588
vRL1	11504700	Relay
●Transistor		
wQ15	46359701	2SA952
wQ16	46359801	2SC2001
wQ17	46359801	2SC2001
wQ18	46359801	2SC2001
wQ20	46367001	2SA1115
	or 46392001	2SA1175
wQ21	46367001	2SA1115
	or 46392001	2SA1175
wQ22	46367101	2SC2603
	or 46391901	2SC2785
wQ23	46367101	2SC2603
	or 46391901	2SC2785

Parts No.	Stock No.	Description
wQ24	46367101	2SC2603
	or 46391901	2SC2785
●Diode		
wD26	03117600	1S2473D
	or 46086000	1S1588
wD35	03117600	1S2473D
	or 46086000	1S1588
wD36	03117600	1S2473D
	or 46086000	1S1588
wD37	03117600	1S2473D
	or 46087000	1S1588
wD38	03117600	1S2473D
	or 46086000	1S1588
wD39	03117600	1S2473D
	or 46087000	1S1588
wD40	03117600	1S2473D
	or 46086000	1S1588
wR41	46249200	82Ω 1/2W N.I.R.
wR42	46249200	82Ω 1/2W N.I.R.
wC14	07216600	4700pF 25V C.C.
wC22	07215800	10000pF 25V C.C.
wC25	08451000	10μF 16V E.B.

5-3. F-3816 Mic Amp. & Auto Level Control Circuit Board (Stock No. 00711101)

Component Side

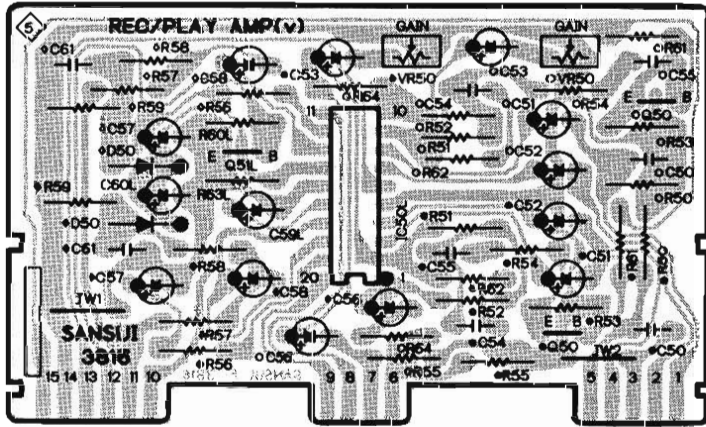

* Note: On this circuit board, the left channel is specified by "○" or "◇" mark on top of the parts No.

Parts List

Parts No.	Stock No.	Description
●Transistor		
vQ50	46367101	2SC2603
	or 46391901	2SC2785
vQ51	46367101	2SC2603
	or 46391901	2SC2785
●IC		
vIC50	46362100	M51161P
●Diode		
vD50	03117600	1S2473D
	or 46086000	1S1588
vC50	07215000	2200pF 25V C.C.
vC54	07216300	27000pF 25V C.C.
vC55	07216200	22000pF 25V C.C.
vC61	07216300	27000pF 25V C.C.
vVR50	07261500	500Ω (B) S.V.R., P.B Level adj.

5-4. F-3817 Noise Reduction Circuit Board (Stock No. 00711201)

Component Side

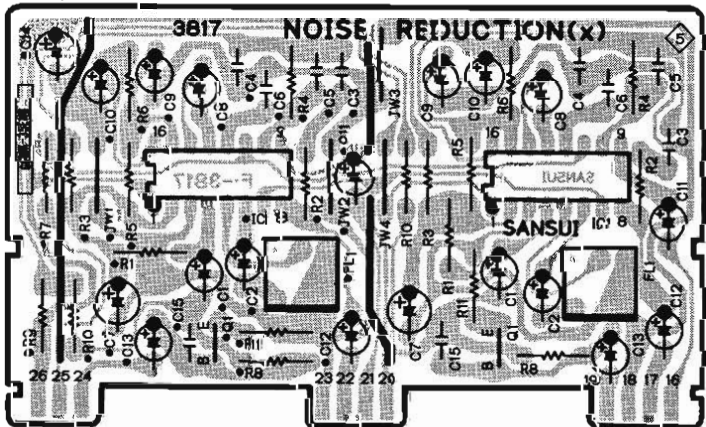

* Note: On this circuit board, the left channel is specified by "●" mark on top of the parts No.

Parts List

Parts No.	Stock No.	Description
●Transistor		
xQ1	46367101	2SC2603
	46391901	2SC2785
●IC		
xIC1	46128200	TA7629P
xC3	07215500	5600pF 25V C.C.
xC4	07216300	27000pF 25V C.C.
xC5	07215400	4700pF 25V C.C.
xC6	07216600	47000pF 25V C.C.
xFL1	46438200	Low Pass Filter

5-5. F-3818 REC Amp. Circuit Board (Stock No. 00711301)

Component Side

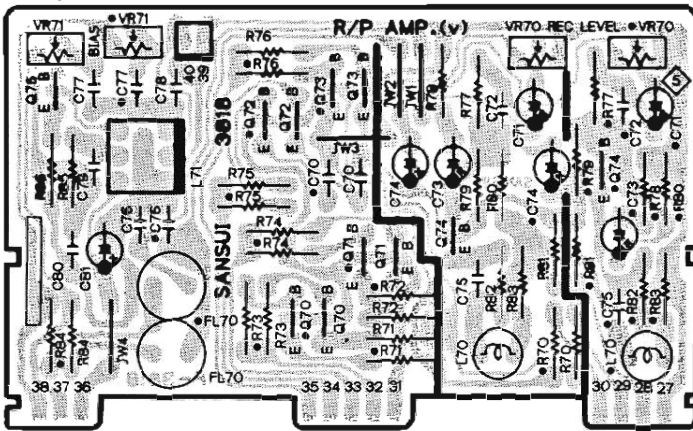

* Note: On this circuit board, the left channel is specified by "●" mark on top of the parts No.

Parts List

Parts No.	Stock No.	Description
● Transistor		
vQ70	46367101	2SC2603
	or 46391901	2SC2785
vQ71	46367101	2SC2603
	or 46391901	2SC2785
vQ73	46367101	2SC2603
	or 46391901	2SC2785
vQ74	46367101	2SC2603
	or 46391901	2SC2785
vQ75	46362301	2SC1627
vC75	07216300	27000pF 25V C.C.
vC78	00405200	3900pF 100V M.P.
vC79	07215400	4700pF 25V C.C.
vC80	07215400	4700pF 25V C.C.
vFL70	42904400	Bias Trap
vL70	46313900	Inductor 2.7mH
vL71	46362200	Bias OSC Coil
vVR70	07262100	50kΩ (B) S.V.R., Rec Level adj.
vVR71	07262100	50kΩ (B) S.V.R., Bias adj.

● Note: The circuit boards, F-3824, F-3880, F-3881, F-3882 & F-3883 are not supplied as the assembled. However, the individual parts on the circuit boards are provided by orders.

5-6. F-3824 Power Switch Circuit Board

Component Side

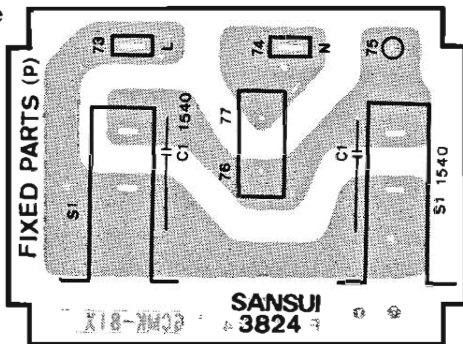

Parts List

Parts No.	Stock No.	Description
pC1	46425800	10000pF 400V C.C.
pZ20	46360300	Push SW., Power

5-7. F-3880 Control Switch Circuit Board

Component Side

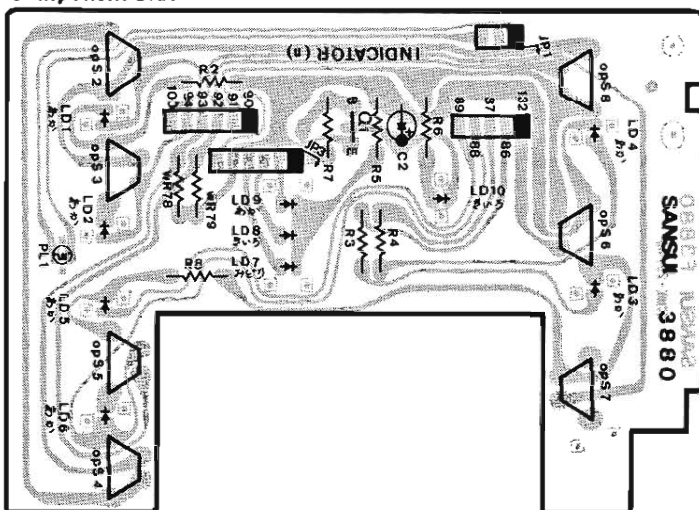

Parts List

Parts No.	Stock No.	Description
● Transistor		
nQ1	46367101	2SC2603
	or 46391901	2SC2785
● Light Emitting Diode		
nLD1	46176900	TLS-123 (Red)
nLD2	46176900	TLS-123 (Red)
nLD3	46176900	TLS-123 (Red)
nLD4	46176900	TLS-123 (Red)
nLD5	46176900	TLS-123 (Red)
nLD6	46176900	TLS-123 (Red)
nLD7	07250900	TLG-123 (Green)
nLD8	07251000	TLY-123 (Yellow)
nLD9	46176900	TLS-123 (Red)
nLD10	07251000	TLY-123 (Yellow)
nPL1	46315900	Pilot Lamp 12V 150mA
oPS2	46395900	Push SW. (REW)
oPS3	46395900	Push SW. (FF)
oPS4	46395900	Push SW. (FWD PLAY)
oPS5	46395900	Push SW. (REV PLAY)
oPS6	46395900	Push SW. (REC)
oPS7	46395900	Push SW. (STOP)
oPS8	46395900	Push SW. (PAUSE)

5-8. F-3881 Compu Edit. & TIMER Switch Circuit Board

Component Side

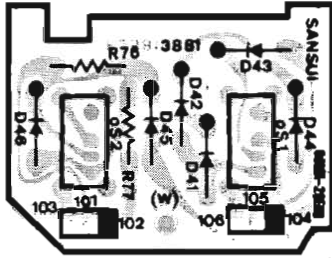

Circuit Board

Parts List

Parts No.	Stock No.	Description
oS1	46408600	Slide SW., Compu Edit. TIMER
oS2	46408600	Slide SW., REVERSE MODE
●Diode		
wD41	03117600	1S2473D
	or 46086000	1S1588
wD42	03117600	1S2473D
	or 46086000	1S1588
wD43	03117600	1S2473D
	or 46086000	1S1588
wD44	03117600	1S2473D
	or 46086000	1S1588
wD45	03117600	1S2473D
	or 46086000	1S1588
wD46	03117600	1S2473D
	or 46086000	1S1588
wD48	03117600	1S2473D
	or 46086000	1S1588

● Abbreviations

C.R. : Carbon Resistor	E.B. : Bi-Polar Electrolytic Capacitor
S.R. : Solid Resistor	E.B.L. : Low Leak Bi-Polar Electrolytic Capacitor
Ce.R. : Cement Resistor	
M.R. : Metal Film Resistor	Ta.C. : Tantalum Capacitor
F.R. : Fusing Resistor	F.C. : Film Capacitor
N.I.R. : Non-Inflammable Resistor	M.P. : Metallized Paper Capacitor
C.C. : Ceramic Capacitor	P.C. : Polystyrene Capacitor
C.T. : Ceramic Capacitor, Temperature Compensation	G.C. : Gimmic Capacitor
E.C. : Electrolytic Capacitor	V.R. : Variable Resistor
E.L. : Low Leak Electrolytic Capacitor	S.V.R. : Semi Variable Resistor
	SW. : Switch

5-9. F-3882 Headphone Jack Circuit Board

Component Side

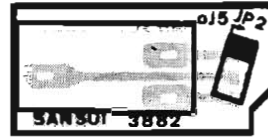

Parts List

Parts No.	Stock No.	Description
oJ5	46265700	Jack, Head Phone

5-10. F-3883 AMPS & DOLBY NR Switch Circuit Board

Component Side

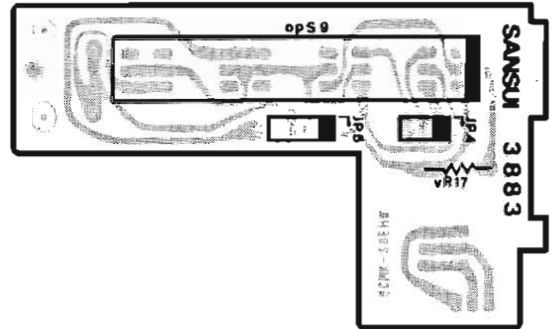

Parts List

Parts No.	Stock No.	Description
oPS9	46408900	Push SW., Tape Selector-DOLBY NR-REC MUTE

6. OTHER PARTS

6-1. Display Stage

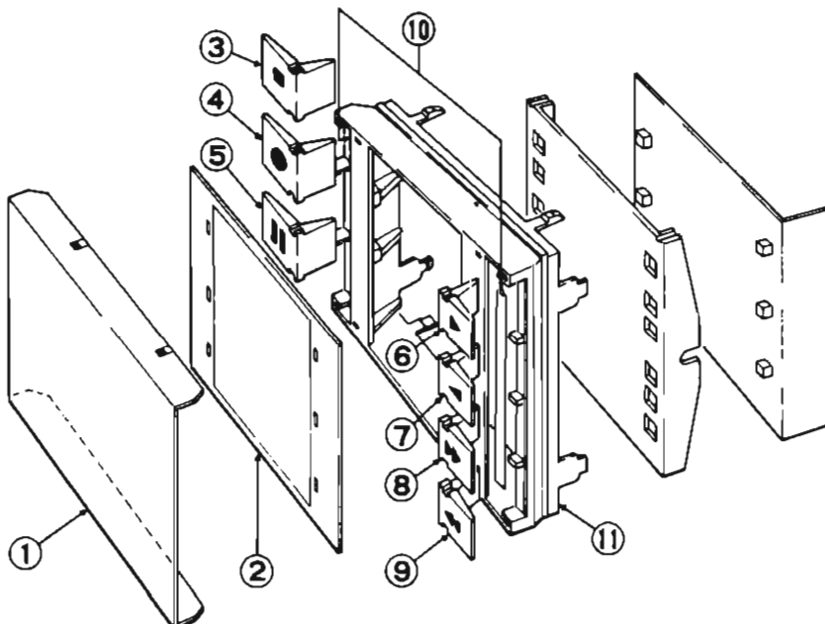

Parts List <Display Stage>

Parts No.	Stock No.	Description
1	47020500	Display Cover
2	47020200	Display Panel (Silver Model)
	07967300	Display Panel (Black Model)
3	07925900	Push Knob, STOP
4	07926200	Push Knob, REC
5	07926000	Push Knob, PAUSE
6	07924700	Push Knob, FWD PLAY
7	07924600	Push Knob, REV PLAY
8	07924800	Push Knob, FF
9	07924900	Push Knob, REW
10	47071400	Cushion Rubber
11	47020400	Display Holder (Silver Model)
	07921900	Display Holder (Black Model)

6-2. Front View

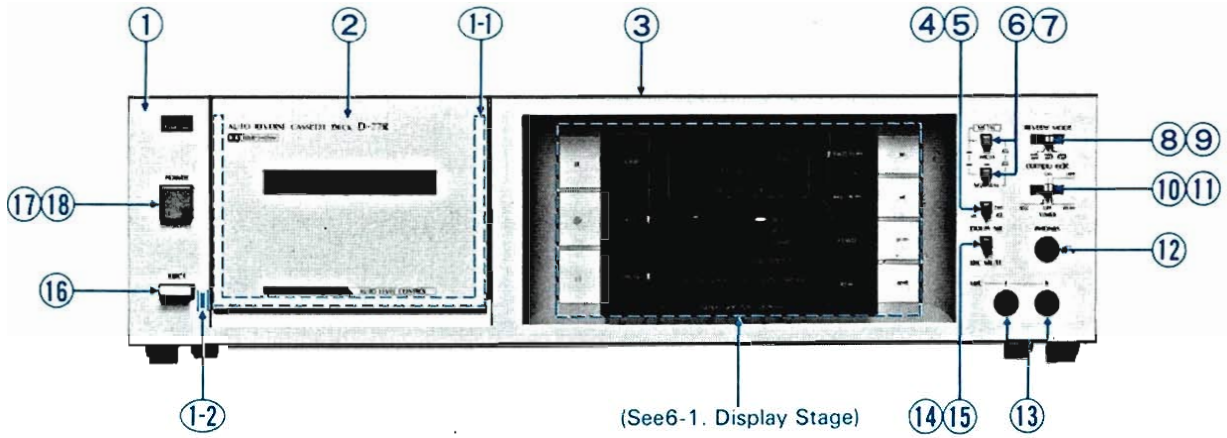

6-3. Top View

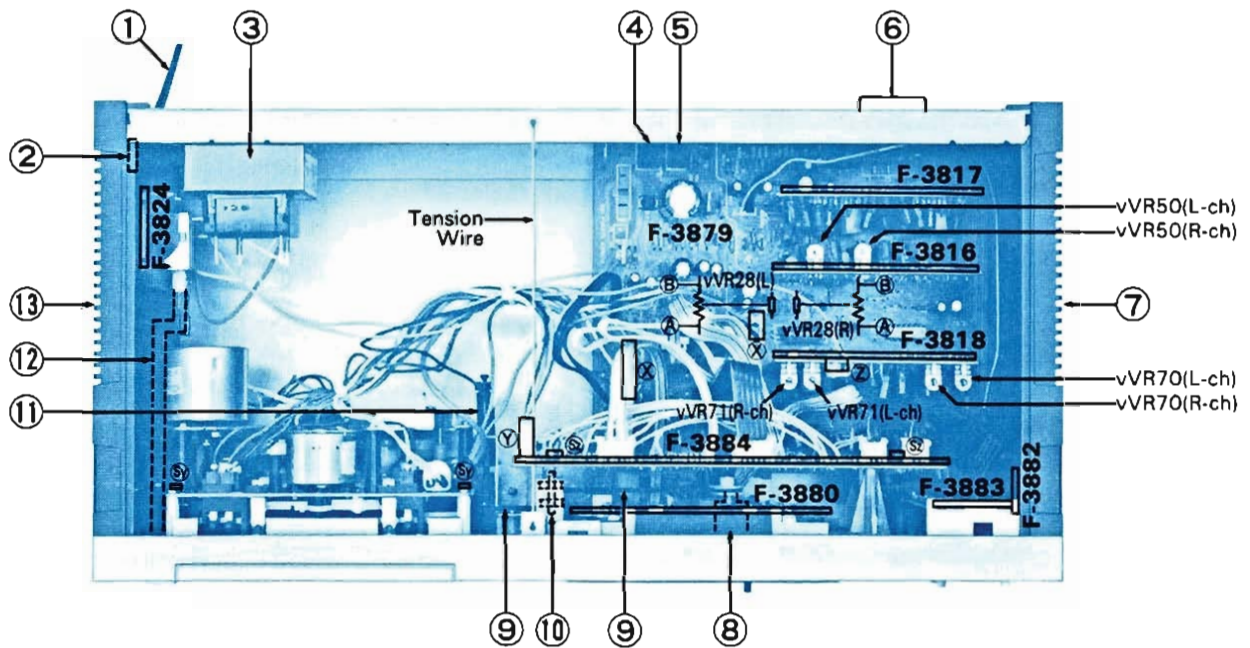

Parts List <Front View>

Parts No.	Stock No.	Description
1	47009200	Front Panel Ass'y (Silver Model)
	47009300	Front Panel Ass'y (Black Model)
1-1	07992300	Cassette Well Ass'y
1-2	47079700	Cassette Well Spring
2	07966700	Cassette Lid Ass'y (Silver Model)
	07966800	Cassette Lid Ass'y (Black Model)
3	07966900	Bonnet
4	47005600	Push Knob, DOLBY NR (Silver Model)
	07917300	Push Knob, DOLBY NR (Black Model)
5	46408900	Push SW., DOLBY NR
6	47005600	Push Knob, tape selector (Silver Model)
	07917300	Push Knob, tape selector (Black Model)
7	46408900	Push SW., tape selector
8	07945600	Slide Knob, REVERSE MODE (Silver Model)
	07945700	Slide Knob, REVERSE MODE (Black Model)
9	46408600	Slide SW., REVERSE MODE
10	07945600	Slide Knob, Compu Edit·TIMER (Silver Model)
	07945700	Slide Knob, Compu Edit·TIMER (Black Model)
11	46408600	Slide SW., Compu Edit·TIMER
12	46265700	Head Phone Jack
13	46212000	Mic Jack
14	47005600	Push Knob, REC MUTE (Silver Model)
	07917300	Push Knob, REC MUTE (Black Model)
15	46408900	Push SW., REC MUTE

Parts No.	Stock No.	Description
16	07945400	Push Knob, EJECT <Silver Model>
	07945500	Push Knob, EJECT <Black Model>
17	07971210	Push Knob, Power <Silver Model>
	07911210	Push Knob, Power <Black Model>
18	46360300	Push SW., Power

Parts List <Top View>

Parts No.	Stock No.	Description
1	38005400	Power Supply Cord
2	07917700	Power Supply Cord Cover
3	15009001	Power Transformer
4	46148200	Mini Jack, Compu Edit.
5	46148200	Mini Jack, Compu Selector
6	46371500	4P Input-Output Terminal, REC/PLAY
7	07952700	Side Panel Ass'y (Right)
8	46370400	Tape Counter
9	07976700	Belt, Counter
10	07920600	Pulley
11	46370300	Eject Dumper
12	07920700	Joint Shaft, Power Switch
13	07952600	Side Panel Ass'y (Left)

7. EXPLODED VIEW & PARTS LIST

• Though every part included in mechanism ass'y is numbered in exploded view, part unlisted in the parts list are not supplied.

7-1. Front View of Mechanism Chassis

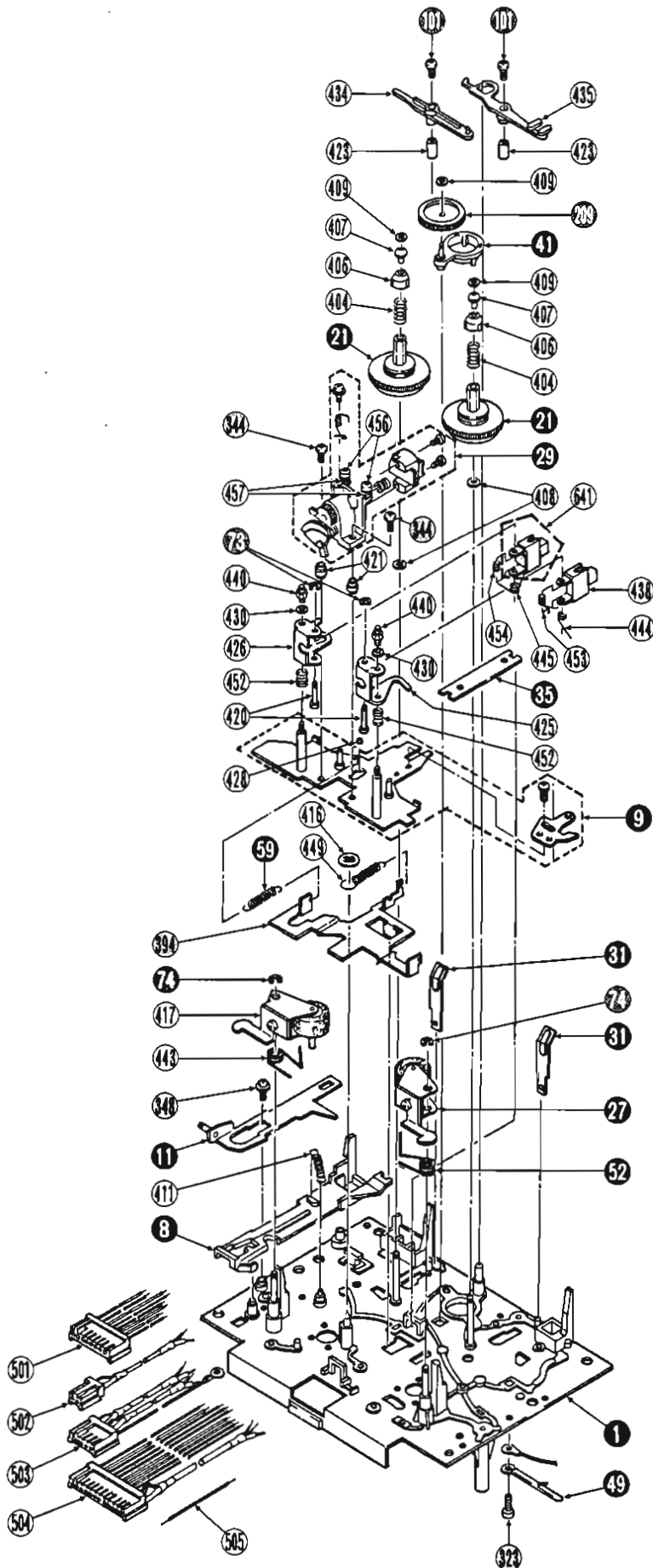

Parts List <Front View of Mechanism Chassis>

Parts No.	Stock No.	Description
8	47014400	Slider Lock Plate
21	47014600	Reel Hub
27	47059500	Pinch Roller Ass'y (FWD)
29	47063000	REC/PB Head Ass'y (with Erase Head)
31	47059700	Cassette Hold Spring
35	47015200	Slider Hold Plate Spring
41	47015300	Idler Gear Arm
52	47059800	Pinch Roller Spring (FWD)
59	47060000	Play Slider Plate Spring
73	00488900	E ring d = 1.5
74	00489000	E ring d = 2.0
101	00421500	Binding Head Screw M2.6 x 10
209	47016500	Idler Gear
323	47017200	Binding Head Deltite M2.6 x 6
344	47060200	Binding Head Deltite M2.0 x 8
348	47004600	Washer Head Tapping Screw M2.6 x 8
404	47018800	Reel Spring
406	47019000	Reel Collar
407	47019100	Reel Cap
408	07513000	Thrust Washer d = 2.0
409	47019200	Thrust Washer d = 1.6
411	47019400	Lock Slider Spring
416	51832300	CS Type Ring d = 5.0
417	47059600	Pinch Roller (REV)
420	47060600	Pin, Tape Guide
421	47060700	Spacer, Head Ass'y
423	47060900	Spacer, Release Lever
428	63220100	Steel Ball
430	51829900	Thrust Washer
434	47061200	Transfer Lever
435	47061300	Release Lever
438	47061400	Tape Guide
440	47061600	Nut, Tape Guide Adjusting
443	47059900	Pinch Roller Spring (REV)
444	47061900	Tape Guide Spring (1)
445	47062000	Photo Sensor Spring (1)
449	47062300	Play Slider Spring
452	47062600	Tape Guide Lever Spring
453	47062700	Tape Guide Spring (2)
454	47062800	Photo Coupler Spring (2)
456	47077600	Binding Head Screw M2.0 x 6
457	47077700	Head Adjust Spring
641	47062900	Photo Coupler Ass'y

• Abbreviations

1. Pan Head Tapping Screw FT Type	6. Binding Head SEMS F Screw BSF Type	11. Hex. Socket Setscrew SC Type	16. Retaining Ring (E Washers) E Type
2. Washer Head Tapping Screw WT Type	7. Binding Head Screw B Type	12. Slot Type Setscrew SS Type	17. Toothed Lock Washer (External) TLE Washer
3. Pan Head Screw P Type	8. Flat Counter Sunk Head Screw F Type	13. Binding Head SEMS B Screw BSB Type	18. Wave Washer
4. Pan Head SEMS A Screw PSA Type	9. Flat Counter Sunk Wood Screw FC Type	14. Spring Washer S Type	19. Hexagon Nut H Type Nut
5. Pan Head SEMS B Screw PSB Type	10. Round Head Wood Screw RM Type	15. Plain Washer P Type	

7-2. Rear View of Mechanism Chassis

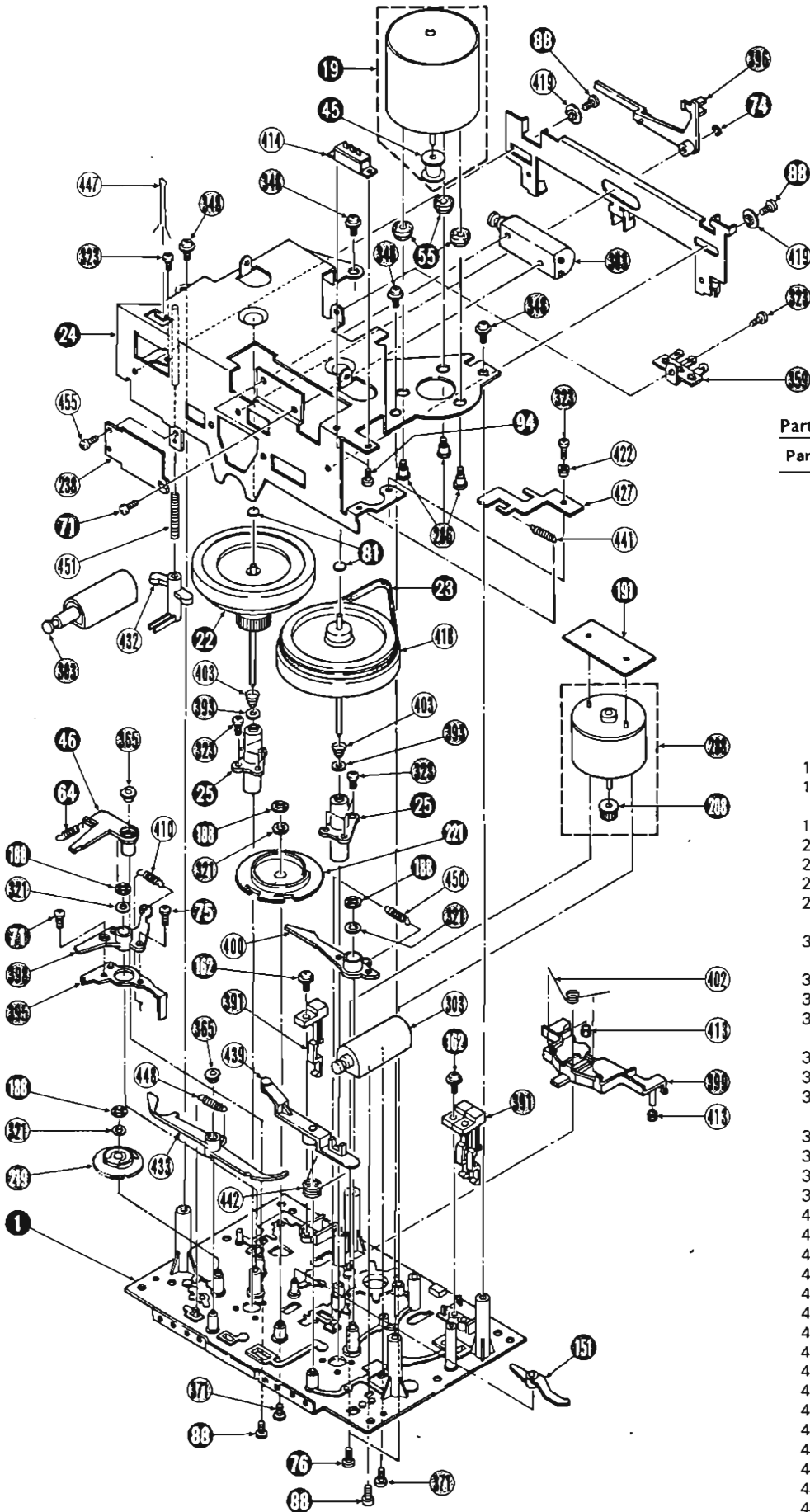

- 1 ~ 59
- 60 ~ 229
- 230 ~ 399
- 400 ~ 641

Parts List <Rear View of Mechanism Chassis>

Parts No.	Stock No.	Description
19	47059100	Capstan Motor Ass'y (with Pulley ⑤)
22	47059200	Flywheel Ass'y (FWD Capstan)
23	47059400	Capstan Belt
46	47015500	AMPS Lock Lever
55	47015700	Cushion, Motor
64	47016000	AMPS Lock Lever Spring
71	07736400	Binding Head Screw M2.6 x 3
74	00489000	E ring d = 2.0
75	47016200	Binding Head Screw M2.6 x 5
76	00421400	Binding Head Screw M2.6 x 8
88	00421200	Binding Head Screw M2.6 x 4
94	00420600	Binding Head Screw M2.0 x 5
151	47016300	Brake Lever
162	00440500	Pan Head Tapping Screw M2.6 x 8
188	51822900	CS Type Ring d = 3.0
219	47016600	Cam Gear, AMPS
221	47060100	Cam Gear, Play
286	47016800	Special Screw M2.6 x 1.8
288	47016900	Reel Motor Ass'y (with Gear ②)
303	47017100	Plunger Solenoid, (play - pause - change)
321	00466400	Plain Washer d = 3.0
323	47017200	Binding Head Deltite M2.6 x 6
348	47004600	Washer Head Tapping Screw M2.6 x 8
365	47017300	Bush
371	00424700	Binding Head Screw M2.6 x 3
391	47017700	Leaf Switch, rec prevention - cassette sensor
393	47017800	Washer d = 2.5
396	47060300	Direction Change Plunger Lever
398	47018200	AMPS Lever
399	47018300	Brake Slider
400	47018400	Play Lever
402	47018600	Brake Spring
403	47018700	Flywheel Spring
410	47019300	Play Lever Spring
413	47019600	Cushion, Brake
414	47060400	Slide SW.
418	47059300	Flywheel Ass'y (REV Capstan)
419	47060500	Collar, direction change plate
422	47060800	Spacer Assist Lever
432	47061000	Shift Lever
433	47061100	Direction Change Lever
439	47061500	Play Plunger Lever
441	47061700	Assist Lever Spring
442	47061800	Play Plunger Lever Spring
447	47062100	Shift Lever Spring
448	47062200	Direction Change Lever Spring
450	47062400	Play Lever Spring
451	47062500	Shift Lever Spring
455	00421400	Binding Head Deltite M2.6 x 8

8. MAIN PARTS REPLACEMENT

A. Mechanism assembly

(See EXPLODED VIEW and Top View on Page 10)

- 1) Remove the bonnet and the bottom plate.
- 2) Cut off two vinyl bands for bundling wires.
- 3) Extract two connectors (X) on the main circuit board F-3879.
- 4) Extract a connector (Y) on the mechanism control circuit board F-3884.
- 5) Extract a connector (Z) on the mechanism control circuit board F-3818.
- 6) Remove four screws (Sv) fixing mechanism assembly.
- 7) Take off the counter belt from the reel hub.
- 8) Pull out the mechanism assembly from the rear panel side.

B. Reel motor assembly (208)

- 1) Pull out the mechanism assembly from the rear panel side.
- 2) Remove two screws (76) fastening reel motor and idler gear arm (41).
- 3) Pull out reel motor assembly from the back side.

C. Idler gear (209)

- 1) Pull out the mechanism assembly from the rear panel side.
- 2) Remove the washer (409) retaining the idler gear.
- 3) Remove the idler gear from idler gear arm.

D. Reel hub (21) · Cushion (brake) (413)

- 1) Pull out the mechanism assembly from the rear panel side.
- 2) Remove the thrust washer (409), reel cap (407), reel collar (400) and reel spring (404) and extract the reel hub.
- 3) Extract the cushion (brake) from the brake slider (399).

E. Capstan motor (19), flywheel (22) · (418)

- 1) Pull out the mechanism assembly from the rear panel side.
- 2) Remove four screws (348) and two screws (324) fixing the capstan motor mounting plate.
- 3) Remove one screw (435) fixing connection terminal circuit board (28).
- 4) Remove three screws (286) fixing the capstan motor.
- 5) Take out the flywheel from mechanism assembly.

F. Play cam gear (271)

- 1) Perform the same manner as for the flywheel.
- 2) Remove two screws (88), (371) fixing play plunger solenoid (303).
- 3) Remove the play plunger lever (430).
- 4) Remove the CS type ring (188) retaining the play cam gear.
- 5) Take out the plain washer (321) and extract the play cam gear.

G. AMPS cam gear (219)

- 1) Perform the same manner as for the flywheel.
- 2) Remove the AMPS lock lever spring (64) from the AMPS lock lever (46).
- 3) Remove the bush (365) fastening AMPS lock lever and take out the AMPS lock lever.
- 4) Remove the CS type ring (188) fastening AMPS cam gear.
- 5) Remove the plain washer (321) and extract the AMPS cam gear.

H. Side panel L (R)

- 1) Remove four screws (Sx) fixing side panel L (R) from rear panel side.
- 2) Remove bonnet and bottom plate.
- 3) Shift the position of the side panel L (R) 2 cm in the arrow direction (1) and then pull it the arrow direction (2) to remove the side panel L (R). (See Fig. 8-1)

Fig. 8-1

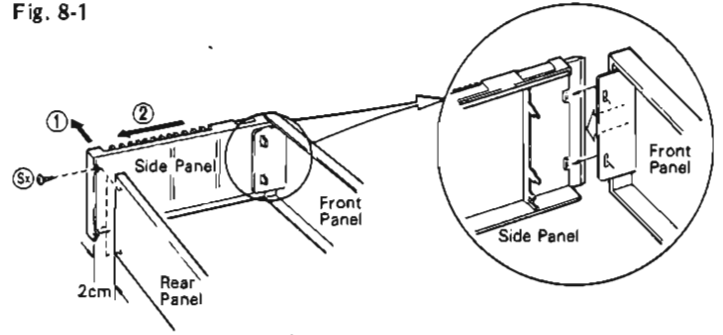

I. Display stage

- 1) Remove the side panel L and R. (See Replacement H)
- 2) Remove tension wire (See top view on page 10)
- 3) Remove the front panel assembly with mechanism assembly and mechanism control circuit board F-3884.
- 4) Remove two screws (S2) fixing mechanism control circuit board F-3884. (See top view on page 10)
- 5) Remove the mechanism control circuit board F-3884 from front panel assembly.
- 6) Take off the tape counter belt from counter pulley. (See top view on page 10)
- 7) Remove the tape counter holder from front panel (See Fig. 8-2)
- 8) Remove the control switch circuit board F-3880 from display stage. (See Fig. 8-2)
- 9) Remove display stage from front panel assembly.

Fig. 8-2

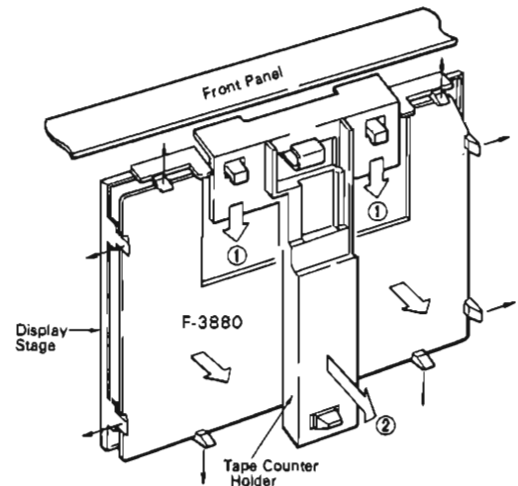

J. Front panel assembly

- 1) Perform the same manner as for the display stage.
- 2) Remove the mechanism assembly.
- 3) Remove the circuit board F-3882, F-3883 from front panel assembly (See top view on page 10)

9. WIRING OF MECHANISM Ass'y

9-1. Motors & Plungers

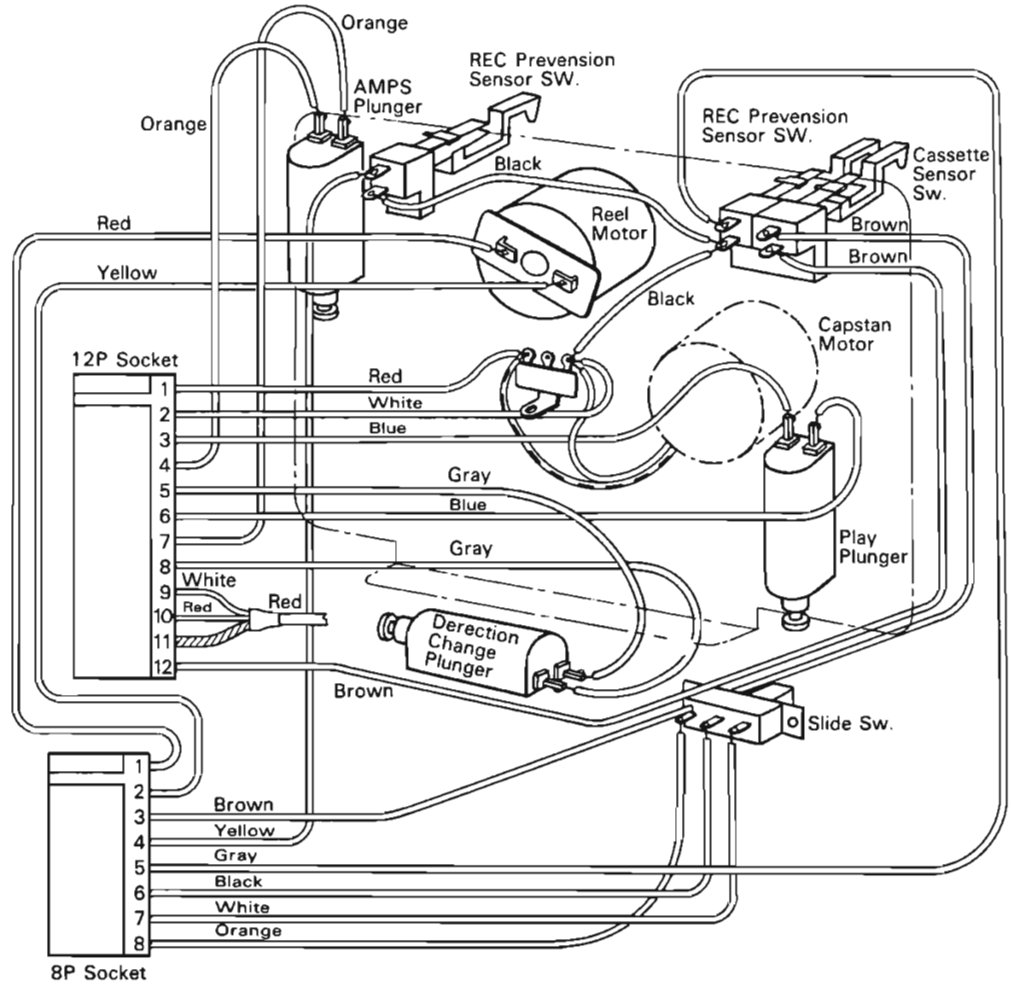

9-2. Head Ass'y & Photo Coupler

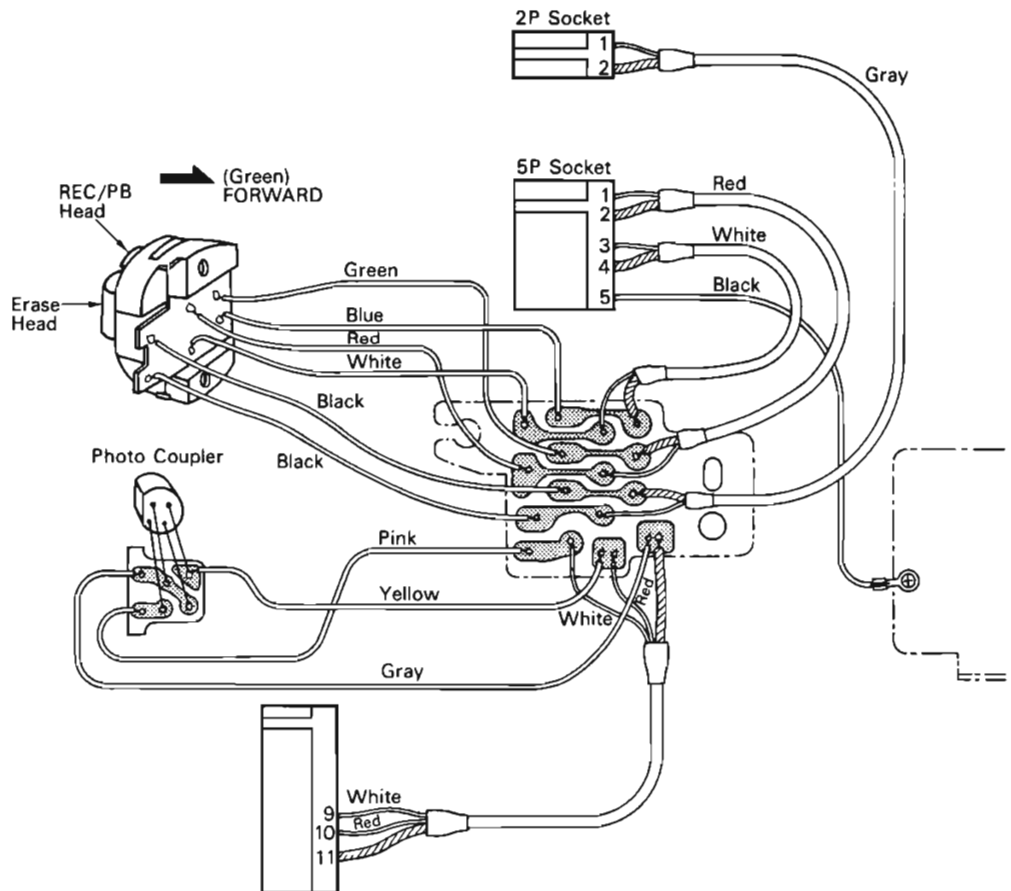

10. SCHEMATIC DIAGRAM 10-1. Amp. Section

*On the F-3816 circuit board, L-ch is specified by "○" or "○" mark on top of the parts No.
 *On the F-3817, F-3818 circuit board, L-ch is specified by "●" mark on top of the parts No.

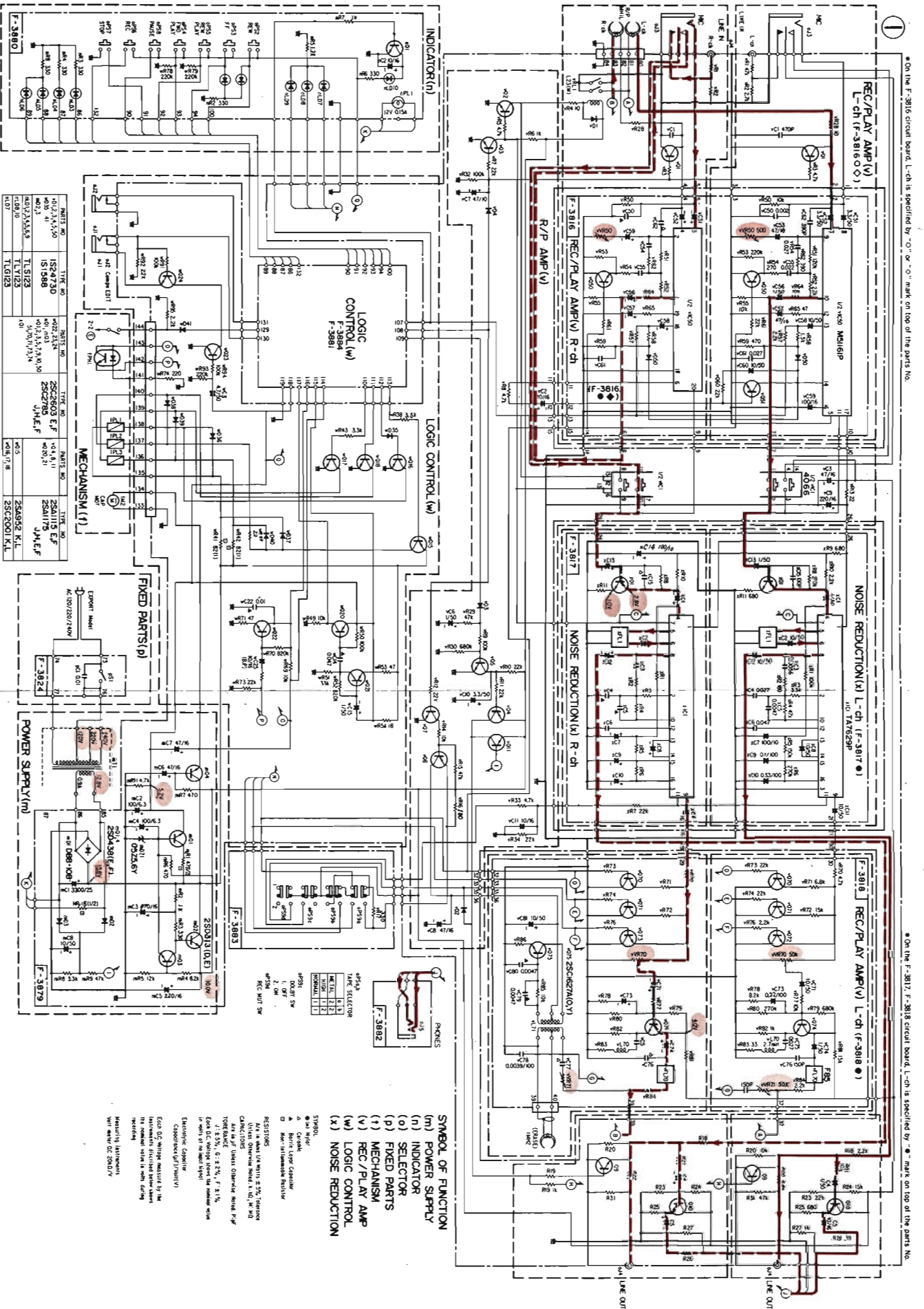

A

B

C

D

10-2. Mechanism Control Section

*Design and specifications subject to change without notice for improvement.
 *La présentation et les spécifications sont susceptibles d'être modifiées sans préavis par suites d'améliorations éventuelles.
 *Änderungen, die dem technischen Fortschritt dienen, bleiben vorbehalten.

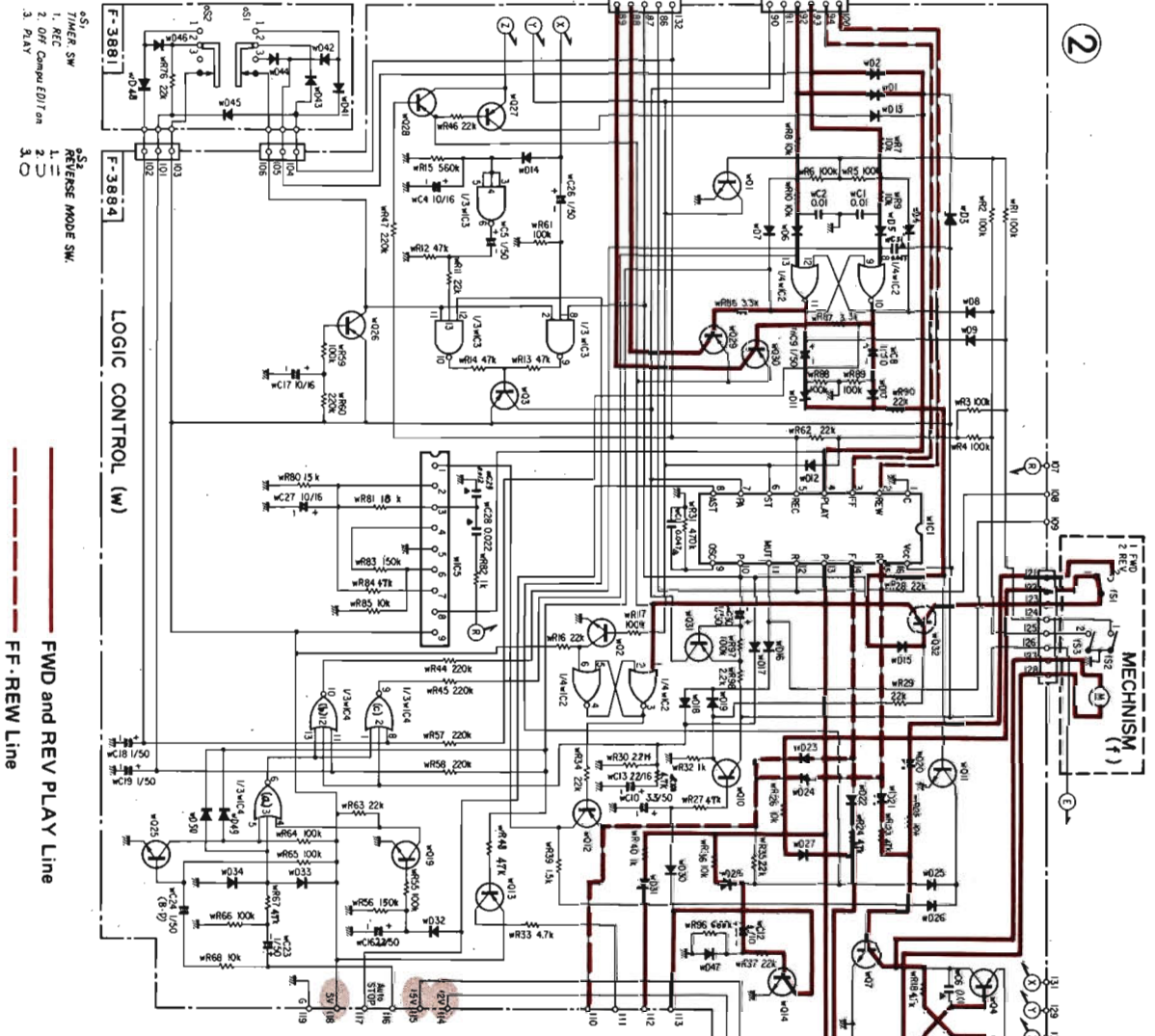

0.5
 1
 2
 3
 4
 5
 6
 7
 8
 9
 10
 11
 12
 13
 14
 15
 16
 17
 18
 19
 20
 21
 22
 23
 24
 25
 26
 27
 28
 29
 30
 31
 32
 33
 34
 35
 36
 37
 38
 39
 40
 41
 42
 43
 44
 45
 46
 47
 48
 49
 50
 51
 52
 53
 54
 55
 56
 57
 58
 59
 60
 61
 62
 63
 64
 65
 66
 67
 68
 69
 70
 71
 72
 73
 74
 75
 76
 77
 78
 79
 80
 81
 82
 83
 84
 85
 86
 87
 88
 89
 90
 91
 92
 93
 94
 95
 96
 97
 98
 99
 100

— FWD and REV PLAY Line
 - - - FF-REW Line

OPTIONAL USE OF SEMICONDUCTOR	
PARTS NO.	TYPE NO.
D1~90	IS2473D
0,2,7,8,9,11,19,25	IS1588
0,3,4,5,10,12,13,28	2SC2803 E,F
27,28,29,30,31,32	2SC2785 J,H,F,E
	2SA1115 E,F
	2SA1175 J,H,F,E
IC 1	TC9143P
IC 2	JPD4001
IC 3	JPD4023
IC 4	JPD4025
IC 5	TA7341P

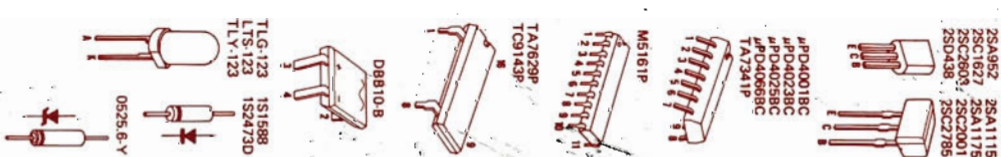
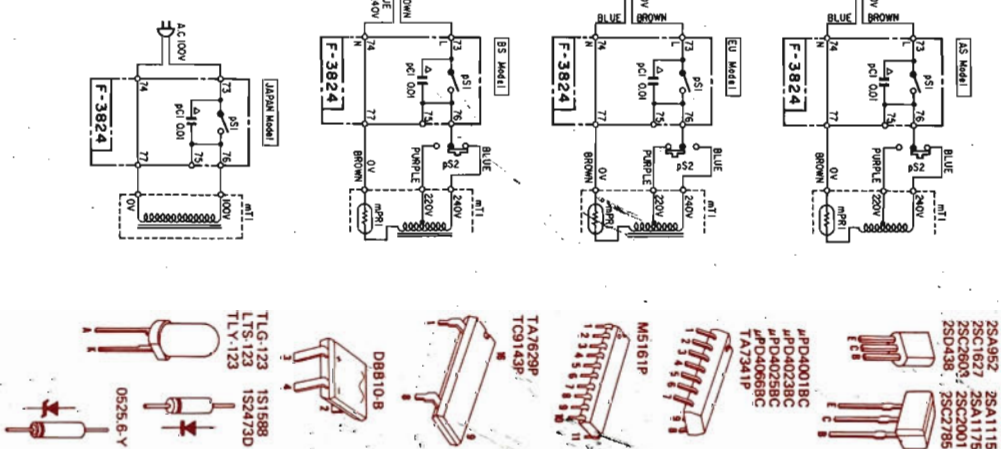

1
 2
 3
 4
 5
 14

11. PACKING LIST

Parts No.	Stock No.	Description
1	91263810	Vinyl Cover
2	07949000	Styrofoam Packing
3	07960000	Carton Case (Silver Model)
	07960800	Carton Case (Black Model)

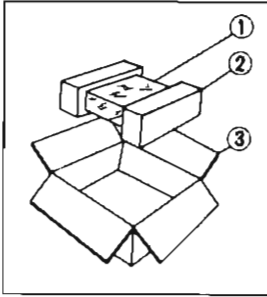

12. ACCESSORY LIST

Stock No.	Description
46357200	Operating Instruction
38103300	PJP Cord
46267300	Mini Plug Cord
94300500	Head Cleaner (Cotton Buds)



SANSUI ELECTRIC CO., LTD.:

SANSUI ELECTRONICS CORPORATION:

SANSUI ELECTRONICS (U.K.) LTD.:
SANSUI ELECTRONICS G.M.B.H.:

14-1, Izumi 2-chome, Suginami-ku, Tokyo 168 Japan

PHONE: (03) 324-8891/TELEX: 232-2076 (International Division)

1250 Valley Brook Ave. Lyndhurst, N.J. 07071 U.S.A.

333 West Alondra Blvd. Gardena, California 90247 U.S.A.

3036 Koapaka St. Honolulu, Hawaii 96819 U.S.A.

Unit 10A, Lyon Industrial Estate, Rockware Avenue, Greenford, Middx UB6, OAA, England

Paul Ehrlich Strasse 8, 6074 Rödermark 2, West Germany