

SERVICE MANUAL

AUTO REVERSE CASSETTE DECK

SANSUI D-79R

(Silver & Black Model)

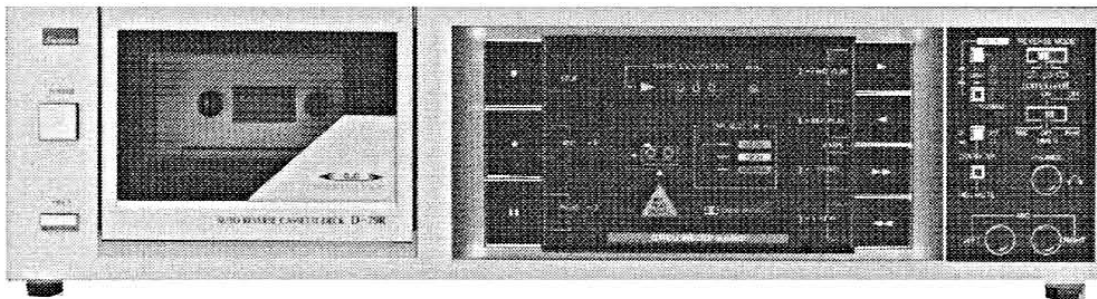

Note

D-79R is additional model which external appearances are different from those of D-77R.

This manual contains OTHER PARTS LIST, PACKING LIST and ACCESSORY LIST in which changed parts are printed with bold-face.

For other parts list, refer to D-77R service manual previously issued.

•SPECIFICATIONS

Track	4-Track (2-Channel Stereo)
Tape Speed	4.8 cm/sec. (1-7/8 ips)
Heads (2-head configuration)	
Rec/pb head.....	HIGH-Bs hard permalloy
Erase head.....	Double-gap HIGH-Bs ferrite
Motor	Capstan: Electronically Controlled DC Motor Reels: DC Motor
Wow and flutter	within 0.05% WRMS
Fast wind time	approximately 80 seconds (C-60)
Frequency response (-20 VU recording/playback)	
Normal Tape (LH).....	20 to 15,000 Hz (30 to 14,000 Hz ± 3 dB)
Chrome tape	20 to 17,000 Hz (30 to 16,000 Hz ± 3 dB)
Metal Tape	20 to 18,000 Hz (30 to 17,000 Hz ± 3 dB)
Signal to noise ratio (Record/Playback)	
Metal Tape (without Dolby Noise Reduction Effect) better than 58 dB (weighted)
(With Dolby Noise Reducton) better than 68 dB (above 5 kHz)
Erasure factor (Metal Tape) more than 70 dB at 1 kHz
Input sensitivity and impedance (0 VU, 1 kHz)	
MIC	0.4 mV/200 Ω ~ 5 k Ω
LINE IN (REC).....	150 mV/100 k Ω
Output level (0 VU, 1 kHz)	
LINE OUT (PLAY)	240 mV
Power requirements	
Power voltage.....	120/220/240 V (50/60 Hz) For U.S.A. and Canada 120 V (60 Hz)
Power consumption....	15 W
Dimensions	430 mm (16-15/16") W 118 mm (4-11/16") H 223 mm (8-13/16") D
Weight	4.0 kg (8.8 lbs.) net 4.8 kg (10.6 lbs.) packed

- Design and specifications subject to changes without notice for improvements.
- Noise reduction system manufactured under license from Dolby Laboratories Licensing Corporation.
"Dolby" and the double D symbol are trade marks of Dolby Laboratories Licensing Corporation.

Sansui

SANSUI ELECTRIC CO., LTD.

1. OTHER PARTS

1-1. Front View

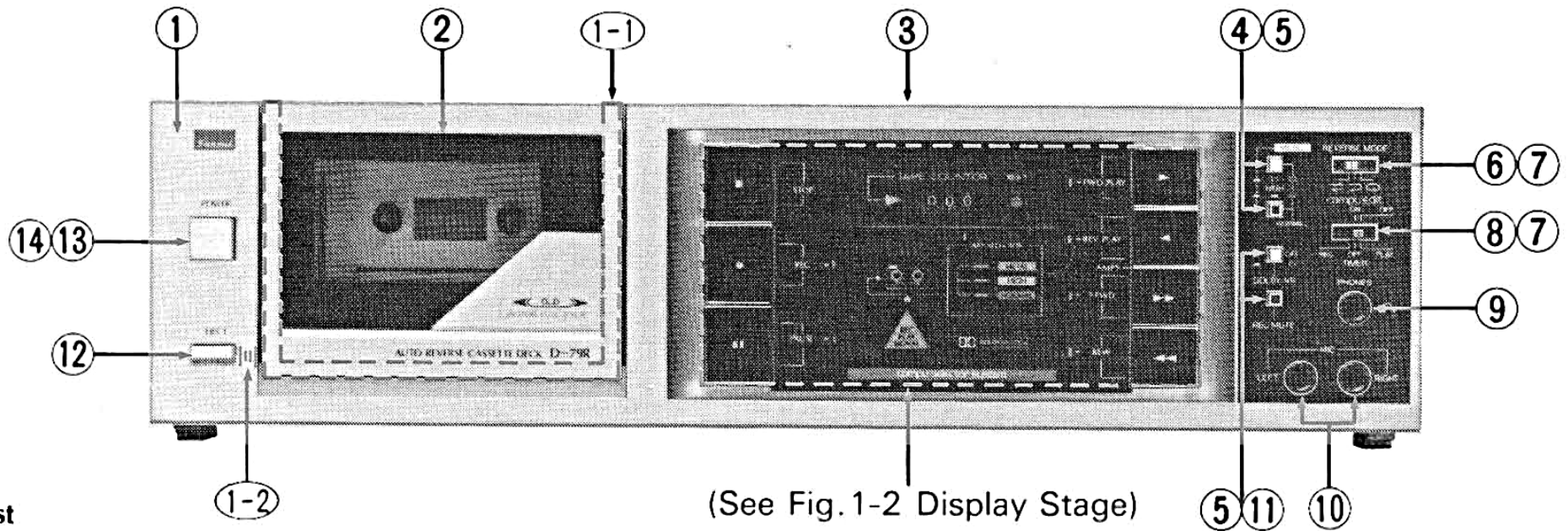

Parts List

Parts No.	Stock No.	Description
1	47527100	Front Panel Ass'y <Silver Model>
	47527200	Front Panel Ass'y <Black Model>
1-1	07992310	Cassette Well Ass'y
1-2	47079700	Cassette Well Spring
2	47413800	Cassette Lid Ass'y <Silver Model>
	47413900	Cassette Lid Ass'y <Black Model>
3	07966900	Bonnet
4	47234600	Push Knob, METAL/HIGH/NORMAL <Silver Model>
	07917300	Push Knob, METAL/HIGH/NORMAL <Black Model>
5	46408900	Push SW., METAL/HIGH/NORMAL•DOLBY NR•REC MUTE
6	47484100	Slide Knob, REVERSE MODE <Silver Model>
	07945710	Slide Knob, REVERSE MODE <Black Model>

Parts No.	Stock No.	Description
7	46408600	Slide SW., REVERSE MODE•COMPU EDIT/TIMER
8	07945710	Slide Knob, COMPU EDIT/TIMER
9	46265700	Jack, PHONES
10	46212000	Jack, MIC
11	47234600	Push Knob, DOLBY NR•REC MUTE <Silver Model>
	47419200	Push Knob, DOLBY NR•REC MUTE <Black Model>
12	07945400	Push Knob, EJECT <Silver Model>
	07945500	Push Knob, EJECT <Black Model>
13	07971210	Push Knob, POWER <Silver Model>
	07911210	Push Knob, POWER <Black Model>
14	46360300	Push SW., POWER

1-2. Display Stage

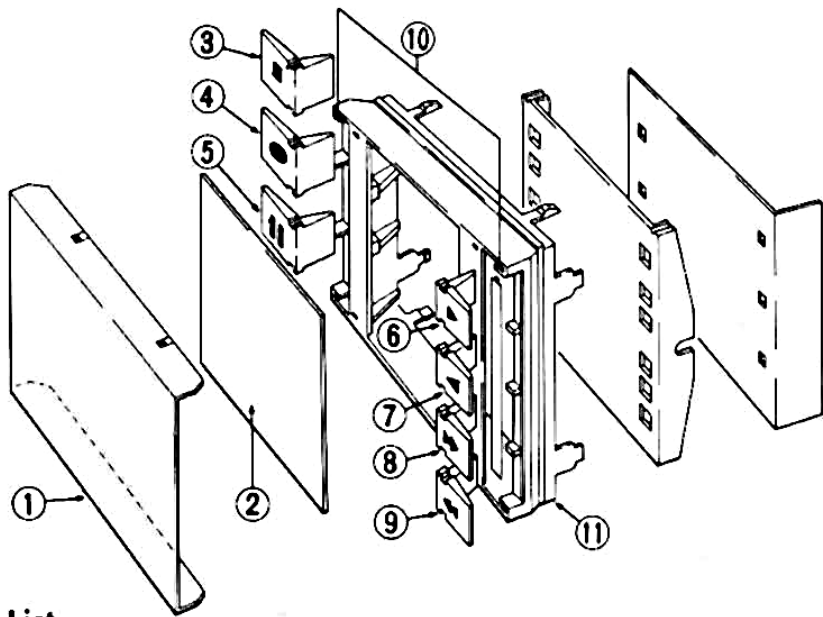

Parts List

Parts No.	Stock No.	Description
1	47415100	Display Cover
2	47414100	Display Panel
3	47434100	Push Knob, STOP
4	47434200	Push Knob, REC
5	47434300	Push Knob, PAUSE
6	47413100	Push Knob, FWD PLAY
7	47420000	Push Knob, REV PLAY
8	47420100	Push Knob, F. FWD
9	47420200	Push Knob, REW
10	47071400	Cushion Rubber
11	07921900	Display Holder

2. PACKING LIST

Parts No.	Stock No.	Description
1	91263810	Vinyl Cover
2	07949000	Styrofoam Packing
3	47412500	Carton Case <Silver Model>
	47412400	Carton Case <Black Model>

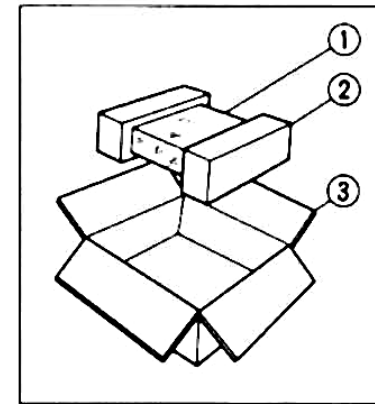

3. ACCESSORY LIST

Parts No.	Stock No.	Description
	46896600	Operating Instruction
	38103300	PJP Cord
	46267300	Mini Plug Cord
	94300500	Head Cleaner (cotton buds)



SANSUI ELECTRIC CO., LTD.:

SANSUI ELECTRONICS CORPORATION:

SANSUI ELECTRONICS (U.K.) LTD.:
SANSUI ELECTRONICS G.M.B.H.:

14-1, Izumi 2-chome, Suginami-ku, Tokyo 168 Japan
PHONE: (03) 324-8891/TELEX: 232-2076 (International Division)
1250 Valley Brook Ave. Lyndhurst, N.J. 07071 U.S.A.
17150 South Margay Ave. Carson, California 90746 U.S.A.
3036 Koapaka Street, Honolulu, Hawaii 96819 U.S.A.
Unit 10A, Lyon Industrial Estate, Rockware Avenue, Geenford, Middx UB6, OAA, England
Pau Ehrich Strasse 8, 6074 Rödermark 2, West Germany

(SM1-128)

Printed in Japan (140620M) <Stock No. 36488700>