

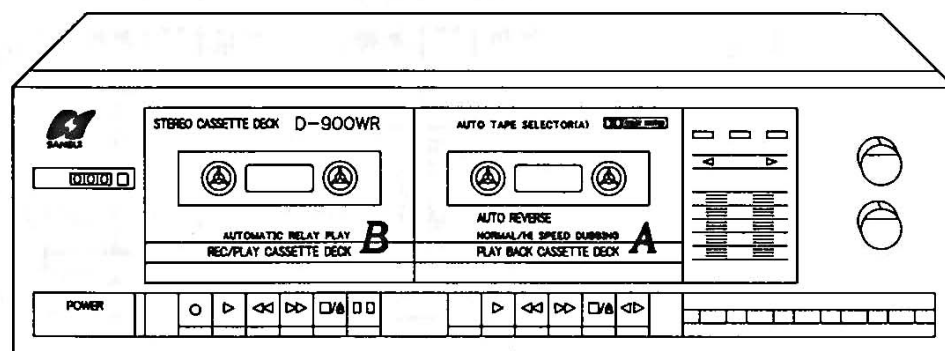

SERVICE MANUAL

D-900WR STEREO CASSETTE DECK



CAUTION

1. Parts identified by the Δ symbol on the schematic diagram and the parts list are critical for safety. Use only replacement parts that have critical characteristics recommended by the manufacturer.
2. Make leakage-current or resistance measurements to determine that exposed parts are acceptably insulated from the supply circuit before returning the appliance to the customer.

NOTICE

1. The symbols Type A and Type B on the block diagram, parts list and the schematic diagram mean followings respectively. Type A has the SYSTEM CONTROL jack on the rear panel. Type B does not have the SYSTEM CONTROL jack on the rear panel.
2. The symbols UL, CSA, EU, SEV, SS and XX <EXPORT> on the parts list and the schematic diagram mean followings respectively.
 - UL..... Manufactured for U.S.A. market.
(Underwriters Laboratories approved model.)
 - CSA..... Manufactured for Canadian market.
 - EU..... Manufactured for European market.
(Except Swiss market.)
 - SEV..... Manufactured for Swiss market.
 - SS..... Manufactured for Saudi Arabian market.
 - XX..... Standard Version.
 - <EXPORT>
 - NON MARK..... Common Parts.
3. Some printed circuit boards are not supplied assembled. To separate these in this service manual, the stock numbers are not indicated for these boards. However, stock numbers for individual parts are indicated.
4. Since some capacitors and resistors are omitted from parts lists in this service manual, refer to the Common Parts List for capacitors and resistors, which was issued on June 1987.
5. Abbreviations in this service manual are as follows.

Abbreviations List

F.R.	: Fusing Resistor	S.V.R.	: Semi Variable Resistor
C.C.	: Ceramic Capacitor	SW.	: Switch
P.C.	: Polystyrene Capacitor	Chip C.	: Chip Capacitor
V.R.	: Variable Resistor		

Specifications

Track format.....	4-track/2-channel system
Tape speed.....	4.75 cm/sec.
Wow/flutter.....	0.2% max (WRMS)
Fast forwarding (rewinding) time.....	Approx. 170 sec. (for C-60 tape)
Frequency response	
Normal tape (LH).....	70 to 13,000 Hz \pm 3 dB
Signal-to-noise ratio	
DOLBY NR ON.....	Better than 60 dB
Input sensitivity	
LINE IN (REC).....	100 mV
Power requirements	
	120/220~240 V 50/60 Hz
For U.S.A. and Canada	120 V (60 Hz)
European	220 V (50 Hz)

Power consumption.....	15 watts
Dimensions	430 mm (16-15/16")W 127 mm(5")H 232 mm (9-3/16")D
Weight	3.8 kg (8.4 lbs) net 4.7 kg (10.4 lbs) packed

- * Design and specifications subject to changes without notice for improvements.
- * Due to local laws and regulations, this unit sold in some areas are not equipped with variable voltage selectors.
- * Dolby noise reduction manufactured under license from Dolby Laboratories Licensing Corporation. "DOLBY", the double-D symbol (DD) are trade marks of Dolby Laboratories Licensing Corporation.

1. BLOCK DIAGRAM

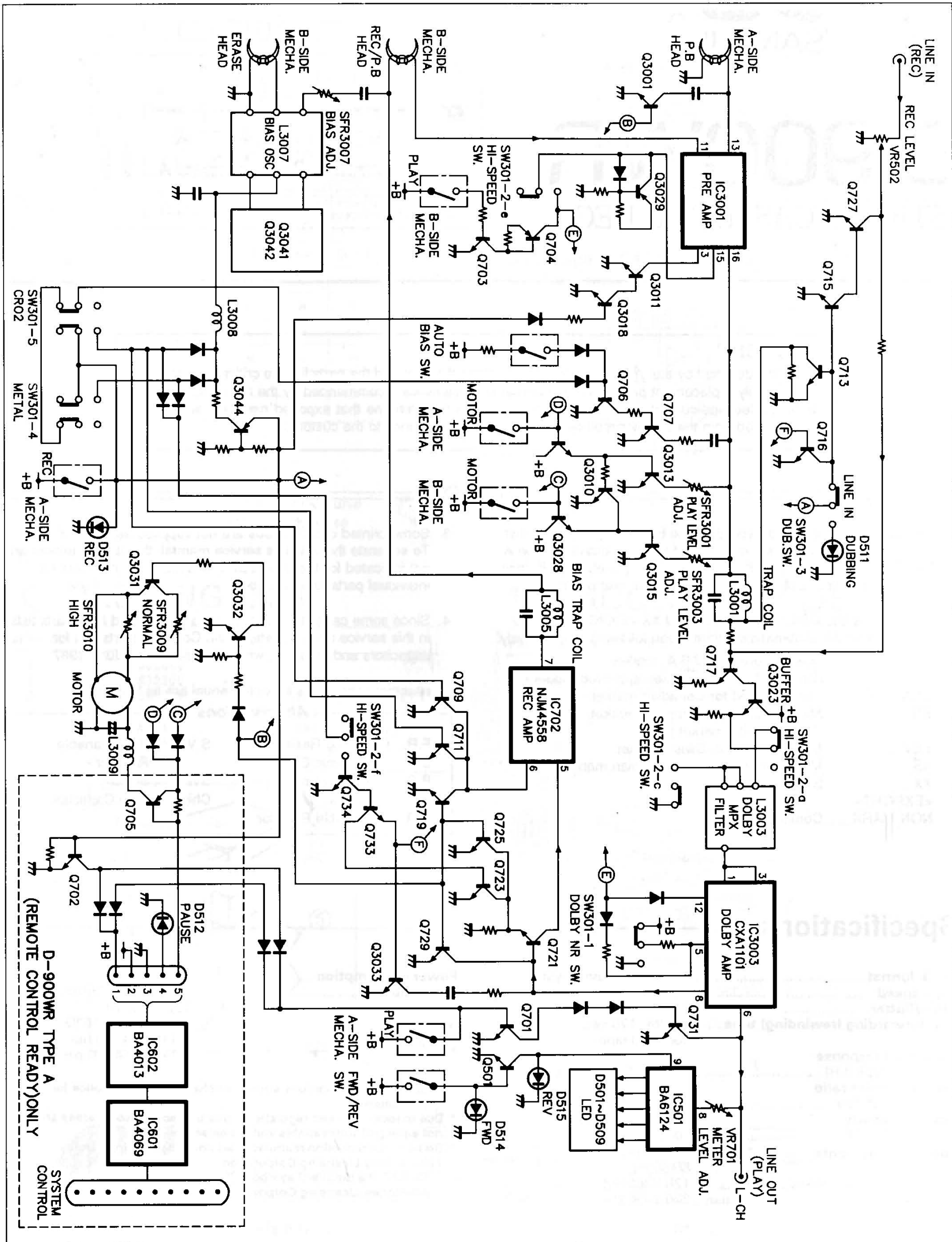

2. ADJUSTMENTS (See Fig. 2-5 Parts Location on page 5)

2-1. Tape Speed Adjustment

- Note:** 1. Use Sansui Test Tape, SCT- 3SK.
(3 kHz signals are recorded on the tape).
2. Connections are shown in Fig. 2-1.

Fig. 2-1

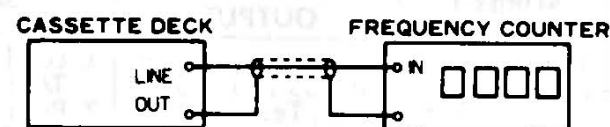

1) Normal Speed Adjustment

STEP	SUBJECT	MEASURE OUTPUT	SETTING	ADJUSTMENT	ADJUST FOR	REMARKS
1.	Normal speed Adj.	LINE OUT. Frequency counter	Playback the TEST TAPE SCT-S3K. B Side Mecha.	Turn the SFR3009 on the Main board (See Fig. 2-5)	3000Hz \pm 30Hz 0Hz	

2) High Speed Adjustment

- Note:** 1. Set the DUBBING switchON
2. Set the NORMAL/HIGH switchHIGH

STEP	SUBJECT	MEASURE OUTPUT	SETTING	ADJUSTMENT	ADJUST FOR	REMARKS
1.	High Speed Adj.	LINE OUT. Frequency counter	1. Short between test point TP3010 and TP3011 (See Fig. 2-5) 2. Play back the TEST TAPE SCT-3SK. A side Mecha.	Turn the SFR3010 on the Main board (See Fig. 2-5)	5400Hz \pm 54Hz 0Hz	

2-2. Playback Adjustment

- Note:** 1. Before this adjustment, clean REC/P.B. head surface.
2. For this adjustment, use Sansui Test Tape, SCT-F10K, and SCT-L400N.
3. Set the Dolby NR switch to OFF.
4. Connections are shown in Fig.2-2.

Fig. 2-2

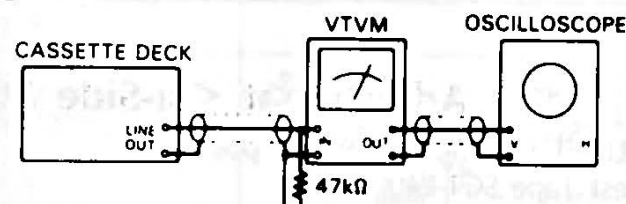
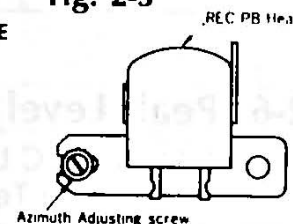

Fig. 2-3



1) a-Side Mecha. Adjustment

STEP	SUBJECT	MEASURE OUTPUT	SETTING	ADJUSTMENT	ADJUST FOR	REMARKS
1.	P.B. Head Adj.	LINE OUT VTVM and Scope	Playback the TEST TAPE SCT-F10K	Adjust the azimuth adjusting screw in Fig. 2-3.	Max. Output both channels.	After this adjustment, lock the screw with paint.
2.	Playback Level Adj.	Same as above	Playback the TEST TAPE SCT-L400N	Adjust each SFR3001(L) and SFR3002(R), Main board	548mV \pm 1dB	See Fig. 2-5

2) b-Side Mecha. Adjustment

STEP	SUBJECT	MEASURE OUTPUT	SETTING	ADJUSTMENT	ADJUST FOR	REMARKS
1.	REC/P.B. Head Adj.	LINE OUT VTVM and Scope	Playback the TEST TAPE SCT-F10K	Adjust the azimuth adjusting screw in Fig. 2-3.	Max. Output both channels.	After this adjustment, lock the screw with paint.
2.	Playback Level Adj.	Same as above	Playback the TEST TAPE SCT-L400N	Adjust each SFR3003(L) and SFR3004(R), Main board.	548mV \pm 1dB	See Fig. 2-5

2-3. Bias Adjustment

- Note:** 1. For, this adjustment, use Sansui Test Tape, SCT-MA.
2. Set the Dolby NR switchOFF
3. REC LEVEL volumeMax.
4. Connections are shown in Fig. 2-1

STEP	SUBJECT	MEASURE OUTPUT	SETTING	ADJUSTMENT	ADJUST FOR	REMARKS
1.	Bias Frequency Adj.	Between Point (A) of CN3004 and GND Frequency Counter.	1. Load the TEST TAPE SCT-MA 2. Push the REC and PLAY button.	Turn the core of L3007 (Main board)	140kHz \pm 3kHz	See Fig. 2-5

2-4. TRAP Coil Adjustment

Note: 1. Connections are shown Fig.2-2.
2. Use Sansui Test Tape SCT-SA.

STEP	SUBJECT	MEASURE OUTPUT	SETTING	ADJUSTMENT	ADJUST FOR	REMARKS
1.	Trap Coil Adj.	Between Test Point TP3003 and TP3005 L-CH, Test Point TP3004 and TP3005 R-CH. Volt meter and Scope.	1. Load the TEST TAPE SCT-SA 2. Push the REC and PLAY button.	Turn the Core of L3005 L-CH, L3006 R-CH. (Main board)	Min. Output both channels.	See Fig. 2-5

2-5. Frequency Response Adjustment <b-Side Mecha. Only>

Note: 1. Connections are shown in Fig. 2-4.
2. Set the Dolby NR switch to be OFF.
3. Use Sansui Test Tape SCT-SA.

Fig. 2-4

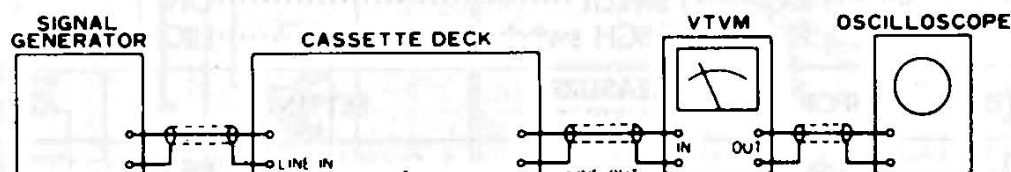

STEP	SUBJECT	INPUT SIGNAL	MEASURE OUTPUT	SETTING	ADJUSTMENT	REMARKS
1.	Frequency Response Adj.	Feed 1kHz 54mV and 10kHz 54mV from S.G. into LINE IN	LINE OUT VTVM and Scope	Load the TEST TAPE SCT-SA. 1. Record the 1kHz and 10kHz signals from S.G. 2. Playback the 1kHz and 10kHz signals, then confirm 10kHz signal level in less than 1kHz signal level $\pm 2\text{dB}$ on VTVM.	1. If not, adjust SFR3007(L) and SFR3008(R), Main board slightly until the 10kHz signal level in less than 1kHz signal level $\pm 2\text{dB}$ on VTVM.	See Fig. 2-5

2-6. Peak Level Meter Adjustment <a-Side Mecha. Only>

Note: 1. Set the REC LEVEL volume to be Max. position.
2. Use Sansui Test Tape SCT-L400.

STEP	SUBJECT	MEASURE OUTPUT	SETTING	ADJUSTMENT	ADJUST FOR	REMARKS
1.	Peak Level Meter Adj.	Peak Level Meter	Playback the TEST TAPE SCT-L400	Adjust each VR701 L-CH and VR702 R-CH. (Main board)	Lighten the 4th LED (+3dB) of Peak Level Meter.	See Fig. 2-5

2-7. Filter Adjustment <b-Side Mecha. Only>

Note: 1. Set the REC LEVEL volume to be Max. position.
2. Connections are shown in Fig. 2-4.

STEP	SUBJECT	INPUT SIGNAL	MEASURE OUTPUT	SETTING	ADJUSTMENT	REMARKS
1.	19kHz Filter Adj.	Feed 19kHz from Audio S.G. into LINE IN	LINE OUT VTVM and Scope.	Push the REC and PLAY button.	Turn the core of L3003 L-CH and L3004 R-CH. Min. Output both channels	See Fig. 2-5

◆ List of Sansui Test Tape

Name of TEST TAPE	Recorded Frequency	Description	Equivalent To
SCT-F40	40 Hz	Playback Frequency Response Check	—
SCT-F1K	1 kHz	High Frequency Equalization Check	—
SCT-F10K	10 kHz	REC/PB Head Adjustment	—
SCT-L400N	400 Hz	Playback Level and Indicator Level Adjustment	—
SCT-S3K	3 kHz	Speed Check and Wow & Flutter Check	—
*SCT-AD (NORMAL)	—	Recording Bias Adjustment	TDK AD
*SCT-SA (HIGH)	—	REC/PB Level Adjustment	TDK SA
*SCT-MA (METAL)	—	Frequency Response Check	TDK MA

•Note: Some reference tapes marked * are not supplied.
As these are equivalent to ones indicated above, please obtain these blank tapes on your side as possible.

Fig. 2-5 Adjustment points on Main board

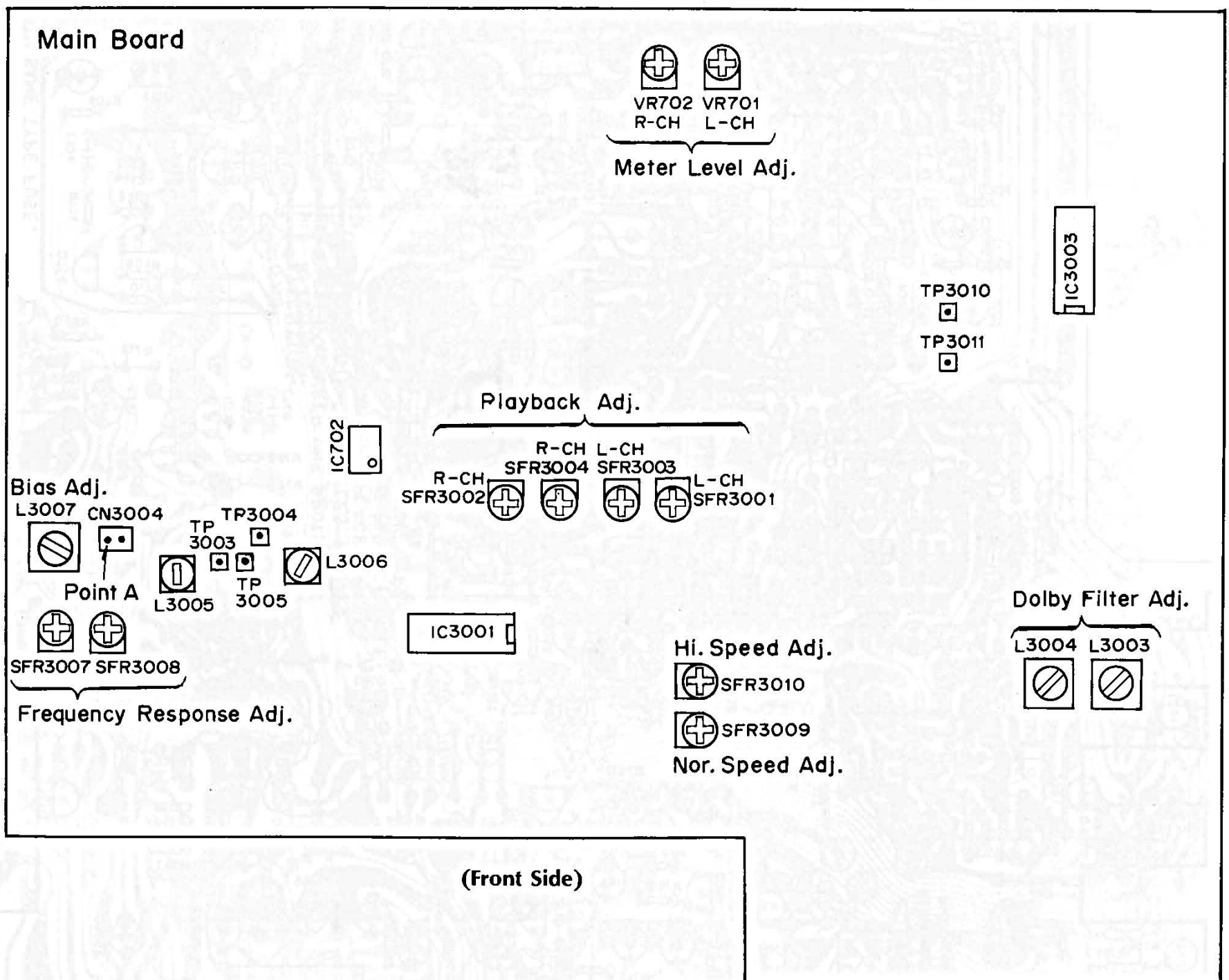

3-2. Level Control & Display Board
Component Side

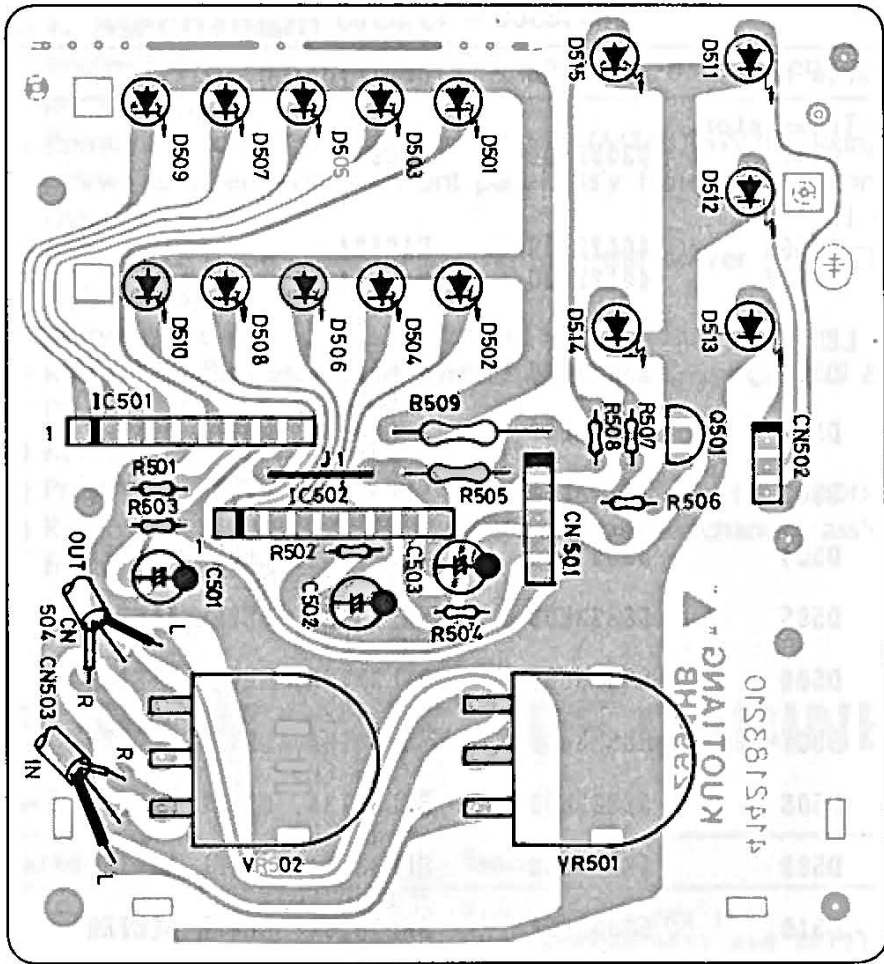

3-5. Power SW. Board
Component Side

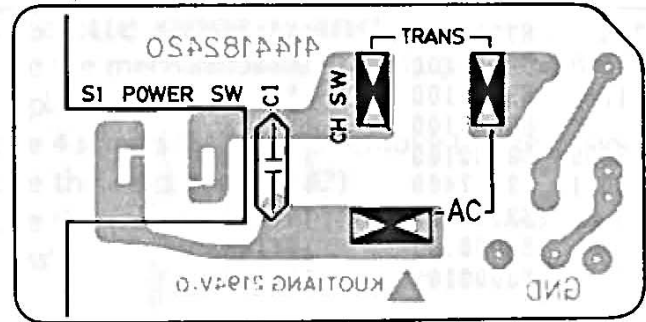

3-6. Change SW. Board (XX,SS)
Component Side

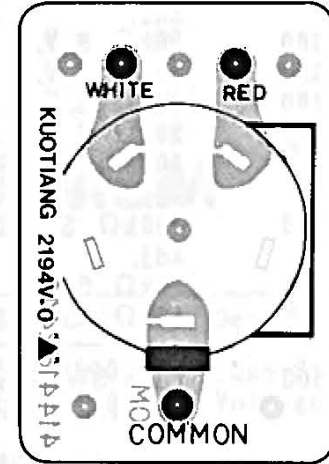

3-3. Remote Control Board (Type A only)
Component Side

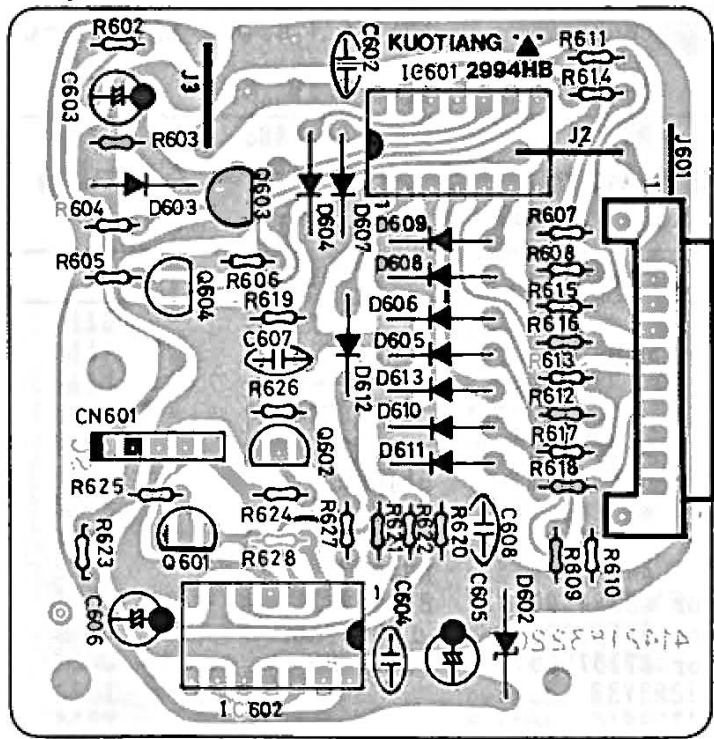

3-4. Power Indicator Board
Component Side

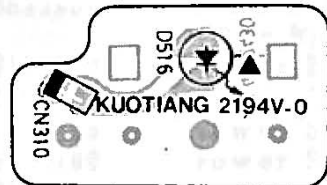

4. PARTS LIST OF BOARD

**4-1. Main Board (Stock No. 58834400 = Type A
58838100 = Type B)**

Parts No.	Stock No.	Description
• Transistor		
Q701	03059501	2SC945
Q702	03059501	2SC945 (Type A)
Q703	03059501	2SC945
Q704	07197001	2SA733
Q705	07206801	2SA952 (Type A)
Q706~716	03059501	2SC945
Q717, 718	58834900	2SC1842
Q719~732	03059501	2SC945
Q733	07197001	2SA733
Q734~736	03059501	2SC945
Q3001~3008	03059501	2SC945
Q3009	07197001	2SA733
Q3010, 3011	03059501	2SC945
Q3013~3016	03059501	2SC945
Q3018	03059501	2SC945
Q3023, 3024	58834900	2SC1842
Q3025~3028	03059501	2SC945
Q3029~3031	07197001	2SA733
Q3032~3034	03059501	2SC945
Q3041, 3042	07206901	2SC2001
Q3044	07197001	2SA733
• IC		
△ IC701	58834700	L7812CV
△ IC702	58834800	MC7812CT
IC3001	58834600	NJM4558DA
IC3003	49317700	TA7784P
	58834500	CXA1101
• Diode		
△ D701~705	03117400	1N4002
D706~709	83000100	1N4148
D710, 711	83000100	1N4148 (Type A)

to be continued

Parts List <Main Board>

Parts No.	Stock No.	Description
D712, 713	83000100	1N4148
D714, 715	03117400	1N4002
D716, 717	83000100	1N4148
D3001	83000100	1N4148
D3004~3009	83000100	1N4148
D3010, 3011	03117400	1N4002
D3012	83000100	1N4148
D3014	83000100	1N4148
D3016	83000100	1N4148
L3001, 3002	58835700	Trap Coil 10 μ H
L3003, 3004	58835600	Dolby MPX Filter
L3005, 3006	58835400	Bias Trap Coil
L3007	58835500	Bias OSC Coil
L3008, 3009	58835800	Motor Choke 470 μ H
vR701, 702	58836400	200k Ω S. V. R., Meter Level Adj.
sFR3001	58836300	50k Ω S. V. R., Play Level Adj.
sFR3002	58836300	50k Ω S. V. R., Play Level Adj.
sFR3003	58836200	20k Ω S. V. R., Play Level Adj.
sFR3004	58836200	20k Ω S. V. R., Play Level Adj.
sFR3007	58836000	100k Ω S. V. R., REC Bias Level Adj.
sFR3008	58836000	100k Ω S. V. R., REC Bias Level Adj.
sFR3009	58836100	10k Ω S. V. R., Motor Speed Adj.
sFR3010	58836100	10k Ω S. V. R., Motor Speed Adj.
sW301	58836500	Push SW., Tape Selector Dubbing, Dolby NR
J701	58836600	4P Terminal, LINE IN/OUT
△ FR301	00120400	15 Ω 1/2W F. R.
C707	58836900	0.022 μ F 25V C. C.
C713, 714	58837200	680pF 50V C. C.
C719, 720	58837400	820pF 50V C. C.
C721, 722	58837300	330pF 50V C. C.
C733, 734	58837200	680pF 50V C. C.
C737, 738	58836800	220pF 50V C. C.
C749, 750	58837500	15pF 50V C. C.
C3001~3004	58836800	220pF 50V C. C.
C3008~3011	58837200	680pF 50V C. C.
C3035, 3036	58836800	220pF 50V C. C.
C3041, 3042	58837000	120pF 50V C. C.
C3047	58835900	0.056 μ F 200V P. C.
C3053~3055	58836900	0.022 μ F 25V C. C.
C3072, 3073	58837400	820pF 50V C. C.
C3085, 3086	58836800	220pF 50V C. C.
C3089, 3090	58837100	100pF 50V C. C.

4-2. Power Switch Board

Parts No.	Stock No.	Description
△ S1	58873500	Push Switch, Power
△ C1	46371700	4700pF 400V C. C.

4-3. Voltage Selector Switch Board (xx,ss)

Parts No.	Stock No.	Description
△ S2	58873400	Voltage Selector Switch

4-4. Power Indicator Board

Parts No.	Stock No.	Description
D516	58833300	SEL3913K, POWER IND.

4-5. Level Control & Display Board

(Stock No. 58833500 = Type A
58838300 = Type B)

Parts No.	Stock No.	Description
• Transistor		
Q501	03059501	2SC945
• IC		
IC501	46129100	BA6124
IC502	46129100	BA6124
• LED		
D501	58833600	SEL3813A, LEVEL METER +6dB (L)
D502	58833600	SEL3813A, LEVEL METER +6dB (R)
D503	58833600	SEL3813A, LEVEL METER +3dB (L)
D504	58833600	SEL3813A, LEVEL METER +3dB (R)
D505	58833600	SEL3813A, LEVEL METER 0dB (L)
D506	58833600	SEL3813A, LEVEL METER 0dB (R)
D507	58833600	SEL3813A, LEVEL METER -5dB (L)
D508	58833600	SEL3813A, LEVEL METER -5dB (R)
D509	58833600	SEL3813A, LEVEL METER -10dB (L)
D510	58833600	SEL3813A, LEVEL METER -10dB (R)
D511	48841100	SEL3210S, REC
D512	48841200	SEL3910A, PAUSE (Type A)
D513	48841100	SEL3210S, DUBBING
D514	48841200	SEL3910A, FWD
D515	48841200	SEL3910A, REV
vR501	58833800	50k Ω A V. R. REC LEVEL R-CH
vR502	58833800	50k Ω A V. R. REC LEVEL L-CH
△ R509	00119700	10 Ω 1/2W F. R.

4-6. Remote Control Board (Type A only)

(Stock No. 58833900 = Type A only)

Parts No.	Stock No.	Description
• Transistor		
Q601~604	03059501	2SC945
• IC		
IC601	48063900	BU4069UB
	or 58834000	BA4069
	or 58834200	μ PD4069BC
	or 07107600	TC4069UBP
IC602	48072400	BU4013B
	or 58834100	BA4013
	or 48053600	μ PD4013BC
	or 07107500	TC4013BP
• Diode		
D601, 602	58836700	RD5.1EB
D603~613	83000100	1N4148
J601	58834300	10P Terminal, SYSTEM CONTROL



5. MAIN PARTS REPLACEMENT (See Exploded of Cabinet on Page 10)

5-1. Mechanism Ass'y

- 1) Remove 4 screws (M36a) and 2 screws (M10a) to remove the bonnet (M40).
- 2) Remove 5 screws (M10b) and 1 screw (M14b)(SW301 fixing screw) and remove the front panel ass'y from the bottom chassis.
- 3) Remove 2 screws (M14c) and remove the power SW. PCB ass'y (M23).
- 4) Remove the REC LEVEL VR. knob (M4) and nut.
- 5) Remove 4 screws (M14d) and remove the Level Control & Display PCB ass'y (M13).
- 6) Remove the connector belt. (M21).
- 7) Press the STOP/EJ button to open the L and R cassette doors.
- 8) Remove 7 screws (M14e) and remove the mechanism ass'y from the front panel ass'y (001).

5-2. Cassette door L and R

- 1) Remove the mechanism ass'y (M33). (Refer to the mechanism ass'y replacement on the left.)
- 2) Remove 4 screws (M14f) and remove the gear damper (M15).
- 3) Remove the eject spring (M2).
- 4) Remove the cassette door L (M1) and R (M3) from the front panel ass'y.

6. PARTS LIST OF CABINET & MECHANISM

6-1. Cabinet

Parts No.	Stock No.	Description
001	58829800	Front Panel Ass'y (includeing M11 and M12)
M1	58831000	Cassette Door (L)
M2	58831600	Eject Spring
M3	58831100	Cassette Door (R)
M4	58830800	Knob, REC Level (L)/(R)
M5	58833000	Knob, Tape Selector, Dubbing, Dolby NR
M6	58831300	Indicator Window (Type A)
	58838000	Indicator Window (Type B)
M7	58830900	Power Lens
M8	58830700	Knob, Power
M9	58873400	Spring, Power Knob
M11	27486200	Badge
M13	58833500	Level Control & Display PCB Ass'y (Type A)
	58838300	Level Control & Display PCB Ass'y (Type B)
M15	58831400	Gear Damper
M17	58831200	Mirror
M19		Power Indicator PCB Ass'y
M20	58831900	Tape Counter
M21	58831500	Counter Belt
M23		Power Switch PCB Ass'y
M25	58832000	Button, REC
M26	58832100	Button, PLAY
M27	58832200	Button, REW
M28	58832300	Button, F, FWD
M29	58832400	Button, STOP/EJ
M30	58832500	Button, PAUSE
M31	58832700	Button, REVERSE/MODE
M32	58832600	Button, DIRECTION
M33		Cassette Mechanism Ass'y
M37	58829900	Leg
M40	58830000	Bonnet
M41	58834400	Main PCB Ass'y (Type A)
	58838100	Main PCB Ass'y (Type B)
M46		Change Switch PCB Ass'y <XX, SS>
M48	58833900	Remote Control PCB Ass'y (Type B)
M52	39106000	Strain Relief
△ M53	38004700	Power Supply Cord <XX>
△	49356400	Power Supply Cord <SS>
△	38004700	Power Supply Cord <UL, CSA>
△	49299300	Power Supply Cord <EU, SEV>
△ T1	58833100	Power Transformer <XX, SS>
△	58837700	Power Transformer <UL, CSA>
△	58837900	Power Transformer <EU, SEV>

Parts No.	Stock No.	Description
△ S1	58873500	Push Switch, Power
△ S2	58833400	Voltage Selector Switch
△ F701	46201600	AC Fuse 1.25A 125V <UL, CSA>
△	07184800	AC Fuse 1.25A 250V <XX, SS, EU, SEV>

Note: Parts without Stock Nos, are not supplied even parts names are listed in the Parts List.

6-2. Mechanism

Parts No.	Stock No.	Description
1	37118200	Base Ass'y
2	37118300	Switch Actuator
3	37118400	Push Button Actuator
10	37118500	Spring
11	37118600	Pause Lever
12	37118700	Spring
13	37118800	Pause Stopper
14	37118900	Spring (A)
15	37119000	Chassis Ass'y
16	37119100	Spring
17	37119200	Spring
19	37119300	E Kick Lever
20	37119400	PR Stopper
21	37119500	Spring
22	37119600	Spring
23	37119700	Leaf Switch
24	37119800	Leaf Switch
27	37119900	Head Base
28	58600600	Spring
29	37120000	Spring
30	37120100	Spring
34	58672300	Spring
35	37120200	Pinch Roller Arm Ass'y
37	37120300	Sensing Lever
38	37120400	RF Clutch Ass'y
39	37120500	RF Belt
40	37120600	REC Arm
41	37120700	P Arm Collar
44	37120800	Flywheel Ass'y
45	37120900	Spring
47	37121000	Cam Gear
49	37121100	FF Gear
50	37121200	Spring
51	37121300	Supply Reel Ass'y

to be continued

D-900WR

Parts List <Mechanism>

Parts No.	Stock No.	Description
52	37121400	Take UP Reel Ass'y
53	37121500	Sensor
56	58602600	Motor Rubber
57	58602700	Motor Collar Screw
59	37121600	Main Belt
62	37121700	Eject Slide Lever
63	37121800	Record Safety Lever
64	37121900	Spring
65	37122000	Fram Bracket
66	58839200	REC/PLAY Head
67	58839300	ERASE Head
69	37122300	Operation Lever
70	58594600	Button Lever Shaft
73	58605400	Screw, M2×5
74	37122400	Screw, M2×4.5
77	37122500	Screw, M2×3
78	58605800	Screw, M2×7
79	37122700	Screw, M2×9
80	37131200	Screw, M2×3
81	37122800	Screw, M2×7.5
82	58605300	Screw, M2×3
83	37122900	Washer, 1.2×3.8×0.3
84	37123000	Washer, 1.45×3.8×0.5
85	37123100	Washer, 2×3.5×0.3
302	58589800	Pause Lever
303	58589900	Spring
304	37129900	Spring
305	37123200	Dir. SW. Bracket
306	37123300	H. W. Terminal Plate
307	37123400	Wire Clump
308	37123500	H. P. Collar
310	37123600	Spring
311	37123700	Spring
314	37123800	Head Mount
315	37123900	Holder
316	37124000	Pinion Gear
317	37124100	H Turn Over Gear
318	37124200	Head Slide Plate
319	37124300	Head Spring Plate
320	37124400	Spring
321	37124500	H Shield Plate
322	37124600	Spring
323	37124700	Spring
324	37124800	Spring
325	37124900	Screw Holder
326	37125000	Spring (D)
327	58839400	PLAY/BACK Head
330	37125200	Flywheel Ass'y
332	37125300	P. K. Collar Screw (A)
333	37125400	Main Belt
334	37125500	Eject Slide Lever
335	37125600	Spring
343	37125700	Spring
344	37125800	Spring
345	37125900	Spring
346	37126000	Spring
351	37126100	Spring
352	37126200	Spring
353	37126300	Button Base Ass'y
354	37126400	Spring
355	37126500	FF Control Arm
356	37126700	Spring
358	37126800	Spring
359	37126900	Leaf Switch
364	37127000	Reel Ass'y
365	37127100	SUB Chassis Ass'y
366	37127200	RC Arm
367	37127300	Auto Control Arm (F)
368	37127400	Auto Control Arm (R)
369	37127500	Control Arm Collar
371	37127600	Leaf Switch
372	37127700	Auto Lever (F)
373	37127800	Spring
374	37127900	Spring, Stopper
375	37128000	Auto Lever (R)
376	37128100	Spring

Parts No.	Stock No.	Description
378	37128200	Turn Over Arm
379	37128300	Spring
381	37128400	Leaf Switch
382	37128500	T Gear Arm (F) Ass'y
383	37128600	Spring
384	37128700	T Cam Gear (F)
385	37128800	T Gear Arm (R) Ass'y
386	37128900	Spring
387	37129000	T Cam Gear (R)
389	37129100	FF Gear
390	37129200	Spring
391	37129300	FF Gear Arm Collar
394	37129400	Pinch Roller (F) Ass'y
395	37129500	Pinch Roller (R) Ass'y
397	37129600	Operation Lever
399	58603600	Button Lever Shaft
401	37129700	P Kick Lever (B)
402	37129800	P Kick Lever (A)
403	37125300	P.K. Collar Screw (A)
404	37130000	P.K. Collar Screw (B)
405	37130100	Spring
408	37130200	Motor Pulley
410	37130300	Anti-Vibration Felt Mat
411	37130400	Anti-Vibration Felt Mat
412	58839500	Motor
415	37130500	Screw, M2×3
416	37130600	Screw, M2×4
417	58596400	Screw, M2×6
418	37130700	Screw, M1.7×3
419	37130800	Washer, 2.1×5×0.5
420	37130900	Screw, M2×4
421	37131000	Screw, M1.7×4
422	37131100	Screw, M2×12
423	37123100	Washer, 2×3.5×0.3
424	37131300	Washer, 2.1×3×0.3
425	37131400	Washer, 1.45×4×0.5
426	58606500	Washer, 1.2×3×0.25
427	37131500	Washer, 1.2×3.7×0.4
428	37131600	Washer, 3×8.5×0.13
429	37131700	Screw, M1.7×8.5
430	37131800	Screw, M2×9
431	58605500	Screw, M2×5
432	37131900	Washer, 1.75×4×0.3
433	37132000	Washer, 2.8×6×0.5
434	37132100	Screw, M2×4
437	58606400	E-Ring S2.0
438	37132200	Lug Plate
439	37126600	Cord Clamp

7. EXPLODED VIEW OF CABINET & MECHANISM

7-1. Cabinet Exploded View

● Though every part included in Cabinet is numbered in exploded view, parts unlisted in the parts list are not supplied.

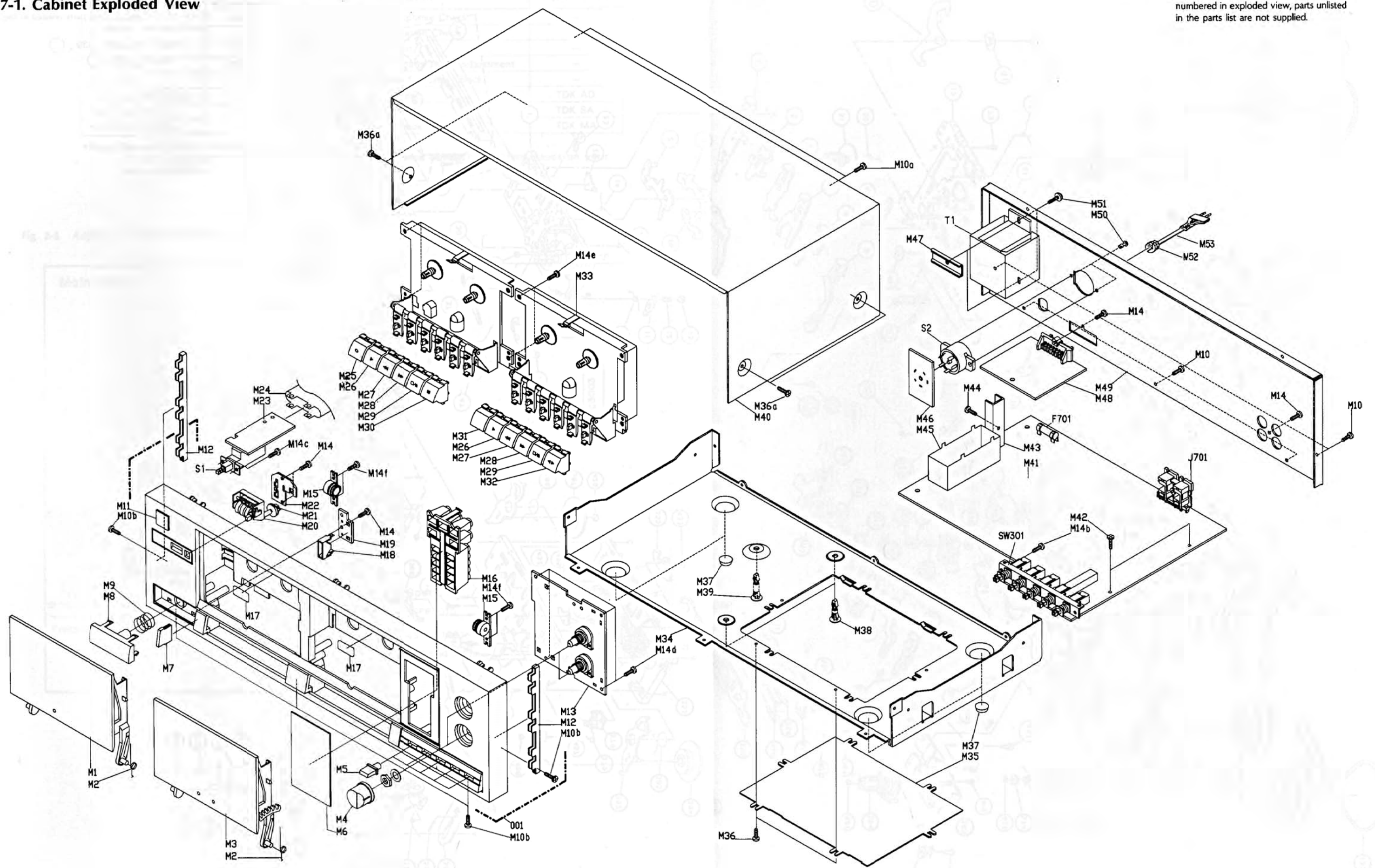

7-2. Mechanism Exploded View

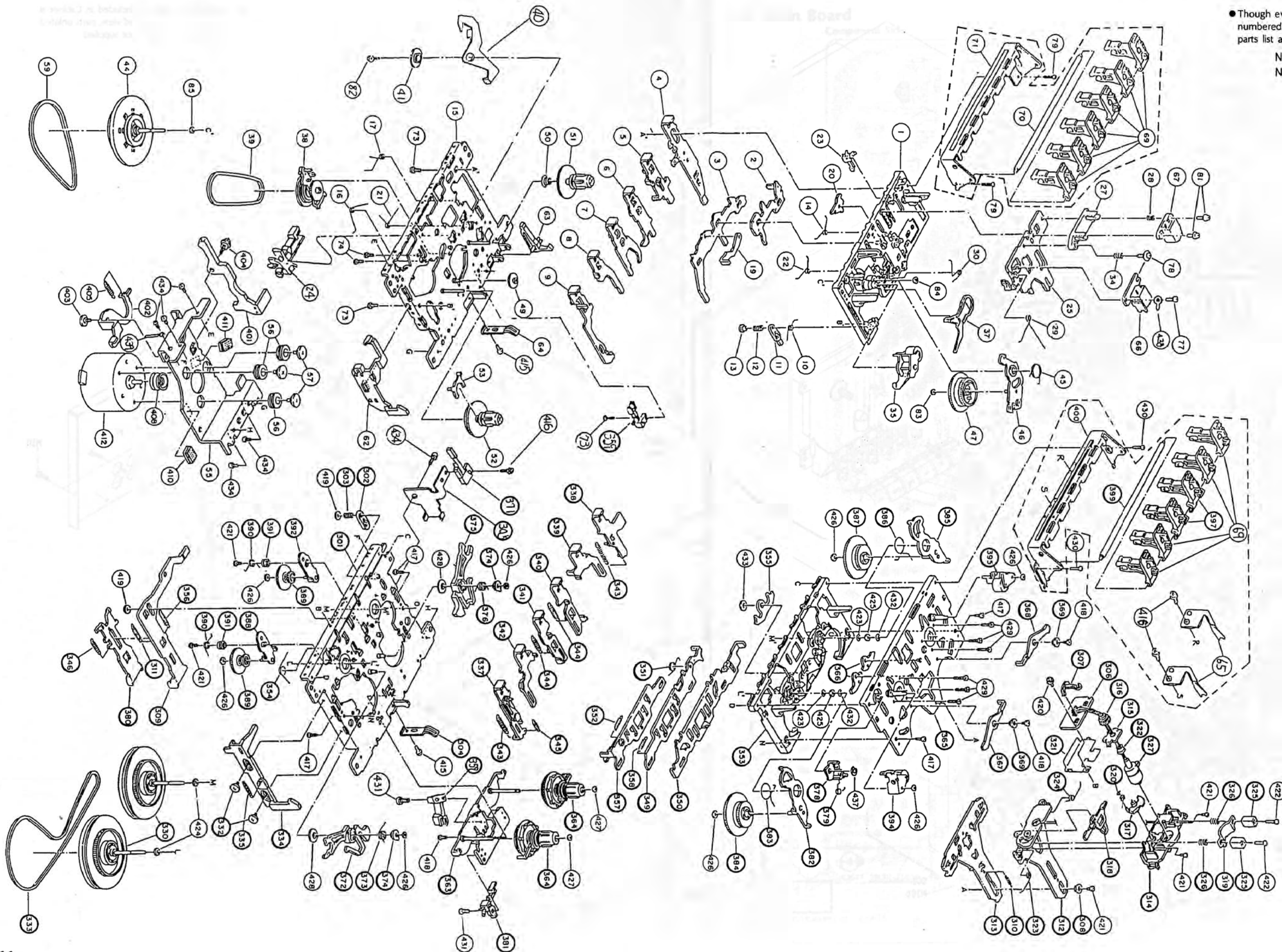

● Though every part included in mechanism ass'y is numbered in exploded view, parts unlisted in the parts list are not supplied.

No.1 - 85, 401 - 439 : ○

No.301 - 399 : ○

8. SCHEMATIC DIAGRAM 8-1. D-900WR (Type A)

• Design and specifications subject to change without notice for improvement.
 • La présentation et les spécifications sont susceptibles d'être modifiées sans préavis par suites d'améliorations éventuelles.
 • Änderungen, die dem technischen Fortschritt dienen, bleiben vorbehalten.

CXA1101
 TA7784P
 NJM4558DA
 BU4013B
 BA4013
 PD4013BC
 TC4013BP
 BU4069UB
 BA4069
 PD4069BC
 TC4069UBP

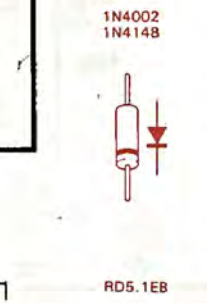
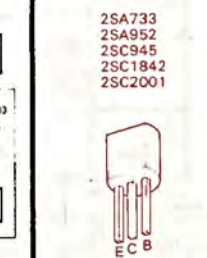
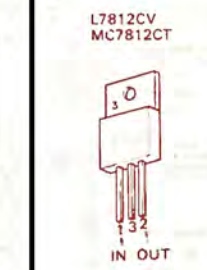
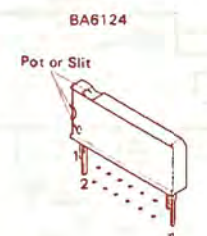
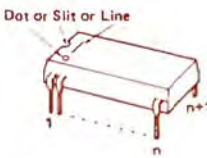
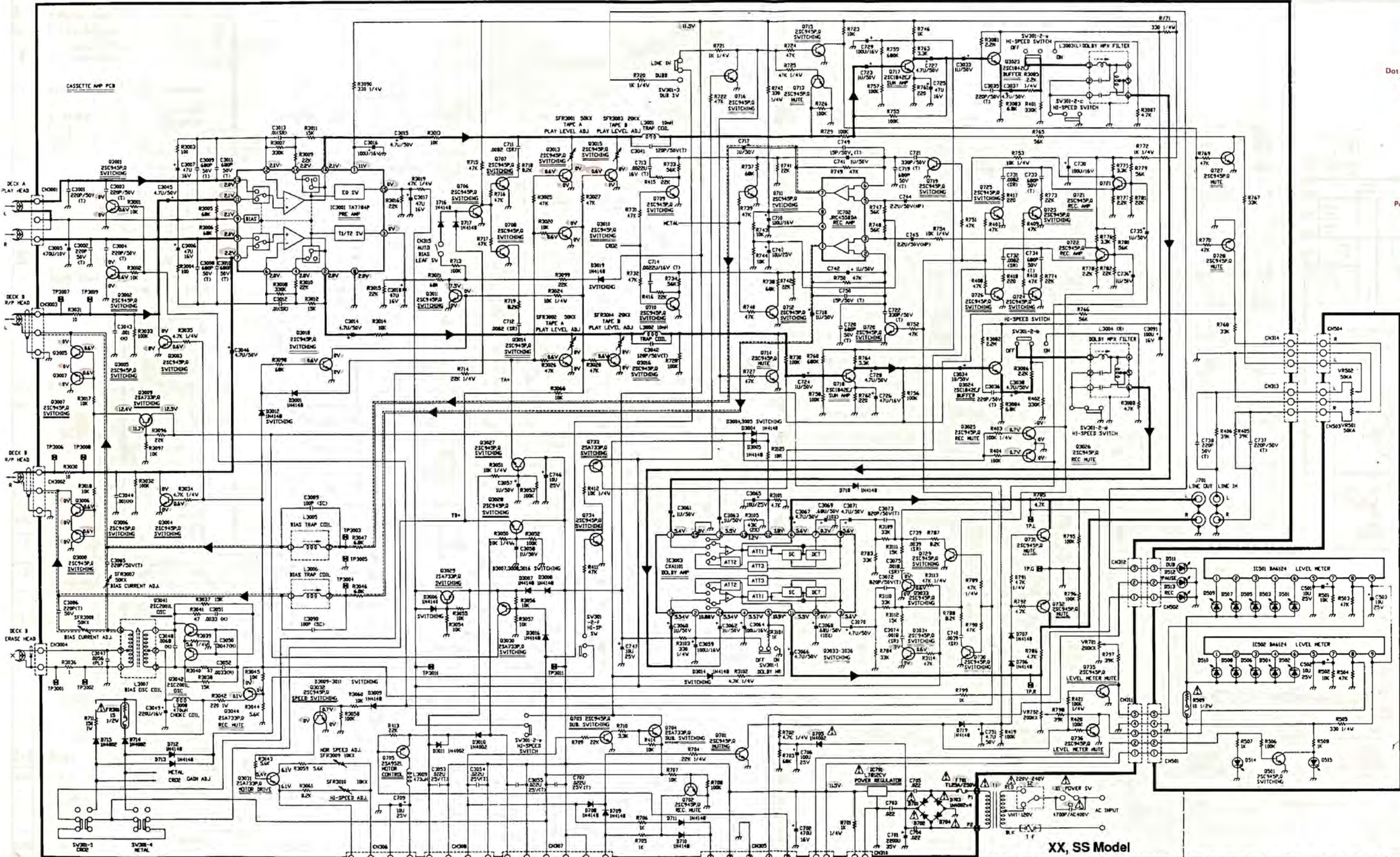

⚠ Safety Part.
 Use only replacement parts recommended by the manufacturer.

RESISTORS
 Are in ohms, 1/6 Watts, 25% Tolerance
 Unless Otherwise Noted, x: k Ω, M: M Ω
CAPACITORS
 Are in μF, Unless Otherwise Noted. P: pF
ELECTROLYTIC CAPACITORS
 Capacitance (μF)/VOLT (V)
 Each D.C Voltage shows the nominal value
 in volts during recording.

SYMBOL
 (C) Ceramic Capacitor
 (T) Ceramic (Temperature Compensation)
 (SK) Semi Conductor Capacitor
 (M) Mylar Film Capacitor
 (PL) Polypropylene Film Capacitor
 (NP) Non-Polar Capacitor

— PLAY SIGNAL LINE
 - - - REC SIGNAL LINE

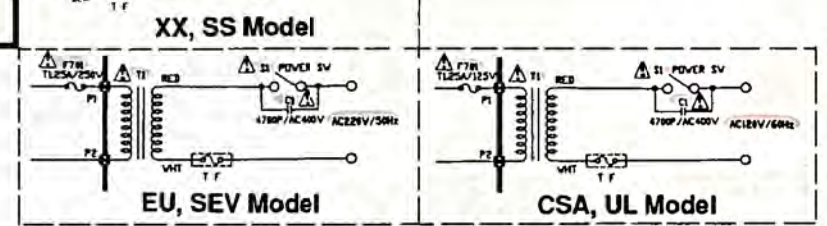

1

2

3

4

5

8-2. D-900WR (Type B)

• Design and specifications subject to change without notice for improvement.
 • La présentation et les spécifications sont susceptibles d'être modifiées sans préavis par suites d'améliorations éventuelles.
 • Änderungen, die dem technischen Fortschritt dienen, bleiben vorbehalten.

- CXA101
- TA7784P
- NJM4558DA
- BU4013B
- BA4013
- PD4013BC
- TC4013BP
- BU4069UB
- BA4069
- PD4069BC
- TC4069UBP

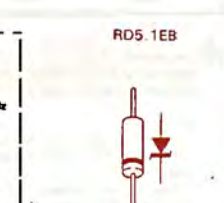
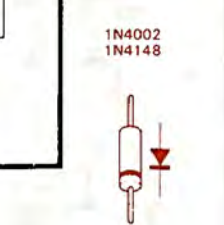
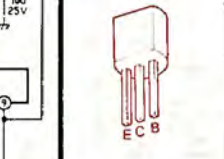
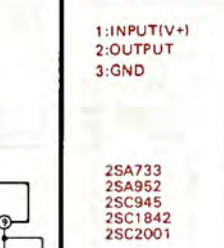
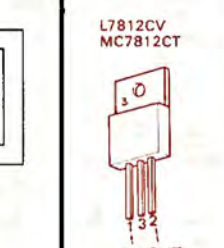
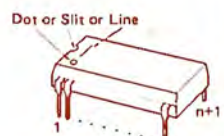
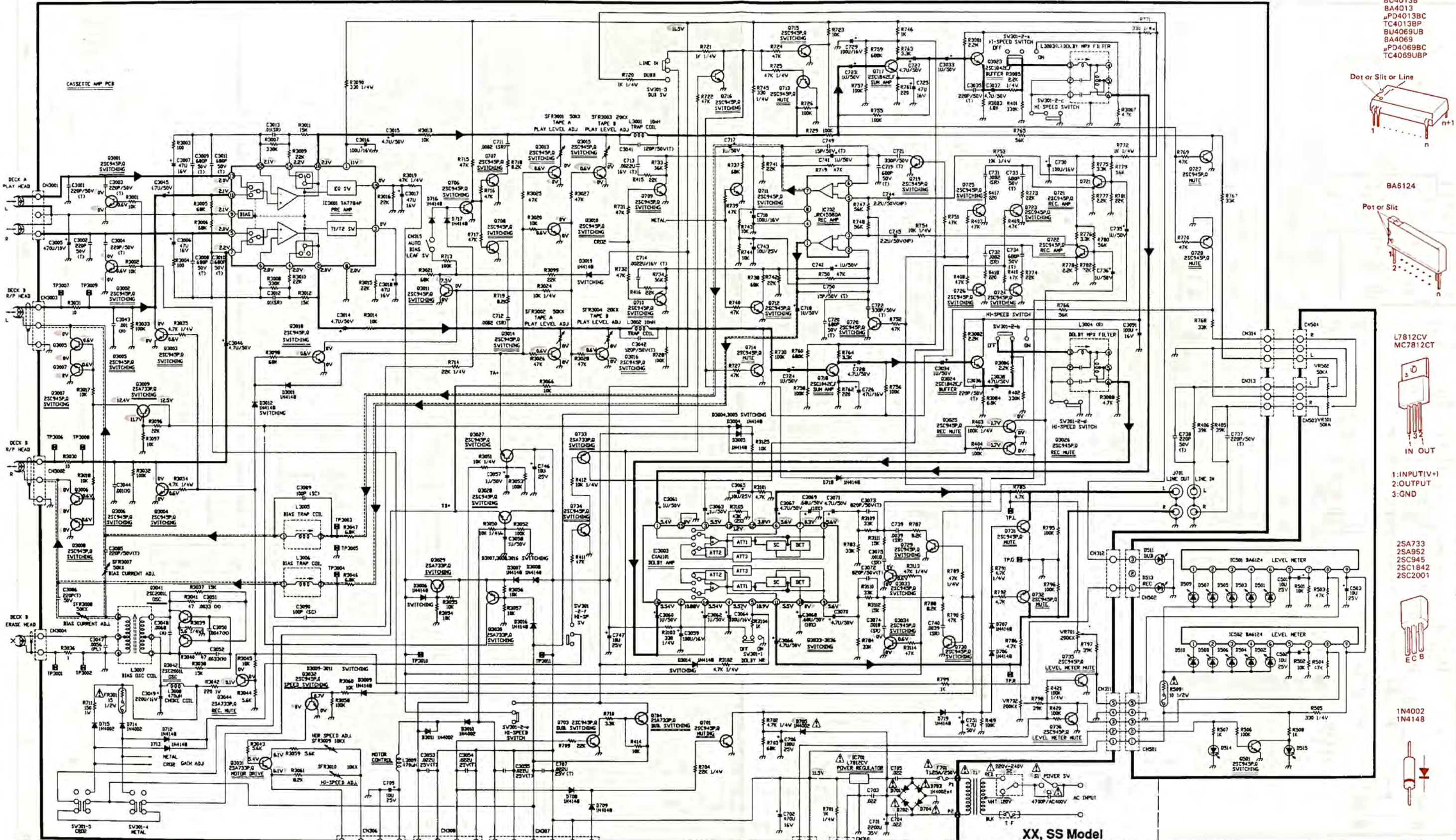

⚠ is Safety Part.
 Use only replacement parts recommended by the manufacturer.

RESISTORS
 Are in ohms, 1/6 Watts, ±5% Tolerance
 Unless Otherwise Noted. k: k Ω, M: M Ω
CAPACITORS
 Are in μF, Unless Otherwise Noted. P: pF
ELECTROLYTIC CAPACITORS
 Capacitance (μF)/VOLT(V)
 Each D.C Voltage shows the nominal value
 in volts during recording.

SYMBOL
 (C) Ceramic Capacitor
 (T) Ceramic (Temperature Compensation)
 (SR) Semi Conductor Capacitor
 (M) Mylar Film Capacitor
 (PL) Polypropylene Film Capacitor
 (NP) Non-Polar Capacitor

————— PLAY SIGNAL LINE
 - - - - - REC SIGNAL LINE

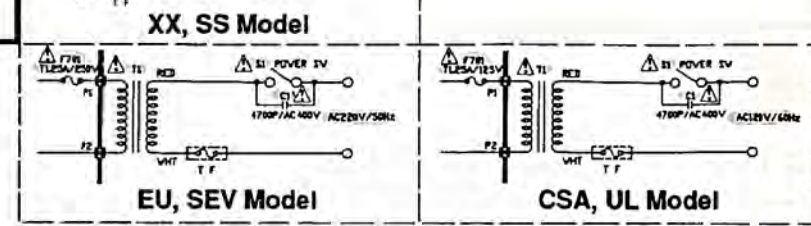

8-3. Remote Control (Type A only)

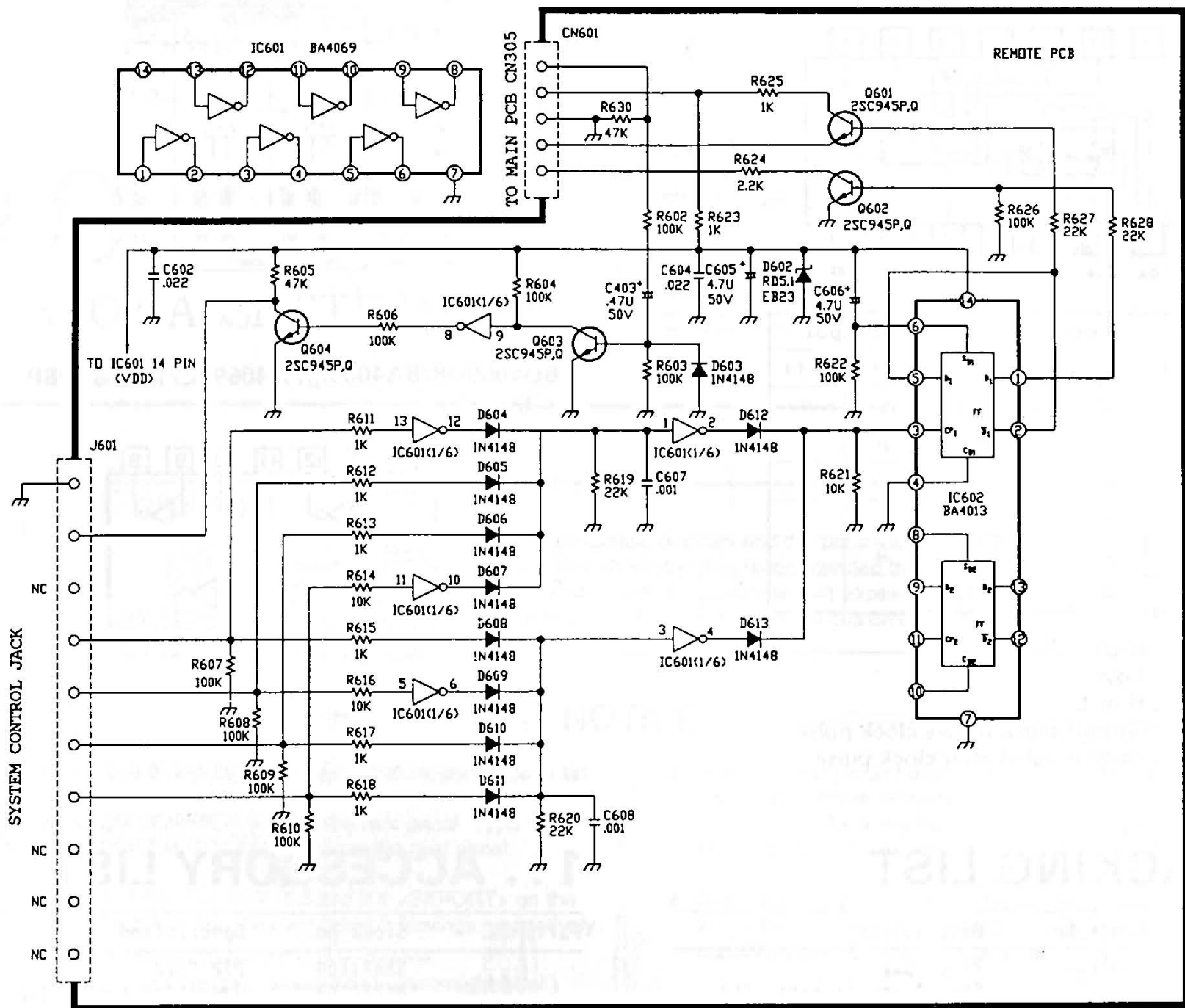

9. INTERIOR BLOCK DIAGRAM OF IC

● CXA1101 <Dolby Noise Reduction>

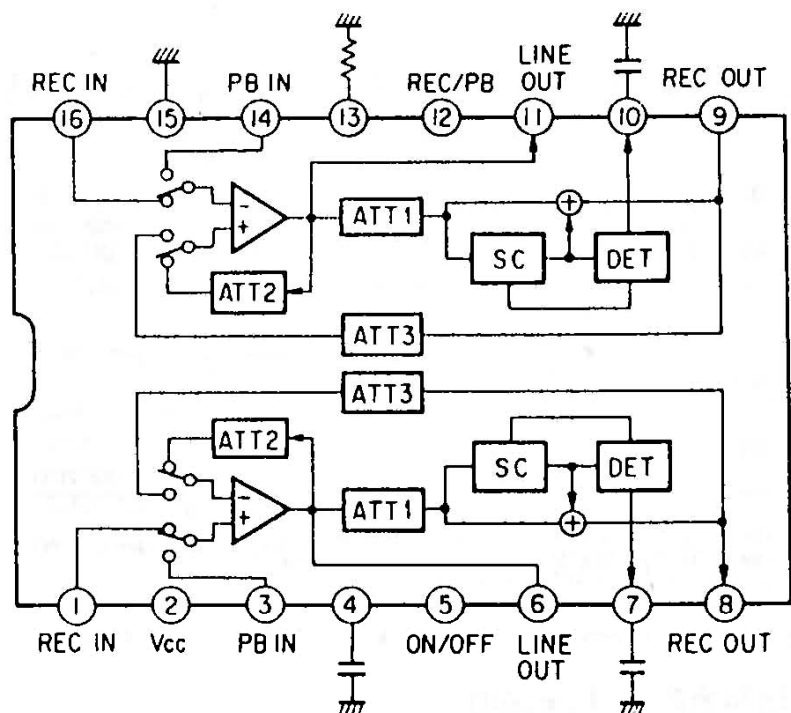

ATT: Attenuator
SC: Side Chain
DET: Detector

● BA6124 <LED Drive>

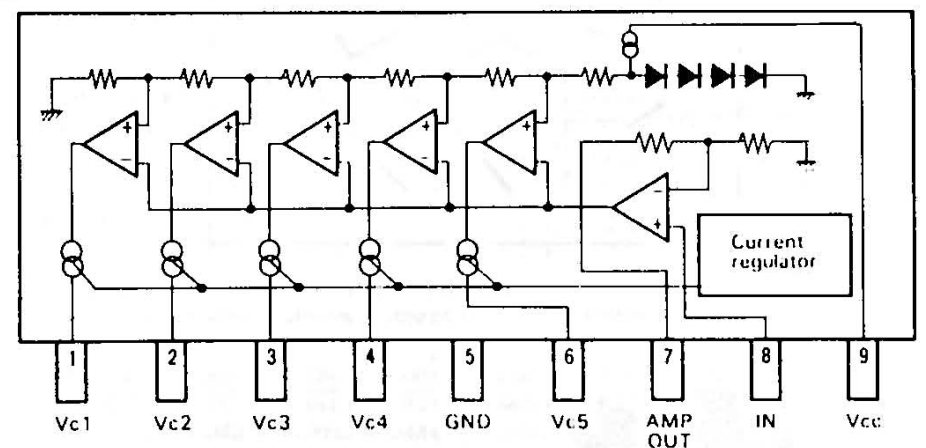

● BU4013B/BA4013/ μ PD4013BC/TC4013BP
 <Flip Flop 2>

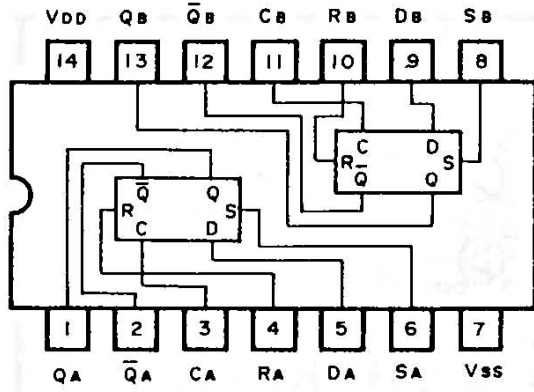

Input				Output	
CLOCK	DATA	SET	RESET	Q _{n+1}	Q̄ _{n+1}
	L	L	L	L	H
	H	L	L	H	L
	X	L	L	Q _n	Q̄ _n
X	X	L	H	L	H
X	X	H	L	H	L
X	X	H	H	L	L

H : High
 L : Low
 X : H or L
 Q_n : Output signal before clock pulse
 Q_{n+1} : Output signal after clock pulse

● NJM4558DA <OP AMP>

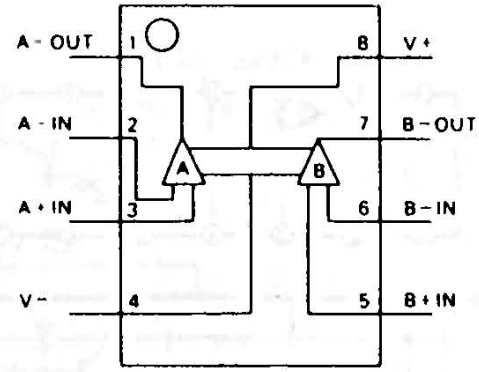

● BU4069UB/BA4069/ μ PD4069BC/TC4069UBP
 <Inverter>

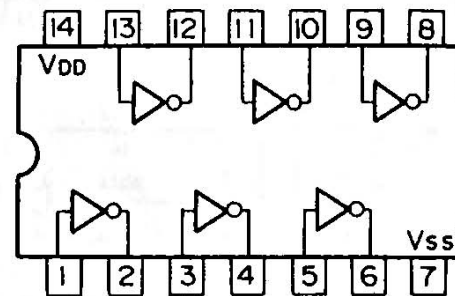

10. PACKING LIST

Parts No.	Stock No.	Description
1	27306000	Vinyl Bag
2	58830300	Styrofoam Packing, (L)
3	58830300	Styrofoam Packing, (R)
4	58830500	Carton Plate
5	58830400	Carton Case (Type A)
	58873600	Carton Case (Type B)
6	58830600	Soft sheet

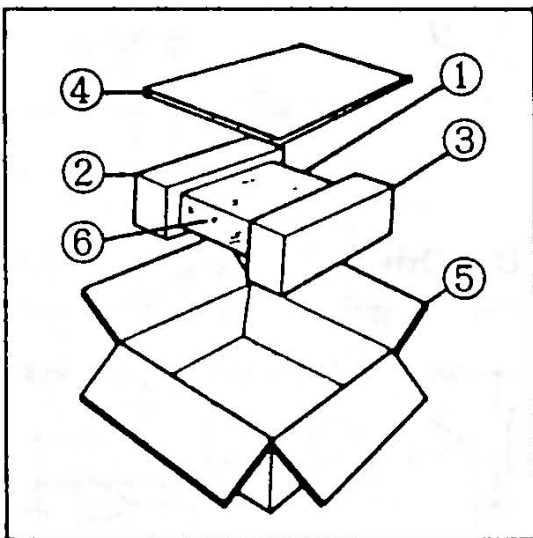

11. ACCESSORY LIST

Parts No.	Stock No.	Description
	58884100	PJP Cord
	58830100	Operating Instruction



SANSUI ELECTRIC CO., LTD.:
 SANSUI ELECTRONICS CORPORATION:
 SANSUI ELECTRONICS G.M.B.H.:

山水電気株式会社

14-1, Izumi 2-chome, Sugunami-ku Tokyo 168 Japan
 PHONE: (03) 324-8891/TELEX: 232-2076 (International Division)
 1250 Valley Brook Ave. Lyndhurst, N.J. 07071 U.S.A.
 17150 South Margay Ave. Carson, California 90746 U.S.A.
 Paul Ehrlich Strasse 8, 6074 Rödermark 2, West Germany

東京都杉並区和泉2-14-1(〒168)

(SM2-171)

Printed in Japan (1990.03.P)

<Stock No. 36551800>