

SERVICE MANUAL

COMPU-REVERSE CASSETTE DECK

SANSUI D-905R

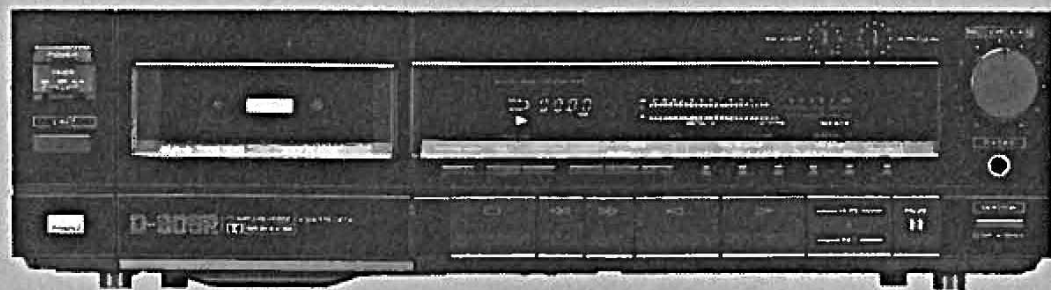

CAUTION

1. Parts identified by the Δ symbol on the schematic diagram and the parts list are critical for safety. Use only replacement parts that have critical characteristics recommended by the manufacturer.
2. Make leakage-current or resistance measurements to determine that exposed parts are acceptably insulated from the supply circuit before returning the appliance to the customer.

•SPECIFICATIONS

Track format	4-track/2-channel system
Tape speed	4.8 cm/sec.
Heads (3-head configuration)	
Rec/pb head	Dioxide titanium coating HIGH-Bs ferrite
Erase head	Double-gap HIGH-Bs ferrite
Motor	Capstan: Electronically Controlled DC Motor
	Reels: DC Motor
Wow/flutter	0.034% max (WRMS) $\pm 0.7\%$ W.Peak
Fast forwarding (rewinding) time	Approx. 85 sec. (for C-60 tape)
Frequency response (—20 VU recording/playback)	
Normal tape (LH)	20 to 18,000 Hz (30 to 17,000 Hz ± 3 dB)
Chrome tape	20 to 20,000 Hz (30 to 18,000 Hz ± 3 dB)
Metal tape	20 to 21,000 Hz (30 to 19,000 Hz ± 3 dB)
Signal to noise ratio (recording/playback with metal tape) (3% T.H.D.)	
DOLBY NR OFF	Better than 60 dB
DOLBY-B NR ON	Better than 68 dB
DOLBY-C NR ON	Better than 74 dB
Erasure factor (Metal Tape)	more than 65 dB at (1 kHz)
Recording bias frequency	85 kHz
Input sensitivity/impedance	
LINE IN (REC)	80 mV/50 kohms
Power requirements	110~120V/220~240 V 50/60 Hz
	For U.S.A. and Canada
	120V (60 Hz)
Power consumption	32 watts
Dimensions	435 mm (17-1/8")W 115 mm (4-1/2")H 282 mm (11-1/8")D
Weight	5.4 kg (11.9 lbs) net
	For U.S.A. and Canada
	4.9 kg (10.8 lbs) net

- Design and specifications subject to changes without notice for improvements.
- Noise reduction system manufactured under license from Dolby Laboratories Licensing Corporation. "Dolby" and the double D symbol are trade marks of Dolby Laboratories Licensing Corporation.



SANSUI ELECTRIC CO., LTD.

CAUTION

1. The symbols, UL, CSA, SA, BS, UK, EU, AS and XX on the parts list and the schematic diagram mean followings respectively.

UL..... Manufactured for U.S.A market.
(Underwriters Laboratories approved model.)
CSA..... Manufactured for Canadian market.
SA..... Manufactured for South African market.
BS, UK Manufactured for United Kingdom market.
EU Manufactured for European market.
AS..... Manufactured for Australian market.
XX..... Standard Version.
NON MARK Common Parts.

2. Some printed circuit boards are not supplied as the assembled. To separate these in this service manual, the stock No's are not indicated at the ends of the board names. However, the individual parts on the circuit boards are provided by orders.
3. Since some of capacitors and resistors are omitted from parts lists in this service manual, refer to the Common Parts List for capacitors & resistors, which was issued on February 1983.

1. BLOCK DIAGRAM

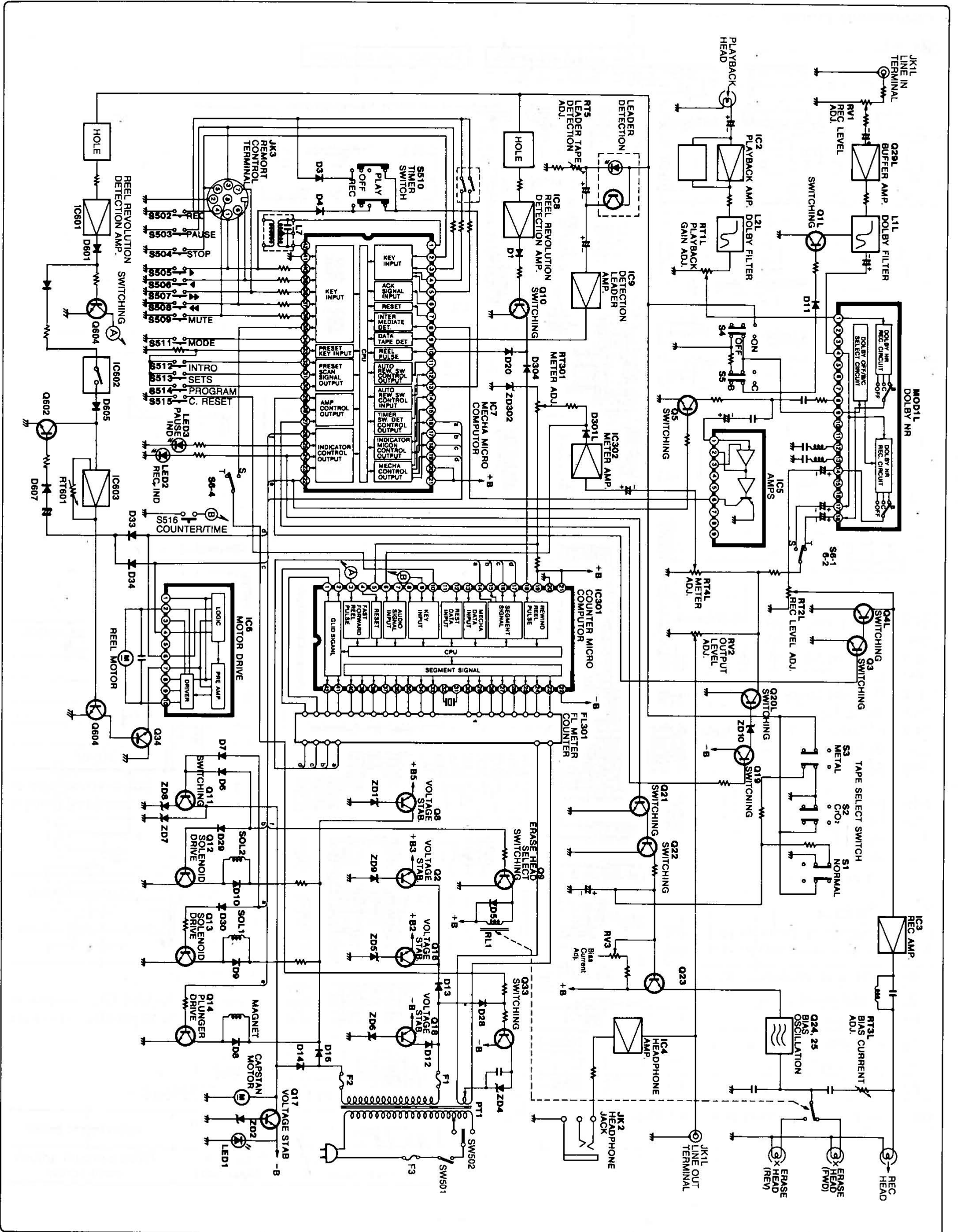

2. ADJUSTMENTS

• Adjustment Points

Fig. 2-1

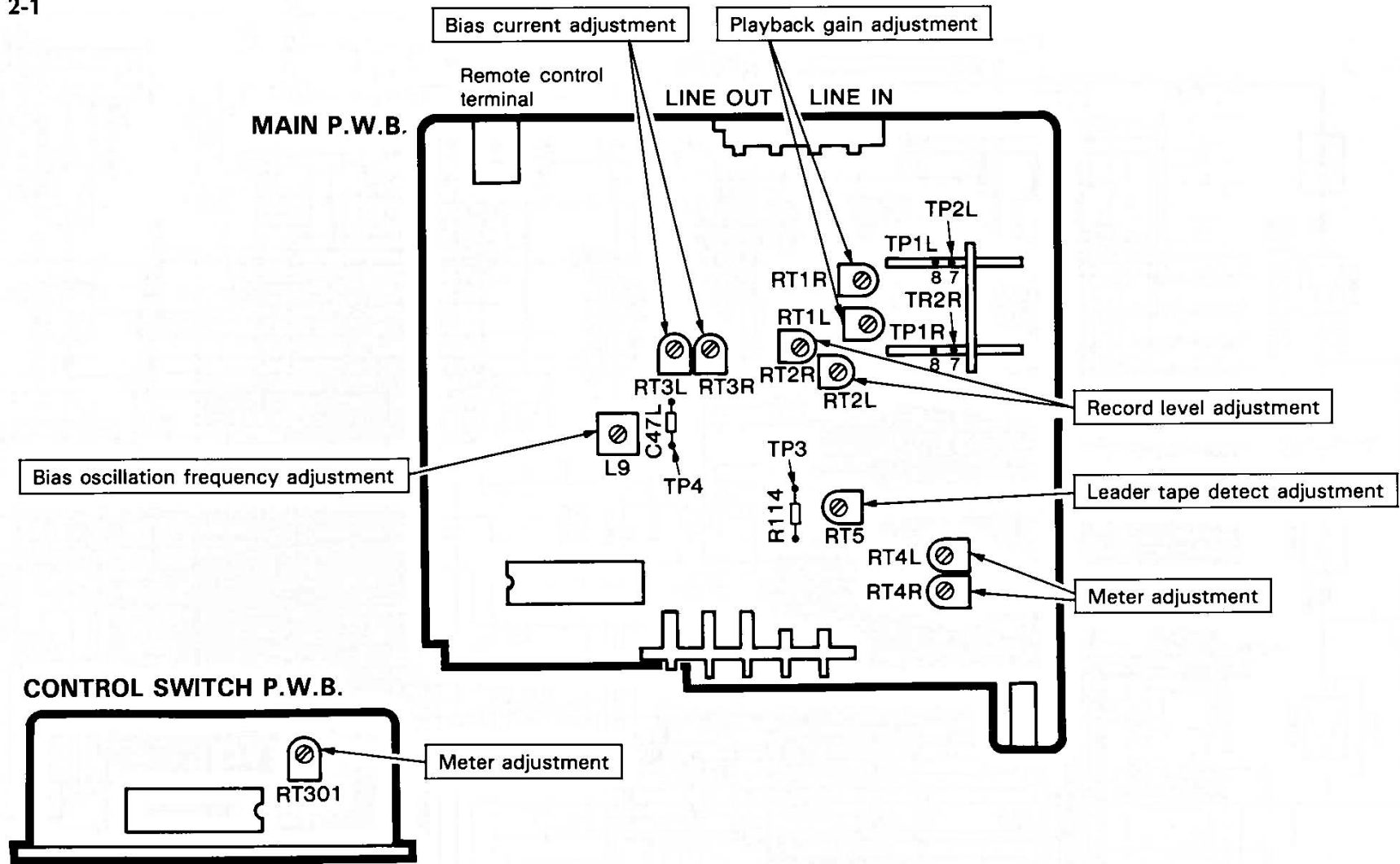

• Tools, Test Tape, Check Tape

1. Head Attachment Tools
2. 400 Hz, Dolby Standard Tape
3. 10 kHz, Azimuth Adjustment Tape
4. 3,000 Hz, Tape Speed Adjustment Tape
5. Mirror Tape (Tape Run Check)
6. Normal "Standard" Tape (TDK AD Tape)
7. Chrome "Standard" Tape (TDK SA Tape)
8. Metal Tape (TDK MA Tape)

• Measuring Instruments

1. Standard wave Oscillator
2. Electronic Voltmeter
3. Attenuator
4. Wave Frequency Counter

• Knob Position

Adjust the position of the knobs and switches to the positions on the table below if no other indication is given.

Recording level adjustment (RV1)	Maxm.
Output adjustment (RV2)	Maxm.
Dolby NR switch (S4)	OFF
Tape changeover switch (S1 ~ 3)	See Note 1.
Monitor switch (S6)	TAPE
Bias fine adjustment (RV3)	CENTER

Note 1: Switch the changeover switch as follows for tape where it is used.

Tape used	Changeover switch (S1 ~ 3)
No tape used	NOR-I
Test tape	NOR-I
Normal "standard" tape	NOR-I
Chrome "standard" tape	CrO ₂ -II
METAL tape	METAL-IV

Remove the cassette lid and then clean the heads, pressure roller and capstan using alcohol; then perform adjustment according to the following procedure.

2-1. Tape Speed Adjustment

Input	Adjustment value	Adjustment point
Tape speed adjustment tape	3,000 ⁺³⁰ Hz ₋₁₀	Semi-variable volume inside motor

• Adjustment Procedure

Connect the wave frequency counter to the LINE OUT terminal and playback the test tape after heat running for 20 minutes, Set to the intermediate position of the tape.

2-2. Azimuth Adjustment of Recording/Playback Head

Input	Adjustment value	Adjustment point
Azimuth adjustment tape	Output Maximum	Head azimuth adjustment screw

• Adjustment Procedure

- 1) Connect the electronic voltmeter to the LINE OUT terminal, playback the test tape and proceed to adjustment.
Adjust the section ⑥ at forward, and the screw at the section ⑤ at reverse. (See Fig. 2-2)
When the maximum value differs between both channels, adjust to the maximum value of L channel. At this time make sure that the difference of the maximum value between both channels is within 2 dB. When the difference is excessive, proceed to readjustment.
- 2) If the azimuth has been off considerably, readjust by means of the head attachment tools.

Fig. 2-2

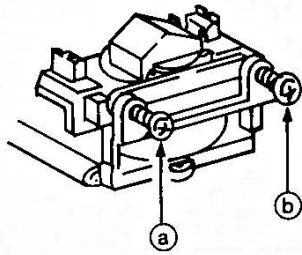

2-3. Adjustment of Playback Gain and Meter

1) Adjustment of Playback Gain

Input	Adjustment value	Adjustment point
400 Hz Dolby standard tape	500 mV ± 0.2 dB	RT1L, R

• Adjustment Procedure

Connect the electronic voltmeter to the LINE OUT terminal, playback the Dolby standard tape, and perform adjustment so that reading on the electronic voltmeter is the adjustment value.

2) Adjustment of Meter

Input	Adjustment value	Adjustment point
400 Hz Dolby standard tape	500 mV - 0.5 dB	RT4L, R
	500 mV - 37 dB	RT301

• Adjustment Procedure

1. Connect the low frequency oscillator to the recording terminal through the attenuator, and set the mode to recording.

2-6. Adjustment of Bias Current and Recording/Playback Output Level

Set RT3L, R to the middle positions and perform playback checks and adjustments for the tapes and recording levels indicated in the following table.

Procedure	Tape	Tape select switch	Recording level			Playback level		Adjustment procedure (next page)
			Frequency (Hz)	Level	Adjustment	Level	Adjustment	
1	Normal "standard" tape	NOR	1.2k/12k	500 mV - 23 dB	ATT	within +2 ± 0.5 dB	RT3L, R	1)
2	Normal "standard" tape	NOR	1.2k	500 mV - 10 dB	ATT	within +1 ± 0.5 dB	RT2L, R	2)
3	Normal "standard" tape	NOR	1.2k/12k	500 mV - 23 dB	ATT	within +2 ± 0.5 dB	Confirm	1)
4	Chrome "standard" tape	CrO ₂	1.2k/12k	500 mV - 23 dB	ATT	within ± 3 dB	Confirm	1)
5	METAL tape	METAL	1.2k/12k	500 mV - 23 dB	ATT	within ± 3 dB	Confirm	1)

2. Set the monitor switch to SOURCE, apply a signal of 400 Hz, and adjust the attenuator so that the output voltage of the LINE OUT terminal is 500 mV - 0.5 dB.
3. Adjust the RT4L, R at this time so the point of 0 dB on the meter changes from OFF to ON. (At this time, adjust RT301 at the center.)
4. Then, adjust the attenuator so that the output voltage of the LINE OUT terminal is 500 mV - 37 dB for both L, R ch.
5. Adjust the RT301 at this time so that the point of 40 dB of the meter changes from ON to OFF for both L, R ch.

2-4. Adjustment of Bias Oscillation Frequency

Set the changeover switch to the metal position. Then, set the forward and reverse sides to a recording status, and adjust L9 so that the lower side of the oscillation frequency of TP4 is 85 kHz ± 0.5 kHz. At this time, confirm one side is 85 kHz ± 5 kHz. If off positioned, drop the lower side so that both are 85 kHz ± 5 kHz by adjusting L9.

Fig. 2-3

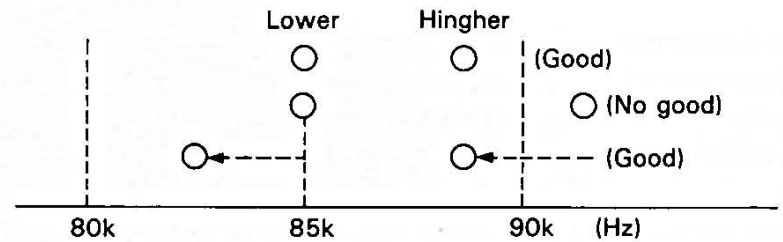

2-5. Coarse Adjustment of Recording level

Input	Adjustment value	Adjustment point
1.2 kHz	500 mV - 10 dB	RT2L, R

• Adjustment Procedure

Connect the low frequency oscillator to the LINE IN terminal, apply a signal of 1.2 kHz, and set the mode to recording. Then, set the MONITOR switch to SOURCE, and adjust the output of the low frequency oscillator so that the voltage of the LINE OUT terminal is 500 mV - 10 dB. Further, change the MONITOR switch to TAPE, and adjust RT2L, R so that the voltage at the LINE OUT terminal is 500 mV - 10 dB.

• Adjustment Procedure

1) Fine Adjustment of Bias Current

1. Connect the low frequency oscillator to the LINE IN terminal through the attenuator. Connect the electronic voltmeter to the LINE OUT terminal. Apply a signal of 1.2 kHz from the LINE IN terminal, and set the mode to recording. Then set the MONITOR switch to SOURCE, adjust the output of the low frequency oscillator so that the voltage at the LINE OUT terminal is 500 mV – 10 dB and then, by adjusting the attenuator, adjust it to 500 mV – 23 dB.
 2. Change the MONITOR switch to TAPE. Then change the frequency of the low frequency oscillator to 1.2 kHz and 12 kHz alternately, and adjust RT3L, R so that the difference in output between the two frequencies is within $+2 \pm 0.5$ dB. In this case, make adjustment so that the output at 12 kHz is sure to be greater than that at 1.2 kHz.
- * Just a check is carried out for chrome and metal tapes. If the specification of ± 3 dB is not satisfied, carry out readjustment with a normal tape.

2) Adjustment of Recording Level

1. Connect the low frequency oscillator to the LINE IN terminal, apply a signal of 1.2 kHz, and set the mode to recording. Then set the MONITOR switch to SOURCE, and adjust the output of the low frequency oscillator so that the voltage at the LINE OUT terminal is 500 mV – 10 dB.
2. Change the MONITOR switch to TAPE, and adjust RT2L, R so that the voltage at the LINE OUT terminal is 500 mV – 9 dB.

2-7. Dolby NR Operation Check

• Dolby B-Type

- 1) Record on a metal tape at a Dolby level of 5 kHz, – 40 dB. Continue recording with “Dolby OFF” and “Dolby B”.
- 2) Playback the “Dolby OFF” portion and confirm that the output difference between “Dolby OFF” and “Dolby B” is within 10 dB.

• Dolby C-Type

- 1) Record on a metal tape at a Dolby level of 1 kHz, – 40 dB. Continue recording with “Dolby OFF” and “Dolby C”.
- 2) Playback the “Dolby OFF” portion and confirm that the output difference between “Dolby OFF” and “Dolby C” is within 16 dB.

2-8. Operation Check of Fine Adjustment of Bias

Connect the low frequency oscillator to the LINE IN terminal, apply a signal of 12 kHz, and adjust the voltage at the LINE OUT terminal to 500 mV – 23 dB. Record a normal tape at that level and then play it back. Suppose the level is 0 dB when the fine adjustment knob for bias current is set at middle. Confirm the level is beyond + 2 dB when the knob is turned counterclockwise all the way, and beyond – 2 dB when clockwise all the way.

2-9. Adjustment of Leader Tape Detector Circuit

Position RT5 at 12 o'clock in terms of the clock pointers. Play back reversely the magnetic portion of Normal “standard” tape, and adjust RT5 so that the DC voltmeter connected between TP3 and chassis ground indicates 1.5 ~ 2.0V. Then confirm with the same tape that the head reverses in the reverse mode.

2-10. Inspection and Adjustment of Cassette Mechanism

NO.	Inspection item	Measurement procedure	Standard value
1	Pinch roller compression (for L, R)	Measure by tension gauge (Fig. 2-4)	450g min.
	Tape drive force	Measure by torque cassette (Fig. 2-4)	90g min.
2	Reel motor swing torque	Measure by tension gauge (Fig. 2-5)	3.0–8.0 g-cm
3	FF/REW torque	Measure by torque cassette	90–170 g-cm
4	Wind torque	Measure by torque cassette	30–70 g-cm
		Measure by torque cassette	3.5–7.0 g-cm
5	AT PLAY	Measure by tension gauge	6.0–9.5 g-cm
	AT FF/REW	Measure by tension gauge	6.0–9.5 g-cm
6	Erase head lock force allowance (for both L, R)	Measure by tension gauge (Fig. 2-6)	80g min.

Fig. 2-4

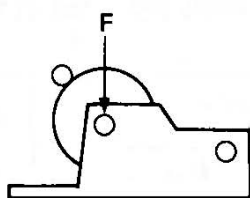

Fig. 2-5

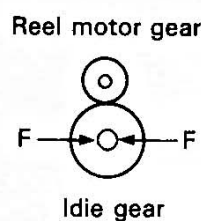
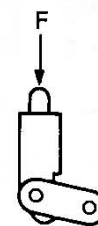

Fig. 2-6



3. DISASSEMBLY

Fig. 3-1

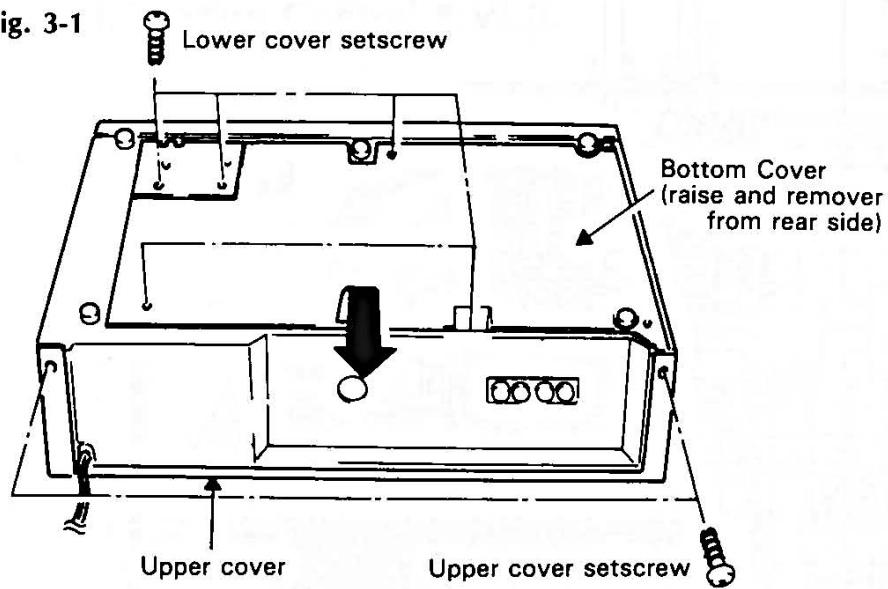

Fig. 3-5

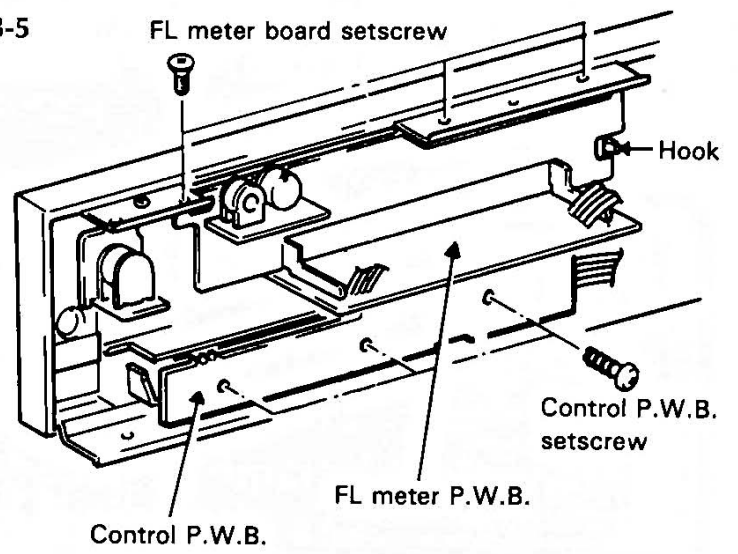

Fig. 3-2

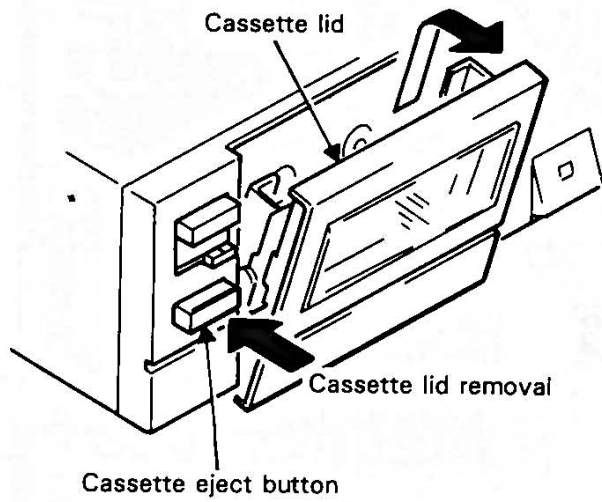

Fig. 3-6

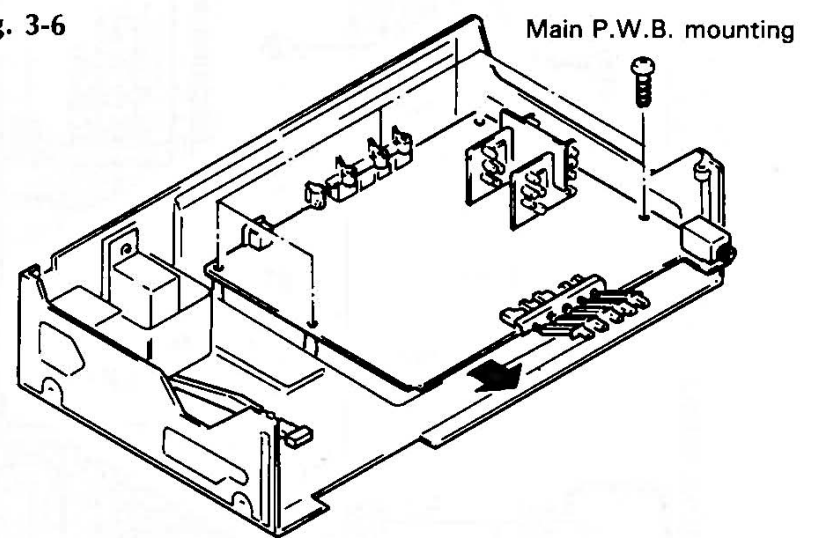

Fig. 3-3

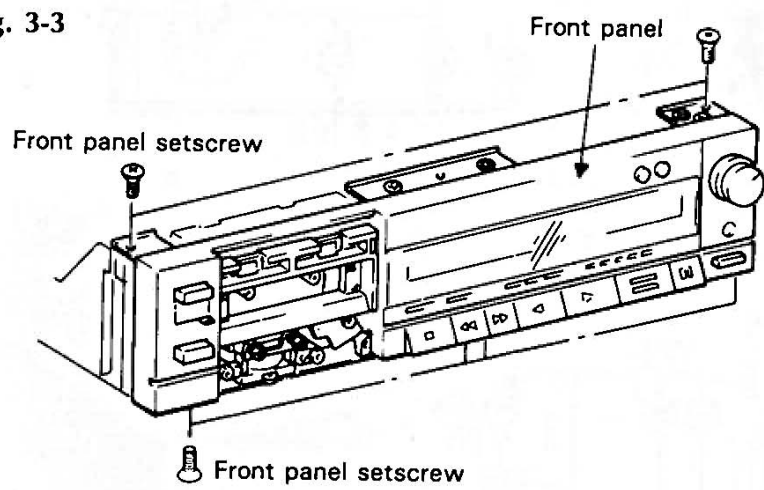
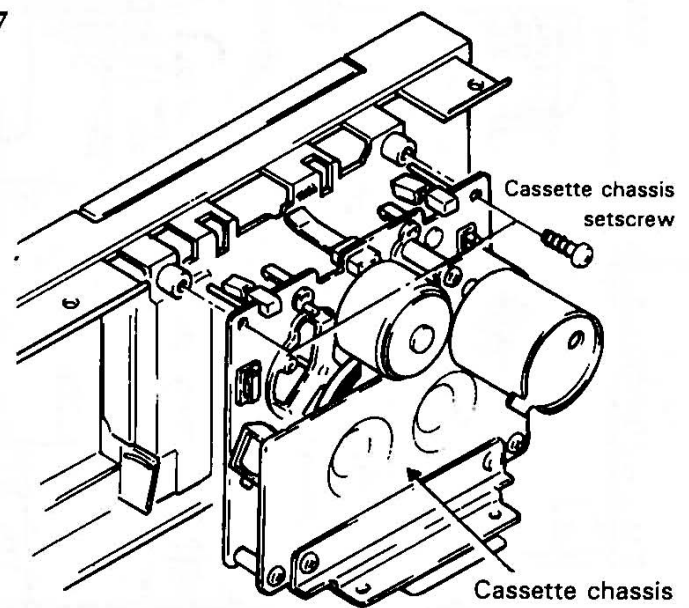

Fig. 3-7



Note:

Before extracting the front panel, detach the leads of the cassette chassis from the hooks (4 positions) on the cabinet. (Fig. 3-4)

Note:

The leads for the recording/playback head and those for the erasing head are engaged with hooks on the mold chassis under the mechanism and front panel, respectively. Before taking out the cassette chassis from the chassis, detach the leads for the heads.

Fig. 3-4

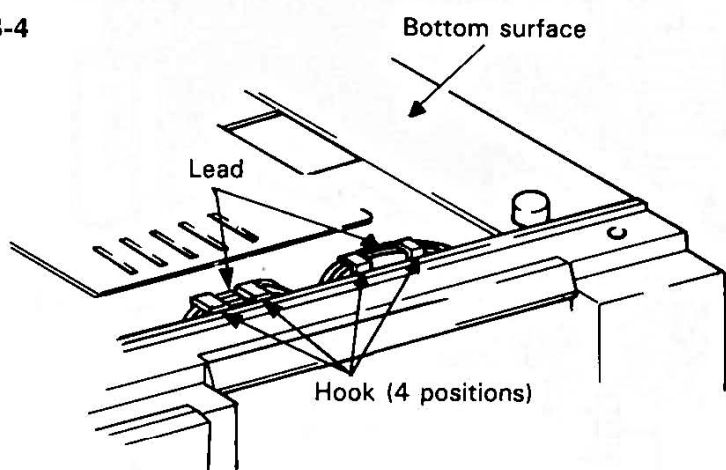

4. WIRING DIAGRAM

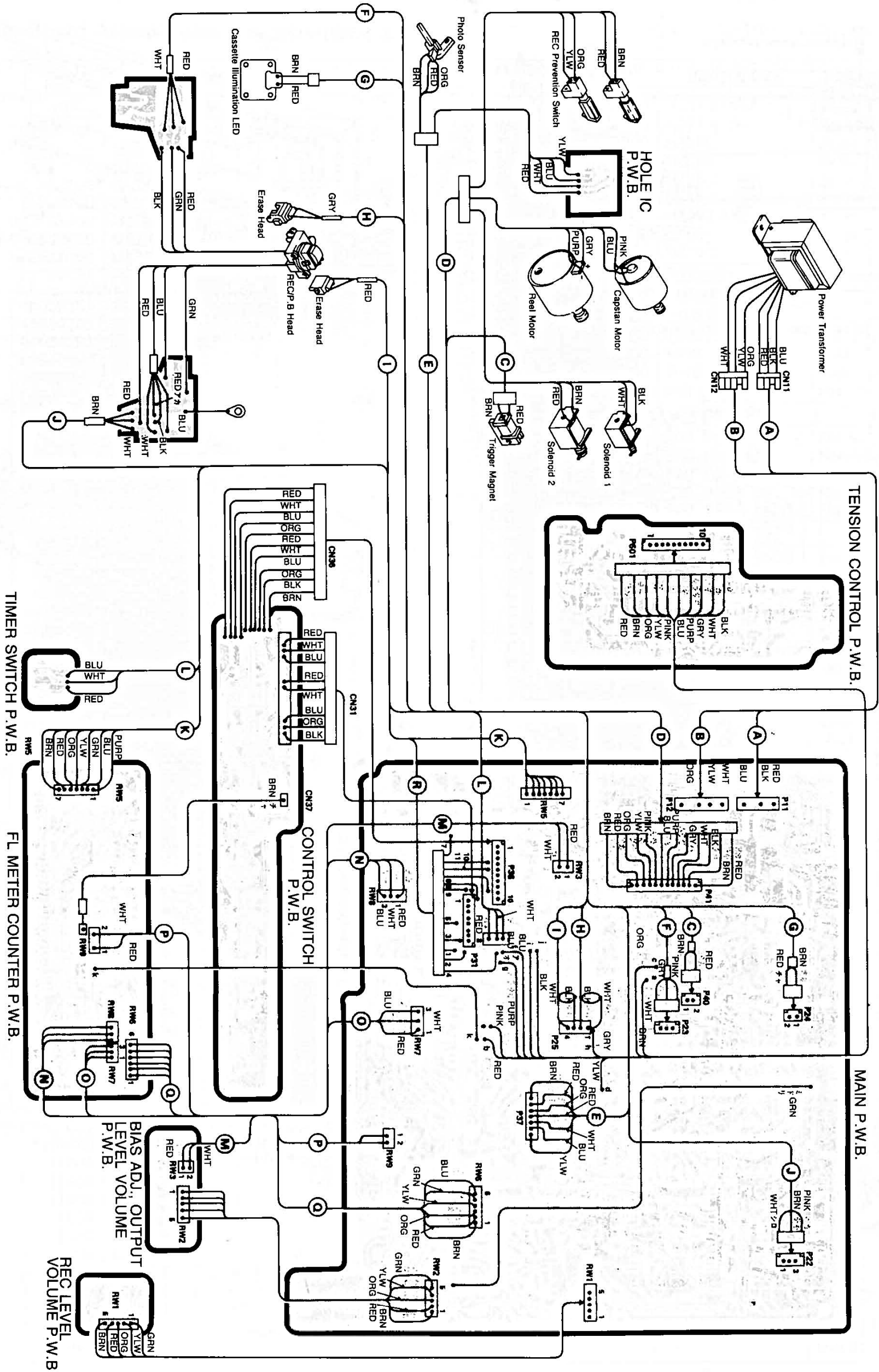

5. PRINTED WIRING BOARD (Conductor Side)

5-1. Main P.W.B.

[:+B, :-B, :Earth, :Other]

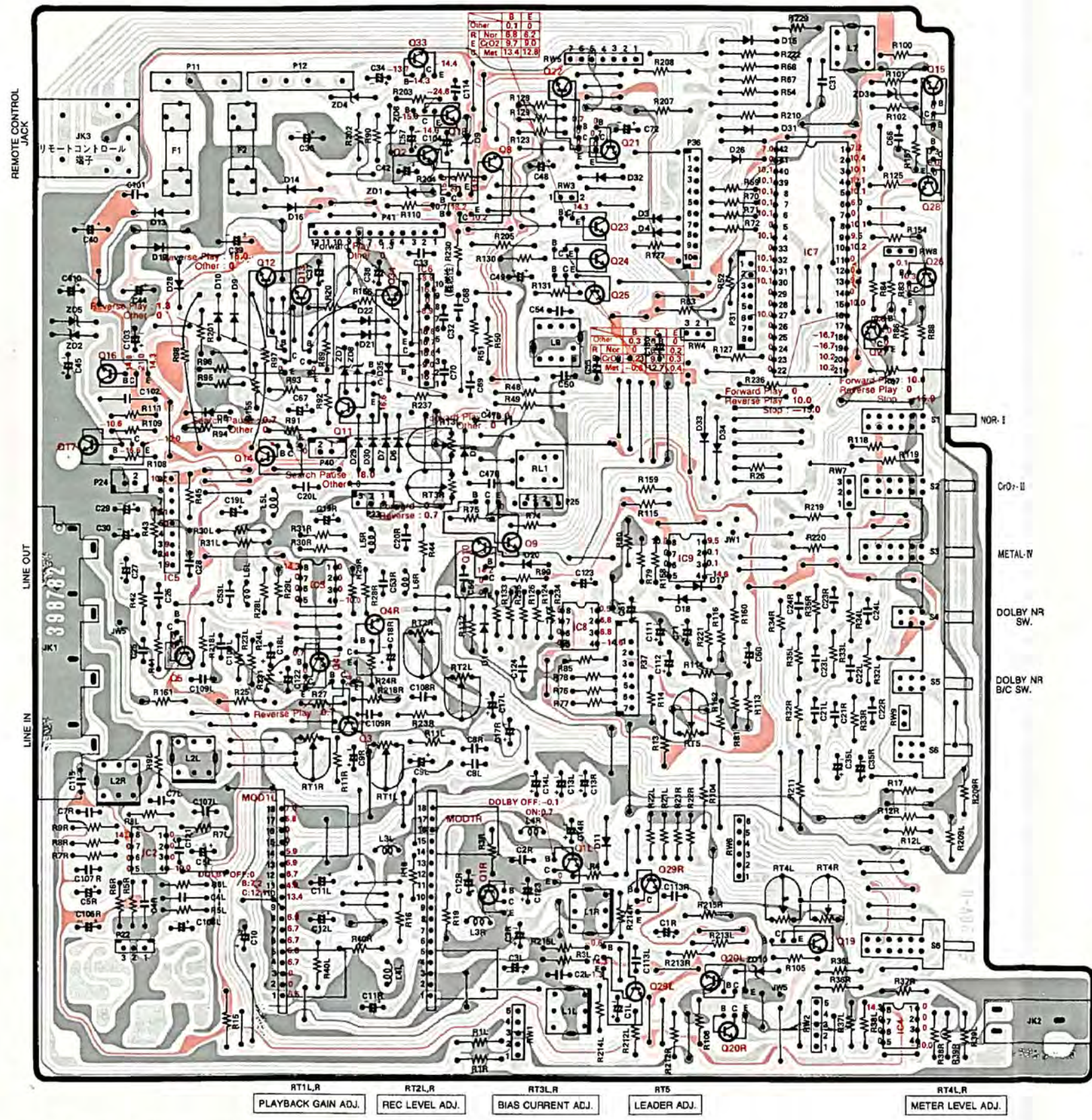

5-2. Control Switch P.W.B.

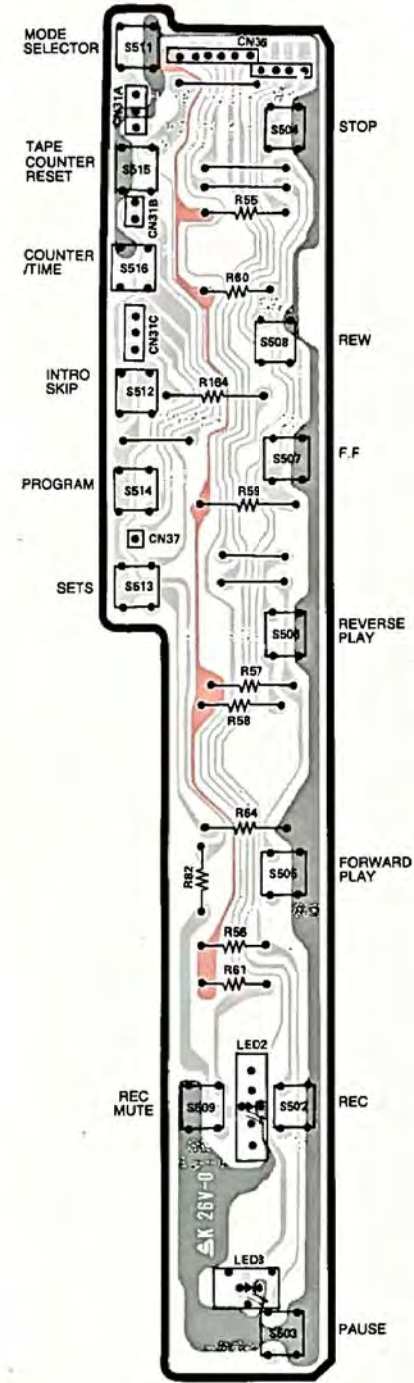

5-3. FL Meter Counter P.W.B.

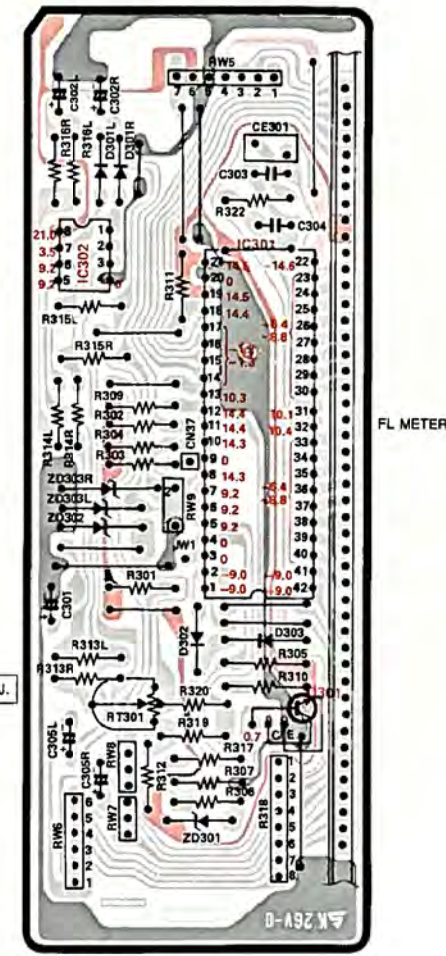

TM3506	1
M5218P NJM4562DD	2
8765	3
1234	4
BA335	5
BA6107	6
μPD53C-311 M58845-400P	7
42	8
1	9
21	10
BU4011B BU4066B	11
14	12
8	13
1	14
2SD1266P	15
BC	16
2SC1740LN 2SC1740LNT	17
2SD1111 2SD1468	18
ECB	19
2SA933 2SD468C	20
ECB	21
2SB605LA 2SD571LA	22
ECB	23
1S2473 HZ-3C-3 HZ-6B HZ-7A HZ-7C-3 HZ-9B-3 HZ-9C-1 HZ-11B-2 HZ-12C-3 HZ-15-2	24
K A	25
K A	26
K A	27
ERB12-01R	28
K A	29
K A	30

*Axial lead cylindrical ceramic capacitor

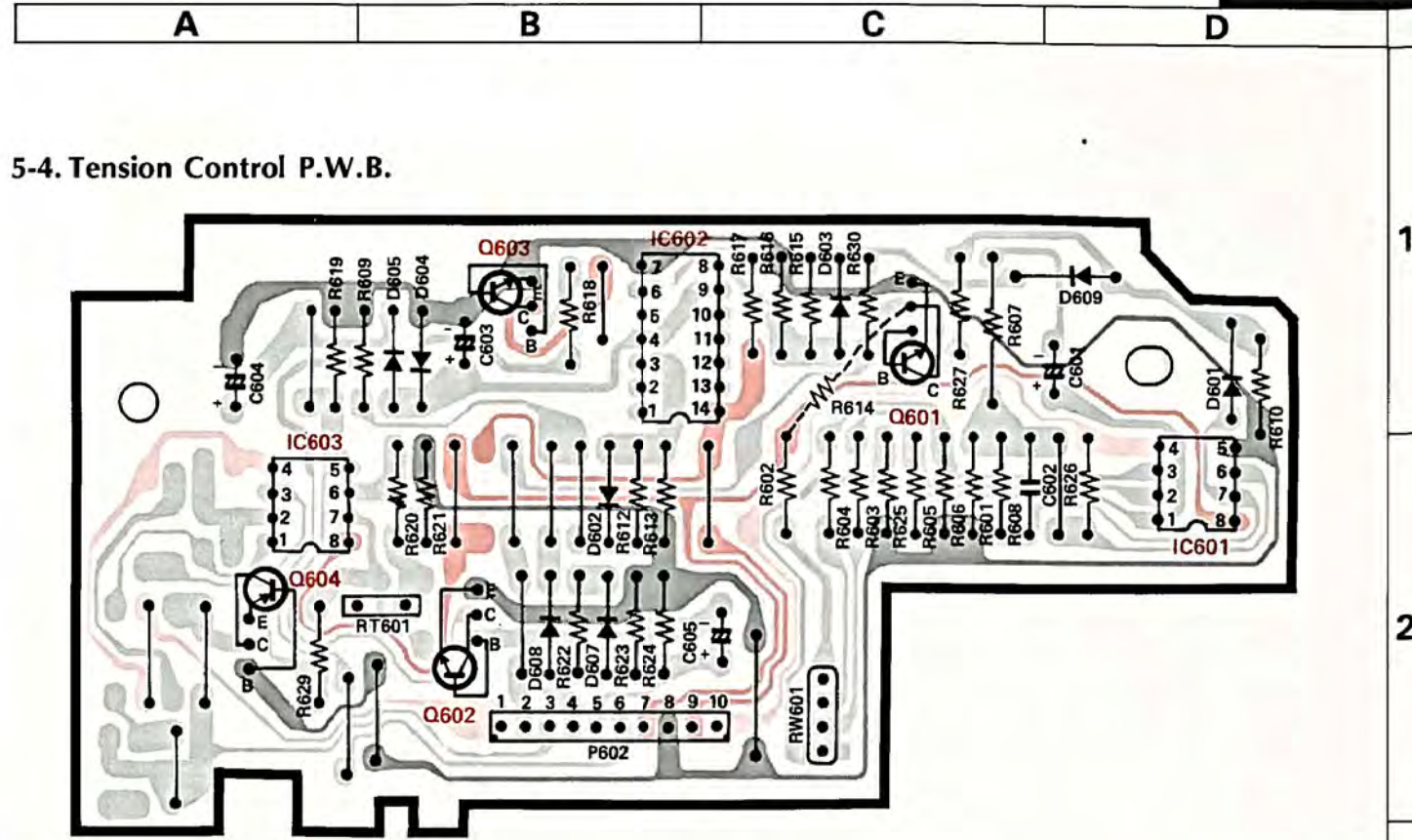

6. ELECTRICAL PARTS LIST

6-1. Main Board Assembly (Stock No. 58190100)

SYMBOL No.	STOCK No.	PART NAME	DESCRIPTION
ICs			
IC2	58185500	NJM4562	
IC3	46580100	M5218P	
IC4	46580100	M5218P	
IC5	07252300	BA335	
IC6	58185200	BA6107	
IC7	58185400	μPD553C-342	
IC8	46580100	M5218P	
IC9	46580100	M5218P	
TRANSISTORS			
Q1L,R	48058701	2SC1740LNS	
Q2	46546701	2SD880	
Q3	48058701	2SC1740LNS	
Q4L,R	48055901	2SD1468	
Q5	48058701	2SC1740LNS	
Q8	58183500	2SD468	
Q9	48058701	2SC1740LNS	
Q10	48058701	2SC1740LNS	
Q11	48058701	2SC1740LNS	
Q12	46134200	2SD1111	
Q13	46134200	2SD1111	
Q14	48058701	2SC1740LNS	
Q15	48058701	2SC1740LNS	
Q16	58183400	2SD1266	
Q17	58183600	2SB605LA	
Q18	58183600	2SB605LA	
Q19	48058701	2SC1740LNS	
Q20L,R	48055901	2SD1468	
Q21	48058701	2SC1740LNS	
Q22	48058701	2SC1740LNS	
Q23	58183500	2SD468	
Q24	48058701	2SC1740LNS	
Q25	48058701	2SC1740LNS	
Q26	48058701	2SC1740LNS	
Q27	48058701	2SC1740LNS	
Q28	48058701	2SC1740LNS	
Q29L,R	48058701	2SC1740LNS	
Q33	48058701	2SC1740LNS	
Q34	48058701	2SC1740LNS	
DIODES			
D1	03111600	1S2473	
D3	03111600	1S2473	
D4	03111600	1S2473	
D5	03111600	1S2473	
D6	03111600	1S2473	
D7	03111600	1S2473	
D8	03111600	1S2473	
D9	03111600	1S2473	
D10	03111600	1S2473	
D11	03111600	1S2473	
D12	58184600	ERB12-01R	
D13	58184600	ERB12-01R	
D14	58184600	ERB12-01R	
D15	03111600	1S2473	
D16	58184600	ERB12-01R	
D17	03111600	1S2473	
D18	03111600	1S2473	
D20	03111600	1S2473	
D21	03111600	1S2473	
D22	03111600	1S2473	
D26	03111600	1S2473	
D28	03111600	1S2473	
D29	03111600	1S2473	
D30	03111600	1S2473	
D31	03111600	1S2473	
D32	03111600	1S2473	
D33	03111600	1S2473	
D34	03111600	1S2473	

SYMBOL No.	STOCK No.	PART NAME	DESCRIPTION
ZD1	58184300	HZ11(B)-2	Zener
ZD2	58184300	HZ11(B)-2	Zener
ZD3	58183700	HZ7(A)	Zener
ZD4	58183800	HZ6(B)	Zener
ZD5	58184100	HZ15-2	Zener
ZD6	58184100	HZ15-2	Zener
ZD7	58183900	HZ99B-3	Zener
ZD8	58184500	HZ5B-1	Zener
ZD9	58184100	HZ15-2	Zener
ZD10	58184200	HZ7C-3	Zener
SEMI-VARIABLE RESISTORS			
RT1L,R	58181800	10kΩ (B)	Playback Gain Adj.
RT2L,R	58181800	10kΩ (B)	REC Level Adj.
RT3L,R	58182000	50kΩ (B)	BIAS Current Adj.
RT4L,R	58181900	20kΩ (B)	Meter Level Adj.
RT5	58181700	5kΩ (B)	Leader Adj.
RESISTORS			
ΔR15	58182200	10Ω 1/4W	Fusing
R97	46903000	56Ω 3W	Non-Inflammable
R98	46903000	56Ω 3W	Non-Inflammable
R156	00146800	22Ω 2W	Non-Inflammable
ΔR230	58182300	82Ω 1/4W	Fusing
CAPACITORS			
C1L,R	46550800	10μF 16V	Electrolytic
C3L,R	46550800	10μF 16V	Electrolytic
C4L,R	58180600	180pF 50V	Ceramic, cylindrical
C17L,R	46550800	10μF 16V	Electrolytic
C18L,R	48363800	0.1μF 50V	Electrolytic
C19L,R	46550800	10μF 16V	Electrolytic
C27	46550800	10μF 16V	Electrolytic
C30	58181000	0.15μF 50V	Electrolytic
C34	58180900	47μF 10V	Electrolytic
C35L,R	46550800	10μF 16V	Electrolytic
C36	48176100	220μF 25V	Electrolytic
C39	48176100	220μF 25V	Electrolytic
C40	48176100	220μF 25V	Electrolytic
C47L,R	58180500	150pF 50V	Ceramic, cylindrical
C50	58182400	820pF 100V	Film (Mylar)
C55	58180300	4700pF 50V	Ceramic, cylindrical
C60	58180900	47μF 10V	Electrolytic
C67	48364200	0.47μF 50V	Electrolytic
C71	58180900	47μF 50V	Electrolytic
C72	46550600	33μF 10V	Electrolytic
C101	58180400	0.01μF 50V	Ceramic, discal
C103	46551300	10μF 25V	Electrolytic
C106L,R	46551200	4.7μF 25V	Electrolytic
C108L,R	58180100	470pF 50V	Ceramic, discal
C109L,R	58180200	680pF 50V	Ceramic, discal
C112	48364000	0.22μF 50V	Electrolytic
C113L,R	58180100	470pF 50V	Ceramic, discal
C114	58180400	0.01μF 50V	Ceramic, discal
OTHER PARTS			
L1L,R	58183100	Dolby Filter	
L2L,R	58183100	Dolby Filter	
L3L,R	58182500	Trap Coil	19.8kHz
L4L,R	58182500	Trap Coil	19.8kHz
L5L,R	58182700	Trap Coil	85kHz
L6L,R	58185100	Choke Coil	3.3mH
L7	58182800	AM IF Trans	
L9	58182600	Bias OSC Coil	
MOD1L,R	58185300	TM3506 Module Ass'y	
RL1	58186500	Relay	
S1-5	58185900	Push Switch	TAPE SELECTOR, DOLBY NR

5-4. Tension Control P.W.B.

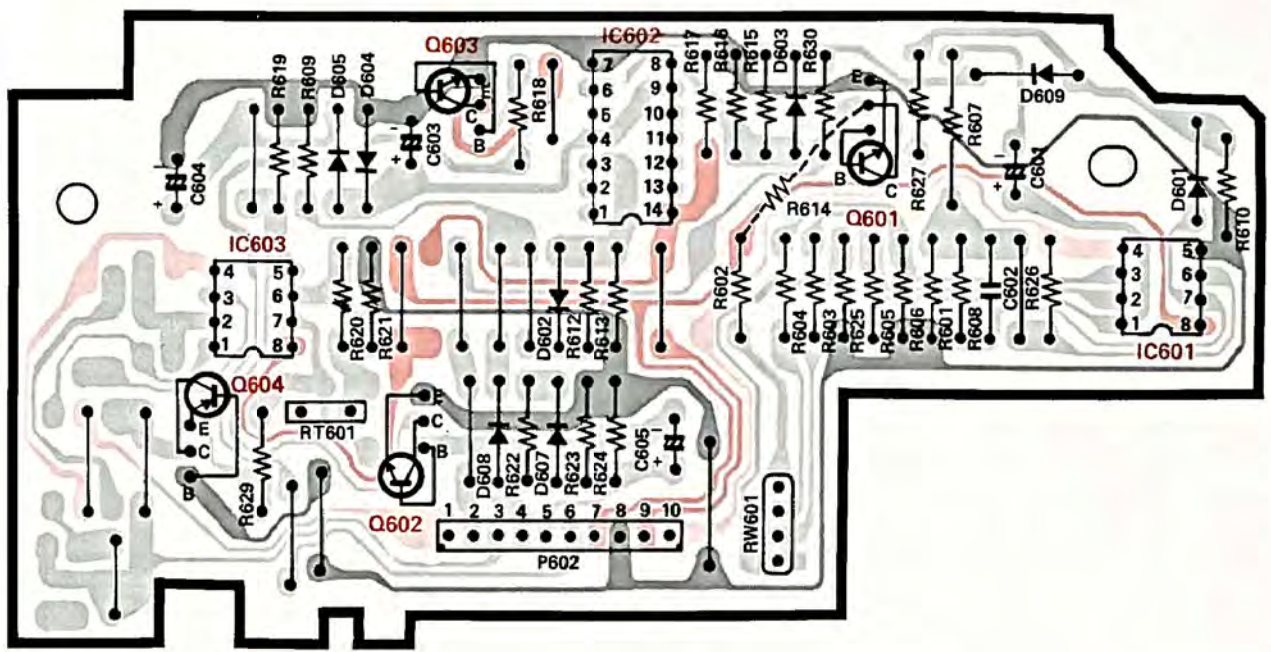

5-5. Hole IC P.W.B.

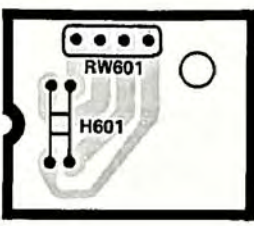

5-8. REC LEVEL Volume P.W.B.

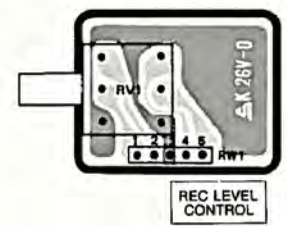

5-6. Timer Switch P.W.B.

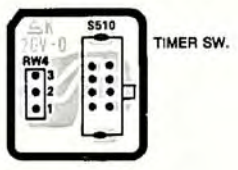

5-9. Power Supply P.W.B. (XX)

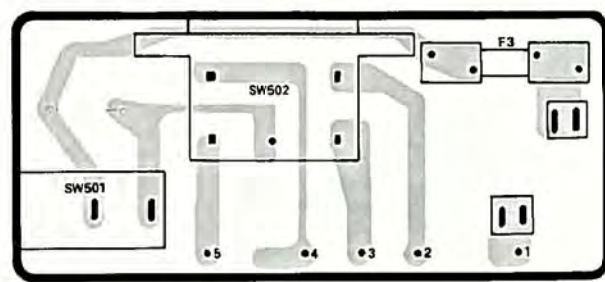

5-7. BIAS ADJUST, OUTPUT LEVEL Volume P.W.B.

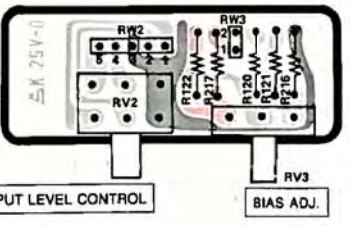

5-10. Power Supply P.W.B. (UL & CSA)

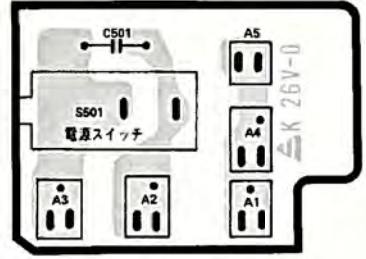

SYMBOL No.	STOCK No.	PART NAME	DESCRIPTION
S6	58186200	Push Switch	MONITOR
JK1	58186800	4P Pin Jack	
JK2	58186700	Headphone Jack	
JK3	58186600	8P DIN Jack	
F1	58187100	T1A Fuse	XX
	46201500	1A Fuse	UL & CSA
F2	58187200	T1.25A Fuse	XX
	46201700	1.6A Fuse	UL & CSA

6-2. Control Switch Board Assembly (Stock No. 58190300)

SYMBOL No.	STOCK No.	PART NAME	DESCRIPTION
LEDs			
LED2	58184700	GL-3PR2 (Red)	REC
LED3	58184900	SLH54YC(3) (Ylw)	PAUSE
SWITCHES			
S502	58186300	Tact Switch	REC
S503	58186300	Tact Switch	PAUSE
S504	58186300	Tact Switch	STOP
S505	58186300	Tact Switch	F. PLAY
S506	58186300	Tact Switch	R. PLAY
S507	58186300	Tact Switch	F.F.
S508	58186300	Tact Switch	REW
S509	58186300	Tact Switch	MUTE
S511	58186300	Tact Switch	REVERSE MODE
S512	58186300	Tact Switch	INTROSKIP
S513	58186300	Tact Switch	RMPS SET
S514	58186300	Tact Switch	RMPS PROGRAM
S515	58186300	Tact Switch	RESET
S516	58186300	Tact Switch	COUNTER/TIME

6-3. FL Meter Board Assembly (Stock No. 58190200)

SYMBOL No.	STOCK No.	PART NAME	DESCRIPTION
ICs			
IC301	58185400	M8845-400P	
IC302	46580100	M5218P	
TRANSISTORS			
Q301	48058701	2SC1740LNS	
DIODES			
D301L,R	03111600	1S2473	
D302	03111600	1S2473	
D303	03111600	1S2473	
ZD301	58184300	HZ11(B)-2	Zener
ZD302	58184000	HZ9C-1	Zener
ZD303L,R	58184400	HZ12C-03	Zener
RESISTORS			
RT301	58181600	200Ω (B)	Semi-Variable, meter adj.
R318	58182100	68kΩx7	Resistor Array
CAPACITORS			
C302L,R	46551200	4.7μF 25V	Electrolytic
C304	58180000	68pF 50V	Ceramic, discal
C305L,R	46551200	4.7μF 25V	Electrolytic
OTHER PARTS			
CE301	58182900	Ceramic Osillator	600kHz
FL301	58185700	FL Display Tube	

6-4. Tension Control Board Assembly (Stock No. 58190400)

SYMBOL No.	STOCK No.	PART NAME	DESCRIPTION
ICs			
IC601	46580100	M5218P	
IC602	48063800	BU4066B	
IC603	46580100	M5218P	
TRANSISTORS			
Q601	48058701	2SC1740LNS	
Q602	48058701	2SC1740LNS	
Q603	48058701	2SC1740LNS	
Q604	48058501	2SA933	
DIODES			
D601	03111600	1S2473	
D602	03111600	1S2473	
D603	03111600	1S2473	
D604	03111600	1S2473	
D605	03111600	1S2473	
D606	03111600	1S2473	
D607	03111600	1S2473	
D608	03111600	1S2473	
D609	03111600	1S2473	
SEMI-VARIABLE RESISTOR			
RT601	58181500	10kΩ (B)	

6-5. Hole IC Board

SYMBOL No.	STOCK No.	PART NAME	DESCRIPTION
H601	58185000	VHE-711H	Hole IC

6-6. TIMER Switch Board

SYMBOL No.	STOCK No.	PART NAME	DESCRIPTION
S510	58186000	Slide Switch	

6-7. BIAS ADJUST, OUTPUT LEVEL Volume Board

SYMBOL No.	STOCK No.	PART NAME	DESCRIPTION
RV2	58181400	10kΩ (B)	OUTPUT LEVEL
RV3	58181200	2kΩ (B)	BIAS ADJUST

6-8. REC LEVEL Volume Board

SYMBOL No.	STOCK No.	PART NAME	DESCRIPTION
RV1	58181300	50kΩ (A)	Variable Resistor

6-9. Power Supply Board (XX)

SYMBOL No.	STOCK No.	PART NAME	DESCRIPTION
ΔSW501	58186400	Power Switch	
ΔSW502	58186100	Voltage Selector Switch	
ΔF3	58187300	500mA Fuse	

6-10. Power Supply Board (UL & CSA)

SYMBOL No.	STOCK No.	PART NAME	DESCRIPTION
ΔSW501	58186400	Power Switch	
ΔC501	46425800	0.01μF 400V	Ceramic, discal

A B C D E F G H

7. EXPLODED VIEW OF CABINET AND PARTS LIST

Parts List

ITEM No.	STOCK No.	DESCRIPTION
1		Mold Chassis
2	58189800	Leg, felt
3	58181100	Bushing
4	58187900	Power Button Ass'y (XX)
	58188000	Power Button Ass'y (UL & CSA)
5	58188400	Monitor Button Ass'y
6	58188100	Eject Ass'y
7	58190800	Spring, headpin
8	58187800	Timer Knob
9	58188200	Tact Key
10	58190900	PS Washer
11	58188700	Push Knob Ass'y
12	58188900	Eject Lever
13	58189900	Front Panel Ass'y
14	58189100	Cassette Holder Ass'y
15	58188800	Spring, door
16	58189000	Air Damper Ass'y
17	58188300	Control Key Ass'y
18	58188600	RM Tact Key (MUTE)
19	58188500	RM Tact Key (REC)
20	58184800	SLF-301C LED
21	58187400	Cassette Door Ass'y
22	58189500	Bonnet
23	58189600	Head Cover
24	58187500	REC Knob Ass'y (L)
25	58187600	REC Knob Ass'y (R)
26	58187700	Knob
27		Bottom Cover
△28	58187000	Power Supply Cord
△29	58183301	Power Transformer (XX)
△	58183302	Power Transformer (UL & CSA)
30	13122300	M3x6 DT Bind Screw
31	58191100	M3x6 DT Flat Head Screw
32	48265000	M3x8 DT Flat Head Screw
33	00422000	M3x8 Bind Screw
34	00455400	M3x8 Bind Screw
35	46267800	M3x10 DT Bind Screw
36	00456100	M4x10 BT Bind Screw
37	00455500	M3x10 Bind Screw
38	00462800	M3x10 Flat Head Screw
39	00454700	M3x12 BT Bind Screw
40	00454800	M3x14 BT Bind Screw
41	58191000	M3x14 Bind Screw
42	00454500	M3x8 Bind Screw
43		M3x4 Bind Screw

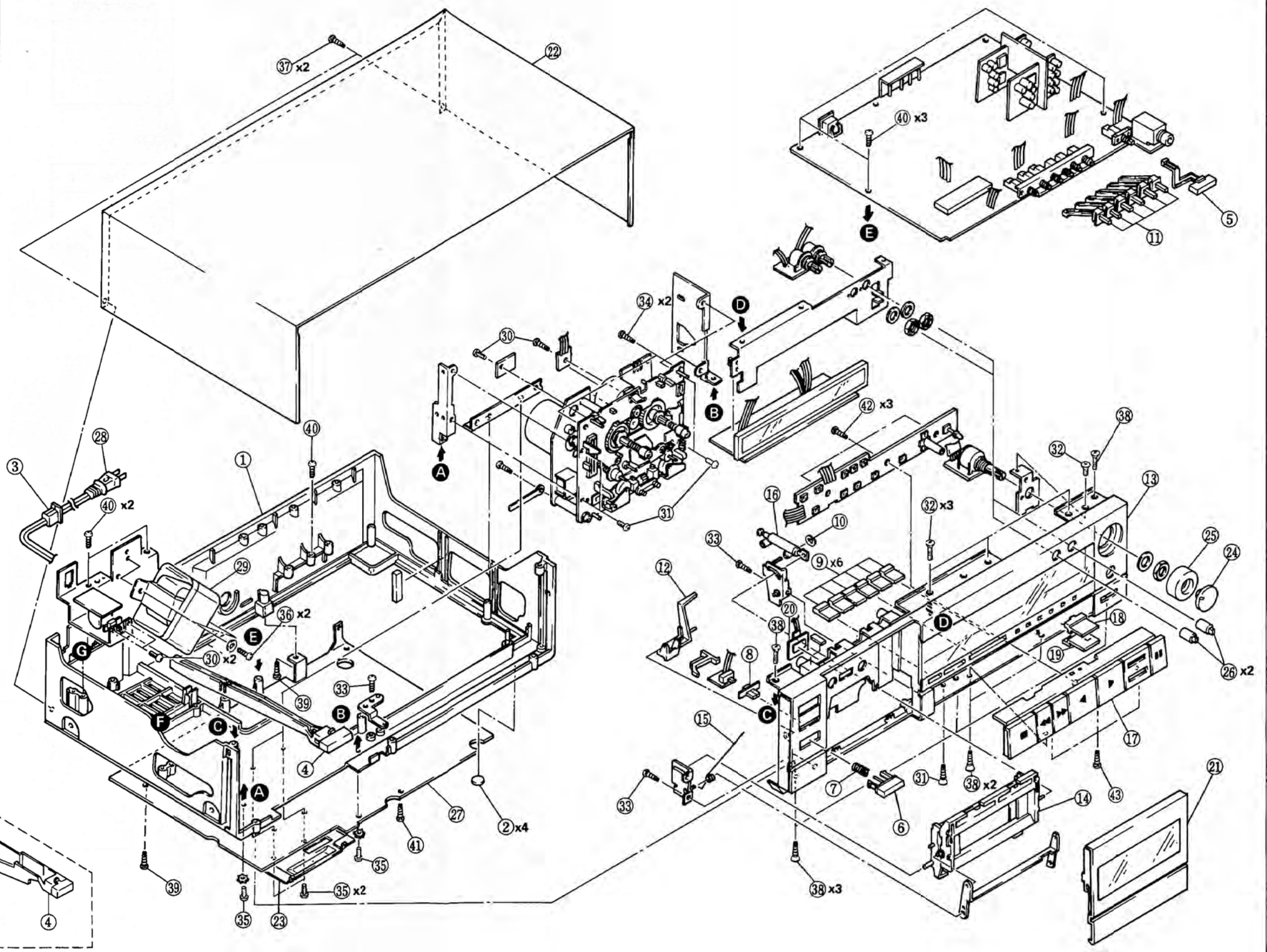

1
2
3
4
5

A

B

C

D

E

F

G

H

8. EXPLODED VIEW OF MECHANISM ASS'Y AND PARTS LIST

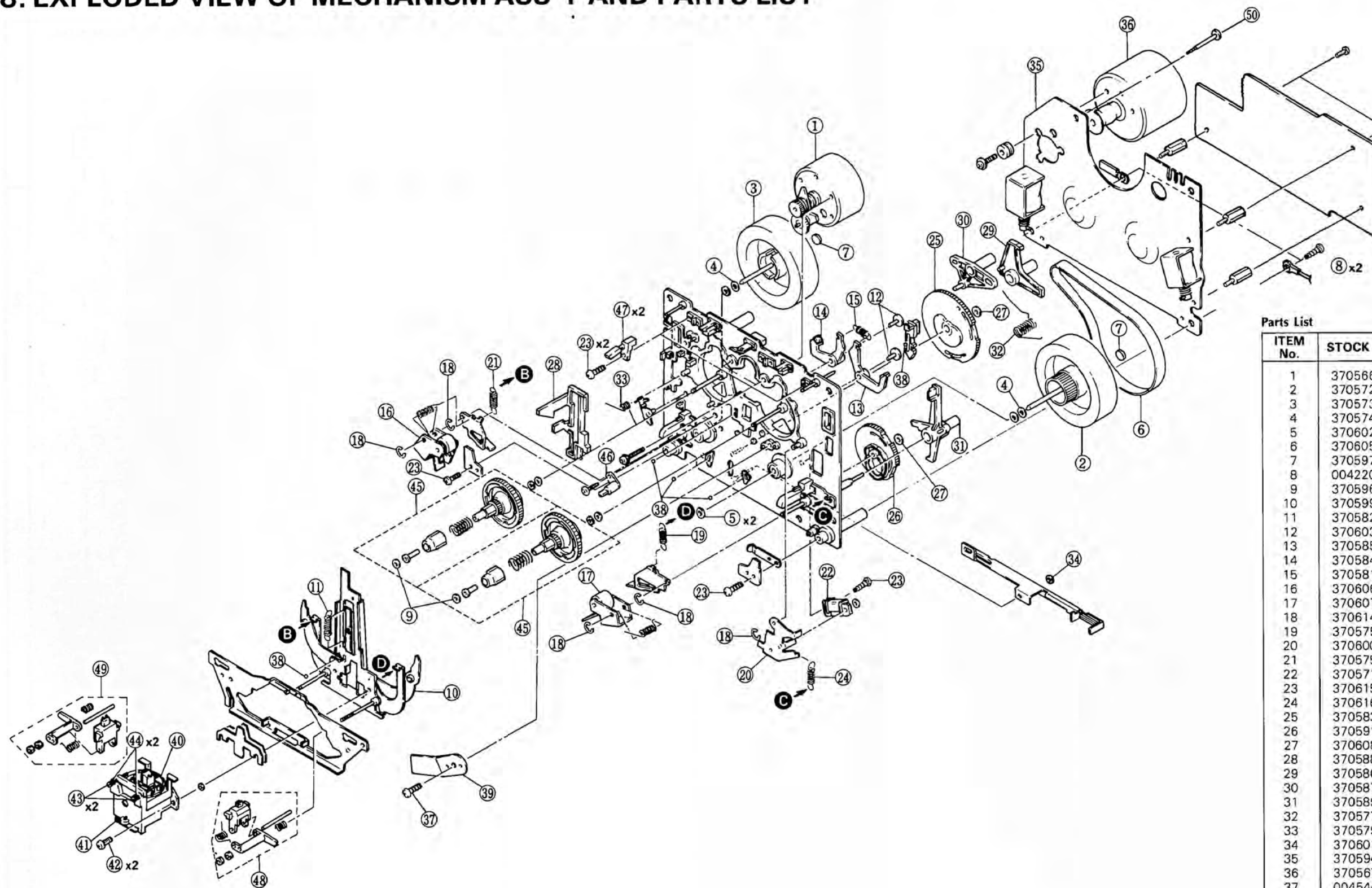

Parts List

ITEM No.	STOCK No.	DESCRIPTION
1	37056600	Reel Motor Gear Ass'y
2	37057200	Flywheel Ass'y (R)
3	37057300	Flywheel Ass'y (L)
4	37057400	Spring
5	37060200	PS Washer
6	37060500	Flywheel Belt
7	37059700	Flywheel Thrust Bearing
8	00422000	M3x8 Bind Screw
9	37059600	PS Washer
10	37059900	Headplate Ass'y
11	37058200	Spring, head plate
12	37060300	Pin
13	37058500	Brake (R)
14	37058400	Brake (L)
15	37058100	Spring
16	37060600	Pinch Roller Arm Ass'y (L)
17	37060700	Pinch Roller Arm Ass'y (R)
18	37061400	D=2 E-ring
19	37057500	Spring, pinch roller
20	37060000	Search Arm Ass'y
21	37057500	Spring, pinch roller
22	37057100	Trigger Magnet
23	37061500	M2x8 BT Bind Screw
24	37061600	Spring, search arm
25	37058300	Play PA Gear
26	37059100	Reverse Gear
27	37060800	PS Washer
28	37058800	Eject Slider
29	37058600	Play Trigger Arm
30	37058700	Solenoid Lever
31	37058900	Reverse Trigger Arm
32	37057700	Spring
33	37057900	Spring, eject
34	37060100	P Washer
35	37059400	Flywheel Plate Ass'y
36	37056700	DC Motor with Pulley
37	00454400	M3x6 BT Bind Screw
38	65400300	D=2 Steel Ball
39	37059800	Plate
40	37059500	REC/P.B Head Ass'y
41	37057800	Spring
42	00420500	M3x4 Bind Screw
43	37060400	Azimuth Screw
44	37057600	Azimuth Spring
45	37059000	Turntable Ass'y
46	36056500	LP101 Photo Sensor
47	37057000	Reaf Switch, Cassette detection
48	37056800	Erase Head Ass'y (R)
49	37056900	Erase Head Ass'y (L)
50	37061200	M3x30 BT Screw

9. SCHEMATIC DIAGRAM 9-1. Main Circuit

CAUTION
Use the electrolytic capacitors with explosion-proof valve when the diameter of them is more than 10 mm.

* : Axial lead cylindrical ceramic capacitor
△ is Safety Part.
Use only replacement parts recommended by the manufacturer.

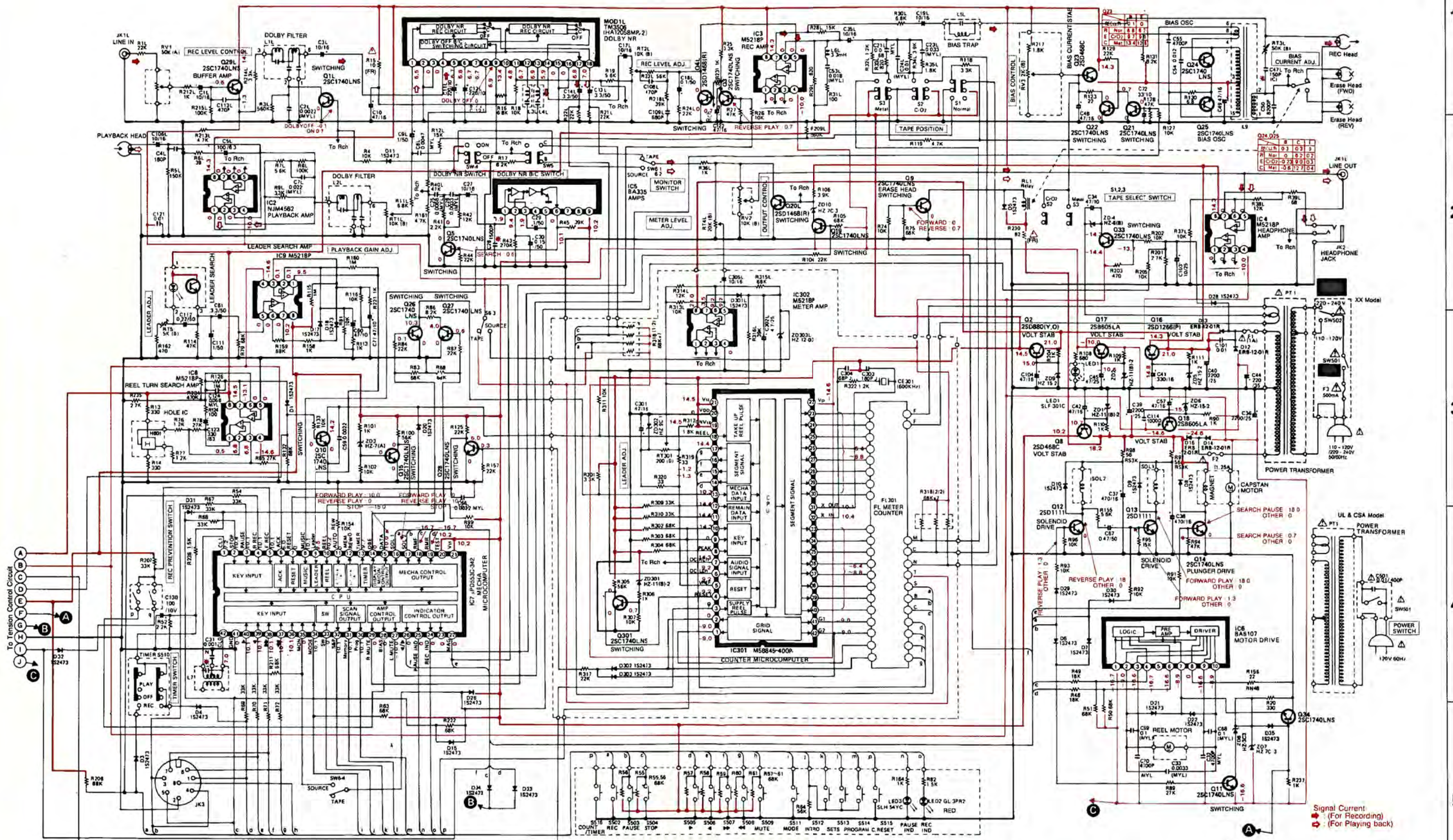

— + B Line, — - B Line

* Design and specifications subject to change without notice for improvement.
 * La présentation et les spécifications sont susceptibles d'être modifiées sans préavis par suites d'améliorations éventuelles.
 * Änderungen, die dem technischen Fortschritt dienen, bleiben vorbehalten.

A B C D

9-2. Tension Control Circuit

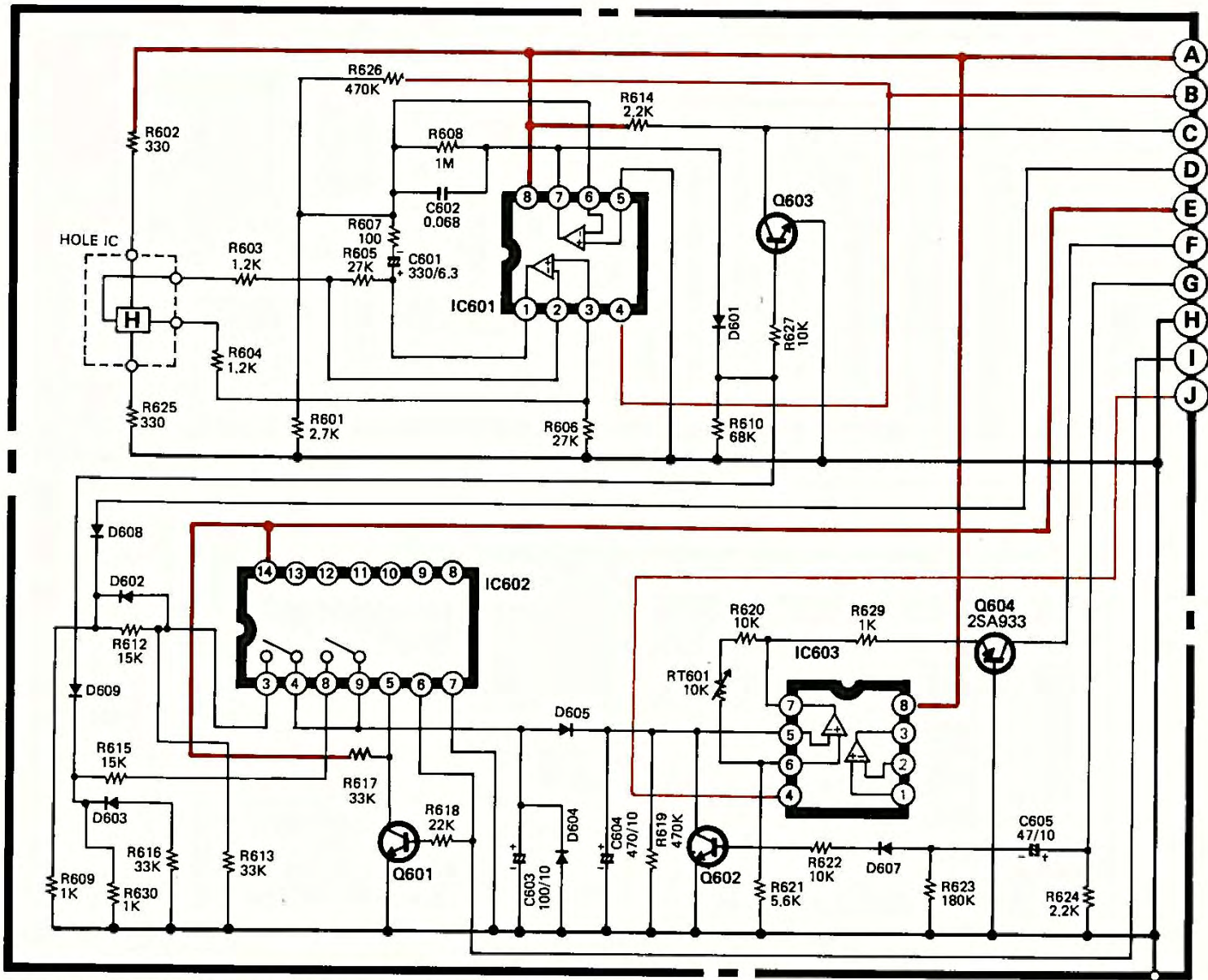

* Design and specifications subject to change without notice for improvement.
 * La présentation et les spécifications sont susceptibles d'être modifiées sans préavis par suites d'améliorations éventuelles.
 * Änderungen, die dem technischen Fortschritt dienen, bleiben vorbehalten.

NOTE

***RESISTORS**

All resistors are in ohms, 1/4W, ± 5% tolerance unless otherwise noted.

- K : Kohm
- M : Mohm
- no mark : Carbon Resistor
- RS : Oxied Metal Film Resistor
- RN : Metal Film Resistor
- FR : Fusing Resistor

***CAPACITORS**

All capacitors are in μF, 50WV unless otherwise noted.

- p : pF
- no mark : Ceramic Capacitor or Electrolytic Capacitor capacitance (μF)/voltage (V)
- MYL : Mylar (Film) Capacitor

1

2

3

4

5

10. PACKING LIST

ITEM No.	STOCK No.	DESCRIPTION
1	58190500	Carton Case
2	58190600	Styrofoam Packing (R)
3	58190700	Styrofoam Packing (L)
4	_____	Cover

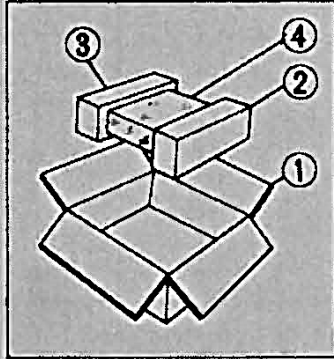

11. ACCESSORY LIST

STOCK No.	DESCRIPTION
46988900	Operating Instruction
58185800	Patch Cord
_____	Remote Control Unit

SANSUI ELECTRIC CO., LTD.:

SANSUI ELECTRONICS CORPORATION:

SANSUI ELECTRONICS (U.K.) LTD.:
SANSUI ELECTRONICS G.M.B.H.:14-1, Izumi 2-chome, Suginami-ku, Tokyo 168 Japan
PHONE: (03) 324-8891/TELEX: 232-2076 (International Division)
1250 Valley Brook Ave. Lyndhurst, N.J. 07071 U.S.A.
17150 South Margay Ave. Carson, California 90746 U.S.A.
3036 Koapaka Street, Honolulu, Hawaii 96819 U.S.A.Unit 10A, Lyon Industrial Estate, Rockware Avenue, Greenford, Middx UB6, 0AA, England
Pau Ehrich Strasse 8, 6074 Rödermark 2, West Germany

(SM1-275)

Printed in Japan (850410M) <Stock No. 36519600>