

SERVICE MANUAL

STEREO DOUBLE CASSETTE DECK

SANSUI D-99CW

(Silver & Black Model)

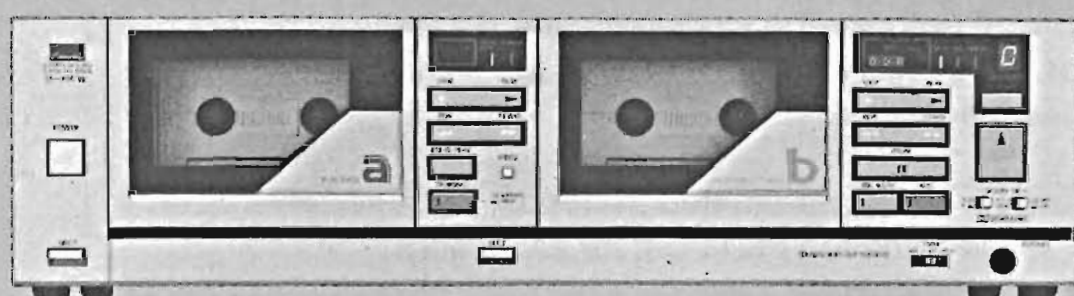

CAUTION

1. Parts identified by the  symbol on the schematic diagram and the parts list are critical for safety. Use only replacement parts that have critical characteristics recommended by the manufacturer.
2. Make leakage-current or resistance measurements to determine that exposed parts are acceptably insulated from the supply circuit before returning the appliance to the customer.

•SPECIFICATIONS

Track format	4-track/2-channel system
Tape speed	4.8 cm/sec, 9.5 cm/sec.
Heads	
Rec/play head	HIGH-Bs hard permalloy
Play head	HIGH-Bs hard permalloy
Erase head	Double-grap HIGH-Bs ferrite
Motor	
	Electronically controlled
	DC motor x 2
	Reels: DC Motor x 2
Wow/flutter	0.06% max (WRMS)
Fast forwarding (rewinding) time	
	Approx. 85 sec. (for C-60 tape)
Frequency response (-20 VU recording/playback)	
Normal tape (LH)	20 to 15,000 Hz
	(30 to 14,000 Hz ± 3 dB)
Chrome Tape	20 to 17,000 Hz
	(30 to 16,000 Hz ± 3 dB)
Metal Tape	20 to 17,000 Hz
	(30 to 16,000 Hz ± 3 dB)
Erase rate (metal tape)	70 dB min (1 kHz)
Recording bias frequency	
	85 kHz
Input sensitivity/impedance	
LINE IN (REC)	150 mV/47 kohms
Signal to noise ratio (Record/Playback)	
Metal Tape (without Dolby Noise Reduction) better than 54 dB
(With Dolby Noise Reduction Effect)	
DOLBY "B" NR	better than 10 dB
	(above 5 kHz)
DOLBY "C" NR	better than 20 dB
	(above 1 kHz)
Power requirements	
Power voltage	120/220/240V (50/60 Hz)
For U.S.A. and Canada 120V (60 Hz)
Power consumption	23W
Dimensions	
	430 mm (16-15/16") W
	118 mm (4-11/16") H
	223 mm (8-13/16") D
Weight	
	4.6 kg (10.1 lbs.) net
	5.5 kg (12.1 lbs.) packed

* Design and specifications subject to changes without notice for improvements.

* Noise reduction system manufactured under license from Dolby Laboratories Licensing Corporation.
"Dolby" and the double D symbol are trade marks of Dolby Laboratories Licensing Corporation.

Sansui

SANSUI ELECTRIC CO., LTD.

CAUTION

1. The symbols, UL, CSA, SA, BS, UK, EU, AS and XX on the parts list and the schematic diagram mean followings respectively.

UL..... Manufactured for U.S.A market.
 (Underwriters Laboratories approved model.)
 CSA Manufactured for Canadian market.
 SA..... Manufactured for South African market.
 BS, UK Manufactured for United Kingdom market.
 EU Manufactured for European market.
 AS..... Manufactured for Australian market.
 XX..... Standard Version.
 NON MARK Common Parts.

2. Some printed circuit boards are not supplied as the assembled. To separate these in this service manual, the stock No's are not indicated at the ends of the board names. However, the individual parts on the circuit boards are provided by orders.

3. Since some of capacitors and resistors are omitted from parts lists in this service manual, refer to the Common Parts List for capacitors & resistors, which was issued on February 1983.

4. Abbreviations in this service manual are as follows.

•Abbreviations List

C.R.	: Carbon Resistor	E.B.L.	: Low Leak Bi-Polar Electrolytic Capacitor
S.R.	: Solid Resistor	Ta.C.	: Tantalum Capacitor
Ce.R.	: Cement Resistor	F.C.	: Film Capacitor
M.R.	: Metal Film Resistor	M.P.	: Metalized Paper Capacitor
F.R.	: Fusing Resistor	P.C.	: Polystyrene Capacitor
N.I.R.	: Non-Inflammable Resistor	G.C.	: Gimmic Capacitor
A.R.	: Array Resistor	A.C.	: Array Capacitor
C.C.	: Ceramic Capacitor	V.R.	: Variable Resistor
C.T.	: Ceramic Capacitor, Temperature Compensation	S.V.R.	: Semi Variable Resistor
E.C.	: Electrolytic Capacitor	SW.	: Switch
E.L.	: Low Leak Electrolytic Capacitor	Chip R.	: Chip Resistor
E.B.	: Bi-Polar Electrolytic Capacitor	Chip C.	: Chip Capacitor

1. BLOCK DIAGRAM

1-1. Control Section

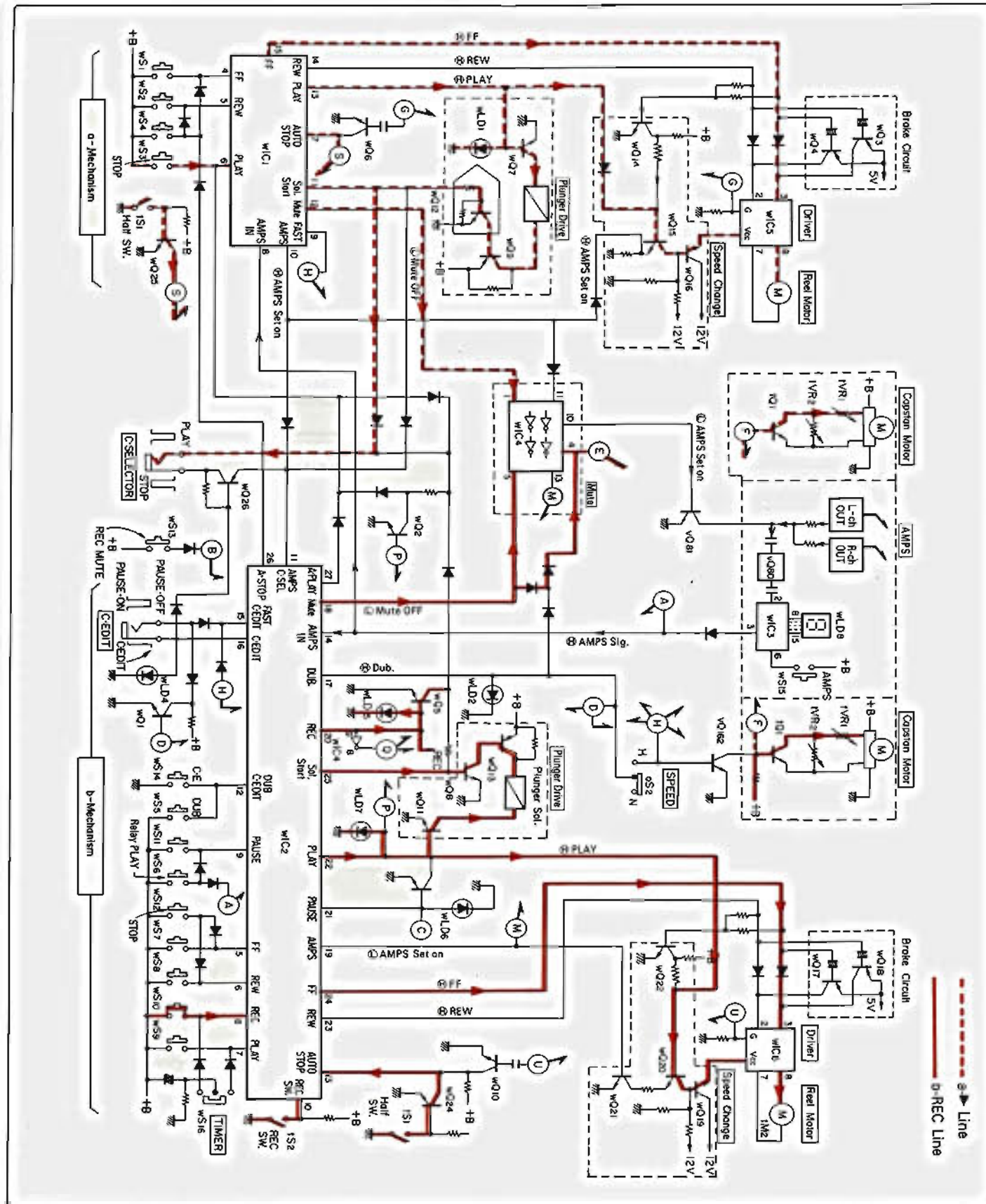

1-2. Amplifier Section

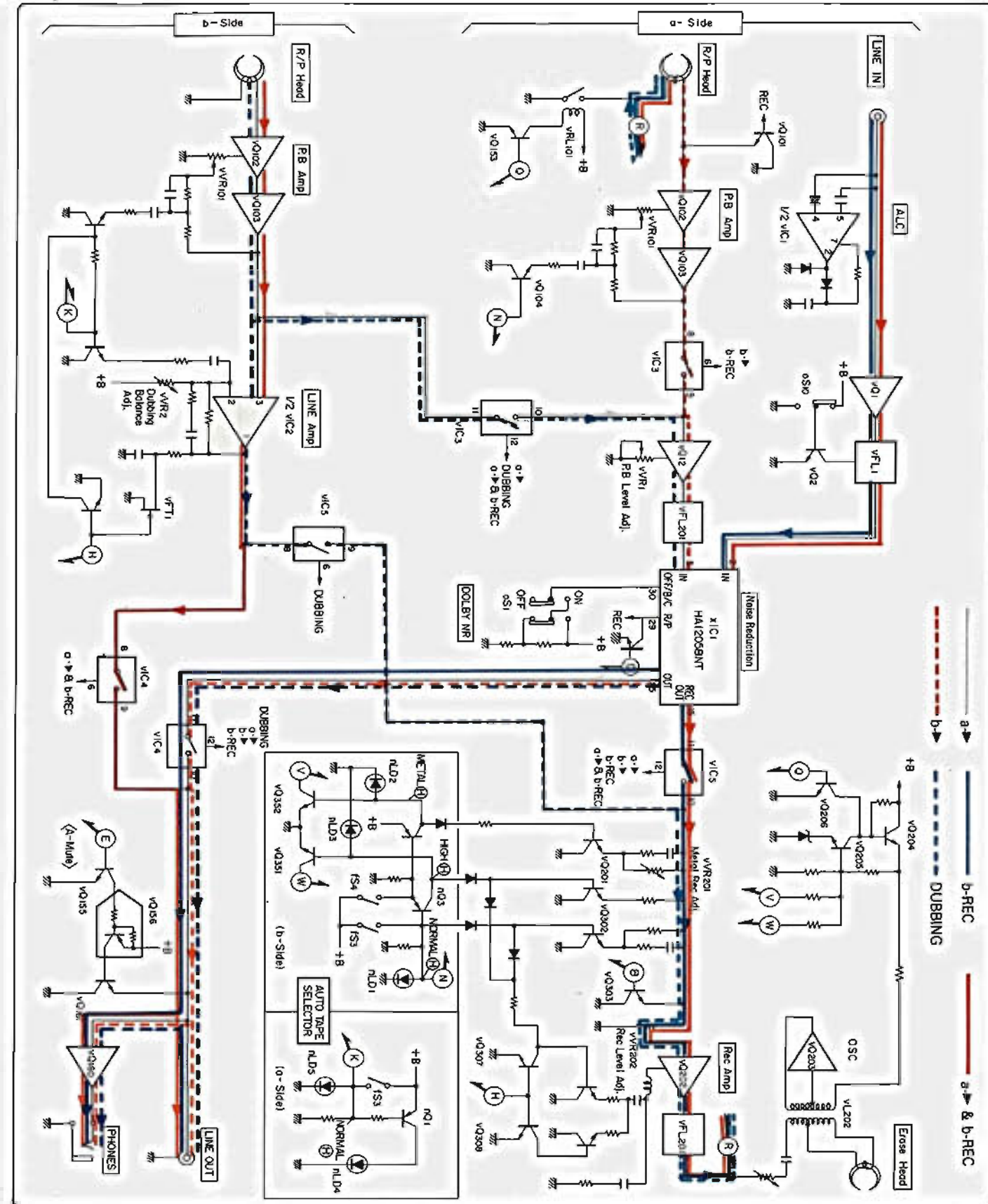

2. MODE CHANGE TABLE & TIMING CHART OF IC TC9310N-044 & TC9305P-004

- Note: 1. Mode change table shows operation when one input key is depressed on present mode.
- 2. Cue is in the state of PLAY mode under FF operation.
Review is in the state of PLAY mode under REW operation.

□ mark means continuing present mode.

•Mode Change Table of IC TC9310N-044 (WIC2)

Input Key	STOP (■)	FF (▶▶)	REW (◀◀)	PLAY (▶)	REC (●▶)	PAUSE (■)	PLAY (▶) a-Mecha.	COMP-SEL (STOP)	RELAY PLAY	STOP (■) a-Mecha.	AUTO STOP	DUB	COMP-E	PLAYER START	COMP-E
PRE MODE	—	—	—	—	—	—	—	—	—	—	—	—	—	—	—
STOP (■)	—	▶▶	◀◀	▶	●▶	■	▶▶	—	—	—	—	—	—	—	—
FF (▶▶)	—	▶▶	◀◀	▶	●▶	■	▶▶	—	—	—	—	—	—	—	—
REW (◀◀)	—	▶▶	◀◀	▶	●▶	■	▶▶	—	—	—	—	—	—	—	—
PLAY (▶)	—	▶▶	◀◀	▶	●▶	■	▶▶	—	—	—	—	—	—	—	—
REC (●▶)	—	▶▶	◀◀	▶	●▶	■	▶▶	—	—	—	—	—	—	—	—
PAUSE (■)	—	▶▶	◀◀	▶	●▶	■	▶▶	—	—	—	—	—	—	—	—
PLAY (▶) a-Mecha.	—	▶▶	◀◀	▶	●▶	■	▶▶	—	—	—	—	—	—	—	—
COMP-SEL (STOP)	—	▶▶	◀◀	▶	●▶	■	▶▶	—	—	—	—	—	—	—	—
RELAY PLAY	—	▶▶	◀◀	▶	●▶	■	▶▶	—	—	—	—	—	—	—	—
STOP (■) a-Mecha.	—	▶▶	◀◀	▶	●▶	■	▶▶	—	—	—	—	—	—	—	—
AUTO STOP	—	▶▶	◀◀	▶	●▶	■	▶▶	—	—	—	—	—	—	—	—
DUB	—	▶▶	◀◀	▶	●▶	■	▶▶	—	—	—	—	—	—	—	—
COMP-E	—	▶▶	◀◀	▶	●▶	■	▶▶	—	—	—	—	—	—	—	—
PLAYER START	—	▶▶	◀◀	▶	●▶	■	▶▶	—	—	—	—	—	—	—	—
COMP-E	—	▶▶	◀◀	▶	●▶	■	▶▶	—	—	—	—	—	—	—	—

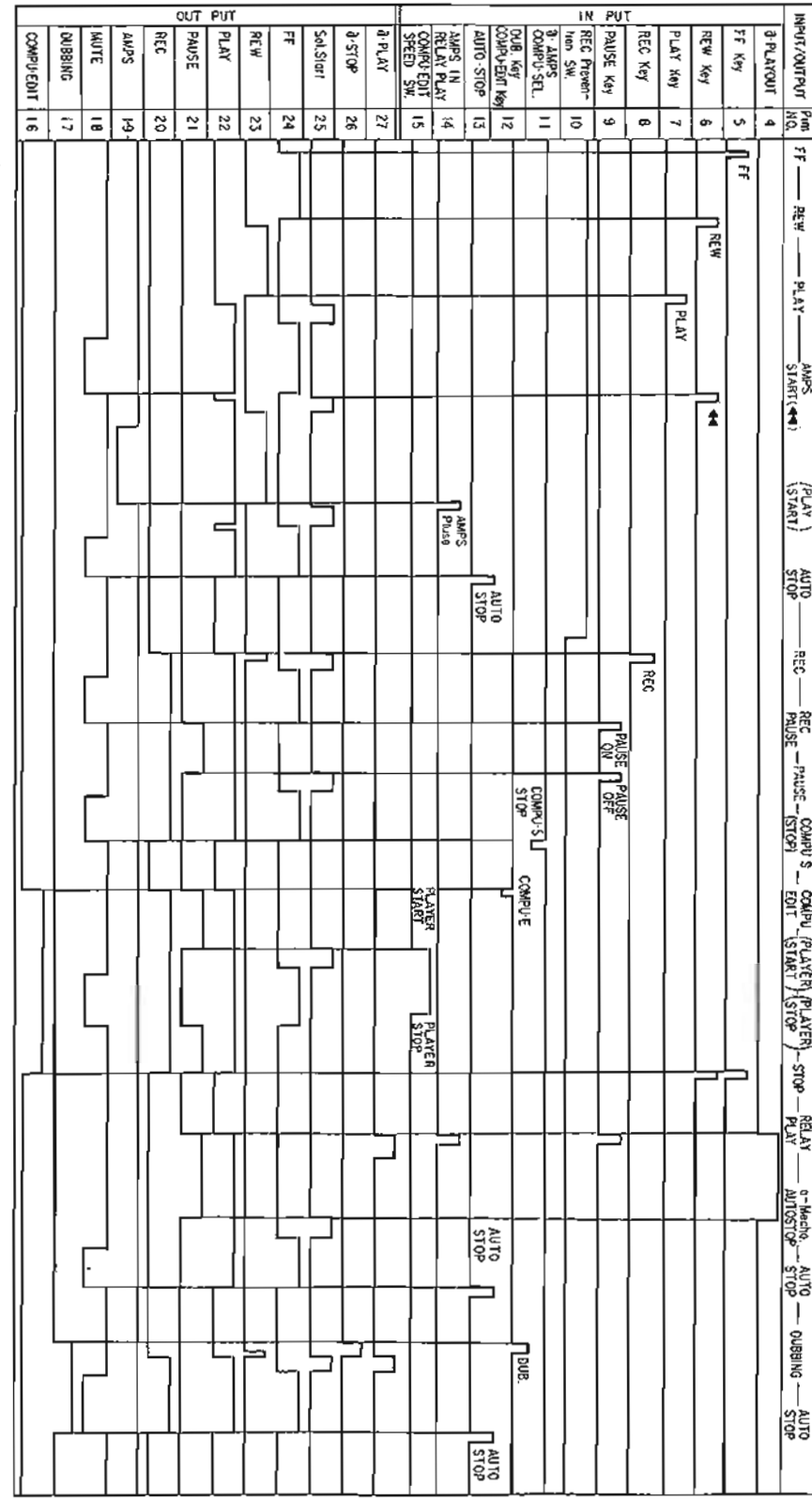

•a-Mecha. Control IC (TC9305P-004, wIC1) Timing chart

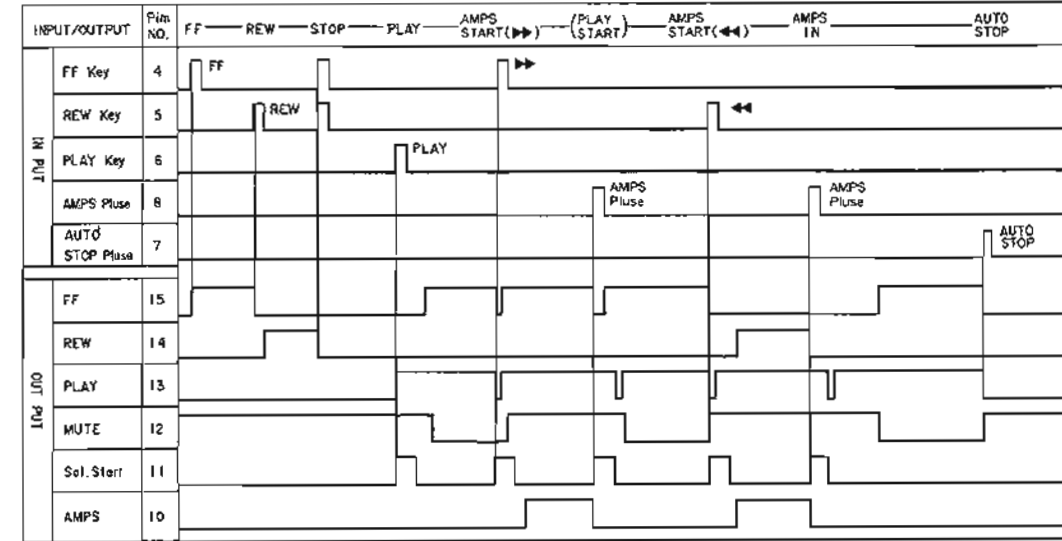

•Mode Change Table of IC TC9305P-004 (wIC1)

Input Key	STOP (■)	PLAY (▶)	FF (▶▶)	REW (◀◀)	AUTO STOP	C.SEL (STOP)	RELAY PLAY	COMP-E	DUB	PLAY (▶) b-Mecha.	C.SEL (PLAY)
PRE MODE	—	—	—	—	—	—	—	—	—	—	—
STOP (■)	—	▶	▶▶	◀◀	■	—	—	—	—	—	—
PLAY (▶)	■	—	▶▶	◀◀	■	—	—	—	—	—	—
FF (▶▶)	■	▶	—	◀◀	■	—	—	—	—	—	—
REW (◀◀)	■	▶	▶▶	—	■	—	—	—	—	—	—
AMPS (FF)	■	▶	—	◀◀	■	—	—	—	—	—	—
AMPS (REW)	■	▶	▶▶	—	■	—	—	—	—	—	—

3. OPERATIONS OF PINCH ROLLER

3-1. Torque Transportation Flowchart

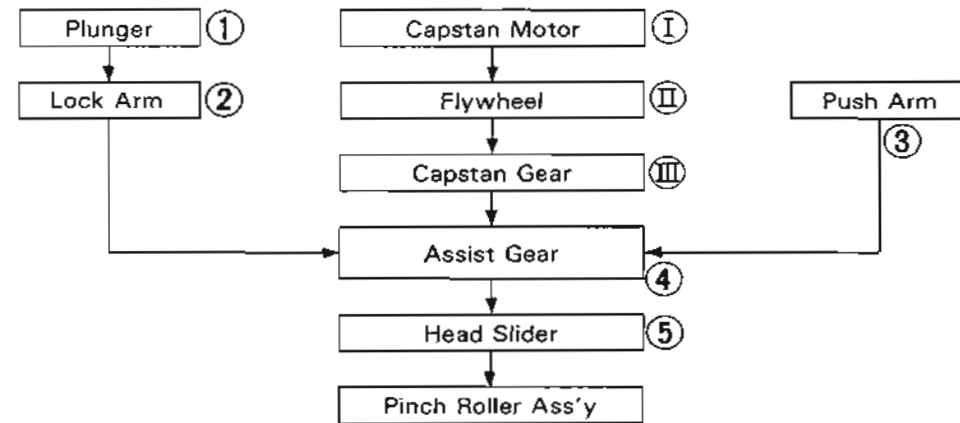

•The pinch roller is brought into pressure contact with the capstan shaft.

3-2. Rear View of Mechanism Chassis

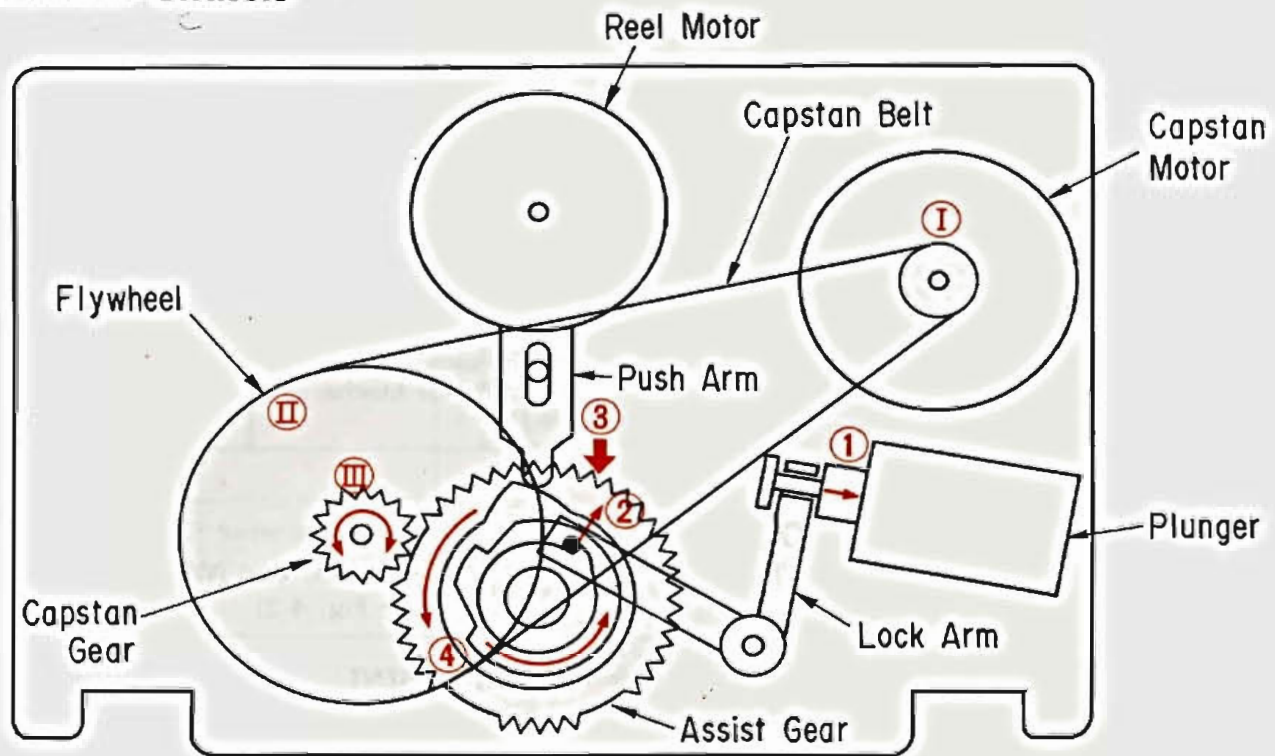

3-3. Front View of Mechanism Chassis

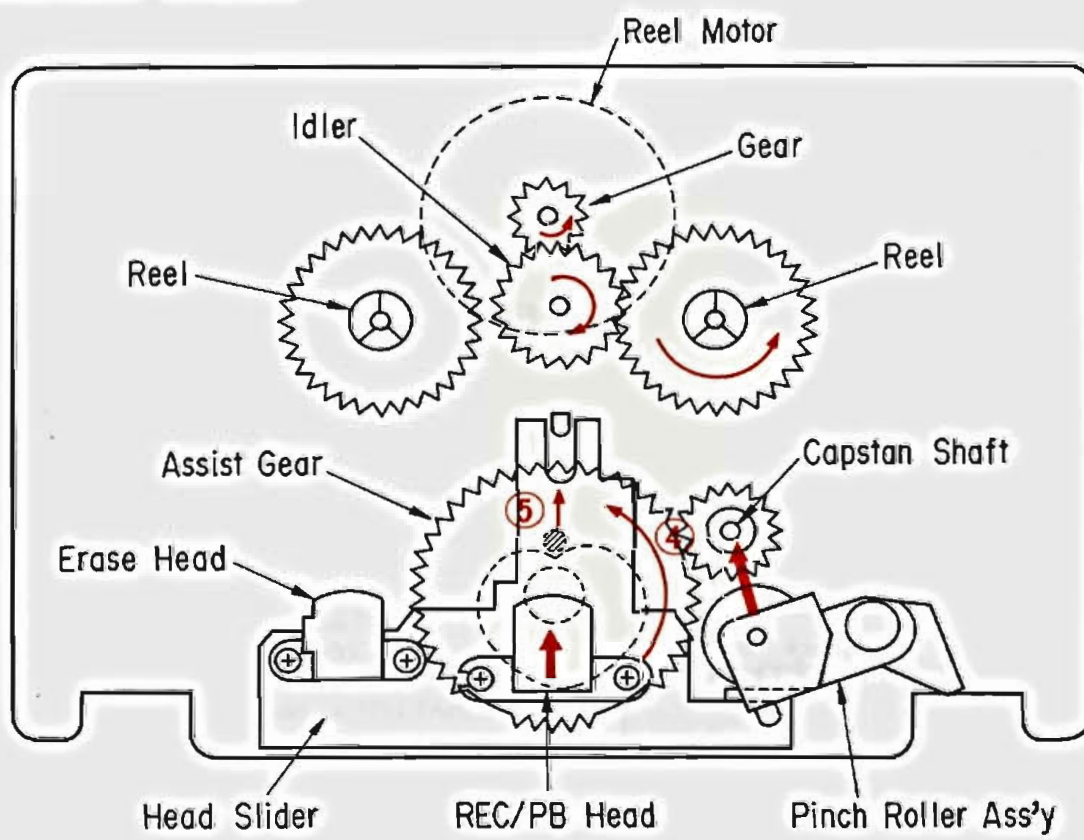

3-4. Cam Positions in the Modes of PLAY, FF, REW & STOP

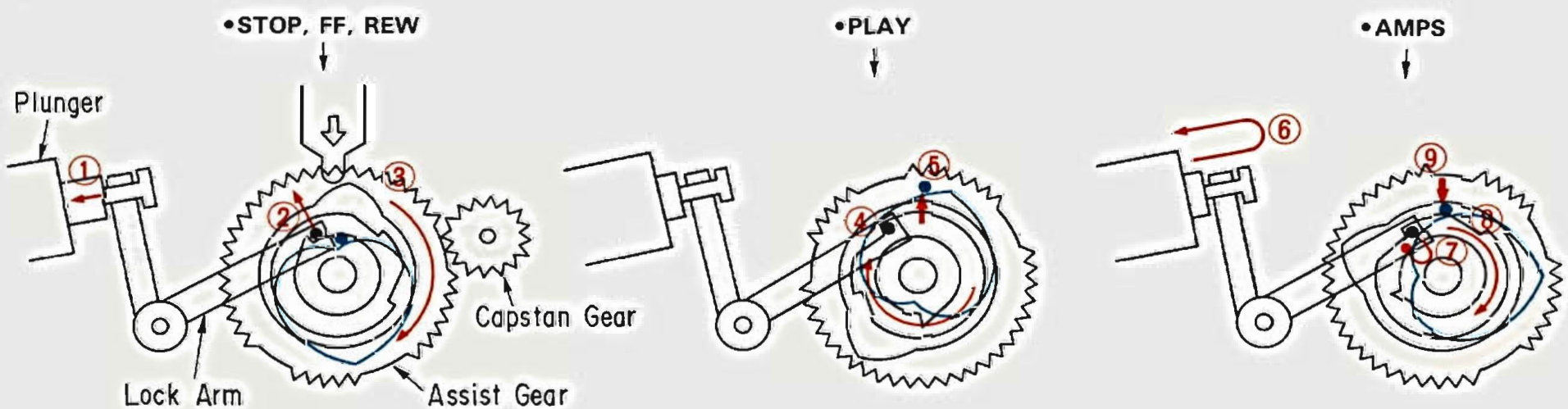

4. ADJUSTMENTS

4-1. Tape Speed Adjustment

- Adjust the tape speed of b-side as fast as a-side.
- Note:** 1. Use Sansui Test Tape, SCT-3SK
(3 kHz signals are recorded on the tape).
2. Connections are shown in Fig. 4-1.

Fig. 4-1

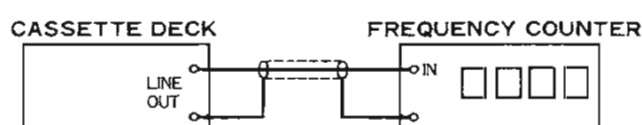
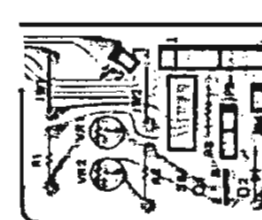

Fig. 4-2

< F-3748 >



1) Tape Speed Adjustment (NORMAL SPEED)

STEP	SUBJECT	MEASURE OUTPUT	SETTING	ADJUSTMENT	ADJUST FOR	REMARKS
1.	A-Side Mecha. (NORMAL)	LINE OUT Frequency counter	Playback the TEST TAPE SCT-S3K. A-Side Mecha.	Turn semi-variable resistor (tVR1) of A-Side Mecha. as Fig. 4-2.	3000Hz ± 30Hz	Use small screw driver.
2.	B-Side Mecha. (NORMAL)		Playback the TEST TAPE SCT-S3K. B-Side Mecha.	Turn semi-variable resistor (tVR1) of B Side Mecha. as Fig. 4-2.	3000Hz ± 30Hz	

2) Tape Speed Adjustment (HIGH SPEED)

- Note:** 1. Before this adjustment, regulate "4-1. Tape Speed Adjustment (NORMAL SPEED)"
2. Short between jW2 (Cross Conductor) & R3 (Resistor) on F-3748. (See Fig. 4-2)

STEP	SUBJECT	MEASURE OUTPUT	SETTING	ADJUSTMENT	ADJUST FOR	REMARKS
1.	A-Side Mecha. (HIGH)	LINE OUT Frequency counter	Playback the TEST TAPE SCT-S3K. A-Side Mecha.	Turn semi-variable resistor (tVR2) of A-Side Mecha. as Fig. 4-2.	6000Hz ± 60Hz	Use small screw driver.
2.	B-Side Mecha. (HIGH)		Playback the TEST TAPE SCT-S3K. B-Side Mecha.	Turn semi-variable resistor (tVR2) of B-Side Mecha. as Fig. 4-2.	6000Hz ± 60Hz	

•Torque of this model: PLAY 30g·cm ~ 60 g·cm
FF, REW..... more than 80 g·cm

4-2. Playback Adjustment

- Note:** 1. Before this adjustment, clean REC/P.B. head surface.
2. For this adjustment, use Sansui Test Tape, SCT-F10K, and SCT-L400.
3. Set the Dolby NR switch to be OFF.
4. Connections are shown in Fig. 4-3.

Fig. 4-3

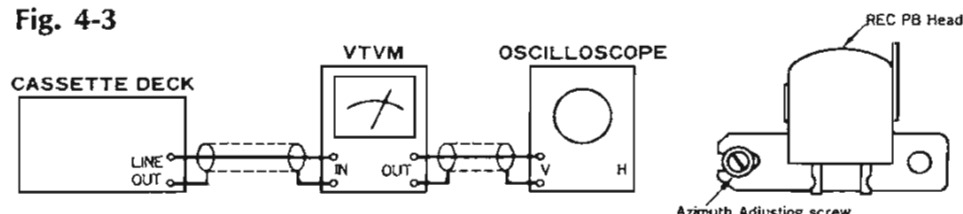

1) b-Side Mecha. Adjustment

STEP	SUBJECT	MEASURE OUTPUT	SETTING	ADJUSTMENT	ADJUST FOR	REMARKS
1.	P.B. Head Adj.	LINE OUT VTVM and Scope	Playback the TEST TAPE SCT-F10K	Adjust the azimuth adjusting screw in Fig. 4-3.	MAX. Output both channels.	Refer to removal of Lid Ass'y on Page 18. After this adjustment, lock the screw with paint.
2.	Playback Level Adj.	Same as above	Playback the TEST TAPE SCT-L400	Adjust each vVR1 (L-CH and R-CH, F-4498)	340mV	See Top View on Page 13.

2) a-Side Mecha. Adjustment

- Note:** Before this adjustment, regulate "4-2. 1) b-side Mecha. Adjustment."

STEP	SUBJECT	MEASURE OUTPUT	SETTING	ADJUSTMENT	ADJUST FOR	REMARKS
1.	REC/P.B. Head Adj.	LINE OUT VTVM and Scope	Playback the TEST TAPE SCT-F10K	Adjust the azimuth adjusting screw in Fig. 4-3.	MAX. Output both channels.	Refer to removal of Lid Ass'y on Page 18. After this adjustment, lock the screw with paint.
2.	Playback Level Adj.	Same as above	Playback the TEST TAPE SCT-L400	Adjust each vVR101 (L-CH and R-CH, F-4430)	340mV	See Top View on Page 13.

4-3. REC Level & Frequency Response Adjustment

< b Side Mecha. only >

Fig. 4-4

- Note:** 1. Connections are shown in Fig. 4-4.
 2. Set the Dolby NR switch to be C.
 3. Short between TP terminal pins on F-4492 (See Top View on page 13).

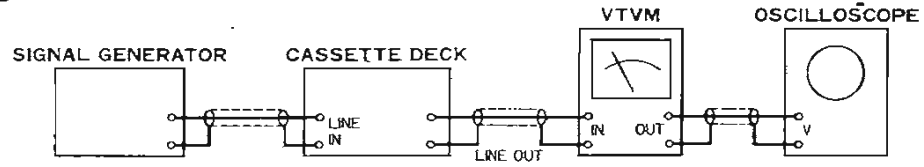

STEP	SUBJECT	INPUT SIGNAL	MEASURE OUTPUT	SETTING	ADJUSTMENT	REMARKS
1.	REC Level Adj.	Feed 1 kHz, from Audio S.G. into LINE IN.	LINE OUT, VTVM and Scope	Load the TEST TAPE SCT-SA. 1. Push the PAUSE, and REC knob. 2. Adjust the output level of Audio SG. for obtaining 20 mV on VTVM. 3. Push the PAUSE knob, then record the 1kHz signal. 4. Play back the 1kHz signal. 5. Confirm that the output levels on both channels are 20 mV ± 2dB on VTVM.	1. If not, turn vVR202 (REC, L-CH, F-4431) and vVR202 (REC, R-CH, F-4431) until output level 20mV ± 2 dB on both channels are obtained.	vVR202 (REC, L-CH), and vVR202 (REC, R-CH) are shown in Top View on page 13.
2.	Frequency Response Adj.	Feed 1kHz 10mV and 10kHz 10mV, from Audio S.G. into LINE IN.	Same as above	Load the TEST TAPE SCT-SA. 1. Record the 1kHz and 10kHz signals. 2. Play back the 1kHz and 10 kHz signals, then confirm that both output levels equal.	1. If not, adjust vVR203 (F-4431) for L-CH and vVR203 (F-4431) for R-CH slightly until the output levels will be equal.	vVR203 (BIAS, L-CH) and vVR203 (BIAS, R-CH) are shown in Top View on page 13.
3.	REC Level Adj.	Feed 1kHz, from Audio S.G. into LINE IN.	LINE OUT, VTVM and Scope	Load the TEST TAPE SCT-MA. 1. Push the PAUSE, and REC knob. 2. Adjust the output level of Audio SG. for obtaining 20mV on VTVM. 3. Push the PAUSE button, the record the 1kHz signal. 4. Play back the 1kHz signal. 5. Confirm that the output levels on both channels are 20mV ± 2dB on VTVM.	1. If not, turn vVR201 (METAL, L-CH, F-4431) and vVR201 (METAL, R-CH, F-4431) until output level 20mV ± 2dB on both channels are obtained.	vVR201 (METAL, L-CH), and vVR201 (METAL, R-CH) are shown in Top View on page 13.

4-4. Dubbing Level Balance Adjustment

- Note:** 1. Before this adjustment, clean REC/P.B. head surface.
 2. For this adjustment, use Sansui Test Tape SCT-L400.
 3. Set the Dolby NR switch to be OFF.
 4. Connections are shown in Fig. 4-3.

STEP	SUBJECT	MEASURE OUTPUT	SETTING	ADJUSTMENT	ADJUST FOR	REMARKS
1.	Dubbing Level Balance Adj.	LINE OUT VTVM and Scope.	1. Load the TEST TAPE SCT-L400 at a side mecha. 2. Load the TEST TAPE SCT-SA at b-side mecha. 3. Push the a-side PLAY knob. 4. Push the b-side REC knob.	Turn each vVR2 (L-CH & R-CH, F-4500)	340mV	vVR2 (L-CH & R-CH) are shown in Top View on page 13.

◆ List of Sansui Test Tape

Name of TEST TAPE	Recorded Frequency	Description	Equivalent To
SCT-F40	40 Hz	Playback Frequency Response Check	—
SCT-F1K	1 kHz	High Frequency Equalization Check	—
SCT-F10K	10 kHz	REC/PB Head Adjustment	—
SCT-L400	400 Hz	Playback Level and Indicator Level Adjustment	—

Name of TEST TAPE	Recorded Frequency	Description	Equivalent To
SCT-S3K	3 kHz	Speed Check and Wow & Flutter Check	—
*SCT-AD (NORMAL)	—	Recording Bias Adjustment	TDK AD
*SCT-SA (HIGH)	—	REC/PB Level Adjustment	TDK SA
*SCT-MA (METAL)	—	Frequency Response Check	TDK MA

•Note: Some reference tapes marked * are not supplied.
 As these are equivalent to ones indicated above, please obtain these blank tapes on your side as possible.

5. PARTS LOCATION & PARTS LIST

5-1. F-4422 Noise Reduction Circuit Board (Stock No. 00775301)

Component Side

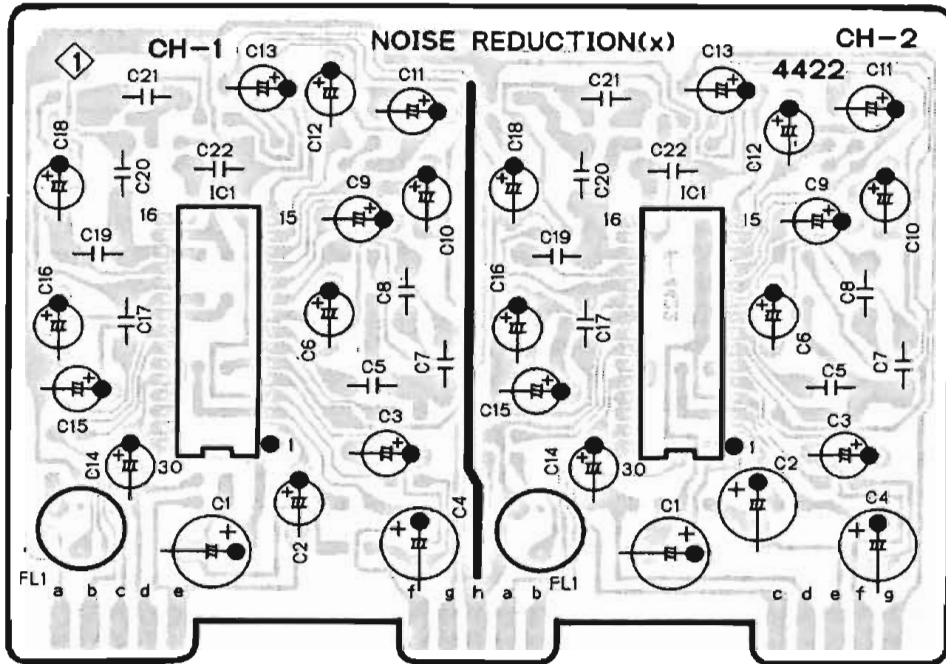

Parts List

Parts No.	Stock No.	Description
xJW1	46741100	Cross Conductor (Chip)
xJW2	46741100	Cross Conductor (Chip)
xJW3	46741100	Cross Conductor (Chip)
xJW4	46741100	Cross Conductor (Chip)
xJW5	46741100	Cross Conductor (Chip)
xR1	46754000	470kΩ 1/8W Chip R.
xR2	46749400	5.6kΩ 1/8W Chip R.
xR4	46749800	8.2kΩ 1/8W Chip R.
xR5	46748800	3.3kΩ 1/8W Chip R.
xR6	46750900	24kΩ 1/8W Chip R.
xR7	46749500	6.2kΩ 1/8W Chip R.
xR8	46752200	82kΩ 1/8W Chip R.
xR9	46754800	1MΩ 1/8W Chip R.
xR10	46752200	82kΩ 1/8W Chip R.
xR11	46752200	82kΩ 1/8W Chip R.

Pattern Side (Chip Resistor, Cross Conductor)

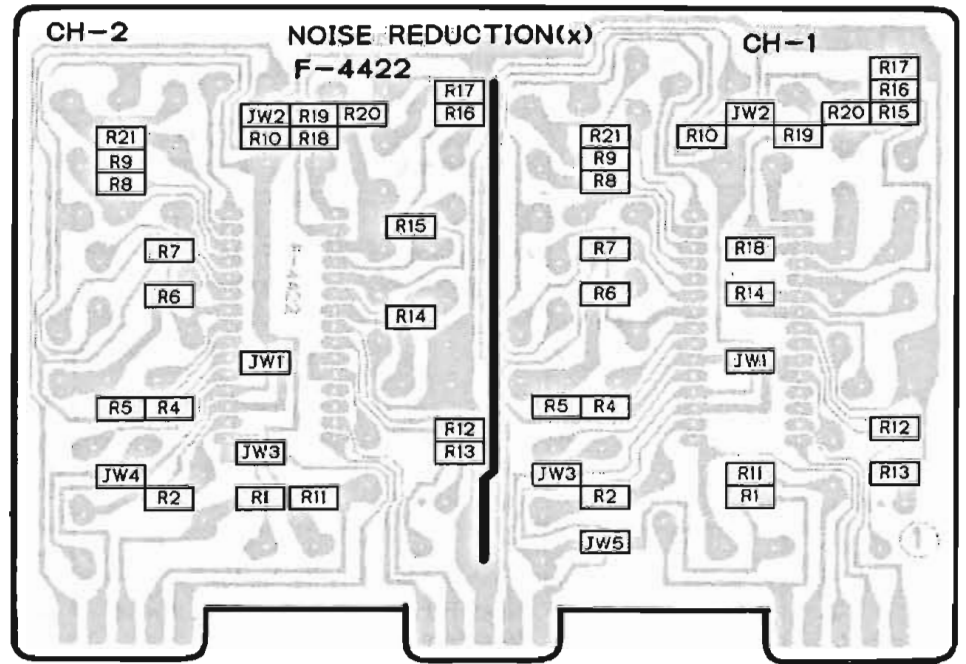

•Note In this model, "CH-1" side of this circuit board is the left channel.

Parts No.	Stock No.	Description
xR12	46748800	3.3kΩ 1/8W Chip R.
xR13	46747600	1kΩ 1/8W Chip R.
xR14	46752200	82kΩ 1/8W Chip R.
xR15	46749500	6.2kΩ 1/8W Chip R.
xR16	46752200	82kΩ 1/8W Chip R.
xR17	46746800	470Ω 1/8W Chip R.
xR18	46749200	4.7kΩ 1/8W Chip R.
xR19	46750000	10kΩ 1/8W Chip R.
xR20	46752000	68kΩ 1/8W Chip R.
xR21	46754800	1MΩ 1/8W Chip R.
•IC		
xIC1	46671900	HA12058NT
xFL1	46177600	Dolby Filter (19.8 kHz)

5-2. F-4431 Rec Amp. Circuit Board (Stock No. 00791401)

Component Side

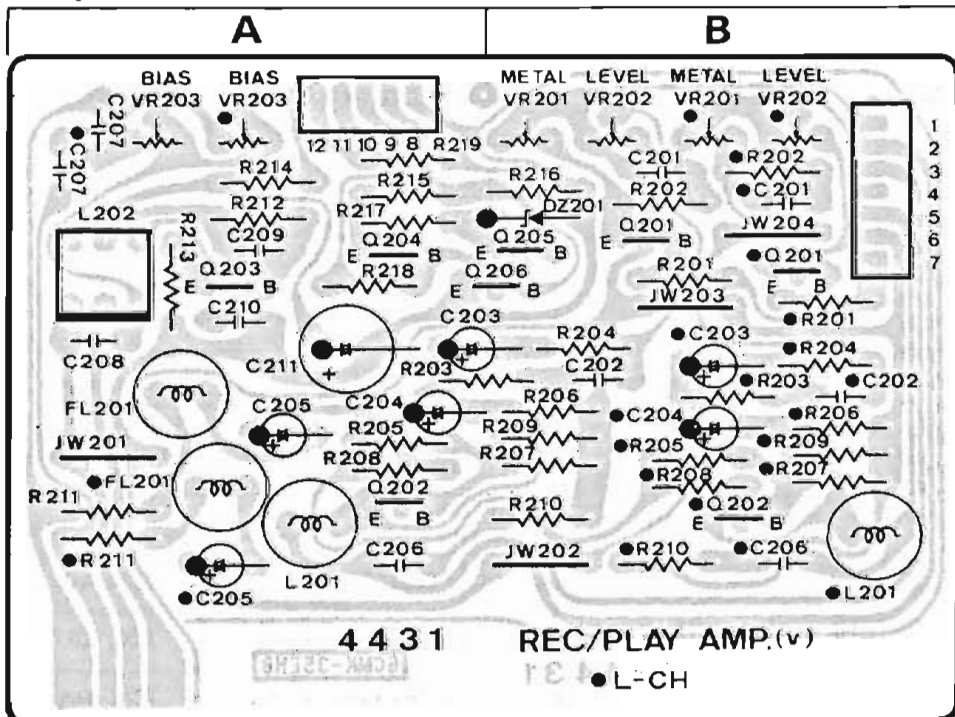

•Note: On this circuit board, the left channel is specified by "●" mark on top of the parts No.

Parts List

Parts No.	Stock No.	Description
•Transistor		
vQ201	46367101	2SC2603
	or 46391901	2SC2785
vQ202	46367101	2SC2603
	or 46391901	2SC2785
vQ203	46725801	2SC1627A
vQ204	03086101	2SD357
vQ205	46367101	2SC2605
	or 46391901	2SC2785
vQ206	46367101	2SC2603
	or 46391901	2SC2785
•Zener Diode		
vDZ201	46109400	05Z 3.0-Y
vC208	46657000	3900pF 100V F.C.
vFL201	42904400	Peaking Coil
vL201	46314000	Inductor 3.3mH
vL202	46362200	Bias OSC Coil
vVR201	07262100	50kΩ(B) S.V.R., rec level adj. (METAL)
vVR202	07262100	50kΩ(B) S.V.R., rec level adj. (HIGH, NORMAL)
vVR203	07262200	100kΩ(B) S.V.R., bias adj.

5-3. F-4430 Play Amp. Circuit Board

(Stock No. 00791301)

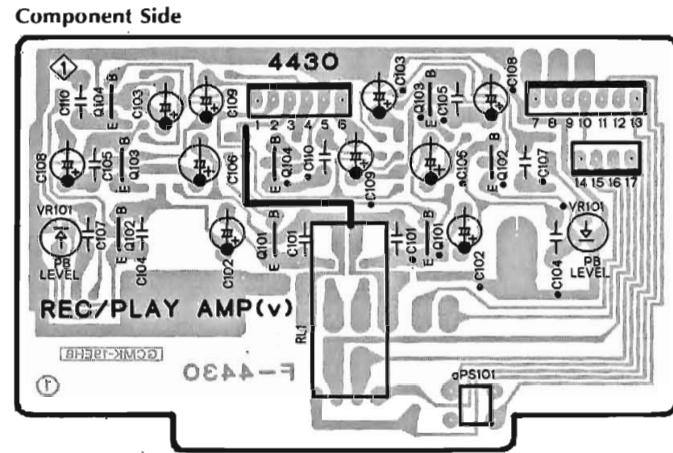

•Note: On this circuit board, the right channel is specified by "•" mark on top of the parts No.

Pattern Side (Chip Resistor)

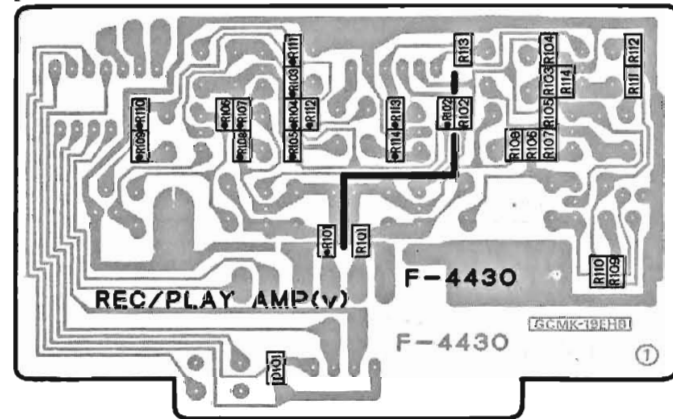

Parts List

Parts No.	Stock No.	Description
•Transistor		
vQ101	46359801	2SC2001 (b-Side only)
vQ102	46577801	2SC2320L
vQ103	46577801	2SC2320L
vQ104	46367101	2SC2603
	or 46391901	2SC2785
•Diode		
vD101	46852000	RLS-73
vR101	46742800	10Ω 1/8W Chip R
vR102	46749200	4.7kΩ 1/8W Chip R
vR103	46753200	220kΩ 1/8W Chip R
vR104	46751600	47kΩ 1/8W Chip R
vR105	46750400	15kΩ 1/8W Chip R
vR106	46753200	220kΩ 1/8W Chip R
vR107	46744000	33Ω 1/8W Chip R
vR108	46747800	1.2kΩ 1/8W Chip R
vR109	46746800	470Ω 1/8W Chip R
vR110	46752800	150kΩ 1/8W Chip R
vR111	46748600	2.7kΩ 1/8W Chip R
vR112	46748400	2.2kΩ 1/8W Chip R
vR113	46750800	22kΩ 1/8W Chip R
vR114	46753200	220kΩ 1/8W Chip R
vVR101	46839300	1kΩ S.V.R., PB. Level adj.
vRL1	11504700	Relay (b-Side only)
	or 11504701	Relay LR2A-12B (b-Side only)

5-4. F-4491 Audio Main Circuit Board (Stock No. 00790301)

Component Side

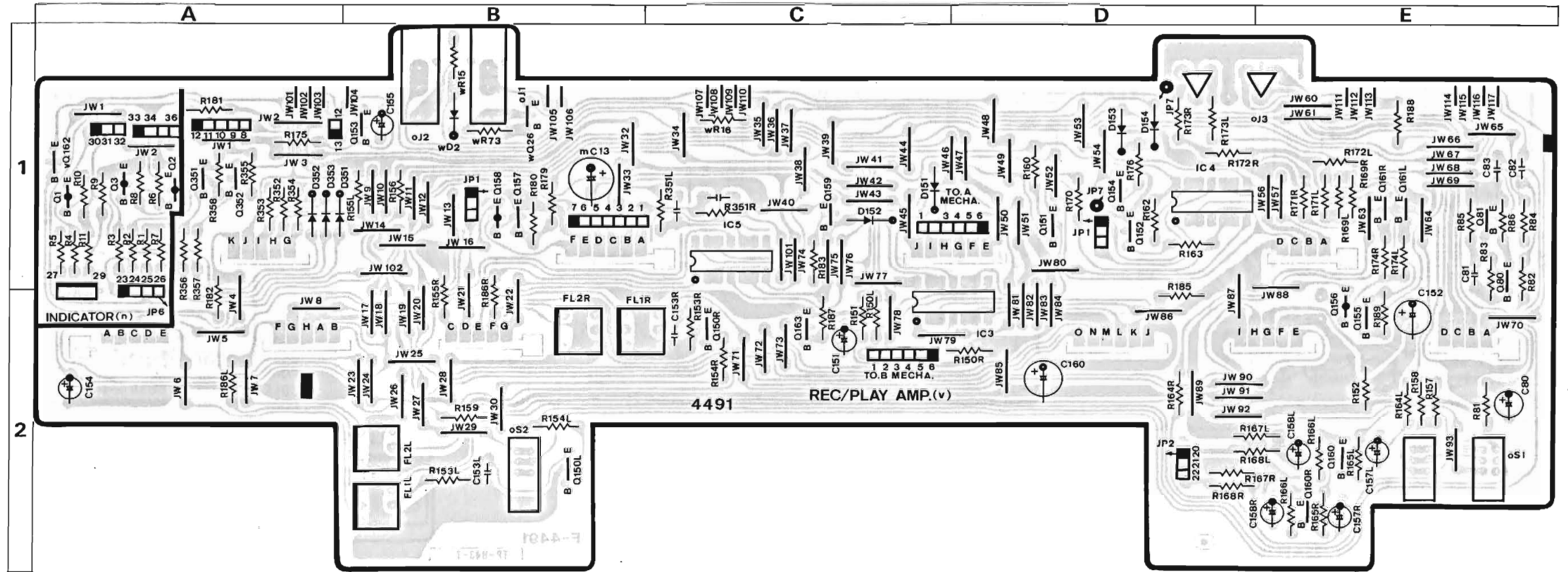

Parts List

Parts No.	Stock No.	Description
•Transistor		
nQ1	46367001	2SA1115
	or 46392001	2SA1175
nQ2	46367001	2SA1115
	or 46392001	2SA1175
nQ3	46367001	2SA1115
	or 46392001	2SA1175
oS1	46430600	Push SW., DOLBY NR
oS2	46365300	Push SW., SPEED
oJ1	46547200	Jack, COMPU SELECTOR
oJ2	46547200	Jack, COMPU EDIT
oJ3	46371500	4P Terminal, LINE IN/OUT
•Transistor		
vQ80	46367101	2SC2603
	or 46391901	2SC2785
vQ81	46367101	2SC2603
	or 46391901	2SC2785
vQ150	46367101	2SC2603
	or 46391901	2SC2785
vQ151	46367101	2SC2603
	or 46391901	2SC2785
vQ152	46367101	2SC2603
	or 46391901	2SC2785
vQ153	46367101	2SC2603
	or 46391901	2SC2785
vQ154	46367101	2SC2603
	or 46391901	2SC2785
vQ155	46367101	2SC2603
	or 46391901	2SC2785
vQ156	46719800	DTA124
vQ157	46367101	2SC2603
	or 46391901	2SC2785
vQ158	46719800	DTA124

Parts No.	Stock No.	Description
vQ159	46367101	2SC2603
	or 46391901	2SC2785
vQ160	46367101	2SC2603
	or 46391901	2SC2785
vQ161	46367101	2SC2603
	or 46391901	2SC2785
vQ162	46367101	2SC2603
	or 46391901	2SC2785
vQ163	46367101	2SC2603
	or 46391901	2SC2785
vQ351	46367101	2SC2603
	or 46391901	2SC2785
vQ352	46367101	2SC2603
	or 46391901	2SC2785
•IC		
viC3	46255000	LC4066BH
	or 46421000	μPD4066BC
viC4	46255000	LC4066BH
	or 46421000	μPD4066BC
viC5	46255000	LC4066BH
	or 46421000	μPD4066BC
•Diode		
vD151	03117600	1S2473T77
	or 46086000	1S1588TP-3
vD152	03117600	1S2473T77
	or 46086000	1S1588TP-3
vD153	03117600	1S2473T77
	or 46086000	1S1588TP-3
vD154	03117600	1S2473T77
	or 46086000	1S1588TP-3
vD351	03117600	1S2473T77
	or 46086000	1S1588TP-3
vD352	03117600	1S2473T77
	or 46086000	1S1588TP-3

Parts No.	Stock No.	Description
vD353	03117600	1S2473T77
	or 46086000	1S1588TP-3
vFL1	46177500	Dolby Filter
	or 46177501	Dolby Filter
vFL2	46935500	Low Pass Filter
ΔvR155	08922100	22Ω 1/2W N.I.R.
•Transistor		
wQ26	46367001	2SA1115
	or 46392001	2SA1175
•Diode		
wD2	03117600	1S2473T77
	or 46086000	1S1588TP-3

5-5. F-4494 AMPS Indicator Board

Component Side

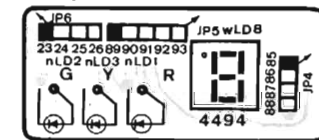

Parts List

Parts No.	Stock No.	Description
•LED		
nLD1	46176900	TLS-123
nLD2	07250900	TLG-123A
nLD3	07251000	TLY-123
wLD8	46917700	GL-8P03D

5-6. F-4492 Control & Power Supply Circuit Board (Stock No. 00790401)

Component Side

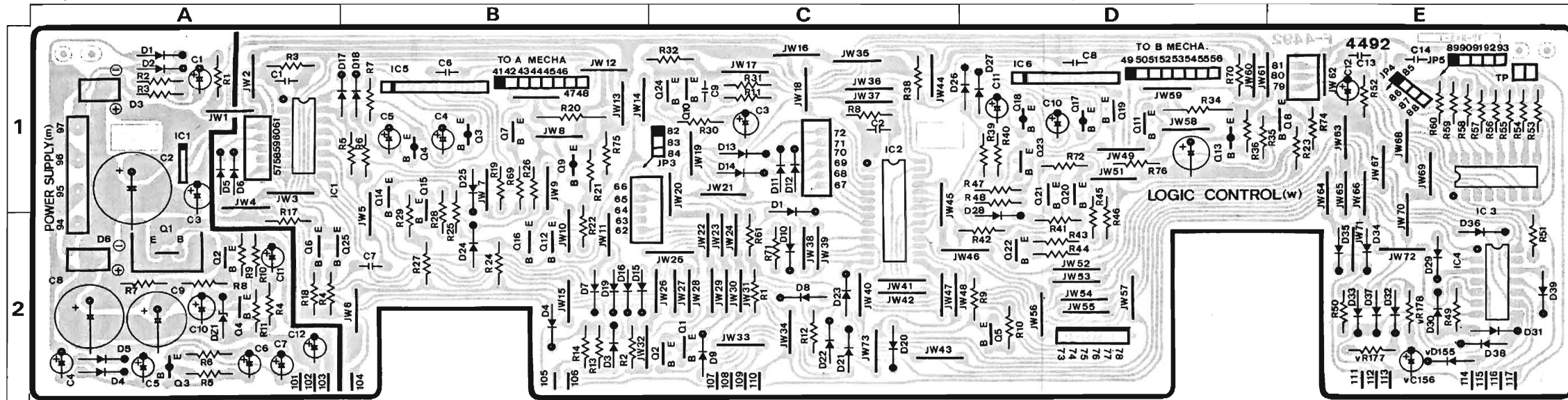

Parts List

Parts No.	Stock No.	Description
•Transistor		
△mQ1	03083901	2SD313AL
△mQ2	46367101	2SC2603
	or 46391901	2SC2785
△mQ3	46367001	2SA1115
	or 46392001	2SA1175
mQ4	46367101	2SC2603
	or 46391901	2SC2785
•IC		
△mIC1	46361200	L78N06
•Diode		
mD1	03117600	1S2473T77
	or 46086000	1S1588TP-3
△mD2	03117600	1S2473T77
	or 46086000	1S1588TP-3
△mD3	46273600	DBB10-B
△mD4	03117600	1S2473T77
	or 46086000	1S1588TP-3
△mD5	03117600	1S2473T77
	or 46086000	1S1588TP-3
△mD6	46273600	DBB10-B
•Zener Diode		
mDZ1	46111500	05Z 5.6-Y
•Diode		
vD155	03117600	1S2473T77
	or 46086000	1S1588TP-3
vc156	08451000	10μF 16V E.B.
•Transistor		
wQ1	46367101	2SC2603
	or 46391901	2SC2785
wQ2	46367101	2SC2603
	or 46391901	2SC2785
wQ3	46719800	DTA124
wQ4	46719800	DTA124
wQ5	46367101	2SC2603
	or 46391901	2SC2785
wQ6	46367101	2SC2603
	or 46391901	2SC2785
wQ7	46359801	2SC2001
wQ8	46367101	2SC2603
	or 46391901	2SC2785

Parts No.	Stock No.	Description
wQ9	46359701	2SA952
wQ10	46367101	2SC2603
	or 46391901	2SC2785
wQ11	46359801	2SC2001
wQ12	46719900	DTC124
wQ13	46359701	2SA952
wQ14	46367101	2SC2603
	or 46391901	2SC2785
wQ15	46367101	2SC2603
	or 46391901	2SC2785
wQ16	46614101	2SC3243
wQ17	46719800	DTA124
wQ18	46719800	DTA124
wQ19	46614101	2SC3243
wQ20	46367101	2SC2603
	or 46391901	2SC2785
wQ21	46367101	2SC2603
	or 46391901	2SC2785
wQ22	46367101	2SC2603
	or 46391901	2SC2785
wQ23	46367101	2SC2603
	or 46391901	2SC2785
wQ24	46367101	2SC2603
	or 46391901	2SC2785
wQ25	46367101	2SC2603
	or 46391901	2SC2785
•IC		
wIC1	46899500	TC9305P-004
wIC2	46899600	TC9310N-044
wIC3	46369800	TC9138AP
wIC4	03605700	MSM4069RS
	or 07107600	TC4069UBP
	or 46427000	μPD4069UBC
wIC5	46149600	BA6208
wIC6	46149600	BA6208
•Diode		
wD1 ~ 39	03117600	1S2473T77
	or 46086000	1S1588TP-3
△wR20	46624200	82Ω 2W N.I.R.
△wR34	46624200	82Ω 2W N.I.R.
△wR75	08922700	27Ω 1/2W N.I.R.
△wR76	08922700	27Ω 1/2W N.I.R.

5-7. F-4493 PHONES Jack Board

Component Side

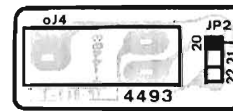

Parts List

Parts No.	Stock No.	Description
oJ4	46265700	Jack, PHONES

5-8. F-4495 Timer SW. Board

Component Side

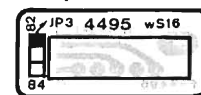

Parts List

Parts No.	Stock No.	Description
wS16	46178400	Slide SW., TIMER

5-9. F-4453 Power SW. Board

Component Side

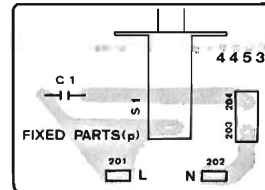

Parts List

Parts No.	Stock No.	Description
△pC1	46425800	0.01μF 400V C.C.
△pS1	46360300	Push SW., POWER
△pZ1	38005400	Power Supply Cord (XX, CSA)
△	38004700	Power Supply Cord (UL)
△	38004500	Power Supply Cord (EU)
△	38004300	Power Supply Cord (BS)

5-10. F-3748 Speed Control Circuit Board

Component Side

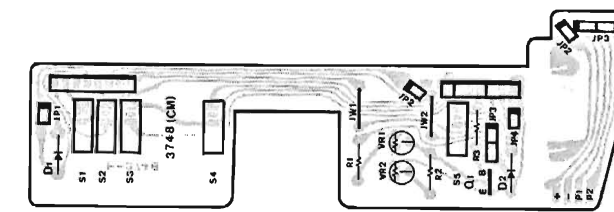

Parts List

Parts No.	Stock No.	Description
•Transistor		
tQ1	07206901	2SC-2001-L
•Diode		
tD1	03111600	1S2473D
tVR1	46839500	4.7kΩ S.V.R., NORMAL SPEED
tVR2	46839600	10kΩ S.V.R., HIGH SPEED
tS1	47292700	Leaf SW., half
tS2	47292700	Leaf SW., REC Prevention (b-Mecha.)
tS3	47292700	Leaf SW., tape sel. HIGH
tS4	47292700	Leaf SW., tape sel. METAL (b-Mecha.)

5-11. F-4497 Mecha. Control SW. Board

Component Side

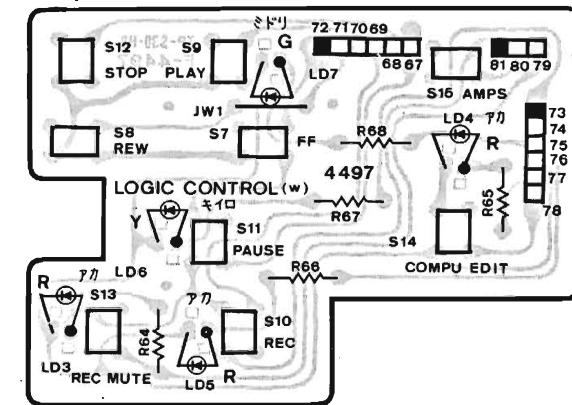

Parts List

Parts No.	Stock No.	Description
•LED		
wLD3	46176900	TLS-123
	or 46470200	SEL2210S
wLD4	46176900	TLS-123
	or 46470200	SEL2210S
wLD5	46176900	TLS-123
	or 46470200	SEL2210S
wLD6	07251000	TLY-123
	or 46470400	SEL2910A
wLD7	07250900	TLG-123A
	or 46470300	SEL2410E
wS7	46549500	Push SW., FF
wS8	46549500	Push SW., REW
wS9	46549500	Push SW., PLAY
wS10	46549500	Push SW., REC
wS11	46549500	Push SW., PAUSE
wS12	46549500	Push SW., STOP
wS13	46549500	Push SW., REC MUTE
wS14	46549500	Push SW., COMPU EDIT
wS15	46549500	Push SW., AMPS

5-12. F-4496 a Mecha. Control SW. Board
Component Side

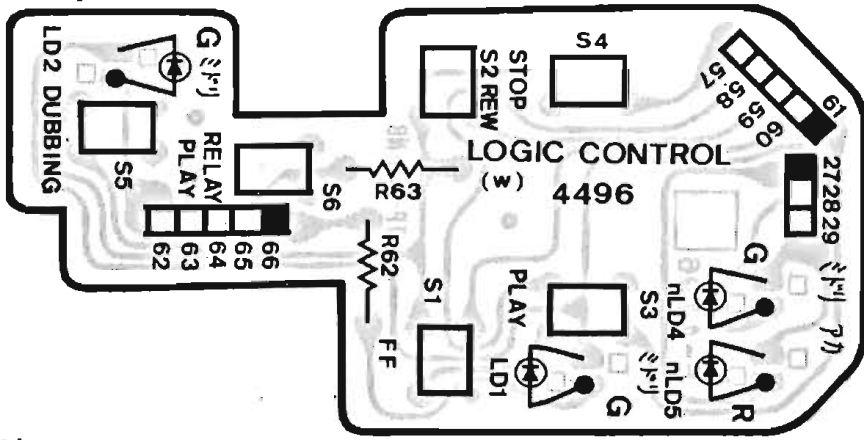

Parts List

Parts No.	Stock No.	Description
•LED		
nLD4	07250900 or 46470300	TLG-123A SEL2410E
nLD5	46176900 or 46470200	TLS-123 SEL2210S
wLD1	07250900 or 46470300	TLG-123A SEL2410E
wLD2	07250900 or 46470300	TLG-123A SEL2410E
wS1	46549500	Push SW., FF
wS2	46549500	Push SW., REW
wS3	46549500	Push SW., PLAY
wS4	46549500	Push SW., STOP
wS5	46549500	Push SW., DUB.
wS6	46549500	Push SW., RELAY

5-14. F-4499 Rec EQ & Rec Mute Circuit Board
Component Side (Stock No. 00791101)

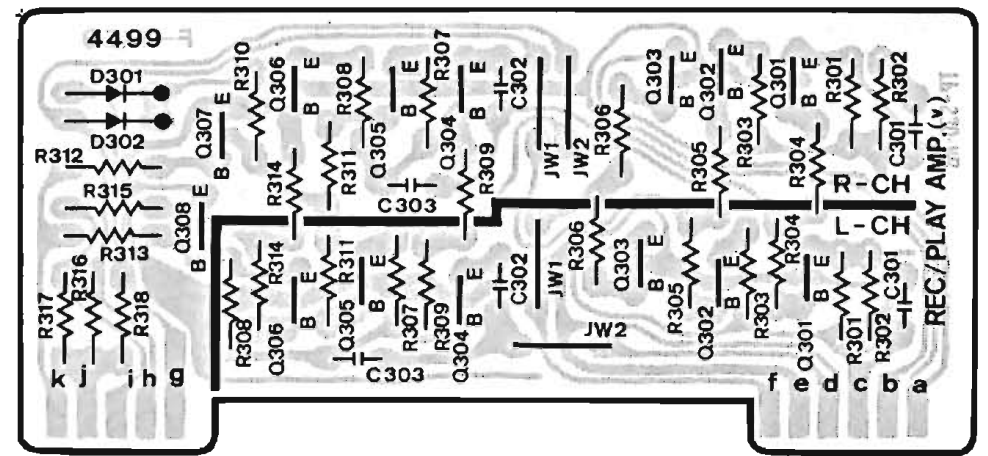

Parts List

Parts No.	Stock No.	Description
•Transistor		
vQ301	46367101 or 46391901	2SC2603 2SC2785
vQ302	46367101 or 46391901	2SC2603 2SC2785
vQ303	46367101 or 46391901	2SC2603 2SC2785
vQ305	46367101 or 46391901	2SC2603 2SC2785
vQ306	46367101 or 46391901	2SC2603 2SC2785
vQ307	46367101 or 46391901	2SC2603 2SC2785
vQ308	46367101 or 46391901	2SC2603 2SC2785
•Diode		
vD301	03117600 or 46086000	1S2473T77 1S1588TP-3
vD302	03117600 or 46086000	1S2473T77 1S1588TP-3

5-13. F-4498 Auto Level Control & Buffer Amp. Circuit Board (Stock No. 00791001)
Component Side

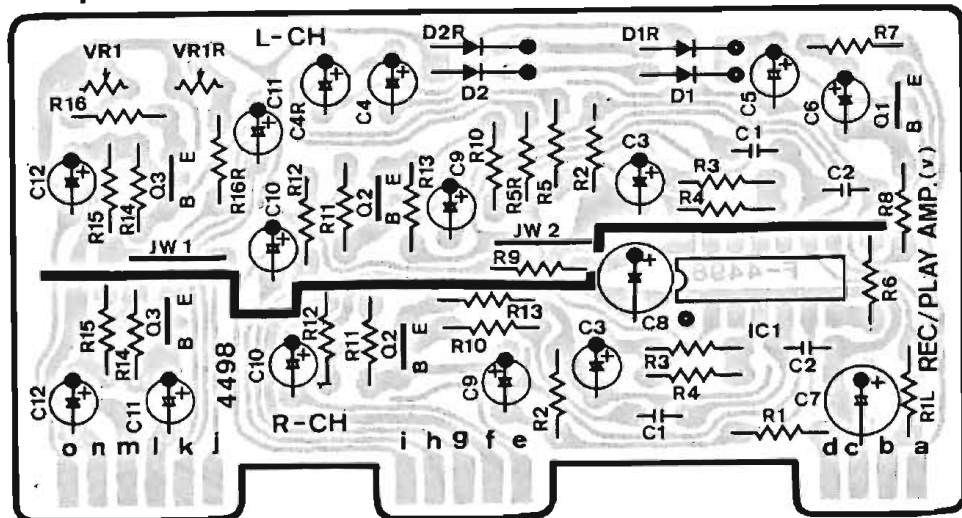

Parts List

Parts No.	Stock No.	Description
•Transistor		
vQ1	46367101 or 46391901	2SC2603 2SC2785
vQ2	46577801 or 46581701	2SC2320L 2SC1845
vQ3	46577801 or 46581701	2SC2320L 2SC1845
•IC		
vIC1	46899000	LA3220
•Diode		
vD1	03117600 or 46086000	1S2473T77 1S1588TP-3
vD2	03117600 or 46086000	1S2473T77 1S1588TP-3
vVR1	07261500	500Ω(B) S.V.R., PB. level adj.

5-15. F-4500 a-side Line Amp. Circuit Board
Component Side (Stock No. 00791201)

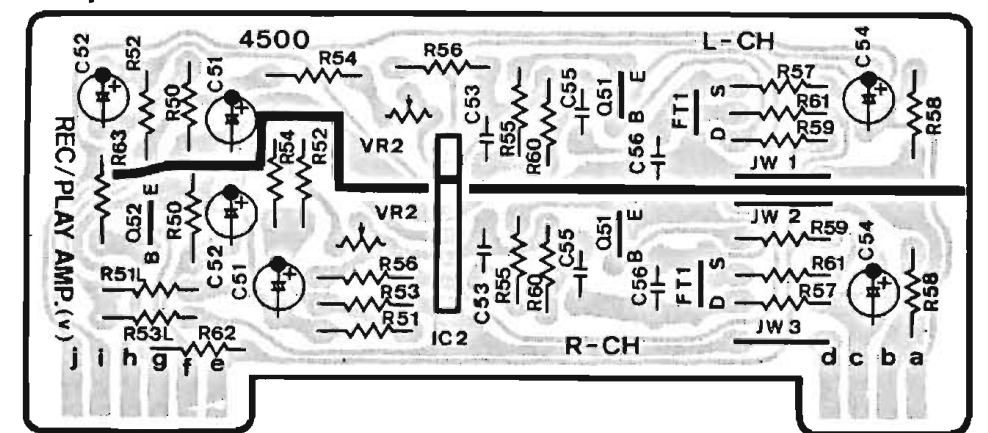

Parts List

Parts No.	Stock No.	Description
•Transistor		
vQ51	46367101 or 46391901	2SC2603 2SC2785
vQ52	46367101 or 46391901	2SC2603 2SC2785
•FET		
vFT1	46643800 or 46643801 or 46643802	2SJ103-Y 2SJ103-GR 2SJ103-BL
•IC		
vIC2	46147700	M5218L
vVR2	07261500	500Ω(B) S.V.R., dubbing level balance adj.

6. EXPLODED VIEW & PARTS LIST

6-1. Front View of Mechanism Chassis

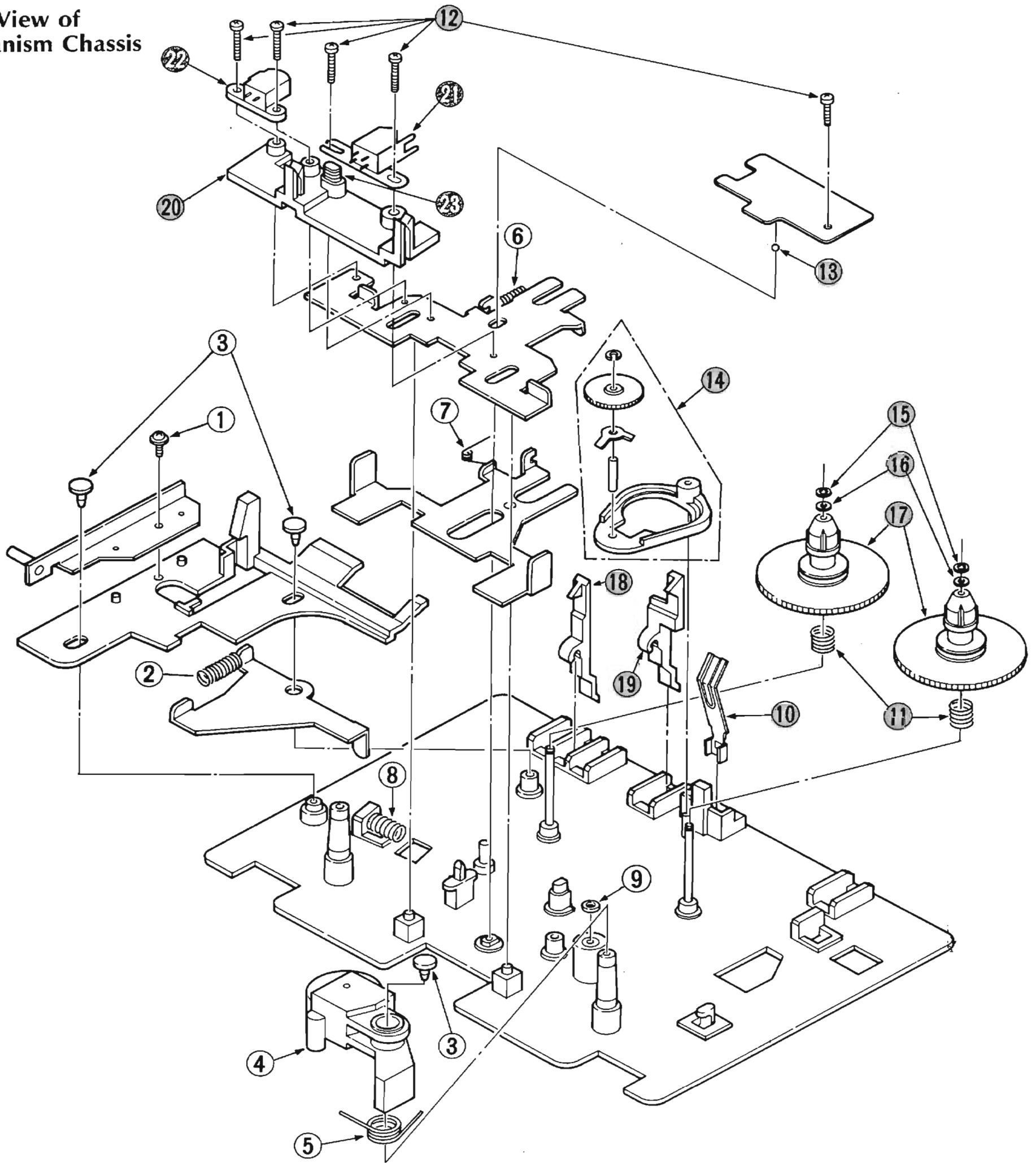

Parts List

Parts No.	Stock No.	Description
1	46731200	Tapping Screw, M2.6×8
2	47406010	Spring, eject
3	47420900	Plastic Tack
4	47281800	Pinch roller Ass'y
5	47483100	Spring, pinch roller
6	47406200	Spring, head base
7	47405600	Spring, slide base
8	47405900	Spring, plunger solenoid
9	47404700	Washer, d=2.5
10	47293510	Spring, half

Parts No.	Stock No.	Description
11	47405700	Spring, reel
12	00420900	Binding Head Screw, M2×12
13	47404900	Steel Ball, φ2.0
14	47405000	Arm Ass'y
15	47404800	Washer, d=1.6
16	47497100	Washer, d=2.0
17	47283400	Reel Gear A
18	47292410	Sensor Arm (A)
19	47292500	Sensor Arm (B)
20	47284100	Head Base

6-2. Rear View of Mechanism Chassis

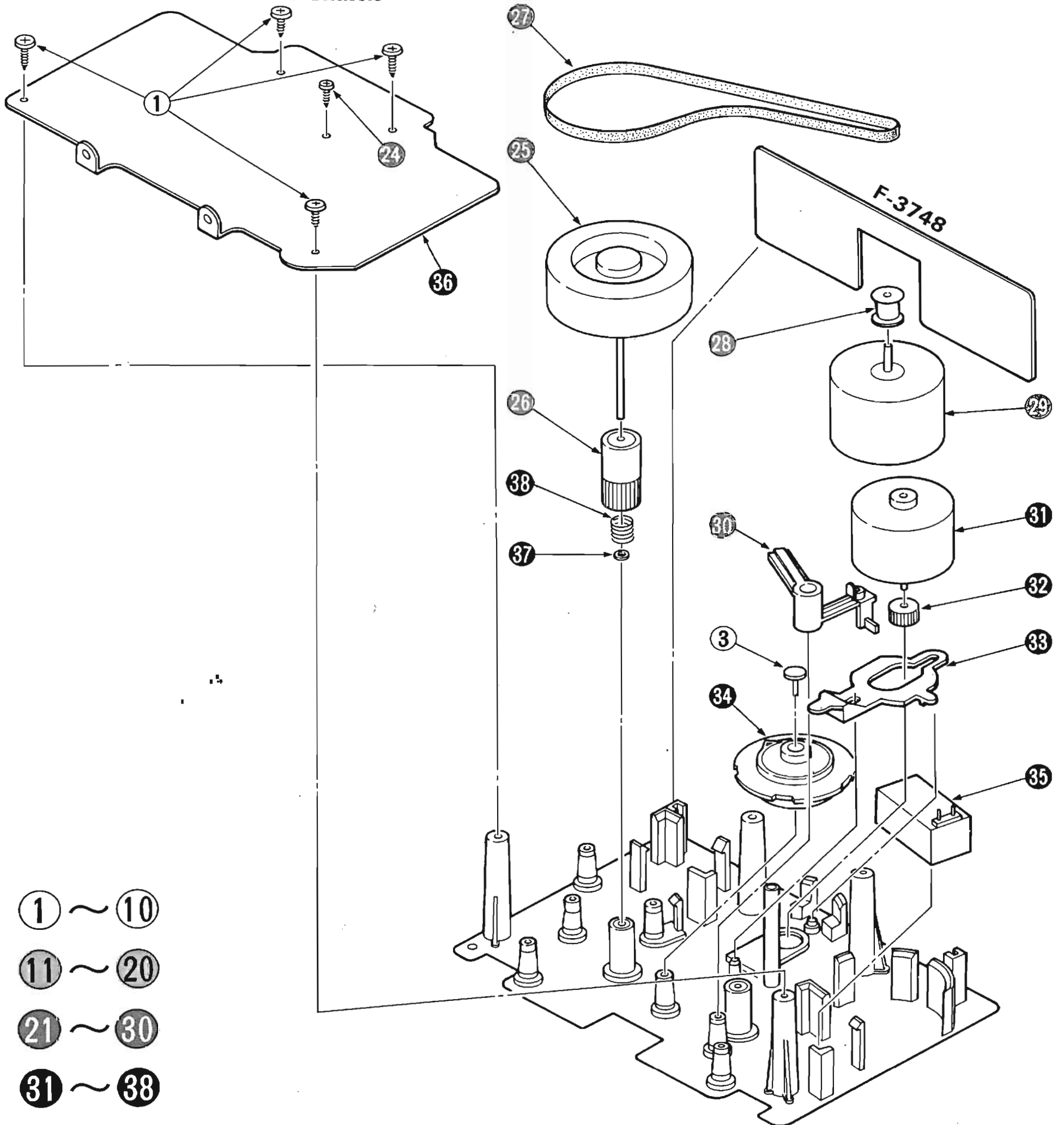

- ① ~ ⑩
- ⑪ ~ ⑳
- ㉑ ~ ㉓㉔
- ㉕ ~ ㉘

Parts No.	Stock No.	Description
21	46920300	REC/PB Head
22	46867800	Dummy Head (a-Mecha.)
	07997400	Erase Head (b-Mecha.)
23	47406100	Spring, azimuth
24	46268900	Pan Head Deltite Screw, M2.6 x 6
25	47282900	Flywheel Ass'y
26	47281200	Capstan Gear
27	47405200	Belt
28	47283100	Pully
29	46737600	Capstan Motor

Parts No.	Stock No.	Description
30	47281600	Lock Arm
31	46737500	Reel Motor
32	47293100	Gear, reel motor
33	47293800	Arm (B)
34	47283800	Assist Gear
35	47292600	Plunger Solenoid
36	—	Sub Chassis
37	47404600	Washer, d = 2.5
38	47530000	Spring A, Flywheel

7. OTHER PARTS

7-1. Front View

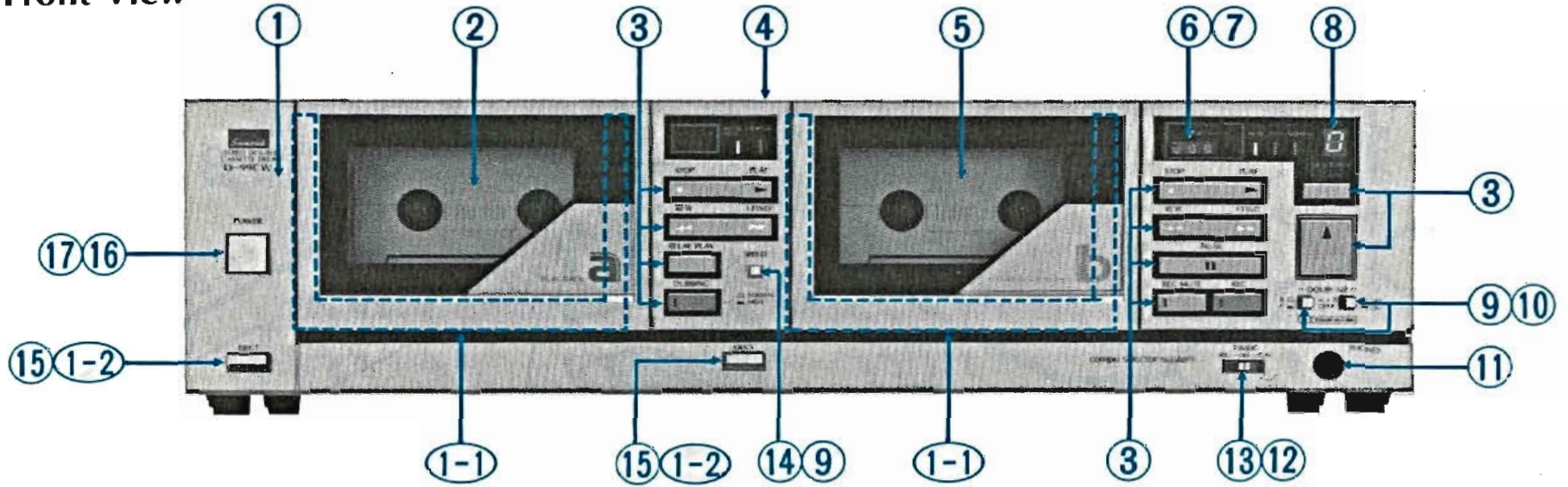

7-2. Top View

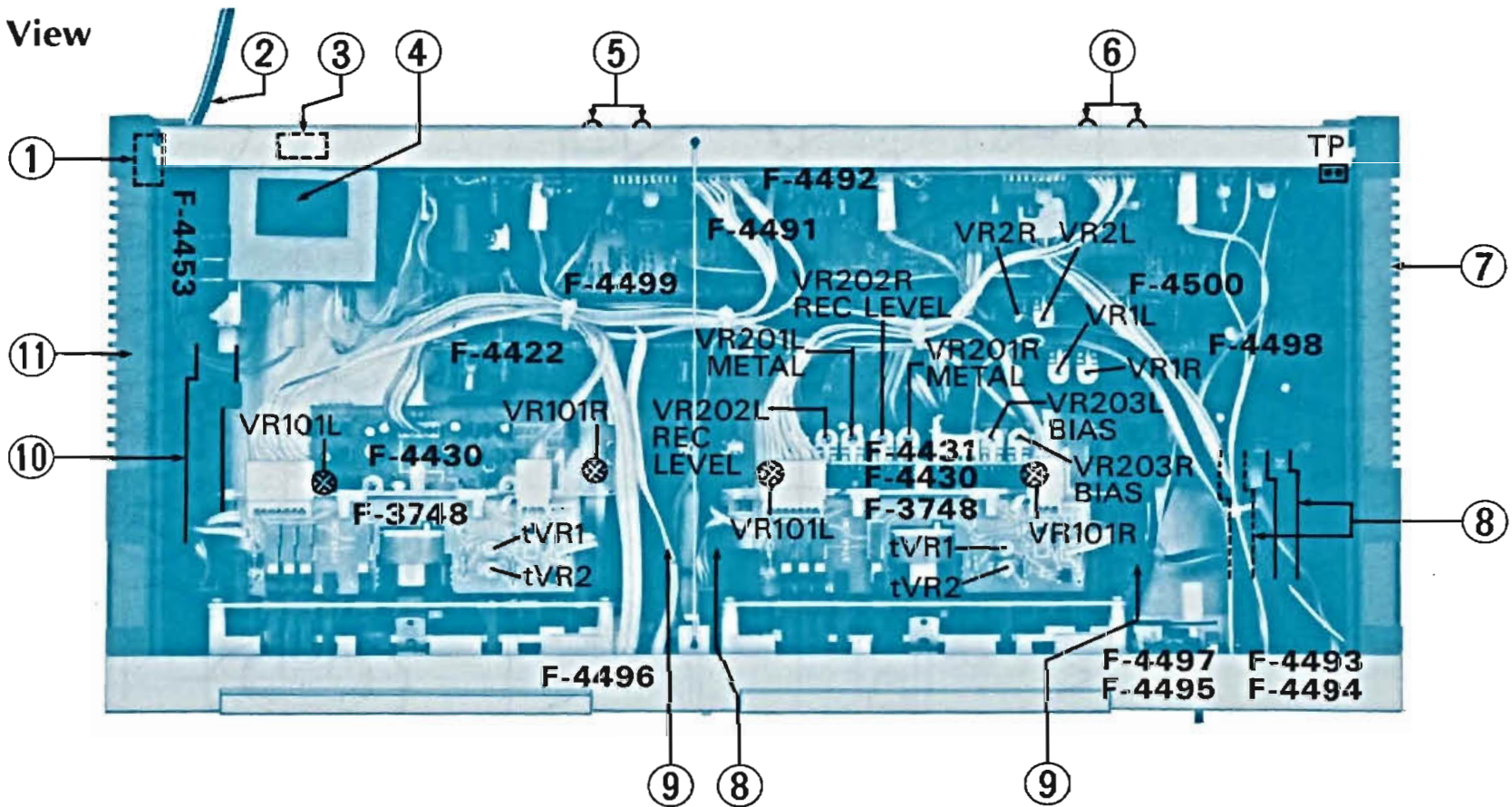

Parts List <Front View>

Parts No.	Stock No.	Description
1	47503700	Front Panel Ass'y (Silver Model)
	47503800	Front Panel Ass'y (Black Model)
1-1	47378300	Cassette Well Ass'y
1-2	47366800	Knob, EJECT (Silver Model)
	47366700	Knob, EJECT (Black Model)
2	47416400	Lid Ass'y a (Silver Model)
	47416500	Lid Ass'y a (Black Model)
3	46549500	Push SW., STOP, PLAY, REW, FF, PAUSE, DUBBING, REC MUTE, REC, AMPS, COMPU EDIT.
4	07966900	Bonnet
5	47416600	Lid Ass'y b (Silver Model)
	47416700	Lid Ass'y b (Black Model)
6	46920200	Tape Counter
7	47466400	Counter Belt
8	46917700	Indicator, AMPS
9	47005600	Knob, DOLBY NR, SPEED (Silver Model)
	07917300	Knob, DOLBY NR, SPEED (Black Model)
10	46430600	Push SW., DOLBY NR
11	46265700	Jack, PHONES
12	47189400	Knob, TIMER (Silver Model)
	47436700	Knob, TIMER (Black Model)
13	46178400	Slide SW., TIMER
14	46365300	Push SW., SPEED
15	47504300	Spring, EJECT

Parts No.	Stock No.	Description
16	07971220	Knob, POWER (Silver Model)
	07911210	Knob, POWER (Black Model)
△ 17	46360300	Push SW., POWER

Parts List <Top View>

Parts No.	Stock No.	Description
1	07917700	Power Supply Cord Cover
△ 2	38005400	Power Supply Cord (XX, CSA)
△	38004700	Power Supply Cord (UL)
△	38004500	Power Supply Cord (EU)
△	38004300	Power Supply Cord (BS)
△ 3	07204700	Slide SW., Voltage Selector (EU, BS)
△ 4	15016101	Power Transformer (XX)
△	15016102	Power Transformer (UL, CSA)
△	15016105	Power Transformer (EU, BS)
5	46547200	Jack, COMPU SELECTOR, COMPU EDIT
6	46371500	4P REC/PLAY Terminal Board
7	07952700	Side Panel Ass'y (Right)
8	47374900	Joint Shaft, DOLBY NR SW., SPEED SW.
9	46370300	Eject Damper Ass'y
10	07920700	Joint Shaft, POWER SW.
11	07952600	Side Panel Ass'y (Left)

8. SCHEMATIC DIAGRAM 8-1. Amplifier Section

*Design and specifications subject to change without notice for improvement.
 *La présentation et les spécifications sont susceptibles d'être modifiées sans préavis par suites d'améliorations éventuelles.
 *Änderungen, die dem technischen Fortschritt dienen, bleiben vorbehalten.

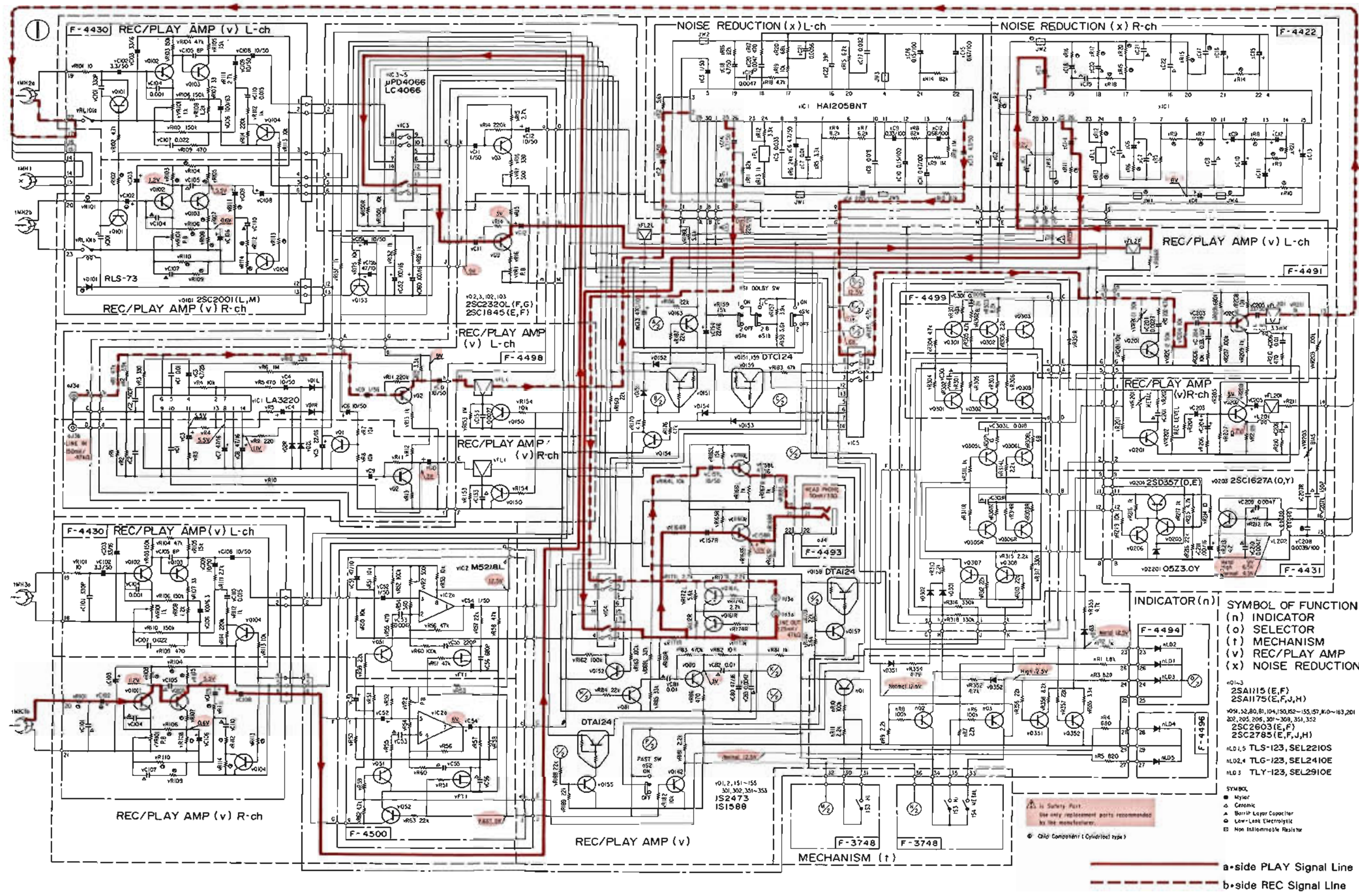

- 25A957
- 25A1115
- 25C1845
- 25C2001
- 25C2320L
- 25D438
- 25D357
- 25A1175
- 25C2786
- DTA124
- DTC124
- 25J103-BL
- 25J103-GR
- 25J103-Y
- BA6200
- M5218L
- 25D313AL
- μPD4066BC
- μPD4066BC
- LA3220
- LC4066BH
- MSM4069RS
- TC4069URC
- HA1205BNT
- TC9138AP
- TC9305P-004
- TC9310N-044
- TLG-123A
- TLG-123
- TLY-123
- SEL2210S
- SEL2410S
- SEL2910E
- IS1588PT-3
- IS247377
- 0625-8Y

1
2
3
4
5

8-2. Control Section

*Design and specifications subject to change without notice for improvement.
 *La présentation et les spécifications sont susceptibles d'être modifiées sans préavis par suites d'améliorations éventuelles.
 *Änderungen, die dem technischen Fortschritt dienen, bleiben vorbehalten.

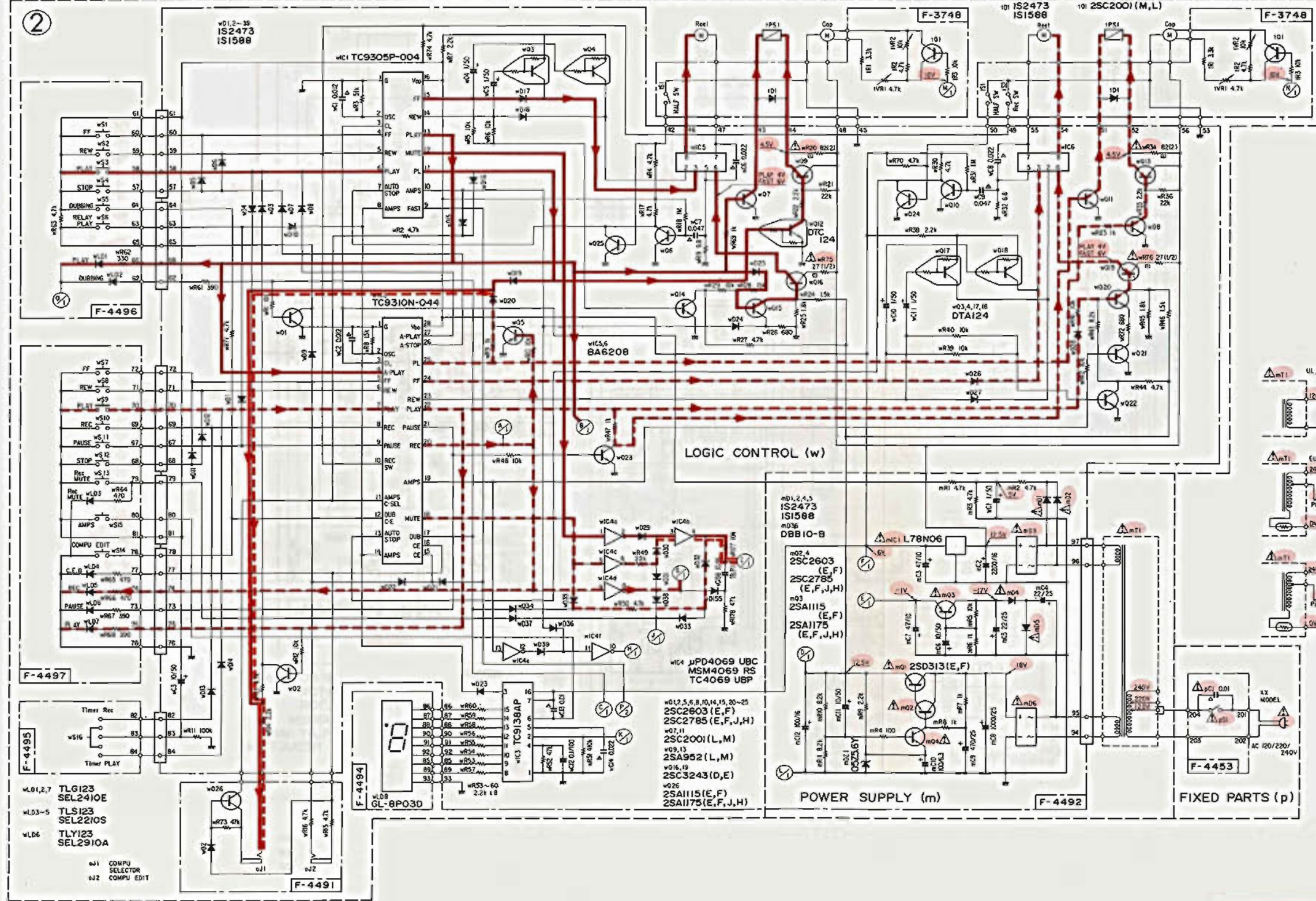

SYMBOL OF FUNCTION
 (m) POWER SUPPLY
 (o) SELECTOR
 (p) FIXED PARTS
 (t) MECHANISM
 (v) REC/PLAY AMP
 (w) LOGIC CONTROL

SYMBOL
 Δ Ceramic
 ▽ Barrier Layer Capacitor
 □ Non-Inflammable Resistor

RESISTORS
 Are in ohms, 1/4 Watts, ± 5% Tolerance
 Unless Otherwise Noted: K, M, MΩ

CAPACITORS
 Are in μF, Unless Otherwise Noted: P, pF

Electrolytic Capacitor: Capacitance (μF/Volts)

Each D.C. Voltage shows the nominal value in volts at during recording

⚠ is Safety Part.
 Use only replacement parts recommended by the manufacturer.

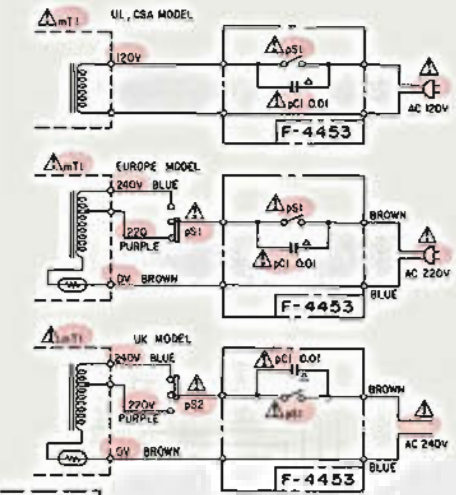

— a-side PLAY Line
 - - - b-side RECLine

9. INTERIOR BLOCK DIAGRAM OF IC

•LA3220 (ALC & PB. EQ Amp. IC)

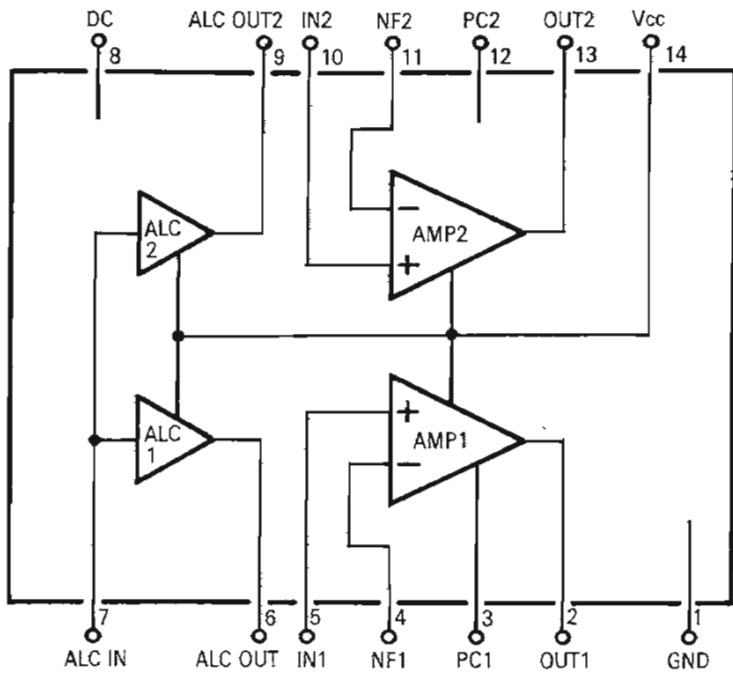

•LC4066H/ μ PD4066BC (Quad Analog SW. IC)

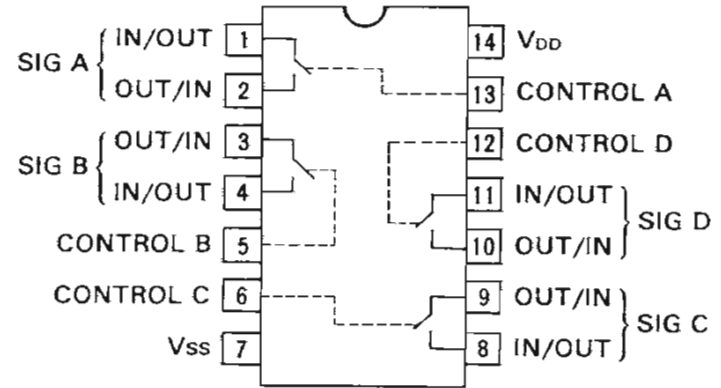

•MSM4069RS/TC4069UBC/ μ PD4069UBC (Hexad Inverter IC)

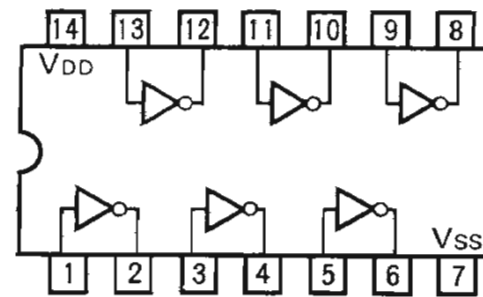

•HA12058NT (B & C-type DOLBY Noise Reduction IC)

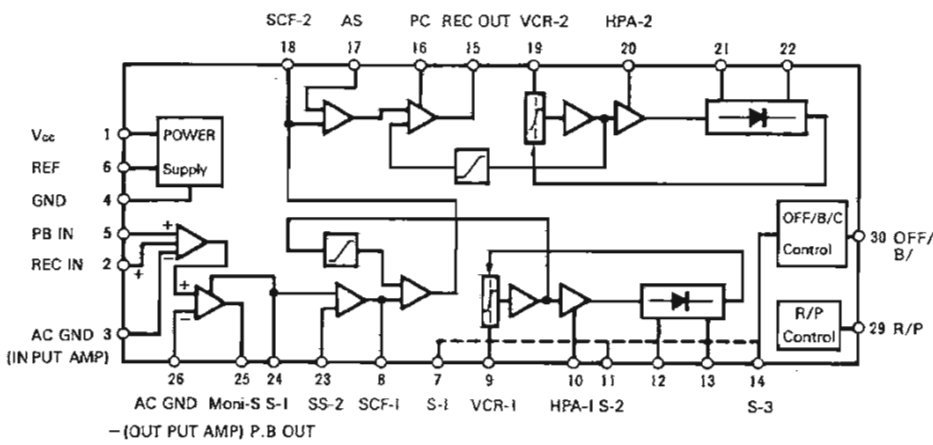

•M5218L (OP. Amp. IC)

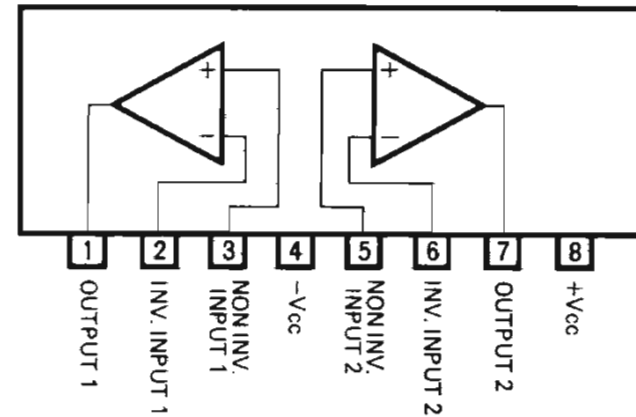

•TC9138P (AMPS IC)

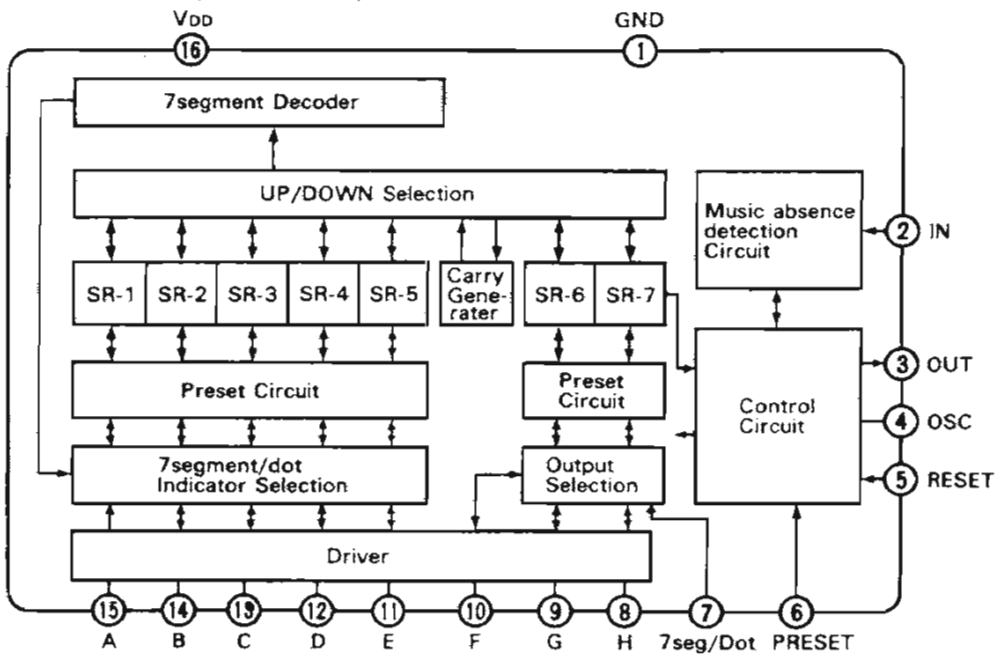

•BA6208 (Motor Drive IC)

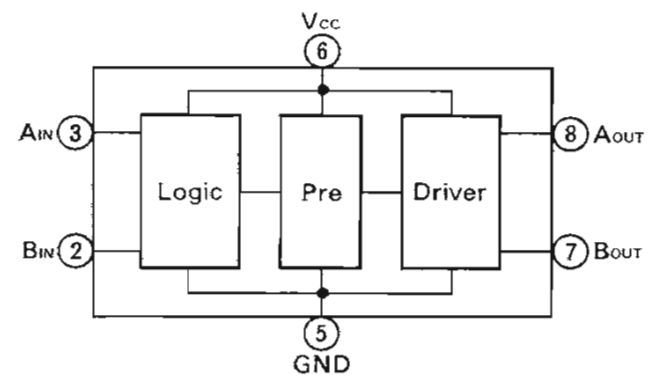

10. MAIN PARTS REPLACEMENT (See Exploded View on page 11 & 12)

A. Bonnet (See Fig. 10-1)

- 1) Remove two screws (SA).
- 2) Pull the rear side of the bonnet to remove the hooks and then remove it.

Fig. 10-1

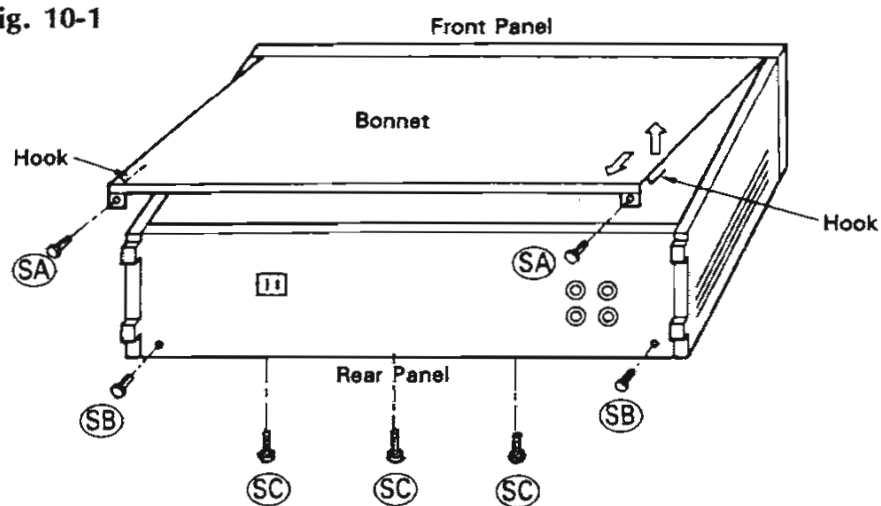

D. Side Panel L (or R) (See Fig. 10-4).

- 1) Remove the bonnet and the bottom plate.
- 2) Shift the position of the side panel L (or R) 2.0 cm into the arrow direction (1).
- 3) Undo the hooks (2) of the side panel and then pull it to the arrow direction (3) to remove it.

Fig. 10-4

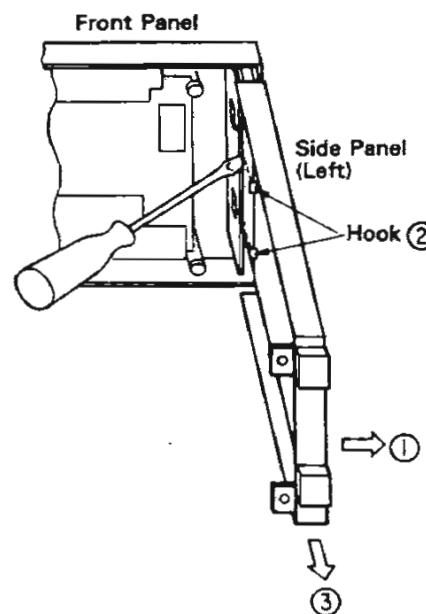

B. Bottom Plate (See Fig. 10-1 and 10-2)

- 1) Remove five screws (SB, SC).
- 2) Push the rear side of the bottom plate to undo the hooks and then remove it.

Note: Install the bottom plate after matching eject spring with point (A) of bottom plate.

Fig. 10-2

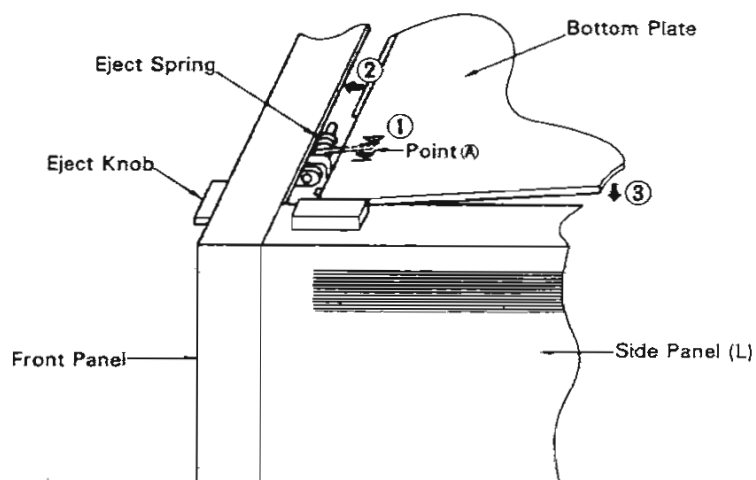

E. a-Mechanism Ass'y

- 1) Remove the bonnet, the bottom plate and tension wire.
- 2) Remove the side panel L.
- 3) Pluck out two connectors from F-3748 board.
- 4) Extract one connector from the F-4430 circuit board.
- 5) Loosen four screws fixing the mechanism ass'y.
- 6) Draw out the mechanism ass'y.

F. b-Mechanism Ass'y

- 1) Remove the bonnet, the bottom plate and tension wire.
- 2) Remove the side panel R.
- 3) Pluck out two connectors from F-3748 board.
- 4) Unhook two stopper lid of sockets on the F-4431 circuit board and then pull out two parallel cables.
- 5) Extract two connectors from the F-4430 circuit board.
- 6) Loosen four screws fixing the mechanism ass'y.
- 7) Take off counter belt.
- 8) Pull out the rear panel from hollows of side panel L.
- 9) Draw out the mechanism ass'y.

C. F-4430 and F-4431 Circuit Board

- 1) Remove the bonnet and the bottom plate.
- 2) Pluck out two connectors from F-4430 Circuit board.
- 3) Unhook two stopper lid of sockets on the F-4431 Circuit board and then pull out two parallel cables.
- 4) Remove the protection cover on the F-4430 circuit board.
- 5) Unsolder heads read wires.
- 6) Loosen two screws fixing F-4430 circuit board and then undo two hooks near S.V.R. on the F-4431 circuit board.

Fig. 10-3

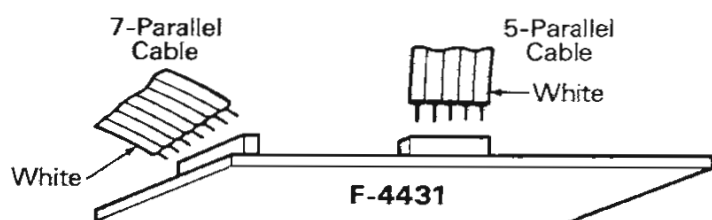

G. Rec/PB Head (21)

- 1) Remove the mechanism ass'y from set.
- 2) Unsolder head read wires.
- 3) Loosen two screws.

H. Pinch roller Ass'y (4)

- 1) Remove the mechanism ass'y from set.
- 2) Pull out the Plastic Tack (3).
- 3) Take out the pinchroller ass'y.

I. Reel Gear (17)

- 1) Remove the mechanism ass'y from set.
- 2) Take off two washer (19), (19) to pull out reel gear.

J. Capstan Motor ⑳, Reel Motor ㉑, Capstan Belt ㉒, Flywheel ㉓, Plunger Solenoid ㉔

- 1) Remove the F-4430 and F-4431 circuit board.
- 2) Remove the mechanism ass'y from set.
- 3) Loosen five screws ㉕, ㉖ fastening sub chassis ㉗.

K. Lid Ass'y

Depress the EJECT knob to open the cassette holder, and pull the lid ass'y up and then toward you to remove it as shown in the figure.

Fig. 10-5

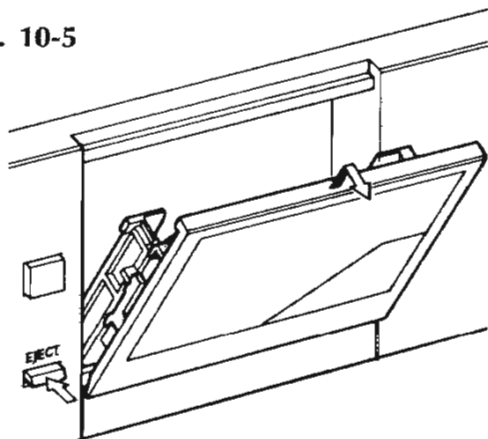

11. PACKING LIST

Parts No.	Stock No.	Description
1	—	Sub Packing & Carrgated Board
2	91263810	Polyethylene Bag
3	07949000	Styrofoam Packing
4	47505300	Carton Case (Silver Model)
	47505200	Carton Case (Black Model)

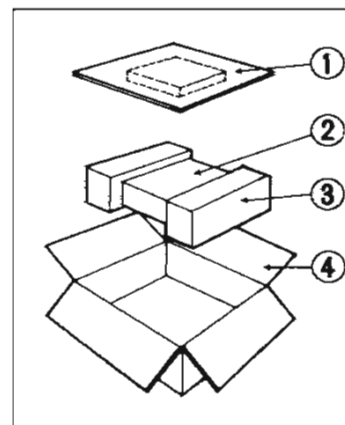

12. ACCESSORY LIST

Stock No.	Description
38103300	Pin Plug Cord
46267300	Mini Pin Plug Cord
94300500	Head Cleaner
46896800	Operating Instruction

D-99CW



SANSUI ELECTRIC CO., LTD.:

SANSUI ELECTRONICS CORPORATION:

SANSUI ELECTRONICS (U.K.) LTD.:

SANSUI ELECTRONICS G.M.B.H.:

14-1, Izumi 2-chome, Suginami-ku, Tokyo 168 Japan

PHONE: (03) 324-8891/TELEX: 232-2076 (International Division)

1250 Valley Brook Ave. Lyndhurst, N.J. 07071 U.S.A.

17150 South Margay Ave. Carson, California 90746 U.S.A.

3036 Koapaka Street. Honolulu, Hawaii 96819 U.S.A.

Unit 10A, Lyon Industrial Estate, Rockware Avenue, Geenford, Middx UB6, OAA, England

Pau Ehrich Strasse 8, 6074 Rödermark 2, West Germany

(SM1-144)

Printed in Japan (245220M) <Stock No. 36492700>