

OPERATING INSTRUCTIONS & SERVICE MANUAL

ELECTRONIC CROSSOVER AMPLIFIER/FOUR CHANNEL POWER AMPLIFIER

SANSUI ECA-3

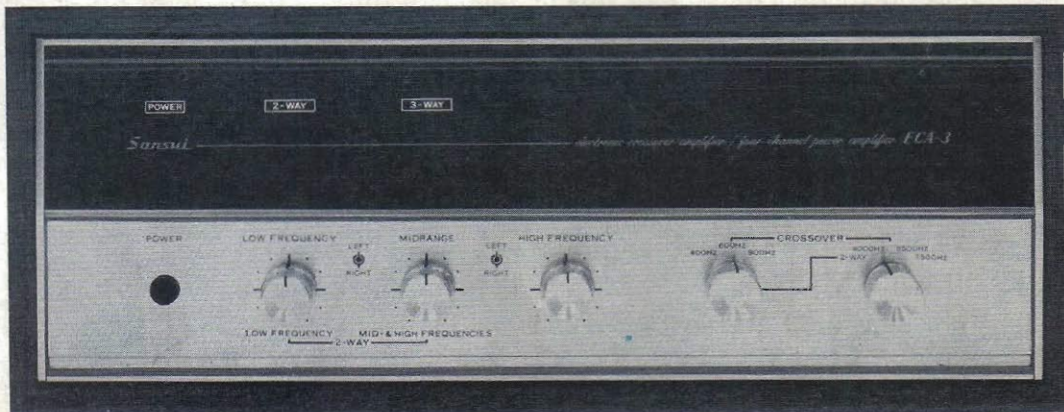

Sansui

SANSUI ELECTRIC COMPANY LIMITED

Congratulations on joining the thousands of proud, satisfied owners of quality stereo components from Sansui.

The ECA-3 integrated three-way electronic crossover and four-channel stereo amplifier is designed for use with a stereo pair of speaker systems to accomplish the two- or three- way electronic crossover system which has been widely acknowledged as the most effective method of reproducing original sounds and for use with two stereo pairs of speaker systems to achieve the exciting four-channel stereo arrangement without need of any other power amplifier. Crossover between low and mid ranges can be switch-selected to 400, 600 or 900Hz. Crossover between mid and high ranges can be selected to 4000, 5500 or 7500Hz. Cutoff can be also switch-selected to 12 or 6 dB/octave slope at both low and high crossovers.

This manual has been prepared to help you keep the ECA-3 in perfect operating conditions. It explains all of the ECA-3's unique features, connecting and operating procedures as well as some basic maintenance requirements.

Please read the contents of this manual carefully before operating the ECA-3. You will then be better prepared to enjoy the entirely new stereo sound to the fullest.

CONTENTS

SWITCHES AND CONTROLS	3, 4
OPERATIONS	5, 6
—ELECTRONIC CROSSOVER SYSTEM	
—TWO-WAY ELECTRONIC CROSSOVER SYSTEM	
OPERATIONS	7, 8
—THREE-WAY ELECTRONIC CROSSOVER SYSTEM	
OPERATIONS	9, 10
—FOUR-CHANNEL STEREO	
HINTS ON USE	11, 12, 13, 14
SPECIFICATIONS/CHARACTERISTICS/ACCESSORIES	
.....	15, 16
TROUBLESHOOTING CHART	17, 18
SCHEMATIC DIAGRAM	19, 20
ALIGNMENT.....	21, 22
BLOCK DIAGRAM	23
DISASSEMBLY PROCEDURE.....	24
CUSTOM MOUNTING	25, 26
PRINTED CIRCUIT BOARDS AND PARTS LIST	
.....	27, 28, 29, 30, 31, 32, 33, 34, 35, 36
OTHER PARTS AND THEIR POSITION ON CHASSIS	37, 38



POWER 2-WAY 3-WAY
Sansui electronic crossover amplifier / four channel power amplifier FCA-3

POWER LOW FREQUENCY MIDRANGE HIGH FREQUENCY Crossover
400HZ 800HZ 800HZ 1600HZ
2-WAY 2-WAY 2-WAY 2-WAY
LOW FREQUENCY MID- & HIGH FREQUENCIES

SWITCHES AND CONTROLS

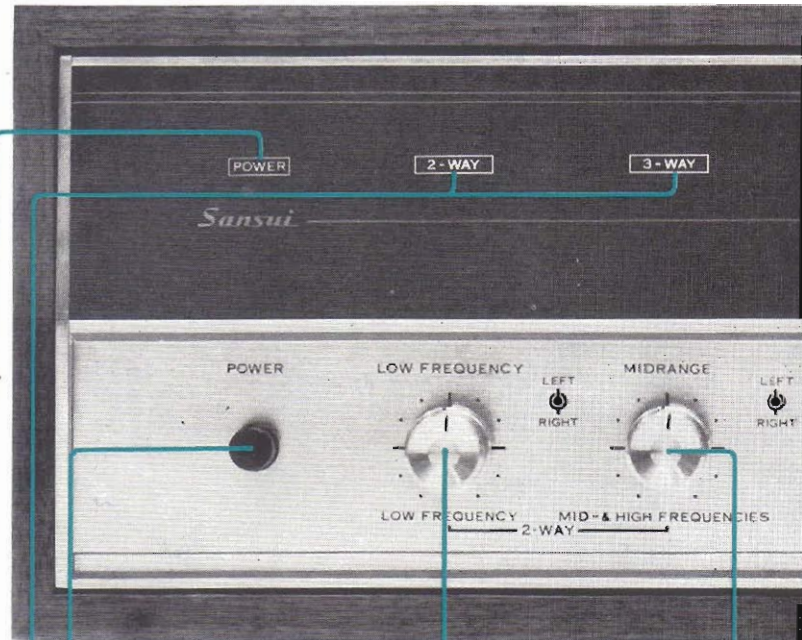

Power Indicator

This indicator glows when the Power switch is pushed on. It remains lit while the amplifier is on.

2 & 3 Way Indicators

The 2-WAY indicator glows when the right Crossover selector is set to the 2-WAY position and the 3-WAY indicator is illuminated when it is turned to any other position.

Power Switch

Power is applied to the amplifier when the Power switch is pushed. To turn off, push the Power switch again. The rear AC outlet marked SWITCHED is controlled by this switch.

Low-Frequency Level Control

This control is used to adjust the output level of low-frequency signals fed into the ECA-3 or the other stereo amplifier to which woofers are connected. To increase, turn it clockwise. To decrease, turn it counterclockwise.

Designed as a friction-coupled, dualconcentric control, it is actually two controls in one. The outer ring controls the strength of signals in the right channel; the inner knob controls the strength of signals in the left channel. Both outer and inner controls can be used simultaneously or independently, as required.

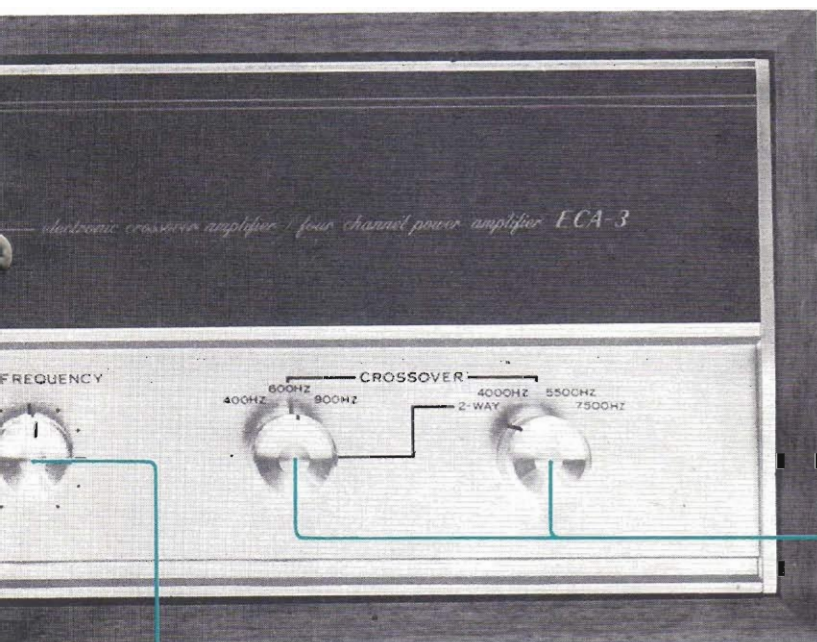

High-Frequency Level Control

In the three-way electronic crossover system, this control is used to adjust the output level of high-frequency signals fed into the ECA-3 or the other stereo amplifier to which tweeters are connected. Note that this control does not operate in case of two-way electronic crossover system.

Midrange Level Control

(Mid & High Frequency Level Control)

In the two-way electronic crossover system, this control allows adjustment of the output level of both mid and high frequency incoming signals fed into the ECA-3.

In the three-way electronic crossover system, this control determines only the midrange level of signals fed into the ECA-3 or the other stereo amplifier to which midranges are connected.

Crossover Selectors

In the three-way electronic crossover system, the left selector is used to select the crossover frequency between low and mid ranges 400, 600 or 900Hz; and the right selector is used to select the crossover between mid and high ranges 4000, 5500 or 7500Hz. In the two-way electronic crossover system, set the right selector to the **2 WAY** position and turn the left selector to the appropriate crossover.

OPERATIONS

ELECTRONIC CROSSOVER SYSTEM TWO-WAY ELECTRONIC CROSSOVER

Electronic Crossover System

The design goal of an 'ideal' speaker is to achieve flat response over the entire audio frequency range of 20 to 20,000Hz without distortion. A single speaker such as this is not yet to be developed. Instead, two or more speakers (woofer, midrange and tweeter) are used to cover this range. Each specializes in a certain frequency range, and the incoming audio signal is split up between them. Currently, there are two methods of channeling the signal; one is to use an L-C crossover network between the amplifier and speaker; the other is to use separate amplifiers to feed each driver within a speaker system, with the frequency separation accomplished electronically between the preamplifier and the power amplifier. The latter, called an electronic crossover system, has been acknowledged as the best hi-fi stereo system.

The ECA-3 allows simplified hookup of the electronic crossover system in combinations with the Sansui components as given in the chart below:

An Example of Connections for 3-Way Electronic Crossover System

	PRE-AMP.	LOW POWER AMP.	MIDRANGE POWER AMP.	HIGH POWER AMP.	SPEAKER SYSTEM		
2000A (2 way)	2000A	ECA-3 AMP-1	ECA-3 AMP-2		SP-2002	SP-2002	
2000A (3 way)	2000A	2000A	ECA-3 AMP-1	ECA-3 AMP-1	SP-2002	SP-2002	
3500	3500	3500	ECA-3 AMP-1	ECA-3 AMP-2	SP-2002	SP-2002	
TU-777	AU-999	AU-999	AU-999	ECA-3 AMP-1	ECA-3 AMP-2	SP-2002	SP-2002
TU-666	AU-666	AU-666	ECA-3 AMP-1	AU-666	ECA-3 AMP-2	SP-1001	SP-1001
TU-666	AU-555A	AU-555A	ECA-3 AMP-1	AU-555A	ECA-3 AMP-2	SP-1001	SP-1001

Two-way Electronic Crossover System

1. Connect the left channel output of an external preamplifier to the left channel INPUT jack on the rear panel of the ECA-3 and the right channel output of the preamplifier to the right channel INPUT jack.

Important: Carefully read the operating instructions for the preamplifier connected to the ECA-3. To obtain the best results, be sure to connect the outputs of the preamplifier to the inputs of the ECA-3.

2. Connect the left channel MIDRANGE CROSSOVER OUTPUT in the top row of jacks on the rear of the ECA-3 to the left channel POWER AMP-2 INPUT(L₂) in the lower row and the right channel MIDRANGE CROSSOVER OUTPUT to the right channel POWER AMP-2 INPUT(R₂).

3. Connect the left channel LOW FREQUENCY CROSSOVER OUTPUT to the left channel POWER AMP-1 INPUT(L₁) and the right channel LOW FREQUENCY CROSSOVER to the right channel POWER AMP-1 INPUT(R₁).

4. Connect the left channel midrange and tweeter to the left channel SPEAKERS terminals of the POWER AMP-2(L₂) and the right channel midrange and tweeter to the right channel SPEAKERS terminals of the POWER AMP-2(R₂).

5. Connect the left channel woofer to the left channel SPEAKERS terminals of the POWER AMP-1 (L₁) and the right channel woofer to the right channel SPEAKERS terminals of the POWER AMP-1 (R₁).

6. By using the Low Frequency level control, determine the amount of amplification of low range signals fed into the POWER AMP-1.

7. Adjust the Mid & High Frequency level control so that the same level as in the low range is achieved.



Designed especially for the electronic crossover system, the Sansui 2000A and 3500 stereo receivers are provided with the separate preamplifier section which can be used independently of the power amplifier section. Remove the PM connectors from the 2000A or the 3500, and connect its PRE OUT-PUT's to the inputs of the ECA-3.

— LEFT CHANNEL
— RIGHT CHANNEL

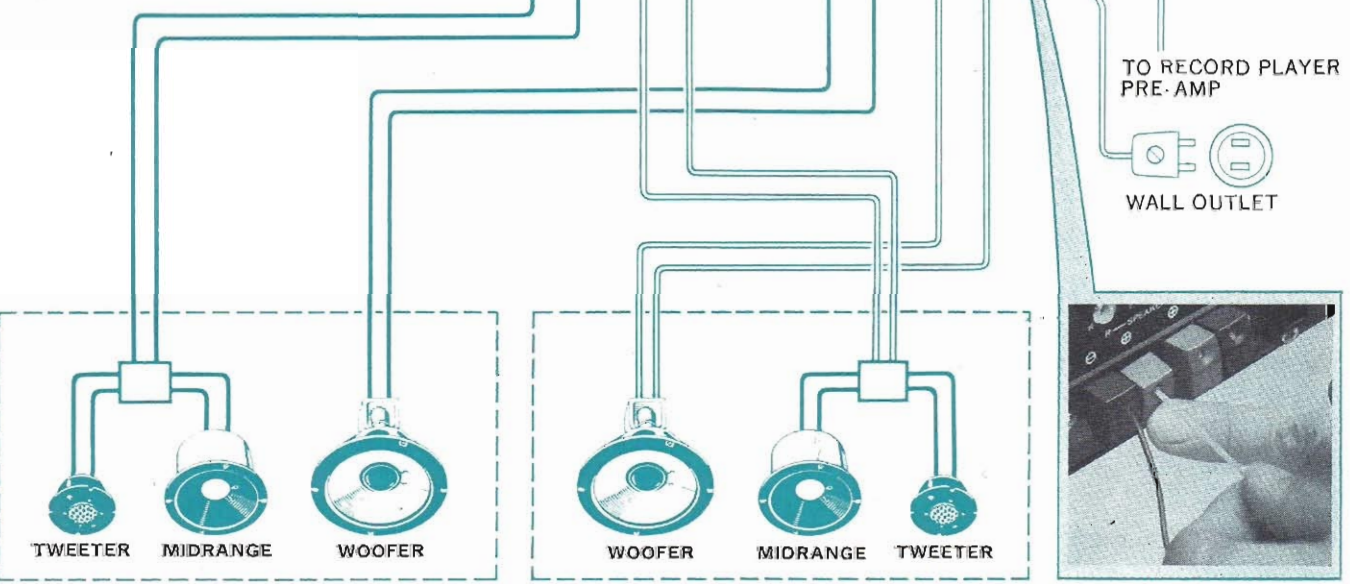
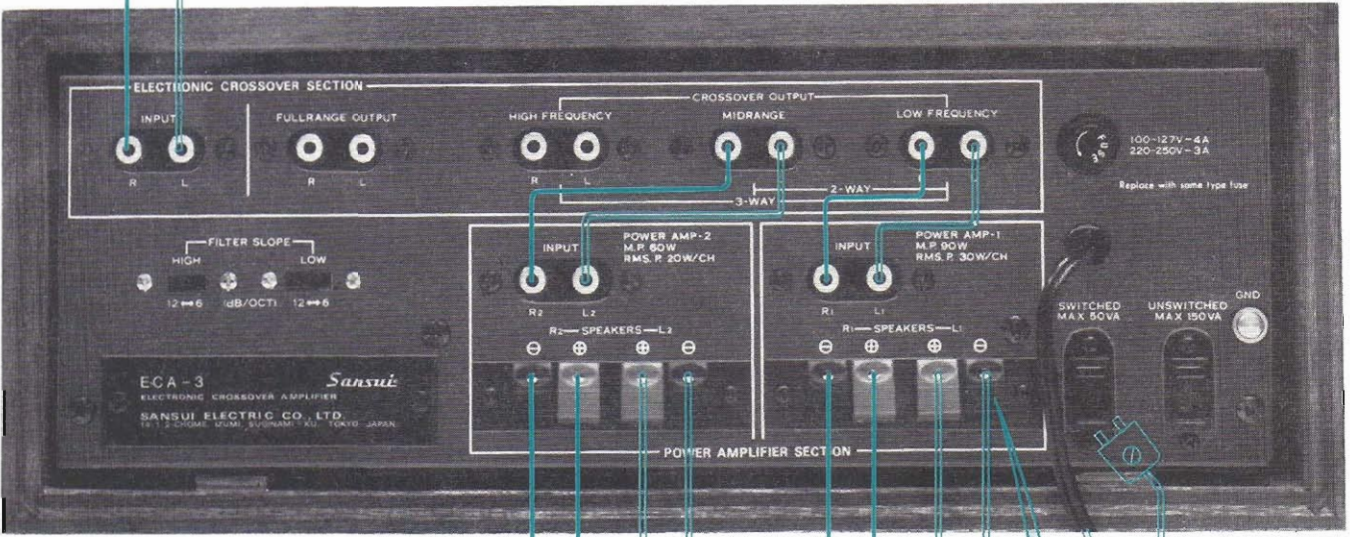

RIGHT SPEAKERS LEFT SPEAKERS CONNECTING TO SPEAKER TERMINALS

OPERATIONS

THREE-WAY ELECTRONIC CROSSOVER SYSTEM

Three-way Electronic Crossover System

To accomplish the three-way electronic crossover system, it is necessary to connect an additional stereo power amplifier to the ECA-3. As described in NOTES which follow this section, the power output of the additional amplifier determines which of the two other amplifiers should be used as a low-, mid- or high-range amplifier. If the additional amplifier has greater power than the Power Amp-1 of the ECA-3, below are the connecting procedures for the three-way electronic crossover system:

1. Connect the left channel output of an external preamplifier to the left channel INPUT jack on the rear panel of the ECA-3 and the right channel output of the preamplifier to the right channel INPUT jack.
2. Connect the left channel HIGH FREQUENCY CROSSOVER OUTPUT in the top row of jacks on the rear of the ECA-3 to the left channel POWER AMP-2 INPUT(L₂) in the lower row and the right channel HIGH FREQUENCY CROSSOVER OUTPUT to the right channel POWER AMP-2 INPUT (R₂).
3. Connect the left channel MIDRANGE CROSSOVER OUTPUT to the left channel POWER AMP-1 INPUT(L₁) and the right channel MIDRANGE CROSSOVER OUTPUT to the right channel POWER AMP-1 INPUT(R₁).
4. Connect the left channel LOW FREQUENCY CROSSOVER OUTPUT to the left channel input of an external power amplifier and the right channel LOW FREQUENCY CROSSOVER OUTPUT to the right channel input of the power amplifier.
5. Connect the left channel tweeter to the left channel SPEAKERS terminals of the POWER AMP-2(L₂) and the right channel tweeter to the right channel SPEAKERS terminals of the POWER AMP-2(R₂).
6. Connect the left channel midrange to the left channel SPEAKERS terminals of the POWER AMP-1(L₁) and the right channel midrange to the

right channel SPEAKERS terminals of the POWER AMP-1(R₁).

7. Connect the left channel woofer to the left channel output of the external power amplifier and the right channel woofer to the right channel output.
8. By using the Low Frequency level control on the front panel of the ECA-3, determine the amount of amplification of low range signals fed into the amplifier.
9. Adjust the Midrange level control so that the same level as in the low range is achieved.
10. Adjust the High Frequency level control so that the same level as in the low and mid ranges is achieved.

Notes:

- a. If the amplifiers used in the electronic crossover system differ from each other in power output, the woofers should be connected to the amplifier rated at the greatest watts, the midranges to one rated at the second greatest watts, and the tweeters to one rated at the smallest watts. Another consideration is that the low-range amplifier must give better performance characteristics at low frequencies and the high-range amplifier must give better performance characteristics at high frequencies.
- b. 'Phasing of Speakers' and 'Selection of Cutoff and Crossover' are given in the section entitled HINTS ON USE, p. 11.
- c. The crossover has the input impedance of 100k Ω . Use a preamplifier rated at lower output impedance (less than 10k Ω).
- d. Always use speakers of 4- to 16-ohm impedance.

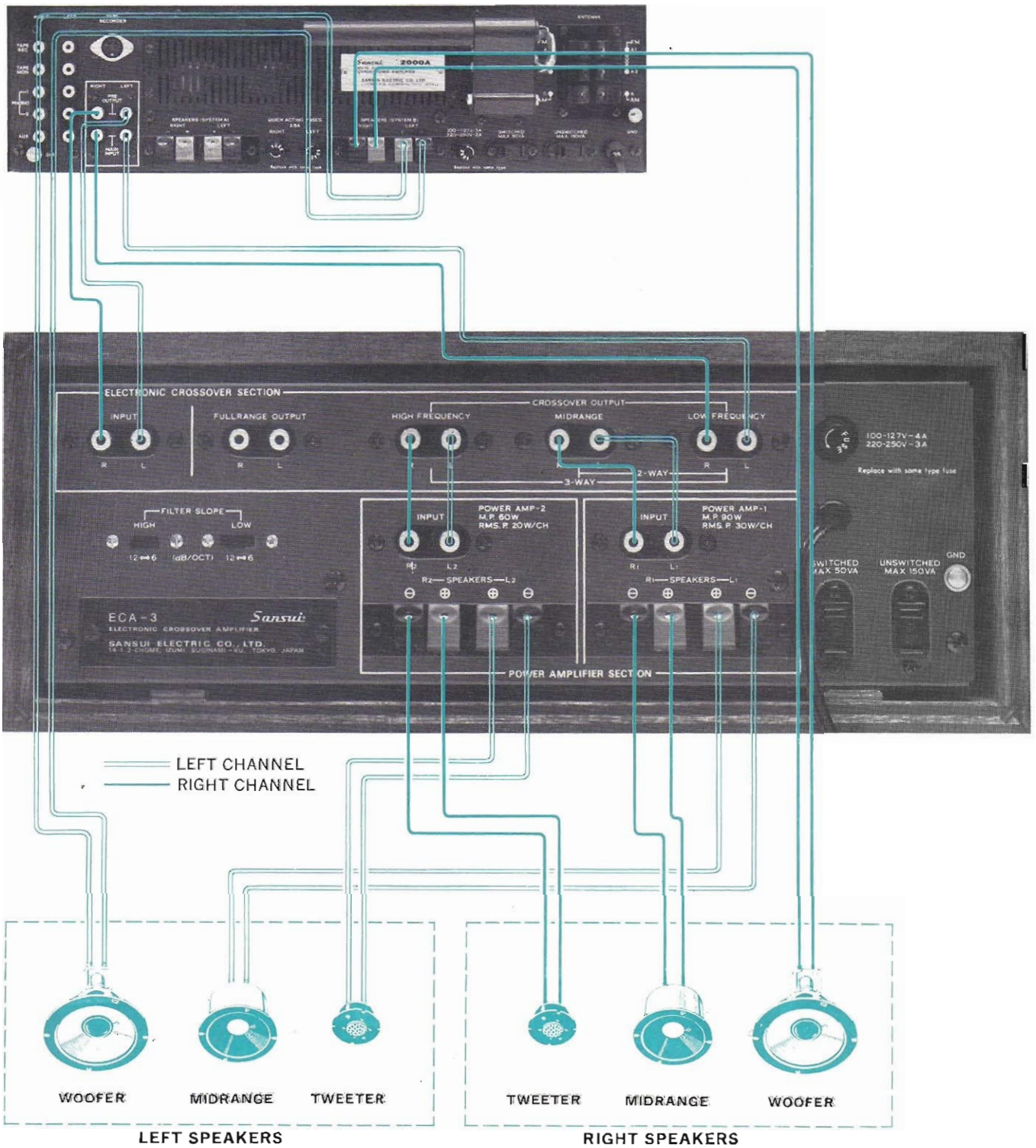

OPERATIONS

FOUR-CHANNEL STEREO

Four-channel Stereo

The four-channel or quadrasonic stereo system gives the most dramatic sound spread ever reproduced. Since the ECA-3 is provided with built-in four power amplifiers, it allows wiring up of two stereo pairs of speaker systems without need of any other power amplifier. To accomplish the four-channel stereo system, hook up additional components to the ECA-3 as illustrated on the opposite page:

1. Connect the front left-channel program source (of a quadrasonic tape, for instance) to the left-channel POWER AMP-1 INPUT(L₁) jack on the rear of the ECA-3 and the front right-channel program source to the right-channel POWER AMP-1 INPUT(R₁).
2. Connect the rear left-channel program source to the left-channel POWER AMP-2 INPUT(L₂) jack

on the rear of the ECA-3 and the rear right-channel program source to the right-channel POWER AMP-2 INPUT(L₂).

3. Connect the front left-channel speaker to the left-channel SPEAKERS terminals of the POWER AMP-1(L₁) and the front right-channel speaker to the right-channel SPEAKERS terminals of the POWER AMP-1(R₁).

4. Connect the rear left-channel speaker to the left-channel SPEAKERS terminals of the POWER AMP-2(L₂) and the rear right-channel speaker to the right-channel SPEAKERS terminals of the POWER AMP-2(R₂).

Note: In this case, all of controls of the ECA-3 are turned off. To adjust the volume, tone etc., use the controls of the preamplifiers connected to the ECA-3.

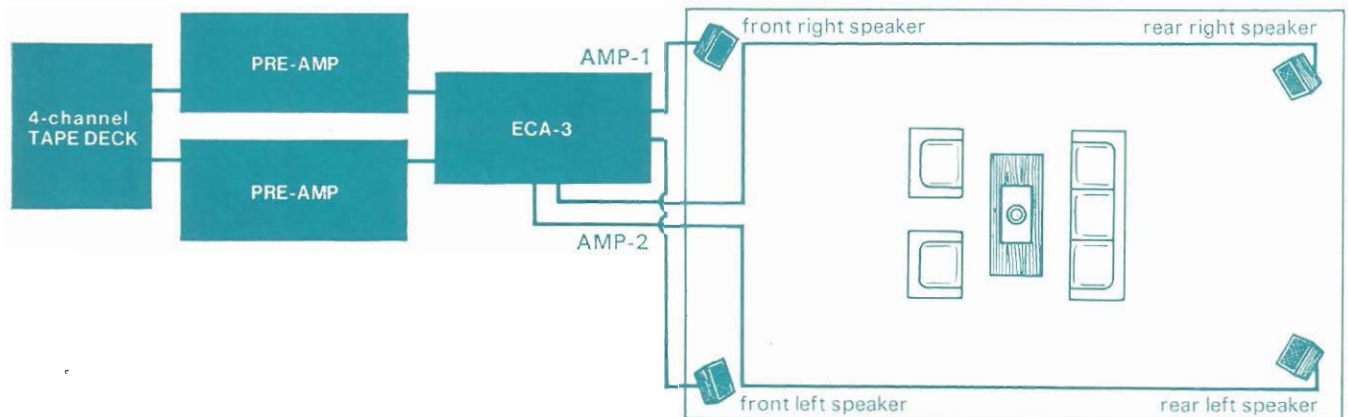

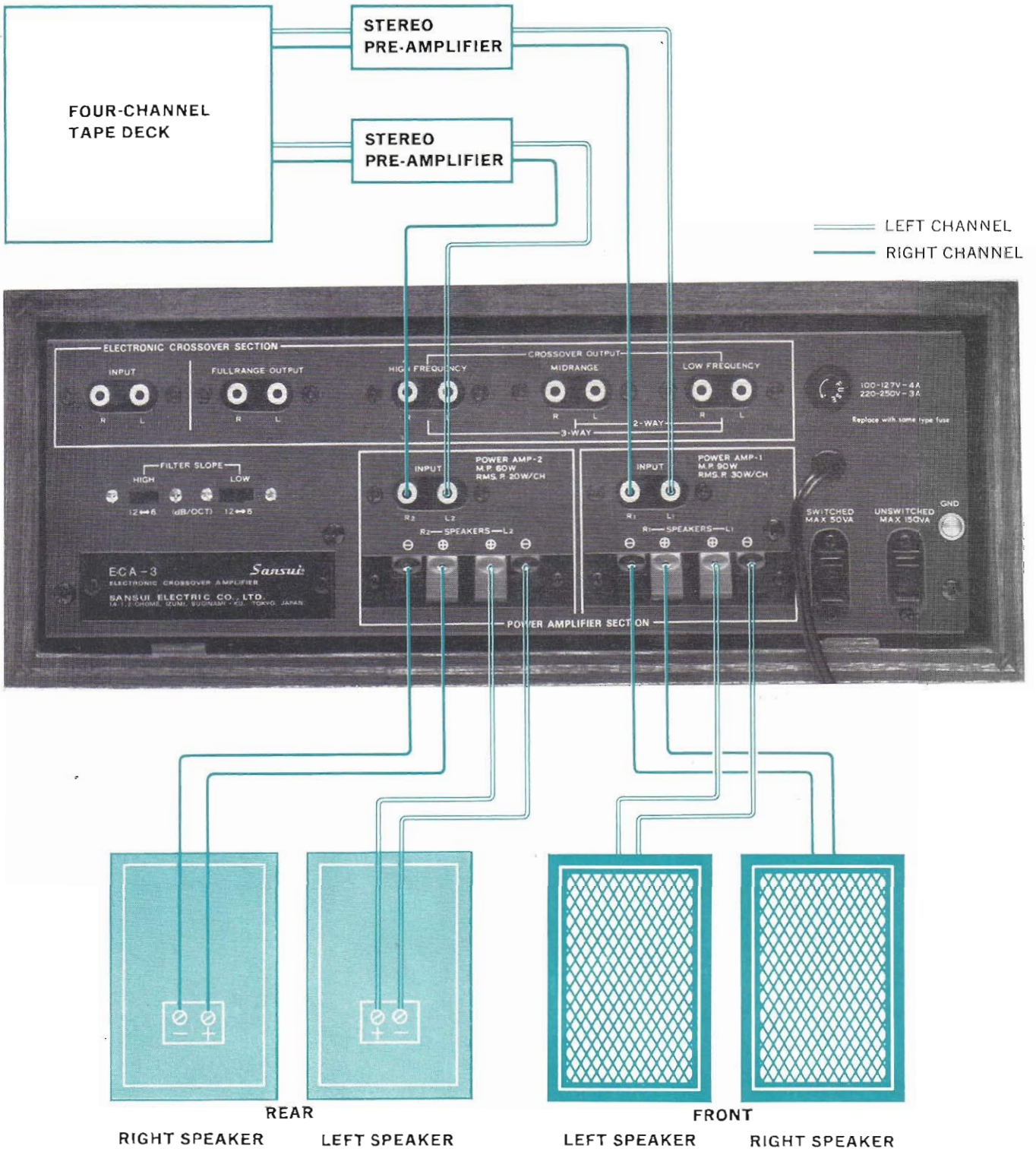

HINTS ON USE

Phasing of Speakers

The left and right speakers must be properly phased. They must push the sound waves out together. If one pushes while the other pulls, there is sound cancellation at some frequencies or in some listening locations. To correct this, reverse the leads to one speaker.

In the electronic crossover system, the speakers should be phased as given below:

In Case of 6 dB/octave Slope

Low-frequency output lags 45° , while midrange leads 45° ; and midrange lags 45° , while high-frequency output leads 45° . The phase difference between outputs is equal to 90° . Thus, the woofers, midranges and tweeters may be connected either in phase or in phase opposition (usually in phase is better). But the acoustics of your listening room and positioning of speakers will also dictate the phasing of speakers. The speakers, in any case, should be phased for natural sound.

In Case of 12dB/octave Slope

Low-frequency output lags 90° , while midrange leads 90° ; midrange lags 90° , while high-frequency output leads 90° . The phase difference between outputs is equal to 180° . Usually the midranges in a three-way system or the tweeters in a two-way system should be connected in phase opposition. But the acoustics of your listening room and positioning of speakers are important factors determining the speaker phasing. In conclusion, the speakers should be phased for natural sound.



Filter Slope Switches

The Filter Slope switch marked HIGH is used to select the cutoff between 6 and 12 dB/octave slopes at mid and high frequencies. The switch marked LOW is used to select the cutoff between 6 and 12 dB/octave slopes at low and mid-frequencies.

Selection of Proper Cutoff and Crossover

As a general rule, when the horn-type midranges and tweeters are used, the Filter Slope switch should be set to the 12 dB/octave position and the Crossover selector should be set to a position $1\frac{1}{2}$ or 2 times as large as their specified lower limit frequencies. This is because the horn-type speakers have relatively low sound pressure at the lower frequencies.

When cone-type speakers are used over entire range (for instance, in a two-way system in which a full-range speaker is used for lower range and a cone-type tweeter is used for higher range at crossover 2 times as large as the lower-limit frequency of the tweeter), the Filter Slope switches should be set to 6 dB/octave for better results. Since the 6 dB/octave slope is more gentle, care should be taken not to apply too big input to the horn-type speakers. This may cause damage to the system.

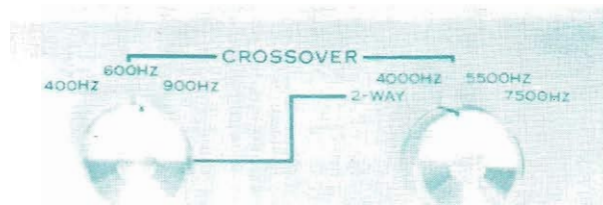

Fullrange Terminals

The Fullrange jacks are used for comparative listening tests between the electronic crossover system and the conventional L-C crossover network system, and for listening tests of additional components through the same program source without decomposing the built-up electronic crossover system. Undivided programs can be obtained from the Fullrange jacks.

The Fullrange jacks should be connected to the inputs of the additional power amplifier to which the fullrange speaker system is connected. The power amplifier required should have sufficiently high input impedance.

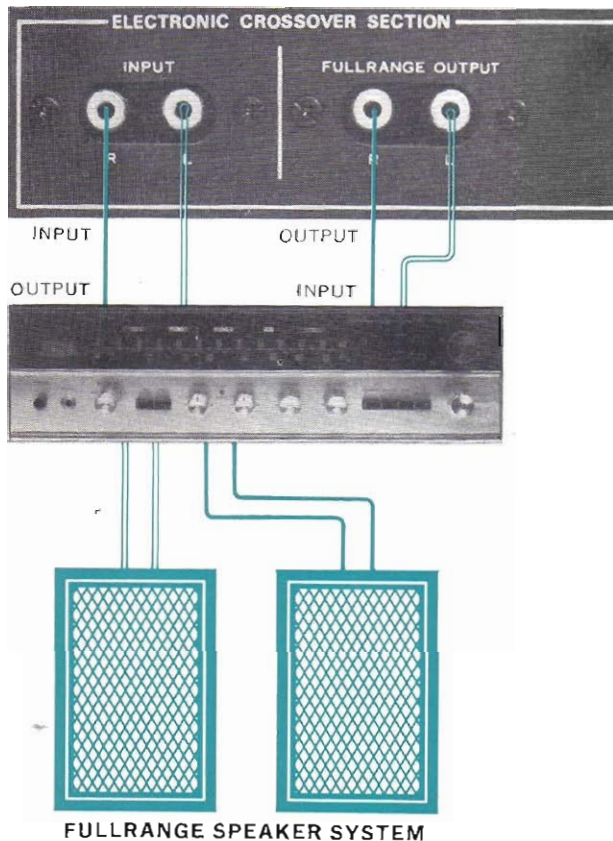

Wire Connections

Shielded wire should be used for component connections. If connections are loose or in touch with other parts, the amplifier will not function properly, may pick up noise, and even breakdown over a long period of time.

Important: Be sure to read the manufacturer's instructions for any component before connecting it to the ECA-3.

AC Outlets

The ECA-3 is provided with two AC outlets on its rear panel. The left outlet marked SWITCHED is switched on and off by the Power switch on the front panel.

Caution: The SWITCHED outlet has a maximum capacity of 50 VA and the UNSWITCHED outlet 150 VA. Never use them beyond their rated capacities.

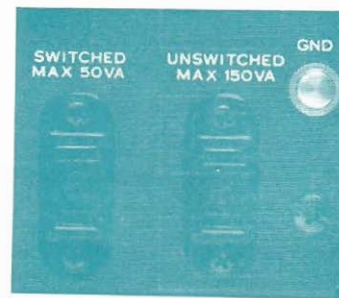

HINTS ON USE

Grounding

Connect one end of vinyl or enameled wire to the terminal screw marked GND on the rear of the amplifier, attach a copper plate to the other end and bury it underground. To prevent hum caused by interconnection of components, connect the body ground leads of the turntable, tape deck or other components to this terminal.

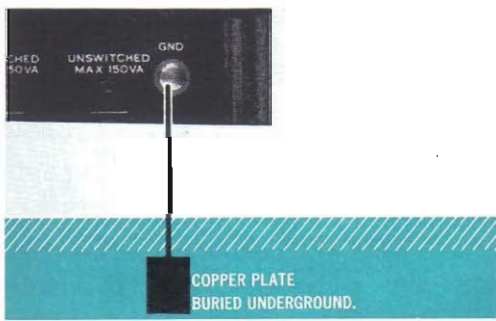

Power Fuse

If the unit remains completely dead when the power is switched on (Power indicator fails to light), the power fuse is probably blown. In this case, remove the power plug from its AC outlet and replace the fuse after finding and eliminating the trouble that caused the fuse to blow.

Caution: For the power supply voltage of 100 to 127 volts, use a glass-tubed 4-ampere fuse; for 220 to 250 volts, use a glass-tubed 3-ampere fuse. Never attempt to use a piece of wire or a fuse of a different capacity as a substitute.

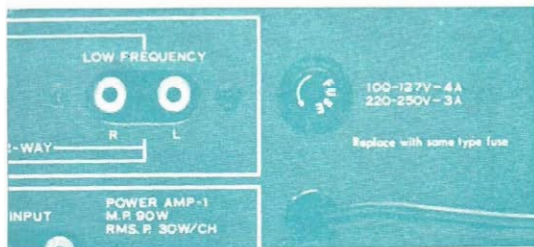

Quick-acting Fuses

The quick-acting fuses protect expensive power transistors of the built-in four power amplifiers. If one of the power transistors does not function when the Power switch is pushed on and the Power indicator is lit, its quick-acting fuse is probably blown. Immediately remove the power plug from its AC outlet, remove the wood case from the chassis, and check the fuse; and, if necessary, replace it. Be sure to use:

2.5-ampere fuses for Power Amp-1

2-ampere fuses for Power Amp-2

Before replacing, check for the source of trouble that caused the fuse to blow. If the new fuse blows as soon as the Power switch is pushed on, check for the defective power circuit. If the trouble source cannot be located, contact the nearest Sansui dealer or Service Center.

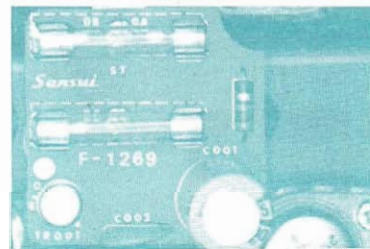
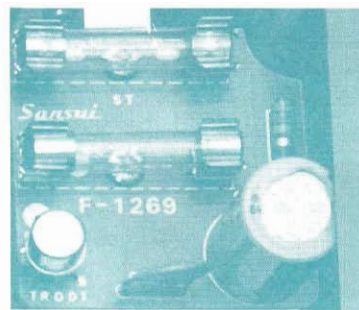

Voltage Adjustment

To reach the voltage selector, remove the two screws from the nameplate on the rear panel and then remove the nameplate. The voltage selector make it possible to operate the ECA-3 at the correct voltage in any area.

The voltage has been pre-adjusted at the factory, but can be easily readjusted as follows:

STEP I Set arrow of main voltage selector plug to required voltage: 100, 110, 117, 127, 220, 230, 240 or 250 volts.

STEP II If numerals of voltage are printed in red, set arrow of adjacent sub V.S. plug to position marked red. If they are printed in white, set arrow to position marked white.

STEP III The power fuse should also be changed whenever the AC line voltage is changed. For 100-127 volt operation a 4-ampere fuse is required. For 220-250 volt operation the fuse should be changed to a 3-ampere unit.

NOTE: The Voltage Adjustor can be used to eliminate the trouble caused by the considerable voltage fluctuation. In this case, it should be set to the peak voltage.

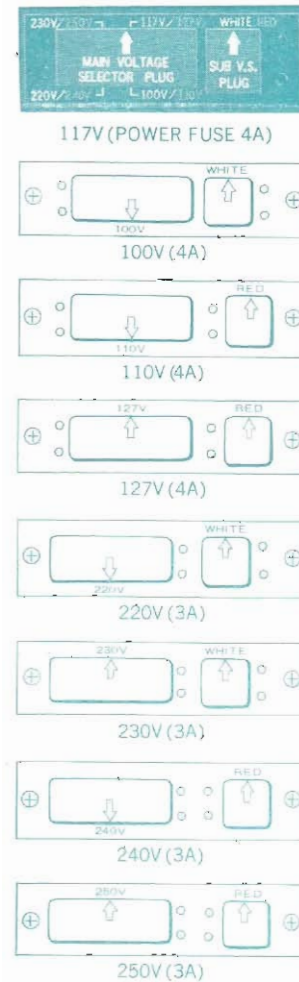

SPECIFICATIONS / CHARACTERISTICS

ACCESSORIES

NO. 1 POWER AMPLIFIER SECTION

POWER OUTPUT:

MUSIC POWER (IHF): 90W at 4 ohms load
70W at 8 ohms load

CONTINUOUS POWER: 35/35W at 4 ohms load
30/30W at 8 ohms load

TOTAL HARMONIC DISTORTION:
less than 0,3% at rated output

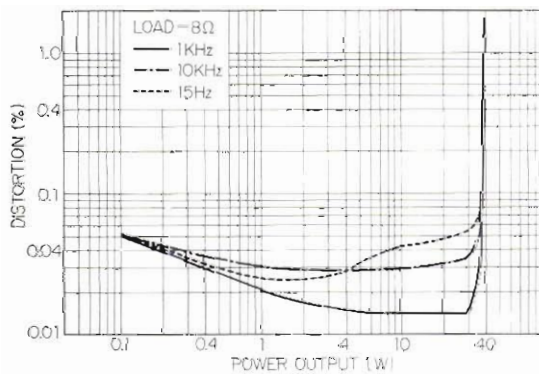

INTERMODULATION DISTORTION (60Hz: 7,000 Hz=4:1 SMPTE method)

less than 0.3% at rated output

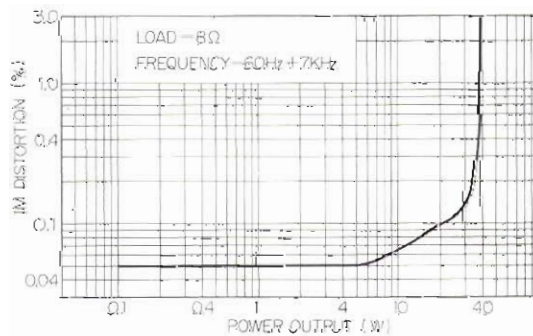

POWER BANDWIDTH (IHF): 15 to 40,000Hz

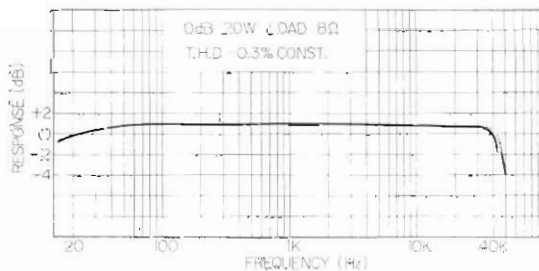

FREQUENCY RESPONSE (at normal listening level):

15 to 70,000Hz \pm 1dB

CHANNEL SEPARATION: better than 50dB

HUM AND NOISE (IHF): better than 80dB

INPUT SENSITIVITY: 0.5V for rated output

INPUT IMPEDANCE: more than 47k ohms

LOAD IMPEDANCE: 4 to 16 ohms

DAMPING FACTOR: 30 at 8 ohms load

NO. 2 POWER AMPLIFIER SECTION

POWER OUTPUT:

MUSIC POWER (IHF): 60W at 4 ohms load
50W at 8 ohms load

CONTINUOUS POWER: 25/25W at 4 ohms load
20/20W at 8 ohms load

TOTAL HARMONIC DISTORTION:
less than 0.3% at rated output

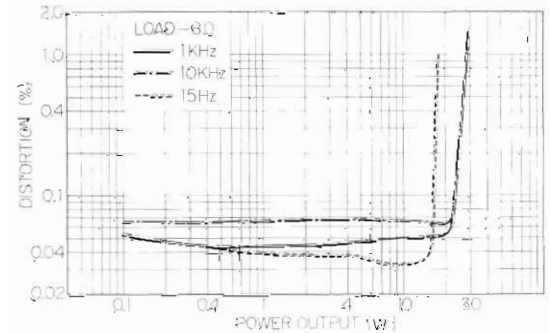

INTERMODULATION DISTORTION (60Hz: 7,000Hz =4:1 SMPTE method):

less than 0.3% at rated output

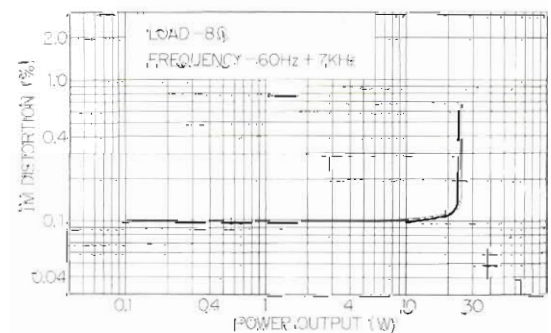

POWER BANDWIDTH (IHF): 30 to 40,000Hz

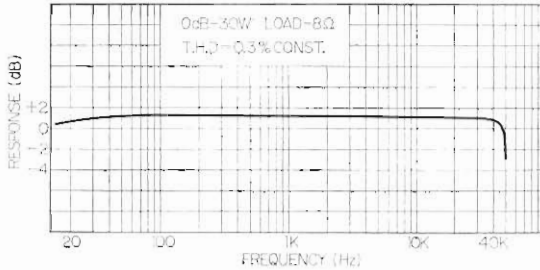

FREQUENCY RESPONSE (at normal listening level):
30 to 40,000Hz \pm 1dB

CHANNEL SEPARATION: better than 50dB at rated output

HUM AND NOISE (IHF): better than 80dB
 INPUT SENSITIVITY: 0.5V for rated output
 INPUT IMPEDANCE: more than 47k ohms
 LOAD IMPEDANCE: 4 to 16 ohms
 DAMPING FACTOR: 30 at 8 ohms load

ELECTRONIC CROSSOVER NETWORK SECTION

OUTPUT VOLTAGE:

MAXIMUM OUTPUT VOLTAGE: 3V
 RATED OUTPUT VOLTAGE: 0.5V

INPUT VOLTAGE:

MAXIMUM INPUT VOLTAGE: 3.5V
 RATED INPUT VOLTAGE: 0.55V for rated output Voltage

FILTER OUTPUT: LOW FREQUENCY, MIDRANGE, HIGH FREQUENCY

TOTAL HARMONIC DISTORTION: less than 0.3% at maximum output level

HUM AND NOISE (IHF): better than 90dB

CROSSOVER FREQUENCY SELECTOR:

400, 600, 900Hz (lower crossover of 2-way and 3-way Speaker System)
 2-way, 4,000, 5,500, 7,500Hz (upper crossover of 3-way Speaker System)

CROSSOVER FREQUENCY ERROR: less than 20%

CONSTANT LOSS: less than 3dB

CROSSOVER ATTENUATION: 3dB \pm 1dB

CUTOFF CHARACTERISTIC: 6dB/oct and 12dB/oct (upper and lower crossovers are switchable individually)

6 dB/oct

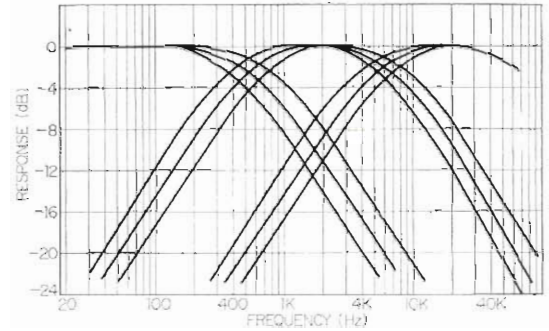

12 dB/oct

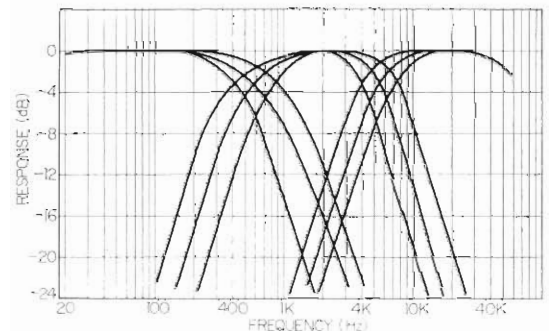

INPUT IMPEDANCE: 100k ohms
 LOAD IMPEDANCE: 10k ohms or more
 SEMICONDUCTORS: Transistors: 49 Diodes: 4
POWER REQUIREMENTS
 POWER VOLTAGE: 100, 110, 117, 127, 220, 230, 240, 250V 50/60Hz
 POWER CONSUMPTION: 350VA (max. signal)
 DIMENSIONS: 382mm (15 1/16")W, 162mm (6 3/8")H, 335mm (13 3/16")D
 WEIGHT: 12.2kg (26.9 lbs.)

* All rights reserve specifications subject to change without notice.

Accessories

1. OPERATING INSTRUCTIONS AND SERVICE MANUAL 1
2. OPERATING SHEET 1
3. CONNECTION CORDS WITH PIN-PLUGS 8
4. POLISHING CLOTH 1
5. QUICK ACTING FUSES (2A) 2
6. QUICK ACTING FUSES (2.5A) 2

TROUBLESHOOTING CHART

A Quick Check List

- 1) **Connections:** Are other components properly connected to the amplifier? Is the amplifier properly plugged into the wall AC outlet?
- 2) **Operation:** Are you operating the amplifier correctly as instructed in this booklet?
- 3) **Installation:** Is the amplifier properly position-

ed in relation to the speakers and phonograph?

4) **Defective components:** Are the audio components connected to the amplifier defective?

5) **Performance characteristic:** Are you not placing an excessive strain on the amplifier to raise some particular performance characteristic?

PROGRAM	SYMPTOM	PROBABLE CAUSE	REMEDY
Radio broadcast	Constant or intermittent noise heard at certain hours or in a certain area.	Electric discharge or oscillation by a fluorescent lamp, TV, series motor, electrical contact, rectifier, oscillator, etc. Insufficient antenna input due to long distance from broadcast stations or obstruction of signals by mountains or high ferroconcrete buildings. Interference by other radio waves. Natural phenomena such as an atmospheric discharge and lightning.	Attach a noise suppressor to the tuner or the electrical appliance producing the noise. Place the tuner away from the electrical appliance producing the noise. Install an outdoor antenna and ground the amplifier to improve its S/N ratio. If the noise occurs at a certain frequency, attach a wave trap to the antenna input circuit of the tuner. Reverse the inserted position of the power cord plug.
	Noise heard on AM band at certain hours, in a certain area or at particular broadcast frequencies.	Insufficient signal strength.	Install an outdoor AM antenna, or if it is already installed, reposition it for best reception. Ground the amplifier and/or reverse the inserted position of the power cord plug.
	High-frequency noise.	Interference by adjacent channel (beat interference). TV set near to the amplifier is in use.	While noise due to such causes cannot be eliminated by adjusting the amplifier, it can be made less disturbing by turning down the TREBLE tone control or turning on the HIGH filter switch on the preamplifier. Move the amplifier away from the TV set.
	FM broadcast reception is noisy.	Poor noise limiter effect and lowered S/N ratio due to insufficient antenna input, resulting either from poorly positioned FM antenna or long distance from stations.	Re-position the FM antenna for the least noise and best reception. If this proves ineffective, install an exclusive outdoor FM antenna and position it for the best reception.
	NOTE: Quality of FM broadcast reception is largely affected by the transmitting conditions (such as antenna efficiency) of broadcast stations. So you may receive one station quite well while having difficulty in receiving another.		TV antenna may be shared for FM broadcast reception, but be sure to use a divider and make certain the TV reception is not affected. Excessively long antenna may increase noise.
	A series of pops on FM band.	Ignition noise made by the starting of a nearby automobile engine.	No effective remedy except to move the antenna as far away from the street as possible or increase the antenna input as instructed above. Position the antenna so as to maximize the antenna input.

PROGRAM	SYMPTOM	PROBABLE CAUSE	REMEDY
Radio broadcast (cont'd)	Noise heard with FM MPX broadcasts that was not heard with FM monophonic broadcasts.	Unavoidable because of the nature of FM MPX signals which cut down effective service area to half that of FM monophonic signals.	Turning on HIGH FILTER Switch and/or turning down TREBLE tone control may considerably reduce the noise.
Record and tape	Hum or howling.	Phonograph is placed on top of or near one of the speakers. Use of wire other than shielded wire. Incomplete connection. Connection cord too close to power cord and/or electrical appliances such as a fluorescent lamp. Existence of an amateur radio station or TV transmitting antenna in the vicinity.	Place a cushion underneath the phonograph. Try changing the location of the phonograph and speakers Use regular shielded wire to make interconnections. Turning on LOW FILTER switch may help. Minimize the length of connection cord. Refrain from turning up BASS tone control too high. Consult your nearest governmental (or municipal) radio regulatory office.
	Surface noise.	Worn or damaged record, or dust on record Worn stylus, or dust on stylus. Improper stylus pressure.	Turning down TREBLE tone control or turning on HIGH FILTER switch may help. Recondition (or replace) the phonograph stylus or tape head.
All programs	BALANCE control is off the center position when sound volumes in the right and left channels are balanced.	Position of the BALANCE control which gives equal sound volume from both channels varies from program to program.	Set the preamplifier's MODE switch in MONO and adjust its BALANCE control for equal sound volume from both channels. Check if the efficiency of one speaker is balanced with that of the other.

SCHEMATIC DIAGRAM

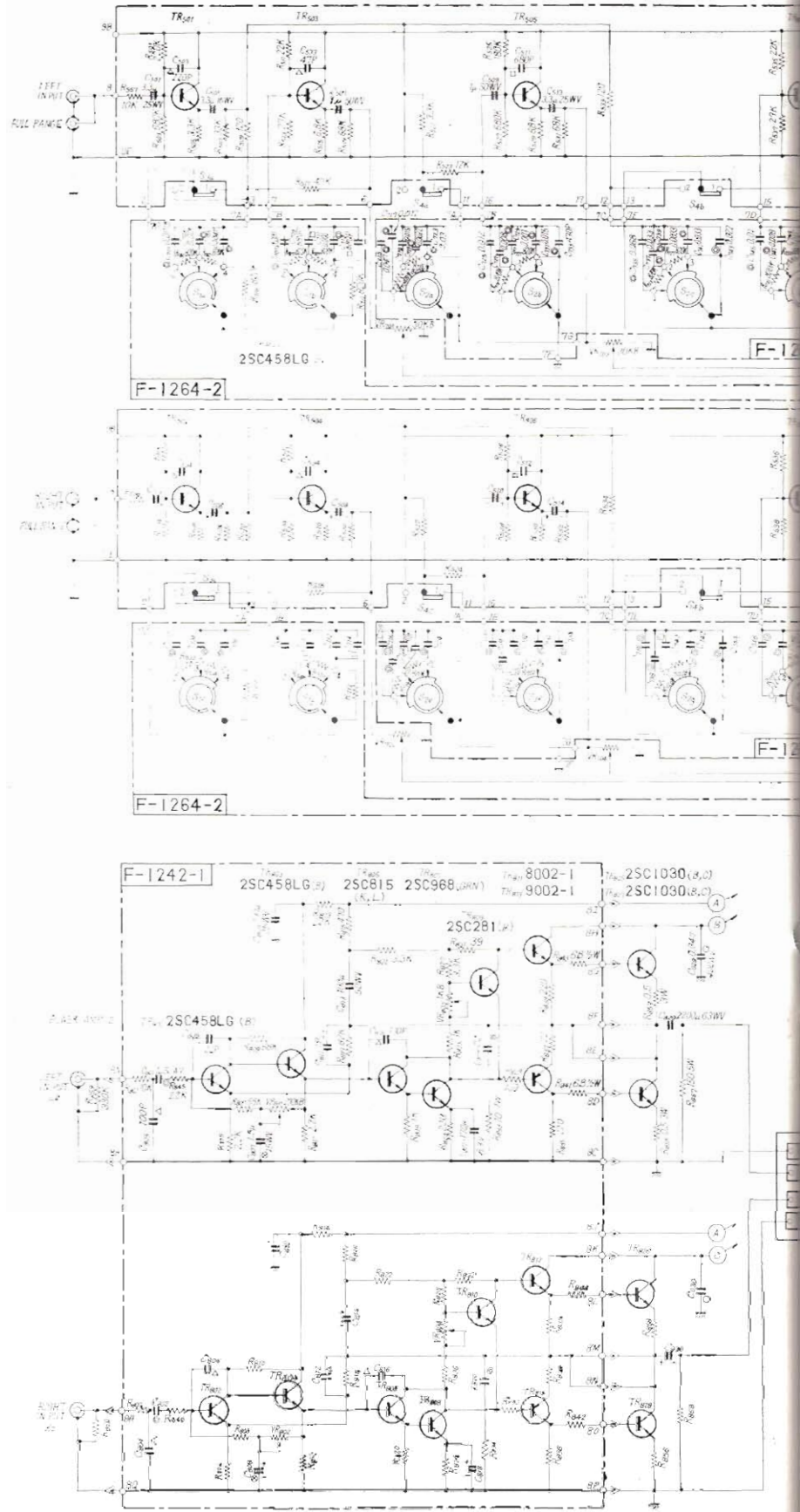

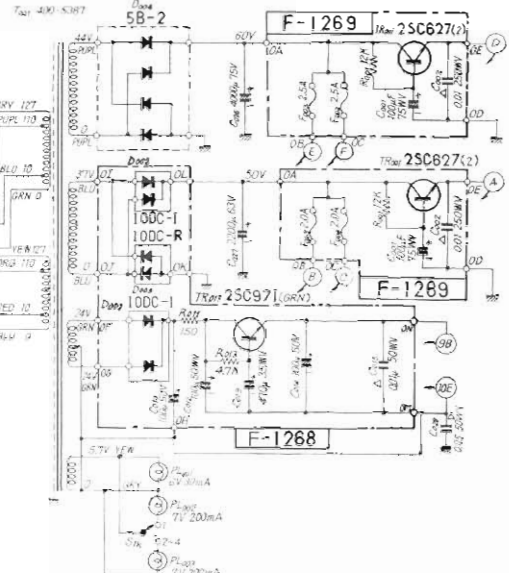
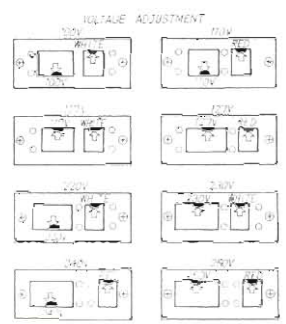
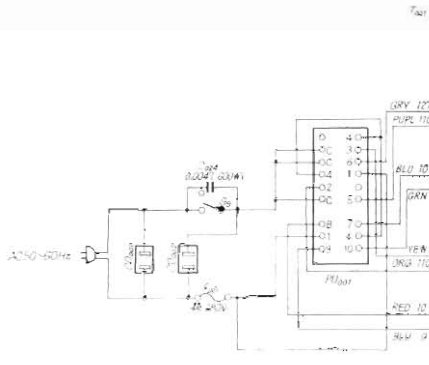
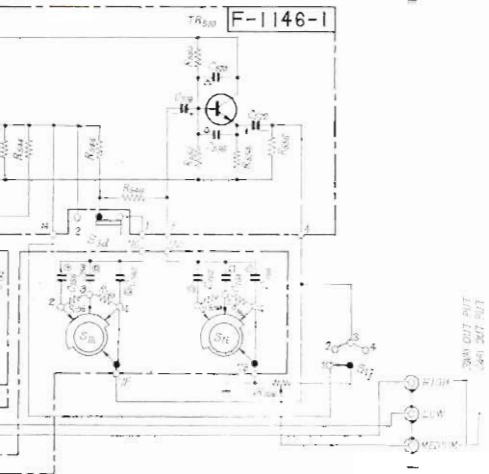
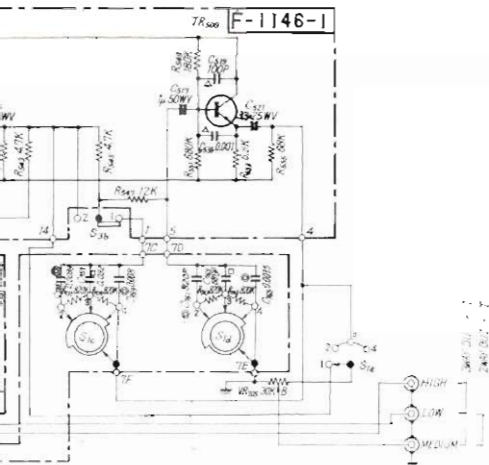

- S_{1(a)-3} CROSSOVER SW
 1 20K/100K
 2 20K/100K
 3 100K/100K
 4 20K/100K
- S_{1(a)-4} CROSSOVER SW
 1 40K/100K
 2 60K/100K
 3 100K/100K
 4 20K/100K
- S_{2(a)-2} HIGH
 1 2.0B/OCT
 2 8.0B/OCT
- S_{2(a)-3} LOW
 1 2.0B/OCT
 2 8.0B/OCT
- S₃ POWER
 ALL RESISTANCES IN OHMS @ 1/4 WATT, ±10% TOLERANCE UNLESS NOTED
 ALL CAPACITORS IN μF UNLESS NOTED
- VR₁₀₂ VR₁₀₃ HIGH LEVEL Adj
 VR₁₀₄ VR₁₀₅ LOW LEVEL Adj
 VR₁₀₆ VR₁₀₇ MEDIUM LEVEL Adj
- CAPACITOR SYMBOL
 △ CERAMIC
 ○ MYLAR
 □ OIL
 □ MICA
 ⊗ TANTALUM

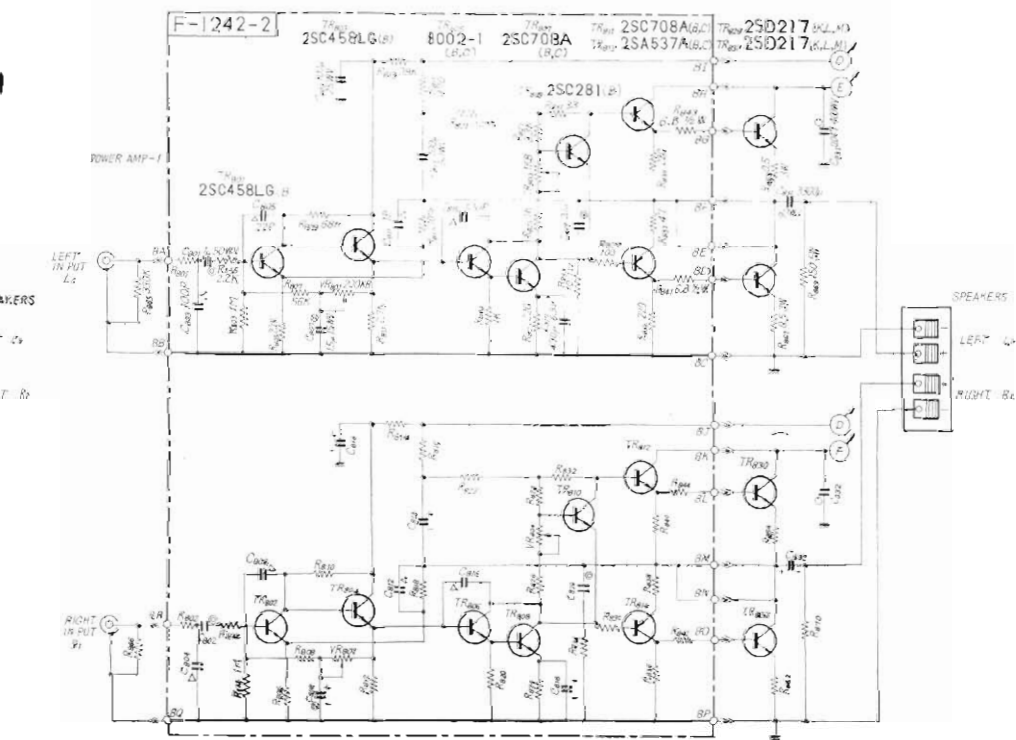

ALIGNMENT

CURRENT ADJUSTMENT OF POWER AMPLIFIERS

STEP	AMMETER (TESTER)	CONNECTION & ADJUSTMENT	REMARKS
1.		Remove F ₀₀₃ (F ₀₀₅) and F ₀₀₂ (F ₀₀₄).	Use ammeter having 50 or 100mA range
2.		Set resistance of VR ₈₀₃ and VR ₈₀₄ to maximum.	
3.	Set to 100mA range.	Turn power switch on and connect ammeter in place of F ₀₀₃ (F ₀₀₅). Its ⊕ terminal should be connected to OA and ⊖ terminal to OB in schematic diagram.	Be sure to connect ammeter after turning power switch on.
4.		Turn VR ₈₀₃ little by little and adjust current to 30mA.	
5.		Turn power switch off and reset F ₀₀₃ (F ₀₀₅) in its original position.	
6.	Set to 100mA range.	Turn power switch on and connect ammeter in place of F ₀₀₂ (F ₀₀₄). Its ⊕ terminal should be connected to OA and ⊖ terminal to OC in schematic diagram.	Be sure to connect ammeter after turning power switch on.
7.		Turn VR ₈₀₄ little by little and adjust current to 30mA.	
8.		Turn power switch off and reset F ₀₀₂ (F ₀₀₄) in its original position.	
9.		Adjust current of power amplifier 2 as indicated above but parenthesized.	

OUTPUT ADJUSTMENT OF POWER AMPLIFIERS

STEP	CONNECTION & ADJUSTMENT	REMARKS
1.	Set oscillator to 1,000 Hz and its output to minimum, and connect it to L-(R-) channel input of power amplifier 1.	Use oscillator having oscillation frequency of 20 to 20,000 Hz and output voltage of more than 500mV
2.	Connect an 8- or 16-ohm load resistor (minimum rating of 50 watts) to L-(R-) channel speaker terminal of power amplifier 1.	
3.	Connect oscilloscope to speaker terminal.	
4.	Turn power switch on and advance oscillator output little by little to check whether output appears at speaker terminal by means of oscilloscope.	
5.	Adjust VR ₈₀₁ (VR ₈₀₂) so that both crests of output wave form are clipped simultaneously.	
6.	For adjustment of output in R-channel, follow same procedure as indicated above but parenthesized.	
7.	Adjust output of power amplifier 2 as above.	

TEAST POINT

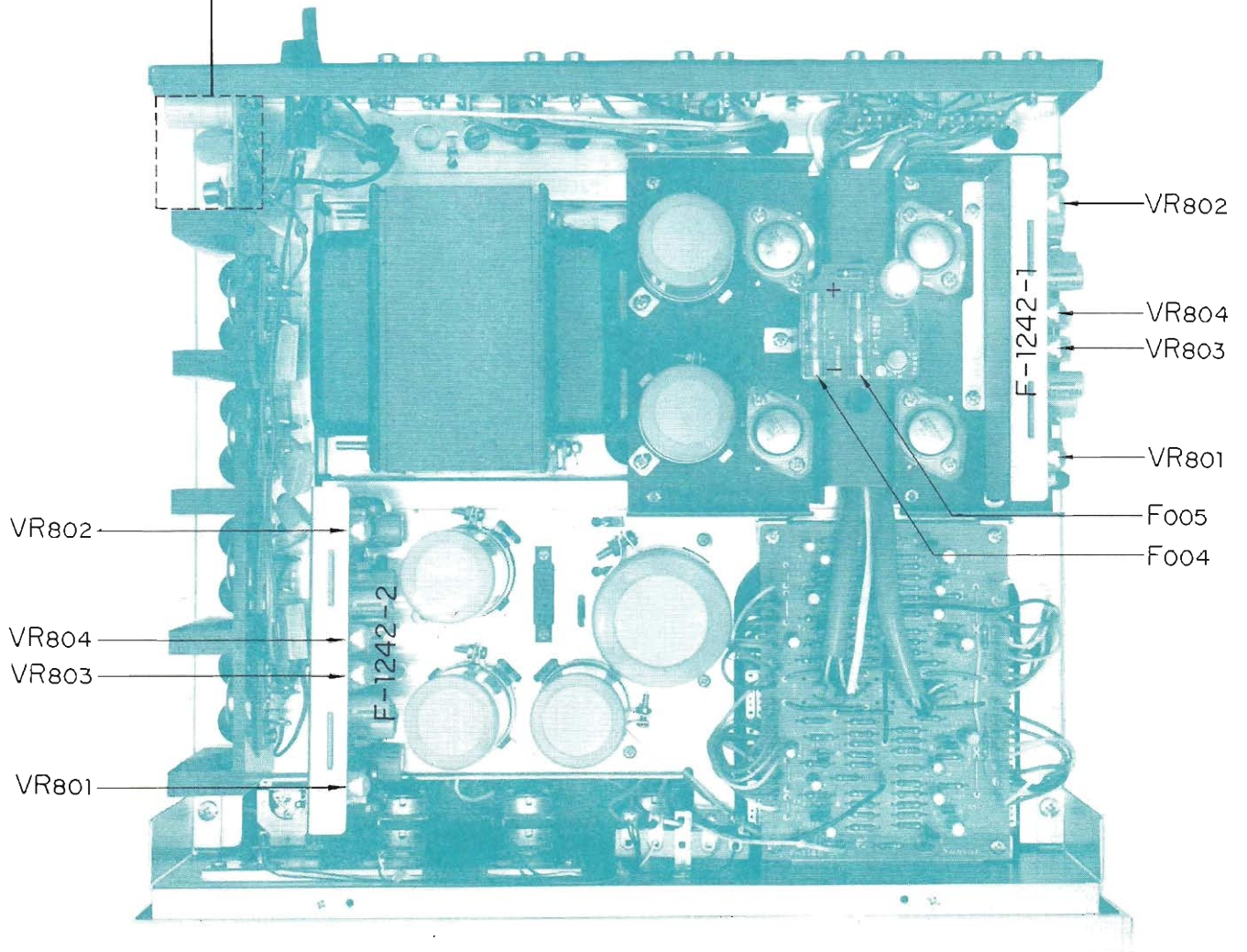
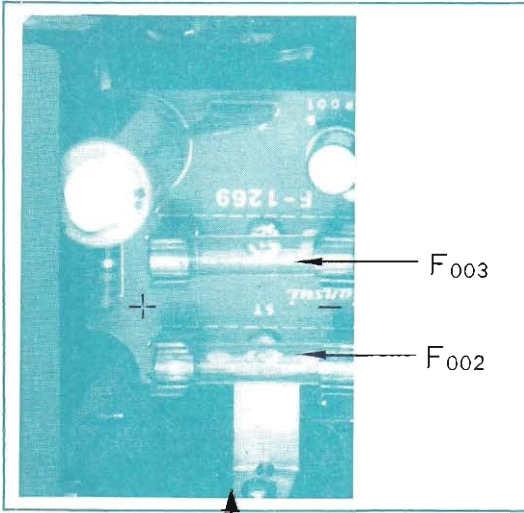

BLOCK DIAGRAM

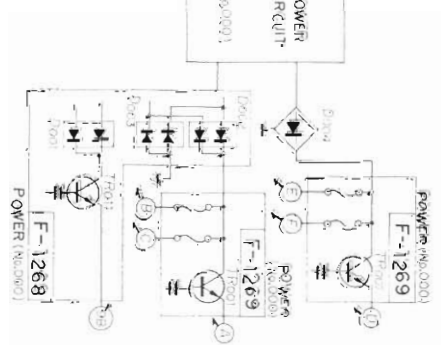
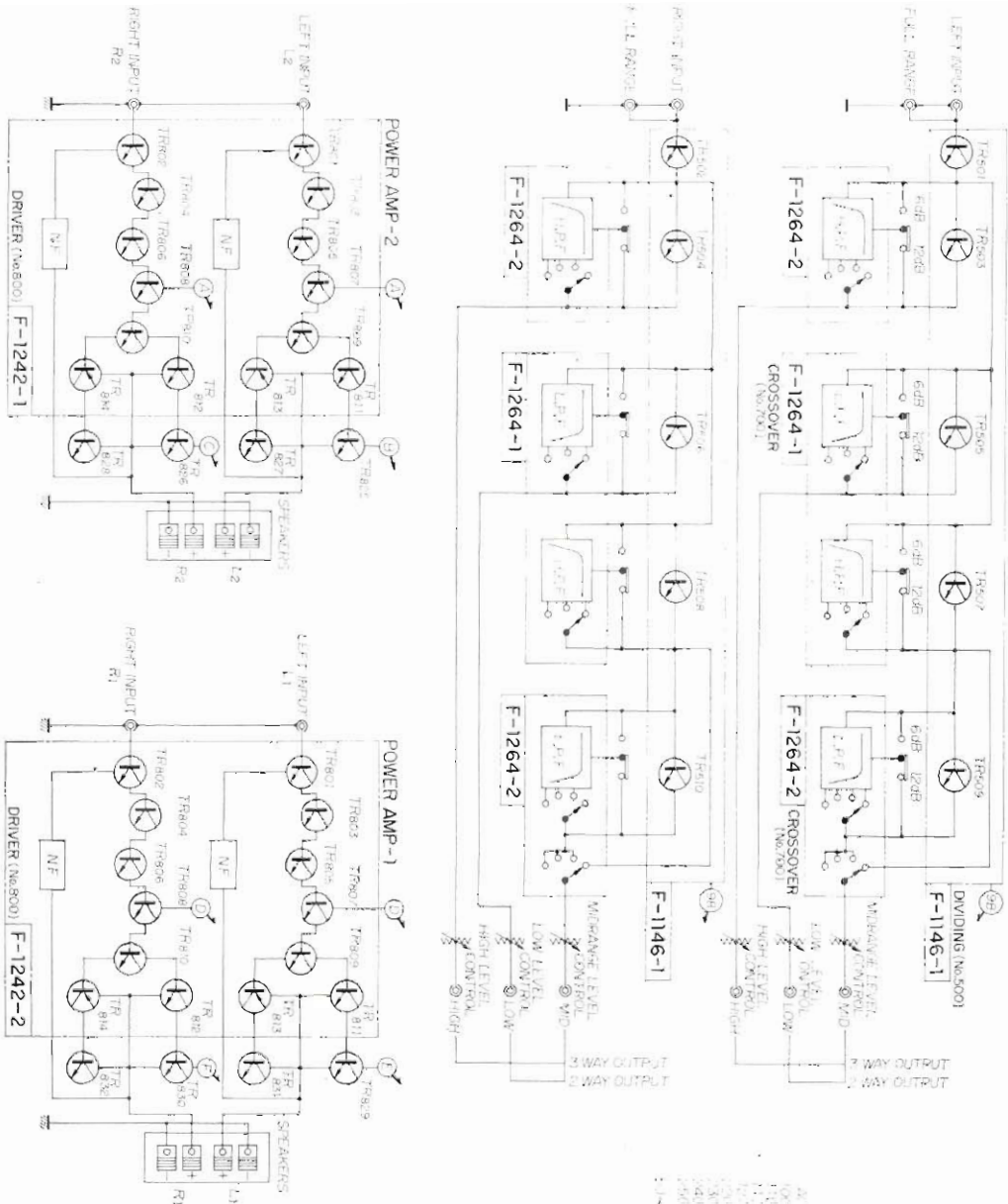

DISASSEMBLY PROCEDURE

REMOVING THE WOOD CASE

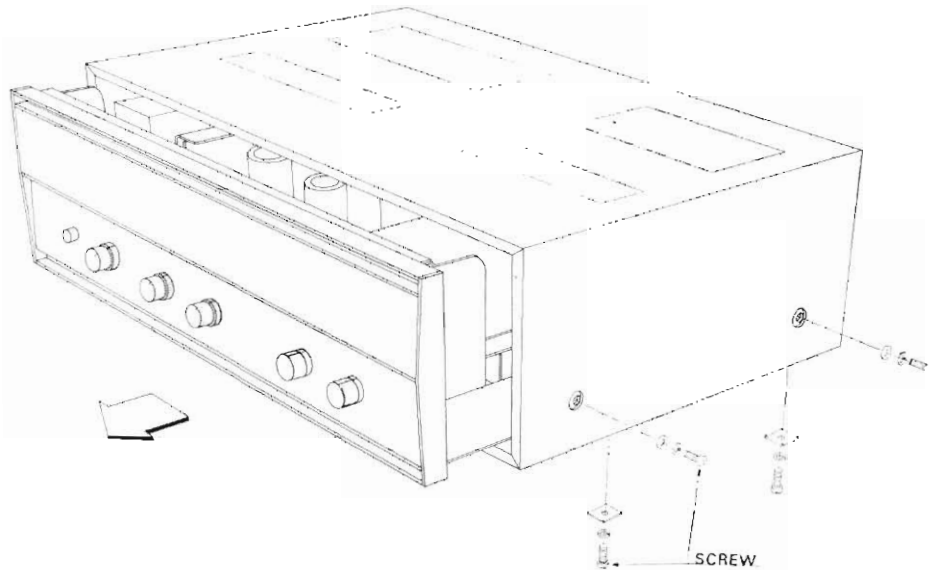

REMOVING THE FRONT PANEL, AND BOTTOM BOARDS

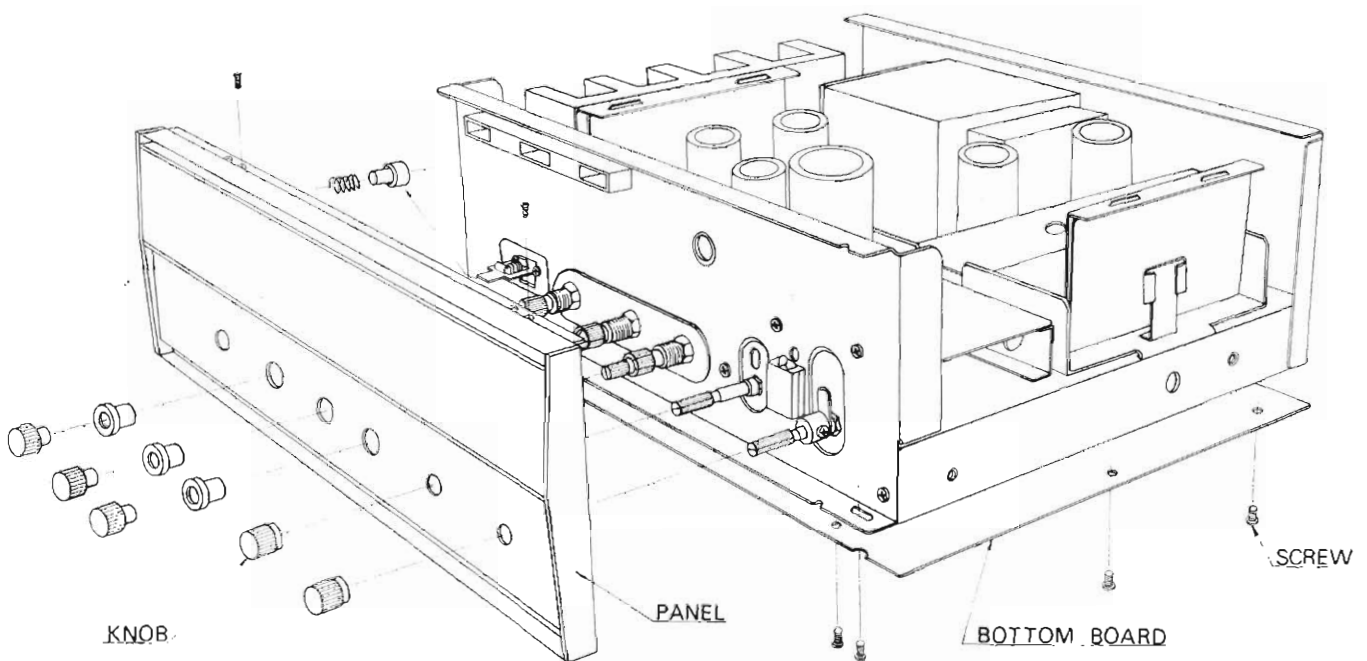

CUSTOM MOUNTING

How to Install the Amplifier in a Custom Cabinet

1. Make a Cabinet window of 353mm or $13\frac{29}{32}$ " in width and 117mm or $4\frac{39}{64}$ " in height.
2. Place two square pieces of wood ($20 \times 20 \times 240$ mm or $\frac{25}{32}$ " \times $\frac{25}{32}$ " \times $9\frac{29}{64}$ ") for supporting the amplifier in the bottom board of the cabinet.
3. Cut two holes for attachment bolts on the bottom board of the cabinet.
4. Remove the amplifier from the wood case (Refer to the section entitled 'DISASSEMBLY PROSEDURE').
5. Place the amplifier in position throuh the cabinet window.
6. Make sure the amplifier is in position, then put the washers in butterfly bolts (4 \times 40mm) and fix the amplifier to the cabinet with the butterfly bolts.

Note: When the amplifier is built into the custom cabinet, the wood case assembly including screws and washers is not used. Retain it for future use.

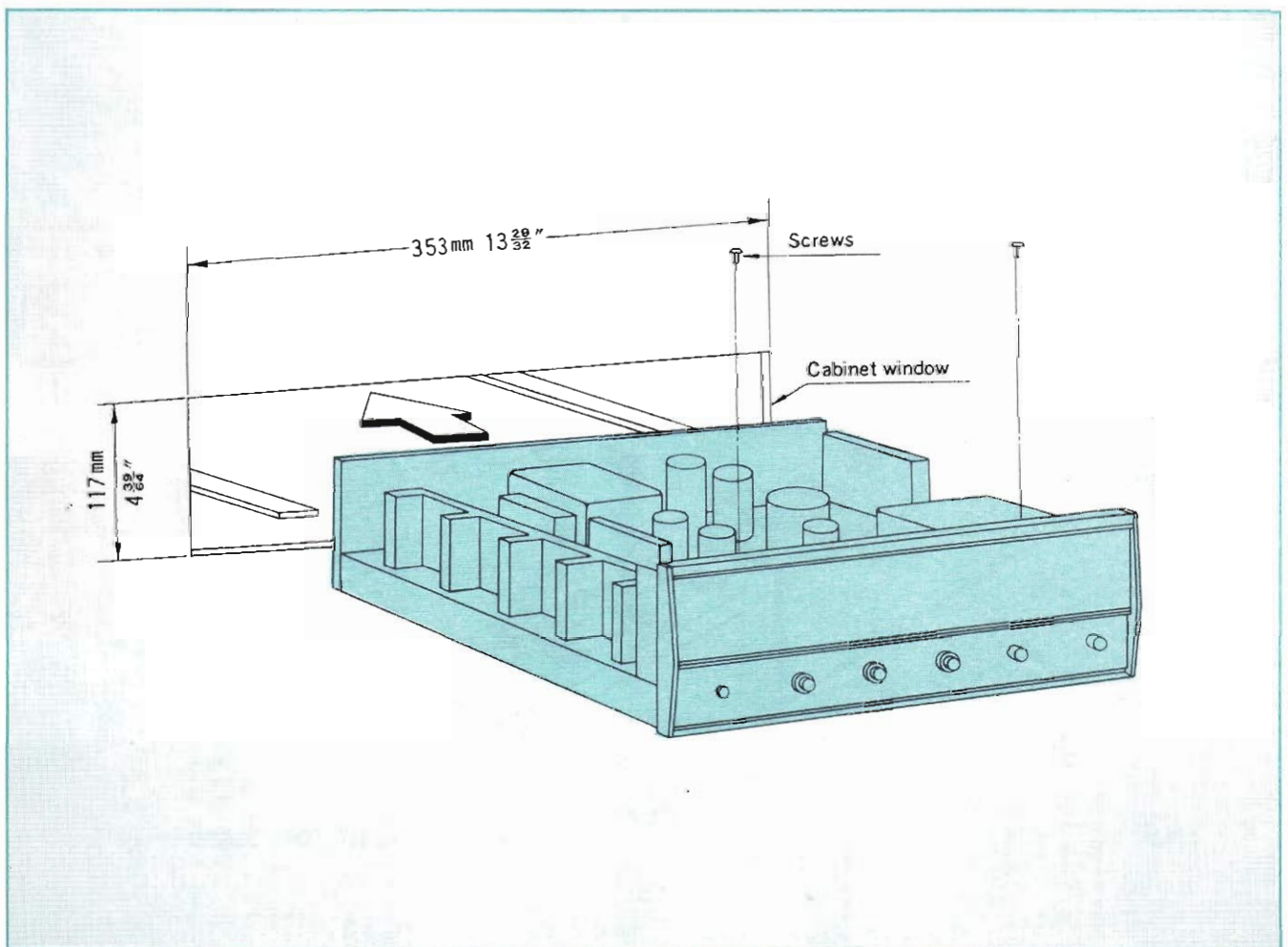

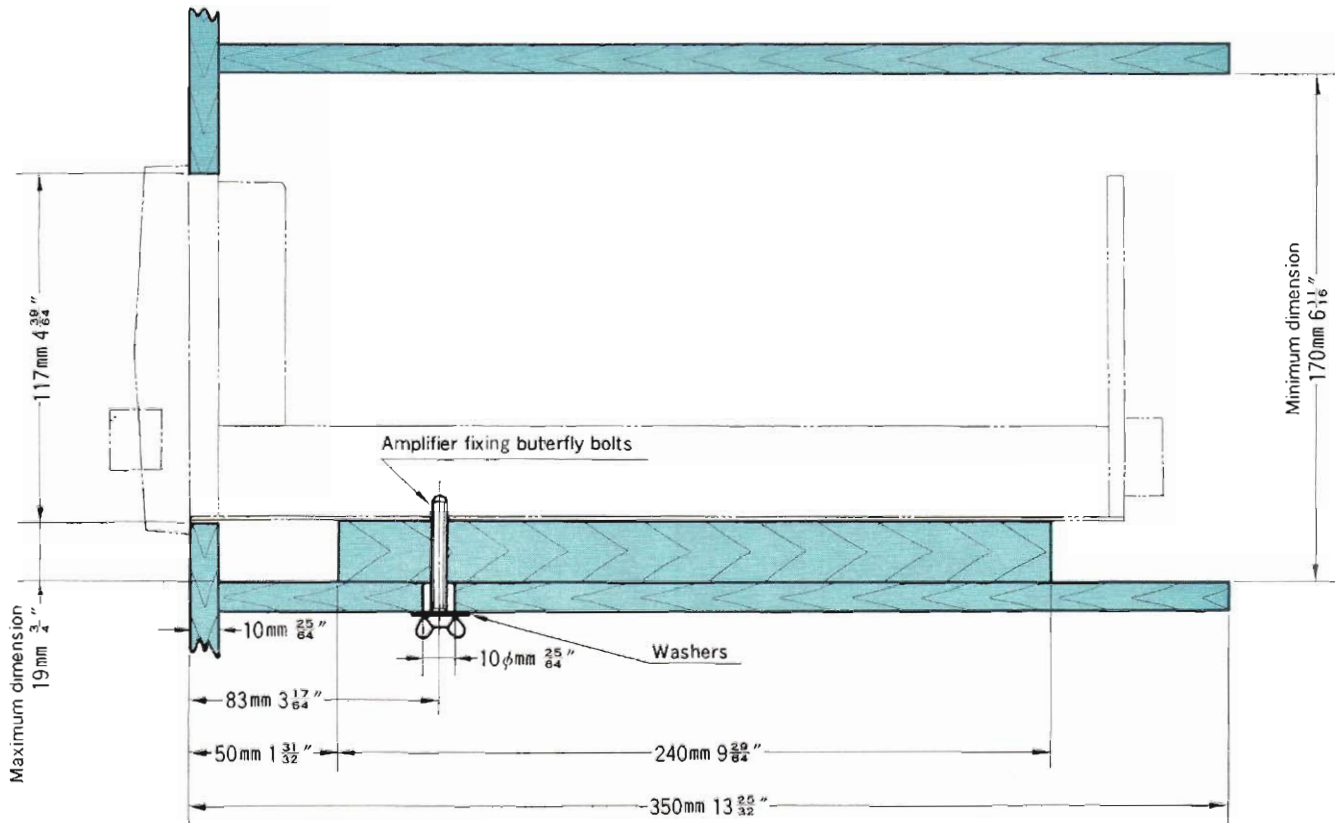
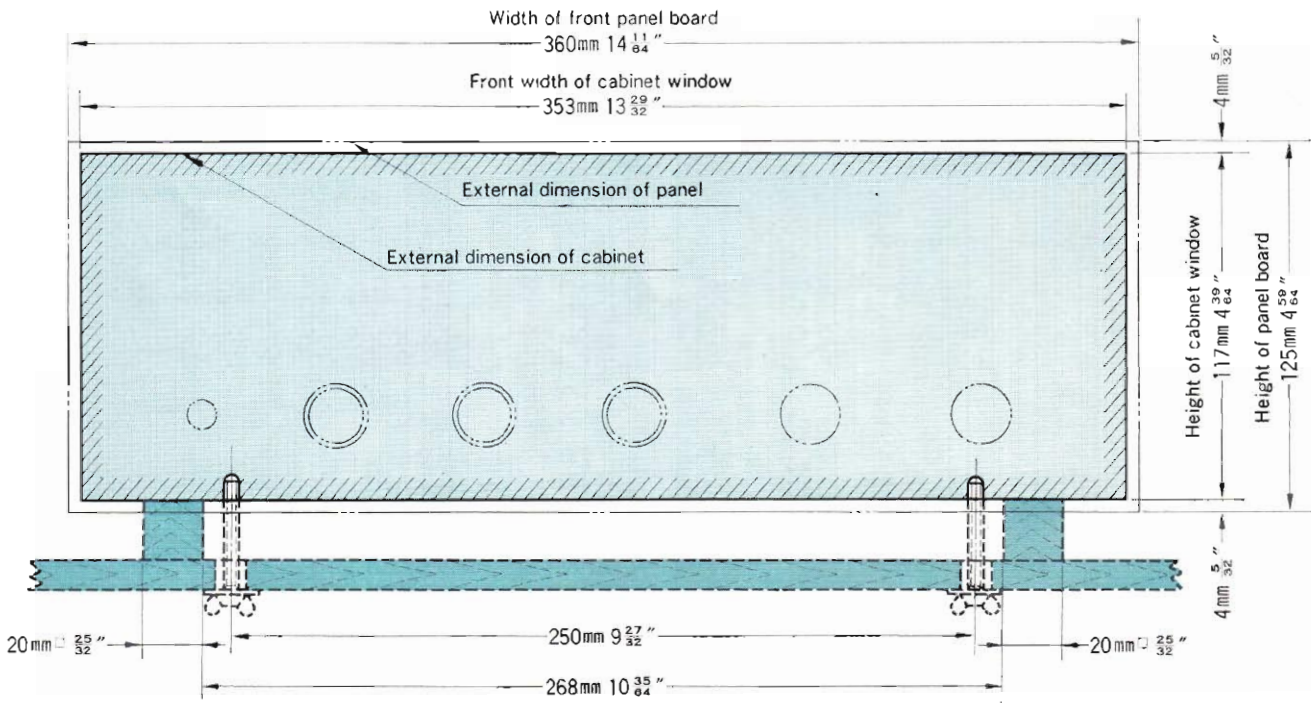

PRINTED CIRCUIT BOARDS AND PARTS LIST

X: Parts No Y: Parts Name Z: Position of Parts

DRIVER BLOCK <F-1242-1>

X	Y	Z
R801	10k Ω	2 A
R802	10k Ω	2 C
R805	2.2k Ω	1 A
R806	2.2k Ω	1 C
R807	56k Ω	1 A
R808	56k Ω	1 C
R809	68k Ω	1 A
R810	68k Ω	1 C
R811	2.2k Ω	1 A
R812	2.2k Ω	1 C
R813	22k Ω	1 B
R814	22k Ω	1 B
R815	470 Ω	1 B
R816	470 Ω	1 B
R817	82k Ω	1 A
R818	82k Ω	1 C
R819	1k Ω	2 A
R820	1k Ω	2 C
R821	3.3k Ω	1 B
R822	3.3k Ω	1 B
R823	220 Ω	2 A
R824	220 Ω	2 C
R825	1k Ω	1 B
R826	1k Ω	1 B
R827	3.3k Ω	1 B
R828	3.3k Ω	1 B
R829	100 Ω	2 A
R830	100 Ω	2 C
R831	39 Ω	2 B
R832	39 Ω	2 B
R833	10 Ω	2 A, B
R834	10 Ω	2 B, C
R835	220 Ω	2 A
R836	220 Ω	2 C
R837	22 Ω	2 A
R838	22 Ω	2 C
R839	220 Ω	2 B
R840	220 Ω	2 B
R841	6.8 Ω	2 A
R842	6.8 Ω	2 C
R843	6.8 Ω	2 B
R844	6.8 Ω	2 B
R845	2.2k Ω	1 A
R846	2.2k Ω	1 C
VR801	200k Ω (B)	1 A
VR802	200k Ω (B)	1 C
VR803	1k Ω (B)	1 B
VR804	1k Ω (B)	1 B
C801	1 μ F	1 A
C802	1 μ F	1 C
C803	100pF	2 A
C804	100pF	2 C
C805	22pF	1 A
C806	22pF	1 C
C807	1.5 μ F	1 A
C808	1.5 μ F	1 C

X	Y	Z
C809	100 μ F	1 A, B
C810	100 μ F	1 B, C
C811	1pF	1 A
C812	1pF	1 C
C813	100 μ F	1 A
C814	100 μ F	1 C
C815	100pF	1 A
C816	100pF	1 C
C817	470 μ F	2 A
C818	470 μ F	2 C
C819	0.1 μ F	2 A
C820	0.1 μ F	2 C
TR801	2SC458LG(B)	1 A
TR802	2SC458LG(B)	1 C
TR803	2SC458LG(B)	1 A
TR804	2SC458LG(B)	1 C
TR805	2SC815(L, K)	1 A
TR806	2SC815(L, K)	1 C
TR807	2SC968(GRN)	2 A
TR808	2SC968(GRN)	2 C
TR809	2SC281 White(B)	1 B
TR810	2SC281 White(B)	1 B
TR811	CDC8002-1(A)	2 B
TR812	CDC8002-1(A)	2 B
TR813	CDC9002-1(A)	2 A, B
TR814	CDC9002-1(A)	2 B, C

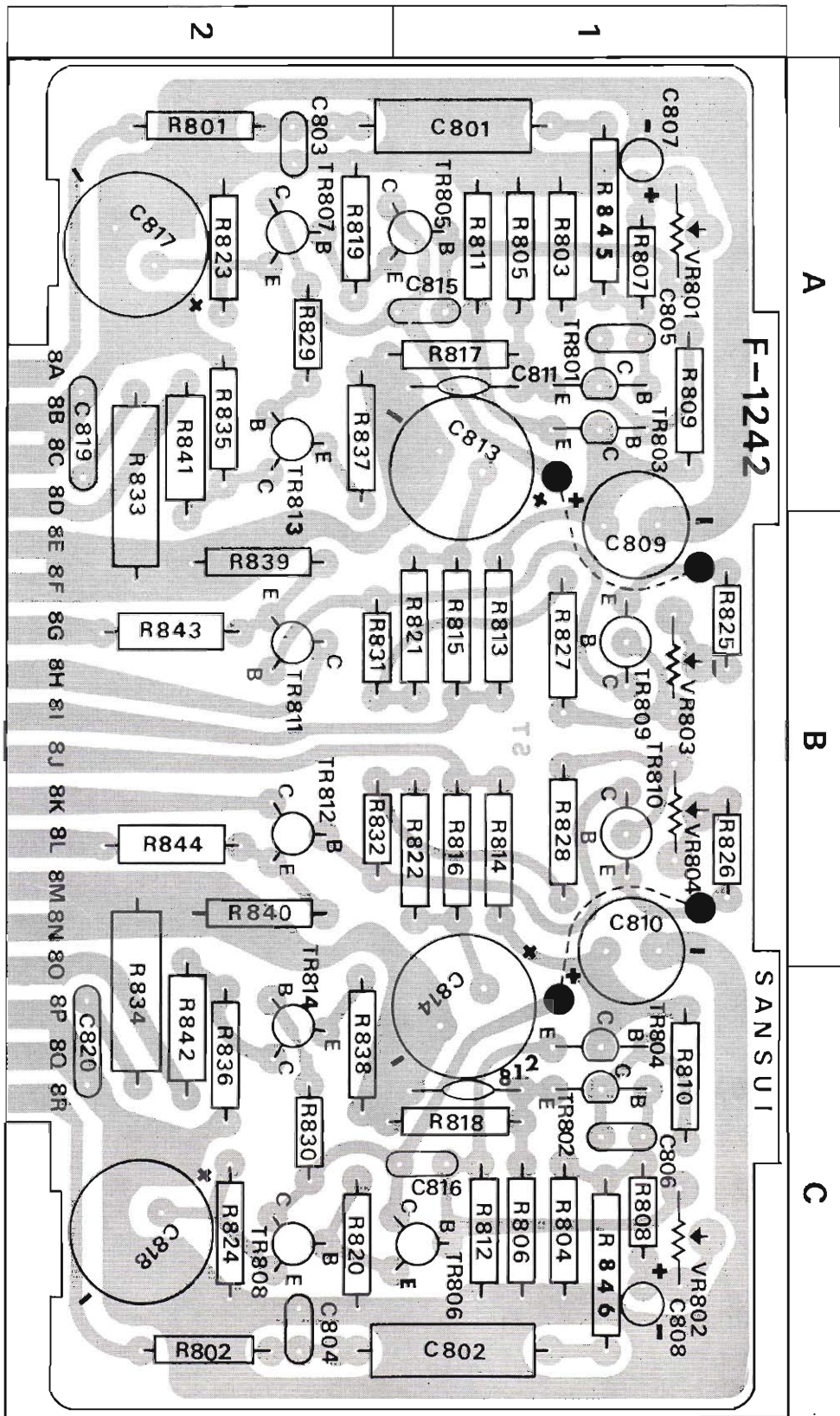

PRINTED CIRCUIT BOARDS AND PARTS LIST

X: Parts No Y: Parts Name Z: Position of Parts

DRIVER BLOCK <F-1242-2>

X	Y	Z
R801	10k Ω	2A
R802	10k Ω	2C
R803	1M Ω	1A
R804	1M Ω	1C
R805	2.2k Ω	1A
R806	2.2k Ω	1C
R807	56k Ω	1A
R808	56k Ω	1C
R809	68k Ω	1A
R810	68k Ω	1C
R811	2.7k Ω	1A
R812	2.7k Ω	1C
R813	39k Ω	1B
R814	39k Ω	1B
R815	470 Ω	1B
R816	470 Ω	1B
R817	100k Ω	1A
R818	100k Ω	1C
R819	1k Ω	2A
R820	1k Ω	2C
R821	3.9k Ω	1B
R822	3.9k Ω	1B
R823	220 Ω	2A
R824	220 Ω	2C
R825	1k Ω	1B
R826	1k Ω	1B
R827	3.3k Ω	1B
R828	3.3k Ω	1B
R829	100 Ω	2A
R830	100 Ω	2C
R831	33 Ω	2B
R832	33 Ω	2B
R833	10 Ω	2A, B
R834	10 Ω	2B, C
R835	220 Ω	2A
R836	220 Ω	2C
R837	47 Ω	2A
R838	47 Ω	2C
R839	220 Ω	2B
R840	220 Ω	2B
R841	6.8 Ω	2A
R842	6.8 Ω	2C
R843	6.8 Ω	2B
R844	6.8 Ω	2B
R845	2.2k Ω	1A
R846	2.2k Ω	1C
VR801	200k Ω (B)	1A
VR802	200k Ω (B)	1C
VR803	1k Ω (B)	1B
VR804	1k Ω (B)	1B
C801	1 μ F	1A
C802	1 μ F	1C
C803	100pF	2A
C804	100pF	2C
C805	22pF	1A
C806	22pF	1C

X	Y	Z
C807	1.5 μ F	1A
C808	1.5 μ F	1C
C809	100 μ F	1A, B
C810	100 μ F	1B, C
C811	1pF	1A
C812	1pF	2D
C813	100 μ F	1A
C814	100 μ F	1C
C815	100pF	1A
C816	100pF	1C
C817	470 μ F	2A
C818	470 μ F	2C
C819	0.1 μ F	2A
C820	0.1 μ F	2C
TR801	2SC458LG(B)	1A
TR802	2SC458LG(B)	1C
TR803	2SC458LG(B)	1A
TR804	2SC458LG(B)	1C
TR805	CDC8002-1(A)	1A
TR806	CDC8002-1(A)	1C
TR807	2SC708A(B,C)	2A
TR808	2SC708A(B,C)	2C
TR809	2SC281 White(B)	1B
TR810	2SC281 White(B)	1B
TR811	2SC708A(B,C)	2B
TR812	2SC708A(B,C)	2B
TR813	2SA537A(B,C)	2A, B
TR814	2SA537A(B,C)	2B, C

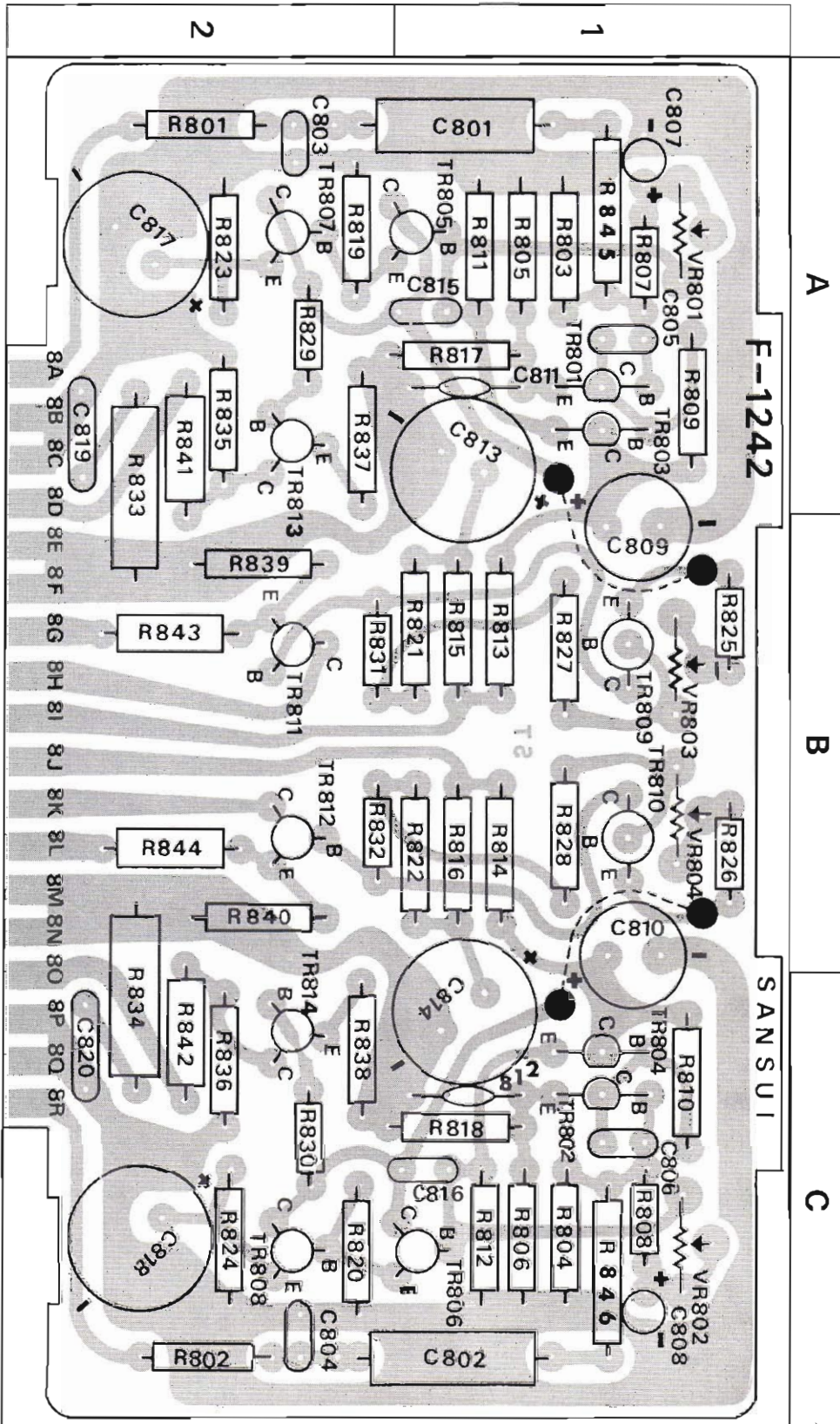

PRINTED CIRCUIT BOARDS AND PARTS LIST

X: Parts No Y: Parts Name Z: Position of Parts

DIVIDING BLOCK <F-1146-1>

X	Y	Z
R501	220k Ω	2 D
R502	220k Ω	2 A
R503	680k Ω	2 D
R504	680k Ω	2 A
R505	3.3k Ω	2 D
R506	3.3k Ω	2 A
R507	33k Ω	2 D
R508	33k Ω	2 A
R509	120 Ω	1, 2 C
R510	120 Ω	1, 2 B
R511	22k Ω	1 D
R512	22k Ω	1 A
R513	27k Ω	2 D
R514	27k Ω	2 A
R515	6.8k Ω	2 D
R516	6.8k Ω	2 A
R517	4.7k Ω	1 C
R518	4.7k Ω	1 B
R519	68k Ω	2 D
R520	68k Ω	2 A
R521	3.3k Ω	2 C
R522	3.3k Ω	2 B
R523	12k Ω	2, 3 D
R524	12k Ω	2, 3 A
R525	180k Ω	3 D
R526	180k Ω	3 A
R527	680k Ω	2 D
R528	680k Ω	2 A
R529	6.8k Ω $\pm 10\%$ $\frac{1}{4}W$ Carbon Resistor	2 D
R530	6.8k Ω	2 A
R531	68k Ω	2 D
R532	68k Ω	2 A
R533	120 Ω	3 C
R534	120 Ω	3 B
R535	22k Ω	3 C
R536	22k Ω	3 B
R537	27k Ω	2 C
R538	27k Ω	2 B
R539	6.8k Ω	2 C
R540	6.8k Ω	2 B
R541	68k Ω	2 C
R542	68k Ω	2 B
R543	4.7k Ω	3 C
R544	4.7k Ω	3 B
R545	4.7k Ω	2 C
R546	4.7k Ω	2 B
R547	12k Ω	2 C
R548	12k Ω	2 B
R549	180k Ω	1 C
R550	180k Ω	1 B
R551	680k Ω	2 C
R552	680k Ω	2 B
R553	6.8k Ω	2 C
R554	6.8k Ω	2 B
R555	68k Ω	2 C
R556	68k Ω	2 B
R557	10k Ω	3 D
R558	10k Ω	3 A

X	Y	Z
C501	3.3 μF } 50WV Electrolytic	3 D
C502	3.3 μF } Capacitor	3 A
C503	220 pF } $\pm 10\%$ 50WV Ceramic	1, 2 D
C504	220 pF } Capacitor	1, 2 A
C505	3.3 μF } 50WV Electrolytic	1 D
C506	3.3 μF } Capacitor	1 A
C507	1 μF } 50WV Electrolytic	1 D
C508	1 μF } Capacitor	1 A
C509	1 μF } 50WV Electrolytic	3 D
C510	1 μF } Capacitor	3 A
C511	680 pF } $\pm 10\%$ 50WV Mico Capacitor	3 D
C512	680 pF } Capacitor	3 A
C513	3.3 μF } 50WV Electrolytic	3 D
C514	3.3 μF } Capacitor	3 A
C515	3.3 μF } 50WV Electrolytic	3 C
C516	3.3 μF } Capacitor	3 B
C517	1 μF } 50WV Electrolytic	1 C
C518	1 μF } Capacitor	1 B
C519	100 pF } $\pm 10\%$ 50WV Ceramic	1 C
C520	100 pF } Capacitor	1 B
C521	3.3 μF } 50WV Electrolytic	1 C
C522	3.3 μF } Capacitor	1 B
C533	47 pF } $\pm 10\%$ 50WV Ceramic	
C534	47 pF } Capacitor	
C535	0.001 μF } 50WV Ceramic	
C536	0.001 μF } Capacitor	
TR501	2SC458LG(B, C)	2 D
TR502	2SC458LG(B, C)	2 A
TR503	2SC458LG(B, C)	1 D
TR504	2SC458LG(B, C)	1 A
TR505	2SC458LG(B, C)	3 D
TR506	2SC458LG(B, C) (030531,-1)	3 A
TR507	2SC458LG(B, C)	3 C
TR508	2SC458LG(B, C)	3 B
TR509	2SC458LG(B, C)	1 C
TR510	2SC458LG(B, C)	1 B

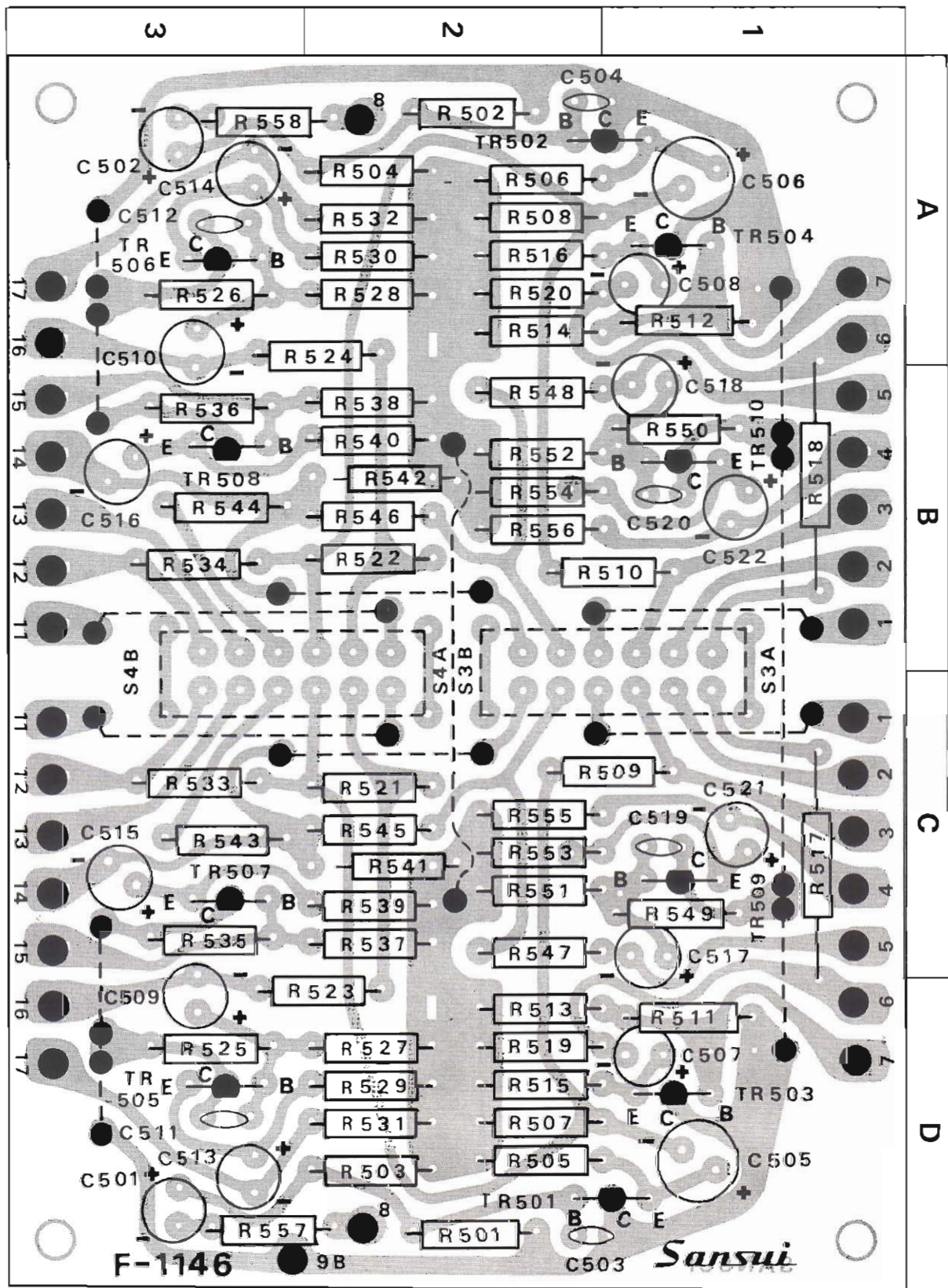

PRINTED CIRCUIT BOARDS AND PARTS LIST

X: Parts No Y: Parts Name

CROSSOVER BLOCK <F-1264-1>

X	Y	
R713~716	820kΩ } ±10% ¼W Solid Resistor	
R719~722		
R725~728		
R731~734		
C715	0.047μF } ±10% 50WV Mylar Capacitor	
C716		
C717		
C718		
C719		
C720		
C721		
C722		
C723		
C724		
C725		
C726		
C727		
C728		
C729		
C730		
C731		
C732		
C733		450 pF } ±10% 50WV Mica Capacitor
C734		
C735	0.068μF } ±10% 50WV Mylar Capacitor	
C736		
C737		
C738		
C739		
C740		
C741		
C742		
C743		
C744		
C745	0.01μF } ±10% 50WV Mylar Capacitor	
C746		
C747		
C748		
C749		
C750		
C751		
C752		
S2(a~h)	Crossover Selector 4-8-3 (110417-1)	

CROSSOVER BLOCK <F-1264-2>

X	Y	
R701~712	820kΩ } ±10% ¼W Solid Resistor	
R737~740		
R743~746		
C701	0.0015μF } ±10% 50WV Mylar Capacitor	
C702		
C703		
C704		
C705		
C706		
C707		
C708		
C709		680 pF } ±10% 50WV Mica Capacitor
C710		
C711	0.001μF } ±10% 50WV Mylar Capacitor	
C712		
C713	680 pF } ±10% 50WV Mica Capacitor	
C714		
C755	0.0033μF } ±10% 50WV Mylar Capacitor	
C756		
C757		
C758		
C759	0.008μF } ±10% 50WV Mylar Capacitor	
C760		
C761	820 pF } ±10% 50WV Mica Capacitor	
C762		
C763		
C764	680 pF } ±10% 50WV Mylar Capacitor	
C765		
C766		
S1(a~f)	Crossover Selector 5-10-4 (110506-1)	

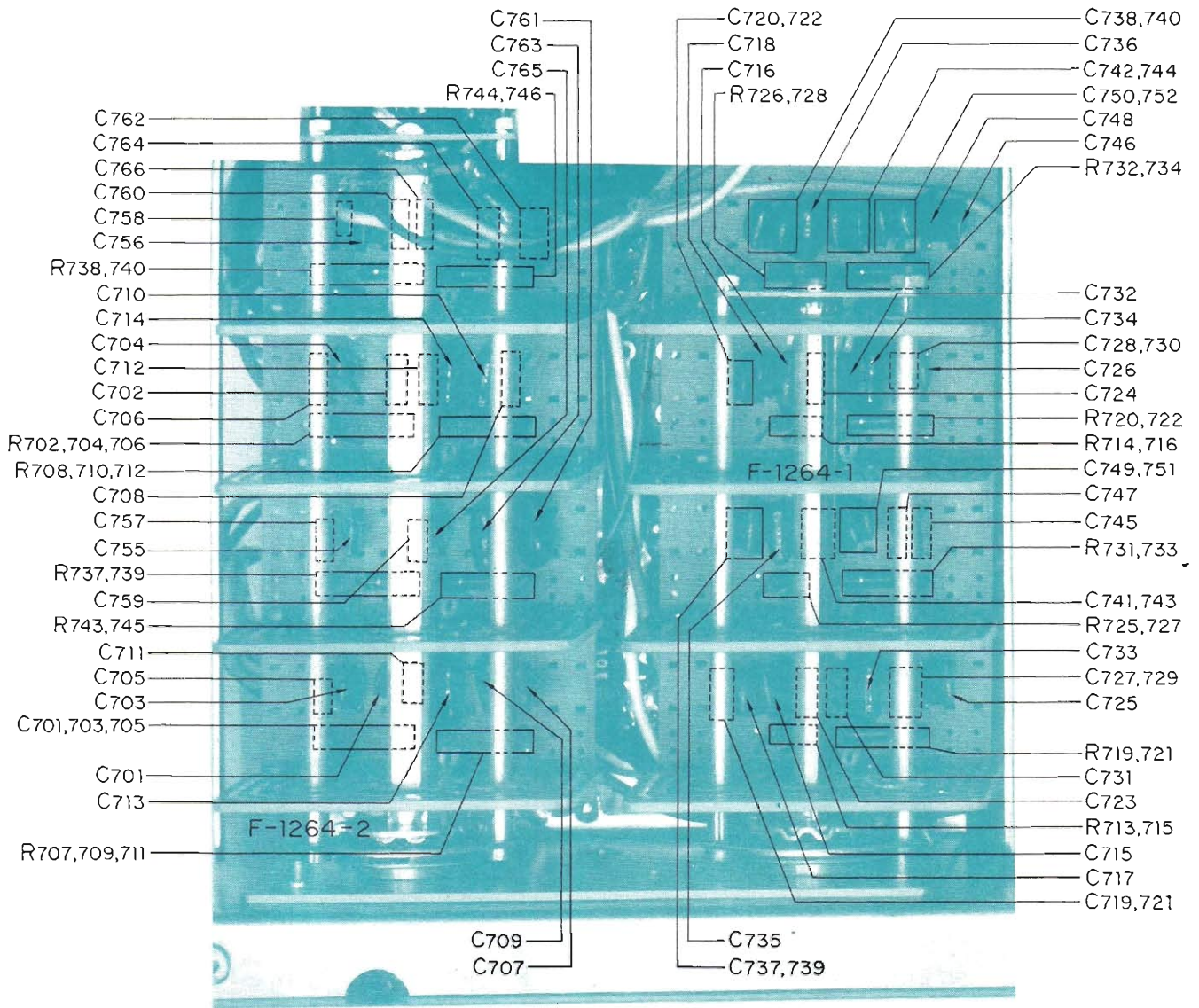

PRINTED CIRCUIT BOARDS AND PARTS LIST

X: Parts No Y: Parts Name Z: Position of Parts

POWER BLOCK <F-1268>

X	Y	Z
R011	150Ω } ± 10% 1/2W Solid Resistor	1 B
R012		1 A
C011	100μF } 50WV Electrolytic Capacitor	1 B
C012		1 B
C013	470μF 35WV Electrolytic Capacitor	1 B
C014	100μF 50WV Electrolytic Capacitor	1 A
C028	0.01μF 50WV Ceramic Capacitor	1 A
TR011	2SC971(3) GRN (030553-3)	1 A
D001	10DC1 (031068)	1 B
D002	10DC1 (031068)	1 A
D003	10DC1R (031067)	1 A

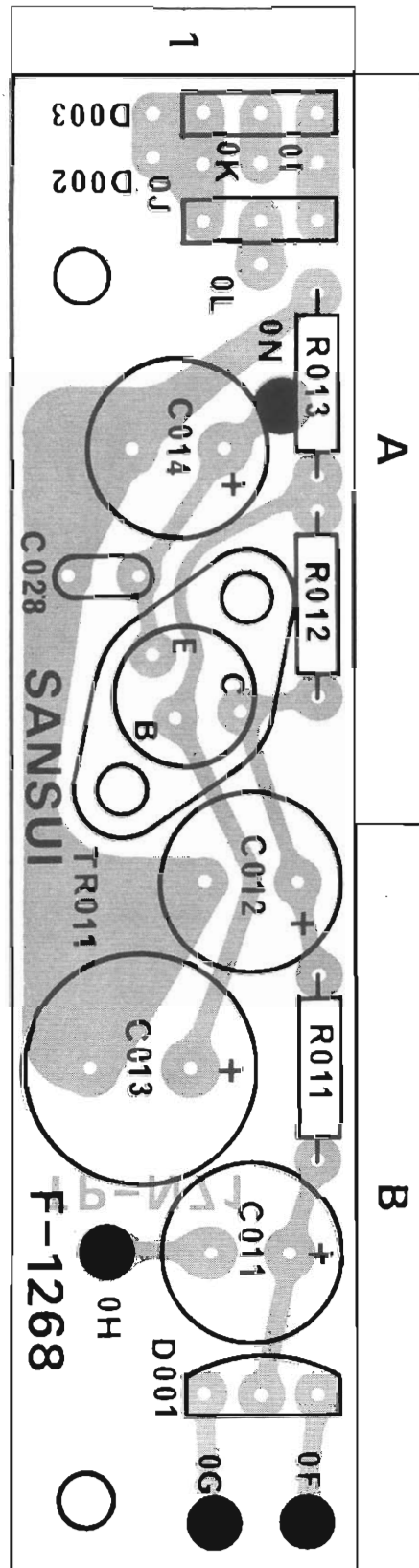

POWER BLOCK <F-1269>

X	Y
R001	12kΩ ±10% ½W Solid Resistor
C001	100μF 75WV Electrolytic Capacitor
C002	0.01μF ±10% 250WV Ceramic Capacitor
TR001	2SC627(2) (030558-1)

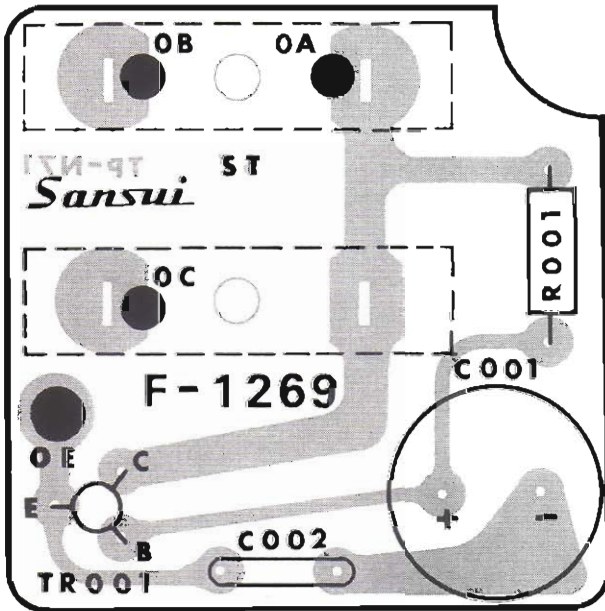

OTHER PARTS AND THEIR POSITION ON CHASSIS

X: Parts No Y: Parts Name

OTHER PARTS LIST

X	Y	
R855	0.5Ω	
R856	0.5Ω	
R857	0.5Ω	
R858	0.5Ω	
R859	330kΩ	
R860	330kΩ	
R861	0.5Ω	
R862	0.5Ω	
R863	0.5Ω	
R864	0.5Ω	
R865	330kΩ	
R866	330kΩ	
R867	150Ω	
R868	150Ω	
R869	150Ω	
R870	150Ω	
VR701,702	30kΩ(B)×2 High Level Adjustor	(102006)
VR703,704	30kΩ(B)×2 Low Level Adjustor	(102006)
VR705,706	30kΩ(B)×2 Midrange Level Adjustor	(102006)
C024	0.0047μF	600WV Oil Capacitor
C026	4000μF	75WV Electrolytic Capacitor
C027	2200μF	63WV Electrolytic Capacitor
C028	0.05μF	50WV Ceramic Capacitor
C029	0.047μF	400WV Oil Capacitor
C030	0.047μF	
C031	0.047μF	
C032	0.047μF	
C829	2200μF	63WV Electrolytic Capacitor
C830	2200μF	
C831	3300μF	
C832	3300μF	
TR825	2SC1030(B, C)	(030563-1,2)
TR826	2SC1030(B, C)	
TR827	2SC1030(B, C)	
TR828	2SC1030(B, C)	
TR829	2SD217(K,L,M)	(030827-2,1,0)
TR830	2SD217(K,L,M)	
TR831	2SD217(K,L,M)	
TR832	2SD217(K,L,M)	
D004	5B2	(031066)
PL001	6V 30mA	(040011)
PL002	7V 200mA	(040015)
PL003	7V 200mA	(040015,1)
T001	400-5387 Power Transformer	(400061)
F001	4A Fuse	(043005-1)
F002	2.5A	(043011)
F003	2.5A	(043011)
F004	2A	(043024)
F005	2A	(043024)

X	Y	
CO001	AC Outlet	(245001)
CO002		(245001)
PU001	Power Voltage Selector	(241017)
S1K	2 Way Selector Micro Switch	(241018)
S3(a~b)	Attenuation Selector	(241019)
S4(a~b)		(116007)
S5	Power Switch	(116016)

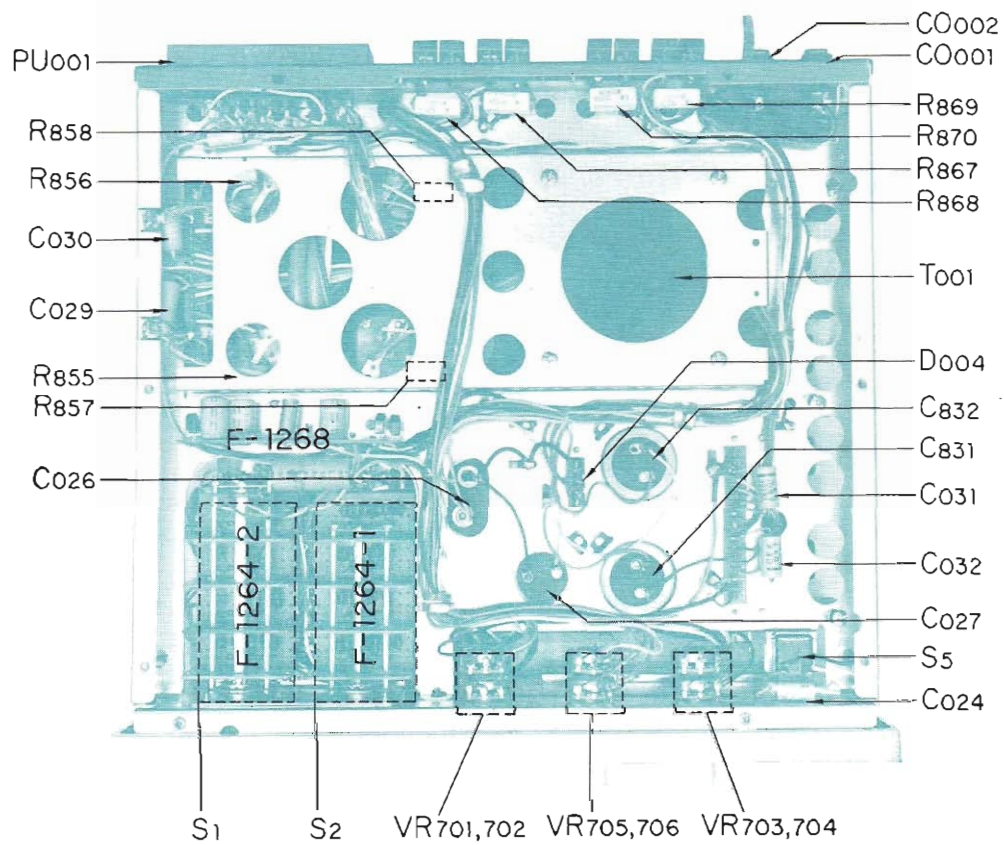
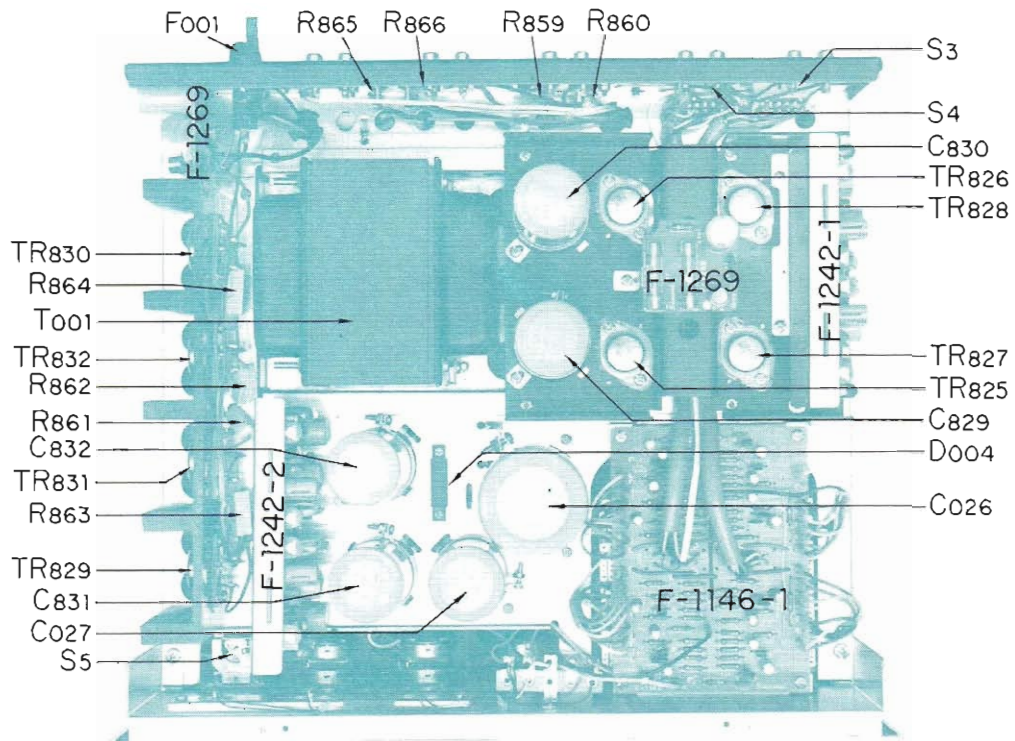

Sansui

SANSUI ELECTRIC COMPANY LIMITED

Head Office; 14-1, 2-chome, Izumi, Suginami-ku, Tokyo, Japan. TEL. 323-1111

Printed in Japan (50020M)