

SERVICE MANUAL

TWO-SPEED AUTO-RETURN TURNTABLE

SANSUI FR-1080



Sansui

SANSUI ELECTRIC CO., LTD.

Notice:

In this service manual, some parts have three types, A, B & C in same parts No. as shown in Parts List. Each type can be identified from Mark on the carton case as Fig. 1.

- TYPE A.....FR-1080
- TYPE B.....FR-1080E
- TYPE C.....FR-1080P

Type	Mark
Type A	No mark
Type B	Mark ⓔ
Type C	Mark Ⓟ

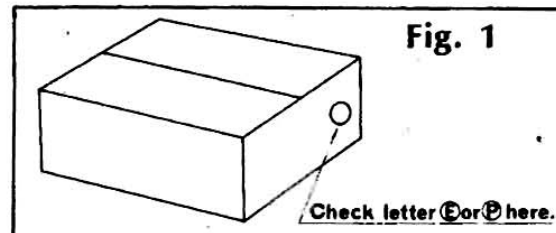

*When ordering parts, please use parts name and the stock No. referring to Parts List.

TABLE OF CONTENTS

<u>Section</u>	<u>Title</u>	<u>Page</u>
1.	SPECIFICATIONS	2
2.	OPERATION OF AUTO MECHANISM	3
3.	ADJUSTMENTS	3
3-1.	Adjusting the Auto Return	3
3-2.	Adjusting the Height of Tonearm Lifter	3
4.	PACKING LIST	4
5.	ACCESSORY PARTS LIST	4
6.	PARTS LOCATIONS & PARTS LISTS	5, 6

1. SPECIFICATIONS

TYPE	Two-speed belt-driven
SPEEDS	33- $\frac{1}{3}$ 45 rpm
PLATTER	Aluminum alloy die-cast 300 mm (11- $\frac{15}{16}$ ") diameter
MOTOR	Four-pole synchronous type
WOW AND FLUTTER	0.08% (W.R.M.S)
S/N	Better than 50dB (IEC-B)
TO NEARM	Statically-balanced S-shaped tubular type
TO NEARM LENGTH	215 mm (8- $\frac{1}{2}$ ")
OVERHANG	10 mm ($\frac{3}{8}$ ")
APPLICABLE CARTRIDGE	
WEIGHT	4 to 8 g
DIMENSIONS	442 mm (17- $\frac{7}{16}$ ") W 155 mm (6- $\frac{1}{8}$ ") H 365.5 mm (14- $\frac{7}{16}$ ") D
WEIGHT	5.5 kg (12.1 lbs) net 8 kg (17.6 lbs) packed
POWER CONSUMPTION	10W (rated) 13W (max.)
CARTRIDGE	Induced magnet type (SC-37)
FREQUENCY RESPONSE	20~20,000 Hz
OUTPUT	3.5 mV per channel (1,000 Hz, 50 mm/sec)
LOAD IMPEDANCE	47 k Ω
TRACKING FORCE	2.5 g
STYLUS	0.5mil, diamond spherical (SN-37)

* Design and specifications subject to change without notice for improvements.

2. OPERATION OF AUTO MECHANISM

- 1) In case that tonearm is left off the arm rest, the PU plate will leave from micro-switch, then the turntable will be automatically switched ON so that the platter will start rotating.
- 2) At the moment when the stylus reaches lead-out groove, Auto-lever linked with PU plate starts pushing Reject-lever toward center of the platter.
- 3) As soon as the stylus reaches lead-out groove, turntable spindle gears into main-gear so that the main-gear starts rotating.
- 4) When the main gear starts rotating, the Auto-lever will be pushed outward by see-saw lever located under Return cam. Therefore, the tonearm will automatically return to arm rest.
- 5) While playing a disk, tonearm lifter keeps down gradually because the tip end of see-saw lever moves down in sloped concave A (See Fig. 2-1) on the backside of main gear. On the other hand, when the tonearm is on its rest, the lifter keeps up completely (6~12mm: space between record and stylus) because the tip end of see-saw lever is on the most shallow concave B.

Fig. 2-1

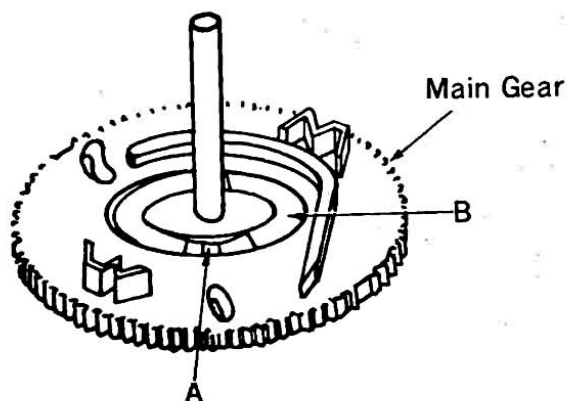
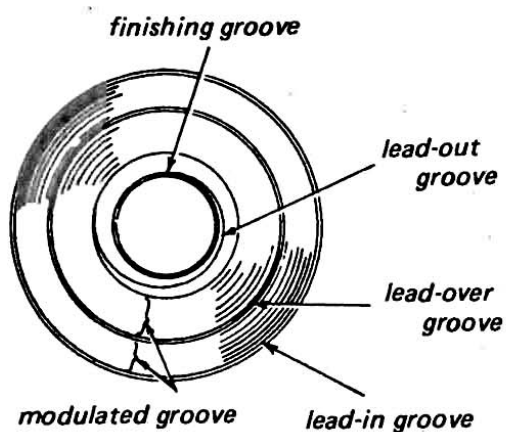

Fig. 2-2



3. ADJUSTMENTS

3-1. Adjusting the Auto Return

- 1) The adjusting screw in Fig. 3-1 is one to adjust the position of Auto Return when stylus reaches lead-out groove.
- 2) Make adjustment of the screw in such a way that stylus lifts up automatically around the middle way of lead-out groove. Namely turn the adjusting screw clockwise is for leading and counterclockwise is for lagging.
- 3) After adjusting the screw properly, check its operation a few times.
*Apply the locking paint in place to the screw after adjustment.

Fig. 3-1

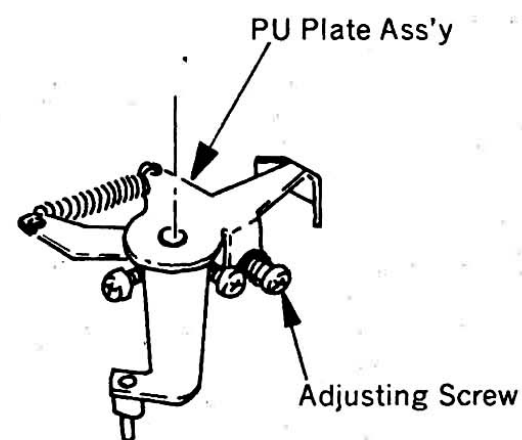

3-2. Adjusting the Height of Tonearm Lifter

- 1) The adjusting screw in Fig. 3-2 is one to adjust the height of tonearm lifter.
- 2) Place a disk (record) on turntable, then switch the tonearm lifter lever to PLAY. If stylus does not come down completely on a disk, turn the screw counterclockwise.
- 3) When tracing, switch tonearm lifter lever to LIFT. If the stylus does not lift up completely from a disk, turn the screw clockwise.
- 4) After adjustment of it, check its operation a few times.
*Apply the locking paint in place to the screw after adjustment.

Fig. 3-2

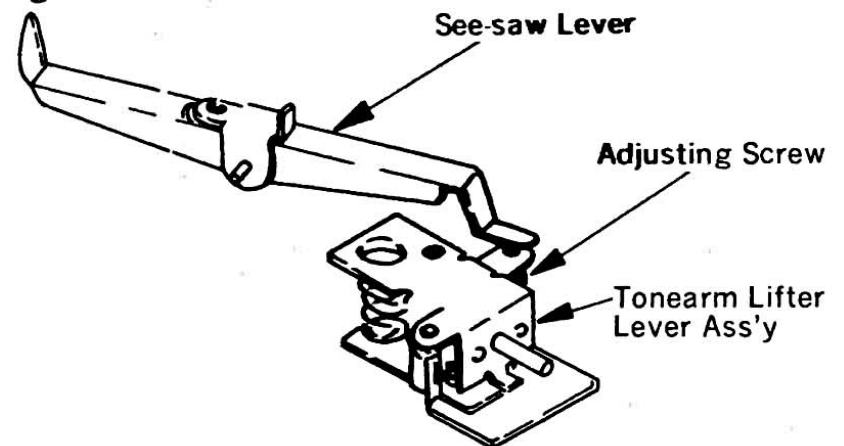

4. PACKING LIST

Parts No.	Stock No.	Description
1	9012250	Inner Packing
2	{ 5502112	Turntable Rubber Mat
	{ 5392050	Turntable Ring
3	{ 6112150	Turntable (Platter)
	{ 6032160	Belt
		Vynil Cover
4	9022560	Stylofoam Packing
5	7012100	Dust Cover Ass'y
		Poryethylene Cover
6	9022550	Stylofoam Packing
	9112150	Vynil Cover
7	9002530	Carton Case
	5996080	Curl Stopper

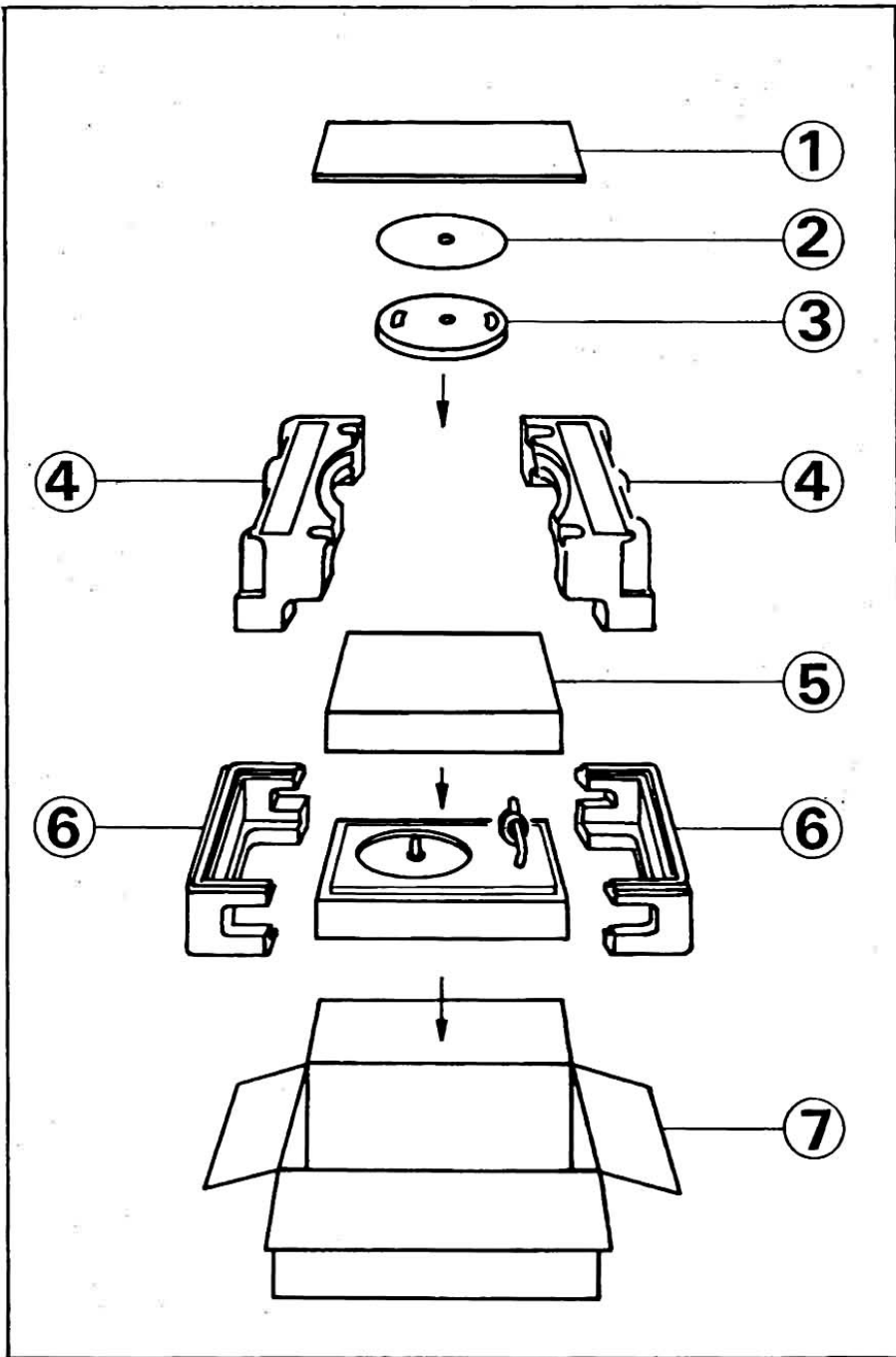

5. ACCESSORY PARTS LIST

* In Parts List below, there are three types A, B & C in same parts No.

When ordering parts, please refer to Notice on Page 1.

Parts No.	Stock No.	Description	
1	{	Head Shell Ass'y	
		Not Included in Type B, C	
		6642200	Head Shell
			Not Included in Type A
		4310220	Cartridge (SC-37)
			Not Included in Type B, C
		4940110	Stylus (SN-37)
			Not Included in Type B, C
			Stylus Cover
			Not Included in Type B, C
2	9432010	Oil Feeder	
3	6172060	45 r.p.m. Adaptor	
4	6912460	I·F·C Weight	
5	{ 6142310	Capstan (50Hz)	
	or	or	
	{ 6142320	Capstan (60HZ)	
		Not Included in Type B	
6	6912300	Main Weight	
	3810260	PU Output Cord	
	3890010	Earth Cord	
	9202370	Operating Instructions	

6. PARTS LOCATIONS & PARTS LISTS

Parts List

* When necessary, order whole assembly (Ass'y) to us since some parts without Stock No. in Parts List below will be not supplied.

Parts No.	Stock No.	Description
1	7012100	Dust Cover Ass'y
	{ 6922270	Lock Plate
	{ 5104263	O Type Screw, M4×10
2	5502112	Rubber Mat, turntable
3	6112150	Turntable (Platter)
4	5392050	Turntable Ring
5	6032160	Belt
13	5103044	P Type Screw, M3×8
14	7092460	Toneram Ass'y
	{ 6912300	Main Weight
	{ 6912460	I.F.C Weight I.F.C Bar
15	5100201	B Type Screw, M2×3
16	5252170	I.F.C Stand
17	7092450	Tonearm Base Ass'y
	{ 7082220	Tonearm Guide
	{ 5105521	SS Type Screw, M2.6×4 (For Tonearm Guide)
	{ 5105563	SS Type Screw, M4×8 (For Tonearm Base)
		Shaft, tonearm lifter Spring, tonearm lifter P Type Washer, 4φ (For Tonearm Lifter)
18	5372100	Knob, lifter cam
19	6012220	Cam, tonearm lifter
20	5103542	PT Type Screw, M3×8
21	7052370	Lifter Lever Ass'y
22	5103542	PT Type Screw, M3×8
23	7052361	Lever, see-saw
25	5110241	Hex. Nut, M3
26	5121240	S Type Washer, 3φ
27	6622170	Arm Rest Ass'y
28	5103542	PT Type Screw, M3×8
30	6322010	Steel Ball
31	5151003	E Type Washer, 2.3φ
33	6502720	Auto Lever
34	7062191	PU Plate Ass'y
35	6902820	Spring, gear stopper
36	5151004	E Type Washer, 3φ
37	6402010	Gear Stopper
39	5151003	E Type Washer, 2.3φ
40	6422010	Auto-Clutch
41	6422030	Auto Trip
42	5151003	E Type Washer, 3φ
43	6422020	Manual Clutch
44	5103044	P Type Screw, M3×8
45	6012280	Cam, return
46	6002020	Main Gear
47	7042080	Spindle Ass'y, turntable
		Shaft, turntable spindle
		Hex. Nut, M9
		P Type Washer, 9φ
	{ 5103041	P Type Screw, M3×4
		Steel Ball
		Bearing, turntable spindle

* In Parts List below, there are three types A, B & C in same parts No.

When ordering parts, please refer to Notice on page 1.

Parts No.	Stock No.	Description	
48	5151004	E Type Washer, 3φ	
49	7052350	Lever, reject	
50	{ 5103542	PT Type Screw, M3×8 (Type A, C)	
		Not Included in Type B	
51	{	Lock Bracket, voltage selector	
		or (Type A,C)	
		Screen, voltage selector (Type B)	
58	5302150	Control Base	
59	6012270	Cam, selector	
60	5302140	Selector Base	
61	6012290	Cam, cuing	
63	6902830	Spring, reject	
67	6902850	Linkage Wire, reject	
69	5103523	PT Type Screw, M2.6×10	
71	7501640	Power Circuit Board Ass'y (Type A,C)	
	{ 0609002	Mylar Capacitor 0.047μF 1000V	
	{ 1120060	See-saw Switch	
	{ 0114479	Solid Resistor 4.7Ω ½W	
71	7501630	Power Circuit Board Ass'y (Type B)	
	{ 0609003	Mylar Capacitor 0.1μF 125V	
	{ 0114689	Solid Resistor 6.8Ω ½W	
74	{	Terminal Pin	
		SS Type Screw, M3×5	
75	{	Capstan (50Hz)	
		or	
		or	
		Capstan (60Hz)	
76	5151005	E Type Washer, 4φ	
77	5502620	Rubber Cushion	
78	5262220	Cushion Holder	
79	5151005	E Type Washer, 4φ	
81	5262220	Cushion Holder	
82	5151005	E Type Washer, 4φ	
83	5502620	Rubber Cushion	
84	5262220	Cushion Holder	
90	{ 4320410	Motor (Type A, C)	
	{ 4320420	Motor (Type B)	
93	6902800	Cushion Spring C	
94	6902790	Cushion Spring B	
95	6902940	Cushion Spring A	
96	6502940	Cushion Spring A	
97	5103525	PT Type Screw, M3×16	
99	1160190	Micro Switch	
107	5140826	RH Type Screw, M3.1×13	
108	3910580	Cord Stopper	
109	{ 3800350	Power Cord (Type A, C)	
	{ 3800360	Power Cord (Type B)	
		Output Cord	
111	3810260	Output Cord	
112	5140826	RH Type Screw, M3.1×13	
113	2200430	Terminal Board Ass'y	
127	{	7172130	Cabinet Ass'y
		5512140	Insulator
		5332041	Sansui Badge
		6922260	Auto Hinge

- 1. Pan Head Tapping Screw PT Type
- 2. Washer Head Tapping Screw WT Type
- 3. Pan Head Screw P Type
- 4. Pan Head SEMS A Screw PSA Type
- 5. Pan Head SEMS B Screw PSB Type
- 6. Blinding Head SEMS F Screw BSF Type
- 7. Blinding Head Screw B Type
- 8. Flat Countersunk Head Screw F Type
- 9. Flat Countersunk Wood Screw FC Type
- 10. Round Head Wood Screw RH Type
- 11. Hex. Socket Setscrew SC Type
- 12. Slot Type Setscrew SS Type
- 13. Spring Washer S Type
- 14. Plain Washer P Type
- 15. Retaining Ring (E Washers) E Type

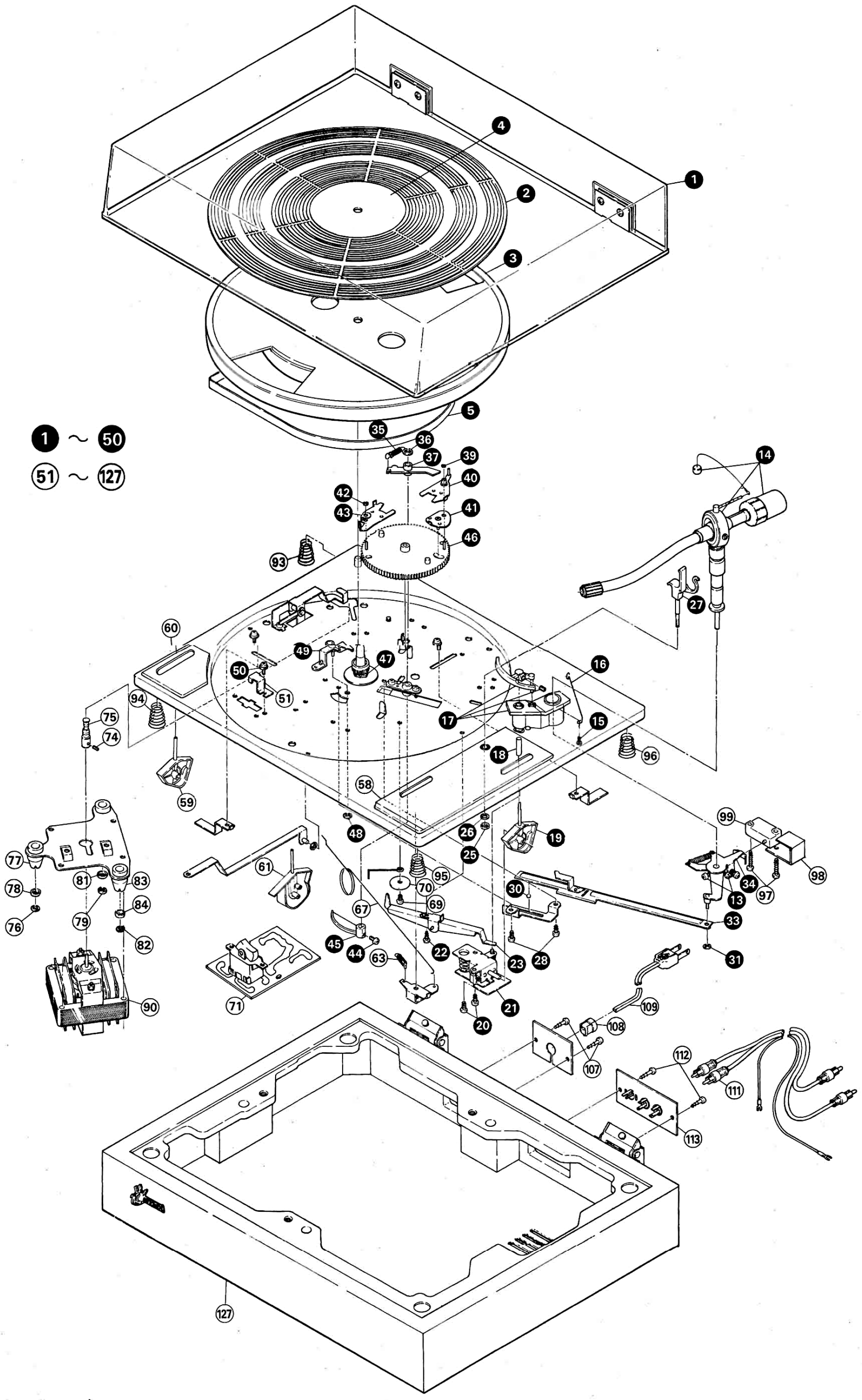

1 ~ 50
51 ~ 127



SANSUI ELECTRIC CO., LTD.
14-1, 2-chome, Izumi, Suginamiku, Tokyo 168, Japan.
TELEPHONE: (03) 323-1111 / TELEX: 232-2076

SM058

Printed in Japan (36720M)