

# SERVICE MANUAL

COMPUTERIZED FULL AUTOMATIC  
DIRECT-DRIVE TURNTABLE

## SANSUI FR-D4

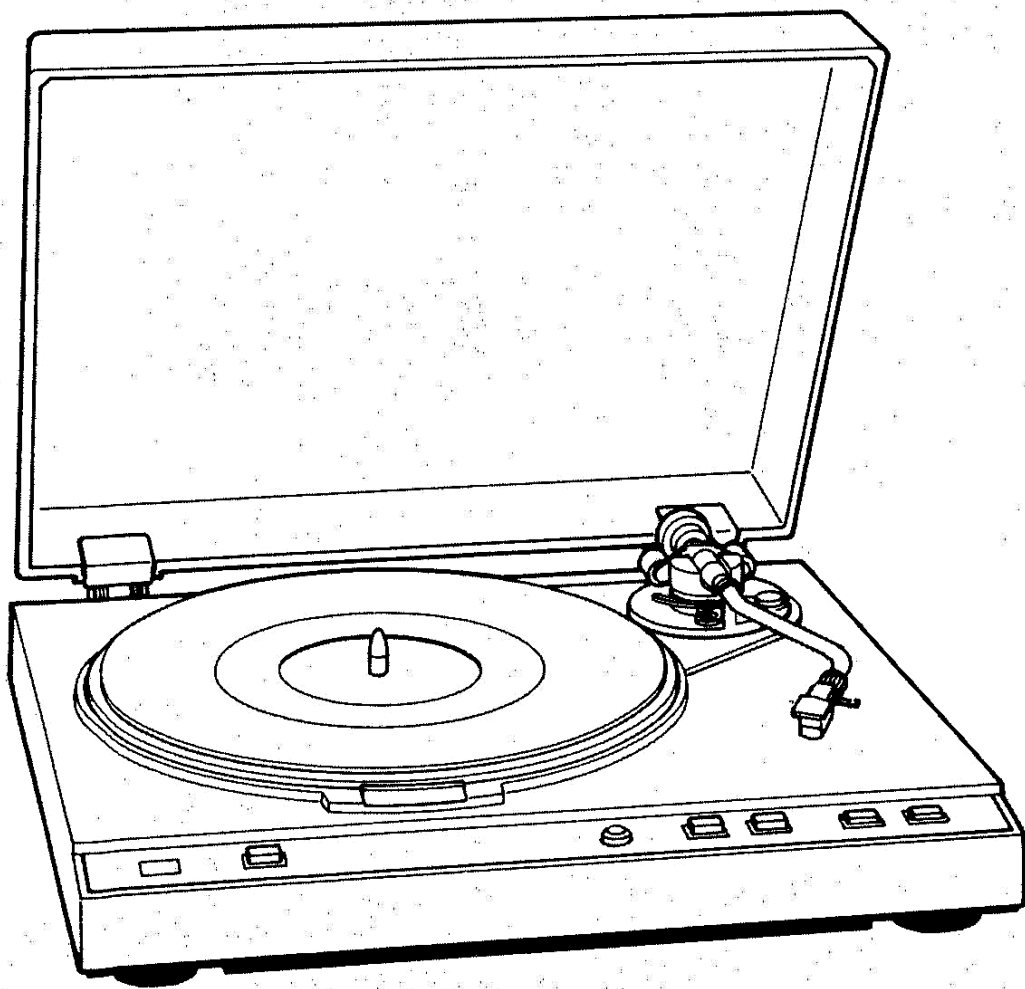

### SPECIFICATIONS

Type	Two-speed direct-driven
Speeds	33-1/3, 45 rpm
Fine speed adjustment range	±3 %
Platter	Aluminium alloy die-cast 300 mm (11-13/16") diameter, 1.1 kg (2.42 lbs.)
Motor	Brushless DC servo-type
Wow and flutter	Less than 0.028 % (WRMS)
S/N	Better than 60 dB (IEC-B)
Rumble	Better than 72 dB (DIN-B)
Tonearm	Statically-balanced S-shaped tubular type
Tonearm length	220 mm (8-11/16")
Overhang	17.5 mm (3/4")
Optimum cartridge weight	When the headshell supplied is employed 4 ~ 10 g
Dimensions	440 mm (17-11/32") W 133 mm (5-1/4") H 385 mm (15-5/32") D
Weight	6.3 kg (13.9 lbs.) net 7.5 kg (16.5 lbs.) packed
Power consumption	9 W (rated)

\*The power voltage is adjusted to the one of the area where you bought the unit.

Specifications of the cartridge (applicable only to the units with cartridge)

#### Model SC-50

Type	Induced magnet
Frequency response	10 ~ 20,000 Hz
Output voltage	3 mV per channel (1,000 Hz, 35.4 mm/sec)
Load impedance	47 kΩ
Tracking force	2.5 g
Stylus	0.6 mil, diamond spherical (SN-50)

\*Design and specifications subject to change without notice for improvements.

*Sansui*

SANSUI ELECTRIC CO., LTD.

## 1. BLOCK DIAGRAM

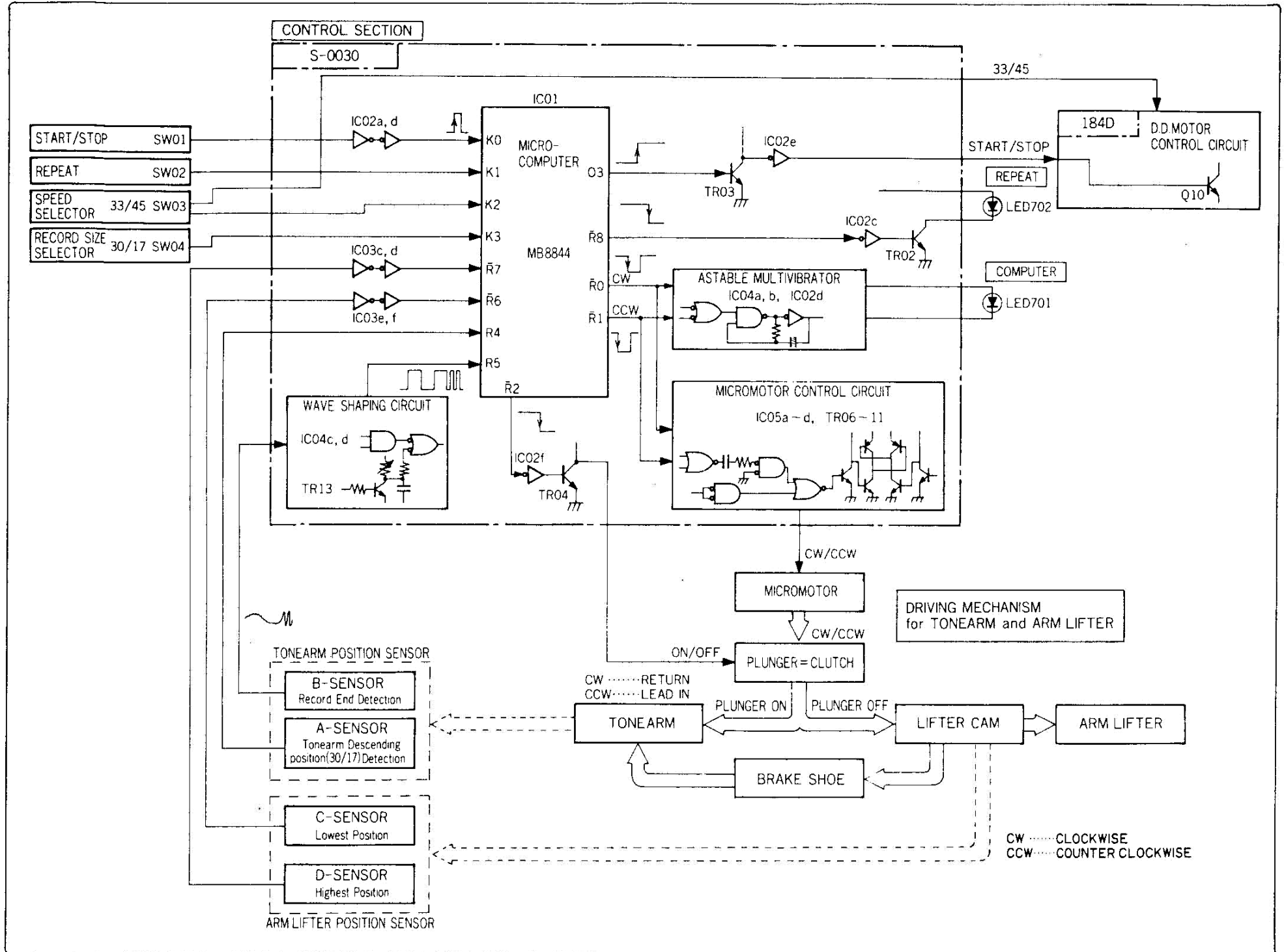

## 2. OPERATION

### 2-1. Construction of Full-Auto System (See Block Diagram)

The full-auto system adopted in this model is composed of 1) Driving mechanism Ass'y for tonearm and arm lifter (here after called driving mechanism ass'y), 2) Electrical control section governing the driving mechanism ass'y.

Arm position sensor (A-sensor, B-sensor) and lifter position sensor (C-sensor, D-sensor) are attached to the driving mechanism ass'y and detecting vertical and horizontal position of tonearm. The control section composed of one chip micro computer (MB8844) and peripheral circuits controls 1) rotation of DD Motor 2) lead-in, return and repeat of tonearm function 3) up or down of lifter operation corresponding to the states of arm position sensor, lifter position sensor and operating switch.

### 2-2. Movement of driving mechanism ass'y and function of arm position sensor, lifter position sensor.

#### 1. Movement of driving mechanism ass'y (See Fig. 2-1, 2-2)

The configuration and side view of driving mechanism ass'y and gear train from micro motor are indicated in Figs. 2-1, 2-2.

The torque of micro motor to drive tonearm and arm lifter is propagated from worm gear Ass'y ⇒ gear (1) ⇒ gear (3) ⇒ friction pulley ⇒ friction disc ⇒ plunger ⇒ clutch plate that clutch plate starts rotation. Since clutch plate and friction disc are fixed to plunger, rotation of friction disc is directly transmitted to clutch plate. Clutch plate is depressed to the gear (2) while plunger solenoid being OFF, however, when it becomes ON, the clutch plate is released from gear (2) then depressed to TA drum. Therefore while plunger solenoid being ON tonearm is driven, and it being OFF arm lifter and brake shoe are operated to transmit the micro motor torque from clutch plate ⇒ gear (2) ⇒ lifter cam.

As brake shoe is depressed to TA drum while arm lifter being arised, tonearm is restricted not to move excessively by its inertia during return and lead-in operation. When the lifter is completely lowered, brake shoe is released from TA drum that tonearm is free from the brake.

2. Function of arm position sensor and lifter position sensor (See Fig. 2-1, 2-2, 2-3)

- The arm position (whether it is ① on the arm rest ② left from arm rest ③ at lead-in position ④ at end position of disc) is detected by arm position sensors called A sensor and B sensor composed of LED and photo-transistor. As shown in Fig. 2-2, LED and photo-transistor are installed on the upper and lower sides of sensor mounting board that the light beam from LED to photo-transistor is shut off or passed through, since screen plate connected to tonearm shaft passes through the space between LED and photo-transistor to cross the light beam. (See Fig. 2-3 A)
  - When tonearm is is; ① on the arm rest, photo-transistors of A, B sensors are ON to be lightened by LED, ② left from arm rest, photo-transistors of A, B sensors turn OFF since the light beam from LED is intercepted by screen plate, ③ at lead-in position of 17 cm or 30 cm disc, only the photo-transistor of A sensor becomes ON to be lightened from slit A or B shown in Fig. 2-3, ④ about to reach lead-out groove, photo-transistor of B sensor continues turning ON and OFF to be lightened from slit C.
- When stylus reaches lead-out groove to finish record playing, the term of turning ON and OFF of B sensor becomes less than 1.3 sec. (33-1/3 rpm) or less than 1.0 sec. (45 rpm). (See Fig. 2-3 B)
- The detection of arm lifter completely up position or down position is performed by C sensor and D sensor, the micro switches. The buttons of these micro switches are depressed by the side surface of lifter cam, however, when the arm lifter is completely risen, the notch on the side surface of lifter cam becomes the position where micro switch button of D sensor is located that the button is released. When arm lifter is completely lowered, the button of C sensor is released by the notch on the lifter cam. (See Fig. 2-2)

Fig. 2-1 Configuration of Mechanism Ass'y

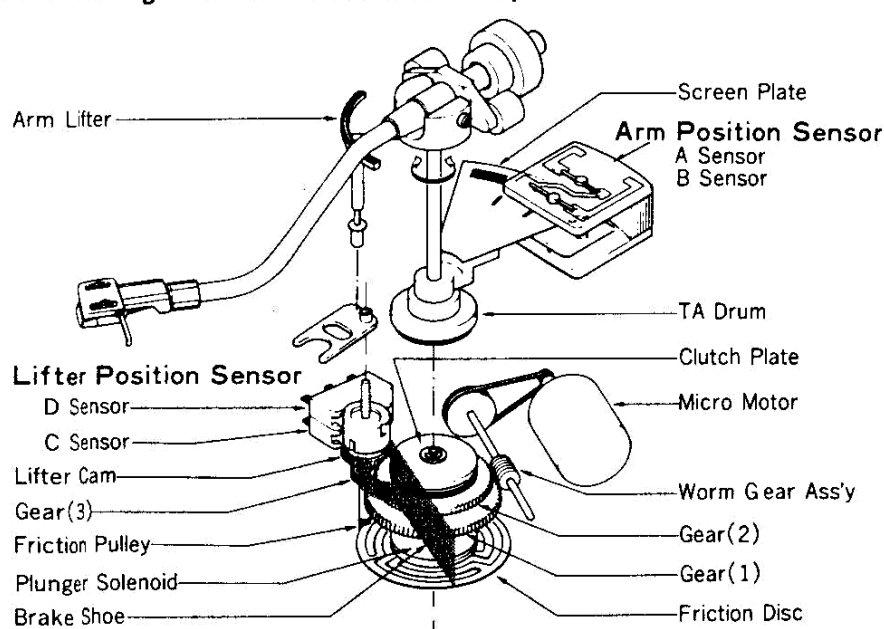
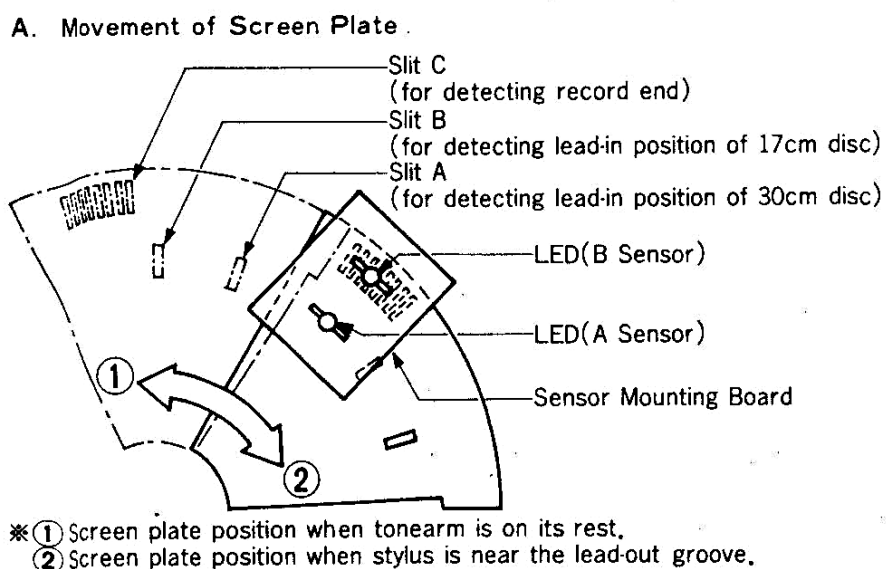

Fig. 2-3 Movement of Screen Plate and Principal of Arm Position Detection



2-3. Control Section and Operation of Micro Computer (See Block Diagram)

- The outputs of A ~ D sensor corresponding to the state of tonearm are applied to input ports  $R_4 \sim \bar{R}_7$  of micro computer/MB8844 as H level (5 V) or L level (0 V) and input ports  $K_0 \sim K_3$  are determined H or L by operation switches ( $SW_{01} \sim SW_{04}$ ). Micro Computer is determined its operation by the states of its input ports, then outputs control signals H or L from output ports ( $\bar{R}_0 \sim \bar{R}_2, \bar{R}_8, O_3$ ).
- Output port  $O_3$  is for the control of DD Motor "start" or "stop" and the port being H, DD Motor rotates. Output port  $\bar{R}_2$  controls plunger solenoid ON and OFF, and plunger solenoid is turned ON so as to depress clutch to TA drum while the port  $\bar{R}_2$  being L. Output ports  $\bar{R}_0, \bar{R}_1$  are for the micro motor control and normally the ports are in H state. When  $\bar{R}_0$  turns to L, micro motor rotates clockwise (CW) and  $\bar{R}_1$  to L, counterclockwise (CCW) rotation. If either of  $\bar{R}_0$  or  $\bar{R}_1$  becomes L state, LED 701 (COMPUTER) starts flickering to operate astable multivibrator. The clockwise rotation of micro motor is corresponding to the return of tonearm, up or down of lifter, and counterclockwise rotation to lead-in of tonearm.
- The input ports  $R_4$  and  $R_5$  of MB8844 receive signals from B sensor through wave shaping circuit and A sensor respectively. When tonearm is; ① on the arm rest,  $R_4$  and  $R_5$  are both in H state, ② left from arm rest,  $R_4$  and  $R_5$  are L state, ③ reaching lead-in position of 30 cm or 17 cm disc,  $R_4$  is H and  $R_5$  is L, ④ reaching lead-out groove,  $R_4$  is L and  $R_5$  receives voltages H or L in the terms of less than 1.3 sec. (33 rpm) or less than 1.0 sec. (45 rpm).

Fig. 2-2 Side View of Mechanism Ass'y and Movement of Gear Train

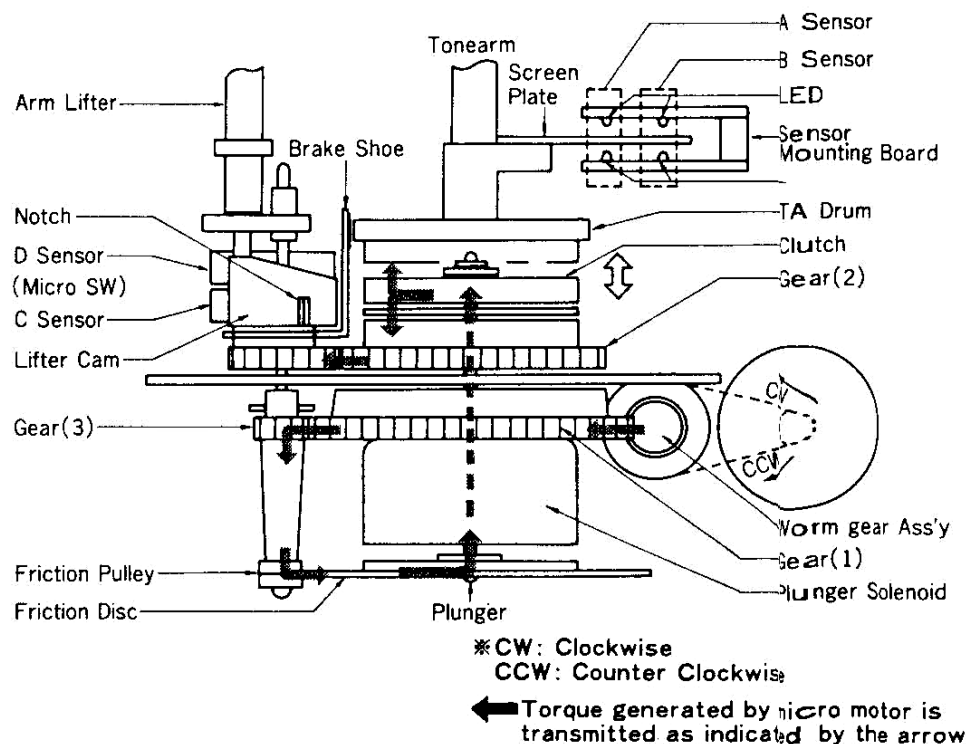

B. Arm Position Detection

States of Photo-Transistors on A, B Sensor

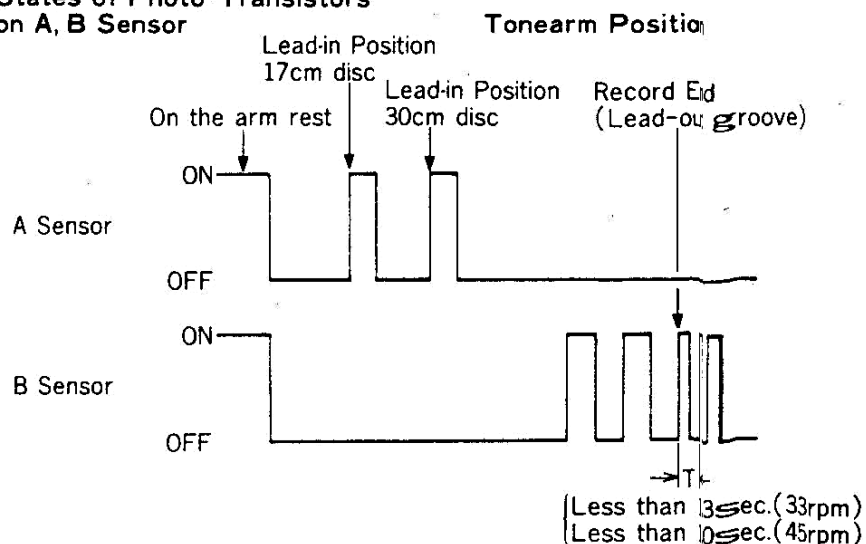
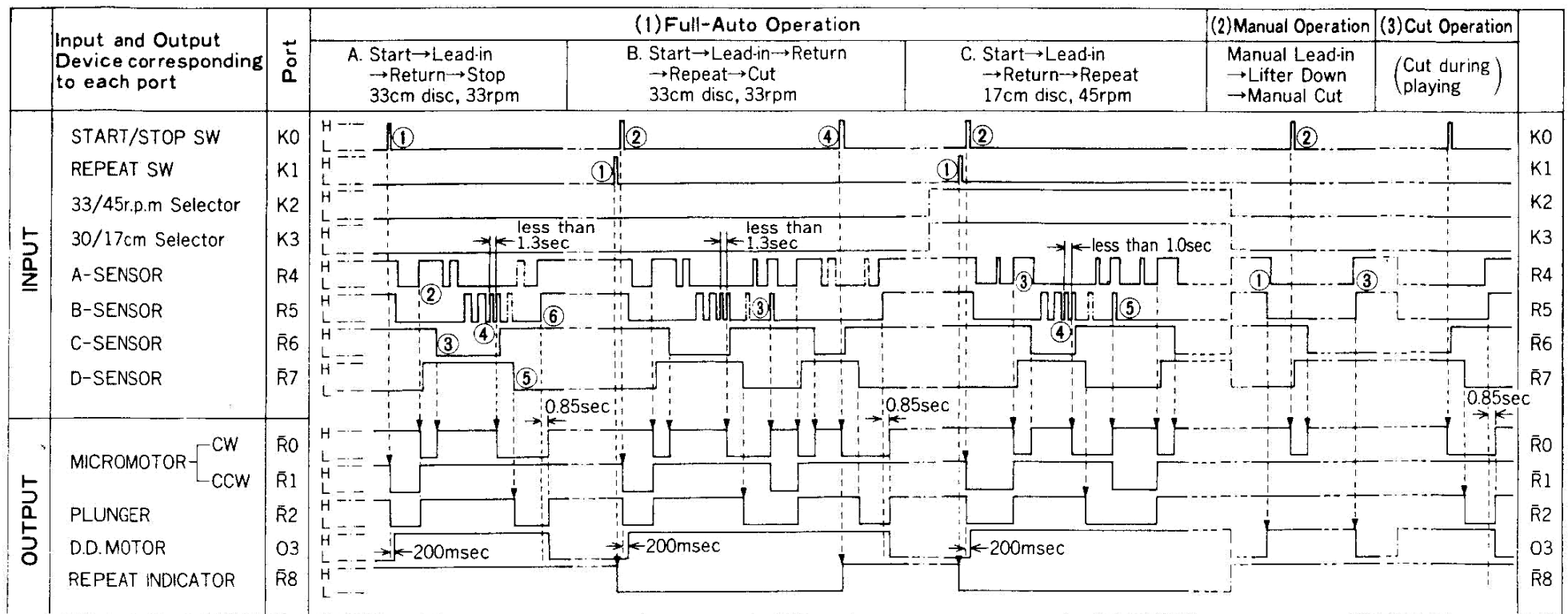

Fig. 2-4 Timing Chart on Input and Output of Micro Computer



## 2-4. The practical Operation of Turntable and Timing Chart of Micro Computer MB8844 (See Fig. 2-4)

### 1. Full-Auto Operation

#### A. Start ⇒ Lead-in ⇒ Return ⇒ Stop in case of 30 cm disc, 33 rpm.

- When input port K<sub>0</sub> of MB8844 turns to H from L to push START/STOP switch, output port R<sub>1</sub> becomes L (which makes micro motor rotate counterclockwise), output port R<sub>2</sub> becomes L (plunger solenoid is ON), that tonearm starts moving in lead-in direction. 200 msec after K<sub>0</sub> becomes H from L, output port O<sub>3</sub> turns to H from L to start DD Motor rotating. As soon as tonearm moves lead-in direction, input ports R<sub>4</sub>, R<sub>5</sub> become L since the light beam from LED is intercepted by the screen plate in A, B sensor.
- When tonearm reaches lead-in position over the 30 cm disc, light passing through slit A (Fig. 2-3) makes photo-transistor of A sensor ON, thus input port R<sub>4</sub> of MB8844 becomes H from L. Sequently to the R<sub>4</sub> from L to H, R<sub>2</sub> turns to H from L (plunger solenoid is OFF), R<sub>1</sub> becomes H from L, R<sub>0</sub> becomes L from H (micro motor rotates counterclockwise) that the torque of micro motor is transmitted to the lifter cam which lowers arm lifter. Following to the rotation of lifter cam, the button of D sensor is depressed by the lifter cam and R<sub>7</sub> becomes H state.
- After arm lifter is completely lowered to rotate lifter cam, the button of C sensor is released to enter into the notch of lifter cam. Therefore input port R<sub>6</sub> of MB8844 becomes L from H and R<sub>0</sub> becomes H from L that rotation of micro motor is stopped.
- When stylus of cartridge proceeds till 62 mm from center of disc, the photo-transistor of B sensor repeats turning ON and OFF alternately that voltage level H and L is alternately applied to input port R<sub>5</sub> of MB8844. After stylus enters to lead-out groove, the applied voltage to R<sub>5</sub> repeats H, L in the term less than 1.3 sec, which is detected as the end of record disc that output port R<sub>0</sub> turns to L from H (micro motor starts counterclockwise rotation) and arm lifter is arised.
- With the complete rise of arm lifter, input port R<sub>7</sub> becomes L from H to be released the button of D sensor. Sequently to the R<sub>7</sub> from H to L, R<sub>2</sub> turns to L from H (plunger solenoid turns ON) that clutch plate is depressed to TA drum, and tonearm moves return direction.
- When tonearm is reached arm rest, photo-transistors of A, B sensors are lightened that they turn on, which makes input

ports R<sub>4</sub>, R<sub>5</sub> of MB8844 turn to H. 0.85 sec after this, R<sub>0</sub> becomes H from L (micro motor stops), R<sub>2</sub> is H from L (plunger solenoid turns OFF), and O<sub>3</sub> becomes L from H (DD Motor stops).

#### B. Start ⇒ Lead-in ⇒ Repeat ⇒ Cut in case of 30 cm disc, 33 rpm.

- When Repeat switch is pushed at once, the input port K<sub>1</sub> of MB8844 turns to H from L, and output port R<sub>8</sub> to L from H (repeat indicator LED 702 becomes luminous).
- If START/STOP switch is pushed followingly to the above, tonearm moves as the same process with A-1) ~ 6) and returns to its rest after finishing record playing.
- When tonearm reaches just before arm rest, photo-transistors of A, B sensors turn ON, which causes output port R<sub>0</sub> to change to H from L (clockwise rotation of micro motor is stopped) and R<sub>1</sub> to be L from H (micro motor rotates counterclockwise) that lead-in operation is performed.
- Since output port R<sub>0</sub> of MB8844 becomes L from H (micro motor starts clockwise rotation) to push the START/STOP switch once more, arm lifter is arised immediately. At this time the repeat function is released that output port R<sub>8</sub> becomes H from L and repeat indicator stops lighting.
- The following operation is carried out in the same manner of A.5), 6), and tonearm returns to arm rest.

#### C. Start ⇒ Lead-in ⇒ Return ⇒ Repeat in case of 17 cm disc, 45 rpm.

- When repeat switch is pushed, input port K<sub>1</sub> of MB8844 turns to H from L instantaneously with R<sub>8</sub> from H to L. (repeat indicator starts lighting)
- Tonearm moves as the same process as A-1) after START/STOP switch is pushed.
- MB8844 detects whether tonearm reaches lead-in position of 17 cm disc by the second rise up signal (L → H) applied to input port R<sub>4</sub> and makes output ports R<sub>0</sub> from H to L, R<sub>1</sub> from L to H and R<sub>2</sub> from L to H to lower the arm lifter.
- When stylus reaches lead-out groove, signals H and L are alternately applied to input port R<sub>5</sub> as a record end signal in the term less than 1.0 sec. After detecting record end, tonearm returns in the same manner of A-4), 5).
- When tonearm reaches just before arm rest to turn ON photo-transistors of A, B sensor, both inputs R<sub>4</sub>, R<sub>5</sub> of MB8844 become H that output port R<sub>0</sub> turns to H from L, R<sub>1</sub> to L from H (micro motor starts counterclockwise rotation) and lead-in function is performed again.

Input and Output Device corresponding to each port	Port	(4) Protection Program	
		A. Protection of Plunger solenoid & Motors (In case that tonearm is clamped on its rest.)	B. Emergency Stop (In case that tonearm is on the way of returning.)
START/STOP SW	K0	H	H
REPEAT SW	K1	H	H
33/45r.p.m Selector	K2	H	H
30/17cm Selector	K3	H	H
A-SENSOR	R4	H	H
B-SENSOR	R5	H	H
C-SENSOR	R6	H	H
D-SENSOR	R7	H	H
MICROMOTOR—CW	R0	H	H
PLUNGER	R1	H	H
D.D.MOTOR	O3	H	H
REPEAT INDICATOR	R8	H	H

**2. Manual Operation**

- When tonearm is moved from arm rest, photo-transistors of A, B sensors turn OFF, which causes input port R<sub>4</sub>, R<sub>5</sub> of MB8844 to be L. At this time output port O<sub>3</sub> of MB8844 turns to H from L that DD Motor starts rotating.
- When pushing START/STOP switch after placing tonearm to desired position, arm lifter is lowered since output port R<sub>0</sub> becomes L from H.
- The same function as A-4) ~ 6) in full-auto operation is performed after tonearm is lowered, however, if tonearm is returned manually during record playing, photo-transistors of A, B sensors turn ON just before tonearm reaches its rest that input ports R<sub>4</sub>, R<sub>5</sub> of MB8844 become H. At this time, output port O<sub>3</sub> changes to L from H that rotation of DD Motor is stopped.

**3. Cut Operation**

The tonearm returns to its rest immediately during any operation if START/STOP switch is pushed. For instance, if START/STOP switch is pushed during record playing, output port R<sub>0</sub> turns to L from H simultaneously to input port K<sub>0</sub> to H from L that tonearm returns as the same way of A-4) ~ 6) in full-auto operation.

**4. Protection Program**

Two sorts of protection programs are provided with MB8844 for extraordinary operation of the unit.

**A. Protection for Plunger Solenoid and Motors**

- If input ports of MB8844 are not changed their state for 20 sec after START/STOP switch is pushed, output ports R<sub>1</sub> changes to H from L, R<sub>2</sub> to H from L, and O<sub>3</sub> to L from H that micro motor and DD Motor stop their rotation and plunger solenoid turns OFF.
- The protection is released to push START/STOP switch, and one more push of START/STOP switch actuates full-auto operation.

**B. Emergency Stop Operation**

- If input port R<sub>7</sub> turns to H from L (arm lifter is not completely arised) for some reason, while output port R<sub>2</sub> of MB8844 being L (plunger solenoid is ON... tonearm is on the way of traveling), the unit shuts down its operation immediately in order not to damage the disc and the stylus.
- Once the START/STOP switch is pushed, the protection is released.

**2-5. Operation of Micro Computer Periphery Circuits**

**1. Output of A Sensor and B Sensor, and Operation of Wave Shaping Circuit (See Figs. 2-5, 2-6)**

The position of tonearm and end of record disc are detected by A sensor and B sensor. Output of A sensor is applied to input port R<sub>4</sub> of MB8844 through IC<sub>03a</sub> and IC<sub>03b</sub>, inverters. Output of B sensor is fed to R<sub>5</sub> through wave shaping circuit composed of TR<sub>13</sub>, IC<sub>04c</sub> and IC<sub>04d</sub>.

**A. When tonearm is placed on arm rest.**

Since the light beam from LED<sub>01</sub> and LED<sub>02</sub> are not intercepted by the screen plate, PT<sub>01</sub> and PT<sub>02</sub> (photo-transistors) in A, B sensors are ON state, therefore input port R<sub>4</sub> of MB8844 and input gates 8, 9 of IC<sub>04c</sub> are H that output gate 10 of IC<sub>04c</sub> becomes L. As input gate 12 of IC<sub>04d</sub> is L, output gate 11 is H. Resultly both input ports R<sub>4</sub>, R<sub>5</sub> are H while tonearm is placed on arm rest.

**B. When tonearm is left from arm rest**

Since the light beam from LED<sub>01</sub> and LED<sub>02</sub> are intercepted by screen plate, PT<sub>01</sub> and PT<sub>02</sub> are OFF state, therefore input port R<sub>4</sub> and input gates 8, 9 of IC<sub>04c</sub> are L, output gate 10 of IC<sub>04c</sub> is H. As output of PT<sub>02</sub> is fed to base of TR<sub>13</sub> through C<sub>04</sub>, the collector voltage of TR<sub>13</sub> is not changed except the period while PT<sub>02</sub> repeating ON and OFF (during detection of record end) that input gate 13 of IC<sub>04d</sub> is H and its output gate 11 is L. Resultly, both input port R<sub>4</sub>, R<sub>5</sub> are L when tonearm is left from arm rest.

Fig. 2-5 Configuration of Wave Shaping Circuit

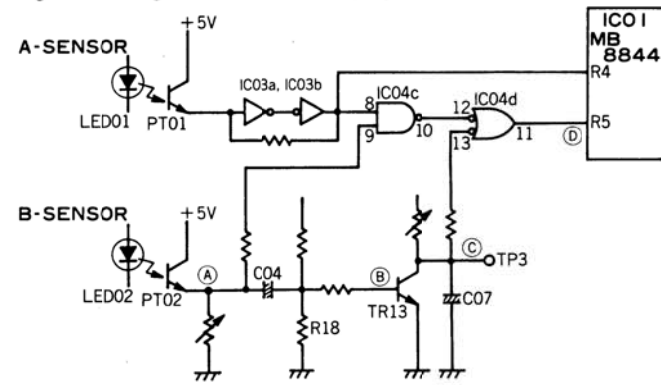
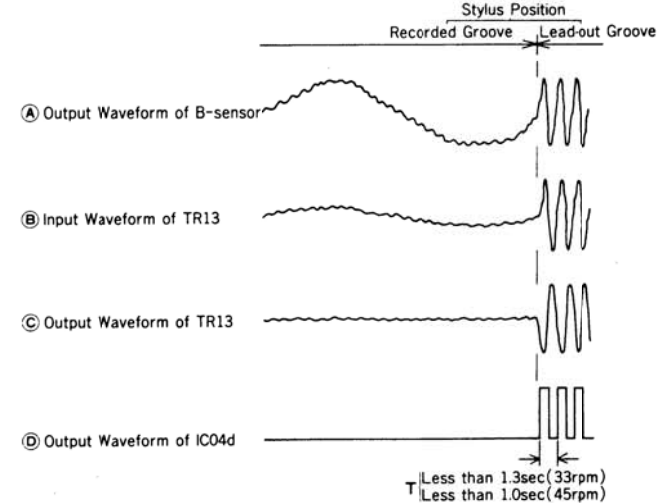

Fig. 2-6



**C. When tonearm is at lead-in position of 30 cm or 17 cm disc.**

Only PT<sub>01</sub> of A sensor turns ON and input port R<sub>4</sub> of MB8844 changes to H from L, and R<sub>5</sub> is kept to be L. By the first rise up signal (L → H) through R<sub>4</sub>, MB8844 detects tonearm reaching lead-in position of 30 cm disc and the second rise up signal (L → H), lead-in position of 17 cm disc.

**D. Detection of record end**

When stylus of cartridge reaches 62 mm before center of platter, PT<sub>02</sub> of B sensor repeats turning ON and OFF to be lightened through slit C (Fig. 2-3) and outputs signal as Fig. 2-6 (A). Output of PT<sub>02</sub> is fed to input gate 13 of IC<sub>04d</sub> through C<sub>04</sub>, TR<sub>13</sub> and although fed to input gate 9 of IC<sub>04c</sub>. At this time, input gate 8 of IC<sub>04c</sub> is L since PT<sub>01</sub> is kept OFF that output gate 10 becomes H regardlessly to the input gate 9. Thus IC<sub>04d</sub> performs as the same function of inverter against the signal applied to input gate 13 with input gate 12 being H. Resultly when the signal with its waveform shown in Fig. 2-6 (C) is applied to input gate 13, the output waveform of gate 11 is the square waveform as shown in Fig. 2-6 (D). The term of this square wave is less than 1.3 sec when 33 rpm and less than 1.0 sec when 45 rpm.

**2. Micro Motor Control Circuit (See Fig. 2-7)**

Micro motor control circuit is not only for driving the micro motor to rotate clockwise or counterclockwise according to the signals from output ports R<sub>0</sub>, R<sub>1</sub> of MB8844 but also for cancelling inertia occurring when its clockwise rotation is stopped. During output ports R<sub>0</sub>, R<sub>1</sub> being H state, the rotation of micro motor is stopped. Clockwise rotation is performed when R<sub>0</sub> is L, and counterclockwise rotation when R<sub>1</sub> is L. The configuration of micro motor control circuit is shown in Fig. 2-7.

**A. Clockwise rotation of micro motor (corresponding to returning of tonearm or elevation of arm lifter)**

The state of IC<sub>05a</sub> ~ IC<sub>05d</sub> in the control circuit are indicated by (H), (L) as Fig. 2-7 while rotation of micro motor is stopped. If R<sub>0</sub> turns to L from H, output gate 3 of IC<sub>05a</sub> becomes H from L, however, input gate 5 of IC<sub>05b</sub> is kept to be H that outputs of IC<sub>05b</sub> and IC<sub>05d</sub> are not changed. Resultly TR<sub>11</sub> is ON and TR<sub>09</sub>, TR<sub>06</sub> are OFF state. On the other hand TR<sub>10</sub> turns OFF with R<sub>0</sub> changing to L from H that TR<sub>08</sub>, TR<sub>07</sub> turn ON. Therefore a current flows successively from TR<sub>07</sub> → micro motor → TR<sub>08</sub> and micro motor starts clockwise rotation.

Fig. 2-7 Configuration of Micro Motor Control Circuit

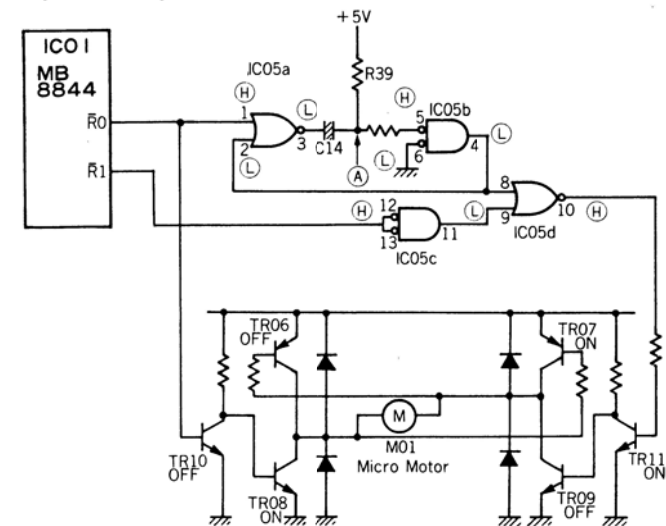

Note: (H) and (L) in this Fig. indicate the voltage level of input and output gates of IC<sub>05a</sub> ~ IC<sub>05d</sub> when the micro motor is stopped. ON, and OFF in Fig. above indicate the state of TR<sub>06</sub> ~ TR<sub>11</sub> when the micro motor rotates clockwise.

**B. Stop operation from clockwise rotation**

When R<sub>0</sub> turns to H from L and micro motor is about to stop from clockwise rotation, the mono-stable multivibrator composed of IC<sub>05a</sub> and IC<sub>05b</sub> is activated to flow a current so as to rotate micro motor counterclockwise for 10 msec that the rotation caused by micro motor inertia is cancelled. While micro motor is rotating clockwise, the inputs gate 1, 2 of IC<sub>05a</sub> are kept L and output gate 3 is H, however, if R<sub>0</sub> turns to H from L, output gate 3 becomes L from H that the voltage at point (A) becomes 0 V instantaneously and outputs of IC<sub>05b</sub>, IC<sub>05d</sub> are inverted. But C<sub>14</sub> is charged through R<sub>39</sub> that voltage at point (A) reaches threshold level of IC<sub>05b</sub> 10 m sec after the voltage at point (A) to be dropped instantaneously, therefore input gate 5 of IC<sub>05b</sub> becomes H and input and output levels of IC<sub>05b</sub>, IC<sub>05d</sub> return to initial state. The period 10 msec, while the voltage at point (A) is lower than the threshold level, output gate 4 of IC<sub>05b</sub> is H, output gate 10 of IC<sub>05d</sub> is L that TR<sub>11</sub> is OFF, TR<sub>09</sub>, TR<sub>06</sub> are ON, which makes a current path of TR<sub>06</sub> → micro motor → TR<sub>09</sub>. Resultly, a counterclockwise torque is generated to the micro motor to cancel the rotation caused by inertia.

**C. Counterclockwise rotation (corresponding to lead-in operation of tonearm)**

Since output port R<sub>0</sub> of MB8844 is kept H and R<sub>1</sub> is L while micro motor rotates counterclockwise, TR<sub>10</sub> is ON, TR<sub>07</sub>, TR<sub>08</sub> are OFF, output gate 11 of IC<sub>05c</sub> is H, output gate 10 of IC<sub>05d</sub> is L, and TR<sub>11</sub> is OFF state. Therefore TR<sub>06</sub>, TR<sub>09</sub> are ON state and a current flows successively from TR<sub>06</sub> → micro motor → TR<sub>09</sub> that micro motor rotates counterclockwise.

**3. Start/Stop Circuit for DD Motor (See Fig. 2-8)**

Start/Stop of DD Motor is controlled by output port O<sub>3</sub> of MB8844, TR<sub>03</sub> and IC<sub>02e</sub> on circuit board S-0030 and switching transistor Q<sub>10</sub> on DD Motor control circuit board 184D. When output port O<sub>3</sub> of MB8844 becomes H, collector voltage of TR<sub>13</sub> is decreased, output of IC<sub>02e</sub>, inverter, is H, and switching transistor Q<sub>10</sub> on circuit board 184D is ON. Therefore, normal bias voltage is applied to the control transistors Q<sub>04</sub> ~ Q<sub>06</sub> on circuit board 184D and DD Motor control circuit is actuated to rotate the DD motor.

Fig. 2-8 Start/Stop Circuit for DD Motor

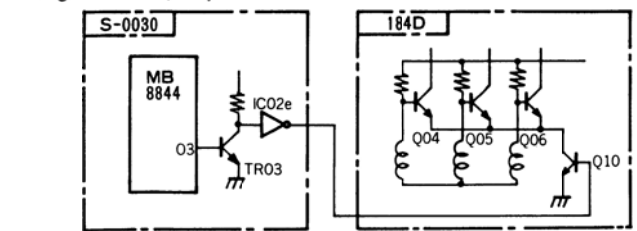

Fig. 2-9 Relation between input and output of NAND gate and NOR gate

NAND	NOR	Input	Output
		HH	L
		HL	H
		LL	H
		HH	L
		HL	L
		LL	H

### 3. PARTS LOCATION & PARTS LIST

#### 3-1. S-0030 Computerized Control Circuit Board (Stock No. 7599101)

Since some of capacitors and resistors are omitted from parts lists in this Service Manual, refer to the Common Parts List for capacitors & resistors which was appended previously to each Sansui Manual.

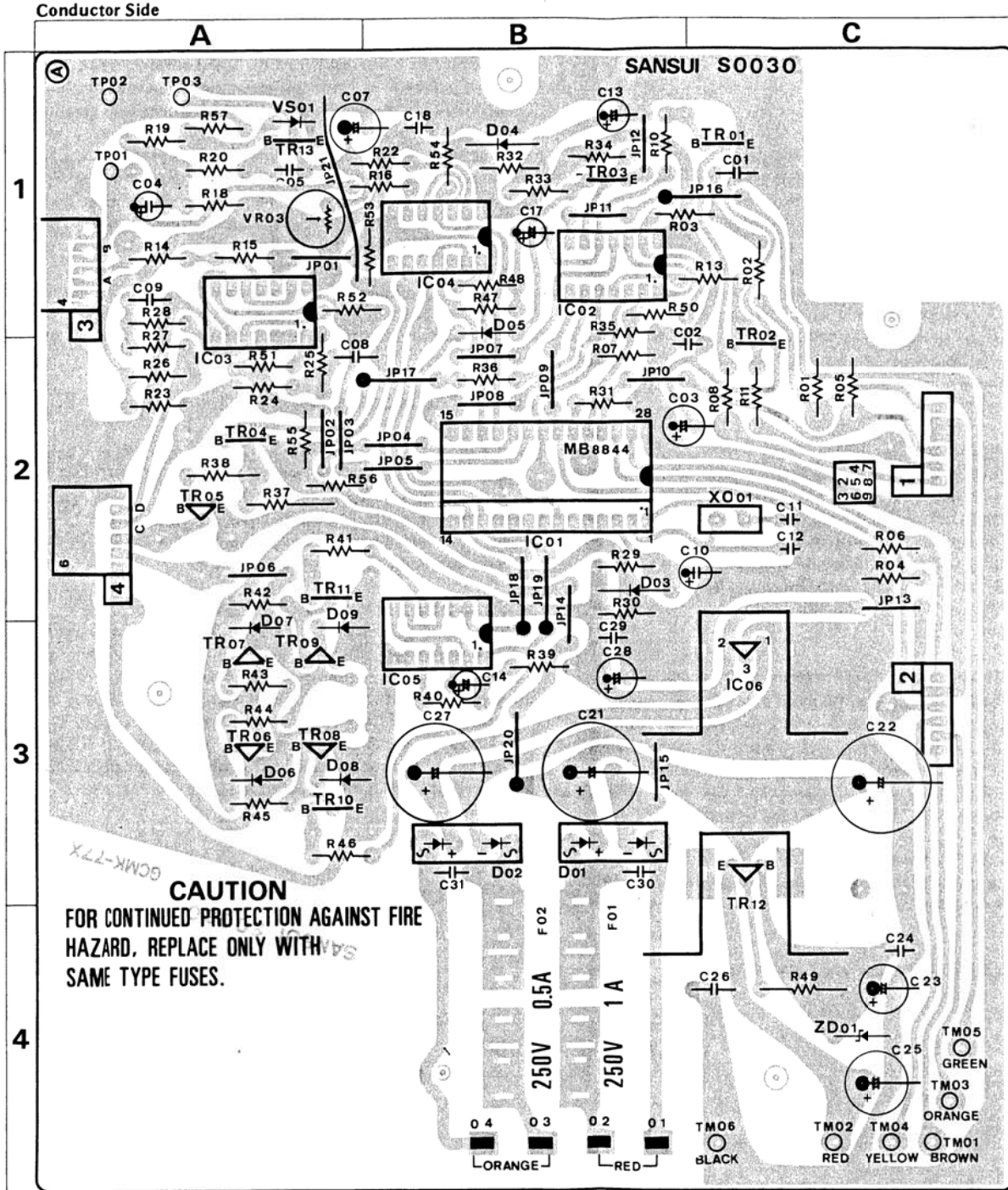

Parts No.	Stock No.	Description	Position	Parts No.	Stock No.	Description	Position	Parts No.	Stock No.	Description	Position				
<b>•Transistor</b>															
TR01 ~ 04	0305951 ~ 3	2SC945 Q, P, K	1B, 1C, 2A, 2C	IC 04	0710690	MSM4011BRU	1B	C 11, 12	0669220	20pF 50V C.T.	2C				
TR05	0303361, 2	2SB560MP E, F	2A	IC 05	0360590	MSM4001RS	3B	VR03	1035140	15kΩ (B) Record end Sensitivity Adj.	1A				
TR06, 07	0301220, 1	2SA934 P, Q	3A	IC 06	0361050	TC4001BP	3C								
TR08, 09	0306910, 1	2SC2060 P, Q	3A	<b>•Diode</b>											
TR10, 11	0305951 ~ 3	2SC945 Q, P, K	3A, 2A	D 01, 02	0311700	RB-152	3B	F 01	0432220	1A 250V AC Fuse (XX, CS)	4B				
TR12	0308391 ~ 3	2SD313AL D, E, F	3C	D 03, 04	0310330	1N60	2B, 1B								
TR13	0305951	2SC945 Q	1A	D 05 ~ 09	0311160	152473D	1B, 3A								
<b>•IC</b>												F 02	0432210	0.5A 250V AC Fuse (XX, CS)	4B
IC 01	0361020	MB8844	2B	VS01	0340120	VD1212	1A								
IC 02, 03	0360570, 0710760	MSM4069, TC4069BP	1B, 1A	<b>•Zener Diode</b>											
IC 04	0360400, 0360410	MSM4011BP, TC4011BP	1B	ZD01	0316020	EQA01-1BR	4C								
								C 04	0573478	0.47μF 35V Ta.C.	1A				
								C 10	0573108	0.1μF 35V Ta.C.	2C				

#### 3-2. 184D DD Motor Control Circuit Board

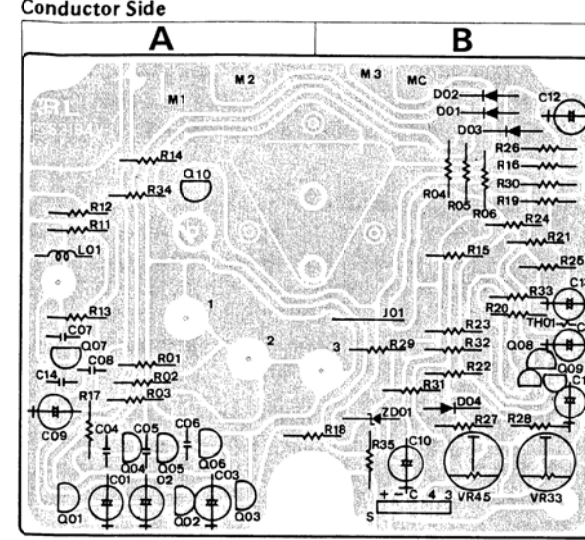

Parts No.	Stock No.	Description	Position
<b>•Transistor</b>			
Q 01 ~ 03	0301221	2SA934 Q	A
Q 04 ~ 08	0305951 ~ 3	2SC945 P, Q, K	A, B
Q 09	0860290, 1	2SA798 F, G	B
Q 10	0305951 ~ 3	2SC945 P, Q, K	B
<b>•Diode</b>			
D 01 ~ 03	0311050	1S953	B
D 04	0311050	1S953	B
ZD01	0316630	RD51EB	B
<b>•Thermistor</b>			
TH01	0320140	SDT-100	B
VR33, 45	1035110	4.7kΩB Speed Adj. Volume	B

**•Note**  
As to C.S.A., B.S., E.S, and xx marked in the Parts Lists, note the followings:  
C.S.A. . . . . Parts used in the unit which is applicable to Canada under industrial standards.  
B.S. . . . . Parts used in the unit which is applicable to British under industrial standards.  
E.U. . . . . Parts used in the unit which is applicable to Sweden, Denmark, Norway, Finland, West Germany, and Switzerland under industrial standards.  
XX . . . . . Parts used in the unit which is applicable to other countries excepting mentioned above.

#### 3-3. S-0028 Power Fuse Circuit Board

Parts No.	Stock No.	Description
C 01	0605337	0.033μF 250V F.C. (M) (XX)
	0598337	0.033μF 250V F.C. (EU, BS)
	0635337	0.033μF 125V F.C. (CS)
R 01	0211123	12kΩ 1W N.I.R. (XX, CS)
	0211333	33kΩ 1W (EU, BS)
F 01	0432210	0.5A 250V AC Fuse (XX, CS)
	0435190	80mA 250V Time Lag Fuse (EU, BS)

#### 3-4. S-0031 Key Switch Circuit Board

Parts No.	Stock No.	Description
LED701	0319250	LED (GREEN), COMPUTER
LED702	0319250	LED (RED), REPEAT
SW01, 02	1190700	Key Switch, START/STOP REPEAT

#### 3-5. S-0032 B Sensor Sensitivity Adjusting Circuit Board

Parts No.	Stock No.	Description
VR02	1035350	4.7kΩ (B) B-sensor Sensitivity Adj.

#### 3-6. S-0033 Push Switch Circuit Board

Parts No.	Stock No.	Description
VR01	1005400	2kΩ (B) Speed Adj.
SW03	1131960	Push Switch, speed selector, record size selector

•Abbreviations	
C.R. . . . . Carbon Resistor	E.L. . . . . Low Leak Electrolytic Capacitor
S.R. . . . . Solid Resistor	E.B. . . . . Bi-Polar Electrolytic Capacitor
Ca.R. . . . . Cement Resistor	E.B.L. . . . . Low Leak Bi-Polar Electrolytic Capacitor
M.R. . . . . Meta Film Resistor	Capacitor
F.R. . . . . Fusig Resistor	Ta.C. . . . . Tantalum Capacitor
N.I.R. . . . . Non-Inflammable Resistor	F.C. . . . . Film Capacitor
C.C. . . . . Ceramic Capacitor	M.P. . . . . Metallized Paper Capacitor
C.T. . . . . Ceramic Capacitor, Temperature Compensation	P.C. . . . . Polystyrene Capacitor
E.C. . . . . Electrolytic Capacitor	G.C. . . . . Gimnic Capacitor

### 4. OTHER PARTS

Parts List <Top View>				Parts List <Bottom View>			
Parts No.	Stock No.	Description	Position	Parts No.	Stock No.	Description	Position
1	6112230	Platter		18	6642360	Head Shell Ass'y	
2	5502960	Rubber Mat		19	7092950	Tonearm Ass'y (without Main Weight, Head Shell)	1
3	5362680	Control Plate		20	6622310	Armrest Fook Ass'y (Fook, Screw)	2
4	1131230	Push Switch, Power		21	7092930	Arm base	3
5	5322180	Push Knob, Power Switch, 33/45 r.p.m. Selector, 30/17 cm Selector		22	6912660	IFC Ass'y (Knob, drum, thread, spring, screw, washer, steel ball)	4
6	5442040	Strobe Cover		23	7082340	Lifter Ass'y (Lifter Plate Ass'y, Lifter Piston Ass'y)	5
7	0410140	Neon Lamp		24	7082360	Main Weight	6
8	1005400	Pitch Control Volume, 2 kΩ (B)		25	6912690	Output Cord	7
9	5312421	Pitch Control Knob		26	5062480	Lid	8
10	1131960	Push Switch Ass'y, 33/45 r.p.m. Selector, 30/17 cm Selector		27	3810340	Output Cord	
11	5422040	Indicator Lens, Computer			3810360	Output Cord	
12	0319260	LED (Green), Computer			3800470, 1	Power Cord (XX, CS)	
13	5422030	LED (Red), Repeat			3800430	Power Cord (BS)	
14	0319250	LED (Red), Repeat			3800450	Power Cord (EU)	
15	1190700	Key Switch, Start/Stop, Repeat		28	6172040	EP Adaptor	
16	7102110	Key Switch Knob Ass'y (Knob, Knob guide, Cushion, Plastic washer, E Type Washer 3.2φ)		29	7012221	Dust Cover Ass'y (Dust Cover, Cushion Rubber)	
17	4310370	Cartridge Ass'y, SC50 (XX) (including 17-1, 17-2)		30-1	5502950	Cushion Rubber	
17-1	4940230	Stylus, SN-50 (XX)		31	6922410	Auto Hinge	
17-2	5192160	Screw Ass'y		32	5392240	Knob Guide, Power Switch, 33/45r.p.m. Selector, 33/17 cm Selector	

4-1. Top View

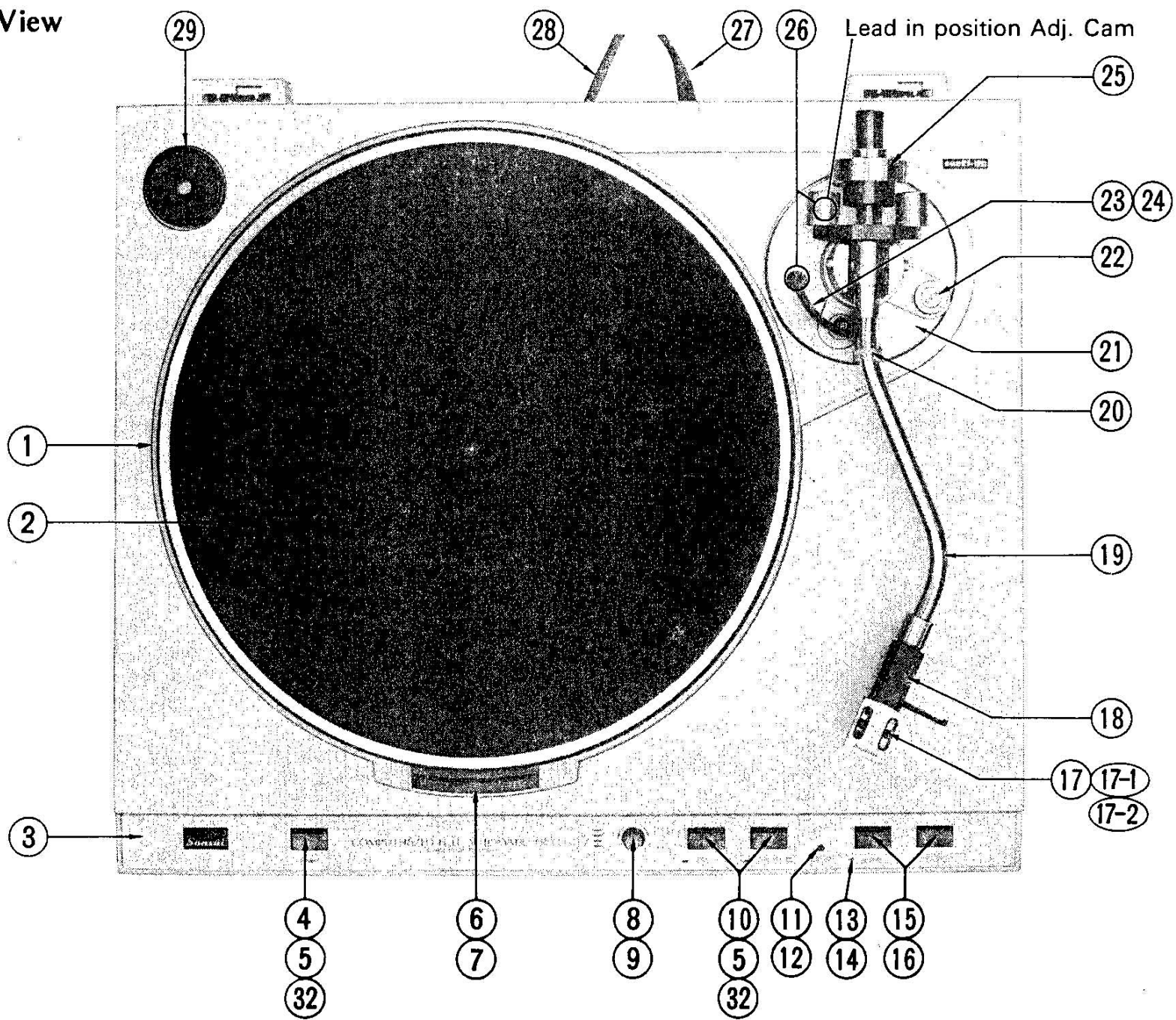

4-2. Bottom View

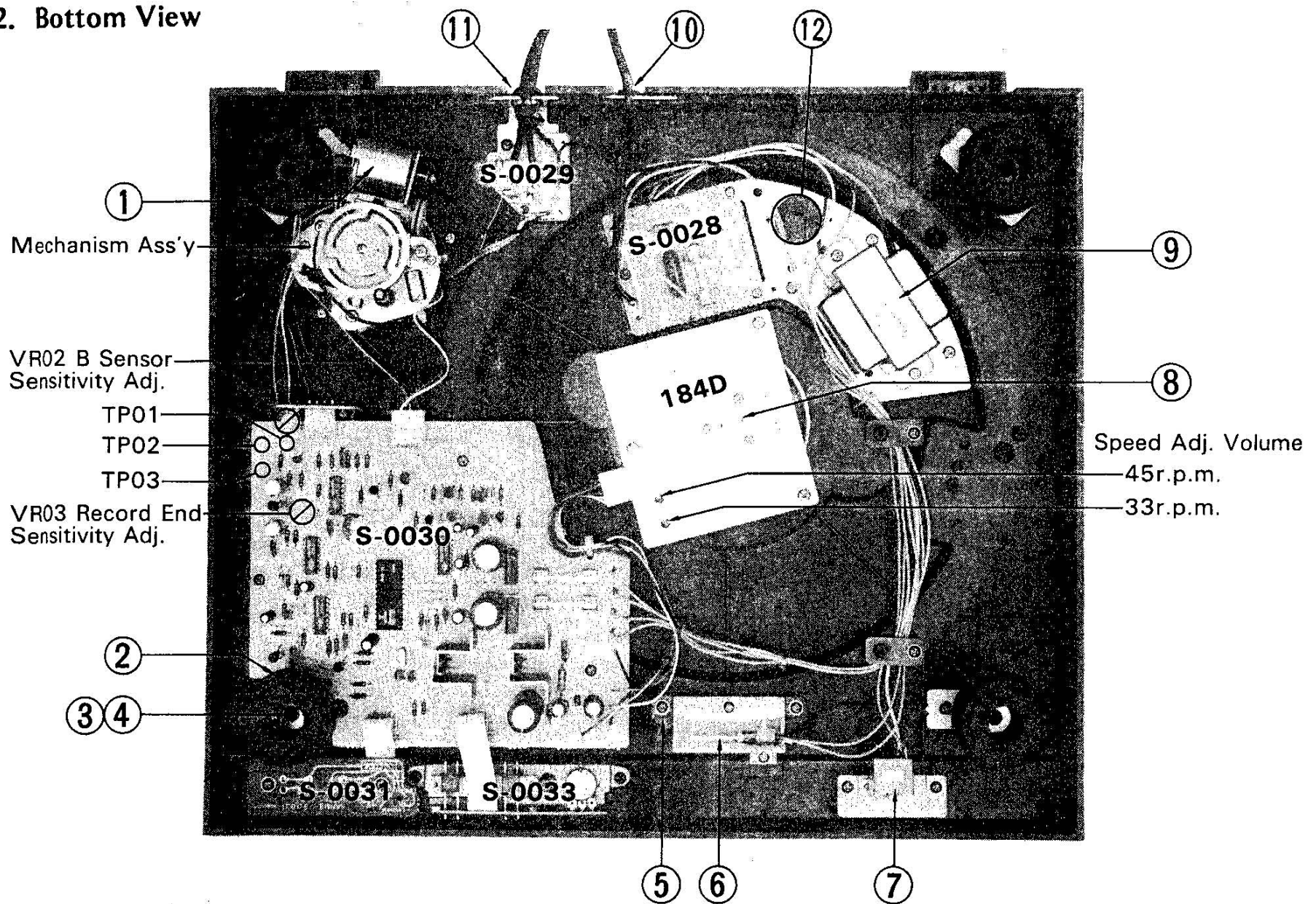

4-3. Exploded View of Mechanism Ass'y

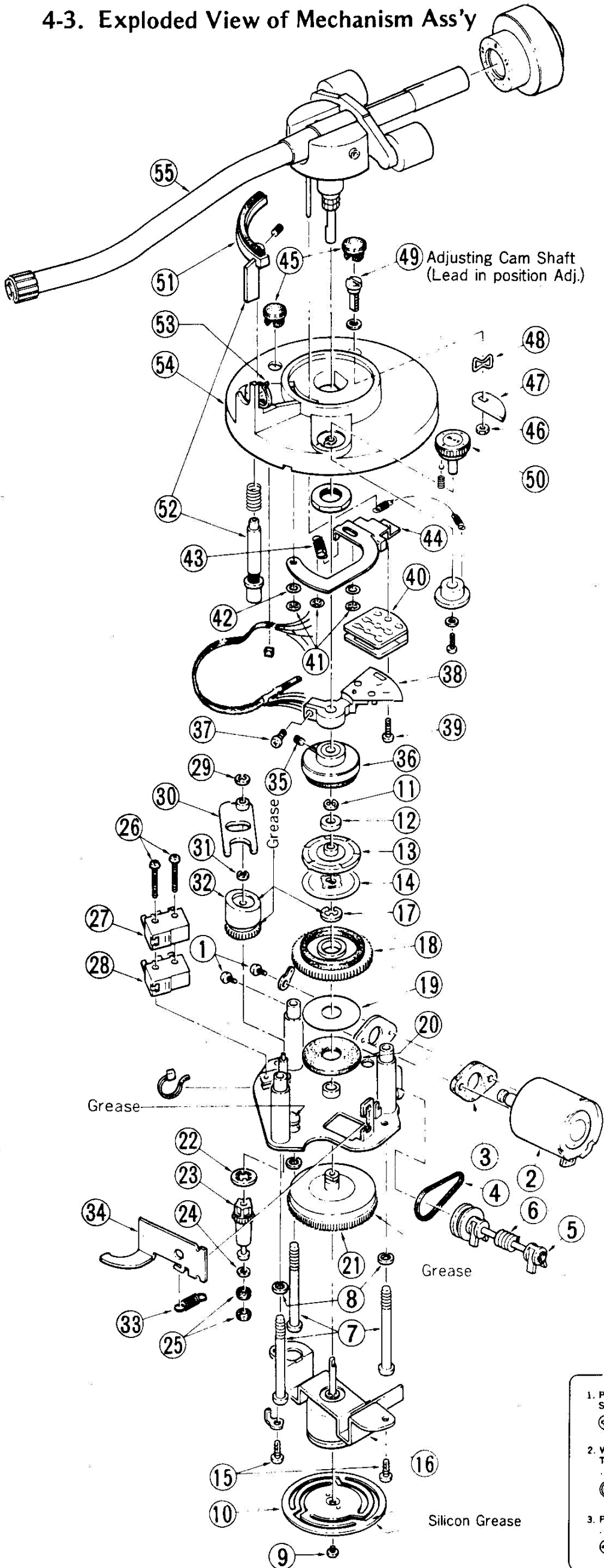

Parts No.	Stock No.	Description
1	5103002	PT Type Screw, M2 x 4
2	4320640	Micro Motor Ass'y
3	5502980	Rubber Cushion
4	6032230	Drive Belt
5	5151001	E Type Washer, D1.5
6	7032131	Worm Gear Ass'y (Worm Gear, Shaft, E Type Washer D1.5, Pulley, Bearing)
7	5162830	Tapping Screw, M4 x 42
8	5121360	S Type Washer M4.0 x 1.4
9	5103002	P Type Screw M2 x 4
10	6142370	Friction Disc
11	5151002	E Type Washer, D2.0
12	5183170	Damping Washer (2)
13	6422080	Clutch Plate (2)
14	6422070	Clutch Plate (1)
15	5103542	PT Type Screw Class 2, 3 x 8
16	4340240	Plunger Solenoid Ass'y
17	5151006	E Type Washer, D5.0
18	6002070	Gear (2)
19	5183150	Thrust Washer
20	5183160	Damping Washer (1)
21	6002060	Gear (1)
22	5183230	CS Ring, M5.0
23	6002080	Gear (3)
24	5182570	Thrust Washer, M4 x 0.5
25	6142360	Friction Pulley
26	5103010	P Type Screw, M2 x 16
27	1160270	Micro Switch,
28	1160270	Micro Switch,
29	5151002	E Type Washer, D2.0
30	6512200	Lifter Guide
31	5151002	E Type Washer, D2.0
32	6012540	Lifter Cam
33	6903410	Tension Spring (1)
34	7072131	Brakeshoe Ass'y
35	5162330	SC Type Screw, M3 x 5
36	6512190	TA Drum
37	5103542	PT Type Screw 3 x 8
38	7062381	Screen Plate Ass'y
39	5162880	P Type Screw, M2.5 x 10
40	7790010	Photo Sensor Ass'y
41	5183180	CS Ring, M2.4
42	5183200	Thrust Washer, 2.5 x 0.5
43	6903420	Tension Spring (2)
44	6503000	Sensor Mounting Arm
45	5062480	Lid
46	5110241	H Type Nut
47	6012560	Adjusting Cam (2)
48	5183210	Wave Washer, M4
49	6202570	Adjusting Cam Shaft
50	6912660	IFC Ass'y (Knob, Thread, Spring, Screw, Washer, Steel Ball)
51	7082340	Lifter Plate Ass'y
52	7082360	Lifter Ass'y (Lifter Plate Ass'y, Lifter Piston Ass'y)
53	6622310	Armrest Fook Ass'y (Fook, Screw)
54	7092930	Armbase
55	7092950	Tonearm Ass'y

● Abbreviations

1. Pan Head Tapping Screw .....PT Type	4. Pan Head SEMS A Screw .....PSA Type	7. Binding Head Screw.....B Type	10. Round Head Wood Screw .....RH Type	13. Spring Washer .....S Type
2. Washer Head Tapping Screw .....WT Type	5. Pan Head SEMS B Screw .....PSB Type	8. Flat Countersunk Head Screw .....F Type	11. Hex. Socket Setscrew .....SC Type	14. Plain Washer .....P Type
3. Pan Head Screw .....P Type	6. Binding Head SEMS F Screw .....BSF Type	9. Flat Countersunk Wood Screw .....FC Type	12. Slot Type Setscrew .....SS Type	15. Retaining Ring (E Washer) .....E Type



## 5. ADJUSTMENT

### 5-1. Auto-Return Adjustment

#### 1. Installation of Screen Plate

- 1) Place the tonearm on its rest.
- 2) Install a screen plate provisionally to the axle of tonearm as shown in Figs. 5-1 (A), (B).
- 3) Fix the screen plate firmly after "2. Adjustment of B-sensor output" is accomplished.

#### 2. Adjustment of B-sensor Output

- 1-a) Place the tonearm on its rest.
- 1-b) Connect an oscilloscope to TP01 and TP02 (GND) on S-0030.
- 1-c) Set the DC/AC mode switch of the oscilloscope to "DC", the vertical gain to 1 V/Div., and the sweep rate to 1 m sec./Div.
- 1-d) Adjust the voltage at TP01 to the middle level between 3.8 V and saturated voltage by turning VR02 (S-0032).
- 2-a) Set the vertical gain of oscilloscope to 1 V/Div., and the sweep rate to 0.1 Sec./Div.
- 2-b) Take the tonearm to the lead-out groove of disc and move it slowly inward and outward so that the slit-C of screen plate may cross the space between LED and photo transistor. By this, the waveform (A) or (B) shown in Fig. 5-2 can be observed.
- 2-c) Adjust the waveform on the display as shown in Fig. 5-2 (A) by turning VR02 (S-0032)
- \* If the amplitude of the waveform on the display is too small or too large to adjust VR02 for 2.4 V, contact or widen the gap (A) (See Fig. 5-1) between screen plate and sensor mounting board then repeat the adjustment 2-c) above.
- 3-a) Place the tonearm on its rest and confirm the voltage at TP01 is above 3.8 V.
- 3-b) Fix the screen plate firmly to the axle of tonearm.

#### 3. Sensitivity Adjustment on Record-end Detection

- 1-a) Connect an oscilloscope to TP03 and TP02 (GND).
- 1-b) Set the DC/AC mode switch of oscilloscope to "DC", the vertical gain to 0.5 V/Div. and the sweep rate to 1 m Sec./Div. (This adjustment can be performed by making use of DC voltmeter)

Fig. 5-1 Installation of Screen Plate

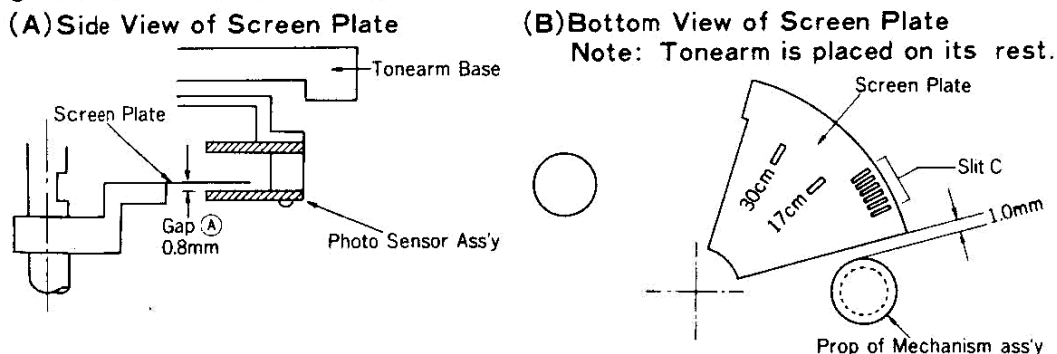

- 2-a) Place the tonearm on its rest.
- 2-b) Adjust the voltage at TP03 to 3.5 V by turning VR03 (S-0030). (In case of using DC voltmeter with input impedance of 100kΩ/V or 20kΩ/V, adjust the voltage at TP03 to 3.6 V or 3.7 V respectively.)
- 3-a) Repeat following procedures A and B until the tonearm returns automatically at the record end.
  - A Check the auto-return operation (whether the tonearm returns automatically) by making use of a 30 cm disc with narrow (approximately 4 mm) pitch lead-out groove.
  - B Turn VR03 (S-0030) to decrease the voltage at TP03 by 0.1 V.
- 4-a) Confirm that the auto-return operation is certainly performed at the record end.
- 4-b) Decrease the voltage at TP03 by 0.1 V in order to ensure the auto-return operation.
- \* In case of using DC voltmeter, remove lead wires of DC voltmeter from TP02 and TP03 when checking the auto-return operation.

### 5-2. Lead-in Position Adjustment

- 1) Confirm that the screen plate is installed as shown in Fig. 5-1 (A), (B).
- 2) Turn the adjusting cam (See 4-1 Top View, 4-3 Exploded View on page 6, 7) so as to lower the stylus to the middle of lead-in groove.

### 5-3. Speed Adjustment

- 1-a) Set the Pitch Control (VR01) on control panel to center position.
- 2-a) Set the Speed Selector to 33 (r.p.m.)
- 2-b) Adjust VR33 (See 4-2 Bottom View) so as to standstill the strobo marking pattern.
- 3-a) Set the Speed Selector to 45 (r.p.m.)
- 3-b) Adjust VR45 (See 4-2 Bottom View) so as to standstill the strobo marking pattern.

Fig. 5-2 Output Waveform Adjustment on B-Sensor

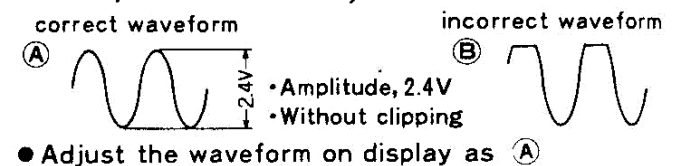
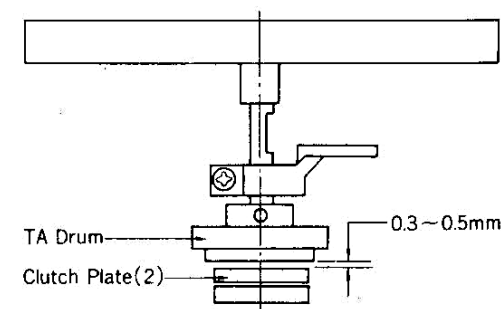

Fig. 5-3 Clearance between TA Drum and Clutch Plate (2)



## 6. MAIN PARTS REPLACEMENT (See 4-3 Exploded View on page 7)

### 6-1. Replacement of Tonearm Ass'y (55)

- 1) Remove the bottom cover.
- 2) Loosen 3 screws (7) to remove the mechanism ass'y.
- 3) Loosen the screw (35) to remove the TA drum.
- 4) Loosen the screw (37) to remove the screen plate.
- 5) Remove lead wires of the tonearm soldered on the terminal board (S-0029).
- 6) Remove the spring of inside force canceler.
- 7) Loosen the fixing nut to pull out the tonearm.

\* Refer to Figs. 5-1 (A), (B), 5-3, when installing screen plate and TA drum.

### 6-2. Replacement of Plunger Solenoid Ass'y (16)

- 1) Remove the bottom cover.
- 2) Loosen 3 screws (7) to remove the mechanism ass'y.
- 3) Remove E type washer (11).
- 4) Loosen 2 screws (15) to take out the plunger solenoid ass'y.

### 6-3. Note on Parts Replacement

- 1) When replacing friction pulleys, insert 2 pulleys to gear (3) to face their smoothed surface each other.
- 2) When replacing photo-transistors on the photo sensor ass'y, attach the photo-transistor so as to meet the center of photo-transistor to the slit of photo-sensor ass'y.

## 7. INTERIOR BLOCK DIAGRAM OF IC

● **MSM4011**

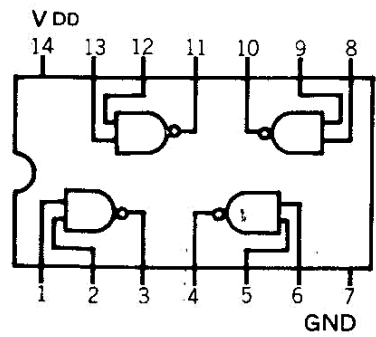

● **MSM4001**

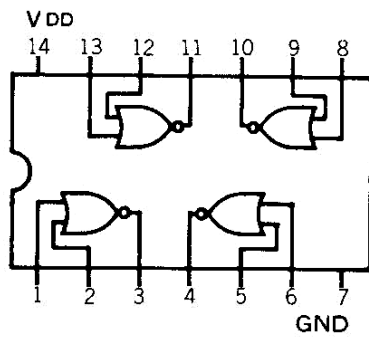

● **MSM4069**

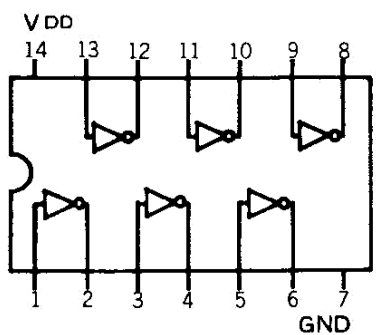

## 8. PACKING LIST

Parts No.	Stock No.	Description
1	9012320	Protector Board, Upper
2	7012221	Dustcover
3	9122111	Polyethylene Bag for Dustcover
4	9012370	Protector Board, platter
5	5502960	Rubber Mat
6	6112230	Platter
7	9116600	Polyethylene Bag for Platter
8		Turntable Unit
9	9112270	Polyethylene Bag for Turntable Unit
10	9022670	Styrofoam Packing, front
11	9022680	Styrofoam Packing, rear
12	9022660	Plastic Sheet
13	9022690	Accessory Box
14	9002871	Carton Case

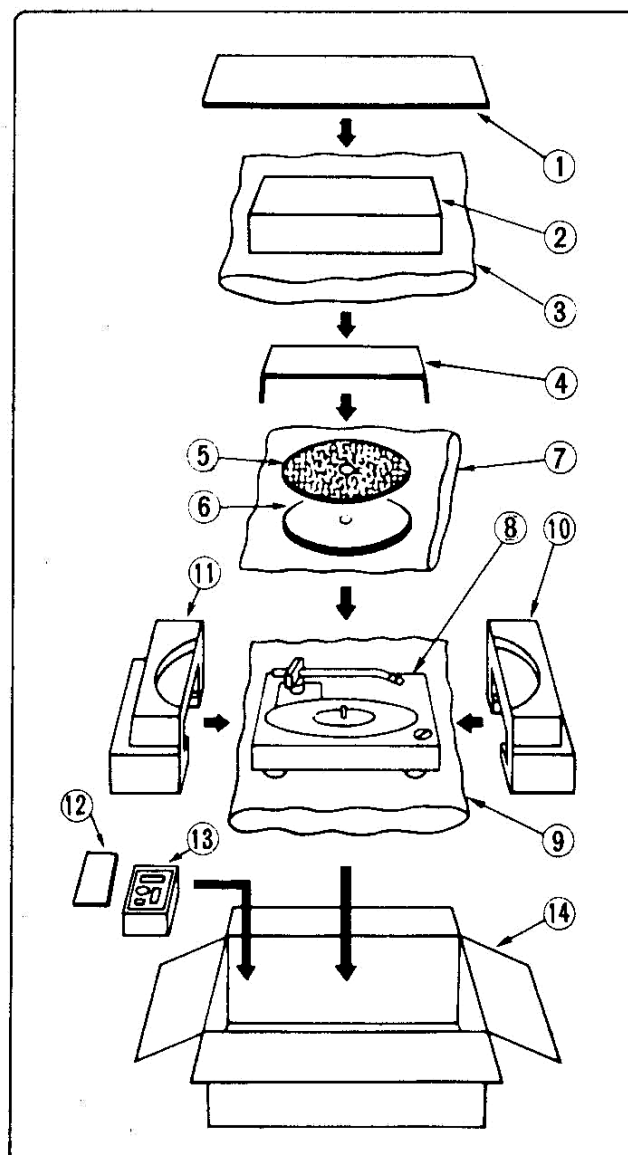

## 9. ACCESSORY PARTS LIST

Stock No.	Description
4310370	Cartridge Ass'y, SC-50 (XX)
{ 4940230	{ Stylus, SN-50 (XX)
{ 5192160	{ Screw, Ass'y
6642360	Headshell
5242590	Cartridge Mounting Gauge
6912690	Main Weight
6172040	EP Adaptor
6922410	Auto Hinge
9205170	Operating Instructions
9232300	Schematic Diagram

# 10. SCHEMATIC DIAGRAM

• Design and specifications subject to change without notice for improvement.  
 • La présentation et les spécifications sont susceptibles d'être modifiées sans préavis par suites d'améliorations éventuelles.  
 • Änderungen, die dem technischen Fortschritt dienen, bleiben vorbehalten.

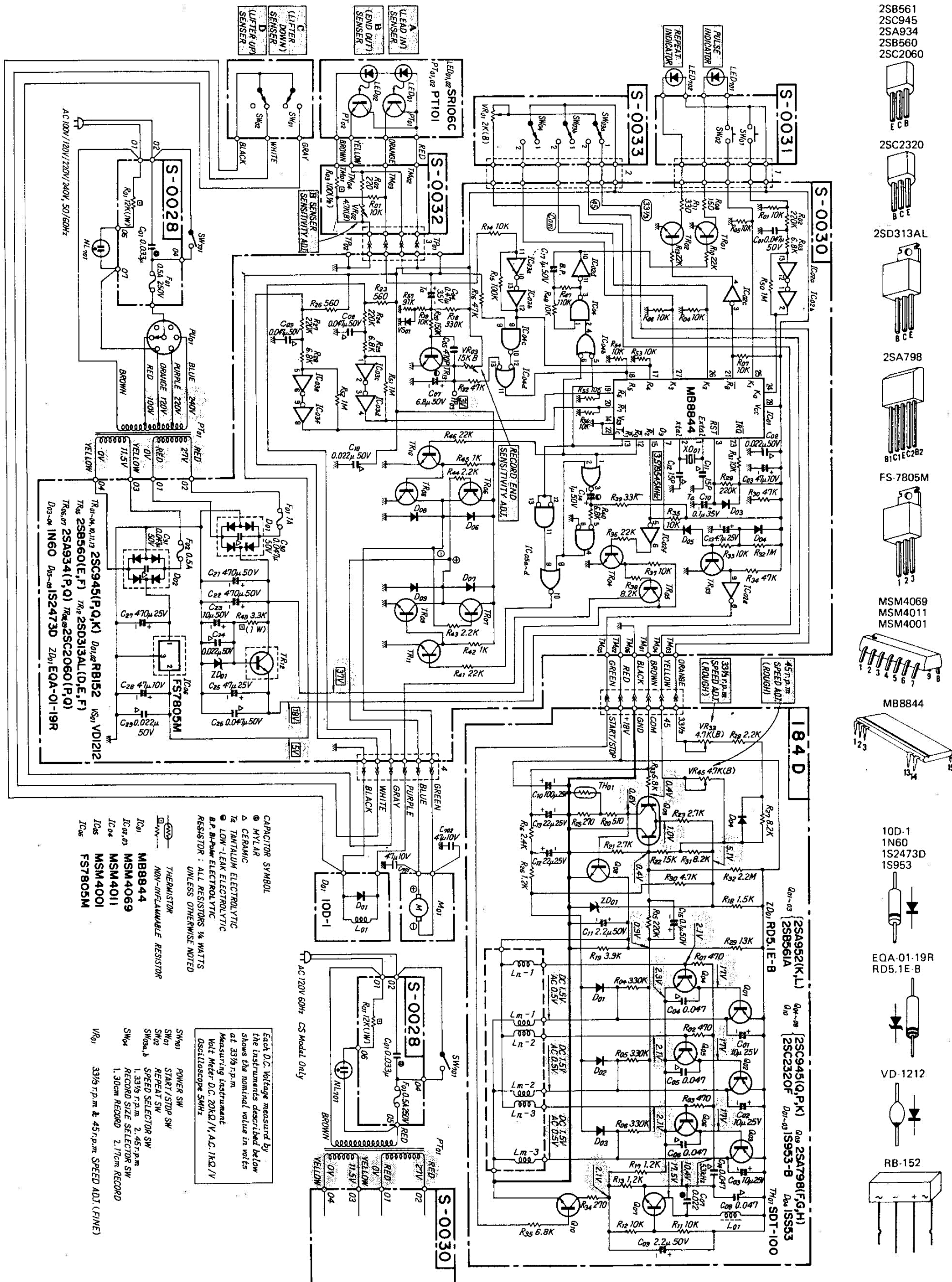

1  
2  
3  
4  
5