

SERVICE MANUAL

COMPUTERIZED FULLY AUTOMATIC
DIRECT-DRIVE TURNTABLE

SANSUI FR-D45



● SPECIFICATIONS

Type	Two-speed direct-driven
Speeds	33-1/3, 45 rpm
Platter	Aluminum alloy die-cast 315 mm (12-13/32") diameter
Motor	FG Servo DC Motor
Wow and flutter	0.025 % (W.R.M.S.)
S/N	Better than 60 dB (IEC-B)
Rumble	Better than 72 dB (DIN-B)
Tonearm	
Tonearm length	220 mm (8-11/16")
Overhang	17.5 mm (3/4")
Applicable cartridge weight	4 to 10 g
Dimensions	440 mm (17-5/16") W 127 mm (5") H 374 mm (14-11/16") D
Weight	5.6 kg (12.3 lbs) net 7.0 kg (15.4 lbs) packed
Power consumption	28 W

- The power voltage is adjusted to the one of the area where bought the unit.

Specifications of the cartridge (applicable only to the units with cartridge)

Model SC-50

Type	Induced magnet
Frequency response	10 ~ 20,000 Hz
Output voltage	3.0 mV per channel (1,000 Hz, 35.4 mm/sec)
Load impedance	47 kΩ
Tracking force	2.5 g
Stylus	0.6 mil, diamond spherical (SN-50)

Model SV-101

Type	Dual magnet
Frequency response	10 ~ 20,000 Hz
Output voltage	2.5 mV per channel (1,000 Hz, 35.4 mm/sec)
Load impedance	47 kΩ
Tracking force	2 g
Stylus	0.6 mil, diamond spherical (SN-101)

Model SV-202

Type	Dual magnet
Frequency response	10 ~ 20,000 Hz
Output voltage	2.5 mV per channel (1,000 Hz, 35.4 m/sec)
Load impedance	47 kΩ
Tracking force	2 g
Stylus	0.6 mil, diamond spherical (SN-202)

- * Design and specifications subject to change without notice for improvements.

Sansui

SANSUI ELECTRIC CO., LTD.

1. BLOCK DIAGRAM

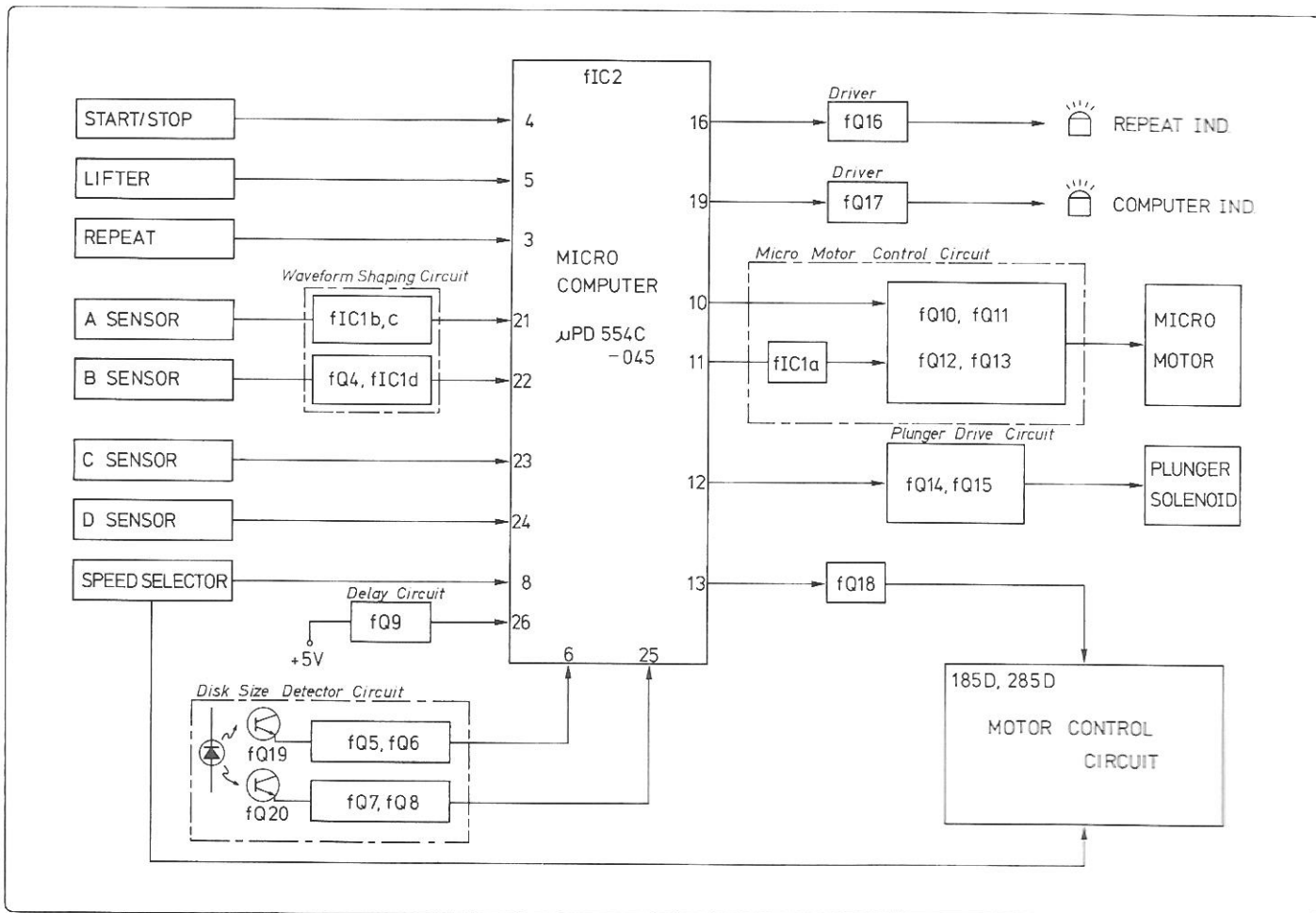

2. OPERATIONS

2-1. General

This model, FR-D45 is provided an automatic disk size detecting function in addition to the full automatic system of Sansui FR-D4/Q5.

* See FR-D4 Service Manual for operations of the automatic mechanism assembly, arm position sensor, and lifter position sensor.

* The control circuit of the FR-D45 is divided into three portions: a servo circuit to control the DD motor, a microcomputer μ PD554C to control the tone arm mainly, and its peripheral circuits.

See XR-Q9 Service Manual for operations of the microcomputer μ PD554C and its peripheral circuits.

* The automatic disk size (30 cm and 17 cm) detection is carried out by placing a prism between the LED (fLD1) in Fig. 2-1 and the photo-transistor fQ19. In case of a 30 cm disk, the light from the LED is intercepted by the disk and therefore the photo-transistor fQ19 is turned OFF. In 17 cm disk, the light from the LED reaches the photo-transistor fQ19 through the prism and therefore the photo-transistor fQ19 is turned ON.

The ON/OFF signal detected by the photo-transistor is then inputted to the pin No. 6 of the microcomputer μ PD554C. The potential level of the pin No. 6 is in L level when the fQ19 is OFF (30 cm disk) and in H level when the fQ19 is ON (17 cm disk).

In addition, the photo-transistor fQ20 detects whether or not a disk is placed on the turntable. When no disk is on the turntable, the light from the LED turns the fQ20 ON to change the pin No. 25 of the μ PD554C from L to H level. When the pin No. 25 is in H level, the return operation is performed even by depressing the start button.

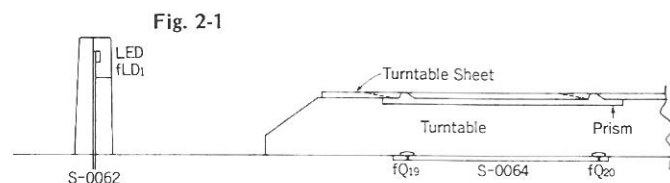

2-2. Control System of DD Motor 285D

The control system of the DD motor 285D is configured by a waveform shaping IC/PD101 and a motor control IC/PD102, as shown in Fig. 2-2 which have newly developed by Sansui.

A. Operation of Waveform Shaping IC/PD101

Fig. 2-4 shows a block diagram of the PD101. The pulse signal detected by the speed detection coil (eL701) is inputted to the pin No. 1 of the PD101 as a speed proportion pulse signal (50 Hz in 33 rpm, 67.5 Hz in 45 rpm). The inputted pulse signal is amplified by the differential amplifier, fed to the waveform shaper circuit to change the waveform into a trapezoid shape by the waveform shaping capacitor eC11 connected to the pin No. 5, and outputted through the capacitor eC14 from the pin No. 6.

B. Operation of DD Motor Control IC/PD102

Fig. 2-3 shows a block diagram of the PD102. The pulse signals detected by the position sensor coils eLn-1, eLn-2, and eLn-3 are inputted to the pins No. 2, 3, and 4, respectively.

with 120-degree phase shift in electrical angle. The upper envelope of the inputted pulse signals is detected by the envelope detection circuit, as shown in Fig. 2-6, and then inputted to the full-wave drive switching circuit in Fig. 2-5.

After inputted to the pin No. 5, the trapezoid output signal, waveform of which has already been shaped by the PD101, is fed to the sample & hold circuit through the sample pulse generator, where conversion of frequency into voltage (F/V conversion) is carried out to generate a voltage inversely proportional to the speed.

This voltage is integrated by the low-pass filter and inputted to the DC servo amplifier (differential amplifier).

This voltage is compared with the reference voltage, and the lower side of the waveform outputted from the full-wave switching circuit is servo-controlled to regulate the motor speed. The output waveform of the driving coils eLm-1, eLm-2 and eLm-3 should look like the ones shown in Fig. 2-7. The resistor of 2.2Ω connected to the pin No. 11 is used for differential switching.

Fig. 2-2 Construction of 285D DD Motor Control System

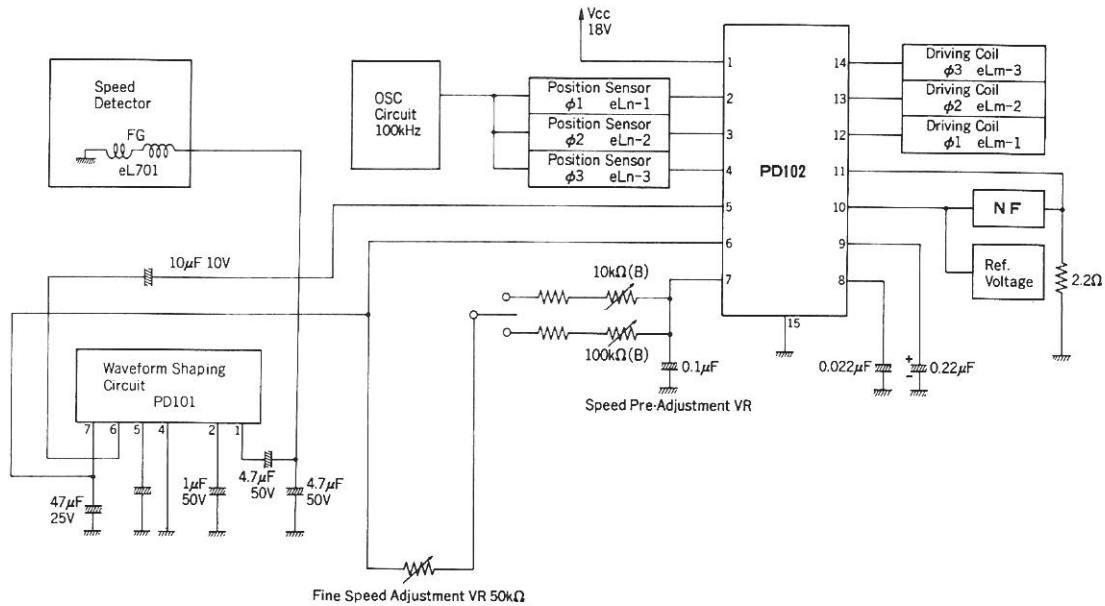
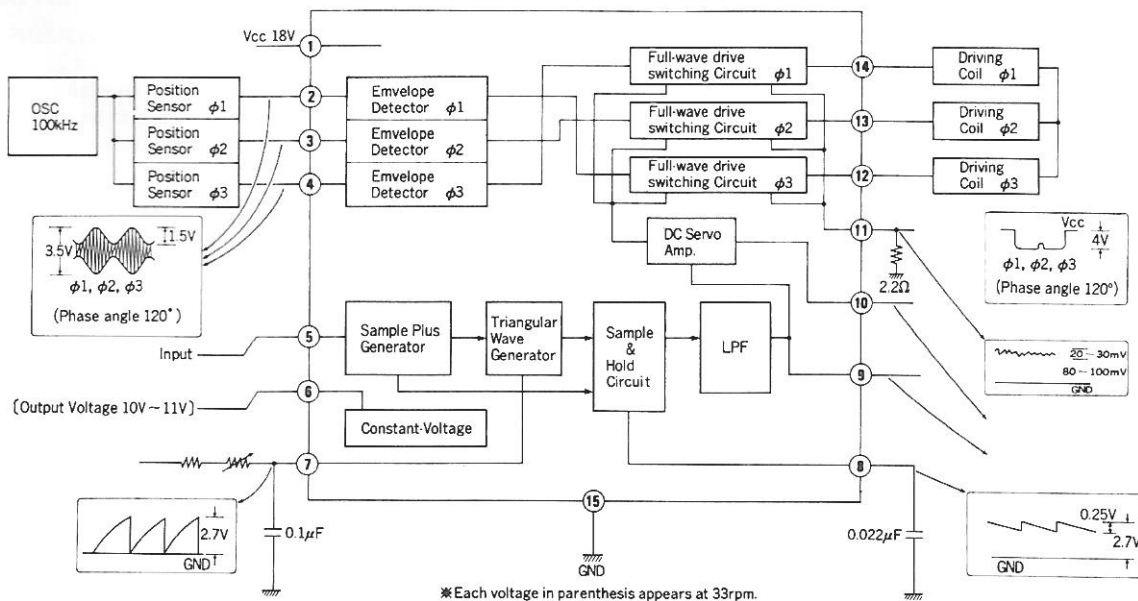

Fig. 2-3 Block Diagram of Motor Control IC/PD102



* Each voltage in parenthesis appears at 33rpm.

Fig. 2-4 Block Diagram of Waveform Shaping IC/PD101.

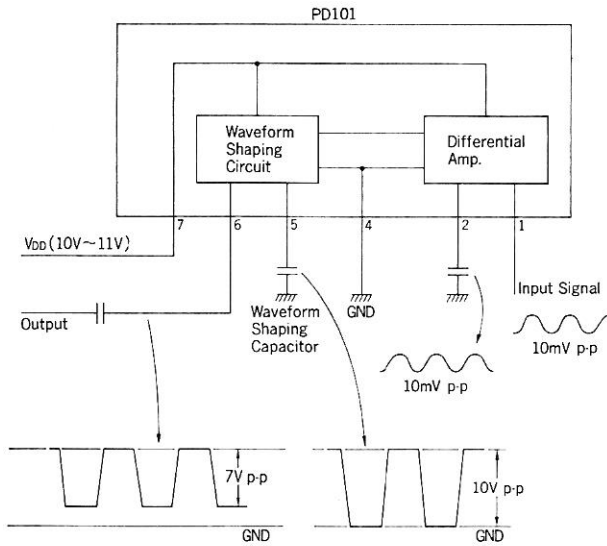
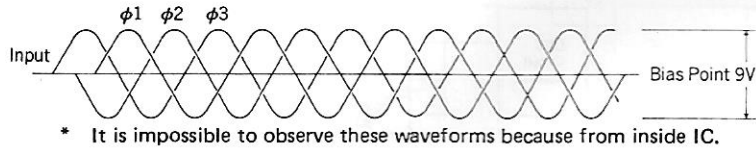
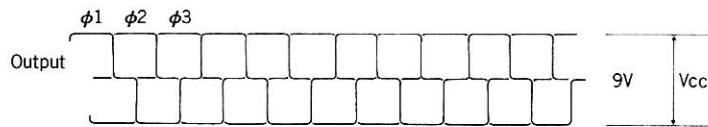

Fig. 2-7



• Output Waveform of Driving Coil

1) DC Servo OFF (Waveform appeared at high speed rotation or at start of motor)



2) DC Servo ON

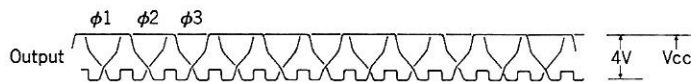

Fig. 2-5

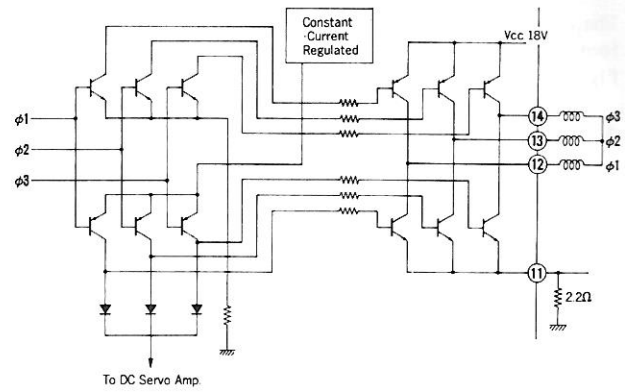
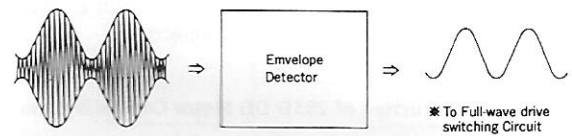

Fig. 2-6



3. ADJUSTMENTS (See Top View on Page 7)

3-1. Adjustment of Screen Plate Installation Position

Adjust the position whenever the tonearm is replaced. With the tonearm placed on the arm rest, install the screen plate to the tonearm shaft, as shown in Figs. 3-1 (A) and (B).

Fig. 3-1 Installation of Screen Plate

(A) Side View of Screen Plate

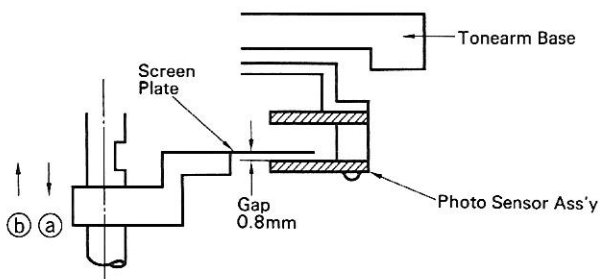

(B) Bottom View of Screen Plate

Note: Tonearm is placed on its rest

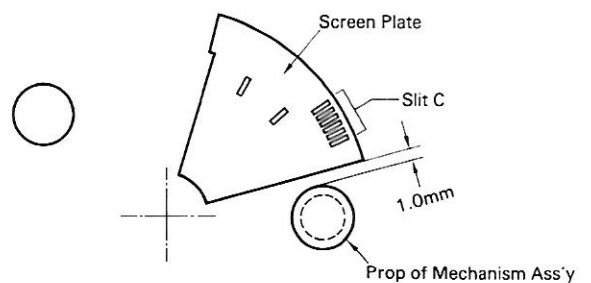

3-2. Adjustment of B Sensor Output

A. Output level adjustment

- (1) Connect the \oplus terminal of an oscilloscope to the TP₁ of S0062 and \ominus terminal to the TP₃(GND), and set the selector switch DC/AC to DC and the test ranges to 2 V/div and 10 msec/div.
- (2) Shift the tonearm by hand to the lead-out groove on the record disc, and slowly move the tonearm right and left in such a way that it takes about two seconds for the slit C of Fig. 3-1 to pass through between the LED and the phototransistor.
- (3) During this movement, adjust the output level by rotating the volume (fVR₁) of S0062 so as to be set between 4.5 and 8 V without any distortion of the waveform, as shown in Fig. 3-2.
- (4) If it is impossible to adjust the output level to 4.5 V or more, reduce the gap distance between the screen plate and the photo sensor assembly to 0.8 mm or less, as shown in Fig. 3-1.

Fig. 3-2 Output Waveform Adjustment on B-Sensor

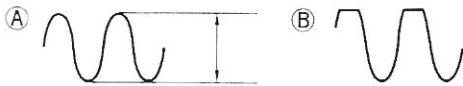

B. Duty ratio adjustment of output pulse waveform

- (1) Connect an oscilloscope across the TP₂ of S0062 and GND, and set the selector switch to DC and the test ranges to 2 V/div and 0.01 sec/div.
- (2) Shift the tonearm by hand to the lead-out groove on the record disc, and slowly move the tonearm right and left in such a way that it takes about two seconds for the slit C of Fig. 3-1 to pass through between the LED and the phototransistor.
- (3) During this movement, adjust the duty ratio of the output pulse waveform by rotating the volume (fVR₂) of S0062, as shown in Fig. 3-3.

Fig. 3-3

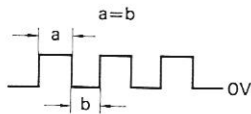

3-3. Lead-in Position Adjustment

- (1) Confirm that the screen plate is installed as shown in Figs. 3-1 (A), (B).
- (2) Turn the adjusting cam (See 6-1. Top View, 5. Exploded View) so as to lower the stylus to the middle of lead-in groove.

3-4. Speed Adjustment

- 1-a) Set the Pitch Control (hVR₁) on control panel to center position.
- 2-a) Set the Speed Selector to 33 (r.p.m.)
- 2-b) Adjust eVR₃₃ on the D.D. Motor Control Circuit Board (See 6-2. Bottom View on page 7.) so as to standstill the strobo marking pattern.
- 3-a) Set the Speed Selector to 45 (r.p.m.)
- 3-b) Adjust eVR₄₅ on the D.D. Motor Control Circuit Board (See 6-2. Bottom View on page 7.) so as to standstill the strobo marking pattern.

3-5. Lifter Height Adjustment

Adjust the stylus tip and the disk as shown in Fig. 3-4, by rotating the screw (B) (See 6-1. Top View on page 7).

Fig. 3-4

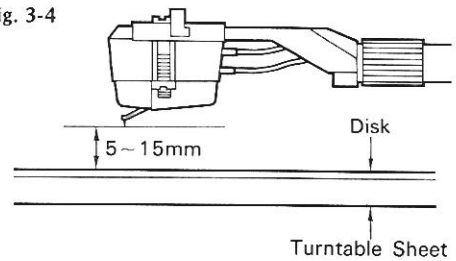

3-6. Gap Adjustment between Plunger Solenoid and Plunger Plate

When the automatic mechanism assembly parts such as the tonearm assembly, slit plate, TA drum, or clutch plate are replaced with new ones, adjust a gap between the plunger solenoid and the plunger plate so as to be 0.2 to 0.3 mm by pushing the plunger plate up as shown in Fig. 3-5.

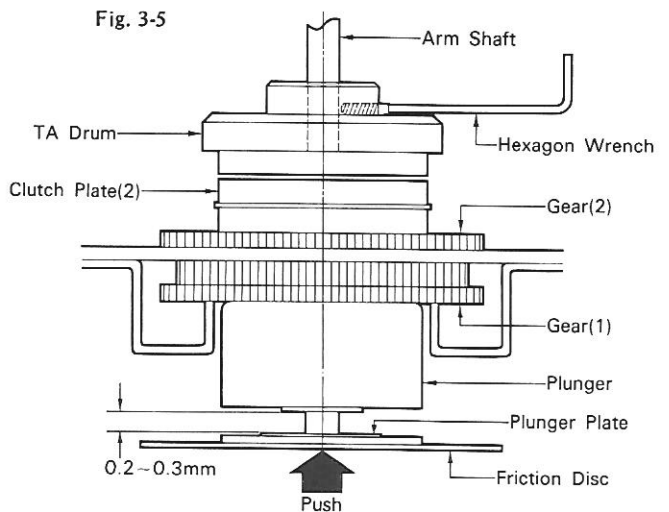

3-7. Adjustment of Disc Size Detector LED Position

When the disc size detector LED is replaced, adjust its position as shown in Fig. 3-6.

Fig. 3-6

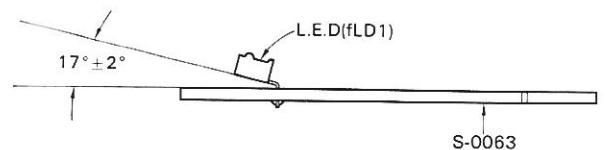

4. PARTS LOCATION & PARTS LIST

4-1. S-0062 T.A. Control Circuit Board (Stock No. 13051101)

• Since some of capacitors and resistors are omitted from parts lists in this Service Manual, refer to the Common Parts List for capacitors & resistors, which was appended previously to Sansui Manual.

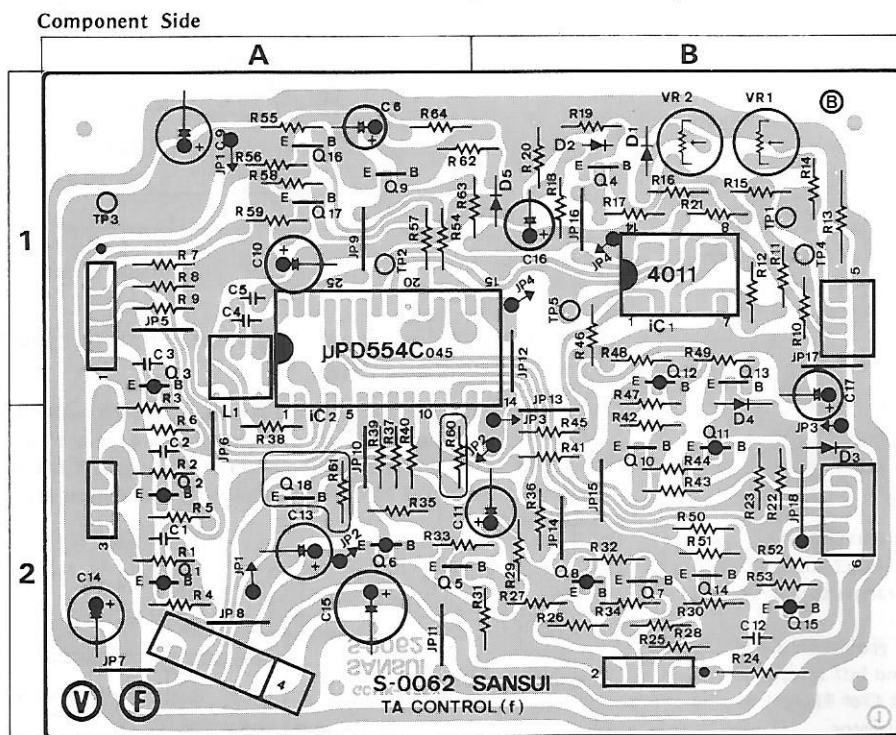

Parts List

Parts No.	Stock No.	Description
● Transistor		
fQ1	07194700, 1	2SA1015 Y, GR
	07197001, 2	2SA733A Q, P
fQ2	07194700, 1	2SA1015 Y, GR
	07197001, 2	2SA733A Q, P
fQ3	07194700, 1	2SA1015 Y, GR
	07197001, 2	2SA733A Q, P
fQ4	07194800	2SC1815 Y
	03059501	2SC945 Q
fQ5	07194800, 1	2SC1815 Y, GR
	03059501 ~ 3	2SC945 Q, P, K
fQ6	07194700, 1	2SA1015 Y, GR
	07197001, 2	2SA733A Q, P
fQ7	07194800, 1	2SC1815 Y, GR
	03059501 ~ 3	2SC934 Q, P, K
fQ8	07194700, 1	2SA1015 Y, GR
	07197001, 2	2SA733A Q, P
fQ9	07194800, 1	2SC1815 Y, GR
	03059501 ~ 3	2SC945 Q, P, K
fQ10	07194800, 1	2SC1815 Y, GR
	03059501 ~ 3	2SC945 Q, P, K
fQ11	07254800, 1	2SA854 Q, R
fQ12	07194700, 1	2SA1015 Y, GR
	07197001, 2	2SA733A Q, P
fQ13	07254900, 1	2SC1741 Q, R
fQ14	07194800, 1	2SC1815 Y, GR
	03059501 ~ 3	2SC945 Q, P, K
	03012200, 3	2SA934 P, Q
fQ15	07260000 ~ 2	2SA935 P, Q, R
	07270700 ~ 2	2SA881 P, Q, R
fQ16	07194800, 1	2SC1815 Y, GR
	03059501 ~ 3	2SC945 Q, P, K

Parts No.	Stock No.	Description
fQ17	07194800, 1	2SC1815 Y, GR
	03059501 ~ 3	2SC945 Q, P, K
		<185D V-Servo Motor Only>
fQ18	07194800, 1	2SC1815 Y, GR
	03059501 ~ 3	2SC945 Q, P, K
		<285 FG-Servo Motor Only>
fQ18	07206901	2SC2001 L
	03069101, 2	2SC2060 Q, R
	07270601, 2	2SC2673 Q, R
	03085202	2SD438 F
	03085901, 2	2SD471 L, K
● IC		
fIC1	07207200	MB84011BM
	03604100	TC4011P
fIC2	07260600	μPD554C-045
● Diode		
fD1	03111600	1S2473D
fD2	03401200	VD1212 (Varistor)
fD3	03111600	1S2473D
fD4	03111600	1S2473D
fD5	03103400	10D-1
fL1	42306100	OSC Coil 455 kHz
fVR1	10351100	Semi Variable Resistor 4.7 kΩ (B), (B Sensor Sensitivity ADJ.)
fVR2	10351500	Semi Variable Resistor 22 kΩ (B), (Record End Sensitivity ADJ.)

4-2. S-0066 Power Supply Circuit Board (Stock No. 13051501)

Component Side

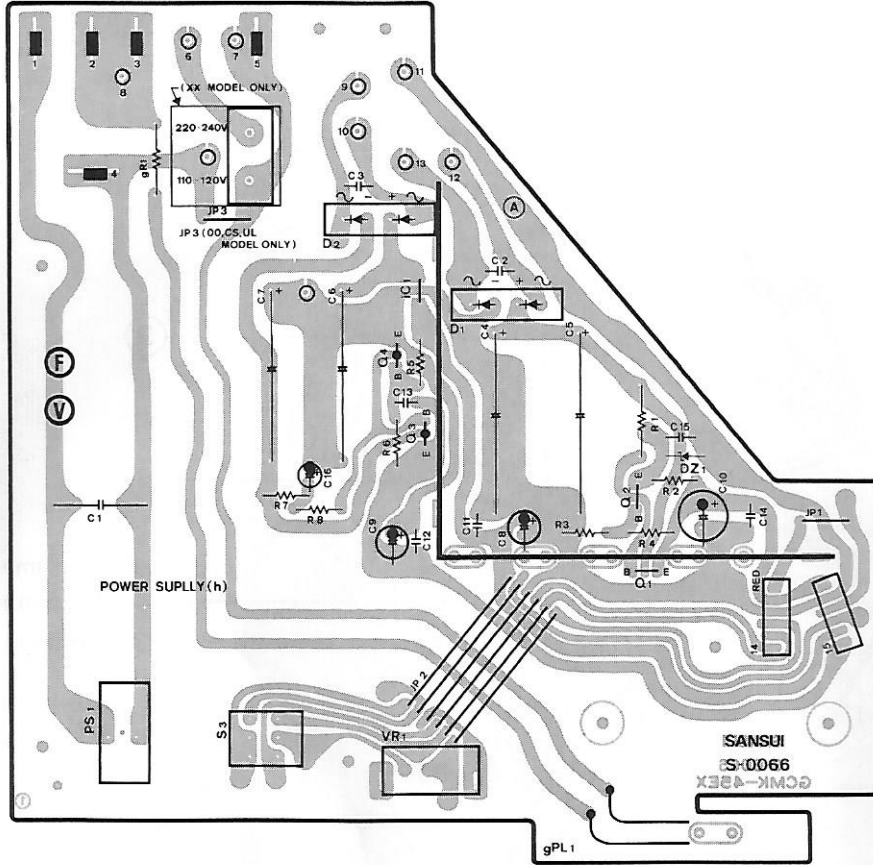

Parts List

Parts No.	Stock No.	Description
gR1	00189900	120kΩ 1W N.I.R.
gNL1	07253900	Lamp
● Transistor		
hQ1	03070400	2SC1983
	03068500, 1	2SC1844 F, E
hQ2	03062801, 2	2SC1735 D, E
	03059301	2SC1211 D
hQ3	03034401, 2	2SB527 D, E
hQ4	Q7194700, 1	2SA1015 Y, GR
	Q7197001, 2	2SA733A Q, P
● IC		
hIC1	07183500	μPC78M05H
	03609200	FS7805M
● Diode		
hD1	03117000	RB-152
hD2	03117000	RB-152
● Zener Diode		
hDZ1	03166300	RD5.1E
hR1	00184400	680Ω 1W N.I.R.
hC1	00386000	10000 pF 150 V C.C.
hC2	00407800	0.047μF 100 V M.C.
hC3	00407800	0.047μF 100 V M.C.
hC4	00283400	470μF 50 V E.C.
hC5	00283400	470μF 50 V E.C.
hC6	00281800	470μF 25 V E.C.
hC7	00281800	470μF 25 V E.C.
hVR1	07247300	Variable Resistor 2 kΩ, speed control (185D V-Servo Motor Only)
	46036000	Variable Resistor 50 kΩ (B), speed control (285D FG-Servo Motor Only)
hDS1	07260300	Push Switch

● Note:

The circuit boards, S-0065, S-0063 & S-0064 are not supplied as the assembled. However, individual parts on the circuit board are provided by orders.

4-3. S-0065 Indicator Circuit Board

Component Side

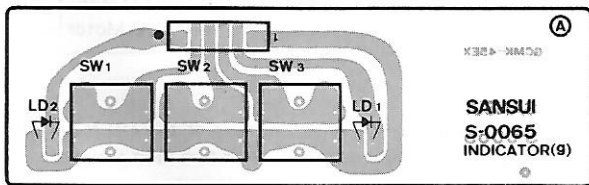

Parts List

Parts No.	Stock No.	Description
gLD1	03192500	Light Emitting Diode PR5534S
gLD2	07246200	Light Emitting Diode SEL1710K
gS1	11907000	Push Switch, repeat switch
gS2	11907000	Push Switch, lifter
gS3	11907000	Push Switch, start/stop

4-4. S-0063 Sensor L.E.D. Circuit Board

Parts List

Parts No.	Stock No.	Description
fLD1	07260900	Light Emitting Diode GL-430

4-5. S-0064 Sensor Circuit Board

Parts List

Parts No.	Stock No.	Description
● Transistor		
fQ19	03900100	Phototransistor PH101
fQ20	03900100	Phototransistor PH101

● Abbreviations

C.R. . . . Carbon Resistor	E.L. . . . Low Leak Electrolytic Capacitor
S.R. . . . Solid Resistor	E.B. . . . Bi-Polar Electrolytic Capacitor
Ce.R. . . . Cement Resistor	E.BL. . . . Low Leak Bi-Polar Electrolytic Capacitor
M.R. . . . Metal Film Resistor	Ta.C. . . . Tantalum Capacitor
F.R. . . . Fusing Resistor	F.C. . . . Film Capacitor
N.I.R. . . . Non-Inflammable Resistor	M.P. . . . Metallized Paper Capacitor
C.C. . . . Ceramic Capacitor	P.C. . . . Polystyrene Capacitor
C.T. . . . Ceramic Capacitor, Temperature Compensation	G.C. . . . Gimmick Capacitor
E.C. . . . Electrolytic Capacitor	

5. EXPLODED VIEW OF MECHANISM Ass'y & PARTS LIST

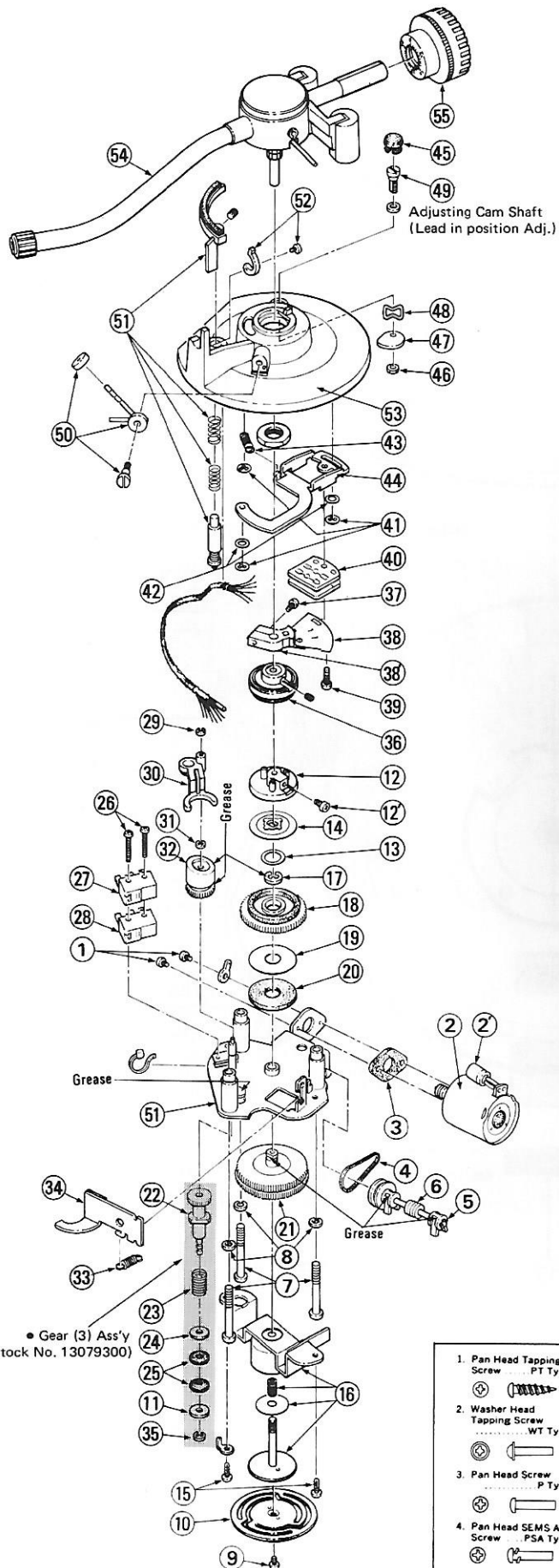

Parts List

Parts No.	Stock No.	Description
1	00436500	P Type Screw , M2 x 4
2	43206400	Micro Motor Ass'y
2'	00304000	47 μ F 10V E.B.
3	55029810	Rubber Cushion
4	60322310	Drive Belt
5	00488900	E Type Washer, D1.5
6	13011110	Worm Gear Ass'y (Worm Gear, Shaft, E Type Washer D1.5)
7	13073100	Tapping Screw, M4 x 35
8	00469800	S Type Washer, M4 x 14
9	00436500	P Type Screw , M2 x 4
10	61423710	Friction Disc
11	13033510	Washer, Friction Pulley
12	13034010	Clutch Plate (2)
12'	13044700	Tapping Screw, M3 x 6
13	13021800	P Type Washer, M7 x 11
14	64220700	Clutch Plate (1)
15	00454500	PT Type Screw Type 2, 3 x 8
16	07266100	Plunger Solenoid Ass'y
17	00489400	E Type Washer, D5.0
18	60020710	Gear (2)
19	51831500	Thrust Washer
20	51831610	Damping Washer (1)
21	13033800	Gear (1)
22	13033910	Gear (3)
23	13033600	Spring, Friction Pulley
24	00466500	P Type Washer, M3 x 8
25	13033710	Friction Pulley
26	08320400	P Type Screw , M2 x 16
27	11602700	Micro Switch
28	11602700	Micro Switch
29	00488900	E Type Washer, D1.5
30	13034610	Lifter Guide
31	00489000	E Type Washer, D2.0
32	13064500	Lifter Cam Ass'y
33	13045200	Tension Spring (3)
34	64020310	Brake Shoe
	55221000	Brake Felt
35	00489000	E Type Washer, D2.0
36	65121930	TA Drum Ass'y
37	07104500	PT Type Screw, 3 x 10
38	13040600	Screen Plate
38'	13038710	Screen Plate Base
39	13057400	Tapping Screw, M2.5 x 8
40	07209700	Photo Sensor Ass'y
41	51831800	CS Ring, M2.4
42	13052600	Thrust Washer, 3 x 0.5
43	69034200	Tension Spring (2)
44	13039400	Sensor Mounting Arm
45	50624800	Lid
46	00463600	H Type Nut, M3 x 2.4
47	60125600	Adjusting Cam (2)
48	51832100	Wave Washer, M4
49	13040700	Adjusting Cam Shaft
50	13074200	IFC Ass'y
51	13074500	Lifter Ass'y
52	13074400	Armrest Hook Ass'y
53	13074300	Arm Base Ass'y
54	13074000	Tone Arm Ass'y
55	13074100	Main Weight Ass'y

Abbreviations

1. Pan Head Tapping Screw ... PT Type	5. Pan Head SEMS B Screw ... PSB Type	9. Flat Counter Sunk Wood Screw ... FC Type	13. Binding Head SEMS B Screw ... BSB Type	17. Toothed Lock Washer (External) TLE Washer
2. Washer Head Tapping Screw ... WT Type	6. Binding Head SEMS F Screw ... BSF Type	10. Round Head Wood Screw ... RH Type	14. Spring Washer ... S Type	18. Wave Washer
3. Pan Head Screw ... P Type	7. Binding Head Screw ... B TYPE	11. Hex. Socket Setscrew ... SC Type	15. Plain Washer ... P Type	19. Hexagon Nut H Type Nut
4. Pan Head SEMS A Screw ... PSA Type	8. Flat Counter Sunk Head Screw ... F Type	12. Slot Type Setscrew ... SS Type	16. Retaining Ring (E Washer) E Type	

6. OTHER PARTS

6-1. Top View

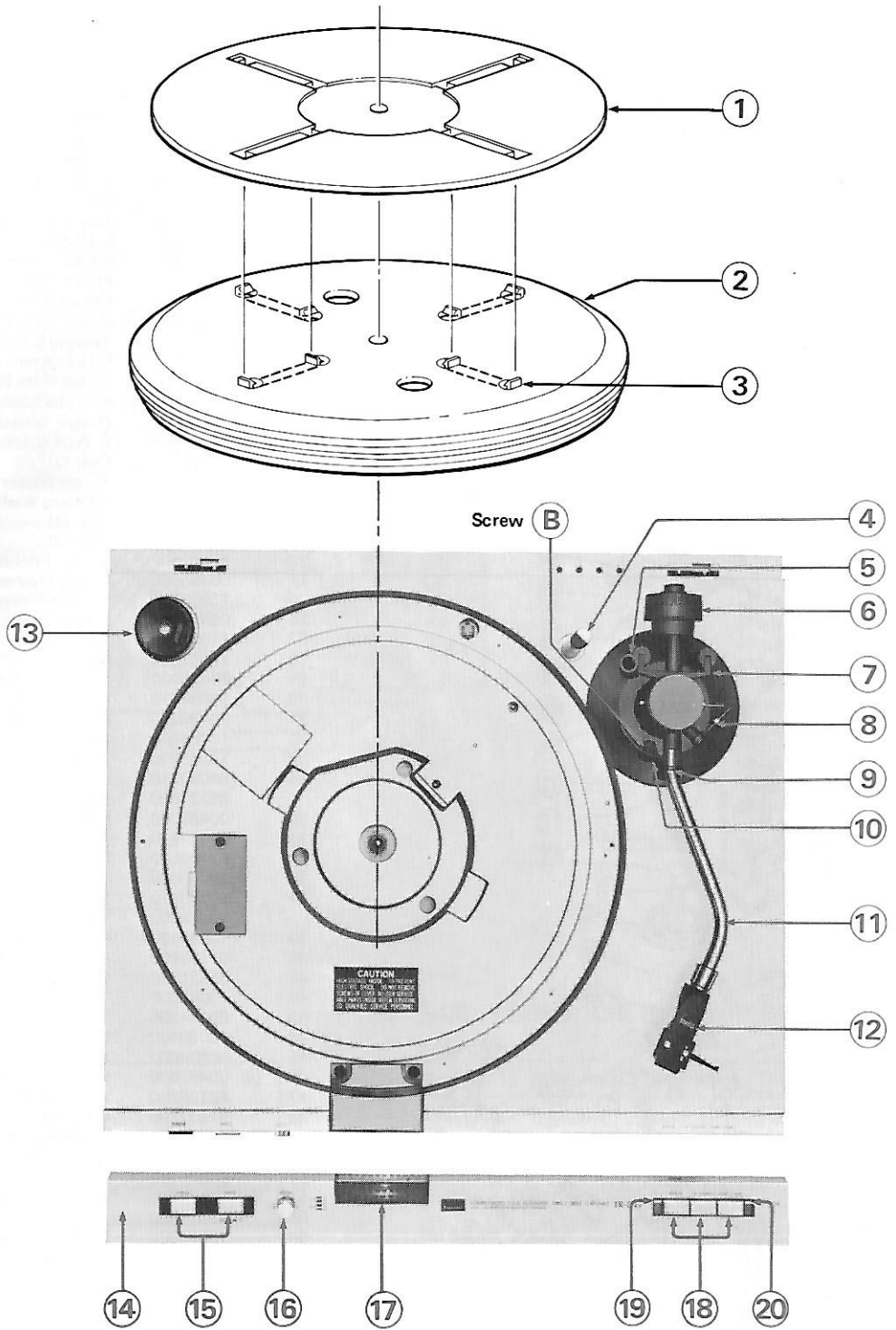

6-2. Bottom View

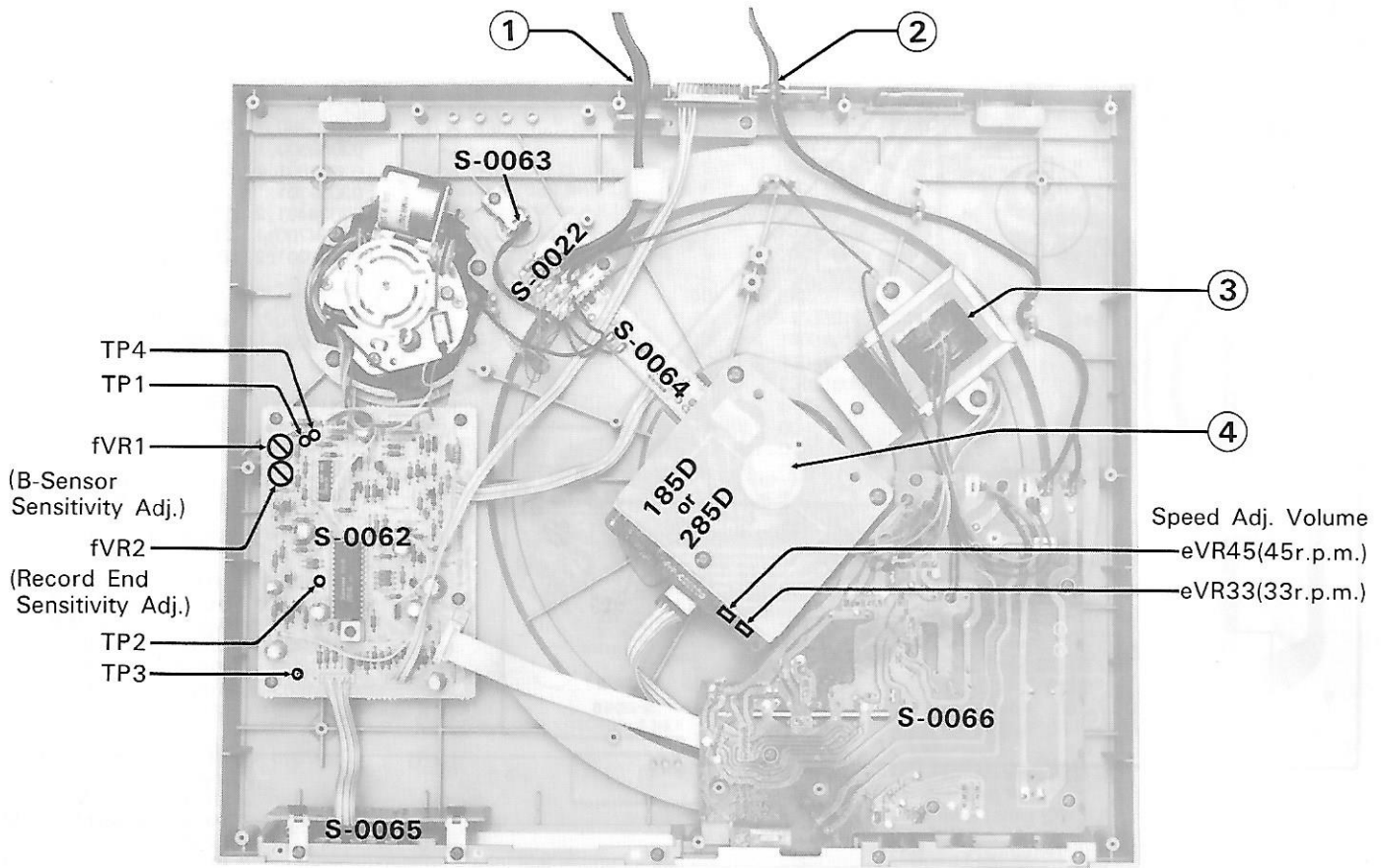

Parts List <Top View>

Parts No.	Stock No.	Description
1	13036400	Rubber Mat
2	13040000	Turntable Platter
3	13037900	Prism, Disk Size Detector
4	13076200	Disk Size Detector Post Ass'y
5	50624800	Lid
6	13074100	Main Weight Ass'y
7	13074300	Arm Base Ass'y
8	13074200	I.F.C. Ass'y
9	13074400	Armrest Hook Ass'y
10	13074500	Armlifter Ass'y
11	13074000	Tone Arm Ass'y
12	13043100	Head Shell
13	13012300	EP Adaptor
14	13064600	Front Panel Ass'y
15	13037000	Push Knob, power, speed selector
	13039800	Push Knob Guide (B)
16	13037100	Knob, pitch control
17	13037700	Strobo Cover
18	13037300	Push Knob Ass'y, repeat, up/down, start/stop
	13037000	Push Knob
	13036800	Push Knob Guide (C)
19	13037800	Indicator Plate (Red)
20	13039600	Indicator Plate (Green)
	13034100	Insulator

Parts List <Bottom View>

Parts No.	Stock No.	Description
1	38103610	P.U. Output Cord
2	38004700	Power Supply Cord
	39106000	Strain Relief
3	15002501	Power Transformer
4	* { 13051000	185D V Servo DD Motor
	{ 13065700	285D FG Servo DD Motor

} With control circuit board

* Note :
When ordering the motor unit, the type of the DD MOTOR (185D or 285D) must be confirmed because of two kind are used.

A

B

C

D

7. SCHEMATIC DIAGRAM 7-1. 185D V-Servo DD Motor

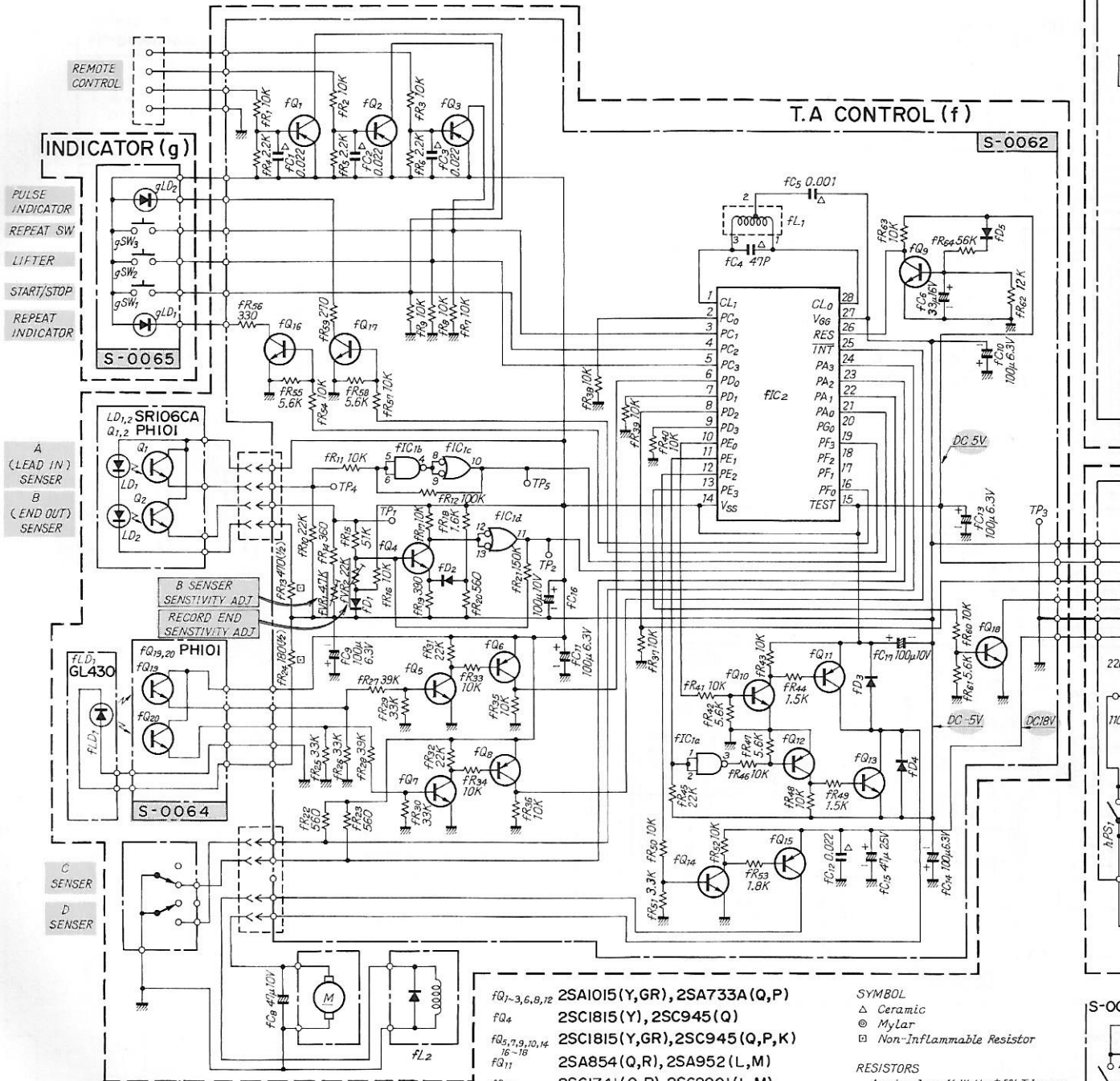

PULSE INDICATOR
REPEAT SW
LIFTER
START/STOP
REPEAT INDICATOR

A
(LEAD IN) SENSER
B
(END OUT) SENSER

C
SENSER
D
SENSER

gLD₁ PR5534S
gLD₂ SEL1710K

- FQ_{1-3,6,8,12} 2SA1015 (Y,GR), 2SA733A (Q,P)
- FQ₄ 2SC1815 (Y), 2SC945 (Q)
- FQ_{5,7,9,10,14,16-18} 2SC1815 (Y,GR), 2SC945 (Q,P,K)
- FQ₁₁ 2SA854 (Q,R), 2SA952 (L,M)
- FQ₁₃ 2SC1741 (Q,R), 2SC2001 (L,M)
- FQ₁₅ 2SA934 (P,Q,R), 2SA935 (P,Q,R)
- FQ_{19,20} PHI01
- FD_{1,3,4,6} IS2473D
- FD₂ VD1212
- FD_{5,7} 10D1
- FIC₁ MB8401IBM, TC4011P
- FIC₂ μPD554C-045

SYMBOL
△ Ceramic
△ Mylar
□ Non-Inflammable Resistor

RESISTORS
Are in ohms, 1/4 Watts, ±5% Tolerance
Unless Otherwise Noted. K: kΩ, M: MΩ

CAPACITORS
Are in μF, Unless Otherwise Noted. P: pF

Each D.C. Voltage measured by the instruments described below shows the nominal value in volts at 33% rpm. Measuring instruments. Volt Meter Oscilloscope

MOTOR-CONTROL (e)

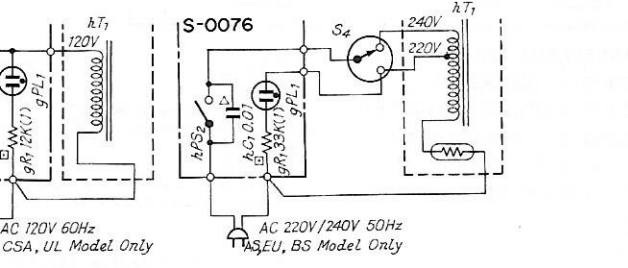
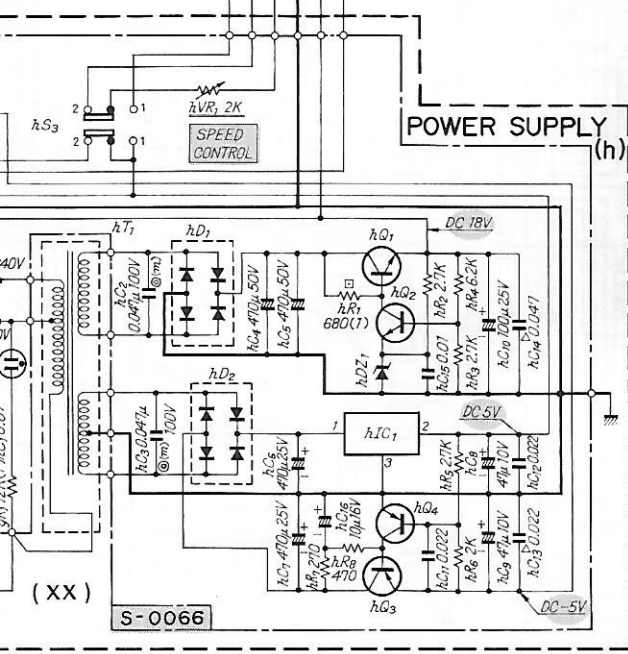
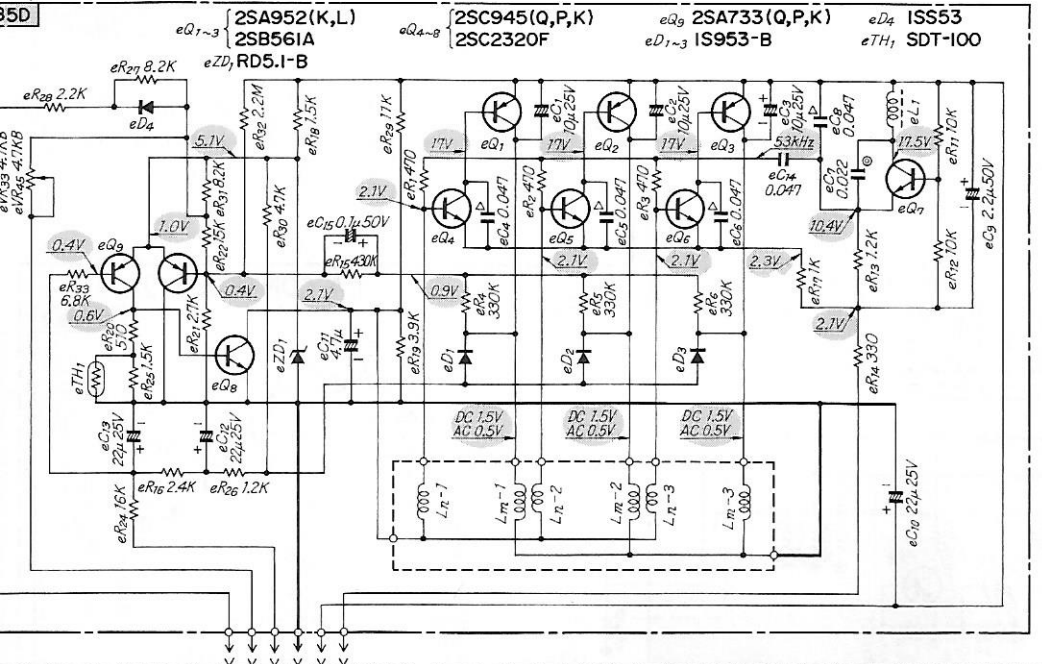

- hQ1, 2SC1983
- hQ2, 2SC1844 (F,E)
- hQ3, 2SC1735 (D,E)
- hQ4, 2SC1211 (D)
- hQ5, 2SB527 (D,E)
- hQ6, 2SA1015 (Y,GR)
- hQ7, 2SA733A (P,Q)
- hD1, RB-152
- hD2, RD5.1E
- hIC1, µPC78M05H FS7805M

SYMBOL OF FUNCTION
 (e) MOTOR-CONTROL
 (f) T.A CONTROL
 (g) INDICATOR
 (h) POWER SUPPLY

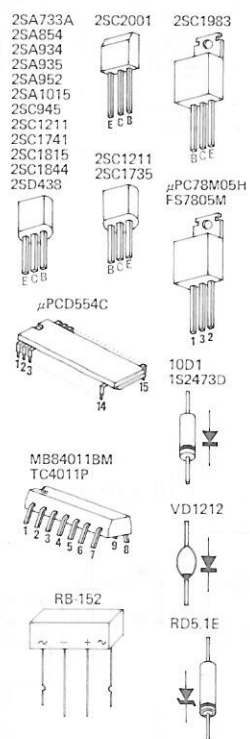

Note:
 As to C.S.A., U.L., B.S., E.U., A.S. and XX marked in the schematic diagram, note the followings:
 C.S.A., U.L. Circuit in the unit which is applicable to the Canada and U.S.A. under industrial standards.
 B.S. Circuit in the unit which is applicable to British under industrial standards.
 E.U. Circuit in the unit which is applicable to Sweden, Denmark, Norway, Finland, West Germany, and Switzerland under industrial standards.
 A.S. Circuit in the unit which is applicable to Australia under industrial standards.
 XX Circuit in the unit which is applicable to other countries excepting mentioned above.

1

2

3

4

5

7-2. 285D FG-Servo DD Motor

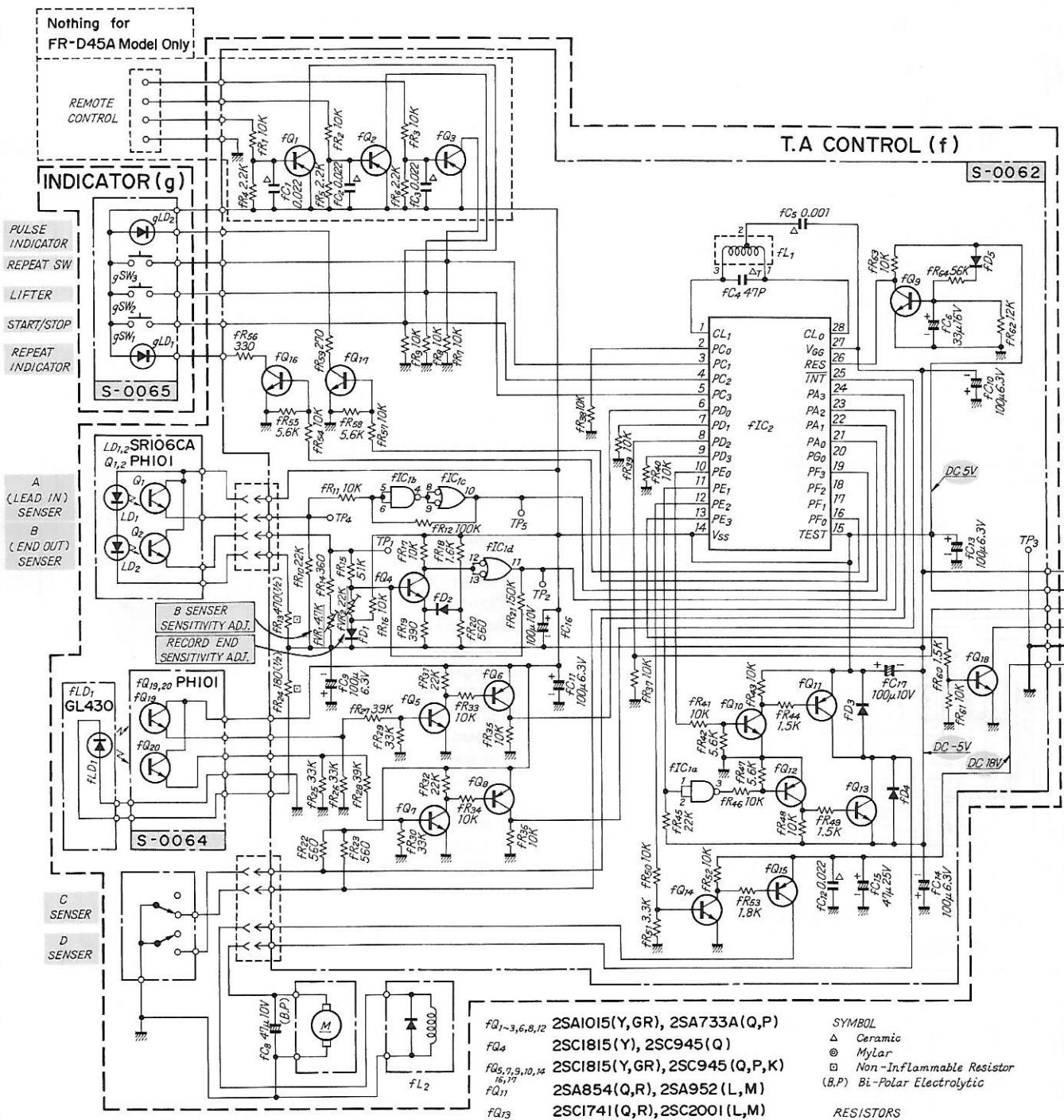

gLD₁ PR5534S
 gLD₂ SEL1710K

- fQ_{1-3,6,8,12} 2SA1015(Y,GR), 2SA733A(Q,P)
- fQ₄ 2SC1815(Y), 2SC945(Q)
- fQ_{5,7,9,10,14} 2SC1815(Y,GR), 2SC945(Q,P,K)
- fQ₁₁ 2SA854(Q,R), 2SA952(L,M)
- fQ₁₃ 2SC1741(Q,R), 2SC2001(L,M)
- fQ₁₅ 2SA934(Y,Q,R), 2SA935(P,Q,R)
- fQ_{19,20} PH101
- fD_{1,3,4,6} IS2473D
- fD₂ VDI212
- fD_{5,7} 10D1
- fIC₁ MB8401IBM, TC4011P
- fIC₂ μPD554C-045
- fQ₁₈ 2SC2060(Q,R), 2SD471(L,K)
 2SC2673(Q,R), 2SD438(F)
 2SC1211(E), 2SC2001(L)

SYMBOL
 Δ Ceramic
 ⊙ Mylar
 □ Non-Inflammable Resistor
 (B,P) Bi-Polar Electrolytic

RESISTORS
 Are in ohms, 1/4 Watts, ±5% Tolerance
 Unless Otherwise Noted K:kΩ, M:MΩ

CAPACITORS
 Are in μF, Unless Otherwise Noted, P:pF

Each D.C. Voltage measured by the instruments described below shows the nominal value in volts at 33 1/3 r.p.m. Measuring instruments. Volt Meter Oscilloscope

E

F

G

H

MOTOR CONTROL (e)

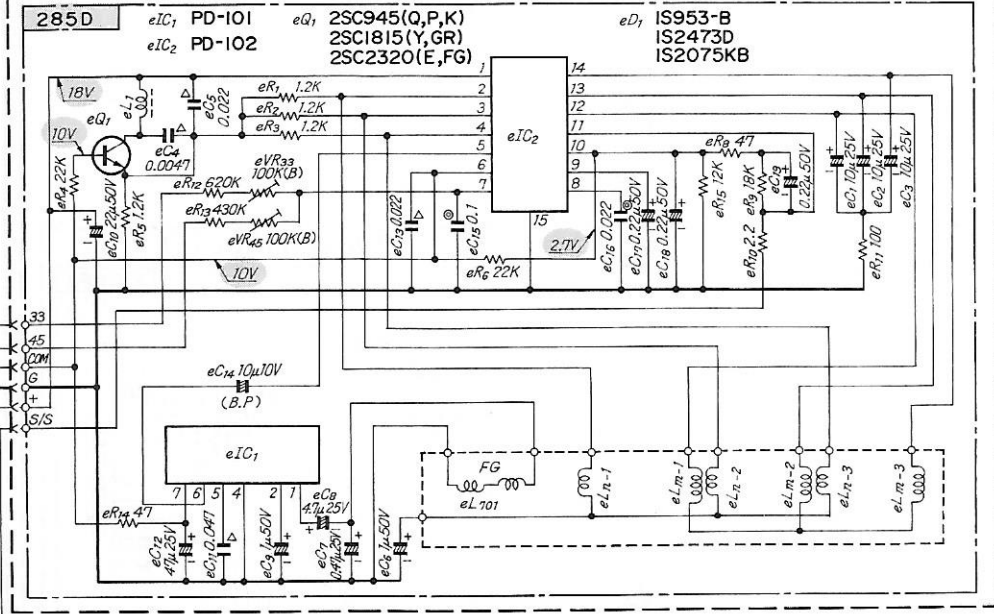

POWER SUPPLY (m)

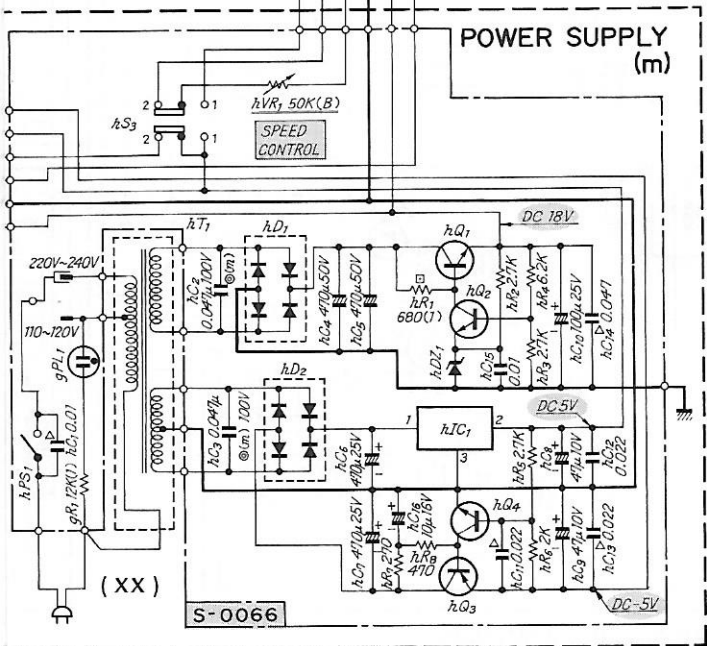

- hQ1 2SC1983
- hQ2 2SC1844(F,E)
- 2SC1735(D,E)
- 2SC1211(D)
- hQ3 2SB527(D,E)
- hQ4 2SA1015(Y,GR)
- 2SA733A(P,Q)
- hD1 RB-152
- hD2 RD5.1E
- hIC1 μ PC78M05H
- FS7805M

SYMBOL OF FUNCTION
 (e) MOTOR-CONTROL
 (f) T.A CONTROL
 (g) INDICATOR
 (h) POWER SUPPLY

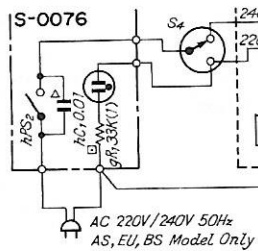
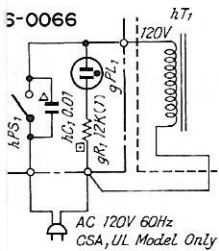
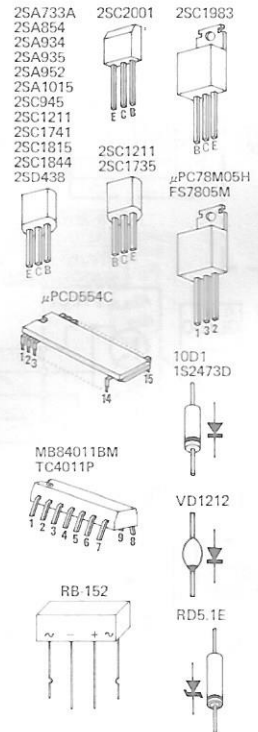

• Note:
 As to C.S.A., U.L., B.S., E.U., A.S. and XX marked in the schematic diagram, note the followings:
 C.S.A., U.L. Circuit in the unit which is applicable to the Canada and U.S.A. under industrial standards.
 B.S. Circuit in the unit which is applicable to British under industrial standards.
 E.U. Circuit in the unit which is applicable to Sweden, Denmark, Norway, Finland, West Germany, and Switzerland under industrial standards.
 A.S. Circuit in the unit which is applicable to Australia under industrial standards.
 XX Circuit in the unit which is applicable to other countries excepting mentioned above.

1

2

3

4

5

8. MAIN PARTS REPLACEMENT (See 5. Exploded View on Page 6)

8-1. Replacement of Tonearm Ass'y (55)

- 1) Remove the bottom cover.
- 2) Loosen 3 screws (7) to remove the mechanism ass'y.
- 3) Loosen the installing screw to remove the TA drum (36).
- 4) Loosen the screw (37) to remove the screen plate (38).
- 5) Remove all lead wires of the tonearm soldered on the terminal board (S-0022).
- 6) The tonearm can be pulled out by loosening the fixing nut.

8-2. Replacement of Clutch Plate (1) (14)

- 1) Perform items 1), 2) "4-1. Replacement of Tonearm Ass'y" first.
- 2) Loosen the screw (12) to remove the clutch plate (2) (13).
- 3) The clutch plate (1) can be taken out.

8-3. Replacement of Plunger Solenoid Ass'y (16)

- 1) Perform items 1), 2) "4-1. Replacement of Tonearm Ass'y" first.
- 2) Loosen the screw (9) to remove the friction disk (10).
- 3) Remove the clutch plate (1), (2).
(See "4-2. Replacement of Clutch Plate (1)".)
- 4) The plunger solenoid ass'y can be taken out by loosening two screws (15).

8-4. Replacement of Gear (1) (21)

- 1) Perform items 1), 2) "Replacement of Tonearm Ass'y" first.
- 2) Remove the friction disk.
(See "4-3. Replacement of Plunger Solenoid Ass'y".)
- 3) Remove the clutch plate (1), (2).
(See "4-2. Replacement of Clutch Plate (1)".)
- 4) Remove the plunger solenoid ass'y.
(See "4-3. Replacement of Plunger Solenoid Ass'y".)
- 5) Remove E type washer (17).
- 6) Remove the gear (2) (18), the plain washer (19), the dumping washer (20).
- 7) The gear (1) can be taken out.

8-5. Replacement of Gear (3) (22)

- 1) Perform items 1), 2) "4-1. Replacement of Tonearm Ass'y" first.
- 2) Remove the plunger solenoid ass'y.
(See 4-3. Replacement of Plunger Solenoid Ass'y".)
- 3) Remove the clutch plate (1), (2).
(See 4-3. Replacement of Clutch Plate (1)".)
- 4) Remove the gear (1).
(See "4-4. Replacement of Gear (1)".)
- 5) Remove E type washer (35).
- 6) The gear (3) can be taken out by removing the friction pulley (25), the spring (23).

8-6. Replacement of Lifter Cam Ass'y (32)

- 1) Perform items 1), 2) "Replacement of Tonearm Ass'y" first.
- 2) Remove E type washer (29).
- 3) Remove the lifter guide (30).
- 4) Remove E type washer (31).
- 5) The lifter cam ass'y can be taken out.

8-7. Note on Parts Replacement

- 1) Refer to Fig. 3-1 (A), (B), and 3-5, when installing screen plate and TA drum.
- 2) When installing the clutch plate (1), fit notch face of the clutch plate (1) to the gear (2).
- 3) When replacing friction pulleys, insert (2) pulleys to gear (3) to face their smoothed surface each other.
- 4) When replacing photo-transistors on the photo-sensor ass'y, attach the photo-transistor so as to meet the center of photo-transistor to the slit of photo-sensor ass'y.
- 5) When installing the plunger solenoid ass'y and the clutch plate (2), adjust the gap of the plunger solenoid so as to be 1.1 mm. (Refer to Fig. 3-5)

* Before replacing a part of the mechanism ass'y, clean it up by the alcohol, especially in friction face.

9. PACKING LIST

Parts No.	Stock No.	Description
1	13040300	Protector Board, upper
2	70122210	Dust Cover Ass'y
3	91122500	Polyethylene Bag, dust cover
4	13035800	Protector Board, platter
5	13036400	Rubber Mat
6	13040000	Turntable Platter
7	91166000	Polyethylene Bag, turntable
8	91122710	Polyethylene Bag, turntable unit
9	13057500	Styrofoam Packing, front
10	13057600	Styrofoam Packing, rear
11	13040200	Accessory Box
12	13049200	Carton Case

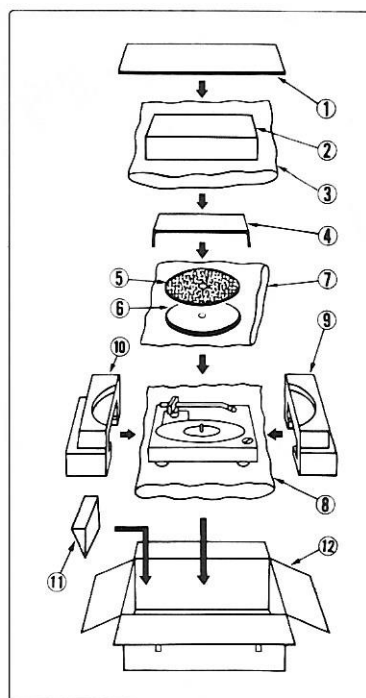

10. ACCESSORY LIST

Parts No.	Stock No.	Description
	13074600	Sub Weight Ass'y
	13012300	EP Adaptor
	13043100	Head Shell
	43103700	Cartridge Ass'y, SC-50
	49402300	Stylus, SN-50
*	13010800	Cartridge Ass'y, SV-101
	13010900	Stylus, SN-101
	13073600	Cartridge Ass'y, SV-202
	13073800	Stylus, SN-202
	13044600	Auto Hinge, dust cover
	07643400	Operating Instruction

*** Note :**

There are two types of units in FR-D45.

1) The unit with a cartridge (SC-50, SV-101 or SV-202).

2) The unit without a cartridge.

The mark (E) is stamped on the side of carton case.

- In particular area, either type of these unit is sold.



SANSUI ELECTRIC COMPANY LTD.:
SANSUI ELECTRONICS CORPORATION:

SANSUI ELECTRONICS (U.K.) LTD.:
SANSUI ELECTRONICS G.M.B.H.:

14-1, Izumi 2-chome, Suginami-ku, Tokyo 168 Japan PHONE:(03) 323-1111/TELEX:232-2076
1250 Valley Brook Ave. Lyndhurst, N.J. 07071 U.S.A.
333 West Alondra Blvd. Gardena, California 90247 U.S.A.
3036 Koapaka St. Honolulu, Hawaii 96819 U.S.A.
Unit 10A, Lyon Industrial Estate, Rockware Avenue, Greenford, Middx UB6, OAA, England
Arabella center, 6 Frankfurt AM Main, Lyoner Strasse 44-48, West Germany