

• STK4162-MK2 <Power Amp>

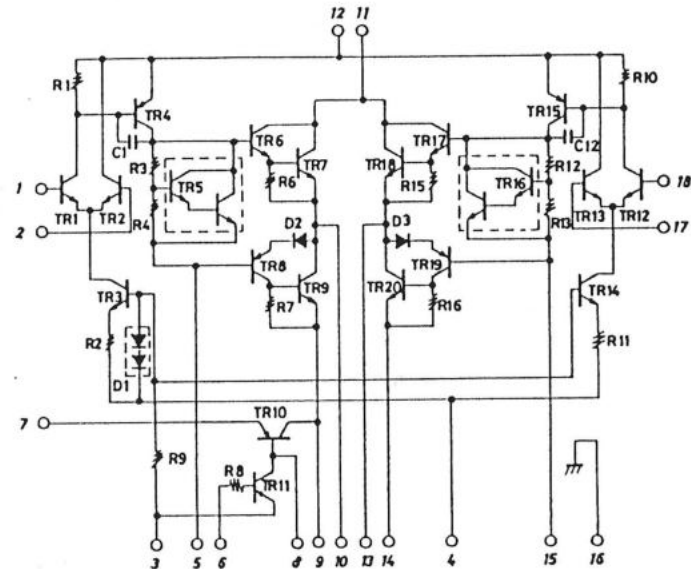

• LB1641 <Motor Drive>

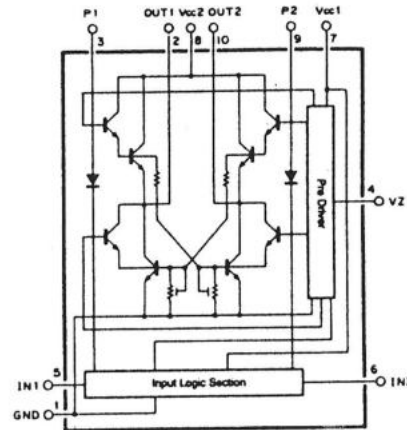

MC-X5 MC-X5L

MINI COMPONENT SYSTEM
<AMPLIFIER SECTION>

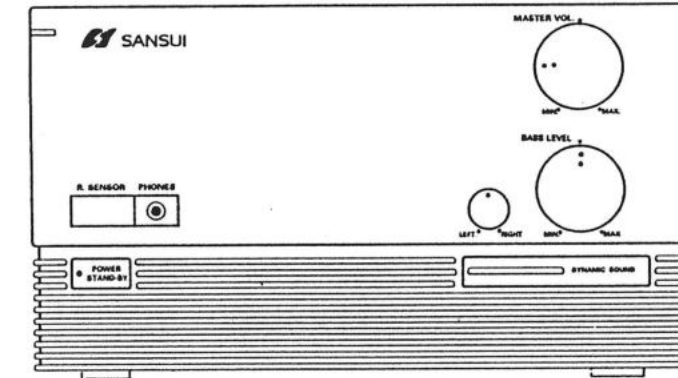

• TA7317P <Protector>

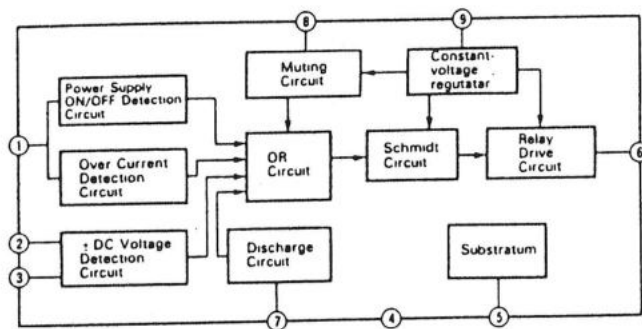

Organization of System Component

	Amplifier	Tuner	CD Player	Cassette Deck	Speaker
SET NAME	A-X5	T-X7, T-X7L	CD-X7	D-X7	S-X5

Note: Set name is shown on the rear panel.

CAUTION

- Parts identified by the Δ symbol on the schematic diagram and the parts list are critical for safety. Use only replacement parts that have critical characteristics recommended by the manufacturer.
- Make leakage-current or resistance measurements to determine that exposed parts are acceptably insulated from the supply circuit before returning the appliance to the customer.

NOTICE

- Some printed circuit boards are not supplied assembled. To separate these in this Service Manual, the stock numbers are not indicated for these boards. However, stock numbers for individual parts are indicated.
- The symbols, UL, EU, EG, UK, SEV, SS and XX <EXPORT> on the Part List and the schematic diagram mean followings respectively.
 UL Manufactured for U.S.A. market.
 (Underwriters Laboratories approved model.)
 EU Manufactured for European market.
 EG Manufactured for F.R. Germany market.
 UK Manufactured for United Kingdom market.
 SEV Manufactured for Swiss market.
 SS Manufactured for Saudi Arabian market.
 XX Standard Version.
 <EXPORT>
 NON MARK Common Parts.
- Since some capacitors and resistors are omitted from parts lists in this Service Manual, refer to the Common Parts List for capacitors and resistors, which was issued on June 1987.
- Abbreviations in this Parts List are as follows.

•Abbreviations List

C.R.	: Carbon Resistor	E.B.L.	: Low Leak Bi-Polar Electrolytic Capacitor
S.R.	: Solid Resistor	Ta.C.	: Tantalum Capacitor
Ce.R.	: Cement Resistor	F.C.	: Film Capacitor
M.R.	: Metal Film Resistor	M.P.	: Metalized Paper Capacitor
F.R.	: Fusing Resistor	P.C.	: Polystyrene Capacitor
N.I.R.	: Non-Inflammable Resistor	M.M.C.	: Metalized Mylar Capacitor
A.R.	: Array Resistor	A.C.	: Array Capacitor
C.C.	: Ceramic Capacitor	V.R.	: Variable Resistor
C.T.	: Ceramic Capacitor, Temperature Compensation	S.V.R.	: Semi Variable Resistor
E.C.	: Electrolytic Capacitor	SW.	: Switch
E.L.	: Low Leak Electrolytic Capacitor	Chip R.	: Chip Resistor
E.B.	: Bi-Polar Electrolytic Capacitor	Chip C.	: Chip Capacitor



SANSUI ELECTRIC CO., LTD.:

SANSUI USA INC.:

SANSUI DEUTSCHLAND G.M.B.H.:

山水電気株式会社

New River Bldg. 10-14, Shinkawa 1-chome, Chuo-ku, Tokyo 104, Japan
 PHONE: (03) 5566-1024 / FAX: 03-5566-1027 (International Division)
 1290 Wall Street West, Lyndhurst, New Jersey 07071 U.S.A.
 17150 South Margay Ave. Carson, California 90746 U.S.A.
 Paul-Ehrlich-Strasse 8, 6074 Rödermark 2, F. R. Germany

東京都中央区新川1-10-14 (〒104)

Specifications

[Amplifier]

Power output
Min. RMS, both channels driven, from 20 to 20,000 Hz, with no more than 0.7% total harmonic distortion. 40 watts per channel into 6 ohms.

DIN
45 watts per channel into 6 ohms.
Load impedance 6 ohms

Frequency response (at 1 watt)
AV/DAT(PLAY) 10 to 50,000 Hz, +1 dB, -3 dB
Input sensitivity and impedance (at 1 kHz)
AV/DAT(PLAY) 200 mV/47 kohms
Signal to noise ratio (short-circuit, A-network)
AV/DAT(PLAY) 90 dB
Dynamic sound (MASTER VOLUME -30dB)
..... +9 dB (80 Hz)
Dimensions 225 mm (8-7/8") W
126 mm (5") H
340 mm (13-7/16") D
Weight 5.2 kg (11.46 lbs) net

[Others]

Power requirements AC 120 V/220 V (50/60 Hz)
For U.S.A. & Canada AC 120 V (60 Hz)
For European AC 220 V (50 Hz)
Power consumption 155 watts 165 VA
For European 220 Watts

* Design and specifications subject to changes without notice for improvements.
* Due to local laws and regulations, this unit sold in some areas are not equipped with variable voltage selectors.

1. PIN LOCATION OF SYSTEM CONTROL SOCKET

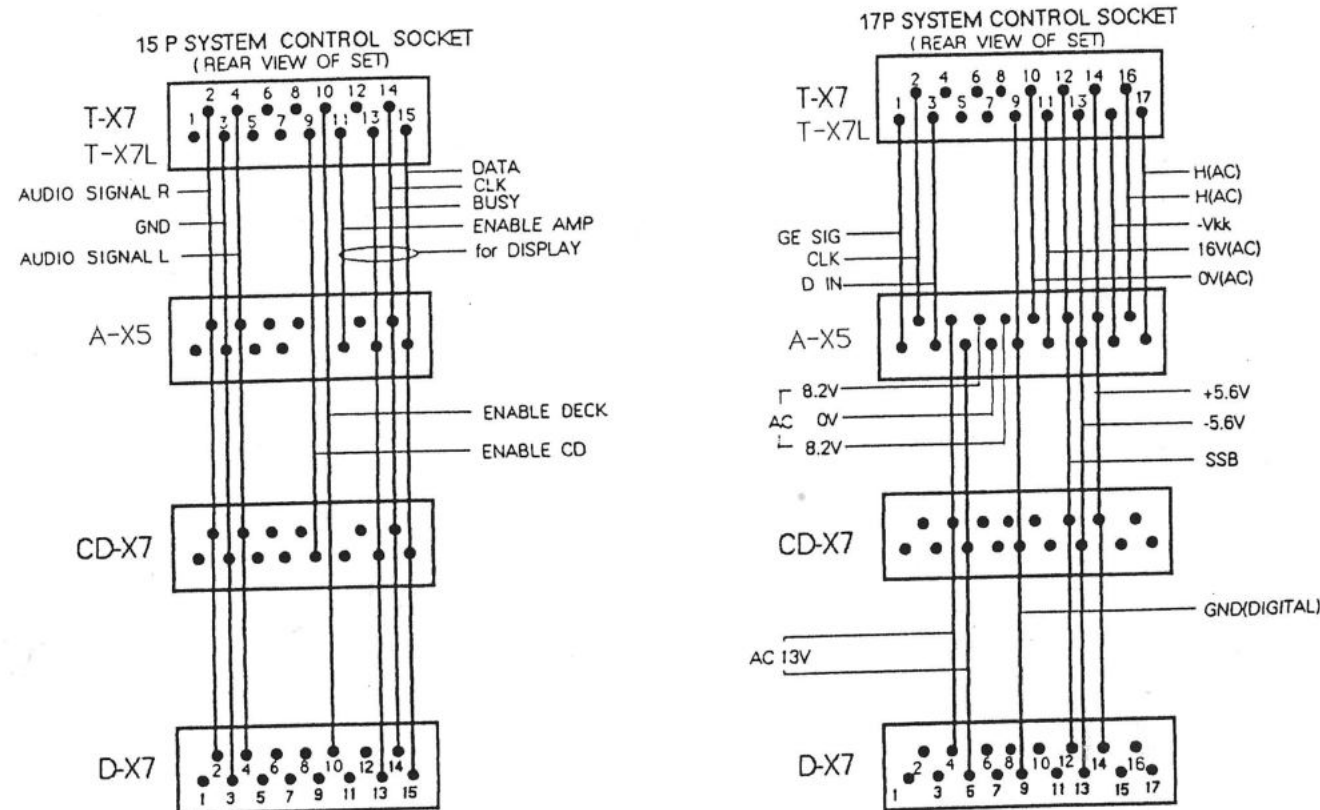

3. PARTS LIST OF BOARD

3-1. F-6615 Power Amp Board <Stock No. 01257601>

Parts No.	Stock No.	Description
•IC		
Δ kIC1	49632300	STK4162-MK2
	kC11	48102600 22μF 25V E.B.
Δ kR5	46230600	2.2kΩ 1/2W N.I.R.
Δ kR6	46230600	2.2kΩ 1/2W N.I.R.
Δ kR7	46229000	100Ω 1/2W N.I.R.
Δ kR8	46230200	1kΩ 1/2W N.I.R.
Δ kR9	46229000	100Ω 1/2W N.I.R.
Δ kR10	46230200	1kΩ 1/2W N.I.R.
Δ kR11	46248100	10Ω 1W N.I.R.
•Transistor		
IQ1	46719800	DTA124ES
IQ2	46604301	2SC3327
IQ4	46947301	2SA1049
IQ5	46367101	2SC2603
	or 46367301	2SC2458
IQ7	46719900	DTC124ES
IQ8	48229600	DTA114ES
	or 49390300	RN2202
•IC		
IIC1	46207600	TA7317P
•Diode		
ID1-2	46464100	1SS133
ID4-6	46464100	1SS133
Δ IR15	46905800	0.22Ω 3W N.I.R.
	IC11	48101500 100μF 6.3V E.B.
	IRL1	48183100 Relay (DC24V)
	or 49658800	Relay (DC24V)
•Transistor		
Δ mQ1	48508801	2SC3851
	or 48509401	2SD1761
Δ mQ2	46188701	2SC1815
	or 46367101	2SC2603
Δ mQ3	48063301	2SB507
•IC		
Δ mIC1	49319100	μPC78M12HF
	or 49440800	NJM78M12FA
Δ mIC2	49435600	NJM79M12FA
Δ mIC3	49319100	μPC78M12HF
	or 49440800	NJM78M12FA
Δ mIC5	46359400	L78N05
Δ mIC6	49474700	NJM7905FA
•Diode		
Δ mD1	49634100	DBF60E
mD3	46464100	1SS133
Δ mD5	03117000	RB152-LFF
Δ mD7	46273600	DBB10B
Δ mD8	46273600	DBB10B
mD9	46464100	1SS133
•Zener Diode		
mDZ2	49516800	MTZJ30B
	or 49516900	MTZJ30C
	or 49517000	MTZJ30D

<F-6615>

Parts No.	Stock No.	Description
mDZ3	03168700	RD 5.6F B
	or 03168800	RD 5.6F B3
mDZ5	48637500	RD24B4 ES
	or 49516200	MTZJ24D
Δ mR1	46622700	4.7Ω 2W N.I.R.
Δ mR2	46625000	390Ω 2W N.I.R.
Δ mR3	46230700	2.7kΩ 1W N.I.R.
Δ mR4	46401600	4.7Ω 1/2W N.I.R.
Δ mR9, 10	46401600	4.7Ω 1/2W N.I.R.
Δ mR12	46401600	4.7Ω 1/2W N.I.R.
Δ mR13	46230800	3.3kΩ 1/2W N.I.R.
Δ mR14	46401600	4.7Ω 1/2W N.I.R.
mC1, 2	49114600	6800μF 50V E.C.
mC16-18	08680400	0.01μF 500V C.C.
mC19	49417000	0.1μF 50V C.C.
mC28	08680400	0.01μF 500V C.C.
oZ4	49352400	15P FG System Control Socket

3-2. F-6616 Speaker Terminal Board

Parts No.	Stock No.	Description
•Diode		
mD6	46464100	1SS133
Δ mRL1	48340300	Relay (DC12V)
	or 48982000	Relay (DC12V)
	oZ1	49632700 4P Speaker Terminal
Δ pC1	46425800	0.01μF 400V C.C.
	or 48186700	0.01μF 400V C.C.
	or 49538100	0.01μF 400V C.C.
Δ pS1	49614100	Slide SW., Voltage Selector(X)
Δ pS2	49614100	Slide SW., Voltage Selector(X)
Δ pF1	49593800	Fuse 3.15A (UL)
	49297100	Fuse 1.6A (EU-EG-SEV)
	49593500	Fuse 1.6A (XX-SS)
	49593500	Fuse 1.6A (XX-SS)
	49297100	Fuse 1.6A (UK)
Δ pR1	00048100	3.3MΩ 1/2W S.R. (UL)

3-3. F-6618 System Control Terminal Board

Parts No.	Stock No.	Description
	oZ3	49587300 17P FG System Control Socket

3-4. F-6619 Headphone Jack Board

Parts No.	Stock No.	Description
Δ kR19	46624700	220Ω 2W N.I.R.
	oJ1	49600600 Jack, Phone

Specifications

[Amplifier]

Power output
Min. RMS, both channels driven, from 20 to 20,000 Hz, with no more than 0.7% total harmonic distortion. 40 watts per channel into 6 ohms.

DIN
45 watts per channel into 6 ohms.
Load impedance 6 ohms

Frequency response (at 1 watt)
AV/DAT(PLAY) 10 to 50,000 Hz, +1 dB, -3 dB
Input sensitivity and impedance (at 1 kHz)
AV/DAT(PLAY) 200 mV/47 kohms
Signal to noise ratio (short-circuit, A-network)
AV/DAT(PLAY) 90 dB

Dynamic sound (MASTER VOLUME -30dB)
..... +9 dB (80 Hz)
Dimensions 225 mm (8-7/8") W
126 mm (5") H
340 mm (13-7/16") D
Weight 5.2 kg (11.46 lbs) net

[Others]

Power requirements AC 120 V/220 V (50/60 Hz)
For U.S.A. & Canada AC 120 V (60 Hz)
For European AC 220 V (50 Hz)
Power consumption 155 watts 165 VA
For European 220 Watts

* Design and specifications subject to changes without notice for improvements.
* Due to local laws and regulations, this unit sold in some areas are not equipped with variable voltage selectors.

1. PIN LOCATION OF SYSTEM CONTROL SOCKET

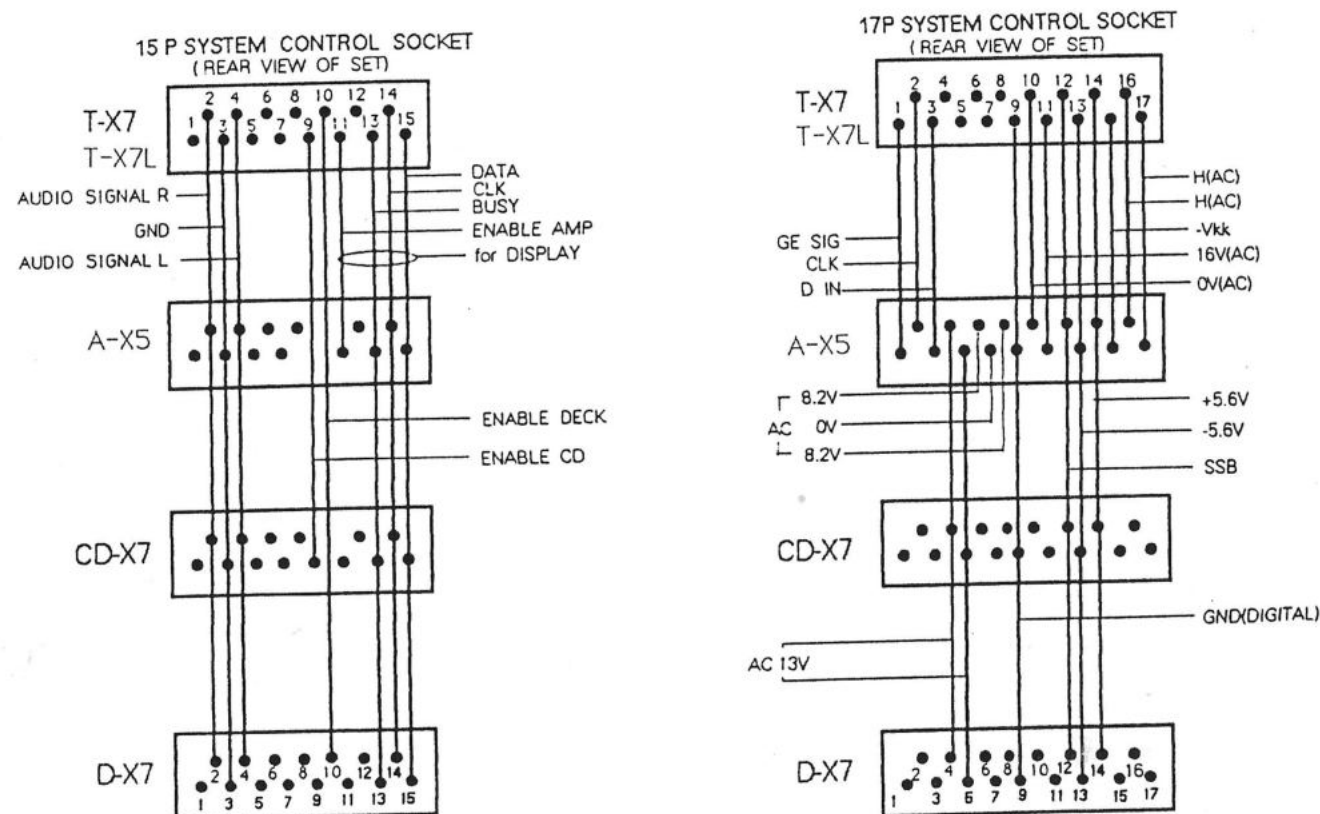

2 3. PARTS LIST OF BOARD

3-1. F-6615 Power Amp Board

<Stock No. 01257601>

Parts No.	Stock No.	Description
•IC		
Δ kIC1	49632300	STK4162-MK2
	kC11	48102600 22μF 25V E.B.
Δ kR5	46230600	2.2kΩ 1/2W N.I.R.
Δ kR6	46230600	2.2kΩ 1/2W N.I.R.
Δ kR7	46229000	100Ω 1/2W N.I.R.
Δ kR8	46230200	1kΩ 1/2W N.I.R.
Δ kR9	46229000	100Ω 1/2W N.I.R.
Δ kR10	46230200	1kΩ 1/2W N.I.R.
Δ kR11	46248100	10Ω 1W N.I.R.
•Transistor		
IQ1	46719800	DTA124ES
IQ2	46604301	2SC3327
IQ4	46947301	2SA1049
IQ5	46367101	2SC2603
	or 46367301	2SC2458
IQ7	46719900	DTC124ES
IQ8	48229600	DTA114ES
	or 49390300	RN2202
•IC		
IIC1	46207600	TA7317P
•Diode		
ID1-2	46464100	1SS133
ID4-6	46464100	1SS133
Δ IR15	46905800	0.22Ω 3W N.I.R.
IC11	48101500	100μF 6.3V E.B.
IRL1	48183100	Relay (DC24V)
	or 49658800	Relay (DC24V)
•Transistor		
Δ mQ1	48508801	2SC3851
	or 48509401	2SD1761
Δ mQ2	46188701	2SC1815
	or 46367101	2SC2603
Δ mQ3	48063301	2SB507
•IC		
Δ mIC1	49319100	μPC78M12HF
	or 49440800	NJM78M12FA
Δ mIC2	49435600	NJM79M12FA
Δ mIC3	49319100	μPC78M12HF
	or 49440800	NJM78M12FA
Δ mIC5	46359400	L78N05
Δ mIC6	49474700	NJM7905FA
•Diode		
Δ mD1	49634100	DBF60E
mD3	46464100	1SS133
Δ mD5	03117000	RB152-LFF
Δ mD7	46273600	DBB10B
Δ mD8	46273600	DBB10B
mD9	46464100	1SS133
•Zener Diode		
mDZ2	49516800	MTZJ30B
	or 49516900	MTZJ30C
	or 49517000	MTZJ30D

<F-6615>

Parts No.	Stock No.	Description
mDZ3	03168700	RD 5.6F B
	or 03168800	RD 5.6F B3
mDZ5	48637500	RD24B4 ES
	or 49516200	MTZJ24D
Δ mR1	46622700	4.7Ω 2W N.I.R.
Δ mR2	46625000	390Ω 2W N.I.R.
Δ mR3	46230700	2.7kΩ 1W N.I.R.
Δ mR4	46401600	4.7Ω 1/2W N.I.R.
Δ mR9, 10	46401600	4.7Ω 1/2W N.I.R.
Δ mR12	46401600	4.7Ω 1/2W N.I.R.
Δ mR13	46230800	3.3kΩ 1/2W N.I.R.
Δ mR14	46401600	4.7Ω 1/2W N.I.R.
mC1, 2	49114600	6800μF 50V E.C.
mC16-18	08680400	0.01μF 500V C.C.
mC19	49417000	0.1μF 50V C.C.
mC28	08680400	0.01μF 500V C.C.
oZ4	49352400	15P FG System Control Socket

3-2. F-6616 Speaker Terminal Board

Parts No.	Stock No.	Description
•Diode		
mD6	46464100	1SS133
Δ mRL1	48340300	Relay (DC12V)
Δ	or 48982000	Relay (DC12V)
oZ1	49632700	4P Speaker Terminal
Δ pC1	46425800	0.01μF 400V C.C.
Δ	or 48186700	0.01μF 400V C.C.
Δ	or 49538100	0.01μF 400V C.C.
Δ pS1	49614100	Slide SW., Voltage Selector(X)
Δ pS2	49614100	Slide SW., Voltage Selector(X)
Δ pF1	49593800	Fuse 3.15A (UL)
Δ	49297100	Fuse 1.6A (EU-EG-SEV)
Δ	49593500	Fuse 1.6A (XX-SS)
Δ pF2	49593500	Fuse 1.6A (XX-SS)
Δ	49297100	Fuse 1.6A (UK)
Δ pR1	00048100	3.3MΩ 1/2W S.R. (UL)

3-3. F-6618 System Control Terminal Board

Parts No.	Stock No.	Description
oZ3	49587300	17P FG System Control Socket

3-4. F-6619 Headphone Jack Board

Parts No.	Stock No.	Description
Δ kR19	46624700	220Ω 2W N.I.R.
oJ1	49600600	Jack, Phone

4. PARTS LOCATION ON BOARD

4-1. F-6615 Power Amp Board
Component Side

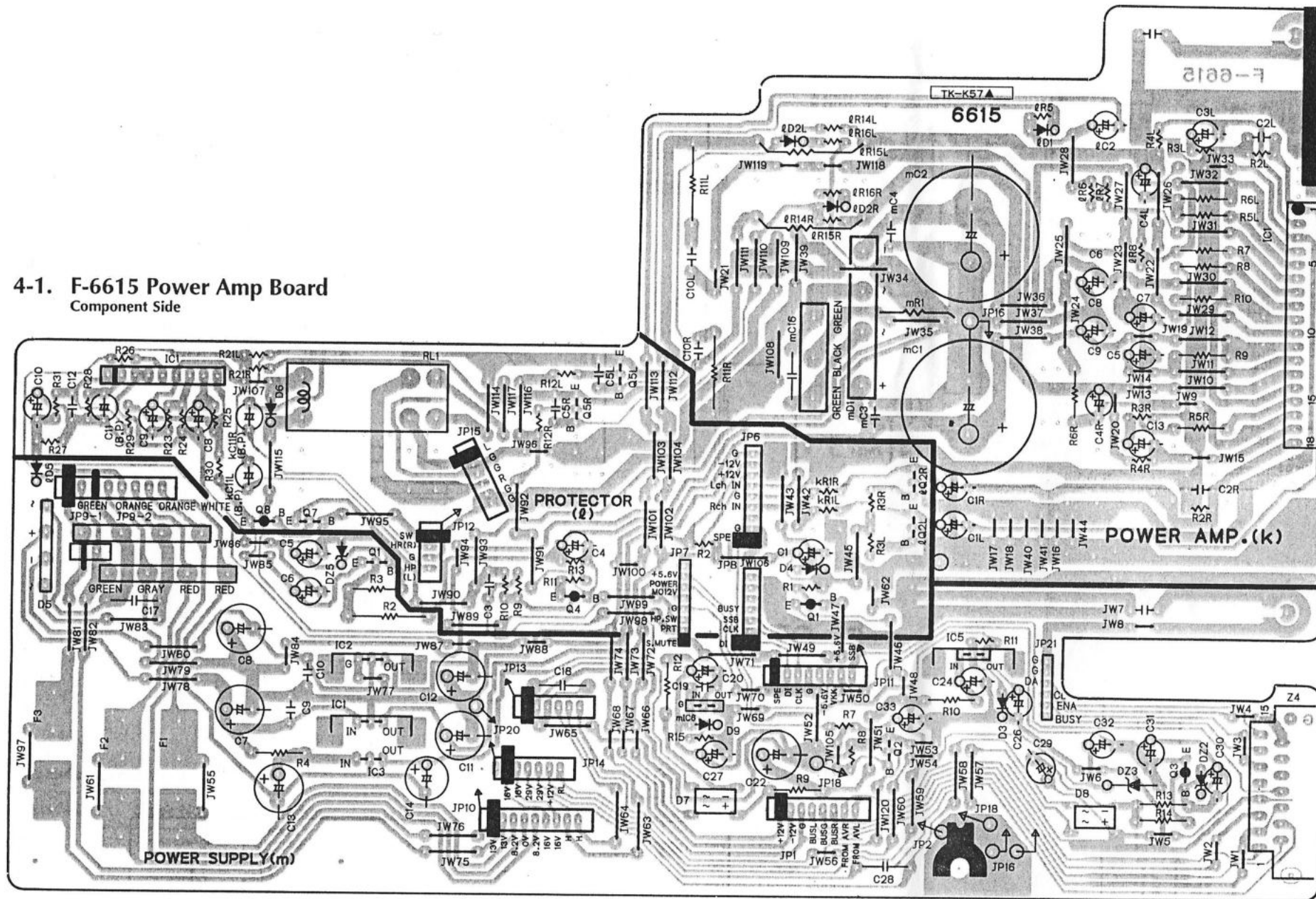

4-2. F-6617 Power Transformer
Connection Board
Component Side

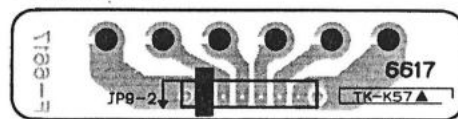

4-3. F-6618 System
Control Terminal Board
Component Side

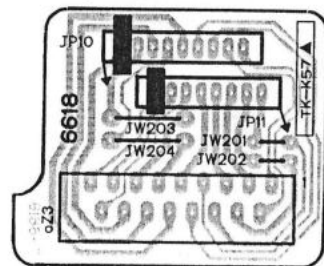

4-4. F-6619 Headphone Jack Board
Component Side

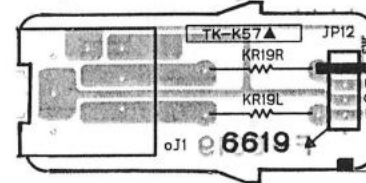

4-5. F-6616 Speaker Terminal Board
Component Side

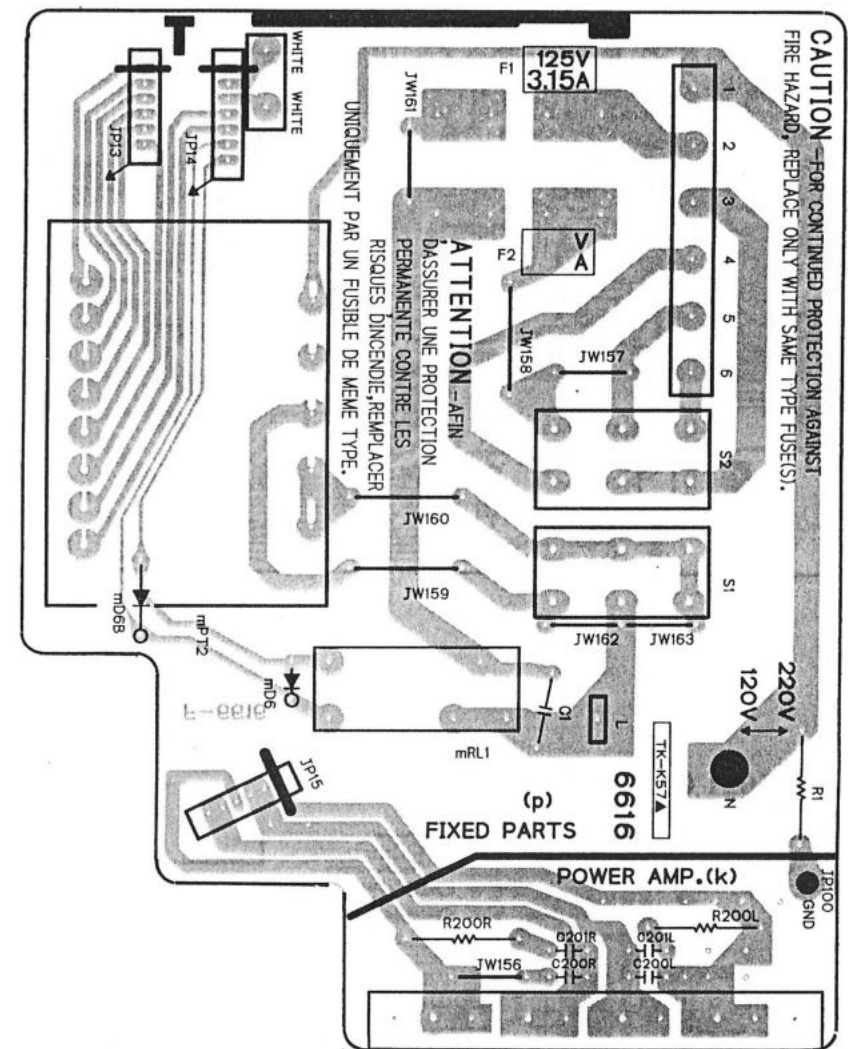

4-6. F-6622 Volume Board
Component Side

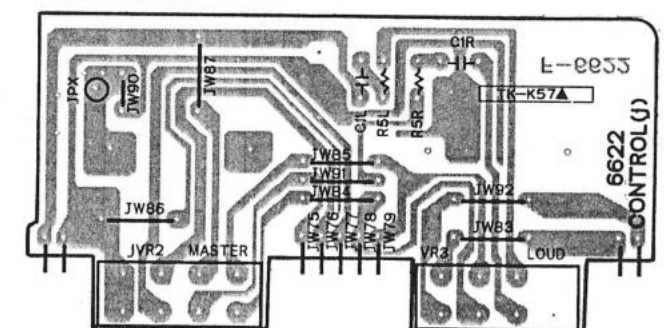

3-5. F-6620 Selector Board

<Stock No. 01258101>

Parts No.	Stock No.	Description
•IC		
jIC3	03607700	NJM4558D
	or 49541300	M5218AP
jIC4	49298100	LC7522
jIC5	49557300	M5229P
•Diode		
jD1	03117600	1S2473
•Zener Diode		
jDZ1, 2	48552200	MTZ5.1C
Δ jR22	46405200	4.7kΩ 1/2W N.I.R.
Δ jR23	46405000	3.3kΩ 1/2W N.I.R.
jR27	46350500	100kΩx8 1/8W A.R.
jC17	48812900	0.68μF 50V E.B.
jC18	48812700	0.33μF 50V E.B.
jC19	48812600	0.22μF 50V E.B.
jC30	48299800	1500pF 50V C.C.
jC31	48299400	1000pF 50V C.C.
jC37	48297000	100pF 50V C.C.
•Transistor		
oQ1	46604301	2SC3327
oQ2	46367001	2SA1115
	or 46367201	2SA1048
oQ3	46834300	DTC144ES
•IC		
oIC1, 2	03607700	NJM4558D
	or 49541300	M5218AP
oIC3	48056800	LC4966
•Diode		
oD1	46464100	1SS133
•Zener Diode		
oDZ1	48553700	MTZ8.2C
oZ2	49584800	4P Terminal, AV/DAT (REC, PLAY)

3-6. F-6621 Control Board

<Stock No. 01258201>

Parts No.	Stock No.	Description
•IC		
jIC1	03607700	NJM4558D
	or 49541300	M5218AP
jVR1	49600100	250kΩ(W) V.R., BALANCE
•LED		
nLD1	48841400	SEL3213C, DYNAMIC SOUND
nLD4	49378800	SEL2210S, POWER STAND-BY
nLD5	48841400	SEL3213C, POWER
oIC7	49356200	Remote Receive Unit GP1U521X
•Transistor		
oQ4	48171600	DTC114YS
oQ5	46719900	DTC124ES
oQ6	48171600	DTC114YS
oQ7	46719800	DTA124ES
oQ8	48217800	DTC114ES
oQ9	48171600	DTC114YS

<F-6621>

Parts No.	Stock No.	Description
•IC		
oIC4	48982600	LB1641
oIC6	49633100	TMP47C860N-P155
oXO1	49357500	Quartz Element CST6.00MGW
•Diode		
oD2, 3	46464100	1SS133
•Zener Diode		
oDZ2	48628400	RD2.7B1 ES
oC6	49428800	10000pF 16V C.C.
oC10	48717800	4700μF 5.5V E.C.
oC11	49430000	0.1μF 16V C.C.
oC18	49417000	0.1μF 50V C.C.
oS2	49326300	Push SW., POWER STAND-BY
oS3	48832900	Push SW., RESET
oS4	48372900	Push SW., DYNAMIC SOUND

3-7. F-6622 Volume Board

Parts No.	Stock No.	Description
jVR2	49584900	150kΩ (B) V.R. With Motor, MASTER VOLUME
jVR3	49632800	150kΩ (B) V.R., BASS LEVEL VOLUME

3-8. F-6623 Volume Terminal Connection Board

Parts No.	Stock No.	Description
oC5	49430000	0.1μF 16V C.C.

3-9. F-6624 Bass Level Volume Indicator Board

Parts No.	Stock No.	Description
•LED		
nLD2	48841100	SEL3210S, BASS LEVEL VOLUME

3-10. F-6625 Master Volume Indicator Board

Parts No.	Stock No.	Description
•LED		
nLD3	48841100	SEL3210S, MASTER VOLUME

4-7. F-6620 Selector Board

Component Side

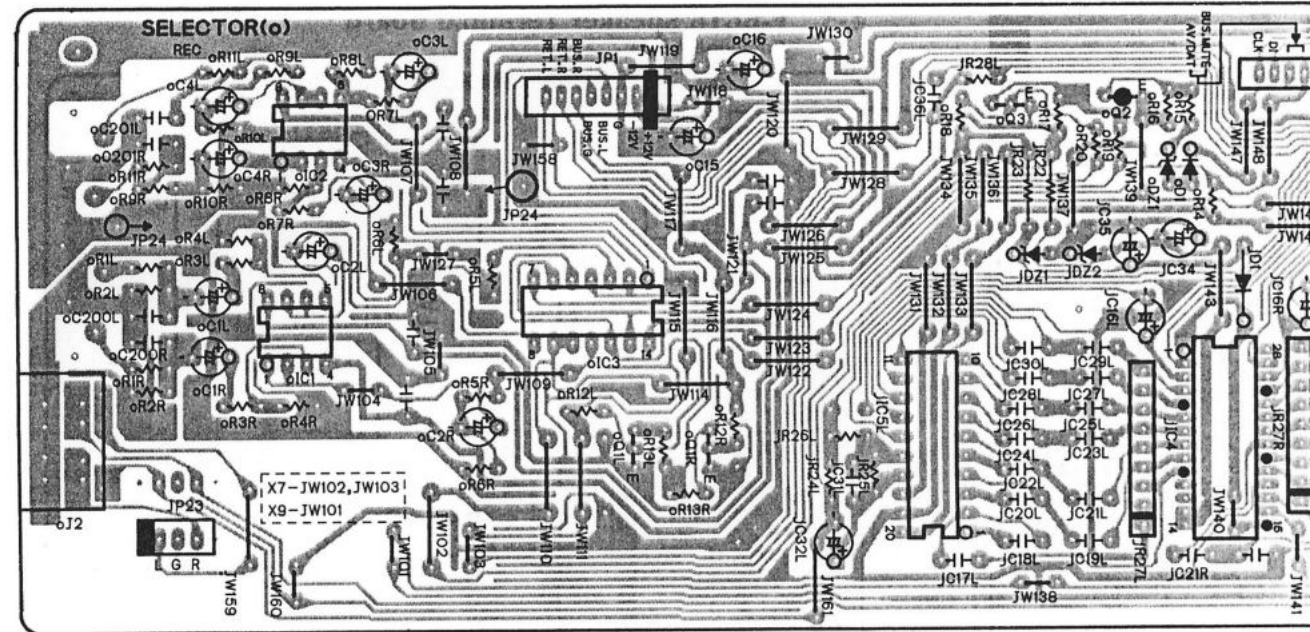

4-8. F-6621 Control Board

Component Side

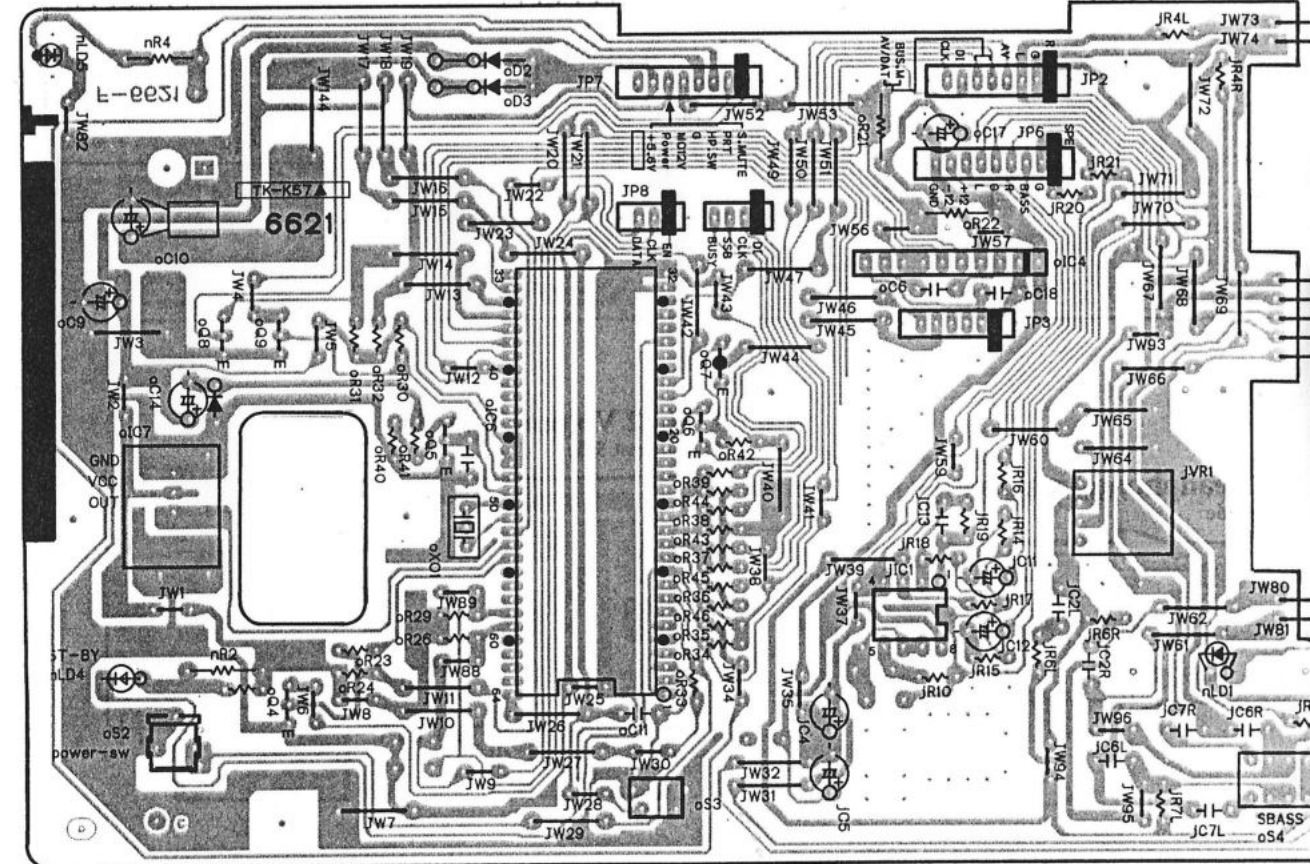

4

4

5

4-9. F-6623 Volume Terminal Connection Board
Component Side

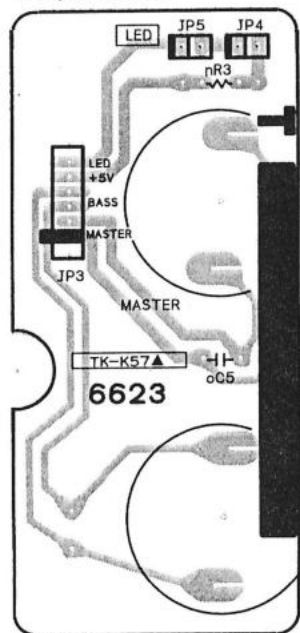
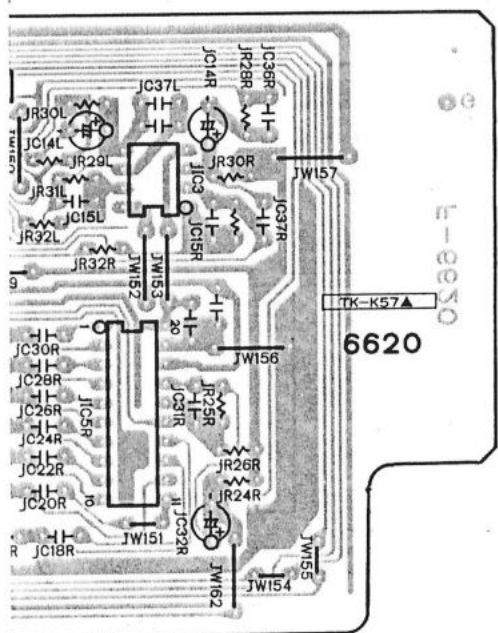

4-10. F-6624 Bass Level Volume Indicator Board
Component Side

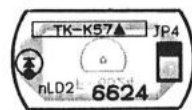

4-11. F-6625 Master Volume Indicator Board
Component Side

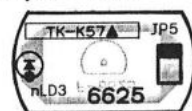

5. OTHER PARTS

<Front View>

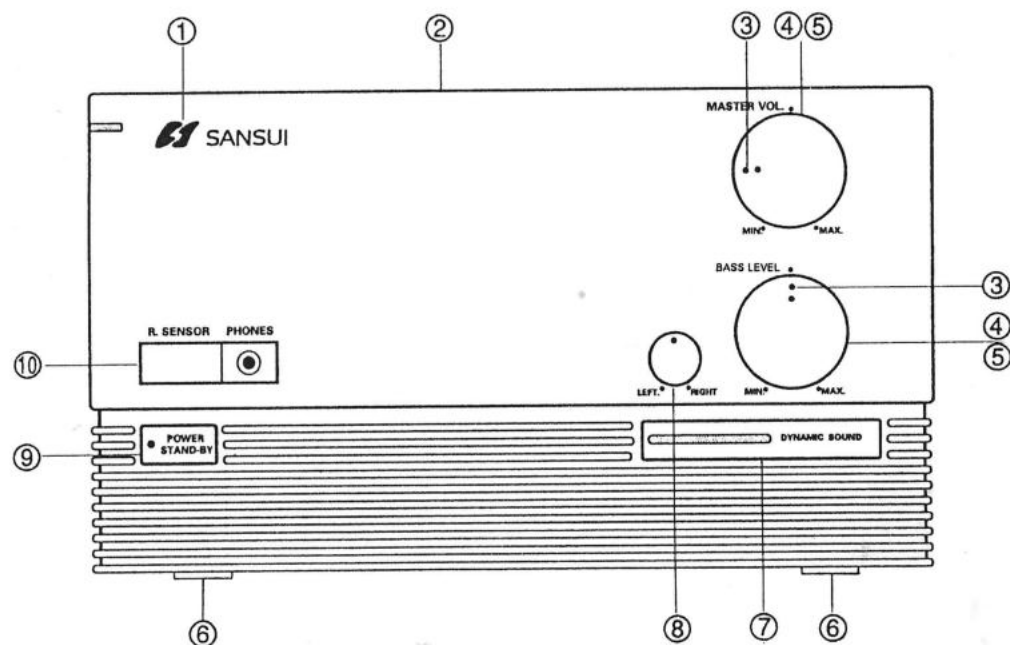

<Top View>

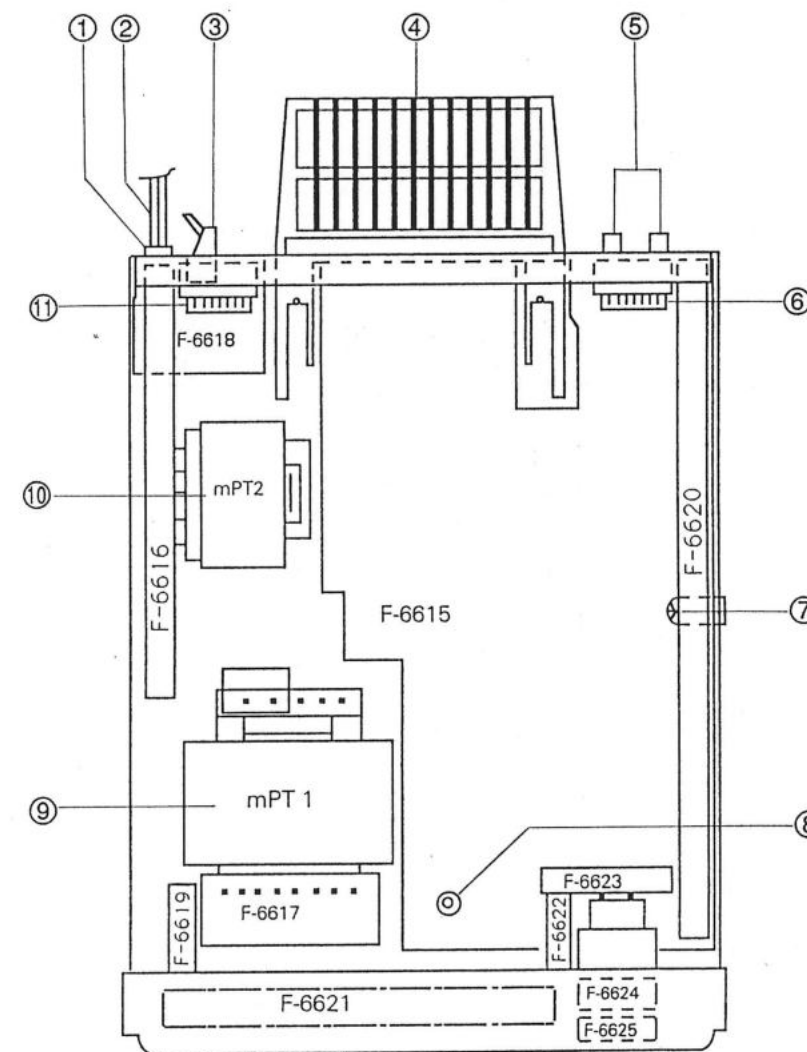

Parts List <Front View>

Parts No.	Stock No.	Description
1	27925600	Front Panel Ass'y (MC-X5)
	27925700	Front Panel Ass'y (MC-X5L)
2	05027000	Bonnet
3	27899200	VR Indicator
4	27924700	Knob, MASTER-BASS LEVEL
5	07105600	Nut, ø7.0
6	27902510	Leg Sheet
7	27925100	Knob Ass'y, DYNAMIC SOUND
8	27924600	Knob, BALANCE
9	27925000	Knob Ass'y, POWER STAND-BY
10	27898700	RS Filter

Parts List <Top View>

Parts No.	Stock No.	Description
1	49374300	Strain Relief
△ 2	46407700	Power Supply Cord (XX)
△	48188000	Power Supply Cord (UL)
△	49299300	Power Supply Cord (EU-EG)
△	48837700	Power Supply Cord (SS)
△	49252900	Power Supply Cord (UK)
△	48306700	Power Supply Cord (SEV)
3	49632700	4P Speaker Terminal
4	27899700	Heat Sink Cover
5	49584800	4P Terminal, AV/DAT (REC, PLAY)
6	49352400	15P FG System Control Socket, SYSTEM CONTROL 1
7	49571500	PC Support-8R
8	49571700	PC Support-12R
△ 9	15039401	Power Transformer, mPT1 (XX-SS)
△	15039402	Power Transformer, mPT1 (UL)
△	15039405	Power Transformer, mPT1 (EU-UK-EG-SEV)
△ 10	15038901	Power Transformer, mPT2 (XX-SS)
△	15038902	Power Transformer, mPT2 (UL)
△	15038905	Power Transformer, mPT2 (EU-UK-EG-SEV)
11	49587300	17P FG System Control Socket, SYSTEM CONTROL 2

6. PACKING & ACCESSORY LIST

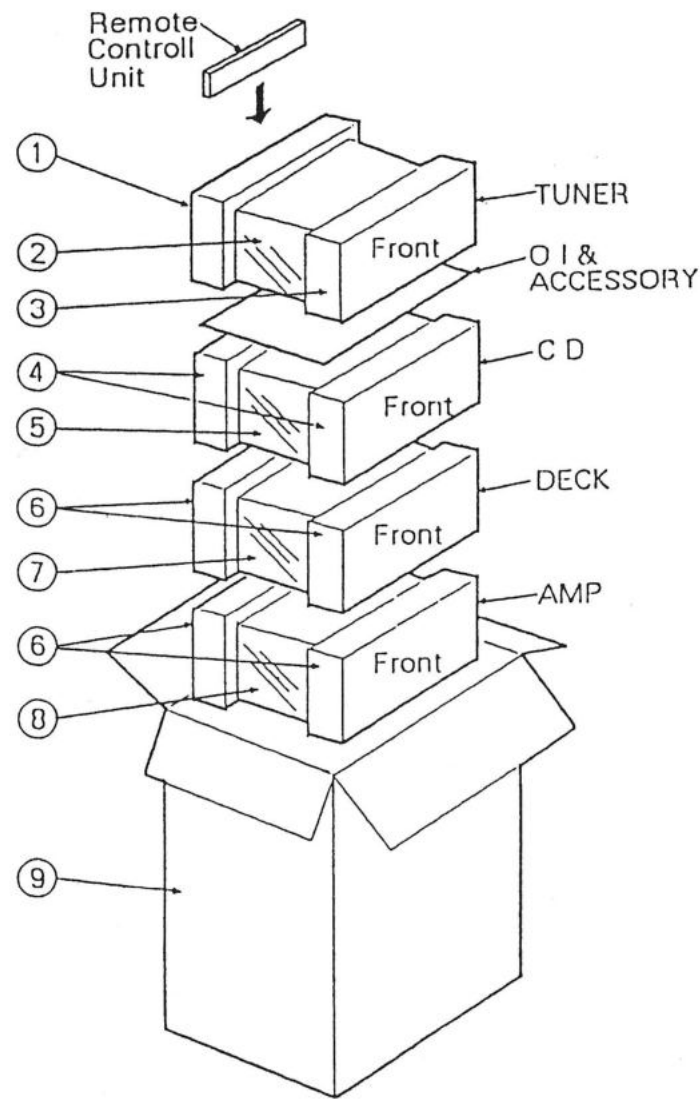

Packing List

Parts No.	Stock No.	Description
1	27903400	Styrofoam Packing, Tuner (R)
2	27867300	Vinyl Bag, Tuner
3	27903300	Styrofoam Packing, Tuner (F)
4	27903500	Styrofoam Packing, CD (Pair)
5	27867400	Vinyl Bag, CD
6	27903200	Styrofoam Packing, Deck/AMP (Pair)
7	27594000	Vinyl Bag, Deck
8	27343800	Vinyl Bag, AMP
9	05068700	Carton Case (MC-X5)
	05068800	Carton Case (MC-X5L)

Accessory List

Parts No.	Stock No.	Description
	49661300	Remote Controller, RS-F22
		Dry Battery, SUM-3
	49631200	AM Loop Antenna
	49335000	Antenna Matching Transformer (MC-X5L)
	46051700	FM Antenna Wire
	07563000	Antenna Holder Ass'y
	49592410	17P FG Connector Cable (E)
	49592510	15P FG Connector Cable (F)
	19074100	Operating Instructions (E, F, S)
	19074200	Operating Instructions (H, G, I, Sw)

*Note

E-F-S: English-French and Spanish Version
H-G-I-Sw: Hollands-German-Italian and Swedish Version

7. REPLACEMENT OF MAIN PARTS

A. How to Remove the Front Panel Ass'y (See Figs.7-1 ~ 7-3)

1. Remove the bonnet.
2. Remove a screw and remove the PC holder ③ that fixes the F-6620.
3. Remove the two screws ④ underneath the front panel.
4. Remove the master, bass and balance knob ⑤.
5. Remove the F-6625 and F-6624 from the VR shaft and remove the VR setting nut M7 ⑥.
6. Remove the F-6620 setting screw ⑦ in the rear panel side.
7. Remove the parallel cables (JP1, JP6, JP7, JP8) connected to the F-6615 (Power Amp Board).
8. Remove the F-6619 ⑧ from the front panel.
9. Remove the eight F-6621 setting screws ⑨.
10. Remove the JP4 (white) and JP5 (red) ⑩ VR connector connected to the F-6623.
11. Remove the front panel ass'y ⑪.

B. How to Remove the F-6615 (Power Amp Board) (See Figs. 7-1, 7-3)

1. Remove the front panel ass'y.
2. Remove the four F-6616 setting screws ⑬.
3. Remove the F-6615 setting screw ⑭ in the rear panel side.
4. Remove the F-6618 setting screw ⑮.
5. Remove the six F-6615 setting screws ⑯.
6. PC support (LSR-12R)
Lift the hook part of the F-6615 up to remove the hook ⑰.
7. Remove the two screws ⑱ setting the rear panel and remove the rear panel from the chassis.
8. Remove F-6615 (Power Amp Board) from the chassis.

Fig. 7-1

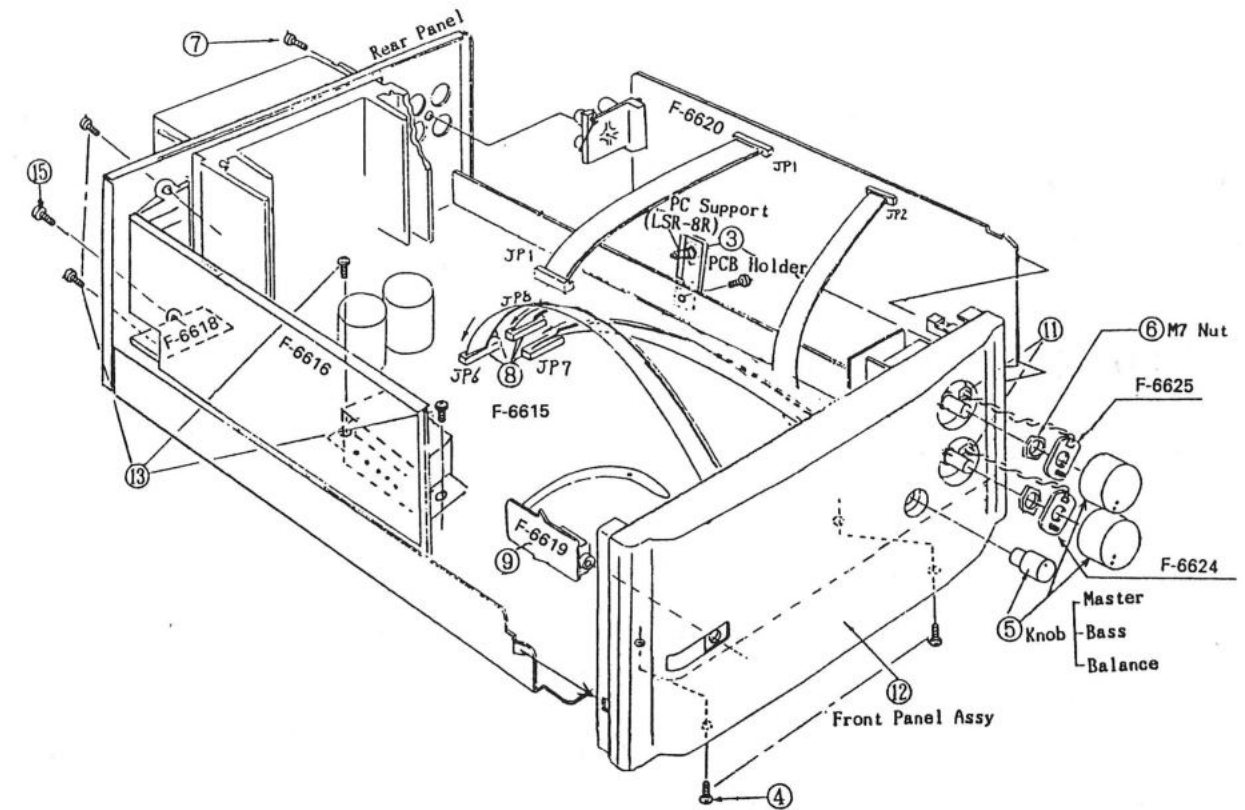

8-2. Main Section

*Design and specifications subject to changes without notice for improvements.

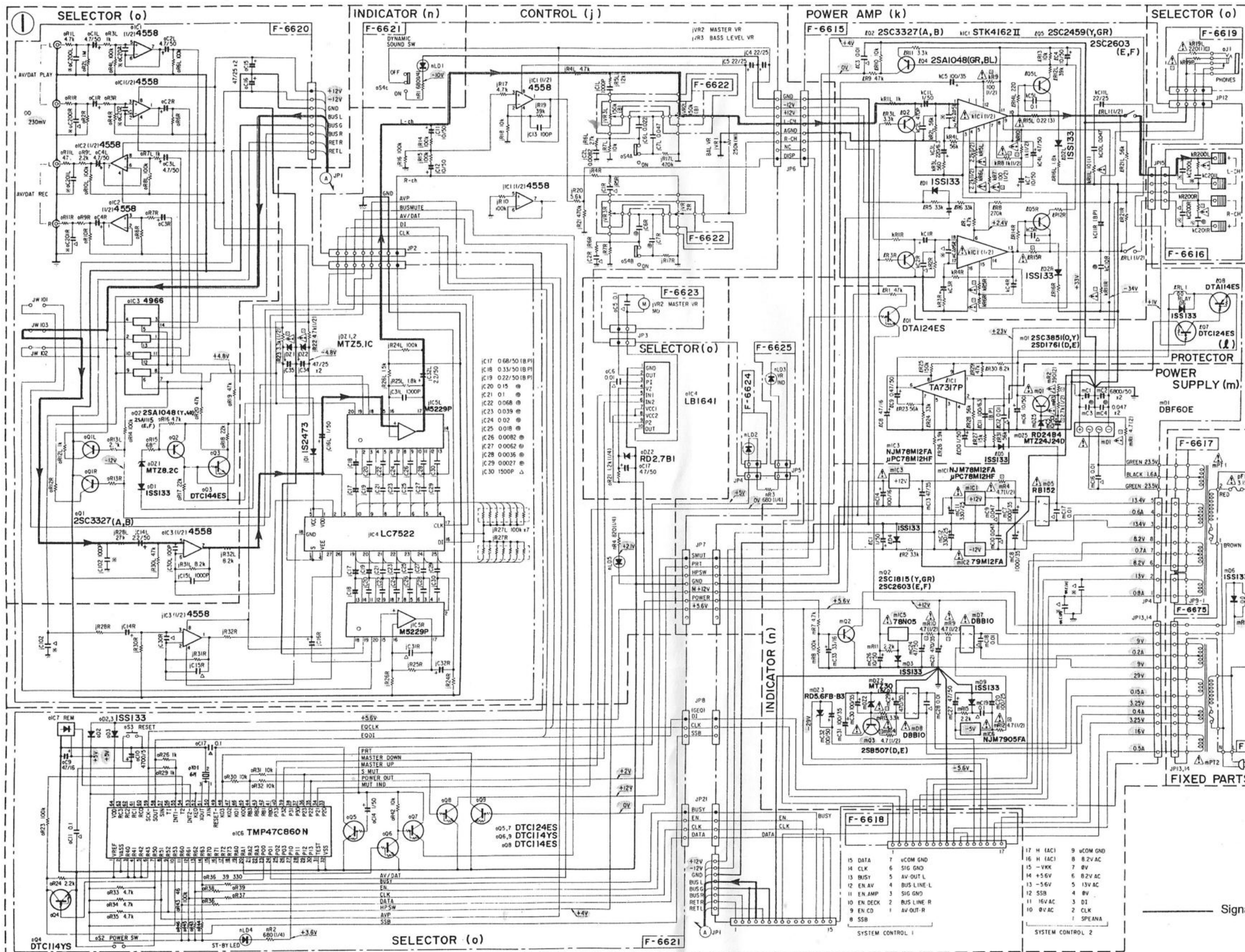

- SYMBOL OF FUNCTION**
- (j) CONTROL
 - (k) POWER AMP
 - (l) PROTECTOR
 - (m) POWER SUPPLY
 - (n) INDICATOR
 - (o) SELECTOR
 - (p) FIXED PARTS

RESISTORS
Are in ohms, 1/6 Watts, ±5% Tolerance Unless Otherwise Noted. K, M, M Ω

CAPACITORS
Are in μF, Unless Otherwise Noted. P, pF
Electrolytic Capacitor
Capacitance μF/Volt (V)

Each DC Voltage shows the nominal value in volts at no input signal.

△ is Safety part.
Use only replacement parts recommended by the manufacturer.

* FTZ Model only

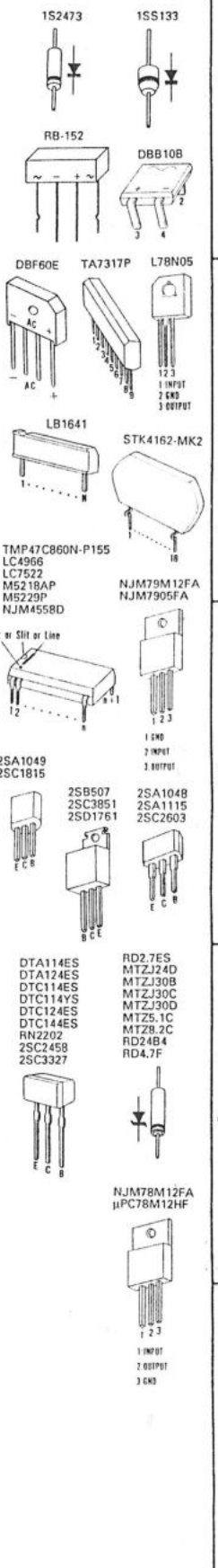

1
2
3

1
2
3
4
5

Fig. 7-2

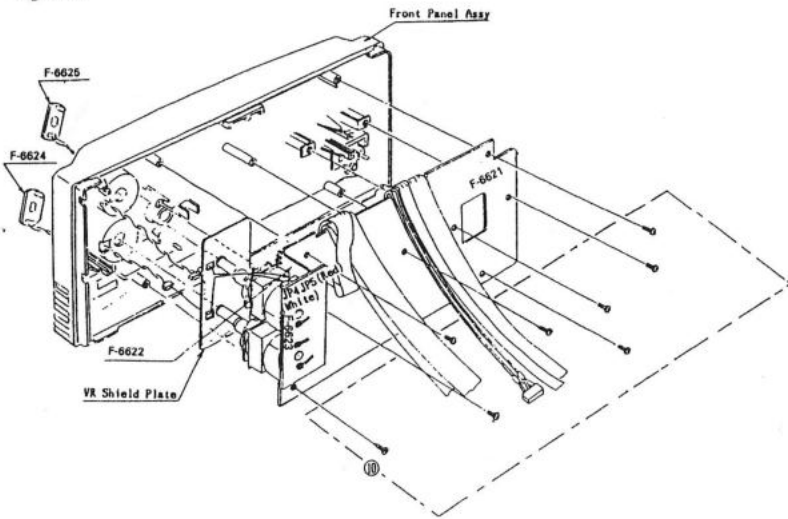
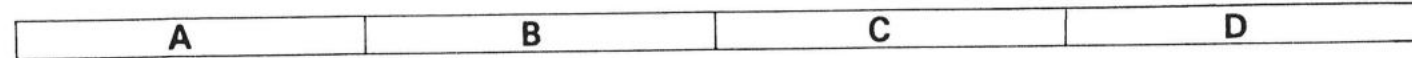
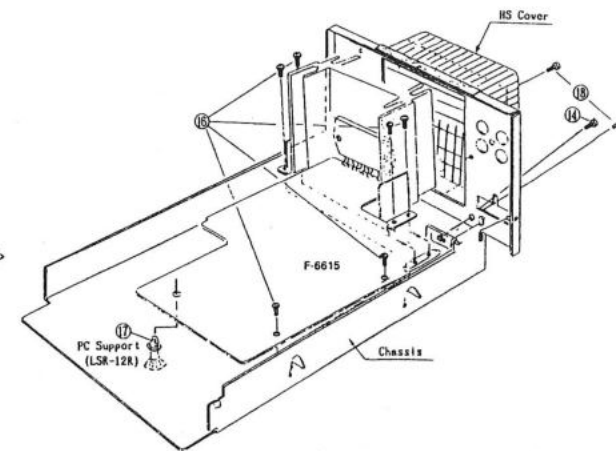
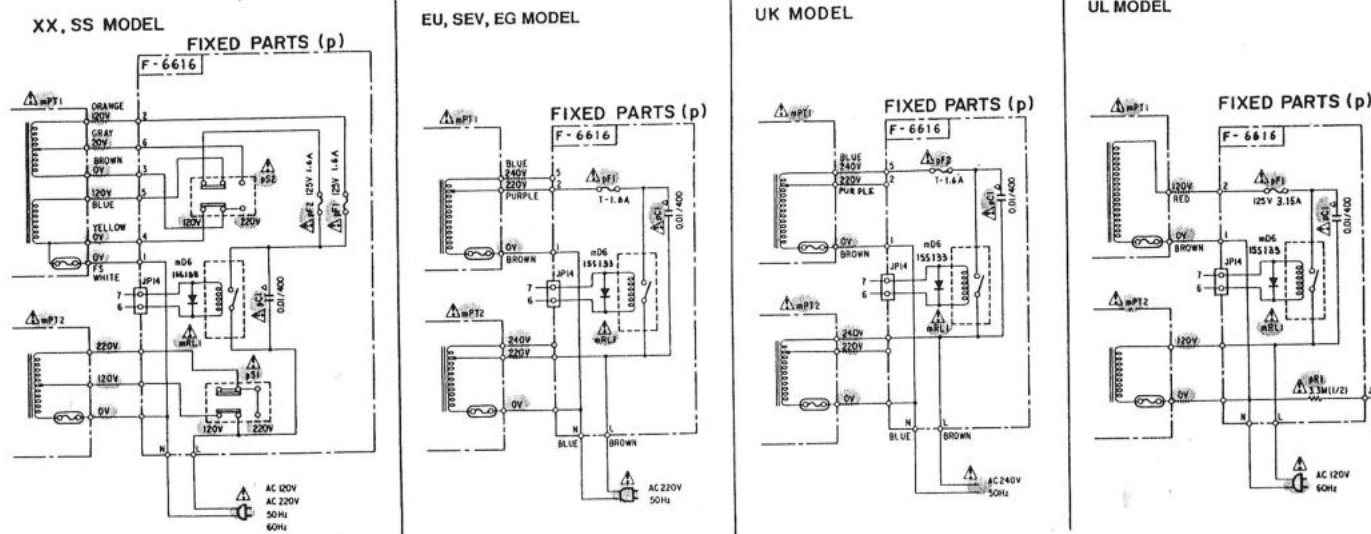

Fig. 7-3



8. SCHEMATIC DIAGRAM

8-1. Power Supply Section



SYMBOL
△ Ceramic Capacitor
CAPACITORS
Are in pF

△ is Safety part.
Use only replacement parts
recommended by the manufac-
turer.

9. INTERIOR BLOCK DIAGRAM & TERMINAL FUNCTION OF ICs

- TMP47C860N-P155 <Amp Controller>
- ◆ Terminal Function

Pin No.	Pin Name	I/O	Function	Active
1	VAREF	—	Reference voltage	
2	VASS	—	Grounding	
7	POWER SW	I	Power SW ON/OFF input terminal	L
8	AVP	I	AV processor control (yes/no) input terminal	L
9	HP-SW	I	Headphone SSB input terminal	L
10	VR SPEED	O	VR speed control input terminal	
11	DATA	O	Display serial data output terminal	
12	CLK	O	Display serial data clock output terminal	
13	ENABLE	I	Display data transfer request signal input terminal	
14	BUSY	O	Display data transfer completed/disabled signal output terminal	
20	BUS MUTE	O	Bus mute output terminal	H
23	SSB OUT	O	SSB (Sansui Serial Bus Data) output terminal	
24	AV/OUT SW	O	AV/DAT analog SW output terminal	L
27	ST-BY LED	O	STANDBY LED output	L
32	GND	—	Grounding	
34	MUTE IND	O	Blinking on Mute by Mute LED, SSB	L
35	POWER OUT	O	ON/OFF output terminal of Power output	H
36	S.MUTE	O	System mute output terminal	H
37	BASS UP	O	Motor VR output, BASS VR UP (oIC5.LB1641 Connected to pin 5)	
38	BASS DOWN	O	Motor VR output, BASS VR DOWN (oIC5.LB1641 Connected to pin 6)	
39	MASTER UP	O	Motor VR output, MASTER VR UP (oIC6.LB1641 Connected to pin 5)	
40	MASTER DOWN	O	Motor VR output, MASTER VR DOWN (oIC6.LB1641 Connected to pin 6)	
48	PRT	I	Protector input terminal	L
50	X' TAL IN	I	6 MHz clock send input terminal	
51	X' TAL OUT	O	6 MHz clock send output terminal	
52	HOLD	I	HOLD mode input terminal. Effected to standby mode or normal mode after RESET.	
53	REM	I	Remote control input terminal	
54	SSB IN	I	SSB (Sansui Serial Bus Data) input terminal	
58	EQ DI	O	Graphic equalizer serial data output terminal	
59	EQ CLK	O	Graphic equalizer serial clock output terminal	
64	VDD		Power source (+5V)	

- LC4966 <Analog Switch>

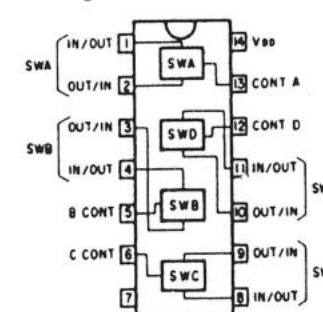

- LC7522 <G-EQ Analog Switch>

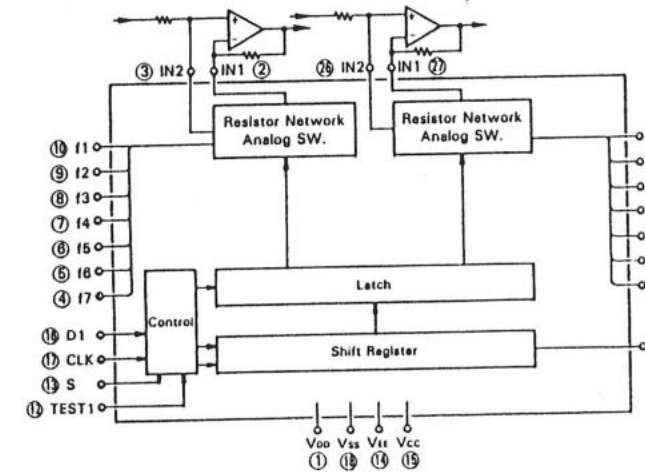

- ◆ Terminal Function <LC7522>

Pin No.	Pin Name	Function
1	Vdd	Terminal for applying a power supply vol a voltage of 7V ± 10% is applied.
15	Vcc	Terminal for applying a device supply vol a voltage of 5V ± 10% is applied.
14	Vee	Terminal for connecting a supply voltage a voltage of -7V ± 10% is applied.
18	Vss	Terminal for ground (0V).
16	DI	Terminal for inputting a data signal from
17	CLK	Terminal for inputting a clock puls from
2, 27	IN 1 (-IN)	Terminal for inputting a audio signal.
3, 26	IN 2 (+IN)	Terminal for inputting a audio signal.
10-4	f1 ~ f7	Terminal for connecting a band pass fil
19-25		
13	S	Terminal for selecting to use two chips

- M5229P <G-EQ Amp>

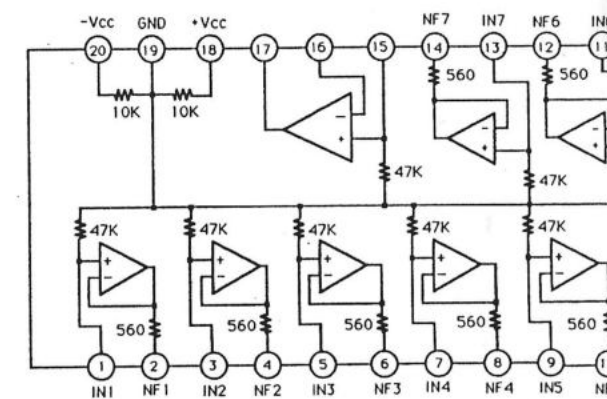

9. INTERIOR BLOCK DIAGRAM & TERMINAL FUNCTION OF ICs

• TMP47C860N-P155 <Amp Controller> ◆ Terminal Function

Pin No.	Pin Name	I/O	Function	Active
1	VAREF	—	Reference voltage	
2	VASS	—	Grounding	
7	POWER SW	I	Power SW ON/OFF input terminal	L
8	AVP	I	AV processor control (yes/no) input terminal	L
9	HP-SW	I	Headphone SSB input terminal	L
10	VR SPEED	O	VR speed control input terminal	
11	DATA	O	Display serial data output terminal	
12	CLK	O	Display serial data clock output terminal	
13	ENABLE	I	Display data transfer request signal input terminal	
14	BUSY	O	Display data transfer completed/disabled signal output terminal	
20	BUS MUTE	O	Bus mute output terminal	H
23	SSB OUT	O	SSB(Sansui Serial Bus Data) output terminal	
24	AV/OUT SW	O	AV/DAT analog SW output terminal	L
27	ST-BY LED	O	STANDBY LED output	L
32	GND	—	Grounding	
34	MUTE IND	O	Blinking on Mute by Mute LED, SSB	L
35	POWER OUT	O	ON/OFF output terminal of Power output	H
36	S.MUTE	O	System mute output terminal	H
37	BASS UP	O	Motor VR output, BASS VR UP (oIC5.LB1641 Connected to pin 5)	
38	BASS DOWN	O	Motor VR output, BASS VR DOWN (oIC5.LB1641 Connected to pin 6)	
39	MASTER UP	O	Motor VR output, MASTER VR UP (oIC6.LB1641 Connected to pin 5)	
40	MASTER DOWN	O	Motor VR output, MASTER VR DOWN (oIC6.LB1641 Connected to pin 6)	
48	PRT	I	Protector input terminal	L
50	X' TAL IN	I	6 MHz clock send input terminal	
51	X' TAL OUT	O	6 MHz clock send output terminal	
52	HOLD	I	HOLD mode input terminal. Effected to standby mode or normal mode after RESET.	
53	REM	I	Remote control input terminal	
54	SSB IN	I	SSB (Sansui Serial Bus Data) input terminal	
58	EQ DI	O	Graphic equalizer serial data output terminal	
59	EQ CLK	O	Graphic equalizer serial clock output terminal	
64	VDD		Power source (+5V)	

• LC4966 <Analog Switch>

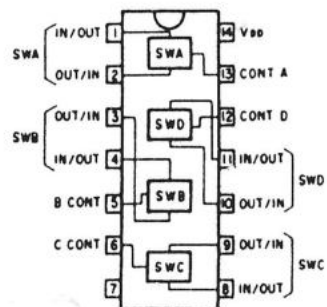

• LC7522 <G-EQ Analog Switch>

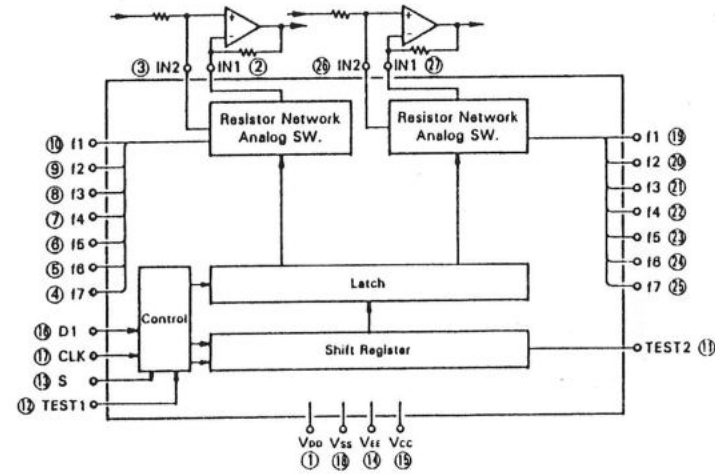

◆ Terminal Function <LC7522>

Pin No.	Pin Name	Function
1	Vdd	Terminal for applying a power supply voltage, a voltage of 7V ± 10% is applied.
15	Vcc	Terminal for applying a device supply voltage, a voltage of 5V ± 10% is applied.
14	Vee	Terminal for connecting a supply voltage (-), a voltage of -7V ± 10% is applied.
18	Vss	Terminal for ground (0V).
16	DI	Terminal for inputting a data signal from CPU.
17	CLK	Terminal for inputting a clock pulse from CPU.
2, 27	IN 1 (-IN)	Terminal for inputting an audio signal.
3, 26	IN 2 (+IN)	Terminal for inputting an audio signal.
10~4	f1 ~ f7	Terminal for connecting a band pass filter.
19~25		
13	S	Terminal for selecting to use two chips.

• M5229P <G-EQ Amp>

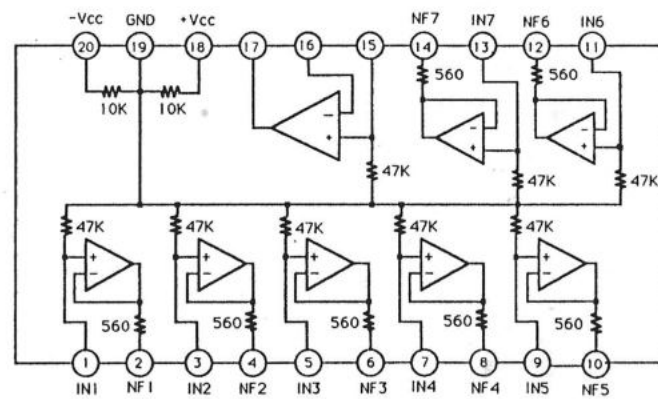

• STK4162-MK2 <Power Amp>

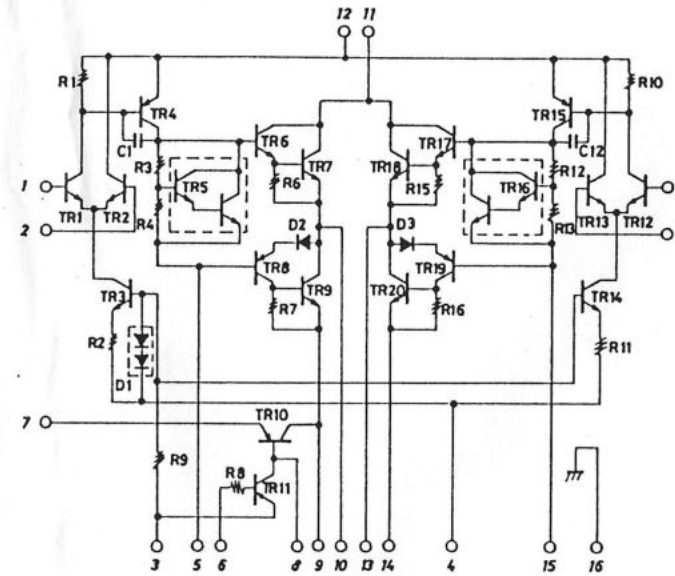

• TA7317P <Protector>

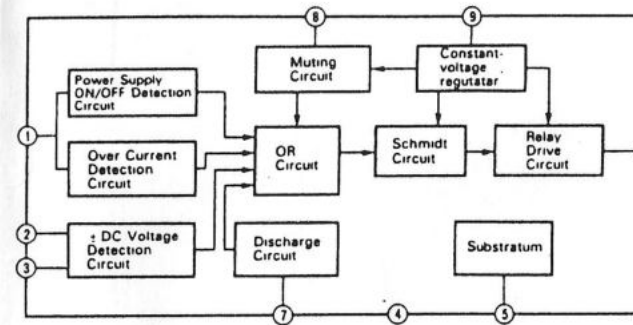

• LB1641 <Motor Drive>

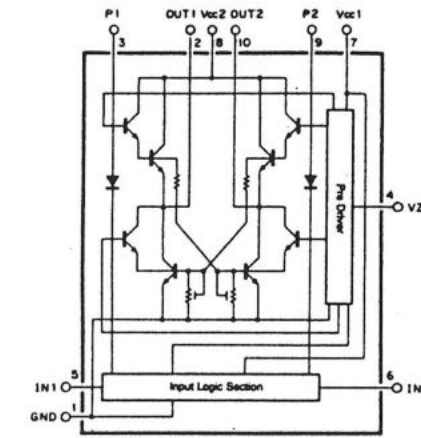

SANSUI ELECTRIC CO., LTD.:

SANSUI USA INC.:

SANSUI DEUTSCHLAND G.M.B.H.:

山水電気株式会社

New River Bldg. 10-14, Shinkawa 1-chome, Chuo-ku, Tokyo 104, Japan

PHONE: (03) 5566-1024 / FAX: 03-5566-1027 (International Division)

1290 Wall Street West, Lyndhurst, New Jersey 07071 U.S.A.

17150 South Margay Ave. Carson, California 90746 U.S.A.

Paul-Ehrlich-Strasse 8, 6074 Rödermark 2, F. R. Germany

東京都中央区新川1-10-14 (〒104)