

# SANSUI SERVICE MANUAL

MODEL  
MICRO 750D

CAUTION : Before servicing this chassis, read the "PRODUCT SAFETY SERVICE FOR VIDEO PRODUCTS" section on page 3 of this manual.



## CONTENTS

## DVD and CD PLAYER

SERVICE PRECAUTIONS .....	2-3
BLOCK DIAGRAMS .....	4-5
IC INTRODUCTION .....	6-21
PRINTED CIRCUIT .....	22-28
REPLACEMENT PARTS LIST .....	29-42

# PRODUCT SAFETY SERVICING GUIDELINES FOR VIDEO PRODUCTS

CAUTION: DO NOT ATTEMPT TO MODIFY THIS PRODUCT IN ANY WAY AND NEVER PERFORM CUSTOMIZED INSTALLATIONS WITHOUT MANUFACTURER'S APPROVAL. UNAUTHORIZED MODIFICATIONS WILL NOT ONLY VOID THE WARRANTY, BUT MAY LEAD TO YOUR BEING LIABLE FOR ANY RESULTING PROPERTY DAMAGE OR USER INJURY.

SERVICE WORK SHOULD BE PERFORMED ONLY AFTER YOU ARE THOROUGHLY FAMILIAR WITH ALL OF THE FOLLOWING SAFETY CHECKS AND SERVICING GUIDELINES. TO DO OTHERWISE, INCREASES THE RISK OF POTENTIAL HAZARDS AND INJURY TO THE USER.

WHILE SERVICING, USE AN ISOLATION TRANSFORMER FOR PROTECTION FROM A.C. LINE SHOCK.

## SAFETY CHECKS

AFTER THE ORIGINAL SERVICE PROBLEM HAS BEEN CORRECTED, A CHECK SHOULD BE MADE OF THE FOLLOWING.

### SUBJECT: FIRE & SHOCK HAZARD

1. BE SURE THAT ALL COMPONENTS ARE POSITIONED IN SUCH A WAY AS TO AVOID POSSIBILITY OF ADJACENT COMPONENT SHORTS. THIS IS ESPECIALLY IMPORTANT ON THOSE MODULES WHICH ARE TRANSPORTED TO AND FROM THE REPAIR SHOP.
2. NEVER RELEASE A REPAIR UNLESS ALL PROTECTIVE DEVICES SUCH AS INSULATORS, BARRIERS, COVERS, SHIELDS, STRAIN RELIEFS, POWER SUPPLY CORDS, AND OTHER HARDWARE HAVE BEEN REINSTALLED PER ORIGINAL DESIGN. BE SURE THAT THE SAFETY PURPOSE OF THE POLARIZED LINE PLUG HAS NOT BEEN DEFEATED.
3. SOLDERING MUST BE INSPECTED TO DISCOVER POSSIBLE COLD SOLDER JOINTS, SOLDER SPLASHES OR SHARP SOLDER POINTS. BE CERTAIN TO REMOVE ALL LOOSE FOREIGN PARTICLES.
4. CHECK FOR PHYSICAL EVIDENCE OF DAMAGE OR DETERIORATION TO PARTS AND COMPONENTS, FOR FRAYED LEADS AND DAMAGED INSULATION (INCLUDING A.C. CORD), AND REPLACE IF NECESSARY FOLLOW ORIGINAL LAYOUT, LEAD LENGTH AND DRESS.
5. NO LEAD OR COMPONENT SHOULD TOUCH A RECEIVING TUBE OR A RESISTOR RATED AT 1 WATT OR MORE. LEAD TENSION AROUND PROTRUDING METAL SURFACES MUST BE AVOIDED.
6. ALL CRITICAL COMPONENTS SUCH AS FUSES, FLAMEPROOF RESISTORS, CAPACITORS, ETC. MUST BE REPLACED WITH EXACT FACTORY TYPES, DO NOT USE REPLACEMENT COMPONENTS OTHER THAN THOSE SPECIFIED OR MAKE UNRECOMMENDED CIRCUIT MODIFICATIONS.
7. AFTER RE-ASSEMBLY OF THE SET, ALWAYS PERFORM AN A.C. LEAKAGE TEST ON ALL EXPOSED METALLIC PARTS OF THE CABINET, (THE CHANNEL SELECTOR KNOB, ANTENNA TERMINALS, HANDLE AND SCREWS) TO BE SURE THE SET IS SAFE TO OPERATE WITHOUT DANGER OF ELECTRICAL SHOCK. DO NOT USE A LINE ISOLATION TRANSFORMER DURING THIS TEST, MAKE SURE TO USE AN A.C. VOLTMETER. HAVING 5000 OHMS PER VOLT OR MORE SENSITIVITY, IN THE FOLLOWING MANNER; CONNECT A 1500 OHMS 10 WATT RESISTOR, PARALLELED BY A .15 MFD. 150V A.C. TYPE CAPACITOR BETWEEN A KNOWN GOOD EARTH GROUND (WATER PIPE, CONDUIT, ETC.) AND THE EXPOSED METALLIC PARTS, ONE AT A TIME. MEASURE THE A.C. VOLTAGE ACROSS THE COMBINATION OF 1500 OHM RESISTOR AND 15 MFD CAPACITOR. REVERSE THE A.C. PLUG AND REPEAT A.C. ANY VOLTAGE MEASUREMENTS FOR EACH EXPOSED METALLIC PART. VOLTAGE MEASURED MUST NOT EXCEED 75 VOLTS R.M.S. THIS CORRESPONDS TO 0.5 MILLIAMPS A.C. ANY VALUE EXCEEDING THIS LIMIT CONSTITUTES A POTENTIAL SHOCK HAZARD AND MUST BE CORRECTED IMMEDIATELY.

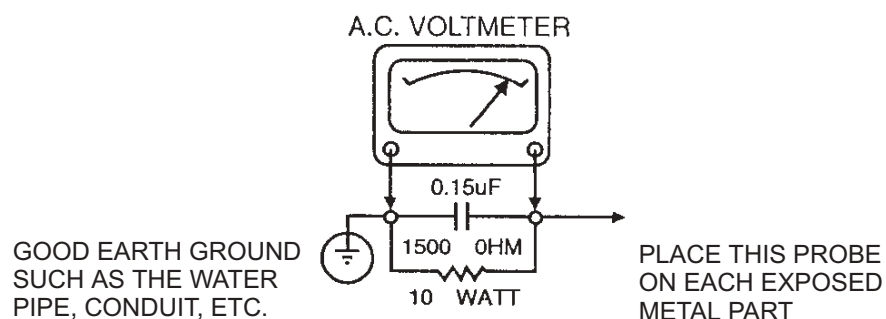

### SUBJECT GRAPHIC SYMBOLS



THE LIGHTNING FLASH WITH APOWHEAD SYMBOL. WITHIN AN EQUILATERAL TRIANGLE, IS INTENDED TO ALERT THE SERVICE PERSONNEL TO THE PRESENCE OF UNINSULATED "DANGEROUS VOLTAGE" THAT MAY BE OF SUFFICIENT MAGNITUDE TO CONSTITUTE A RISK OF ELECTRIC SHOCK.



THE EXCLAMATION POINT WITHIN AN EQUILATERAL TRIANGLE IS INTENDED TO ALERT THE SERVICE PERSONNEL TO THE PRESENCE OF IMPORTANT SAFETY INFORMATION IN SERVICE LITERATURE.

### SUBJECT: X-RADIATION

1. BE SURE PROCEDURES AND INSTRUCTIONS TO ALL SERVICE PERSONNEL COVER THE SUBJECT OF X-RADIATION. THE ONLY POTENTIAL SOURCE OF X-RAYS IN CURRENT T.V. RECEIVERS IS THE PICTURE TUBE. HOWEVER, THIS TUBE DOES NOT EMIT X-RAYS WHEN THE HIGH VOLTAGE IS AT THE FACTORY SPECIFIED LEVEL. THE PROPER VALUE IS GIVEN IN THE APPLICABLE SCHEMATIC. OPERATION AT HIGHER VOLTAGES MAY CAUSE A FAILURE OF THE PICTURE TUBE OR HIGH VOLTAGE SUPPLY AND, UNDER CERTAIN CIRCUMSTANCES, MAY PRODUCE RADIATION IN EXCESS OF DESIRABLE LEVELS.
2. ONLY FACTORY SPECIFIED C.R.T ANODE CONNECTORS MUST BE USED. DEGAUSSING SHIELDS ALSO SERVE AS AN X-RAY SHIELD IN COLOR SETS, ALWAYS RE-INSTALL THEM.
3. IT IS ESSENTIAL THAT SERVICE PERSONNEL HAVE AVAILABLE AN ACCURATE AND RELIABLE HIGH VOLTAGE METER. THE CALIBRATION OF THE METER SHOULD BE CHECKED PERIODICALLY AGAINST A REFERENCE STANDARD, SUCH AS THE ONE AVAILABLE AT YOUR DISTRIBUTOR.
4. WHEN THE HIGH VOLTAGE CIRCUITRY IS OPERATING PROPERLY, THERE IS NO POSSIBILITY OF AN X-RADIATION PROBLEM. EVERY TIME A COLOR CHASSIS IS SERVICED, THE BRIGHTNESS SHOULD BE RUN UP AND DOWN WHILE MONITORING THE HIGH VOLTAGE WITH A METER TO BE CERTAIN THAT THE HIGH VOLTAGE DOES NOT EXCEED THE SPECIFIED VALUE AND THAT IT IS REGULATING CORRECTLY. WE SUGGEST THAT YOU AND YOUR SERVICE ORGANIZATION REVIEW TEST PROCEDURES SO THAT VOLTAGE REGULATION IS ALWAYS CHECKED AS A STANDARD SERVICING PROCEDURE AND THAT THE HIGH VOLTAGE READING BE RECORDED ON EACH CUSTOMER'S INVOICE.
5. WHEN TROUBLESHOOTING AND MAKING TEST MEASUREMENTS IN A PRODUCT WITH A PROBLEM OF EXCESSIVE HIGH VOLTAGE AVOID BEING UNNECESSARILY CLOSE TO THE PICTURE TUBE AND THE HIGH VOLTAGE SUPPLY DO NOT OPERATE THE PRODUCT LONGER THAN IT IS NECESSARY TO LOCATE THE CAUSE OF EXCESSIVE VOLTAGE.
6. REFER TO HV. B+ AND SHUTDOWN ADJUSTMENT PROCEDURES DESCRIBED IN THE APPROPRIATE SCHEMATIC AND DIAGRAMS (WHERE USED).

### SUBJECT: IMPLOSION

1. ALL DIRECT VIEWED PICTURE TUBES ARE EQUIPPED WITH AN INTEGRAL IMPLOSION PROTECTION SYSTEM, BUT CARE SHOULD BE TAKEN TO AVOID DAMAGE DURING INSTALLATION, AVOID SCRATCHING THE TUBE. IF SCRATCHED REPLACE IT.
2. USE ONLY RECOMMENDED FACTORY REPLACEMENT TUBES.

### SUBJECT: TIPS ON PROPER INSTALLATION

1. NEVER INSTALL ANY PRODUCT IN A CLOSED-IN RECESS. CUBBYHOLE OR CLOSELY FITTING SHELF SPACE, OVER OR CLOSE TO HEAT DUCT, OR IN THE PATH OF HEATED AIR FLOW.
2. AVOID CONDITIONS OF HIGH HUMIDITY SUCH AS: OUTDOOR PATIO INSTALLATIONS WHERE DEW IS A FACTOR, NEAR STEAM RADIATORS WHERE STEAM LEAKAGE IS A FACTOR, ETC.
3. AVOID PLACEMENT WHERE DRAPERIES MAY OBSTRUCT REAR VENTING. THE CUSTOMER SHOULD ALSO AVOID THE USE OF DECORATIVE SCARVES OR OTHER COVERINGS WHICH MIGHT OBSTRUCT VENTILATION.
4. WALL AND SHELF MOUNTED INSTALLATIONS USING A COMMERCIAL MOUNTING KIT, MUST FOLLOW THE FACTORY APPROVED MOUNTING INSTRUCTIONS. A PRODUCT MOUNTED TO A SHELF OR PLATFORM MUST RETAIN ITS ORIGINAL FEET (OR THE EQUIVALENT THICKNESS IN SPACERS) TO PROVIDE ADEQUATE AIR FLOW ACROSS THE BOTTOM. BOLTS OR SCREWS USED FOR FASTENERS MUST NOT TOUCH ANY PARTS OR WIRING. PERFORM LEAKAGE TEST ON CUSTOMIZED INSTALLATIONS.
5. CAUTION CUSTOMERS AGAINST THE MOUNTING OF A PRODUCT ON SLOPING SHELF OR A TILTED POSITION, UNLESS THE PRODUCT IS PROPERLY SECURED.
6. A PRODUCT ON A ROLL-ABOUT CART SHOULD BE STABLE ON ITS MOUNTING TO THE CART CAUTION THE CUSTOMER ON THE HAZARDS OF TRYING TO ROLL A CART WITH SMALL CASTERS ACROSS THRESHOLDS OR DEEP PILE CARPETS.
7. CAUTION CUSTOMERS AGAINST THE USE OF A CART OR STAND WHICH HAS NOT BEEN LISTED BY UNDERWRITERS LABORATORIES, INC. FOR USE WITH THEIR SPECIFIC MODEL OF TELEVISION RECEIVER OR GENERICALLY APPROVED FOR USE WITH TV'S OF THE SAME OR LARGER SCREEN SIZE.
8. CAUTION CUSTOMERS AGAINST THE USE OF EXTENSION CORDS. EXPLAIN THAT A FOREST OF EXTENSIONS SPROUTING FROM A SINGLE OUTLET CAN LEAD TO DISASTROUS CONSEQUENCES TO HOME AND FAMILY.

# SERVICING PRECAUTIONS

**CAUTION :** Before servicing the DVD covered by this service data and its supplements and ADDENDUMS, read and follow the *SAFETY PRECAUTIONS NOTE* : if unforeseen circumstances create conflict between the following servicing precautions and any of the safety precautions in this publications, always follow the safety precautions.

*Remember Safety First:*

## General Servicing Precautions

1. Always unplug the DVD AC power cord from the AC power source before:
  - (1) Removing or reinstalling any component, circuit board, module, or any other assembly.
  - (2) Disconnection or reconnecting any internal electrical plug or other electrical connection.
  - (3) Connecting a test substitute in parallel with an electrolytic capacitor

**Caution :** A wrong part substitution or incorrect polarity installation of electrolytic capacitors may result in an explosion hazard.
2. Do not spray chemicals on or near this DVD or any of its assemblies.
3. Unless specified otherwise in this service data, clean electrical contacts by applying an appropriate contact cleaning solution to the contacts with a pipe cleaner, cotton-tipped swab, or comparable soft applicator.  
Unless specified otherwise in this service data, lubrication of contacts is not required.
4. Do not defeat any plug/socket B+ voltage interlocks with wotch instruments covered by this service manual might be equipped.
5. Do not apply AC power to this DVD and/or any of its electrical assemblies unless all solid-state device heat sinks are correctly installed.
6. Always connect test instrument ground lead to the appropriate ground before connection the test instrument positive lead. Always remove the test instrument ground lead last.

## Insulation Checking Procedure

Disconnect the attachment plug from the AC outlet and turn the power on. Connect an insulation resistance meter(500V) to the blades of the attachment plug. The insulation resistance between each blade of the attachment plug and accessible conductive parts (Note 1) should be more than 1M ohm.

**Note 1 :** Accessible Conductive Parts including Metal panels, input terminals, Earphone jacks, etc.

## Electrostatically Sensitive (ES) Devices

Some semiconductor (solid state) devices can be damaged easily by static electricity. Such components commonly are called Electrostatically Sensitive (ES) Devices. Examples of typical ES devices are integrated circuits and some field effect transistors and semiconductor chip components.

The following techniques should be used to help reduce the incidence of component damage caused by static electricity.

1. Immediately before handling any semiconductor component or semiconductor-equipped assembly, drain off any electrostatic charge on your body by touching a known earth ground. Alternatively, obtain and wear a commercially available discharging wrist strap device, which should be removed for potential shock reasons prior to applying power to the unit under test.
2. After removing an electrical assembly equipped with ES devices, place the assembly on a conductive surface such as aluminum foil, to prevent electrostatic charge buildup or exposure of the assembly.
3. Use only a GROUNDED-tip soldering iron to solder or unsolder ES devices.
4. Use only an anti-static solder removal device. Some solder removal devices not classified a "anti-static" can generate electrical charges sufficient to damage ES devices.
5. Do not use freon-propelled chemicals. These can generate electrical charge sufficient to damage ES devices.
6. Do not remove a replacement ES device from its protective package until immediately before you are ready to install it. (Most replacement ES devices are packaged with leads electrically shorted together by conductive foam, aluminum foil, or comparable conductive material.)
7. Immediately before removing the protective material from the leads of a replacement ES device, touch the protective material to the chassis or circuit assembly into which the device will be installed.

**Caution :** Be sure no power is applied to the chassis or circuit, and observe all other safety precautions.

8. Minimize bodily motions when handling unpackaged replacement ES devices. (Normally harmless motion such as the brushing together of your clothes fabric or the lifting of your foot from a carpeted floor can generate static electricity sufficient to damage an ES device.)

# OVERALL BLACK DIAGRAM

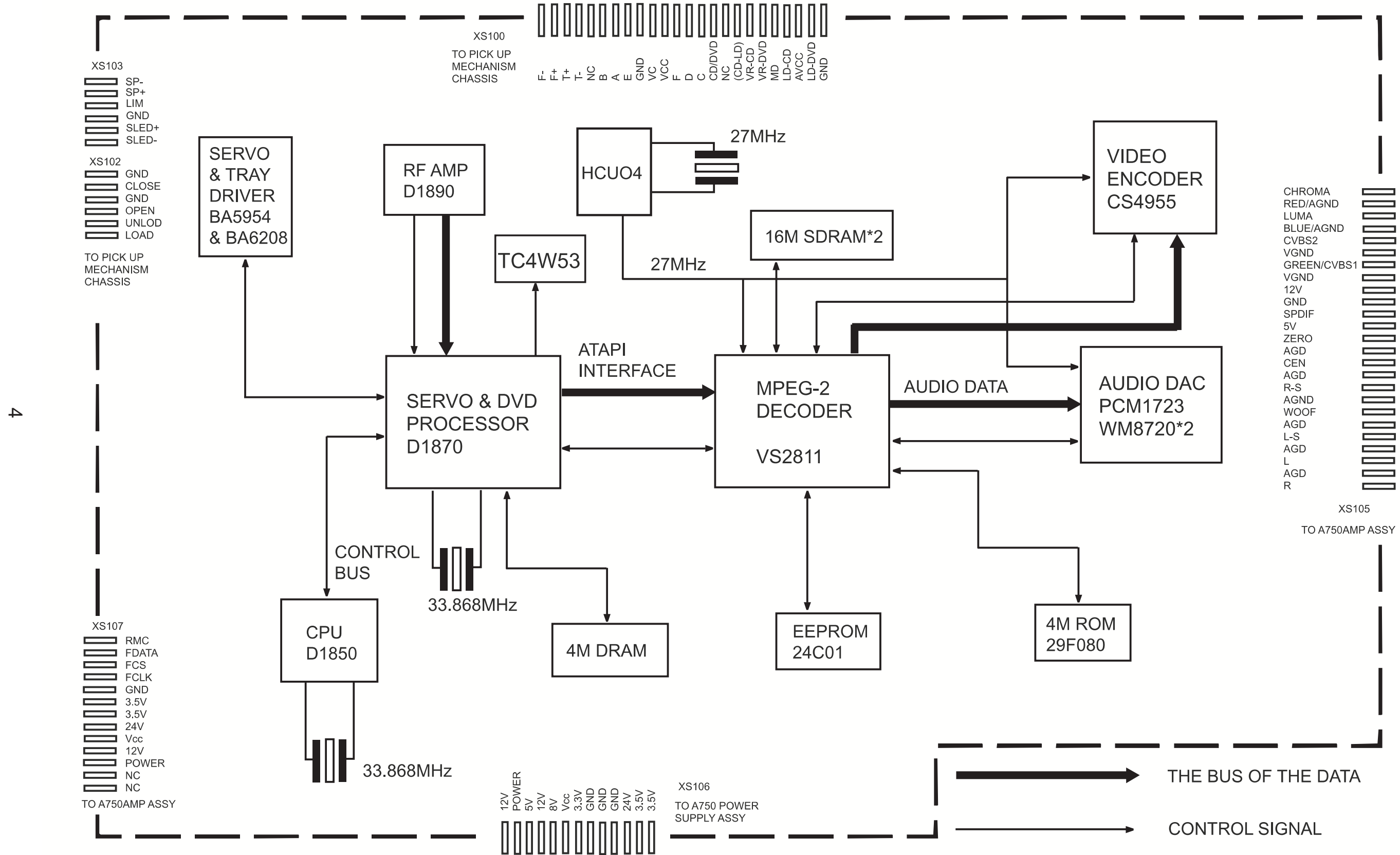

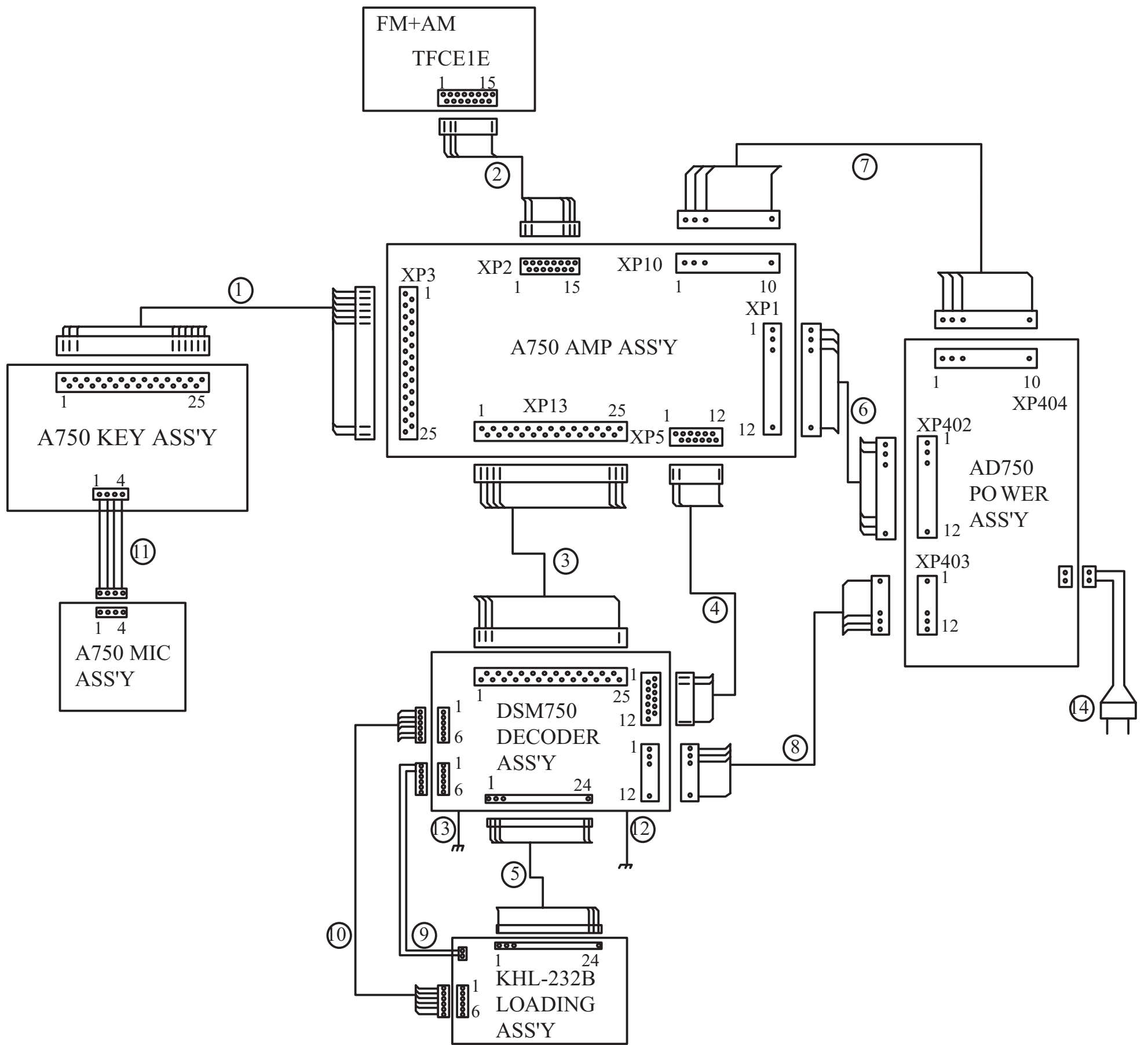

## IC INTRODUCTION

### D1890 PIN ASSIGNMENTS

Pin Numbers	PIN NAME	Type	Description
QFP100 and LQFP100			
RF Flag Interface			
13	DEFECT	Digital Output	Flag of bad data output status
RF SIO interface			
14	SLCK	Digital Input	RF serial clock input
15	SDEN	Digital Input	RF serial data enable
16	SDATA	Digital IO	RF serial data IO
11	RST	Digital input	Reset (active high)
12	XCK16M	Digital input	16.9MHz for verification
RF			
40	DVDA	Analog input	DVD RF signal input A
41	DVDB	Analog Input	DVD RF signal input B
42	DVDC	Analog Input	DVD RF signal input C
43	DVDD	Analog Input	DVD RF signal input D
38	DVDRFIN	Analog Input	DVD RF signal input RFIN
39	DVDRFIP	Analog Input	DVD RF signal input RFIP
53	CDA	Analog Input	CD RF signal input A
54	CDB	Analog Input	CD RF signal input B
55	CDC	Analog Input	CD RF signal input C
56	CDD	Analog Input	CD RF signal input D
61	OSP	Analog	Offset cancellation capacitor connecting
60	OSN	Analog	Offset cancellation capacitor connecting
86	RFOP	Analog output	RF positive output
85	RFON	Analog output	RF negative output
59	RFGC	Analog	RF VGA control
TRACKING ERROR			
88	DPFN	Analog	DPD amplifier negative input
87	DPFO	Analog	DPD amplifier output
23	IR	Analog	DPD reference resister connecting
17	DPDMUTE	Digital input	DPD mute control input
83	TNI	Analog Input	3 beam satellite PD signal input
82	TPI	Analog Input	3 beam satellite PD signal input
97	TEO	Analog Output	Tracking error output
FOCUSING ERROR & RF LEVEL & CENTRAL SERVO SIGNAL			
64	CDFNI	Analog Input	CD focusing error negative input
65	CDFPI	Analog Input	CD focusing error positive input
44	DVDFNI	Analog input	DVD focusing error negative input
45	DVDFPI	Analog input	DVD focusing error positive input
95	FEO	Analog Output	Focusing error output
96	FEONI	Analog Input	Focusing error amplifier negative input
93	FLVL	Analog Output	RF level output

Pin Numbers	PIN NAME	Type	Description
94	FLVLNI	Analog input	RF level amplifier negative input
69	CDCSNI	Analog input	CD central servo signal negative input
70	CDCSPI	Analog input	CD central servo signal positive input
46	DVDCSNI	Analog input	DVD central servo signal negative input
47	DVDCSPI	Analog input	DVD central servo signal positive input
2	CSO	Analog output	Central servo signal output
3	CSONI	Analog input	Central servo amplifier negative input
ALPC			
80	MDI1	Analog Input	Laser power monitor input
81	LDO1	Analog Output	Laser driver output
51	MDI2	Analog Input	Laser power monitor input
52	LDO2	Analog Output	Laser driver output
RF RIPPLE			
8	CRTP	Analog	RF top envelop filter capacitor connecting
9	CRTPLP	Analog	Defect level filter capacitor connecting
7	HRFRP	Analog output	High frequency RF ripple output
6	LRFRP	Analog output	Low frequency RF ripple output
POWER			
24,25,30,34,62,63	AVDD	Power	RF power
21,22,28,37,57,58	AGND	GND	GND
89,90	SVDD	Power	Servo analog power
98,99	SGND	GND	GND
4,5	VDD	Power	Digital power
18,19	GND	GND	GND
REFERENCE VOLTAGE			
92	VREFO	Analog output	Reference voltage 2.0V
91	V2REFO	Analog output	Reference voltage 4.0V
ALPC TRIMMING			
32	TM1	Analog input	Trimming pin for ALPC1
33	TM2	Analog input	Trimming pin for ALPC1
35	TM3	Analog input	Trimming pin for ALPC2
36	TM4	Analog input	Trimming pin for ALPC2
HIGH SPEED TRACK COUNTING			
1	TRLP	Analog	Low-pass filter capacitor connecting
100	TRLPA	Analog	Low-pass filter capacitor connecting
10	HTRC	Digital output	High speed track counting digital output
FOR MONITOR ONLY			
26	MON	Analog output	
27	MOP	Analog output	
31	VCON	Analog output	
20	HTRCMPH	Digital output	
84	HTE	Analog output	

# D1890 BLOCK DIAGRAM

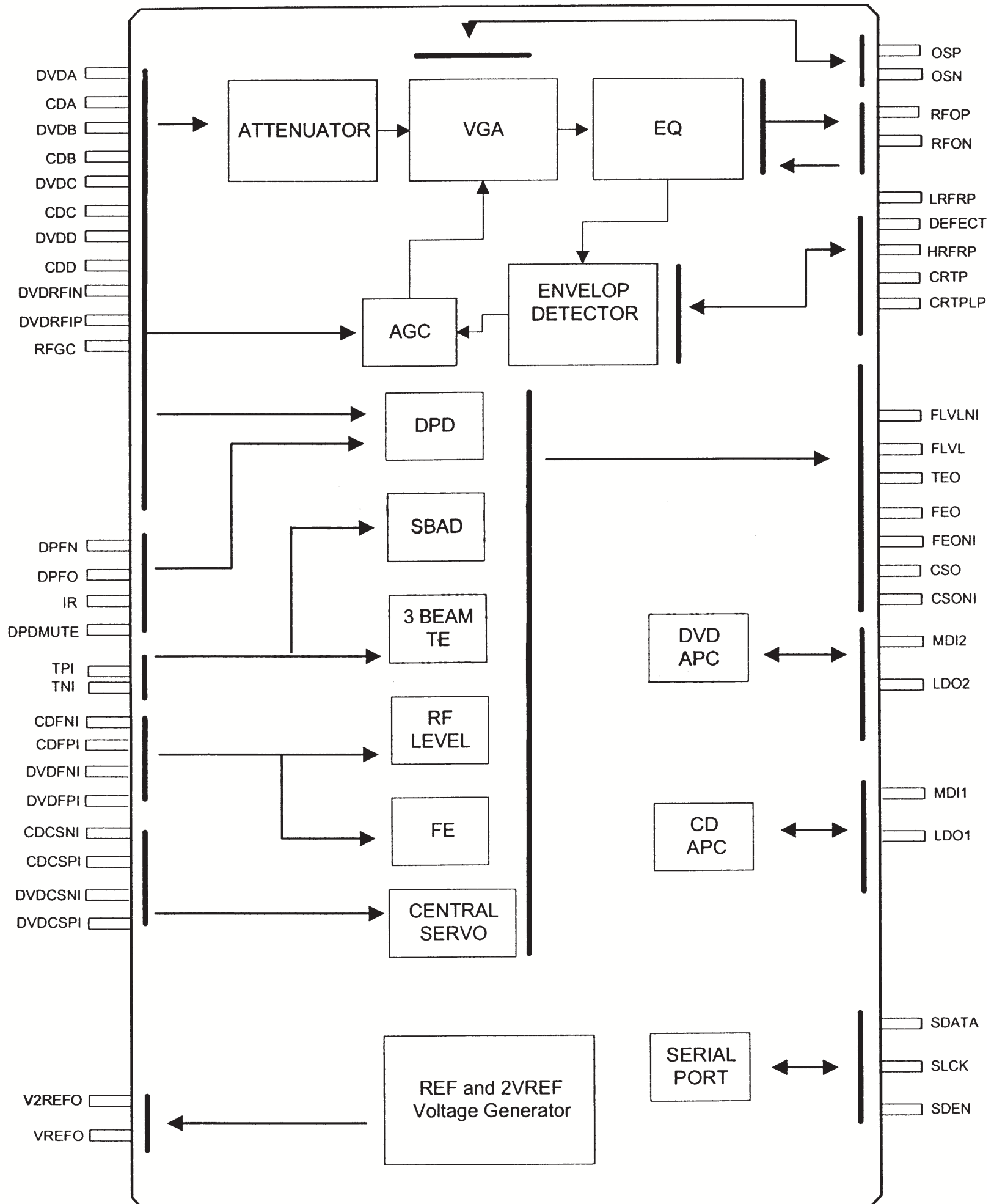



## D1870 PIN ASSIGNMENTS

Pin Numbers	Pin NAME	Type	Description
RG data PLL interface			
11	PLLVD	Power	Power for data PLL and related analog circuitry.
10	JITFN	Analog Input	The negative input terminal of operation amplifier for RF jitter meter.
9	JITFO	Analog Output	The output terminal of RF jitter meter.
8	PDO	Analog Output	Phase comparator output. Output the phase difference of EFM and Pck4m. Sink or source a constant current to loop filter over this pin when phase difference occurs. Otherwise, this pin is high impedance.
7	IREF	Analog Input	Current reference input. It generates reference current for data PLL. Connect an external 15K resistor to this pin and PLLVSS.
6	LPFN	Analog Input	The negative input terminal of loop filter amplifier.
5	LPFO	Analog Output	The output of loop filter amplifier.
4	LPIN	Analog Input	The input of the low pass filter.
3	LPIO	Analog Output	The output of the low pass filter.
2	PLLVSS	Ground	Ground pin for data PLL and related analog circuitry.
1	VBDPLL	Analog Output	Reference voltage.
176	RFIN	Analog Input	The negative input terminal of RF differential signal.
175	RFIP	Analog Input	The positive input terminal of RF differential signal.
174	RFDSL	Analog Output	RF data slicer level output.
173	SCO	Analog Output	Analog slicer current output.
Signal Amplifier Interface			
172	ADCVDD	Power	Power pin for ADC circuitry.
171	HRFZC	Analog Input	High frequency RF ripple zero crossing input or photo interrupt pulse input.
170	RFRPSLV	Analog Output	RF ripple slice level output.
169	RFP	Analog Input	RF ripple detect input.
168	RFLEVEL	Analog Input	Sub beam add input or RF level input.
167	FEI	Analog Input	Focus error input.
166	TEI	Analog Input	Tracking error input.
165	TEZU	Analog Input	Tracking error zero crossing input.
164	TEZISLV	Analog Input	Tracking error zero crossing low pass input.
163	ADIN	Analog Input	General A/D input.
162	ADCVSS	Ground	Ground pin for ADC circuitry.
Motor and Actuator Drive Interface			
161	PDMVSS	Ground	Ground for PDM Circuitry.
160	PWM2VREF	Analog Input	A reference voltage input for PWM circuitry. The typical value is 4.0V.
159	PWMVREF	Analog Input	A reference voltage input for PWM circuitry. The typical value is 2.0V.
158	PDMVDD	Power	Power for PDM circuitry.
12	FOO	Analog Output	Focus servo output. PDM output of focus servo compensator.
13	TRO	Analog Output	Tracking servo output. PDM output of tracking servo compensator.
14	PWMOUT1	Analog Output	1 st General multi-level PWM output. The number of output levels is set with DSP command. It is used to control step motor.
15	PWMOUT2	Analog Output	2 nd General multi-level PWM output. The number of output level is selected DSP command.
17	DMO	Analog Output	Disk motor control output. PWM output.
18	FMO	Analog Output	Disk motor control. 3-level PWM output. It is used only for DC motor, but it is corporate with the pin PWMOUT1 to control step motor. If the internal DC_FMO is positive, the FMO output lags 90° than PWMOUT1, otherwise the FMO output leads 90° than PWMOUT1.
19	FROPENPW M	Analog Output	Tray open control output. It generates PWM output for TRWMEN <sub>27hRW2</sub> =0 or digital output for TRWMEN <sub>27hRW2</sub> =0.
20	FG	TTL Schmitt Input 50K pull up	Motor Hall sensor input.
22	TRCLOSE	TTL Output	Tray close output. It provides a clock out to the micro controller.
23	ENDM	TTL Output	Enable/disable disk motor. A logical high enables disk motor.
Panel Interface			

Pin Numbers	Pin NAME	Type	Description
24	LED	TTL Output	LED control output.
25	PLY#/PAU#	TTL Input 50K pull up	Play/pause key input, active low.
26	EJ/STOP#	TTL Input 50K pull up	Eject, stop key input, active low.
27	LIMIT#	TTL Input 50K pull up	Sledge inner limit input, active low.
28	TRAYOUT#	TTL Input 50K pull up	Tray_is_out input. A logical low indicates the tray is out. Feedback flag from tray connector.
29	TRAYIN#	TTL Input 50K pull up	Tray_is_in input. A logical low indicates the tray is in. Feedback flag from tray connector.
Micro controller Interface			
30	URST	TTL Output	Power-on reset output for external devices, active high. If the flash mode is used, the micro controller must be the kind of multiplexed address/data mode and its output pins must be at tri-state. Otherwise, the flash mode cannot be used.
31	UWR#	TTL Schmitt Input 50K pull up	Micro controller write strobe, active low.
32	URD#	TTL Schmitt Input 50K pull up	Micro controller read strobe, active low.
33	UCS1	TTL I/O 50K pull up	For non flash mode cycle: register bank select control 1, input from micro controller. For flash mode cycle: flash ROM address FLASH_ADR14.
34	UCS2	TTL I/O 50K pull up	For non flash mode cycle: register bank select control 2, input from micro controller. For flash mode cycle: flash ROM address FLASH_ADR15.
36	UALE	TTL I/O with Schmitt Input 50K pull up	For non flash mode cycle: address latch enable, high active input from micro controller. For flash mode cycle: address latch enable, high active output to control external 373.
37-43,46	UAD	TTL I/O 50K pull up	For non flash mode cycle: micro control address/data Bus. For flash mode cycle: flash ROM address/data bus. FLASH_ADR[7:0]/FLASH_D[7:0]. The FLASH_ADR[7:0] is latched in the external 373.
47	UINT#	TTL Output Open drain	Micro controller Interrupt, low active.
Crystal Interface & DRAM clock Interface			
44	DMVSS	Ground	Ground pin for DRAM clock circuitry.
45	DMVDD	Power	Power pin for DRAM clock circuitry.
48	XTALI	Input	Crystal input. The working frequency in 33.8688MHz.
49	XTALO	Output	Crystal output.
Memory Interface			
50	DQM	TTL Output	For non flash mode: SDRAM output Mask. For flash mode: flash ROM address FLASH_ADR13.
51	BA1	TTL Output	For non flash mode: SDRAM bank address 1 For flash mode: flash ROM address FLASH_ADR12.
52	BA0	TTL Output	For non flash mode: SDRAM bank address 0 For flash mode: flash ROM address FLASH_ADR11.
53	CKE	TTL Output	For non flash mode: SDRAM clock enable. For flash mode: flash ROM address FLASH_ADR10.
54	CLK	TTL Output	SDRAM clock
55-56	RA[11:10]	TTL Output	For non flash mode: DRAM address bus RA[11:10] For flash mode: flash ROM address FLASH_ADR[9:8]
58-64,66-67,69	RA[9:0]	TTL Output	RAM address bus
70	RAS#	TTL Output	RAM row address strobe, low active
71	ROE#	TTL Output	RAM output enable, low active. It must be pulled with 20K resistor if flash mode is used.

Pin Numbers	Pin NAME	Type	Description
72	RWE#	TTL Output	RAM write enable, low active. When two write enable pins are used, it only for low byte.
73	CASH#/RWEH#	TTL Output	High column address strobe: Write enable High Byte Multi-function pin: low active RAM column address strobe for high byte, when two column address strobe pins are used. Write enable for high byte, when two write enable pins are used.
74	CAS#	TTL Output	World RAM column address strobe: Low column address strobe Multi-function pin: low active RAM column address strobe for a word, when two column address strobe pins are not used. It is used only for low byte, when two column address strobe pins are used.
76-83, 85-87 90-94	RD[15:0]	TTL I/O	RAM data bus
System Clock Interface			
88	IPLLVD	Power	Power pin for system varipitch circuitry.
89	IPLLVSS	Ground	Ground pin for system varipitch circuitry.
Host Interface			
101	DASP#	TTL I/O 50K pull up	Drive active/Slave present This is the time-multiplexed signal that indicates that a device is active, or that slave is present.
102	CS3FX#	TTL Input 50K pull up	Host chip select 2(for 3FXH/37xh) The CX3FX# and CS1FX# are chip select signals from the host used to select the Command Block registers.
103	CS1FX#	TTL Input 50K pull up	Host chip select 1 (for 1Fhx/17xh)
105,108,106	HA[2:0]	TTL Input 50K pull up	Host address bus This is the 3-bit binary coded address asserted by the host to access a register or data port in the device.
107	PDIAG#	TTL I/O 50K pull up	Passed diagnostics
110	IOCS16#	TTL Output Open drain	I/O 16-bit chip select
111	INTRQ	TTL Output	Host interrupt. The MT1368 uses this signal to interrupt the host system.
112	DMACK#	TTL Input 50K pull up	DMA acknowledge. This signal shall be used by the host in response to DMAREQ to initiate DMA transfers.
113	IORDY	TTL Output	I/O channel ready: Ultra DMA ready: Ultra DMA data strobe. This is a multi-function pin. For i/o channel Ready, this signal is negated to extend the host transfer cycle of any register read or write when the device is not able to complete the transfer. For Ultra DMA Ready, this signal is asserted by the device to indicate to the host that the device is ready to receive Ultra DMA data out bursts from the host. For Ultra DMA data strobe, this is the data in strobe signal from device for Ultra DMA data in burst to host.
114	DIOR#	TTL Input 50K pull up	Device I/O read: Ultra DMA ready: Ultra DMA data strobe. This is multi-function pin. For Device I/O Read, this signal is the strobe signal asserted by the host to read device registers or the data port. For Ultra DMA read, this is asserted by the host to indicate to the device that the host is ready to receive Ultra DMA data in burst to host For Ultra DMA data strobe, this signal is the data out strobe signal from the host for an Ultra DMA data out burst.

Pin Numbers	Pin NAME	Type	Description
116	DIOW#	TTL Schmitt Input 50K pull up	Device I/O write: Stop Ultra DMA burst This is multi-function pin. For Device I/O Write, this signal is the strobe signal asserted by the host to write device registers or the data port. For Stop Ultra DMA, this signal shall be negated by host before data is transferred in an Ultra DMA burst and is asserted by host during an Ultra DMA burst to signal the termination of Ultra DMA burst.
117	DMARQ	TTL Output	DMA request. This signal is used for DMA data transfers between host and device and it shall be asserted by the MT1368 when it is ready to transfer data to or from the host. The direction of data transfer is controlled by DIOR# and DIOW#.
118-120,122-126,-128-131,134-137	HD[15:0]	TTL I/O	Host data bus. This is an 8- or 16- bit bi-directional data interface between the host and device; the lower 8 bits are used for 8-bit register transfers. Data transfers are 16-bit wide.
138	HRST#	TTL Schmitt Input 50K pull up	Host reset. This signal is referred to as hardware reset and it is used by host to reset the MT1368.
CLV/CAV Varipitch interface			
140	VPVDD	Power	Power pin for varipitch VCO circuitry.
141	VCOCIN	Analog Input	Connect capacitor for compensator loop filter.
142	VPVSS	Ground	Ground pin for varipitch VCO circuitry.
Miscellaneous			
139	PRST#	TTL Schmitt Input 50K pull up	Power-on reset, low active
143	TEST	TTL Input 50K Pull-Down	Test mode control pin, high active
Lag and Programmable I/O Interface			
145	FLAGD	TTL I/O	Servo DSP flag.
146	FLAGC	TTL I/O	Servo DSP flag.
147	FLAGB	TTL I/O	Servo DSP flag.
148	FLAGA	TTL I/O	Servo DSP flag. The internal flags of servo DSP can be selected to output through FLAGA, FLAGB, FLAGC, and FLAGD pins. To program the selection the micro controller must write FLGMOD register.
150	IO3	TTL I/O 50K pull high	At non-flash mode: programmable I/O or internal non-servo flags output. At flash mode cycle: to monitor DSVSEL to device master or slaver. It is recorded on DEVSEL <sub>102hRW6</sub> .
151	IO2	TTL I/O 50K pull high	At non-flash mode cycle: programmable I/O or internal non-servo flags output. At flash mode cycle: flash ROM address FLASH_ADR16.
152	IO1	TTL I/O	At non-flash mode cycle: programmable I/O or internal non-servo flags output. At flash mode cycle: flash ROM output enable FLASH_OE#.
153	IO0	TTL I/O 50K pull high	At non-flash mode cycle: programmable I/O or internal non-servo flags output. At flash mode cycle: flash ROM write enable FLASH_WR#.
SIO interface & Defect			
154	SDATA	TTL I/O	RF serial data input/output.
155	SDEN	TTL output	RF serial data latch enable
156	SLCK	TTL output	RF serial clock output
157	BDO	TTL Input 50K pull down	Flag of defect data input status
Digital Power & Ground			
57,75,104,144	DVDD3	Power	+3.3V use for Internal digital circuitry and digital output pad
16,65,109,133,100	DVDD	Power	+5V use for Internal digital circuitry and digital output pad
21,35,68,84,115,121,127,133,149,96	DVSS	Ground	Internal digital circuitry and digital output pad.

# D1870 BLOCK DIAGRAM

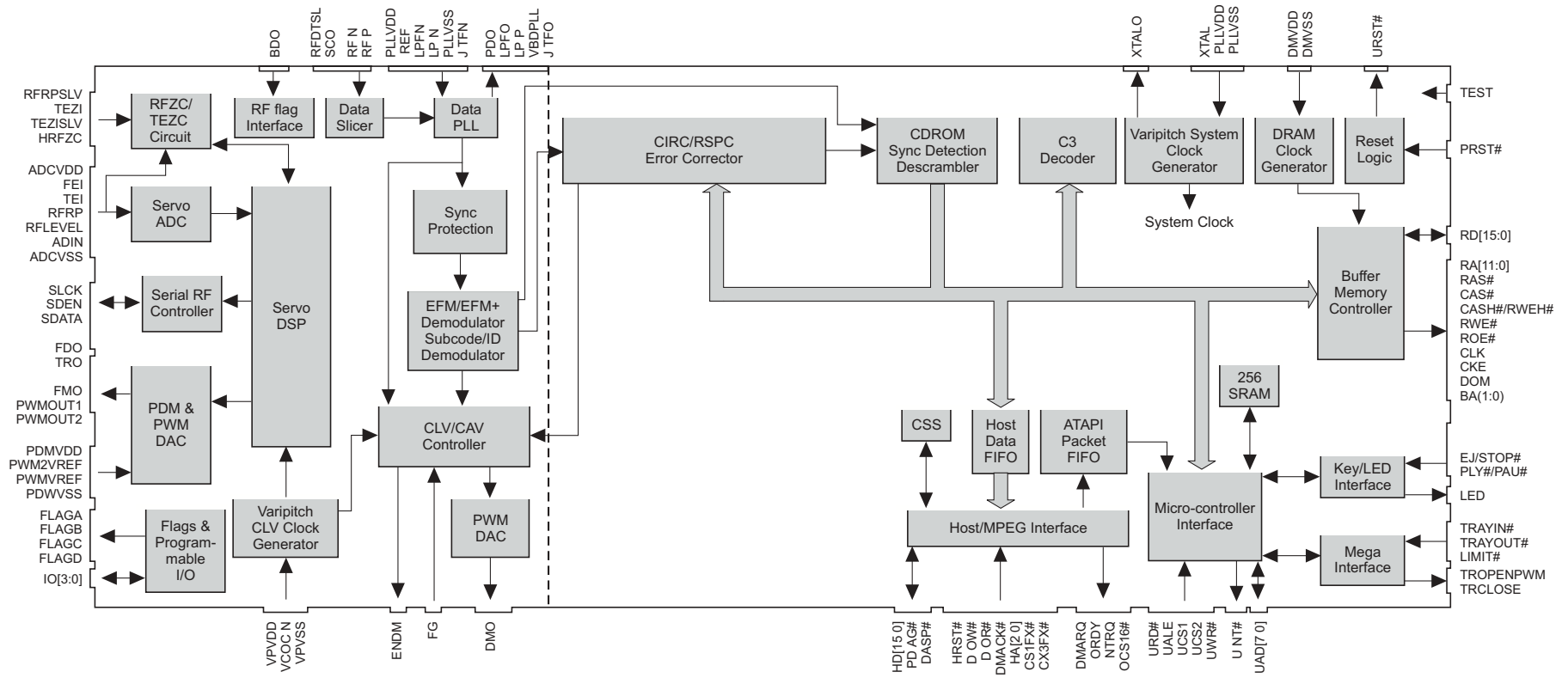

## VS3811 PIN ASSIGNMENTS

Name	Number	I/O	Definition
VCC	1,9,18,27,35,44,51,59,68,75,83,92,99, 104, 111,121,130,139,148,157,164, 172, 183, 193,201	I	3.6 V power supply.
LA[21:0]	23:19,16:10,7:2,207:204	O	Device address output.
VSS	8,17,26,34,43,52,60,67,76,84,91,98,103,112,120,129,138,147,156,163,171, 177,184,192,200,208	I	Ground.
RESET#	24	I	Reset input, active low.
TDMDX RSEL	25	O	TDM transmit data.
		I	ROM Select RSEL Selection 0 16-bit ROM 1 8-bit ROM
TDMDR	28	I	TDM receive data.
TDMCLK	29	I	TDM clock input.
TDMFS	30	I	TDM frame synch.
DMTSC#	31	O	TDM output enable, active low.
TWS	32	O	Audio transmit frame sync.
SEL PLL[2:0]	33	I	Select Pll1. SEL-PLL2 SEL-PLL0 Clock Output 0 0 2.5*DCLK 0 1 3*DCLK 1 0 3.5*DCLK 1 1 4*DCLK
TSD[3:0]	38,37,36,33	O	Audio transmit serial data port.
MCLK	39	I/O	Audio master clock for audio DAC.
TBCK	40	I/O	Audio transmit bit clock.
SPDIF DOB M	41	O	S/PDIF (IEC958) Format Output.
RSD	45	I	Audio receive serial data.
RWS	46	I	Audio receive frame synch.
RBCK	47	I	Audio receive bit clock.
APLLCAP	48	I	Analog PLL Capacitor.
XIN	49	I	Crystal input.
XOUT	50	O	Crystal output.
DMA[11:0]	66:61,58:53	O	DRAM address bus.
DCAS#	69	O	Column address strobe, active low.
DOE#	70	O	Output enable, active low.
DSCK EN		I	Clock Enable, active low.
DWE#	71	O	DRAM write enable, active low.
DRAS[2:0]#	74:72	O	Row address strobe, active low.

Name	Number	I/O	Definition
DB[15:0]	96:93,90:85,82:77	I/O	DRAM data bus.
DCS[1:0]#	97,100	O	SDRAM chip select [1:0], active low
DQM	101	O	Data input/output mask.
DSCK	102	O	Clock to SDRAM.
DCLK	105	I	Clock Input (27 MHz)
YUV[7:0]	115:113,110:106	O	8-bit YUV output.
PCLK2XSCN	116	I/O	2X pixel clock.
PCLKQSCN	117	I/O	Pixel clock.
VSYNCH#	118	I/O	Vertical synch for screen video interface, programmable for rising or falling edge, active low.
HSYNCH#	119	I/O	Horizontal sync for screen video interface, programmable for rising or falling edge, active low.
HD[15:0]	141:140,137:131,128:122	O	Host data bus
HCS1FX#	152	O	Host select 1.
HCS3FX#	153	O	Host select 3.
HIOCS16#	151	I	Device 16-bit data transfer.
HA[2:0]	158,155:154	I/O	Host address bus.
VPP	159	I	Peripheral protection voltage. See App Note 2.
HWR#/DCI_ACK#	149	I,O	Host write/DCI Interface Acknowledge Signal, active low.
HRD#/DCI_CLK	150	O, O	Host read/DCI Interface Clock.
HD[15:0]	141:140,137:131,128:122	I/O	Host data bus.
HWRQ#	142	O	Host write request.
HRDQ#	143	O	Host read request.
HIRQ	144	I/O	Host interrupt.
HRST#	145	O	Host reset.
HIORDY	146	I	Host I/O ready
AUX[7:0]	169:165,162:160	I/O	Auxiliary ports.
LOE#	170	O	Device output enable, active low.
LCS[3:0]#	176:173	O	Chip select [3:0], active low.
LD[15:0]	197:194,191:185,182:178	I/O	Device data bus.
LWRLL#	198	O	Device write enable, active low.
LWRHL#	199	O	Device write enable, active low.
NC	37,38,42,203:202		No Connect pins. Leave open.

# VS3811 BLOCK DIAGRAM

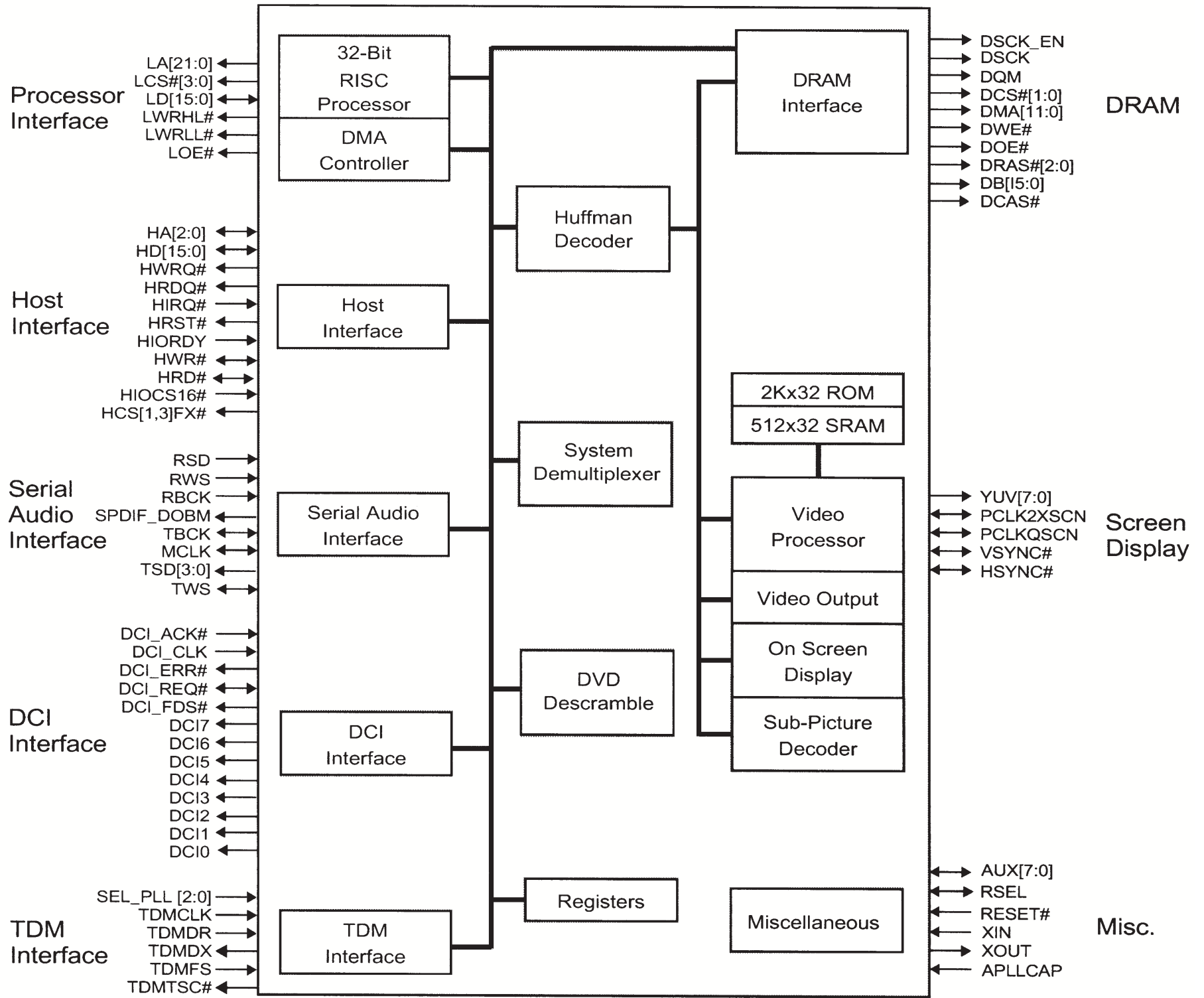



## CS4955 PIN ASSIGNMENTS

PIN NAME	NUMBER	TYPE	DEFINITION
V[7:0]	8,7,6,5,4,3,2,1	IN	Digital video data inputs
CLK	29	IN	27MHz input clock
PADR	16	IN	Address enable line
XTAL-IN	15	IN	Sub-carrier crystal input
XTAL-OUT	14	OUT	Sub-carrier crystal output
HSYNC/CB	10	I/O	Active low horizontal sync, or composite blank signal
VSYNC	11	I/O	Active low vertical sync
FIELD/CB	9	OUT	Video field ID. Selectable polarity or composite blank
RD	27	IN	Host parallel port read strobe, active low
WR	28	IN	Host parallel port write strobe, active low
PDAT[7:0]	19,20,21,22,23,24,25,26	I/O	Host parallel port/general purpose I/O
SDA	32	I/O	I C data
SCL	33	IN	I C clock input
CVBS	44	CURRENT	Composite video output
Y	48	CURRENT	Luminance analog output
C	47	CURRENT	Chrominance analog output
R	39	CURRENT	Red analog output
G	40	CURRENT	Green analog output
B	43	CURRENT	Blue analog output
VREF	38	I/O	Internal voltage reference output external reference input
SET	37	CURRENT	DAC current set
TTXDAT	30	IN	Teletext data input
TTXRQ	31	OUT	Teletext request output
INT	12	OUT	Interrupt output, active high
RESET	34	IN	Active low master RESET
TEST	13	IN	Test pin. Ground for normal operation
VAA	36,41,46	PS	+5V or +3.3Vsupply(must be same as VDD)
GNDD	18	PS	Ground
VDD	17	PS	+5V or +3.3Vsupply(must be same as VAA)
GNDA	35,42,45	PS	Ground

## CS4955 BLOCK DIAGRAM

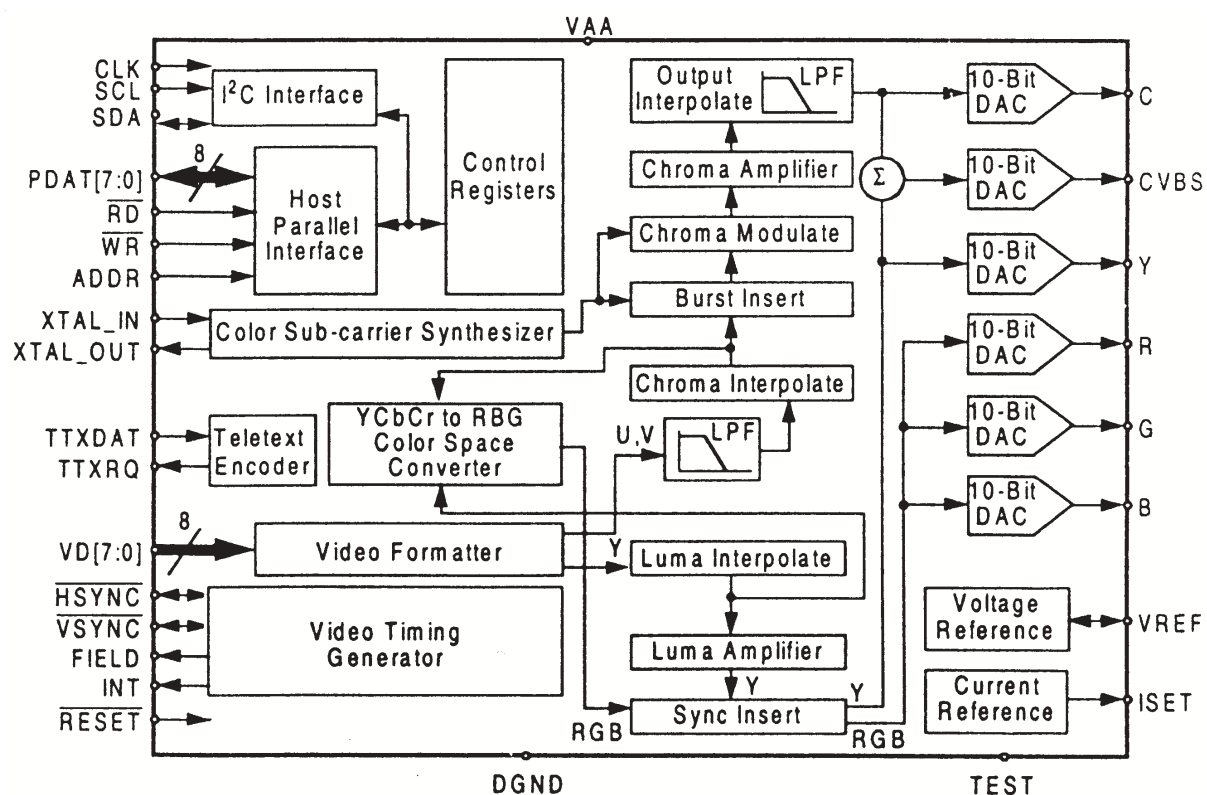

## PCM1723 PIN ASSIGNMENTS

PIN NAME	NUMBER	TYPE	DEFINITION
XTI	1	IN	Master clock input
SCKO	2	OUT	System Clock Out. This output is 256fs or 384fs. System clock generated by the internal PLL.
VCP	3	PWR	PLL Power Supply (+5v)
NC	4	N/A	No connection
MCKO	5	OUT	Buffered clock output of crystal oscillator
ML	6	IN	Latch for serial control data
MC	7	IN	Clock for serial control data
MD	8	IN	Data for serial control
RSTB	9	IN	Reset input. When this pin is low, the digital filters and modulator are held in reset
ZERO	10	OUT	Zero Data Flag. This pin is low when the input data is continuously zero for more than 65.535 cycles of BCKIN
VOU <sub>TR</sub>	11	OUT	Right Channel Analog Output
AGND	12	GND	Analog Ground
VCC	13	PWR	Analog Power Supply(+5v)
VOU <sub>TL</sub>	14	OUT	Left Channel Analog Output
CAP	15		Common pin for analog output amplifiers
BCKIN	16	IN	Bit clock for clocking in the audio data
DIN	17	IN	Serial audio data input
LRCIN	18	IN	Left/Right Word Clock. Frequency is equal to fs
NC	19	N/A	No connection
RES	20	N/A	Reserved for factory use, do not connect
VDD	21	PWR	Analog Power Supply(+5v)
DGND	22	GND	Digital Ground
PGND	23	GND	PLL Ground
XTO	24	OUT	Crystal oscillator output

Note: (1) Schmitt trigger input with internal pull-up resistors.  
 (2) Schmitt trigger input.

## PCM1723 BLOCK DIAGRAM

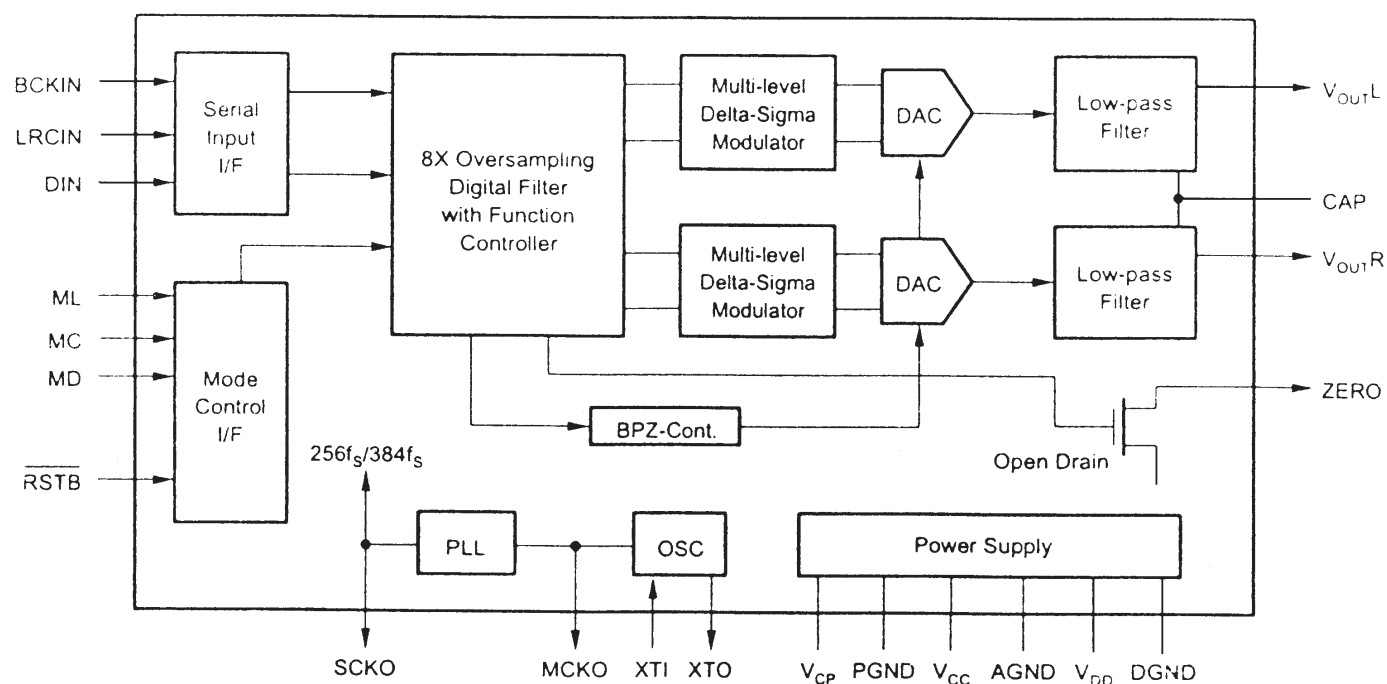

## BA6208 EQUIVALENT CIRCUIT DIAGRAM

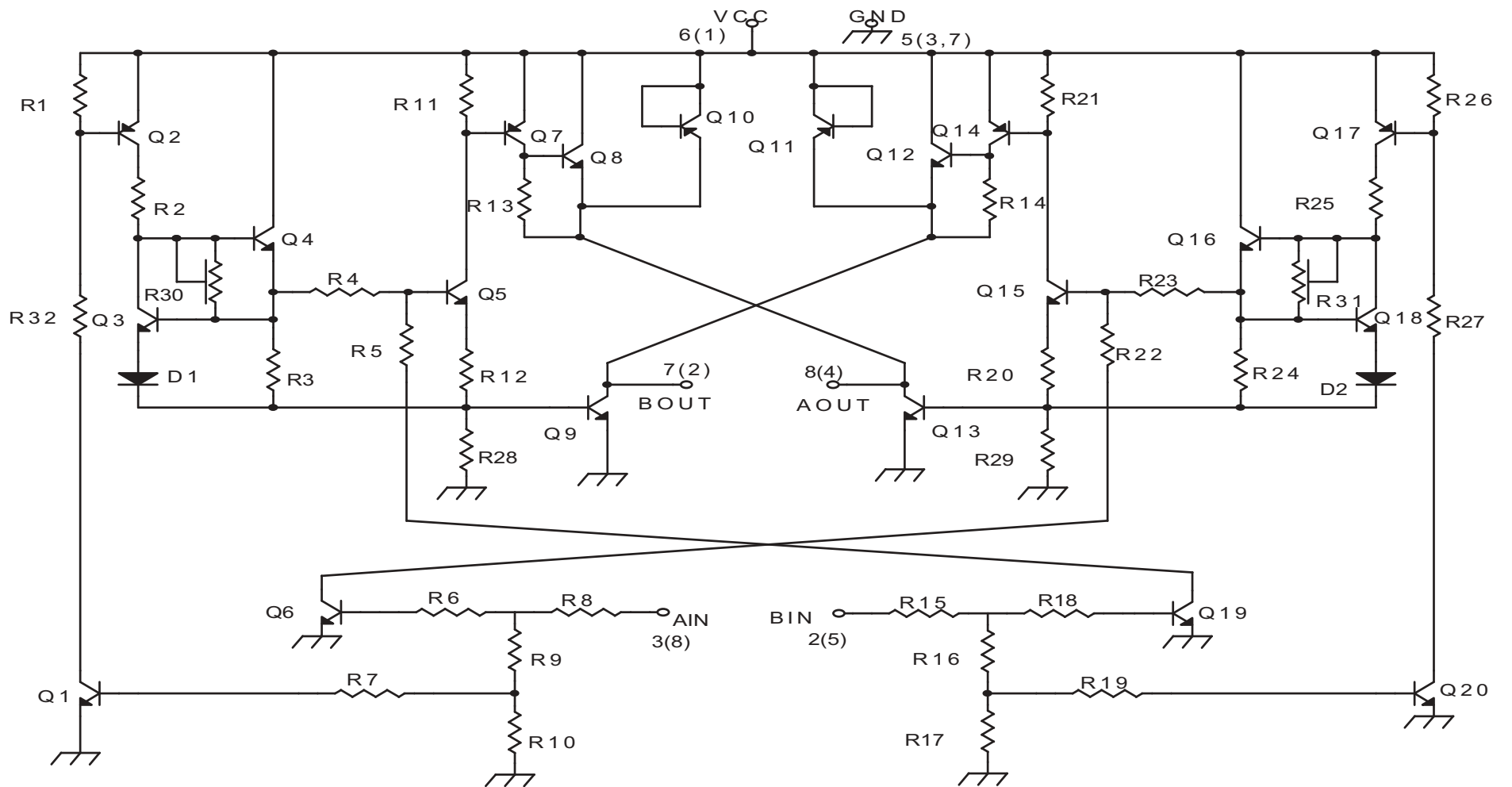

NOTE : Figures in parentheses are for the BA6208F

## BA6208 INPUT/OUTPUT TRUTH TABLE

AIN	BIN	AOUT	BOUT
H	L	H	L
L	H	L	H
H	H	L	L
L	L	OPEN	OPEN

## BA6208 EXTERNAL DIMENSIONS

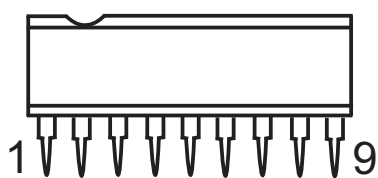

BA6208

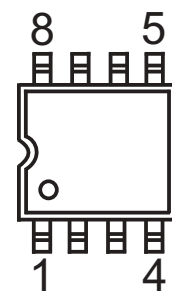

BA6208F

**NJW1104**  
**SYSTEM BLOCK DIAGRAM**

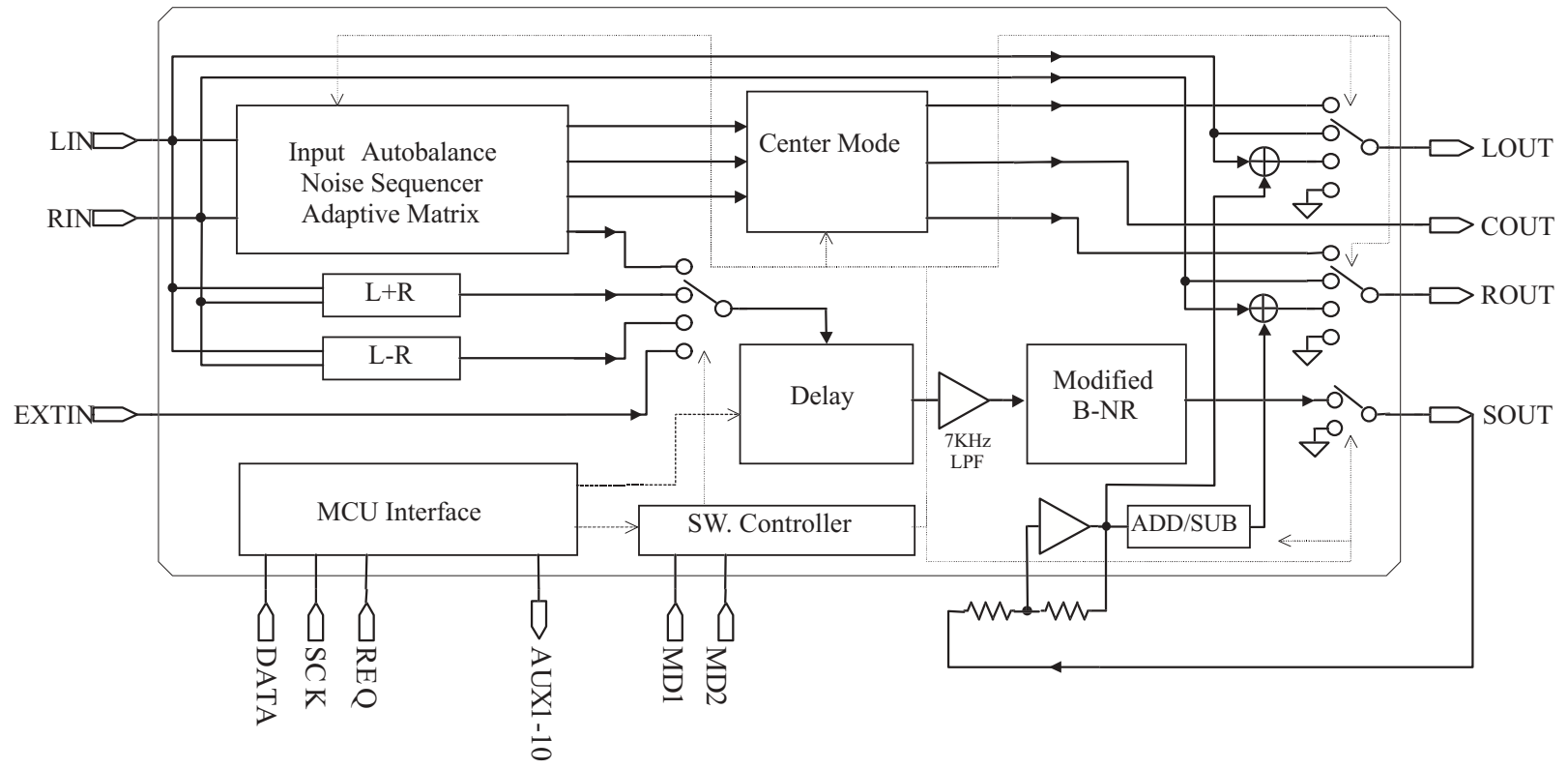

# NJW1104

## APPLICATION CIRCUIT AND BLOCK DIAGRAM

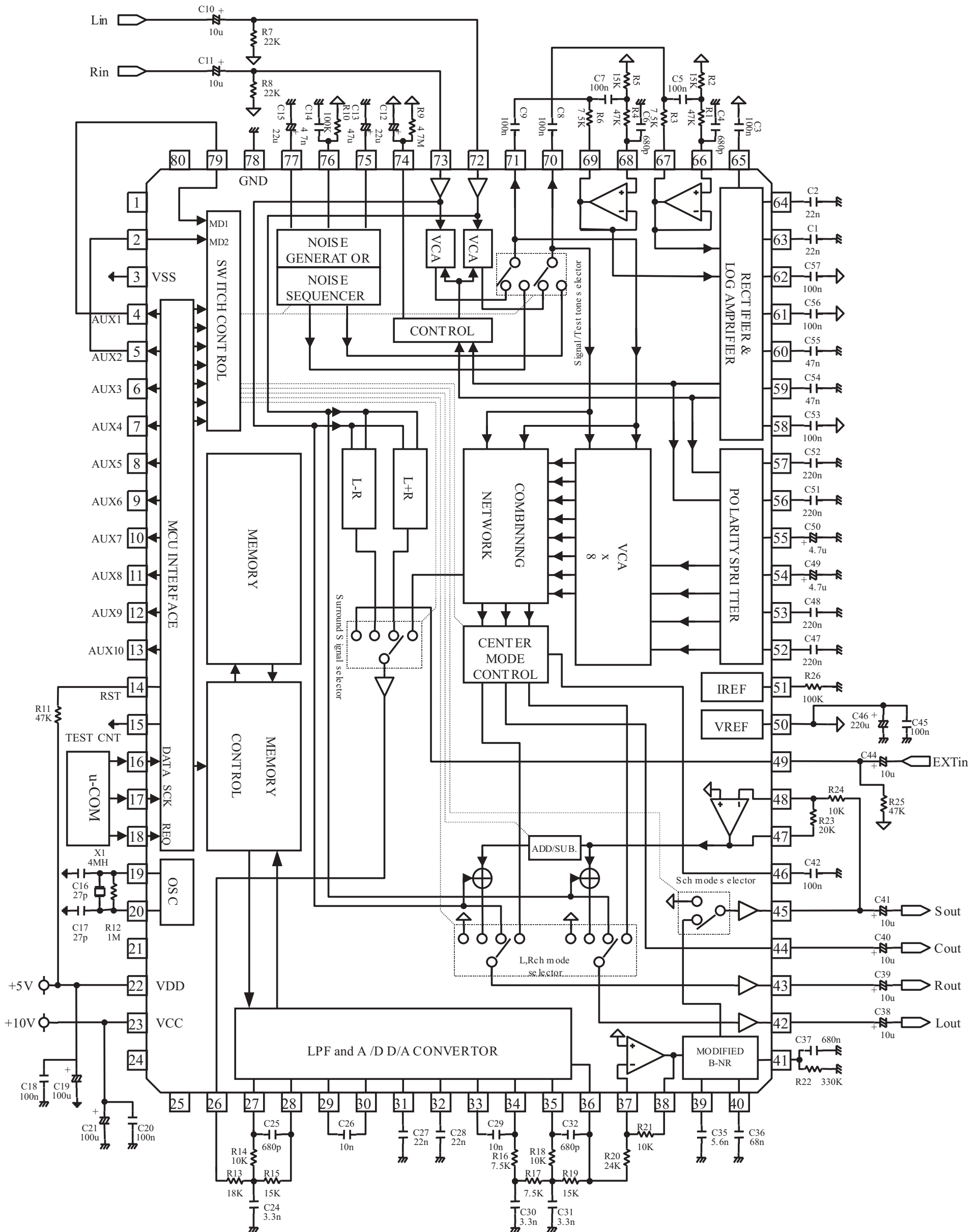

# PRINTED CIRCUIT

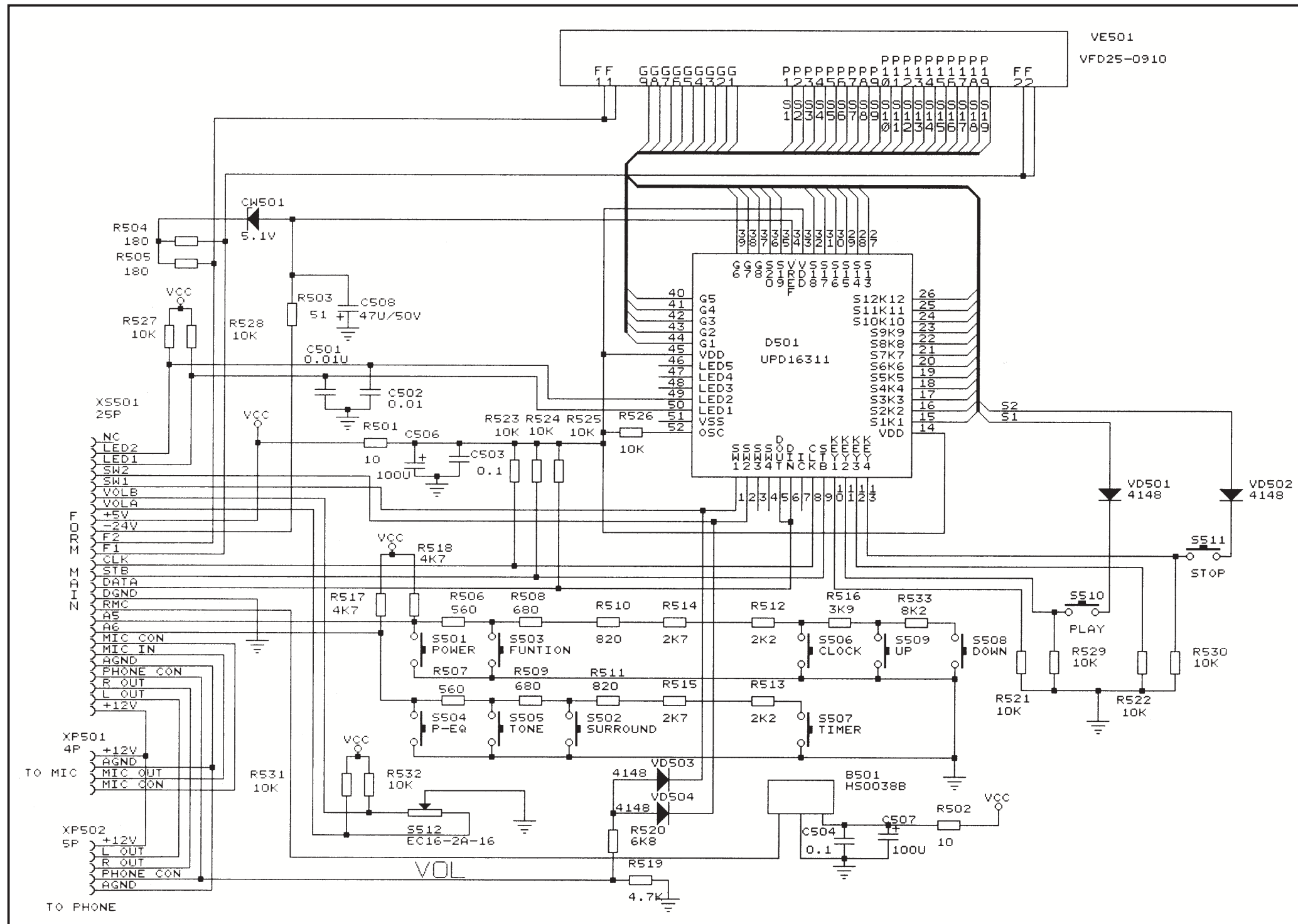

A750 KEY CIRCUIT

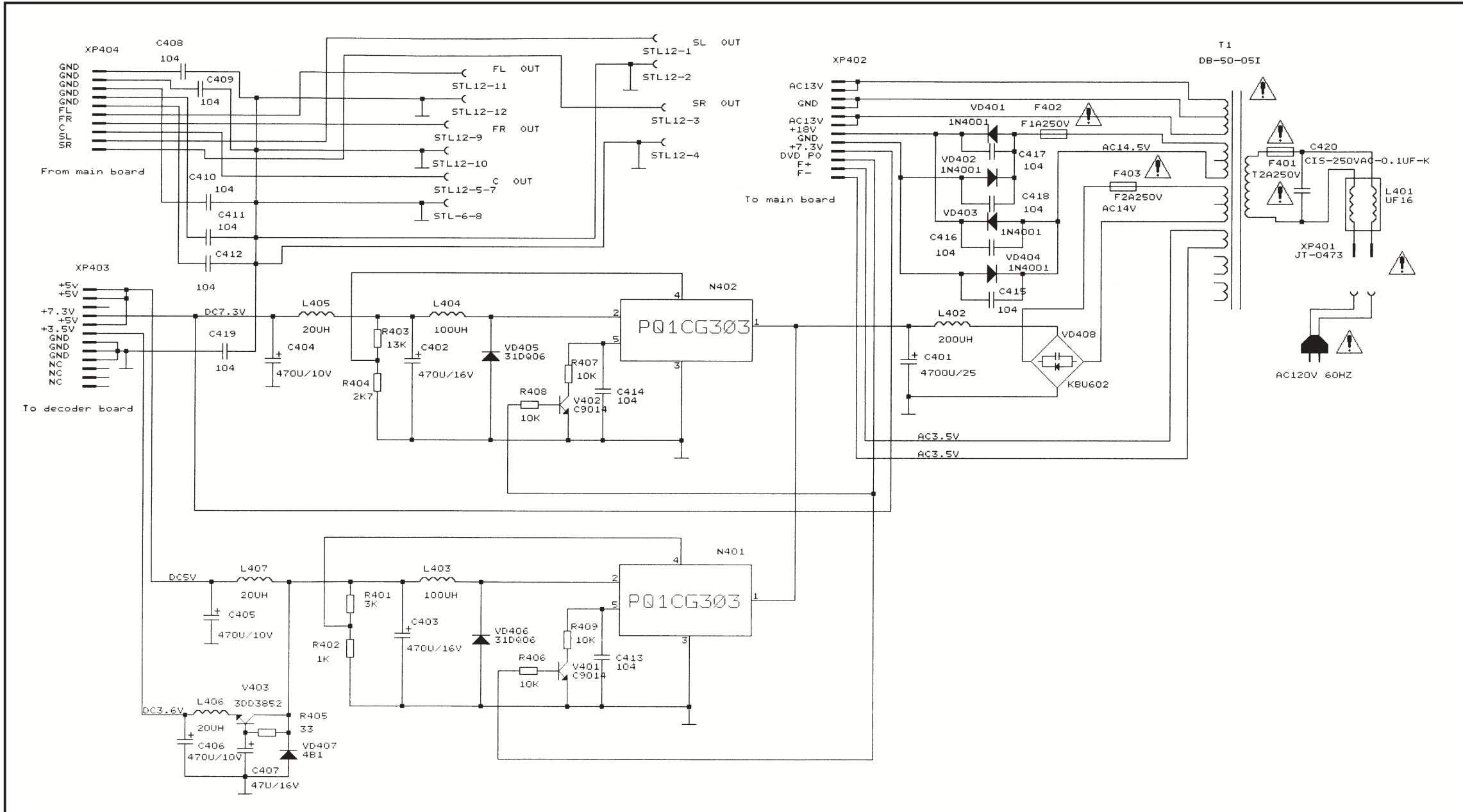

A750 POWER CIRCUIT

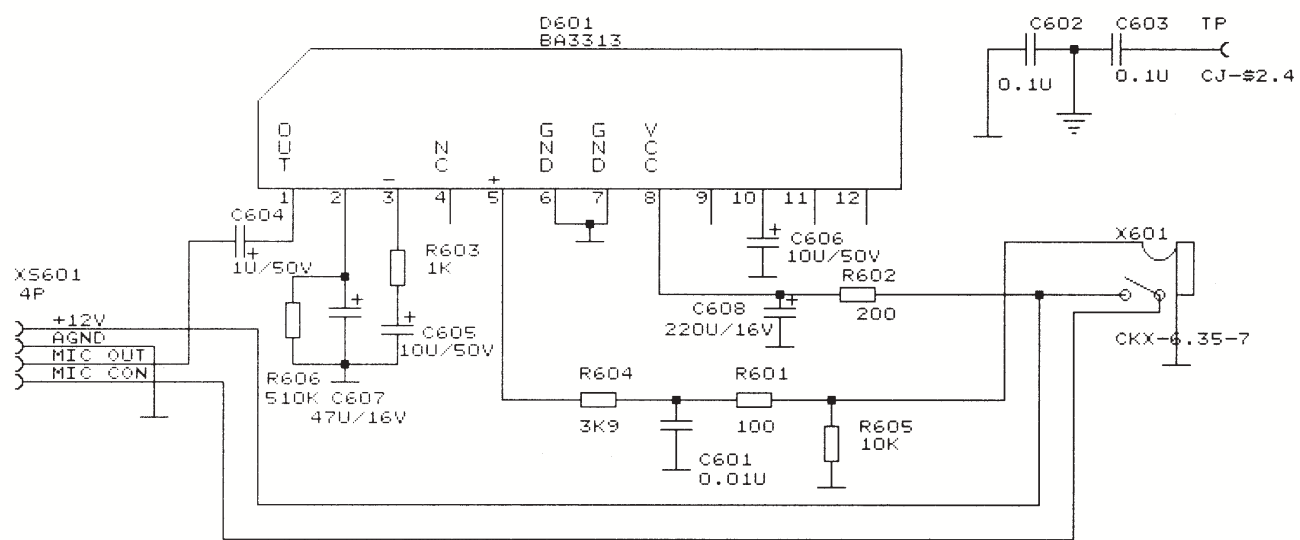

A750 MIC CIRCUIT

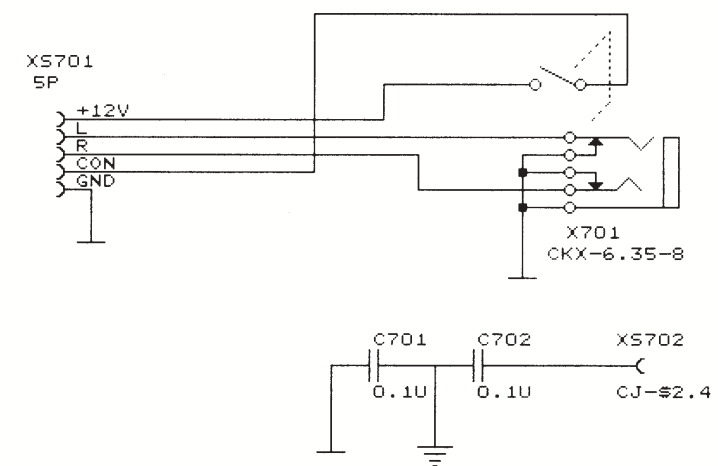

A750 PHONE CIRCUIT



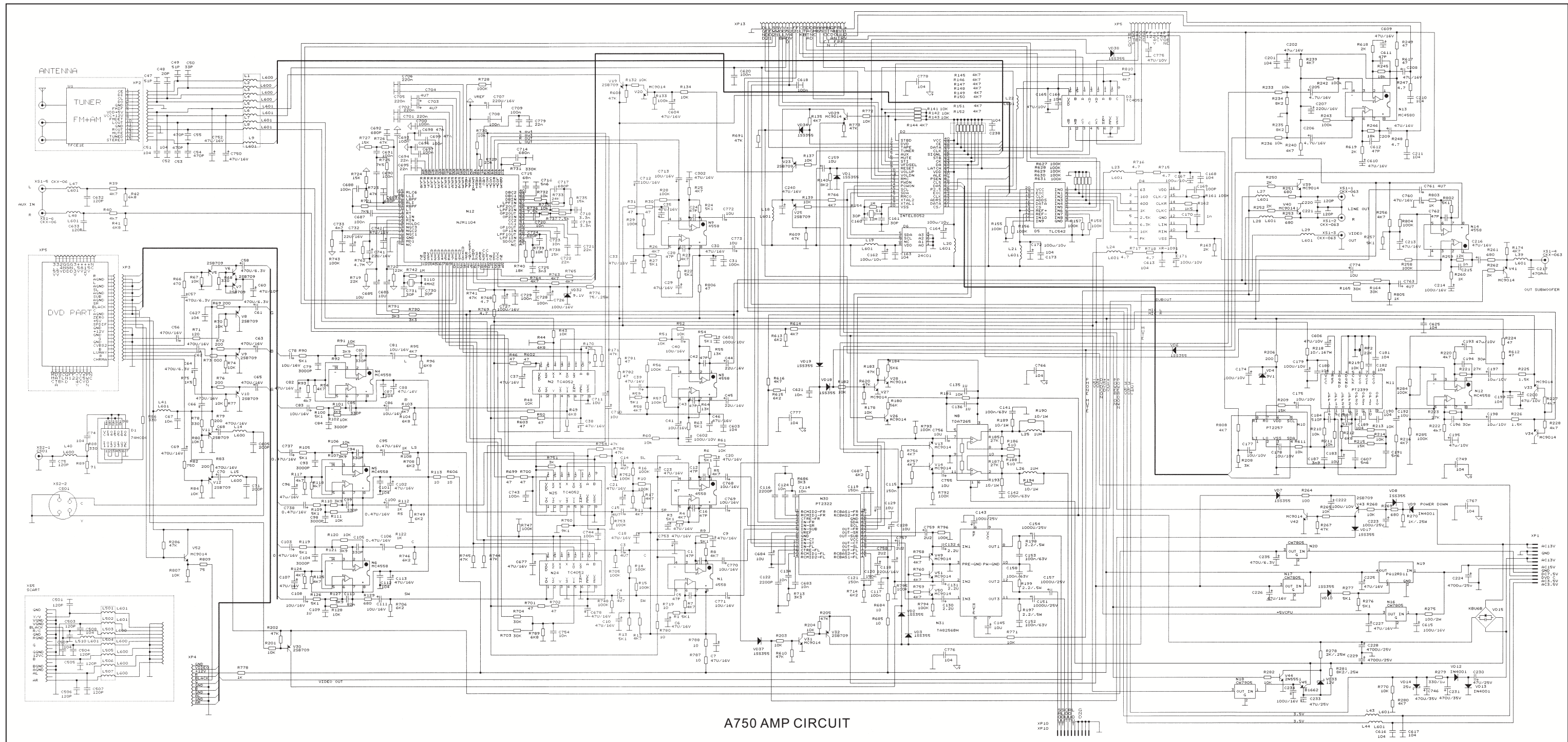

A750 AMP CIRCUIT

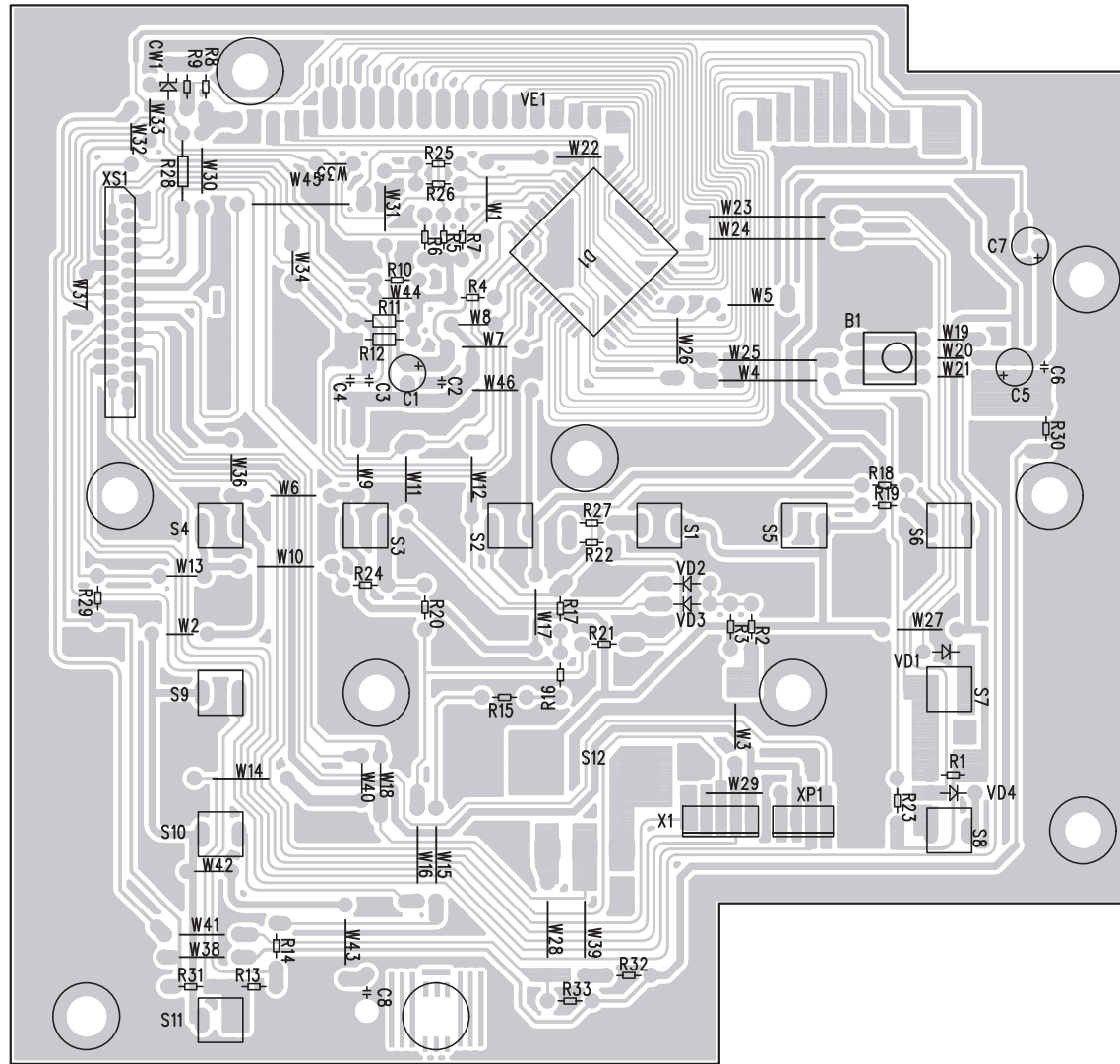

A750 KEY BOARD

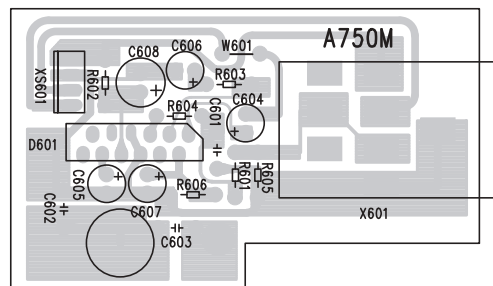

A750 MIC BOARD

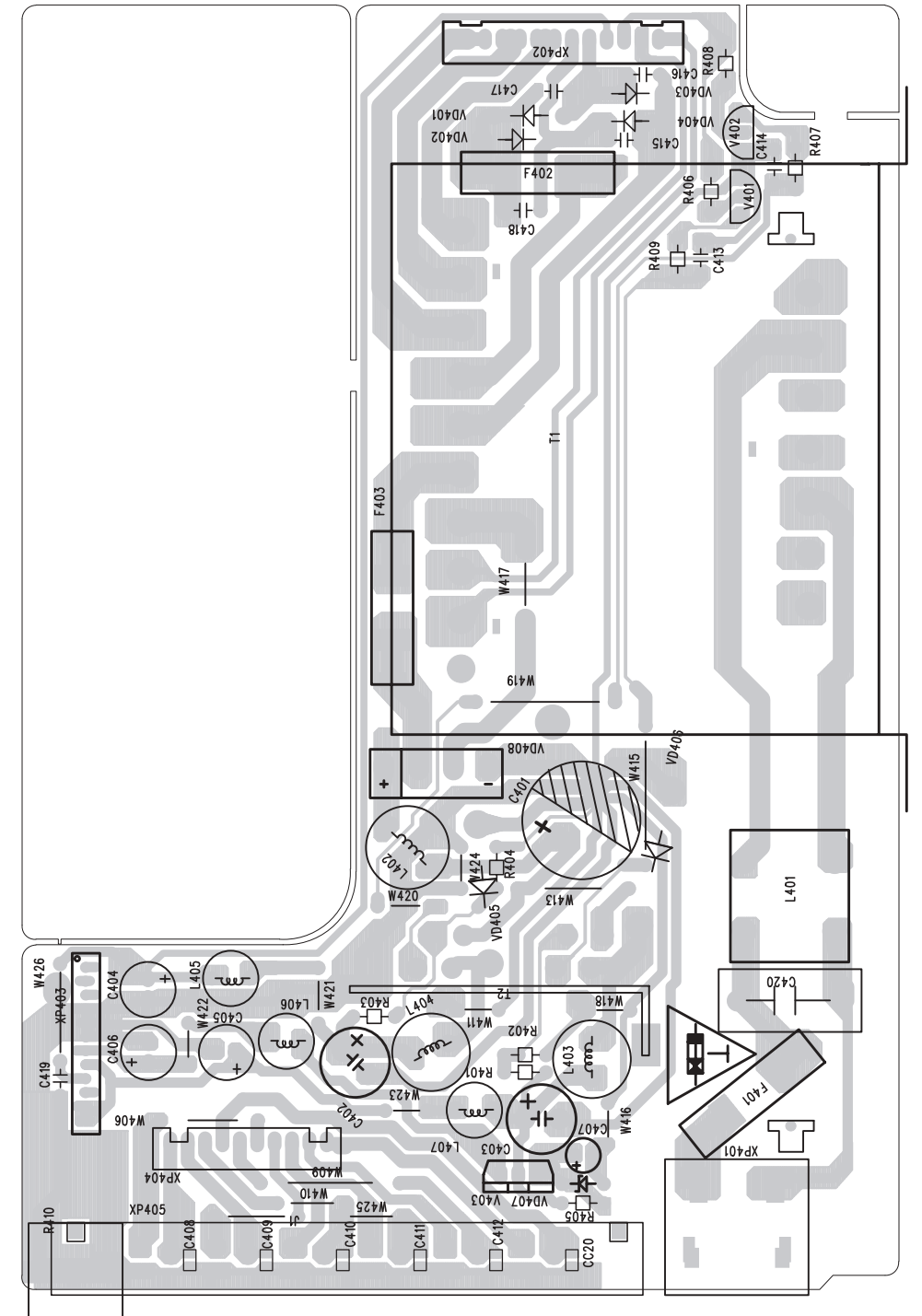

A750 POWER BOARD

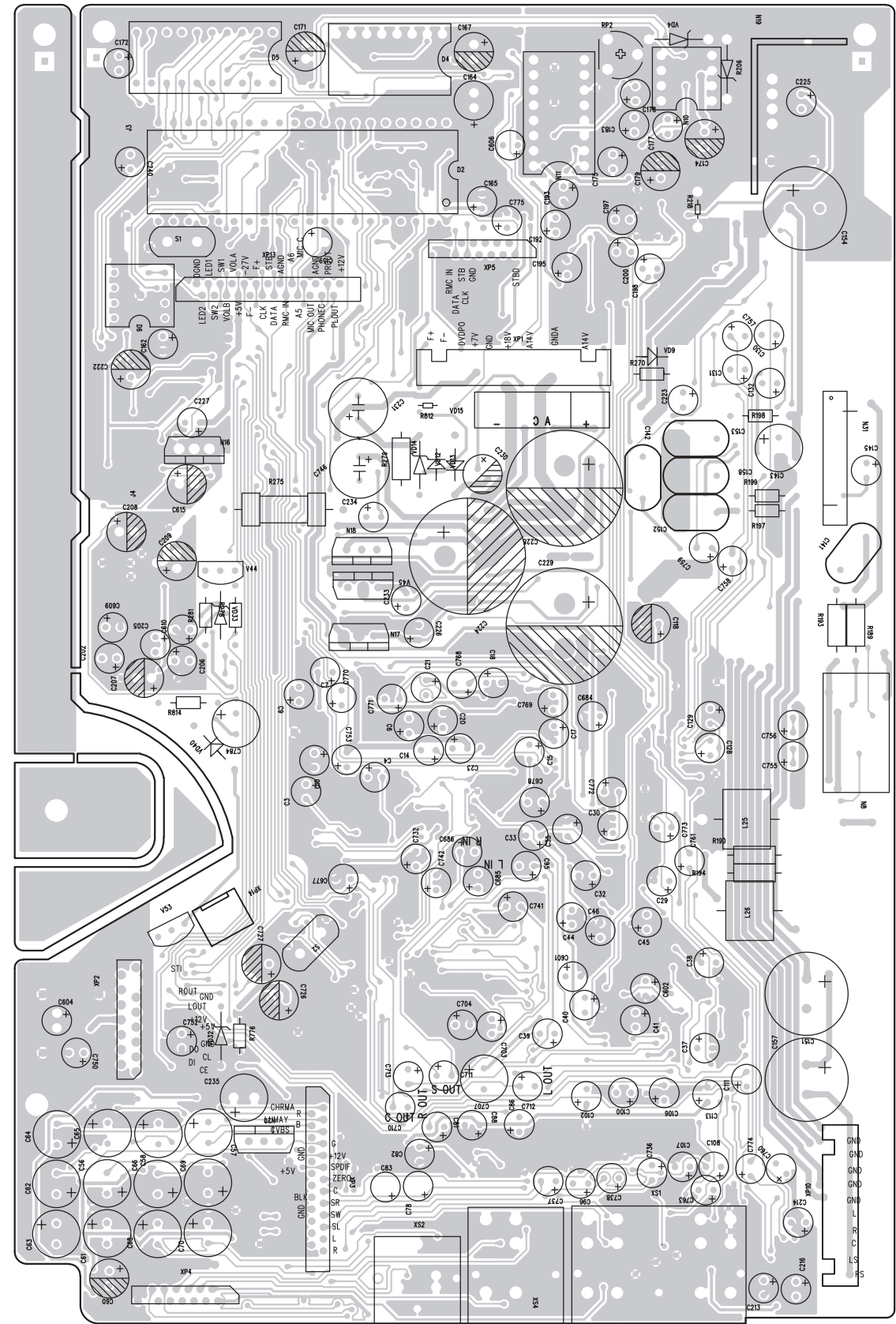
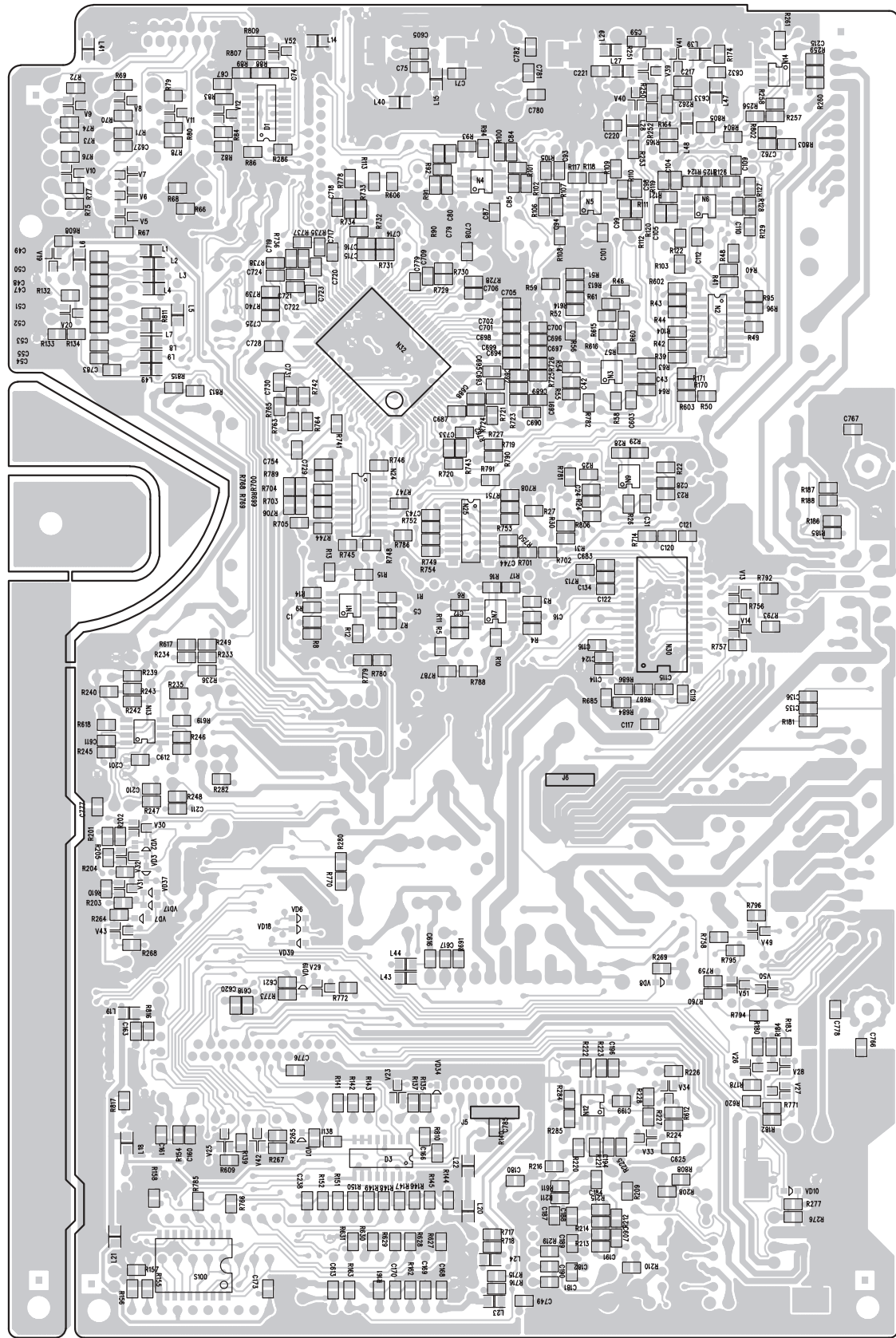

A750AMP BOARD

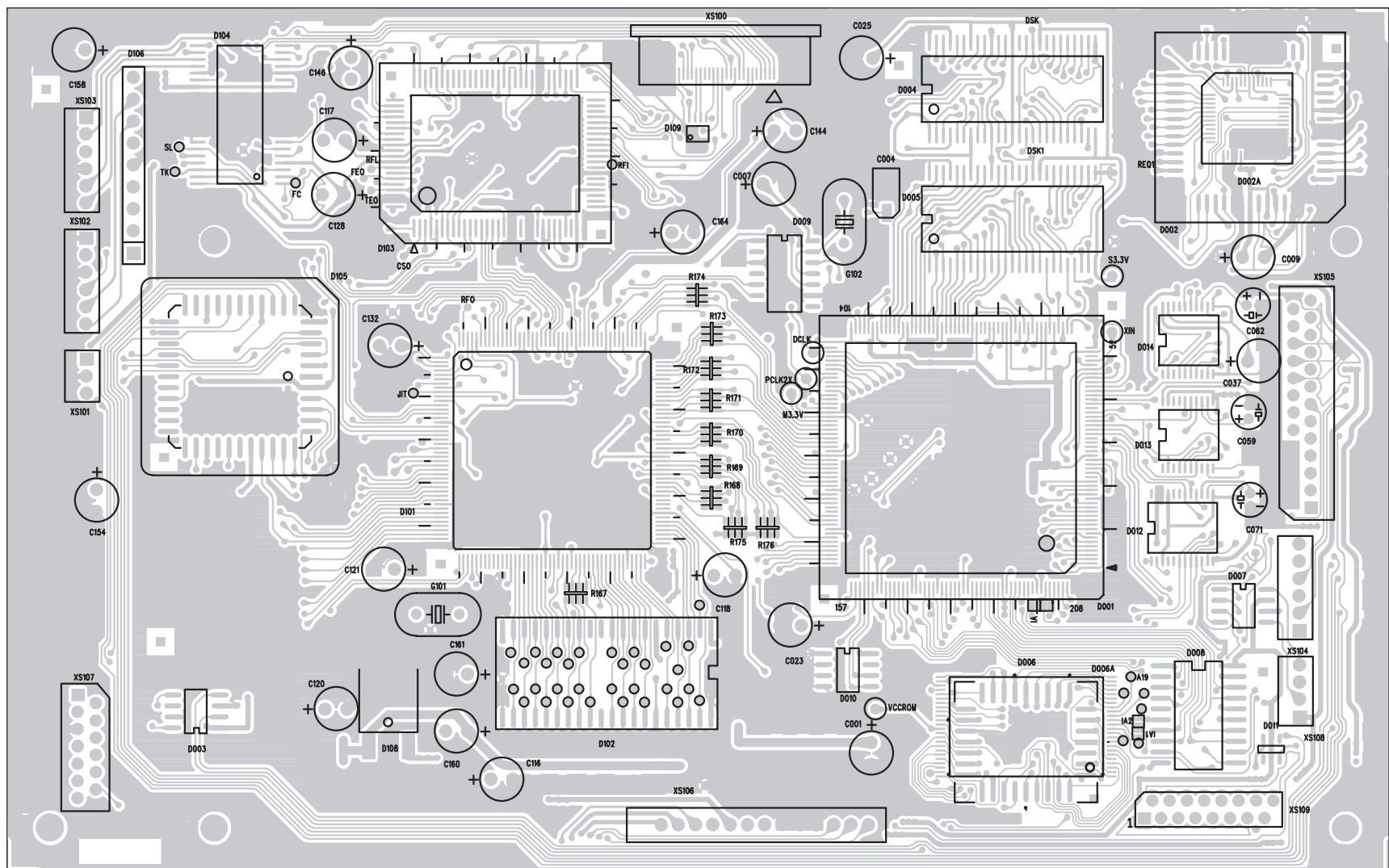
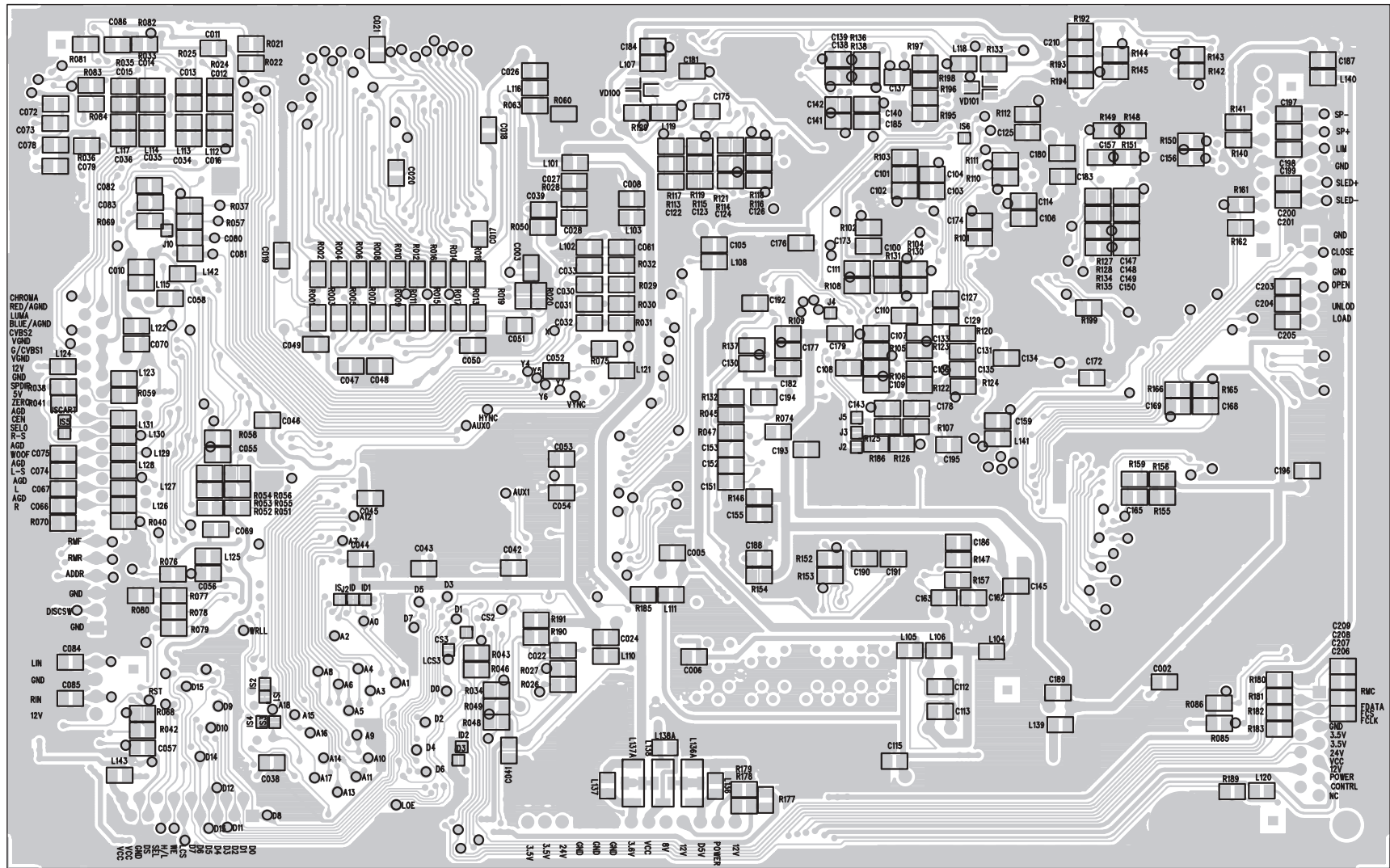

DSM750 DECODER BOARD

# ELECTRICAL PARTS LIST

PART No.	PART NAME	Q'TY
<b>DVD750(Aussie)</b>		
b0882	A750AMP ASS'Y	1
bS7100-1	DVD-750 POWER ASS'Y	1
b1053-1	A750 KEY ASS'Y	1
bS7091-1	A750 MIC ASS'Y	1
b0883	DSM750 DECODER ASS'Y	1
bS8001	KHM-232B LOADING ASS'Y	1
S0549b	A750 TRANSFORMER	1
S3284	CC-1.0×25×150	1
S3145a	CC-1.0×12×140(B=6)	1
S3287	CC-0.5×24×185	1
S3288	CC-1.25×15×115	1
S3278	A750AMP OUTPUT WIRE	1
S3279	A750 OPEN/CLOSE WIRE	1
S3281	A750 LOADING WIRE	1
S3282	A750 TRANSFORMER WIRE	1
S3283	A750 DECODER POWER WIRE	1
S0689b	RC-750 REMOTE	1
S2701	7# BATTERY	2
bS4309	TUNER TFCE1E	1
S1355a	A750 OWNER MANUAL	1
S3021	RCA CORD AUDIO	1
S4308	A300 FM ANTENNA	1
S3022	RCA CORD VIDEO	1
S3023	S-VIDEO WIRE	1
S3339a	A750 POWER CDRD	1
S0550	213LOAD SWITCH	1
S8022	FAN C140EL10G8310	1

<b>PART No.</b>	<b>PART NAME</b>	<b>Q'TY</b>
<b>DVD750(S. Africa)</b>		
b0882	A750AMP ASS'Y	1
bS7100-1	DVD-750 POWER ASS'Y	1
b1053-1	A750 KEY ASS'Y	1
bS7091-1	A750 MIC ASS'Y	1
b0883	DSM750 DECODER ASS'Y	1
bS8001	KHM-232B LOADING ASS'Y	1
S0549a	A750 TRANSFORMER	1
S3284	CC-1.0×25×150	1
S3145a	CC-1.0×12×140(B=6)	1
S3287	CC-0.5×24×185	1
S3288	CC-1.25×15×115	1
S3278	A750AMP OUTPUT WIRE	1
S3279	A750 OPEN/CLOSE WIRE	1
S3281	A750 LOADING WIRE	1
S3282	A750 TRANSFORMER WIRE	1
S3283	A750 DECODER POWER WIRE	1
S0689b	RC-750 REMOTE	1
S2701	7# BATTERY	2
S4309	TUNER TFCE1E	1
S1355a	A750 OWNER MANUAL	1
S3021	RCA CORD AUDIO	1
S4308	A300 FM ANTENNA	1
S3022	RCA CORD VIDEO	1
S3023	S-VIDEO WIRE	1
S3339	A750 POWER CDRD	1
S0550	213LOAD SWITCH	1
S8022	FAN C140EL10G8310	1

REF No.	PART No.	PART NAME
<b>A750 KEY ASS'Y</b>		
RESISTOR		
R501	G0705	RT13-0.167W-10
R502	G0705	RT13-0.167W-10
R503	G0709	RT13-0.167W-51
R504	G0714	RT13-0.167W-180
R505	G0714	RT13-0.167W-180
R506	G0776	RT13-0.167W-560
R507	G0776	RT13-0.167W-560
R508	G0778	RT13-0.167W-680
R509	G0778	RT13-0.167W-680
R510	G0779	RT13-0.167W-820
R511	G0779	RT13-0.167W-820
R512	G0722	RT13-0.167W-2K2
R513	G0722	RT13-0.167W-2K2
R514	G0723	RT13-0.167W-2K7
R515	G0723	RT13-0.167W-2K7
R516	G0726	RT13-0.167W-3K9
R517	G0728	RT13-0.167W-4K7
R518	G0728	RT13-0.167W-4K7
R519	G0728	RT13-0.167W-4K7
R520	G0731	RT13-0.167W-6K8
R521	G0735	RT13-0.167W-10K
R522	G0735	RT13-0.167W-10K
R523	G0735	RT13-0.167W-10K
R524	G0735	RT13-0.167W-10K
R525	G0735	RT13-0.167W-10K
R526	G0735	RT13-0.167W-10K
R527	G0735	RT13-0.167W-10K
R528	G0735	RT13-0.167W-10K
R529	G0735	RT13-0.167W-10K
R530	G0735	RT13-0.167W-10K
R531	G0735	RT13-0.167W-10K
R532	G0735	RT13-0.167W-10K
R533	G0733	RT13-0.167W-8K2
CAPACITOR		
C501	a2051	CT1-63V-0.01+50%-20%
C502	a2051	CT1-63V-0.01+50%-20%
C503	a2056	CS1-63V-0.1u+80%

REF No.	PART No.	PART NAME
C504	a2056	CS1-63V-0.1u+80%
C505	a2056	CS1-63V-0.1u+80%
C506	a3201	CD11CX-16V-100uF±20%
C507	a3201	CD11CX-16V-100uF±20%
OTHER		
VD501	a5004	IN4148
VD502	a5004	IN4148
VD503	a5004	IN4148
VD504	a5004	IN4148
CW501	a1106	2CW-5.1V
S501	G6434	TOUCH 6×6-4.5
S502	G6434	TOUCH 6×6-4.5
S503	G6434	TOUCH 6×6-4.5
S504	G6434	TOUCH 6×6-4.5
S505	G6434	TOUCH 6×6-4.5
S506	G6434	TOUCH 6×6-4.5
S507	G6434	TOUCH 6×6-4.5
S508	G6434	TOUCH 6×6-4.5
S509	G6434	TOUCH 6×6-4.5
S510	G6434	TOUCH 6×6-4.5
S511	G6434	TOUCH 6×6-4.5
S512	a0633	POTENTIOMETER EC16-24-20
D501	P4399	PT6311
B501	a6733	HS0038B
VE501	a6998	VFD25-0910
XS501	a6755	FABSE2552 SOKEN
XP501	a8895	MIC WIRE
XS501	S3275	CC-1.0×25×90
<b>A750 MIC ASS'Y</b>		
RESISTOR		
R601	G0712	RT13-0.167W-100±5%
R602	G0773	RT13-0.167W-200±5%
R603	G0911	RT13-0.167W-1K±1%
R604	G0726	RT13-0.167W-3K9±5%
R605	G0735	RT13-0.167W-10K±5%
R606	G0763	RT13-0.167W-510K±5%
CAPACITOR		
C601	a2051	CT1-63V-0.01+50%-20%
C602	a2056	CS1-63V-0.1u+80%

REF No.	PART No.	PART NAME
C603	a2056	CS1-63V-0.1u+80%
C604	a3627	CD110X-50V-1uF
C605	a3628	CD110X-50V-10uF±20%
C606	a3628	CD110X-50V-10uF±20%
C607	a3635	CD110X-16V-47uF±20%
C608	a3201	CD110X-16V-100uF±20%
OTHER		
D601	a4511	BA3313K
XS601	a6509	B-4B-PH SOCKET
X601	a6651	CKX-6.35-7 JACK
	a7004	PEG CJ-Ø2.4
<b>A750 POWER ASS'Y</b>		
RESISTOR		
R401	G0913	RT13-0.167W-3K±1%
R402	G0911	RT13-0.167W-1K±1%
R403	G0914	RT13-0.167W-13K±1%
R404	G0912	RT13-0.167W-2.7K±1%
R405	G0811	RT13-0.167W-33±5%
R406	G0735	RT13-0.167W-10K±5%
R407	G0735	RT13-0.167W-10K±5%
R408	G0735	RT13-0.167W-10K±5%
R409	G0735	RT13-0.167W-10K±5%
CAPACITOR		
C401	a3525	CD110X-4700uF-M-25V
C402	a3516	CD110X-470uF-M-16V
C403	a3516	CD110X-470uF-M-16V
C404	a3561	CD110-470uF-M-10V
C405	a3561	CD110-470uF-M-10V
C406	a3561	CD110-470uF-M-10V
C407	a3512	CD110-47uF-16V-M
C408	a3304	CT4D-2F4-0.1uF-63V-S
C409	a3304	CT4D-2F4-0.1uF-63V-S
C410	a3304	CT4D-2F4-0.1uF-63V-S
C411	a3304	CT4D-2F4-0.1uF-63V-S
C412	a3304	CT4D-2F4-0.1uF-63V-S
C413	a3304	CT4D-2F4-0.1uF-63V-S
C414	a3304	CT4D-2F4-0.1uF-63V-S
C415	a3304	CT4D-2F4-0.1uF-63V-S
C416	a3304	CT4D-2F4-0.1uF-63V-S

REF No.	PART No.	PART NAME
C417	a3304	CT4D-2F4-0.1uF-63V-S
C418	a3304	CT4D-2F4-0.1uF-63V-S
C419	a3304	CT4D-2F4-0.1uF-63V-S
C420	a3346	CIS-250VAC-0.1uF-K
TRANSISTOR		
V401	a5009	C9014C
V402	a5009	C9014C
V403	a5063	3DD3852
VD401	a5001	IN4001
VD402	a5001	IN4001
VD403	a5001	IN4001
VD404	a5001	IN4001
VD405	a1568	31DQ06
VD406	a1568	31DQ06
VD407	a1104	2CW-4B1
VD408	a4532	KBU602
INDUCTOR		
L401	a6956	UF-16 FILTER
L402	a7006	200uH
L403	a7005	100uH
L404	a7005	100uH
L405	a6272	20uH
L406	a6272	20uH
L407	a6272	20uH
OTHER		
F401	a6678	2A FUSE
F402	a6025	BG×P-I-1A FUSE
F403	a6027	BG×P-I-2A FUSE
XP401	a6960	DZ2P POWER SOCKET
XP402	a6539	B-12B-XH SOCKET
XP403	a6517	B-12B-PH SOCKET
XP404	a6537	B-10B-XH SOCKET
XP405	a6953	STL-12 PEG
N401	a4720	PQ1CG3032RZ
N402	a4720	PQ1CG3032RZ
	a6929	FUSE HOLDER
<b>A750 AMP ASS'Y</b>		
R1	P11032	RC-03K512JT
R3	P11032	RC-03K512JT



REF No.	PART No.	PART NAME
R4	P11031	RC-03K392JT
R5	P11031	RC-03K392JT
R6	P11032	RC-03K512JT
R7	P11031	RC-03K392JT
R8	P11031	RC-03K392JT
R9	P11032	RC-03K512JT
R10	P11012	RC-03K472JT
R11	P11012	RC-03K472JT
R12	P11012	RC-03K472JT
R13	P11032	RC-03K512JT
R14	P11019	RC-03K104JT
R15	P11019	RC-03K104JT
R16	P11019	RC-03K104JT
R17	P11019	RC-03K104JT
R22	P11032	RC-03K512JT
R23	P11012	RC-03K472JT
R24	P11012	RC-03K472JT
R25	P11032	RC-03K512JT
R26	P11031	RC-03K392JT
R27	P11032	RC-03K512JT
R28	P11019	RC-03K104JT
R29	P11019	RC-03K104JT
R30	P11116	RC-03K470JT
R31	P11116	RC-03K470JT
R39	P11012	RC-03K472JT
R40	P11012	RC-03K472JT
R41	P11033	RC-03K682JT
R42	P11033	RC-03K682JT
R43	P11013	RC-03K103JT
R44	P11033	RC-03K682JT
R46	P11116	RC-03K470JT
R48	P11013	RC-03K103JT
R49	P11033	RC-03K682JT
R50	P11116	RC-03K470JT
R51	P11013	RC-03K103JT
R52	P11013	RC-03K103JT
R54	P11032	RC-03K512JT
R55	P11069	RC-03K133JT
R56	P11019	RC-03K104JT

REF No.	PART No.	PART NAME
R57	P11019	RC-03K104JT
R58	P11012	RC-03K472JT
R59	P11032	RC-03K512JT
R60	P11013	RC-03K103JT
R61	P11013	RC-03K103JT
R63	P11032	RC-03K512JT
R64	P11069	RC-03K133JT
R66	P11008	RC-03K471JT
R67	P11013	RC-03K103JT
R68	P11024	RC-03K331JT
R69	P11067	RC-03K201JT
R70	P11048	RC-03K121JT
R71	P11024	RC-03K331JT
R72	P11067	RC-03K201JT
R73	P11000	RC-03K000JT
R74	P11013	RC-03K103JT
R75	P11051	RC-03K152JT
R76	P11067	RC-03K201JT
R77	P11013	RC-03K103JT
R78	P11024	RC-03K331JT
R79	P11067	RC-03K201JT
R80	P11013	RC-03K103JT
R82	P11147	RC-03K751JT
R83	P11067	RC-03K201JT
R84	P11013	RC-03K103JT
R86	P11024	RC-03K331JT
R88	P11024	RC-03K331JT
R89	P11167	RC-03K910JT
R90	P11032	RC-03K512JT
R91	P11013	RC-03K103JT
R92	P11031	RC-03K392JT
R93	P11012	RC-03K472JT
R94	P11012	RC-03K472JT
R95	P11012	RC-03K472JT
R96	P11033	RC-03K682JT
R100	P11032	RC-03K512JT
R101	P11031	RC-03K392JT
R102	P11013	RC-03K103JT
R103	P11012	RC-03K472JT

REF No.	PART No.	PART NAME
R104	P11033	RC-03K682JT
R105	P11032	RC-03K512JT
R106	P11013	RC-03K103JT
R107	P11031	RC-03K392JT
R108	P11009	RC-03K102JT
R109	P11032	RC-03K512JT
R110	P11031	RC-03K392JT
R111	P11013	RC-03K103JT
R112	P11009	RC-03K102JT
R113	P11003	RC-03K100JT
R117	P11012	RC-03K472JT
R118	P11012	RC-03K472JT
R119	P11032	RC-03K512JT
R120	P11013	RC-03K103JT
R121	P11031	RC-03K392JT
R122	P11009	RC-03K102JT
R124	P11012	RC-03K472JT
R125	P11012	RC-03K472JT
R126	P11032	RC-03K512JT
R127	P11031	RC-03K392JT
R128	P11013	RC-03K103JT
R129	P11025	RC-03K681JT
R132	P11013	RC-03K103JT
R133	P11019	RC-03K104JT
R134	P11013	RC-03K103JT
R135	P11012	RC-03K472JT
R137	P11013	RC-03K103JT
R139	P11013	RC-03K103JT
R140	P11055	RC-03K822JT
R141	P11013	RC-03K103JT
R142	P11013	RC-03K103JT
R143	P11013	RC-03K103JT
R144	P11012	RC-03K472JT
R145	P11012	RC-03K472JT
R146	P11012	RC-03K472JT
R147	P11012	RC-03K472JT
R148	P11012	RC-03K472JT
R149	P11012	RC-03K472JT
R150	P11012	RC-03K472JT

REF No.	PART No.	PART NAME
R151	P11012	RC-03K472JT
R152	P11012	RC-03K472JT
R154	P11023	RC-03K105JT
R155	P11019	RC-03K104JT
R156	P11019	RC-03K104JT
R157	P11019	RC-03K104JT
R158	P11013	RC-03K103JT
R161	P11019	RC-03K104JT
R162	P11051	RC-03K152JT
R163	P11010	RC-03K202JT
R164	P11056	RC-03K303JT
R165	P11056	RC-03K303JT
R170	P11018	RC-03K473JT
R171	P11018	RC-03K473JT
R174	P11012	RC-03K472JT
R178	P11013	RC-03K103JT
R180	P11039	RC-03K563JT
R181	P11013	RC-03K103JT
R182	P11013	RC-03K103JT
R183	P11018	RC-03K473JT
R184	P11053	RC-03K562JT
R185	P11037	RC-03K273JT
R186	P11117	RC-03K511JT
R187	P11037	RC-03K273JT
R188	P11117	RC-03K511JT
R189	a0476	RY16-1W-10±5%
R190	a0476	RY16-1W-10±5%
R193	a0476	RY16-1W-10±5%
R194	a0476	RY16-1W-10±5%
R197	a0001	RT14-0.25W-2.2±5%
R198	a0001	RT14-0.25W-2.2±5%
R199	a0001	RT14-0.25W-2.2±5%
R201	P11013	RC-03K103JT
R202	P11018	RC-03K473JT
R203	P11013	RC-03K103JT
R204	P11013	RC-03K103JT
R205	P11018	RC-03K473JT
R206	a1102	HZ3B2(1/2W 3V)
R208	P11052	RC-03K302JT

REF No.	PART No.	PART NAME
R209	P11015	RC-03K153JT
R210	P11013	RC-03K103JT
R211	P11013	RC-03K103JT
R212	P11033	RC-03K682JT
R213	P11013	RC-03K103JT
R214	P11013	RC-03K103JT
R215	P11015	RC-03K153JT
R216	P11012	RC-03K472JT
R218	a0705	RT13-0.167W-10±5%
R219	P11013	RC-03K103JT
R220	P11012	RC-03K472JT
R221	P11037	RC-03K273JT
R222	P11012	RC-03K472JT
R223	P11037	RC-03K273JT
R224	P11116	RC-03K470JT
R225	P11051	RC-03K152JT
R226	P11051	RC-03K152JT
R227	P11012	RC-03K472JT
R228	P11012	RC-03K472JT
R250	P11010	RC-03K202JT
R251	P11025	RC-03K681JT
R252	P11010	RC-03K202JT
R253	P11025	RC-03K681JT
R256	P11012	RC-03K472JT
R257	P11032	RC-03K512JT
R258	P11019	RC-03K104JT
R259	P11014	RC-03K123JT
R260	P11009	RC-03K102JT
R261	P11025	RC-03K681JT
R262	P11010	RC-03K202JT
R264	P11006	RC-03K101JT
R265	P11013	RC-03K103JT
R267	P11018	RC-03K473JT
R268	P11013	RC-03K103JT
R269	P11025	RC-03K681JT
R270	a0044	RT14-0.25W-1K±5%
R275	a0495	RY17-2W-100±5%
R276	P11032	RC-03K512JT
R277	P11032	RC-03K512JT

REF No.	PART No.	PART NAME
R278	a0050	RT14-0.25W-2K±5%
R279	a0479	RY16-1W-330±5%
R280	P11012	RC-03K472JT
R281	a0065	RT14-0.25W-8.2K±5%
R282	P11013	RC-03K103JT
R283	P11018	RC-03K473JT
R284	P11019	RC-03K104JT
R285	P11019	RC-03K104JT
R602	P11116	RC-03K470JT
R603	P11003	RC-03K100JT
R608	P11018	RC-03K473JT
R609	P11018	RC-03K473JT
R610	P11018	RC-03K473JT
R611	P11013	RC-03K103JT
R612	P11116	RC-03K470JT
R613	P11142	RC-03K622JT
R614	P11012	RC-03K472JT
R615	P11142	RC-03K622JT
R616	P11012	RC-03K472JT
R620	P11018	RC-03K473JT
R627	P11019	RC-03K104JT
R628	P11019	RC-03K104JT
R629	P11019	RC-03K104JT
R630	P11019	RC-03K104JT
R631	P11019	RC-03K104JT
R684	P11003	RC-03K100JT
R685	P11003	RC-03K100JT
R686	P11198	RC-03K332JT
R687	P11142	RC-03K622JT
R691	P11018	RC-03K473JT
R699	P11116	RC-03K470JT
R700	P11116	RC-03K470JT
R701	P11116	RC-03K470JT
R702	P11116	RC-03K470JT
R703	P11056	RC-03K303JT
R704	P11056	RC-03K303JT
R705	P11019	RC-03K104JT
R706	P11142	RC-03K622JT
R708	P11142	RC-03K622JT

REF No.	PART No.	PART NAME
R713	P11198	RC-03K332JT
R714	P11142	RC-03K622JT
R715	P11002	RC-03K4R7JT
R716	P11002	RC-03K4R7JT
R717	P11002	RC-03K4R7JT
R718	P11002	RC-03K4R7JT
R719	P11036	RC-03K223JT
R720	P11036	RC-03K223JT
R721	P11054	RC-03K752JT
R723	P11018	RC-03K473JT
R724	P11015	RC-03K153JT
R725	P11054	RC-03K752JT
R726	P11018	RC-03K473JT
R727	P11015	RC-03K153JT
R728	P11019	RC-03K104JT
R729	P11035	RC-03K203JT
R730	P11013	RC-03K103JT
R731	P11059	RC-03K334JT
R732	P11013	RC-03K103JT
R733	P11016	RC-03K243JT
R734	P11015	RC-03K153JT
R735	P11013	RC-03K103JT
R736	P11054	RC-03K752JT
R737	P11054	RC-03K752JT
R738	P11015	RC-03K153JT
R739	P11013	RC-03K103JT
R740	P11034	RC-03K183JT
R741	P11018	RC-03K473JT
R742	P11023	RC-03K105JT
R743	P11019	RC-03K104JT
R744	P11018	RC-03K473JT
R745	P11018	RC-03K473JT
R746	P11142	RC-03K622JT
R747	P11019	RC-03K104JT
R748	P11019	RC-03K104JT
R749	P11142	RC-03K622JT
R750	P11146	RC-03K912JT
R751	P11052	RC-03K302JT
R752	P11019	RC-03K104JT

REF No.	PART No.	PART NAME
R753	P11019	RC-03K104JT
R754	P11018	RC-03K473JT
R756	P11012	RC-03K472JT
R757	P11012	RC-03K472JT
R758	P11012	RC-03K472JT
R759	P11012	RC-03K472JT
R760	P11012	RC-03K472JT
R762	P11031	RC-03K475JT
R763	P11012	RC-03K472JT
R764	P11012	RC-03K472JT
R765	P11012	RC-03K472JT
R766	P11012	RC-03K472JT
R768	P11002	RC-03K4R7JT
R769	P11002	RC-03K4R7JT
R770	P11012	RC-03K472JT
R771	P11013	RC-03K103JT
R772	P11013	RC-03K103JT
R773	P11018	RC-03K473JT
R776	a0020	RT14-0.25W-75±5%
R778	P11009	RC-03K102JT
R779	P11003	RC-03K100JT
R780	P11003	RC-03K100JT
R781	P11116	RC-03K470JT
R782	P11116	RC-03K470JT
R785	P11012	RC-03K472JT
R786	P11018	RC-03K473JT
R787	P11003	RC-03K100JT
R788	P11003	RC-03K100JT
R789	P11033	RC-03K682JT
R790	P11198	RC-03K332JT
R791	P11198	RC-03K332JT
R792	P11019	RC-03K104JT
R795	P11019	RC-03K104JT
R796	P11019	RC-03K104JT
R802	P11032	RC-03K512JT
R803	P11009	RC-03K102JT
R804	P11019	RC-03K104JT
R805	P11009	RC-03K102JT
R806	P11116	RC-03K470JT

REF No.	PART No.	PART NAME
R808	P11012	RC-03K472JT
R809	P11005	RC-03K750JT
R810	P11012	RC-03K472JT
R811	P11013	RC-03K103JT
R812	a0483	HCTG4013473
R813	P11012	RC-03K472JT
R814	a0005	RT14-0.25W-10±5%
R815	P11058	RTC03K204JT
CAPACITOR		
C1	P20005	GRM39CH470J50PT
C3	a3508	CD110-4.7uF-M-16V
C4	a3508	CD110-4.7uF-M-16V
C5	P20005	GRM39CH470J50PT
C6	a3635	CD110-47uF-16V-M
C7	a3635	CD110-47uF-16V-M
C9	a3635	CD110-47uF-16V-M
C10	a3635	CD110-47uF-16V-M
C12	P20005	GRM39CH470J50PT
C14	a3508	CD110-4.7uF-M-16V
C15	a3508	CD110-4.7uF-M-16V
C16	P20005	GRM39CH470J50PT
C17	a3635	CD110-47uF-16V-M
C18	a3635	CD110-47uF-16V-M
C20	a3635	CD110-47uF-16V-M
C21	a3635	CD110-47uF-16V-M
C23	a3635	CD110-47uF-16V-M
C24	P20005	GRM39CH470J50PT
C28	P20005	GRM39CH470J50PT
C29	a3635	CD110-47uF-16V-M
C30	a3635	CD110-47uF-16V-M
C31	P20015	GRM39F104Z25PT
C32	a3635	CD110-47uF-16V-M
C33	a3635	CD110-47uF-16V-M
C35	a3635	CD110-47uF-16V-M
C37	a3635	CD110-47uF-16V-M
C38	a3635	CD110-47uF-16V-M
C39	a3635	CD110-47uF-16V-M
C40	a3509	CD110X-10uF-M-16V
C41	a3509	CD110X-10uF-M-16V

REF No.	PART No.	PART NAME
C42	P20005	GRM39CH470J50PT
C43	P20005	GRM39CH470J50PT
C44	a3509	CD110X-22uF-M-16V
C45	a3509	CD110X-22uF-M-16V
C46	a3635	CD110X-47uF-M-16V
C47	P2064	GRM39CH510J50PT
C48	P20052	GRM39CH200J50PT
C49	P2064	GRM39CH510J50PT
C50	P20026	GRM39CH330J50PT
C51	P20015	GRM39F104Z25PT
C52	P20015	GRM39F104Z25PT
C53	P20038	GRM39CH471J50PT
C54	P20038	GRM39CH471J50PT
C55	P20038	GRM39CH471J50PT
C56	a3561	CD110X-470uF-M-10V
C57	a3561	CD110X-470uF-M-10V
C58	a3561	CD110X-470uF-M-10V
C59	P20020	GRM39CH121J50PT
C60	a3635	CD110X-47uF-M-16V
C61	a3561	CD110X-470uF-M-10V
C62	a3561	CD110X-470uF-M-10V
C63	a3561	CD110X-470uF-M-10V
C64	a3561	CD110X-470uF-M-10V
C65	a3561	CD110X-470uF-M-10V
C66	a3561	CD110X-470uF-M-10V
C67	P20012	GRM39B103K50PT
C68	a3561	CD110X-470uF-M-10V
C69	a3561	CD110X-470uF-M-10V
C70	a3561	CD110X-470uF-M-10V
C71	P20033	GRM39CH201J50PT
C74	P20015	GRM39F104Z25PT
C75	P20020	GRM39CH121J50PT
C78	a3509	CD110X-10uF-M-16V
C79	P20063	GRM39B302K50PT
C80	P20029	GRM39CH331J50PT
C81	a3509	CD110X-10uF-M-16V
C82	a3635	CD110X-47uF-M-16V
C83	a3509	CD110X-10uF-M-16V
C84	P20063	GRM39B302K50PT

REF No.	PART No.	PART NAME
C85	P20029	GRM39CH331J50PT
C86	a3509	CD110X-10uF-M-16V
C87	P20015	GRM39F104Z25PT
C88	a3635	CD110X-47uF-M-16V
C93	P20063	GRM39B302J50PT
C94	P20029	GRM39CH331J50PT
C95	a3504	CD110X-0.47uF-M-16V
C96	a3635	CD110X-47uF-M-16V
C98	P20063	GRM39B302J50PT
C99	P20029	GRM39CH331J50PT
C100	a3504	CD110X-0.47uF-M-16V
C101	P20015	GRM39F104Z25PT
C102	a3635	CD110X-47uF-M-16V
C104	P20063	GRM39B302J50PT
C105	P20029	GRM39CH331J50PT
C106	a3504	CD110X-0.47uF-M-16V
C107	a3635	CD110X-47uF-M-16V
C108	a3701	CD11CX-10uF-M-50V
C109	P20035	GRM39F105Z10PT
C110	P20083	GRM39B823K16PT
C111	a3509	CD110X-10uF-M-16V
C112	P20015	GRM39F104Z25PT
C113	a3635	CD110X-47uF-M-16V
C114	P10012	GRM39B103K50PT
C115	P20084	GRM39F154Z16PT
C116	P20042	GRM39B222K50PT
C117	P20015	GRM39F104Z25PT
C118	a3514	CD110X-220uF-M-16V
C119	P20084	GRM39F154Z16PT
C120	P20084	GRM39F154Z16PT
C121	P20084	GRM39F154Z16PT
C122	P20042	GRM39B222K50PT
C124	P20012	GRM39B103K50PT
C128	a3701	CD11CX-10uF-M-50V
C129	a3701	CD11CX-10uF-M-50V
C130	a3506	CD110X-2.2uF-M-16V
C131	a3506	CD110X-2.2uF-M-16V
C132	a3506	CD110X-2.2uF-M-16V
C134	P20012	GRM39B103K50PT

REF No.	PART No.	PART NAME
C135	P20035	GRM39F105Z10PT
C136	P20035	GRM39F105Z10PT
C141	a3064	CL11-100n-63V±20%
C142	a3064	CL11-100n-63V±20%
C143	a3519	CD110X-100uF-M-25V
C145	a3509	CD110X-10uF-M-16V
C151	a3522	CD110X-1000uF-M-25V
C152	a3064	CL11-100n-63V±20%
C153	a3064	CL11-100n-63V±20%
C154	a3522	CD110X-1000uF-M-25V
C157	a3522	CD110X-1000uF-M-25V
C158	a3064	CL11-100n-63V±20%
C159	a3701	CD11CX-10uF-M-50V
C160	P20004	GRM39CH300J50PT
C161	P20004	GRM39CH300J50PT
C162	a3609	CD110X-100uF-M-16V
C163	P20015	GRM39F104Z25PT
C164	a3639	CD11CX-100uF-M-10V
C165	a3637	CD11CX-47uF-M-10V
C166	P20015	GRM39F104Z25PT
C167	a3639	CD11CX-100uF-M-10V
C168	P20015	GRM39F104Z25PT
C169	P20006	GRM39CH101J50PT
C170	P20009	GRM39B102K50PT
C171	a3639	CD11CX-100uF-M-10V
C172	a3639	CD11CX-100uF-M-10V
C173	P20015	GRM39F104Z25PT
C174	a3609	CD110X-100uF-M-16V
C175	a3509	CD110X-10uF-M-16V
C177	a3509	CD110X-10uF-M-16V
C178	a3509	CD110X-10uF-M-16V
C179	a3609	CD110X-100uF-M-16V
C180	P20015	GRM39F104Z25PT
C181	P20015	GRM39F104Z25PT
C182	P20015	GRM39F104Z25PT
C183	a3509	CD110X-10uF-M-16V
C184	P20046	GRM39B561K50PT
C187	P20047	GRM39B392K50PT
C188	P20046	GRM39B561K50PT

REF No.	PART No.	PART NAME
C189	P20015	GRM39F104Z25PT
C190	P20015	GRM39F104Z25PT
C191	P20055	GRM39B562K50PT
C192	a3509	CD110X-10uF-M-16V
C193	a3635	CD110X-47uF-M-16V
C194	P20004	GRM39CH300J50PT
C195	a3635	CD110X-47uF-M-16V
C196	P20004	GRM39CH300J50PT
C197	a3509	CD110X-10uF-M-16V
C198	a3509	CD110X-10uF-M-16V
C199	P20015	GRM39F104Z25PT
C200	a3635	CD110X-47uF-M-16V
C213	a3635	CD110X-47uF-M-16V
C214	a3609	CD110X-100uF-M-16V
C215	P20009	GRM39B102K50PT
C216	a3635	CD110X-47uF-M-16V
C217	P20038	GRM39CH471J50PT
C220	P20020	GRM39CH121J50PT
C221	P20020	GRM39CH121J50PT
C222	a3609	CD110X-100uF-M-16V
C223	a3519	CD110X-100uF-M-25V
C224	a3525	CD110X-4700uF-M-25V
C225	a3635	CD110X-47uF-M-16V
C226	a3635	CD110X-47uF-M-16V
C227	a3635	CD110X-47uF-M-16V
C228	a3525	CD110X-4700uF-M-25V
C229	a3525	CD110X-4700uF-M-25V
C230	a3704	CD110X-47uF-M-25V
C231	a3564	CD110X-470uF-M-35V
C233	a3704	CD110X-47uF-M-25V
C234	a3609	CD110X-100uF-M-16V
C235	a3561	CD110X-470uF-M-10V
C238	P20015	GRM39F104Z25PT
C240	a3637	CD11CX-47uF-M-10V
C601	a3639	CD11CX-100uF-M-10V
C602	a3639	CD11CX-100uF-M-10V
C603	P20015	GRM39F104Z25PT
C604	a3635	CD110X-47uF-M-16V
C605	P20033	GRM39CH201J50PT

REF No.	PART No.	PART NAME
C606	a3635	CD110X-47uF-M-16V
C607	P20055	GRM39B562K50PT
C613	P20015	GRM39F104Z25PT
C615	a3609	CD110X-100uF-M-16V
C616	P20015	GRM39F104Z25PT
C617	P20015	GRM39F104Z25PT
C618	P20015	GRM39F104Z25PT
C620	P20015	GRM39F104Z25PT
C621	P20012	GRM39F103Z25PT
C625	P20015	GRM39F104Z25PT
C627	P20015	GRM39F104Z25PT
C632	P20020	GRM39CH121J50PT
C633	P20020	GRM39CH121J50PT
C677	a3635	CD110X-47uF-M-16V
C678	a3635	CD110X-47uF-M-16V
C683	P20012	GRM39B103K50PT
C684	a3509	CD110X-10uF-M-16V
C685	a3509	CD110X-10uF-M-16V
C686	a3509	CD110X-10uF-M-16V
C687	P20015	GRM39F104Z25PT
C688	P20015	GRM39F104Z25PT
C689	P20040	GRM39B681K50PT
C690	P20015	GRM39F104Z25PT
C691	P20015	GRM39F104Z25PT
C692	P20040	GRM39B681K50PT
C693	P20015	GRM39F104Z25PT
C694	P20013	GRM39B223K50PT
C695	P20013	GRM39B223K50PT
C696	P20015	GRM39F104Z25PT
C697	P20015	GRM39F104Z25PT
C698	P20014	GRM39B473K50PT
C699	P20014	GRM39B473K50PT
C700	P20015	GRM39F104Z25PT
C701	P20044	GRM39F224Z16PT
C702	P20044	GRM39F224Z16PT
C703	a3508	CD110-4.7uF-M-16V
C704	a3508	CD110-4.7uF-M-16V
C705	P20044	GRM39F224Z16PT
C706	P20044	GRM39F224Z16PT

REF No.	PART No.	PART NAME
C707	a3514	CD110X-220uF-M-16V
C708	P20015	GRM39F104Z25PT
C709	P20015	GRM39F104Z25PT
C710	a3509	CD110X-10uF-M-16V
C711	a3509	CD110X-10uF-M-16V
C712	a3509	CD110X-10uF-M-16V
C713	a3509	CD110X-10uF-M-16V
C714	P20074	GRM39B684K50PT
C715	P20056	GRM38B683K50PT
C716	P20055	GRM39B562K50PT
C717	P20040	GRM39B681K50PT
C718	P20043	GRM39B332K50PT
C719	P20043	GRM39B332K50PT
C720	P20012	GRM39B103K50PT
C721	P20013	GRM39B223K50PT
C722	P20013	GRM39B223K50PT
C723	P20012	GRM39B103K50PT
C724	P20040	GRM39B681K50PT
C725	P20043	GRM39B332K50PT
C726	a3609	CD110X-100uF-M-16V
C727	a3609	CD110X-100uF-M-16V
C728	P20015	GRM39F104Z25PT
C729	P20015	GRM39F104Z25PT
C730	P20004	GRM39CH300J50PT
C731	P20004	GRM39CH300J50PT
C732	a3510	CD110X-22uF-M-16V
C733	P20059	GRM39B472K50PT
C736	a3504	CD110X-0.47uF-M-16V
C737	a3504	CD110X-0.47uF-M-16V
C738	a3504	CD110X-0.47uF-M-16V
C741	a3510	CD110X-22uF-M-16V
C742	a3635	CD110X-47uF-M-16V
C743	P20015	GRM39F104Z25PT
C744	P20015	GRM39F104Z25PT
C746	a3564	CD110X-470uF-M-35V
C749	P20015	GRM39F104Z25PT
C750	a3635	CD110X-47uF-M-16V
C752	a3635	CD110X-47uF-M-16V
C753	a3635	CD110X-47uF-M-16V

REF No.	PART No.	PART NAME
C754	P20012	GRM39B103K50PT
C755	a3701	CD11CX-10uF-M-50V
C756	a3701	CD11CX-10uF-M-50V
C757	a3506	CD110X-2.2uF-M-16V
C758	a3506	CD110X-2.2uF-M-16V
C759	a3506	CD110X-2.2uF-M-16V
C760	a3635	CD110X-47uF-M-16V
C761	a3508	CD110-4.7uF-M-16V
C762	P20005	GRM39CH470J50PT
C763	a3508	CD110-4.7uF-M-16V
C766	P20015	GRM39F104Z25PT
C767	P20015	GRM39F104Z25PT
C768	a3509	CD110X-10uF-M-16V
C769	a3509	CD110X-10uF-M-16V
C770	a3509	CD110X-10uF-M-16V
C771	a3509	CD110X-10uF-M-16V
C772	a3509	CD110X-10uF-M-16V
C773	a3509	CD110X-10uF-M-16V
C774	a3509	CD110X-10uF-M-16V
C775	a3635	CD110X-47uF-M-16V
C776	P20015	GRM39F104Z25PT
C777	P20015	GRM39F104Z25PT
C778	P20015	GRM39F104Z25PT
C783	P20012	GRM39B103K50PT
C784	a3514	CD110X-220uF-M-16V
INDUCTOR		
L1	P6817	BSZ2012-600T
L2	P6817	BSZ2012-600T
L3	P6817	BSZ2012-600T
L4	P6817	BSZ2012-600T
L5	P6659	BGH2012B601
L6	P6659	BGH2012B601
L7	P6659	BGH2012B601
L8	P6659	BGH2012B601
L9	P6659	BGH2012B601
L14	P6817	BSZ2012-600T
L15	P6817	BSZ2012-600T
L18	P6659	BGH2012B601
L19	P6659	BGH2012B601



REF No.	PART No.	PART NAME
L20	P6659	BGH2012B601
L21	P6659	BGH2012B601
L22	P6659	BGH2012B601
L23	P6659	BGH2012B601
L24	P6659	BGH2012B601
L25	a6600	5220L1(1uH)
L26	a6600	5220L1(1uH)
L27	P6659	BGH2012B601
L28	P6659	BGH2012B601
L29	P6659	BGH2012B601
L39	P6659	BGH2012B601
L40	P6817	BSZ2012-600T
L41	P6659	BGH2012B601
L43	P6659	BGH2012B601
L44	P6659	BGH2012B601
L47	P6659	BGH2012B601
L48	P6659	BGH2012B601
L49	P6659	BGH2012B601
TRANSISTOR		
VD1	P1200	ISS355
VD2	P1200	ISS355
VD3	P1200	ISS355
VD4	a1111	2CW-9.1V
VD6	P1200	ISS355
VD7	P1200	ISS355
VD8	P1200	ISS355
VD9	a5001	IN4001
VD10	P1200	ISS355
VD12	a5001	IN4001
VD13	a5001	IN4001
VD14	a1125	2CW-25V/0.5W
VD15	a4532	KBU602
VD16	P1200	ISS355
VD17	P1200	ISS355
VD18	P1200	ISS355
VD19	P1200	ISS355
VD32	a1111	2CW-9.1V
VD33	a1114	HZ12A1
VD34	P1200	ISS355

REF No.	PART No.	PART NAME
VD37	P1200	ISS355
VD38	P1200	ISS355
VD40	a5001	IN4001
V5	P5700	2SB709
V6	P5700	2SB709
V7	P5700	2SB709
V8	P5700	2SB709
V9	P5700	2SB709
V10	P5700	2SB709
V11	P5700	2SB709
V12	P5700	2SB709
V13	P5073a	2SD601AR
V14	P5073a	2SD601AR
V19	P5700	2SB709
V20	P5073a	2SD601AR
V23	P5700	2SB709
V25	P5700	2SB709
V26	P5073a	2SD601AR
V27	P5073a	2SD601AR
V28	P5073a	2SD601AR
V29	P5073a	2SD601AR
V30	P5700	2SB709
V31	P5073a	2SD601AR
V32	P5700	2SB709
V33	P5073a	2SD601AR
V34	P5073a	2SD601AR
V39	P5073a	2SD601AR
V40	P5073a	2SD601AR
V41	P5073a	2SD601AR
V42	P5073a	2SD601AR
V43	P5700	2SB709
V44	a5022	2N5551
V45	a5115	2SB1662P/QJH
V49	P5073a	2SD601AR
V50	P5073a	2SD601AR
V51	P5073a	2SD601AR
V53	a5014	C8050C
IC		
D1	P4516	74HCU04

REF No.	PART No.	PART NAME
D2	a4713	W78E58
D3	P4595	BU4053BCF
D4	a4336	XR-1091
D5	a4711	TLC542
D6	a4639	BL24C01
N1	P4530	NJM4558M
N2	P4633	BU4052BCF
N3	P4530	NJM4558M
N4	P4530	NJM4558M
N5	P4530	NJM4558M
N6	P4530	NJM4558M
N7	P4530	NJM4558M
N8	a4411	TDA7265
N9	P4530	NJM4558M
N10	a4709	PT2257
N11	a4503	PT2399
N12	P4530	NJM4558M
N14	P4530	NJM4558M
N16	a4571	CW7805CS
N17	a4571	CW7805CS
N18	a4636	CW7905CS
N19	a4710	PQ12RD11
N20	a4571	CW7805CS
N24	P4633	BU4052BCF
N25	P4633	BU4052BCF
N30	P90107	PT2322-S
N31	a4722	TA8256BH
N32	P90108	NJW1104
OTHER		
S1	a6376	CRYSTAL OSCILLATOR 12MHz
S2	a6354	CRYSTAL OSCILLATOR 4MHz
RP2	a0511	WH06-2-22K
XP1	a6539	B-12B-XH SOCKET
XP2	a6954	FAASD-1562 SOCKET
XP3	a6613	FABSD-2552 SOCKET
XP5	a6556	FABSE-1252
XP10	a6537	B-10B-XH
XP13	a6613	FABSD-2552 SOCKET
XP14	a7029	FAN 2P SOCKET

REF No.	PART No.	PART NAME
XS1	a6944	CKX-063 JACK
XS2	a6762	CS-01 JACK
XS4	a6857	CKX03-GBR