

# SERVICE MANUAL

AUTOMATIC DIRECT DRIVE TURNTABLE

## SANSUI P-D21/D11 (Silver & Black Model)



### CAUTION

1. Parts identified by the  symbol on the schematic diagram and the parts list are critical for safety. Use only replacement parts that have critical characteristics recommended by the manufacturer.
2. Make leakage-current or resistance measurements to determine that exposed parts are acceptably insulated from the supply circuit before returning the appliance to the customer.



SANSUI ELECTRIC CO., LTD.

### •SPECIFICATIONS

#### < P-D21 >

Type.....	Direct-drive turntable
Rated speeds.....	33-1/3, 45 rpm
Platter.....	Aluminum alloy diecast, 304 mm diameter, 0.65 kg (1.43 lbs.) weight
Motor .....	Coreless and Brushless DC/FG Servo
Wow/flutter .....	0.038% (WRMS)
Signal-to-noise ratio .....	Better than 72 dB (DIN-B) Better than 60 dB (IEC-B)
Tonearm .....	Statically-balanced type
Effective tonearm length ..	220 mm (8-11/16")
Power voltage .....	110 ~ 120/220 ~ 240V (50/60 Hz)
	For U.S.A. and Canada 120 V (60 Hz)
Power consumption .....	11 W
Dimensions .....	430 mm (16-29/32") W 120 mm (4-23/32") H 360 mm (14-3/16") D
Weight.....	4.2 kg (9.3 lbs.) net 5.0 kg (11.0 lbs.) packed

#### Specifications of the cartridge (applicable only to the units with cartridge)

##### Model SV-P313

Type.....	Dual Magnet type
Output voltage.....	2.5 mV (1,000 Hz, 35.4 mm/sec)
Correct load impedance..	47 kohms
Frequency response.....	20 ~ 20,000 Hz
Stylus.....	0.6 mil diamond stylus (SN-P313 replacement stylus)

#### < P-D11 >

Type.....	Direct-drive turntable
Rated speeds.....	33-1/3, 45 rpm
Platter.....	Aluminum alloy diecast, 304 mm (12") diameter, 0.65 kg (1.43 lbs.) weight
Motor .....	Coreless and Brushless DC/FG Servo
Wow/flutter .....	0.038% (WRMS)
Signal-to-noise ratio .....	Better than 72 dB (DIN-B) Better than 60 dB (IEC-B)
Tonearm .....	Statically-balanced type
Effective tonearm length ..	220 mm (8-11/16")
Power voltage .....	110 ~ 120/220 ~ 240V (50/60 Hz)
	For U.S.A. and Canada 120 V (60 Hz)
Power consumption .....	10 W
Dimensions .....	430 mm (16-29/32") W 120 mm (4-23/32") H 360 mm (14-3/16") D
Weight.....	4.1 kg (9.0 lbs.) net 4.9 kg (10.8 lbs.) packed

#### Specifications of the cartridge (applicable only to the units with cartridge)

##### Model SV-P313

Type.....	Dual Magnet type
Output voltage.....	2.5 mV (1,000 Hz, 35.4 mm/sec)
Correct load impedance..	47 kohms
Frequency response.....	20 ~ 20,000 Hz
Stylus.....	0.6 mil diamond stylus (SN-P313 replacement stylus)

\* Design and specifications subject to change without notice for improvements.

# 1. PARTS LOCATION & PARTS LIST

•Note: The circuit boards are not supplied as the assembled. However, individual parts on the circuit board are provided by orders.

•Since some of capacitors and resistors are omitted from parts lists in this service manual, refer to the Common Parts List for capacitors & resistors, which was issued on February 1983.

## 1-1. S-0121 Motor Control Circuit Board <P-D11/D21>

Component Side

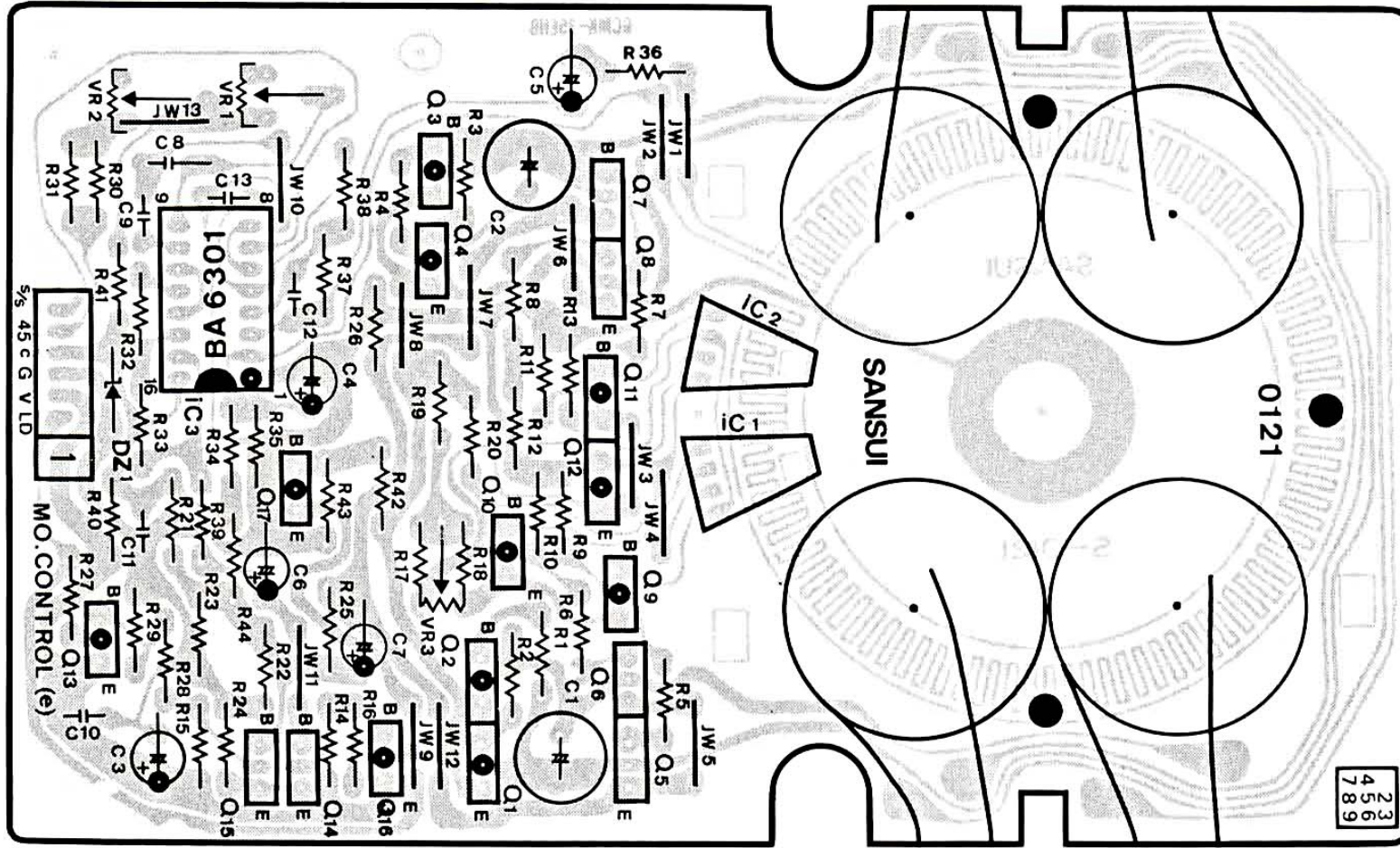

### •Abbreviations List

C.R.	: Carbon Resistor
S.R.	: Solid Resistor
Ce.R.	: Cement Resistor
M.R.	: Metal Film Resistor
F.R.	: Fusing Resistor
N.I.R.	: Non-Inflammable Resistor
A.R.	: Array Resistor
C.C.	: Ceramic Capacitor
C.T.	: Ceramic Capacitor, Temperature Compensation
E.C.	: Electrolytic Capacitor
E.L.	: Low Leak Electrolytic Capacitor
E.B.	: Bi-Polar Electrolytic Capacitor
E.B.L.	: Low Leak Bi-Polar Electrolytic Capacitor
Ta.C.	: Tantalum Capacitor
F.C.	: Film Capacitor
M.P.	: Metalized Paper Capacitor
P.C.	: Polystyrene Capacitor
G.C.	: Gimmic Capacitor
A.C.	: Array Capacitor
V.R.	: Variable Resistor
S.V.R.	: Semi Variable Resistor
SW.	: Switch
Chip R.	: Chip Resistor
Chip C.	: Chip Capacitor

### Parts List

Parts No.	Stock No.	Description	Parts No.	Stock No.	Description	Parts No.	Stock No.	Description
•Transistor			eQ13	46367402	2SA733A	•Zener Diode		
eQ1	46359701	2SA952		or 46367001	2SA1115	eDZ1	46113900	05Z12-Y
eQ2	46359701	2SA952		or 46367201	2SA1048	eR41	46639000	240kΩ 1/4W M.R.
eQ3	46359701	2SA952	eQ14	46367502	2SC945A	eC1	08451100	22μF 16V E.B.
eQ4	46359701	2SA952		or 46367101	2SC2603	eC2	08451100	22μF 16V E.B.
eQ5	46359801	2SC2001		or 46367301	2SC2458	eC10	07216600	47000pF 25V C.C.
eQ6	46359801	2SC2001	eQ15	46367502	2SC945A	eC11	07216600	47000pF 25V C.C.
eQ7	46359801	2SC2001		or 46367101	2SC2603	eC12	07211700	1000pF 25V C.C.
eQ8	46359801	2SC2001		or 46367301	2SC2458	eC13	07211700	1000pF 25V C.C.
eQ9	46367401	2SA733A	eQ16	46614001	2SA1283	eVR1	46366600	100kΩ (B) S.V.R., speed selector, 33-1/3 rpm
	or 46367001	2SA1115	eQ17	46367402	2SA733A	eVR2	07241700	200kΩ (B) S.V.R., speed selector, 45 rpm
eQ10	46367401	2SA733A		or 46367001	2SA1115	eVR3	07241000	1kΩ (B) S.V.R., wow & flutter
	or 46367001	2SA1115	•IC					
	or 46367201	2SA1048	eIC1	46354301	HW-301C-Q			
eQ11	46367401	2SA733A		or 46354302	HW-301C-R			
	or 46367001	2SA1115	eIC2	46354301	HW-301C-Q			
	or 46367201	2SA1048		or 46354302	HW-301C-R			
eQ12	46367401	2SA733A	eIC3	46354400	BA6301			
	or 46367001	2SA1115						
	or 46367201	2SA1048						
	or 46367000	2SA1115						

## 1-2. S-0125 Power Supply Circuit Board <P-D11> (XX, UL, CSA)

Component Side

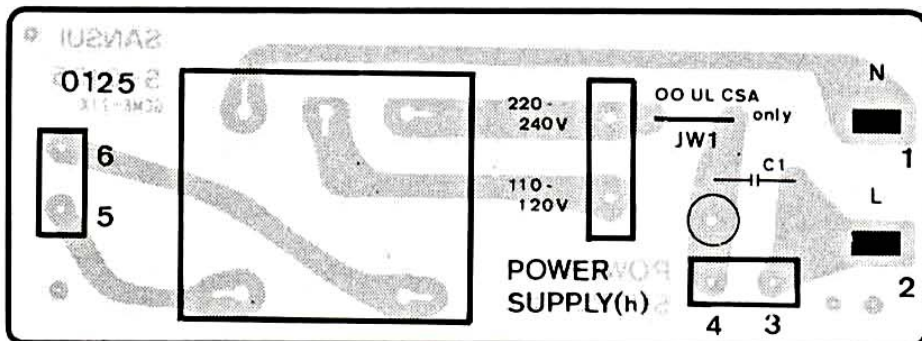

### Parts List

Parts No.	Stock No.	Description
△ hC1	46425800	10000pF 400V C.C.
△ hT1	15007701	Power Transformer (XX)
	15007702	Power Transformer (UL, CSA)

### 1-3. S-0149 Indicator Circuit Board <P-D21>

Component Side

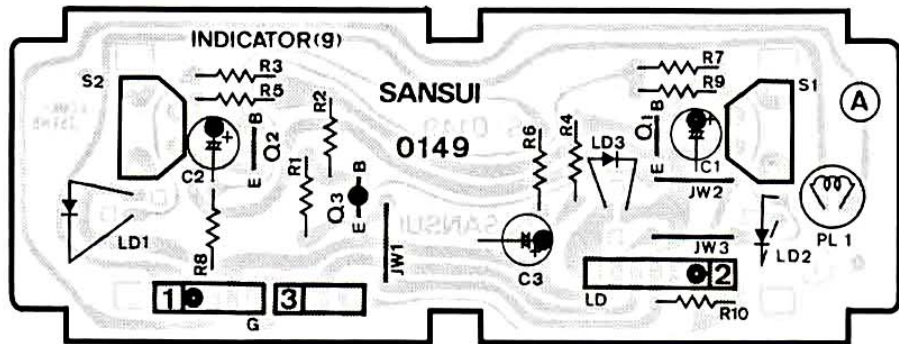

#### Parts List

Parts No.	Stock No.	Description
<b>•Transistor</b>		
gQ1	07299701	2SC2603
	or 03059501	2SC945
	or 07194801	2SC1815
gQ2	07299701	2SC2603
	or 03059501	2SC945
	or 07194801	2SC1815
gQ3	07299601	2SA1115
	or 07197001	2SA733A
	or 07194701	2SA1015
<b>•LED</b>		
gLD1	46095200	TLR123
gLD2	46095200	TLR123
gLD3	07250900	TLG123
gPL1	46438300	Pilot Lamp 12V 0.1A
gSW1	46395900	Push SW. speed selector, 33 1/3 rpm
gSW2	46395900	Push SW. speed selector, 45 rpm

### 1-4. S-0123 Power Supply Circuit Board <P-D11>

Component Side

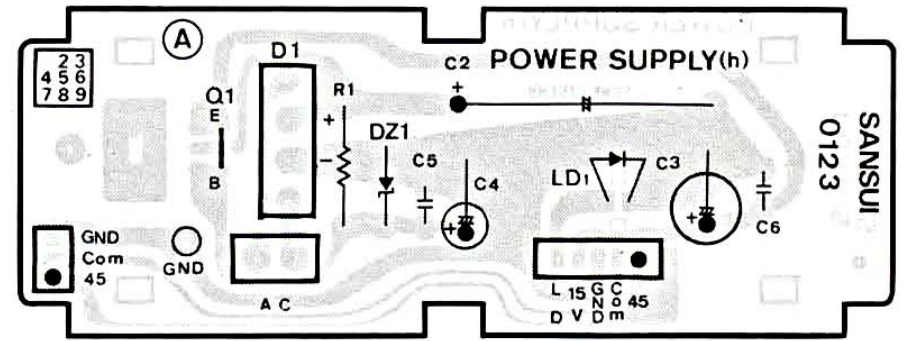

#### Parts List

Parts No.	Stock No.	Description
<b>•LED</b>		
gLD1	07250900	TLG123
<b>•Transistor</b>		
hQ1	03083902	2SD313AL
<b>•Diode</b>		
hD1	03117000	RB-152
hR1	46243700	1.2kΩ 1W N.I.R.
<b>•Zener Diode</b>		
hDZ1	46104500	05Z16-X
hR1	00181300	2.2kΩ 1W N.I.R.
hC2	46368700	470μF 25V
hC5	07213600	22000pF 25V C.C.
hC6	07213600	22000pF 25V C.C.

### 1-5. S-0150 Power Supply Circuit Board <P-D21>

Component Side

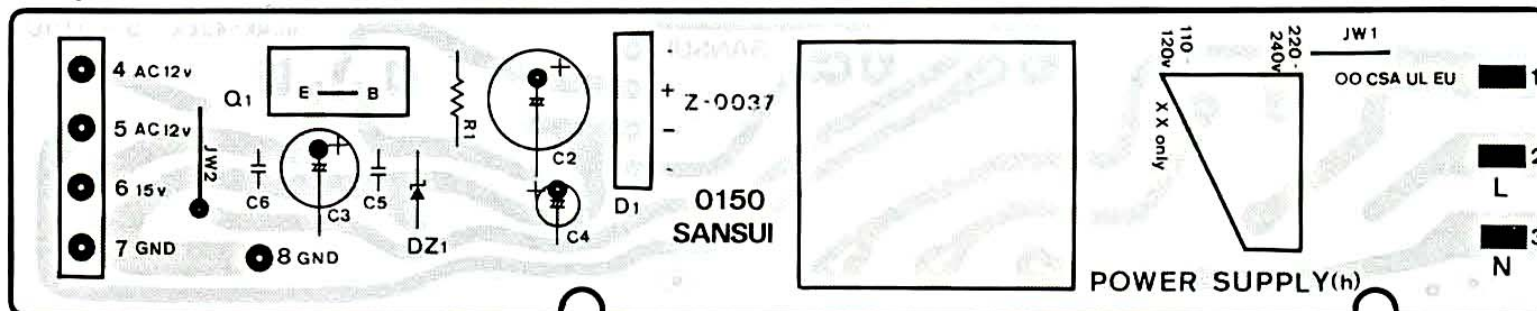

#### Parts List

Parts No.	Stock No.	Description
<b>•Transistor</b>		
hQ1	0308902	2SD313AL
<b>•Diode</b>		
hD1	03117000	RB-152
<b>•Zener Diode</b>		
hDZ1	46104500	05Z16
hR1	00181300	2.2kΩ 1W N.I.R.
hC5	07213600	22000pF 25V C.C.
hC6	07213600	22000pF 25V C.C.
hT1	15008901	Power Transformer (XX)
hT1	15008905	Power Transformer (EU, BS, AS)
hT1	15008902	Power Transformer (UL, CSA)
hF1	07184300	Power Fuse 400mA 250V <EU>

### 1-6. S-0148 Power Supply Circuit Board

Component Side

<P-D11> (EU, BS, AS)

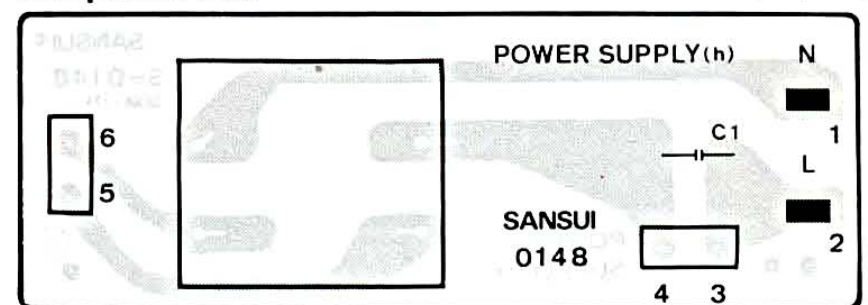

#### Parts List

Parts No.	Stock No.	Description
hC1	46425800	10000pF 400V C.C.
hT1	15007705	Power Transformer (EU,BS,AS)

## 2. OTHER PARTS

### 2-1. Front View <P-D21>



### 2-2. Top View <P-D21>

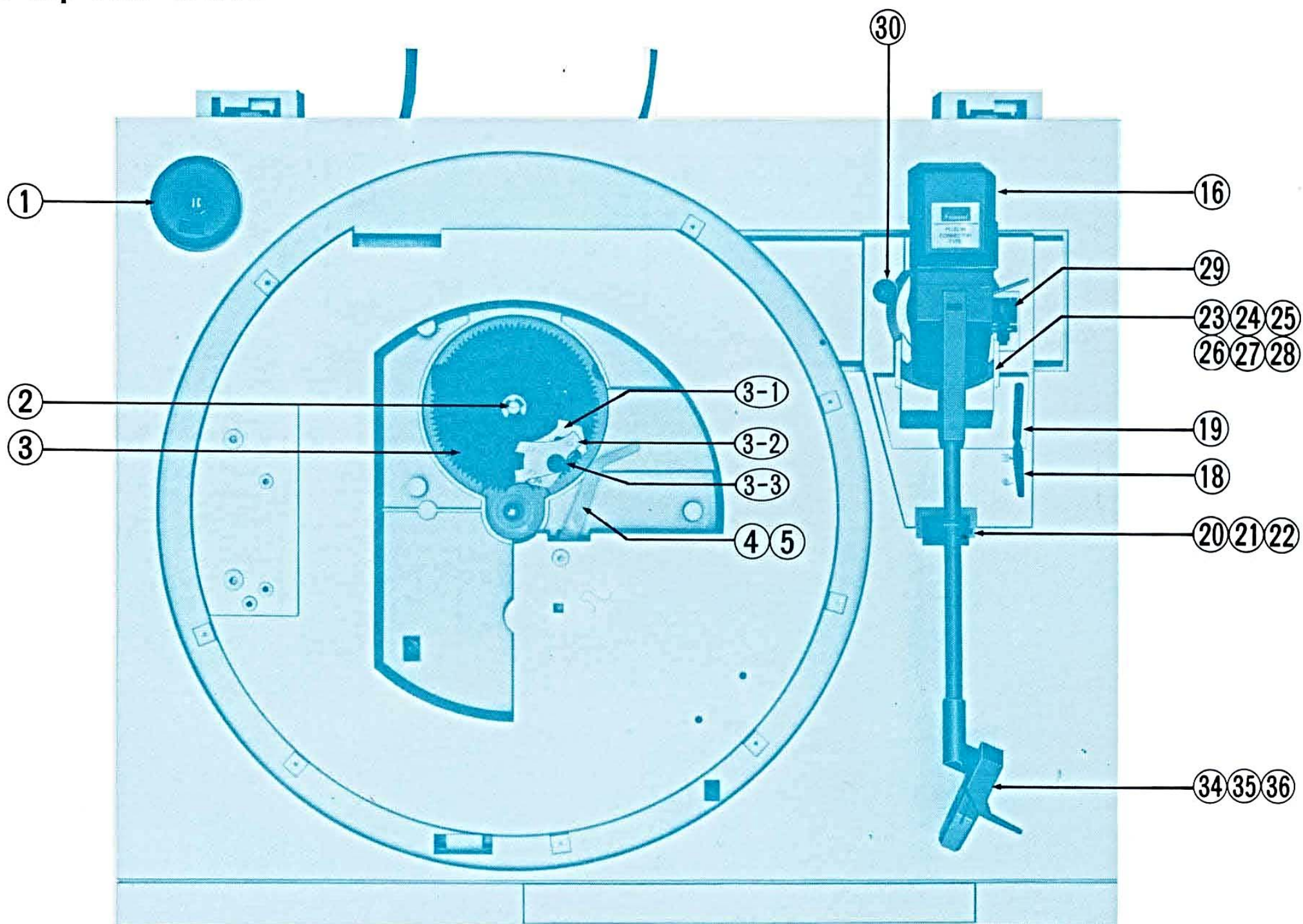

**Parts List < Front View/Top View > < P-D21/P-D11 >**

Parts No.	Stock No.	Description
1	13012300	45 r.p.m. Adaptor
2	00489400	E Ring 5ø, main gear
3	13017200	Main Gear
3-1	_____	Lower Trip
3-2	_____	Upper Trip
3-3	51822900	CS Type Washer, 3ø
4	13136400	Reject Arm
5	13143400	Tension Spring, reject arm
6	46368500	Speed SW. <P-D11 only>
△	46364300	Power SW. <P-D21 only>
7	07910900	Push SW. Knob (Silver)
	07911000	Push SW. Knob (Black)
8	13272800	Indicator Case Cover <P-D11 only>
	13272200	Indicator Case Cover <P-D21 only>
9	13272900	Indicator Plate <P-D11 only>
	13272300	Indicator Plate <P-D21 only>
10	13164300	Indicator Holder <P-D11 only>
	13145810	Indicator Holder <P-D21 only>
11	46395900	Push SW., speed selector <P-D21 only>
12	46494310	Speed SW. Knob, 45 r.p.m. (H) <P-D21 only>
13	47494210	Speed SW. KNob, 33 r.p.m. (L) <P-D21 only>
14	13259300	Cushion, speed SW. <P-D21 only>
15	13142100	Reject Knob (Silver)
	13142200	Reject Knob (Black)
16	13289500	Tone Arm Ass'y <P-D11 only>
	13289600	Tone Arm Ass'y <P-D21 only>
18	13013500	Lifter Knob
19	13138300	Lifter Lever Ass'y
20	13138700	Arm Rest (Black)
21	13138500	Fork, arm rest (Black)
22	13167700	Bind Tapping Screw, 2×5
23	13138200	Lifter Plate
24	13035600	Spring, 5.3ø×10 mm (C)
25	13035700	Spring, 9.3ø×14 mm (E)
26	00466500	P Type Washer 3ø×10
27	13011600	Elevation Chip
28	13038010	B Type Tapping Screw M3×16
29	13272100	IFC Ass'y <P-D21 only>
30	50624800	Cup for auto return adjustment
31	13140800	Turntable Sheet <XX, CSA, EU, BS, AS>
	13140900	Turntable Sheet <UL>
32	13147210	Platter
34	13283300	Cartridge, SV-P313
35	13283400	Stylus, SN-P313
36	13288800	Screw Ass'y
	13142400	Dust Cover Ass'y
	13142600	Auto Hinge, dust cover ass'y

**2-3. Bottom View**

**Parts List < Bottom View > (P-D11/P-D21)**

Parts No.	Stock No.	Description
1	11602500	Micro Switch (P-D21 = Motor SW/P-D11 = POWER SW)
2	13143710	Screw, micro switch
3	13038010	Pan head Tapping Screw M3×16 (Adjusting Screw)
4	69034400	Spring, PU plate
5	13143000	Push Pin
6	13038210	Screw, slide arm
7	00467100	P Type Washer 5ø×10×1.0
8	13051900	Steel Ball 5ø
9	13136700	Reject Lever (3)
10	13038300	Reject lever (1)
11	07254700	Strain Relief
12	13154300	Output Cord <XX, CSA, EU, BS, AS>
	13154400	Output Cord <UL>
13	00489300	E Ring 4ø
14	00467100	P Type Washer 5ø×10×1.0
15	69034300	Spring, slide arm
△	46413200	Power Cord (XX, CSA)
△	07204200	Power Cord (AS)
△	38004300	Power Cord (BS)
△	38004500	Power Cord (EU)
△	38004700	Power Cord (UL)
17	18028700	DD Motor Ass'y, SSD703A with control circuit board, S-0121
△	15008901	Power Transformer <P-D21> (XX)
△	15008905	Power Transformer <P-D21> (EU, BS, AS)
△	15008902	Power Transformer <P-D21> (UL, CSA)
△	15007701	Power Transformer <P-D11> (XX)
△	15007705	Power Transformer <P-D11> (EU, BS, AS)
△	15007702	Power Transformer <P-D11> (UL, CSA)
19	08320700	Brazier head Tapping Screw, 4×12
20	46425800	10000pF 400V C.C. <P-D21 only> (EU, BS, AS)
	13153500	Insulator

**Note:**

The symbols, UL, CSA, SA, BS, UK, EU, AS and XX in the parts list and schematic diagram mean followings respectively.

- UL..... Manufactured for U.S.A market  
(Underwriters Laboratories approved model.)
- CSA ..... Manufactured for Canadian market.
- SA..... Manufactured for South African market.
- BS, UK ..... Manufactured for United Kingdom market.
- EU ..... Manufactured for European market.
- AS..... Manufactured for Australian market.
- XX..... Standard Version.
- NON MARK ..... Common Parts.

<P-D21>

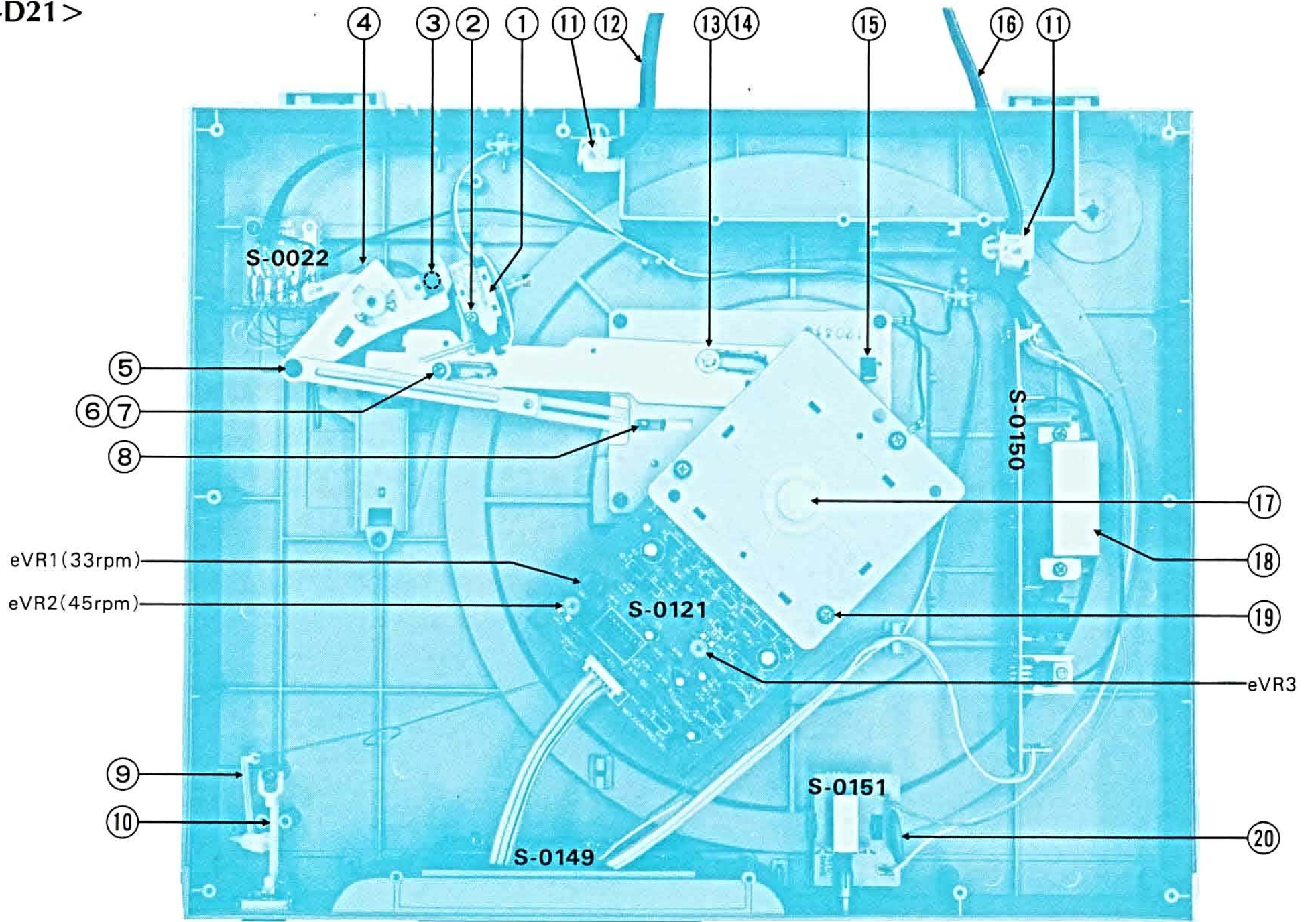

<P-D11>

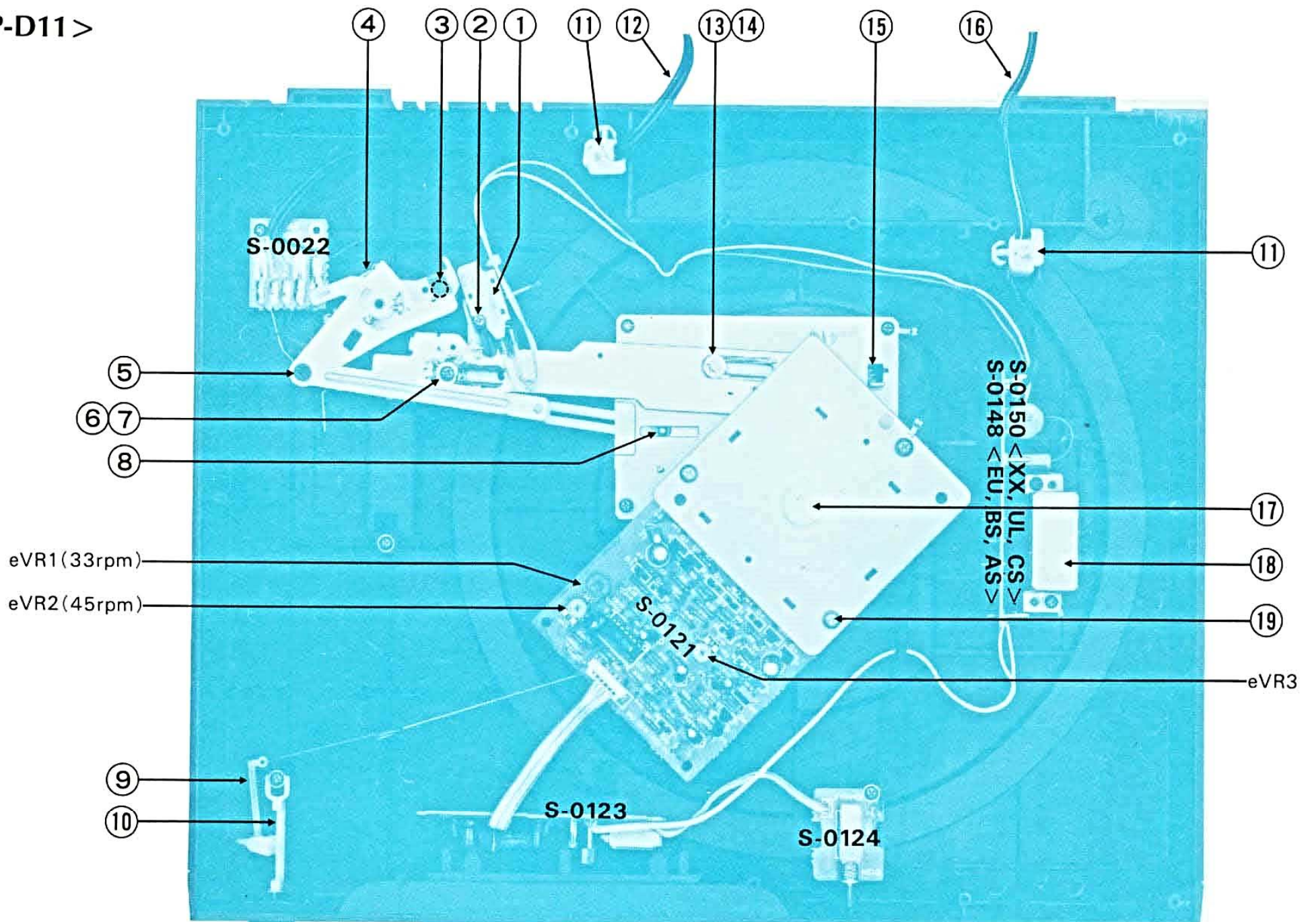

A

B

C

D

# 3. SCHEMATIC DIAGRAM

## 3-1. P-D11

\*Design and specifications subject to change without notice for improvement.  
 \*La présentation et les spécifications sont susceptibles d'être modifiées sans préavis par suites d'améliorations éventuelles.  
 \*Änderungen, die dem technischen Fortschritt dienen, bleiben vorbehalten.

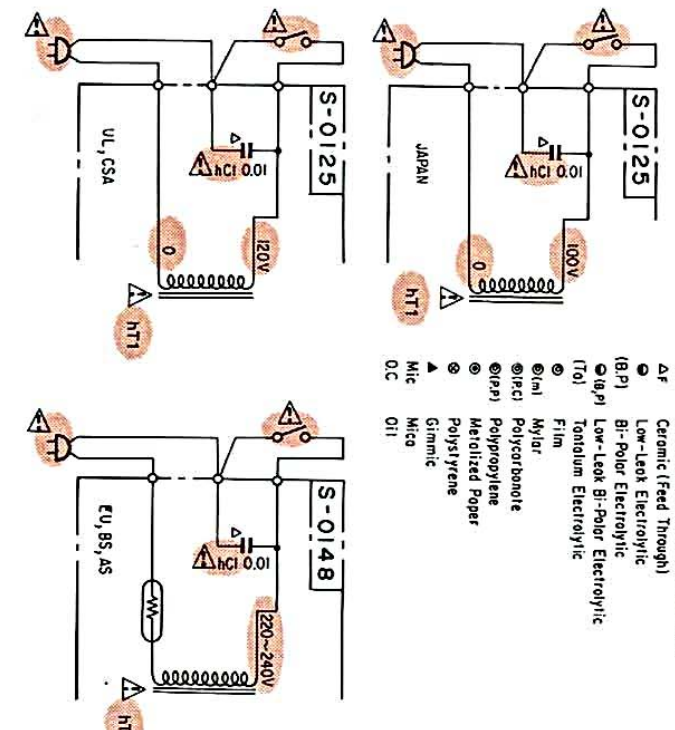
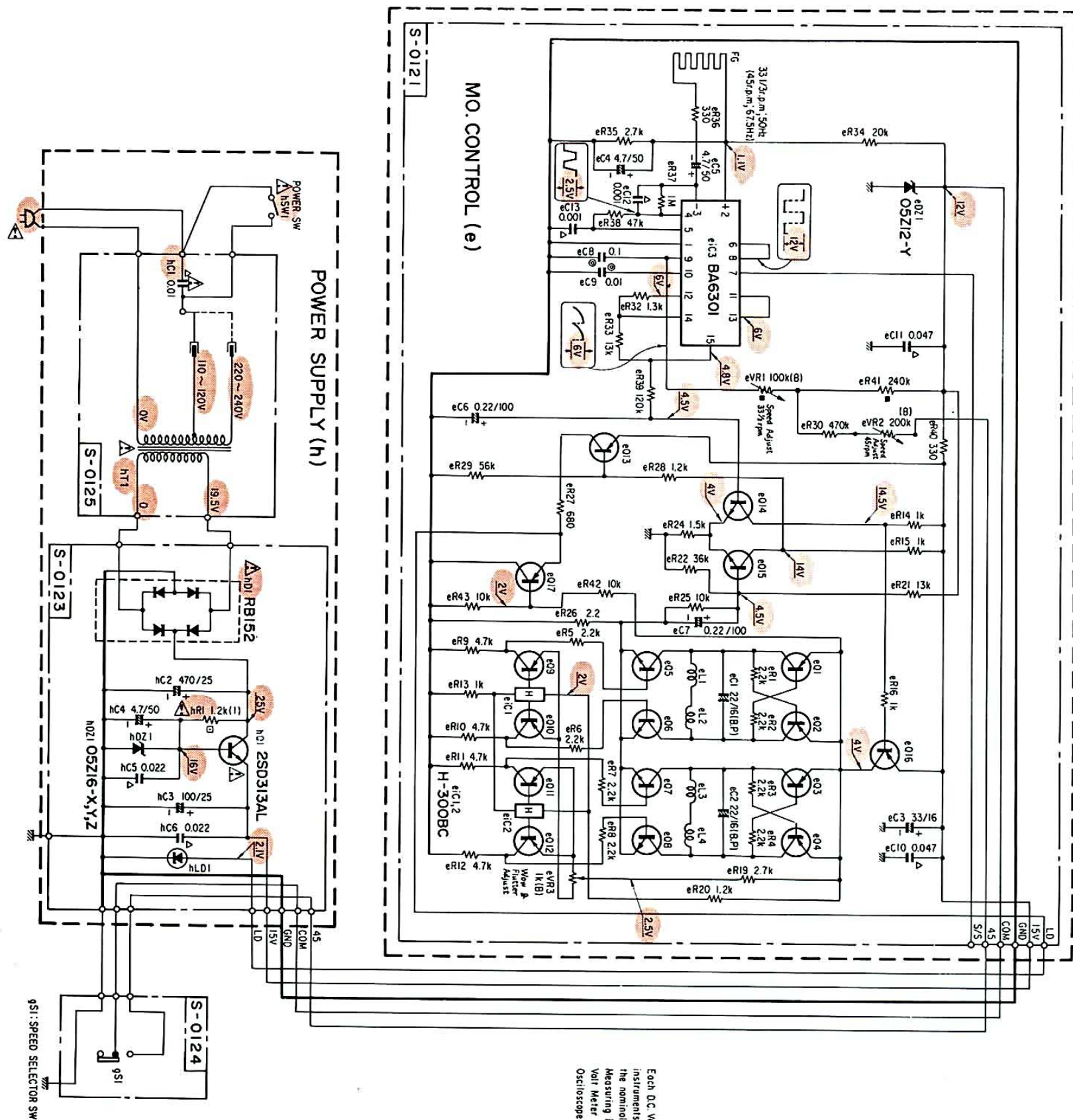

Each D.C. Voltage measured by the instruments described below shows the nominal value in volts of 33/125 μm Measuring Instruments Volt Meter DC 20kΩ/V, AC 1kΩ/V Oscilloscope 5MHz

- e01~4 2SA952 M,L
- e05~8 2SC2001 M,L
- e09~12 2SA733A O,P
- e013 2SA1115 E,F
- e014,15 2SA1048 Y,GR
- e016 2SA1115 F
- e017 2SA1048 GR
- e018 2SC945A P
- e019 2SC2603 F
- e020 2SC2458 GR
- e021 2SB744 O,P
- e022 2SA733A P
- e023 2SA1115 F
- e024 2SA1048 GR

- SYMBOLS**
- ▲ Is Safety Part. Use only replacement parts recommended by the manufacturer.
  - Non-Flammable Resistor
  - Metal Film Resistor
- RESISTORS**  
 Are in ohms, 1/4 watts, ±5% Tolerance Unless Otherwise Noted. K: kΩ, M: MΩ
- CAPACITORS**  
 Are in μF, Unless Otherwise Noted. P: pF
- SYMBOLS**
- Δ Ceramic
  - ΔT Ceramic (Temperature Compensation)
  - ΔF Ceramic (Feed Through)
  - ΔL Low-Leak Electrolytic
  - (B,P) Bi-Polar Electrolytic
  - (L,P) Low-Leak Bi-Polar Electrolytic
  - (Tol) Tantalum Electrolytic
  - (Fil) Film
  - (Myl) Mylar
  - (Pcb) Polycarbonate
  - (Pap) Polypropylene
  - (MPP) Metallized Paper
  - (Pst) Polystyrene
  - (Gim) Glimic
  - (Mic) Mic
  - (DC) DC

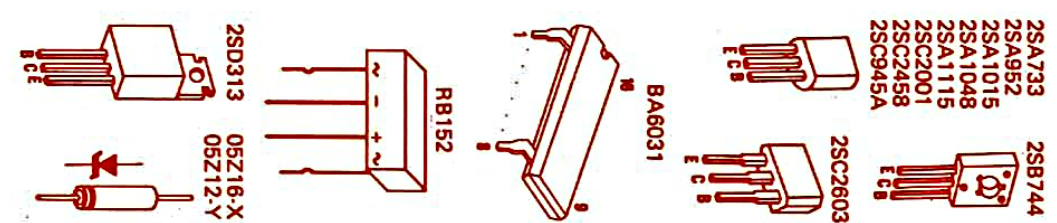

1

2

3

4

5

\*Design and specifications subject to change without notice for improvement.  
 \*La présentation et les spécifications sont susceptibles d'être modifiées sans préavis par suites d'améliorations éventuelles.  
 \*Änderungen, die dem technischen Fortschritt dienen, bleiben vorbehalten.

3-2. P-D21

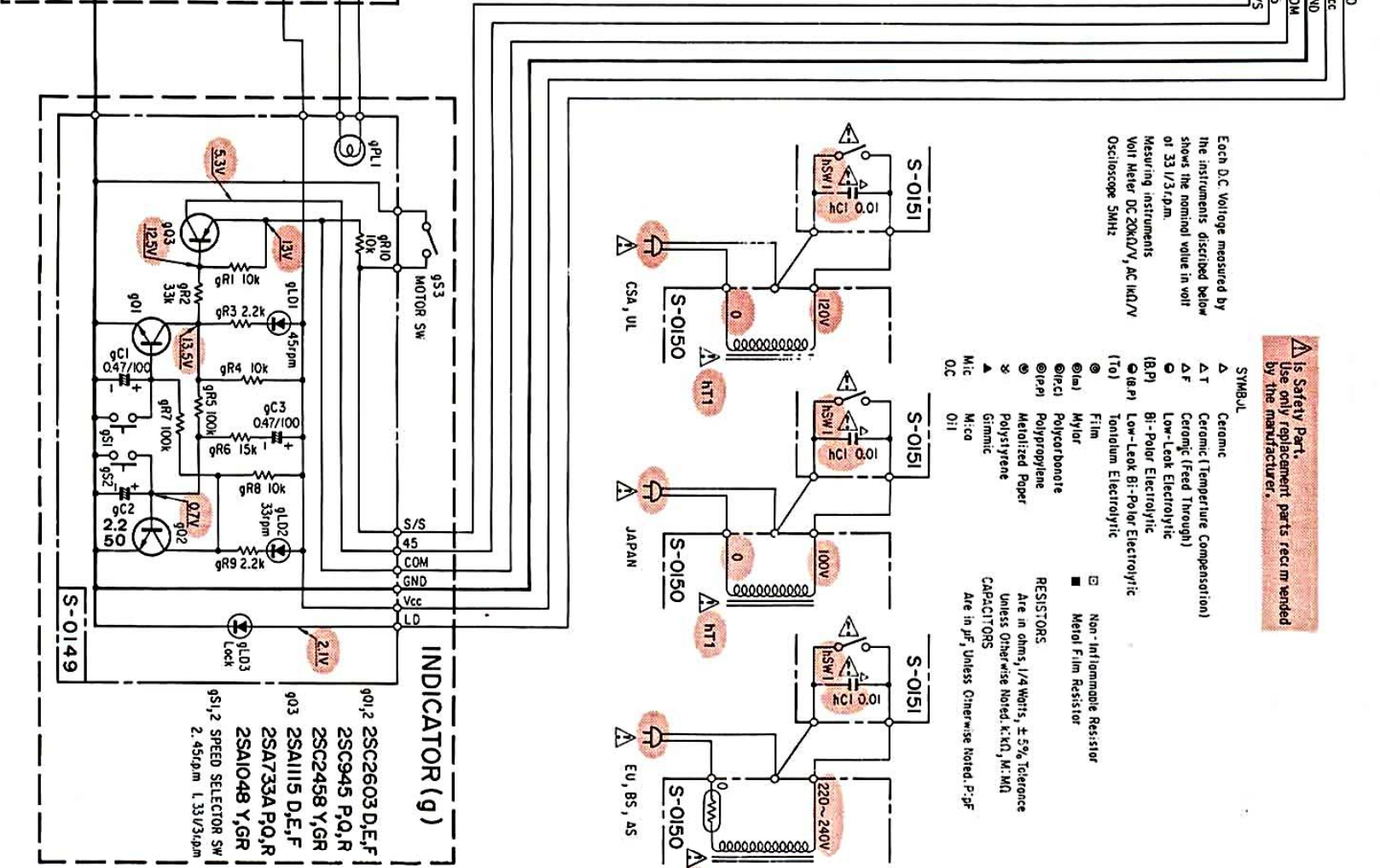
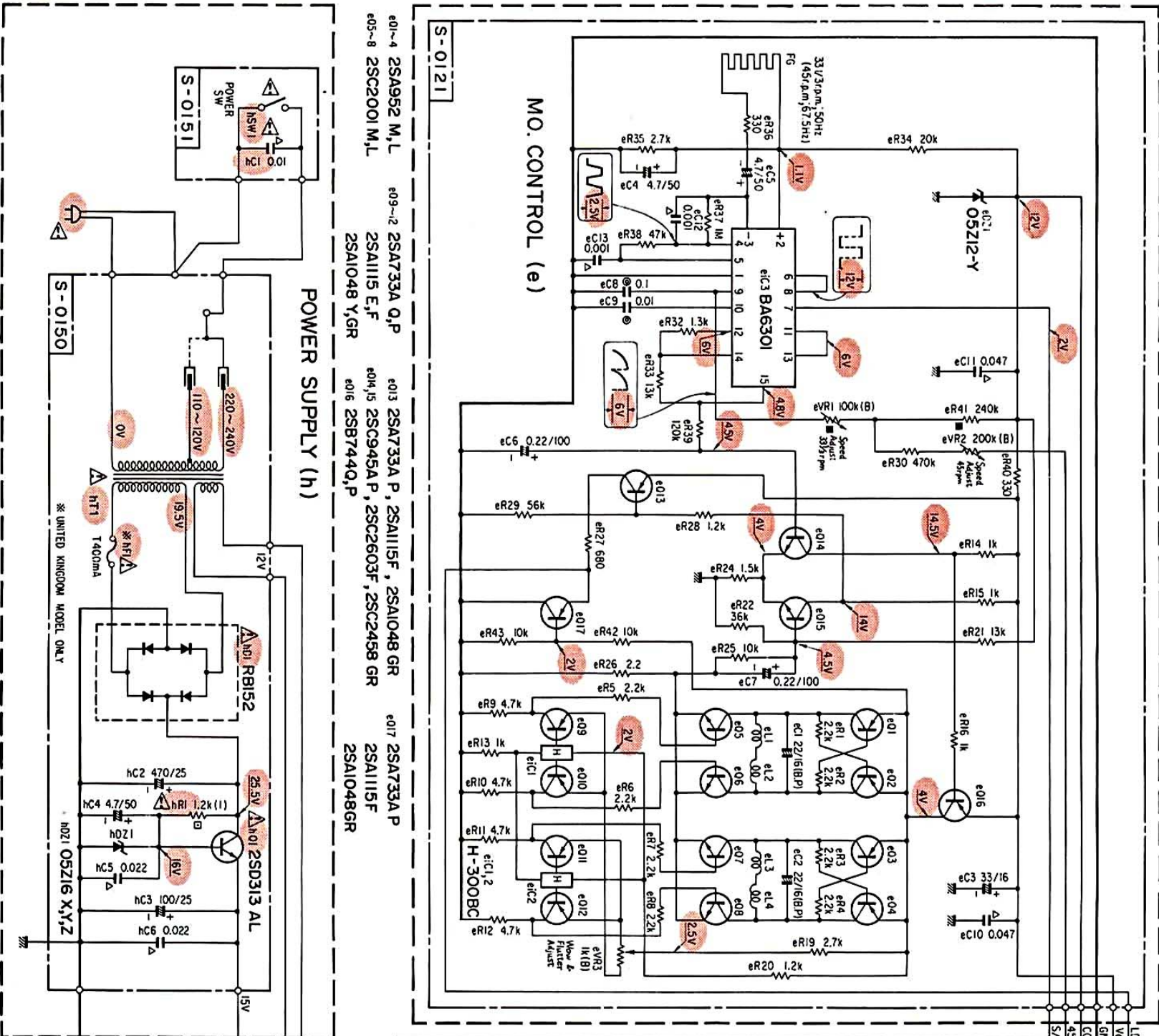

▲ is Safety Part, Use only replacement parts rec'm vended by the manufacturer.

- Each DC Voltage measured by the instruments described below shows the nominal value in volt or 33 1/3 rpm.
- Masuring instruments:  
 Volt Meter DC 2000V, AC 1kV/V  
 Oscilloscope 5MHz
- SYMBOL
- ▲ Ceramic
  - ΔT Ceramic (Temperature Compensation)
  - ΔF Ceramic (Feed Through)
  - Low-Leak Electrolytic
  - (B) Bi-Polar Electrolytic
  - (L) Low-Leak Bi-Polar Electrolytic
  - (T) Tantalum Electrolytic
  - Film
  - Mylar
  - Polypropylene
  - Polystyrene
  - Metallized Paper
  - Gimmic
  - Mica
  - Non-Inflammable Resistor
  - Metal Film Resistor
- RESISTORS  
 Are in ohms, 1/4 Watts, ±5% Tolerance  
 Unless Otherwise Noted, k, M, M: MΩ  
 CAPACITORS  
 Are in pF, Unless Otherwise Noted, F: pF

- e01-4 25A952 M,L
- e03 25A733A Q,P
- e04,5 25C945A P, 25C2603F, 25C2458 GR
- e05-8 25C2001 M,L
- e06 25B7440, P
- e07 25A733A P
- e08 25A1015 F
- e09-12 25A733A Q,P
- e10 25A1048 Y,GR
- e11 25A1048 GR
- e12 25A1048 GR
- e13 25A1048 GR
- e14 25A1048 GR
- e15 25A1048 GR
- e16 25A1048 GR
- e17 25A733A P
- e18 25A1048 GR
- e19 25A1048 GR
- e20 25A1048 GR
- e21 25A1048 GR
- e22 25A1048 GR
- e23 25A1048 GR
- e24 25A1048 GR
- e25 25A1048 GR
- e26 25A1048 GR
- e27 25A1048 GR
- e28 25A1048 GR
- e29 25A1048 GR
- e30 25A1048 GR
- e31 25A1048 GR
- e32 25A1048 GR
- e33 25A1048 GR
- e34 25A1048 GR
- e35 25A1048 GR
- e36 25A1048 GR
- e37 25A1048 GR
- e38 25A1048 GR
- e39 25A1048 GR
- e40 25A1048 GR
- e41 25A1048 GR
- e42 25A1048 GR
- e43 25A1048 GR
- e44 25A1048 GR
- e45 25A1048 GR
- e46 25A1048 GR
- e47 25A1048 GR
- e48 25A1048 GR
- e49 25A1048 GR
- e50 25A1048 GR
- e51 25A1048 GR
- e52 25A1048 GR
- e53 25A1048 GR
- e54 25A1048 GR
- e55 25A1048 GR
- e56 25A1048 GR
- e57 25A1048 GR
- e58 25A1048 GR
- e59 25A1048 GR
- e60 25A1048 GR
- e61 25A1048 GR
- e62 25A1048 GR
- e63 25A1048 GR
- e64 25A1048 GR
- e65 25A1048 GR
- e66 25A1048 GR
- e67 25A1048 GR
- e68 25A1048 GR
- e69 25A1048 GR
- e70 25A1048 GR
- e71 25A1048 GR
- e72 25A1048 GR
- e73 25A1048 GR
- e74 25A1048 GR
- e75 25A1048 GR
- e76 25A1048 GR
- e77 25A1048 GR
- e78 25A1048 GR
- e79 25A1048 GR
- e80 25A1048 GR
- e81 25A1048 GR
- e82 25A1048 GR
- e83 25A1048 GR
- e84 25A1048 GR
- e85 25A1048 GR
- e86 25A1048 GR
- e87 25A1048 GR
- e88 25A1048 GR
- e89 25A1048 GR
- e90 25A1048 GR
- e91 25A1048 GR
- e92 25A1048 GR
- e93 25A1048 GR
- e94 25A1048 GR
- e95 25A1048 GR
- e96 25A1048 GR
- e97 25A1048 GR
- e98 25A1048 GR
- e99 25A1048 GR
- e00 25A1048 GR

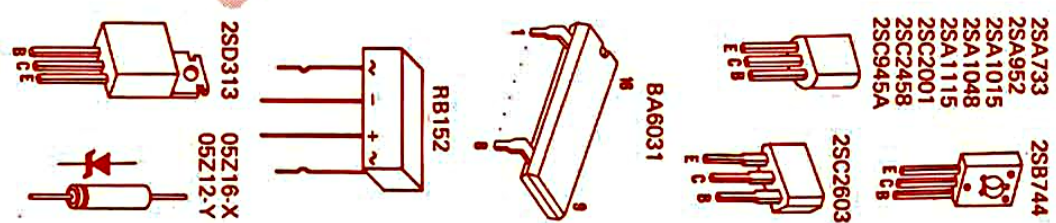



# 4. BLOCK DIAGRAM

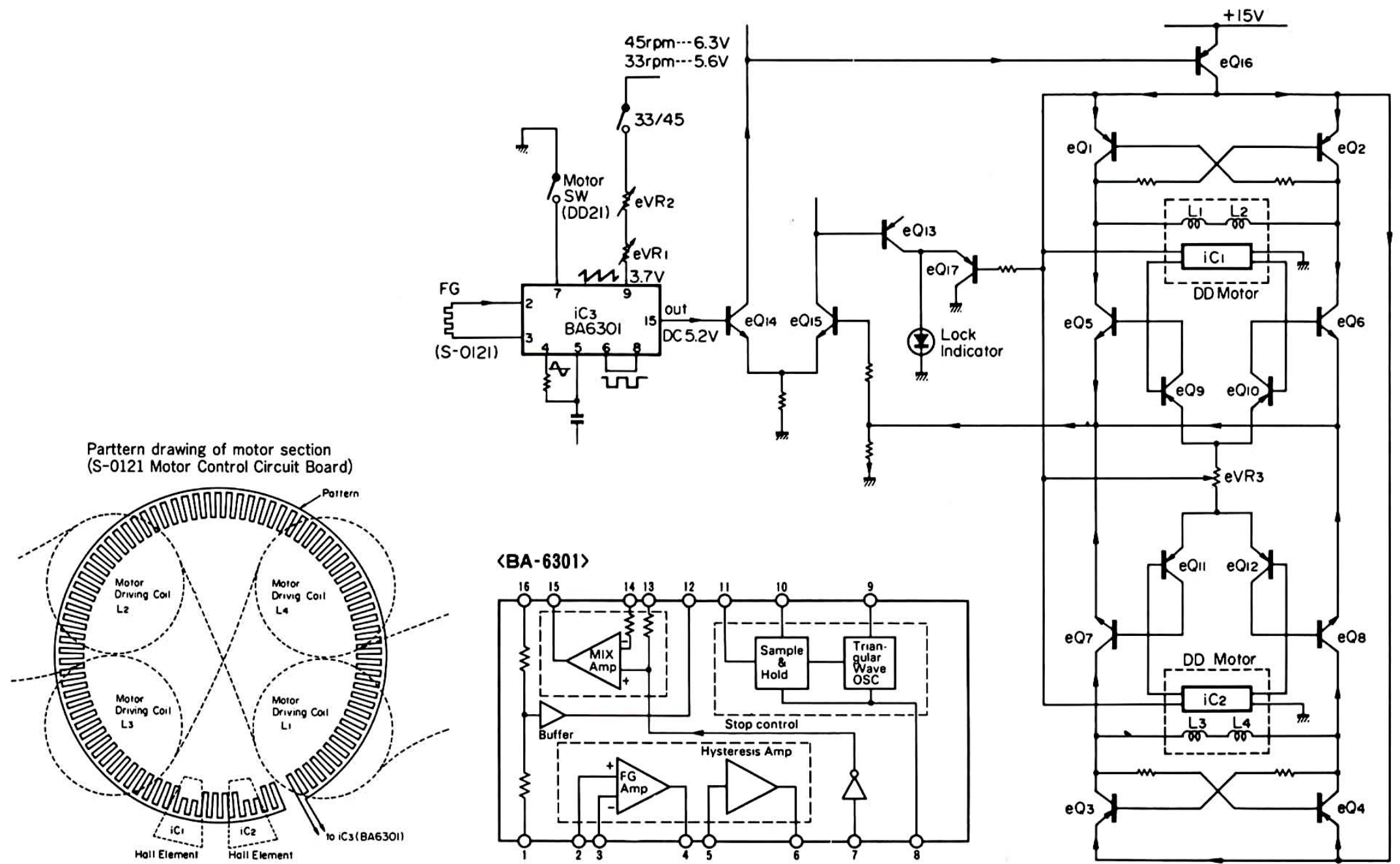

# 5. ADJUSTMENTS

## 5-1. Adjustment of the Auto Return

- 1) The adjusting screw in top view is one to adjust the position of Auto Return when stylus reaches lead-out groove.
- 2) Make adjustment of the screw in such a way that stylus lifts up automatically around the middle way of lead-out groove. Namely turn the adjusting screw clockwise is for leading and counterclockwise if for lagging.
- 3) After adjusting the screw properly, check its operation a few times.

## 5-2. Adjustment of the Clearance between PU plate and Micro Switch

After replacing the micro switch, adjust the clearance between PU plate and micro switch (See Fig. 5-1) to be approximately 0.3 mm at the tonearm on the arm rest by the clearance adjusting cam.

## 5-3. Adjustment of the main gear

When the main gear makes abnormal mechanical noise caused by touching to the pinion gear during playing record disc, adjust its position with cam 2 to make even clearance between the circular arc portion of the main gear and the pinion gear.

Fig. 5-1

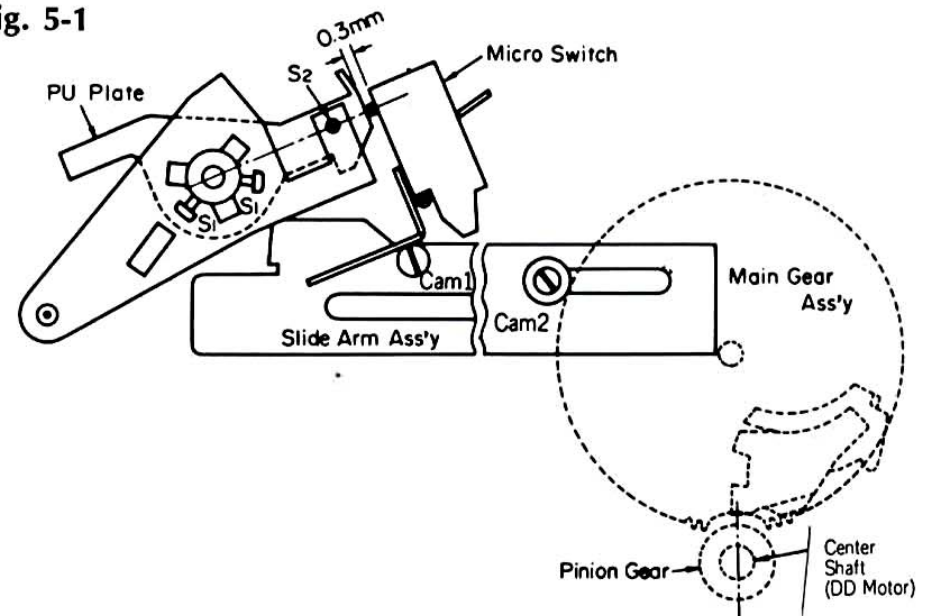

## 5-4. Speed Adjustment

•See Bottom View on page 4.

STEP	SPEED SELECTOR	ADJUST	ADJUST FOR
1.	33-1/3 r.p.m.	kVR1 (S-0121)	Strobo marking pattern appears to stand still.
2.	45 r.p.m.	kVR2 (S-0121)	Same as above

Note: Set kVR3 (S-0121) center position.

## 6. PACKING LIST

Parts No.	Stock No.	Description
1	—	Protector Board, upper
2	13142400	Dust Cover
3	—	Polyethylene Bag A
4	13140800	Turntable Sheet
		<XX, CSA, EU, BS, AS>
	13140900	Turntable sheet <UL>
5	13147210	Platter, turntable
6	13289200	Polyethylene Bag B
7	13170400	Styrofoam Packing, front
8	13170500	Styrofoam Packing, rear
9	—	Accessories Cover
10	—	Turntable Unit
11	91122710	Polyethylene Bag C
12	—	Arm Packing
13	—	Polyethylene Bag D
14	—	Inner Packing
15	13268700	Carton Case (Silver)
		<P-D11> ...with dust cover
	13268900	Carton Case (Silver)
		<P-D11> ...without dust cover
	13268800	Carton Case (Black)
		<P-D11> ...with dust cover
	13269000	Carton Case (Black)
		<P-D11> ...without dust cover
	13267500	Carton Case (Silver)
		<P-D21> ...with dust cover
	13267700	Carton Case (Silver)
		<P-D21> ...without dust cover
	13267600	Carton Case (Black)
		<P-D21> ...with dust cover
	13267800	Carton Case (Black)
		<P-D21> ...without dust cover

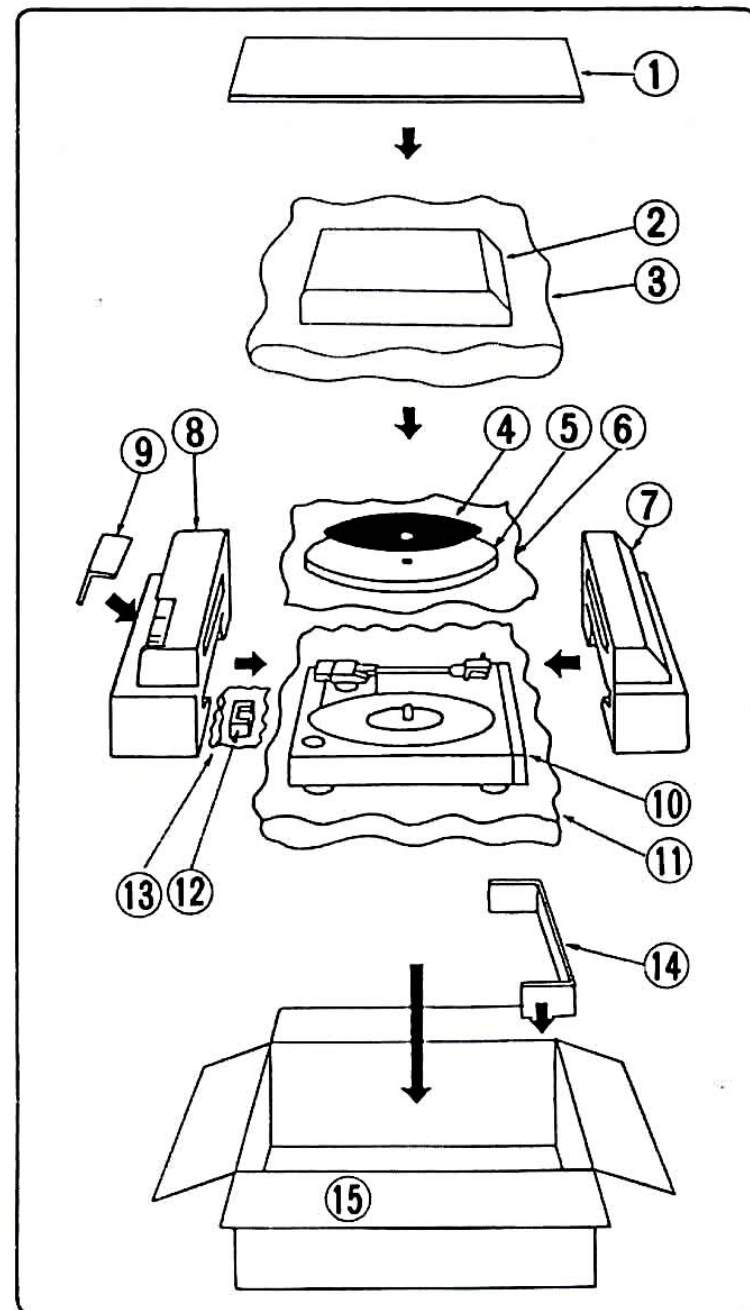

## 7. ACCESSORY LIST

Stock No.	Description
46932300	Operating Instruction <P-D11>
46932200	Operating Instruction <P-D21>
13283300	Cartridge, SV-P313
13283400	Stylus, SN-P313
13288800	Screw Ass'y

•Note: There are two types of units in P-D21/D11

- 1) The unit with a cartridge
  - 2) The unit without a cartridge
- The mark (E) is stamped on the side of carton case.



SANSUI ELECTRIC CO. LTD.:  
 SANSUI ELECTRONICS CORPORATION:  
 SANSUI ELECTRONICS (U.K.) LTD.:  
 SANSUI ELECTRONICS G.M.B.H.:

14-1, Izumi 2-chome, Sugunami-ku, Tokyo 168 Japan  
 PHONE: (03) 324-8891/TELEX: 232-2076 (International Division)  
 1250 Valley Brook Ave. Lyndhurst, N.J. 07071 U.S.A.  
 17150 South Margay Ave. Carson, California 90746 U.S.A.  
 3036 Koapaka Street. Honolulu, Hawaii 96819 U.S.A.  
 Unit 10A, Lyon Industrial Estate, Rockware Avenue, Genford, Middx UB6, OAA, England  
 Pau Ehrich Strasse 8, 6074 Rödermark 2, West Germany