

SERVICE MANUAL

COMPUTERIZED FULLY AUTOMATIC
DD TURNTABLE

SANSUI P-M77



CAUTION

1. Use only replacement parts recommended by the manufacturer.
2. Measure insulation resistance before returning the appliance to the customer to prevent electrical shock.

Sansui

SANSUI ELECTRIC CO., LTD.

•SPECIFICATIONS

Type.....	Direct-drive turntable
Rated speeds.....	33-1/3, 45 rpm
Platter.....	Aluminum alloy diecast, 306 mm (12-1/16") diameter, 0.6 kg (1.3 lbs.) weight
Motor	Coreless and Brushless DC/FG Servo
Wow/flutter	0.028% (WRMS)
Signal-to-noise ratio	Better than 72 dB (DIN-B) Better than 60 dB (IEC-B)
Tonearm	Statically-balanced type
Effective tonearm length	142 mm (5-5/8")
Cartridge.....	Dual Magnet type (SV-S707)
Output voltage.....	2.5 mV (1,000 Hz, 35.4 mm/sec)
Correct load impedance	47 kohms
Frequency response.....	10 ~ 20,000 Hz
Stylus.....	0.6 mil diamond stylus (SN-707 replacement stylus)
Others	
Power voltage	110 ~ 120/220 ~ 240V (50/60 Hz)
For U.S.A. and Canada	120 V (60 Hz)
Power consumption	20W
Dimensions.....	345 mm (13-5/8") W 99 mm (3-15/16") H 360 mm (14-3/16") D
Weight.....	5.5 kg (12.1 lbs.) net 6.4 kg (14.1 lbs.) packed

* Design and specifications subject to change without notice for improvements.

1. BLOCK DIAGRAM

•Tone Arm Control Section

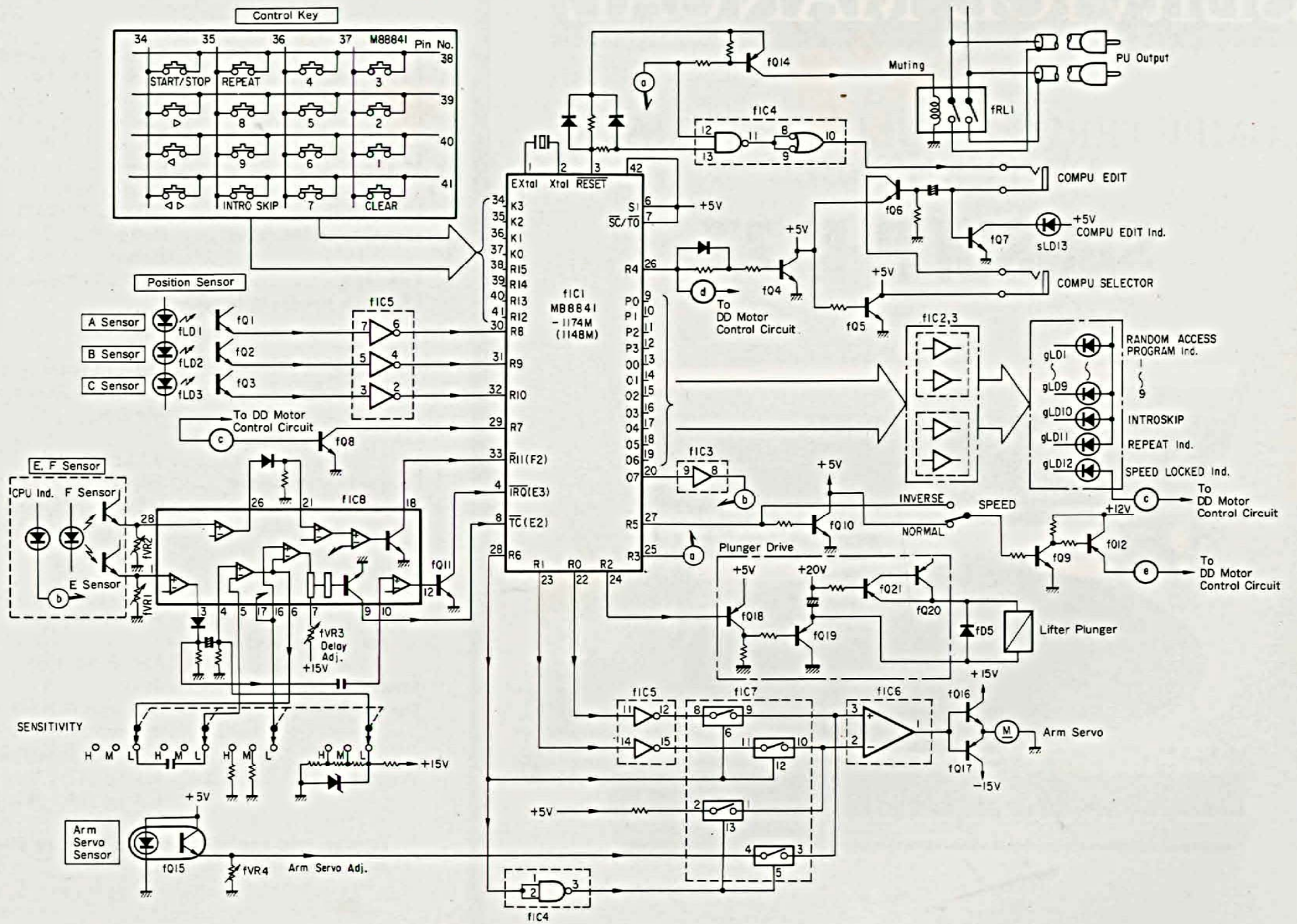

•Auto Mechanism

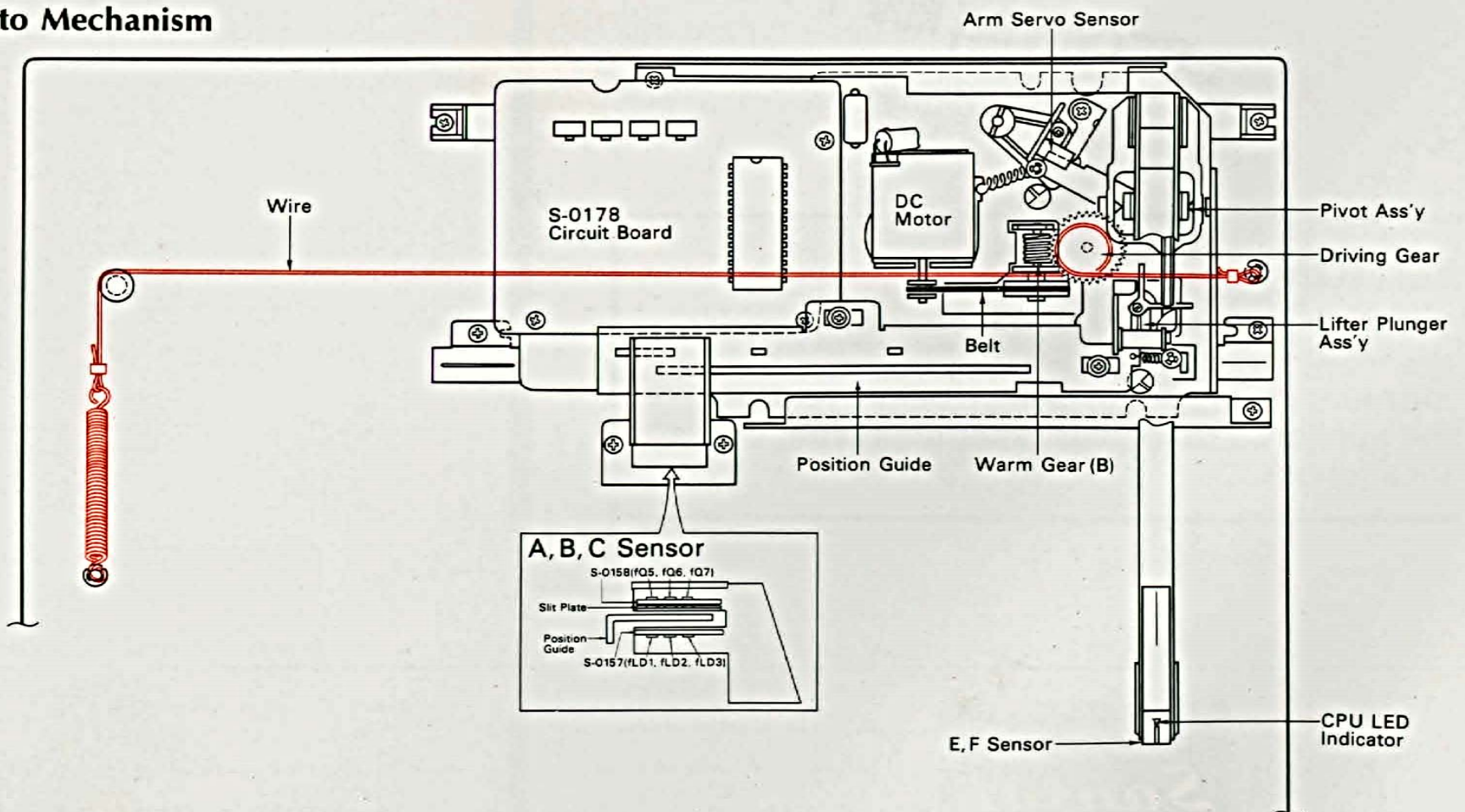

•DD Motor Control Section

Parttern drawing of motor section (S-0121 Motor Control Circuit Board)

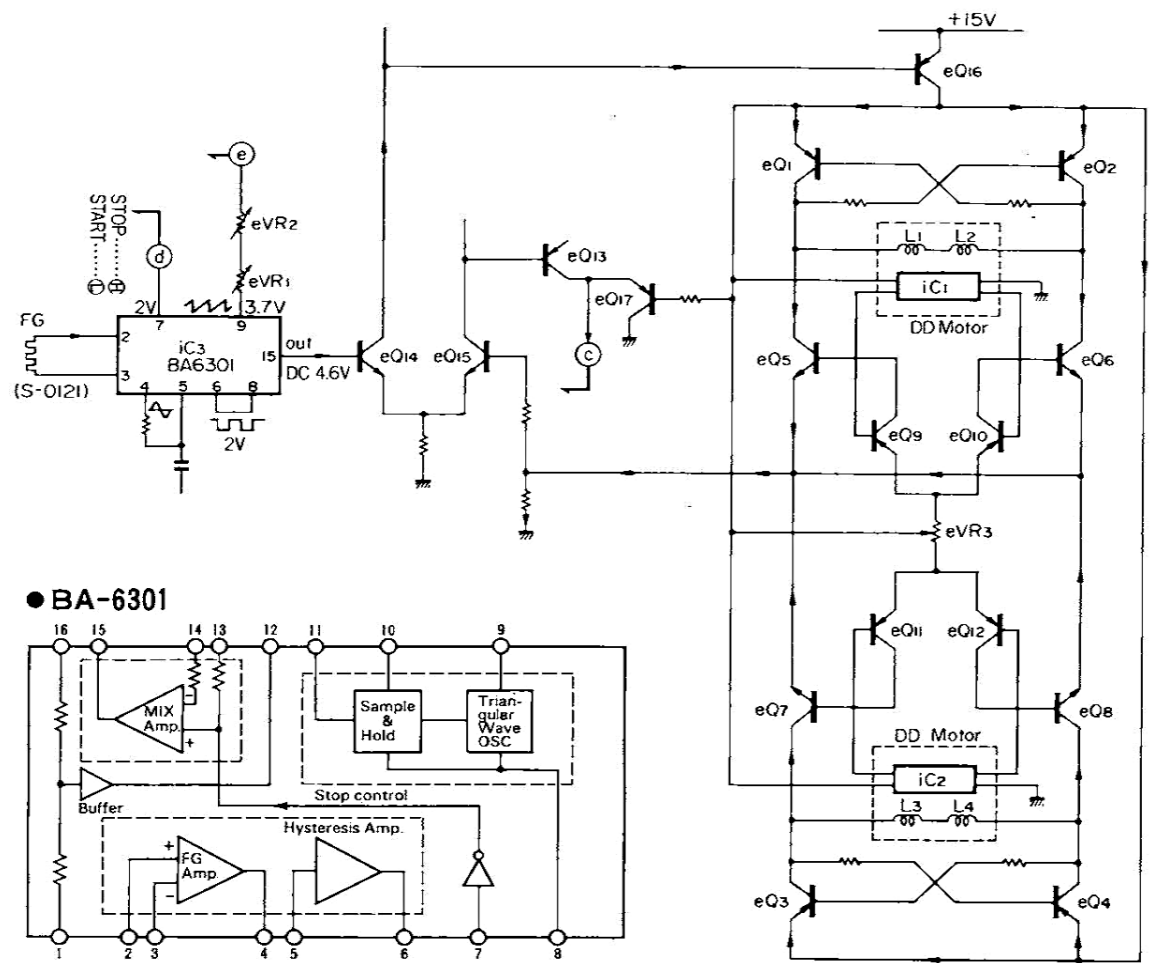
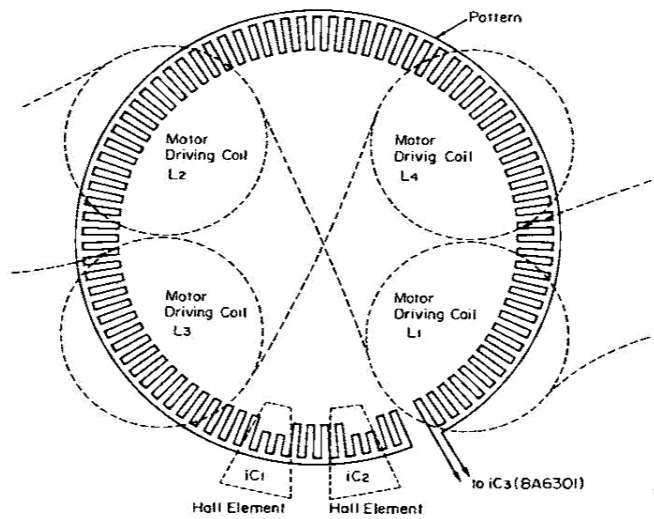

2. MICRO COMPUTER/MB8841-1174M TIMING CHART

2-1. AUTO MUSIC SELECTION Program 2-3-5 (Introskip) <30cm, 33rpm>

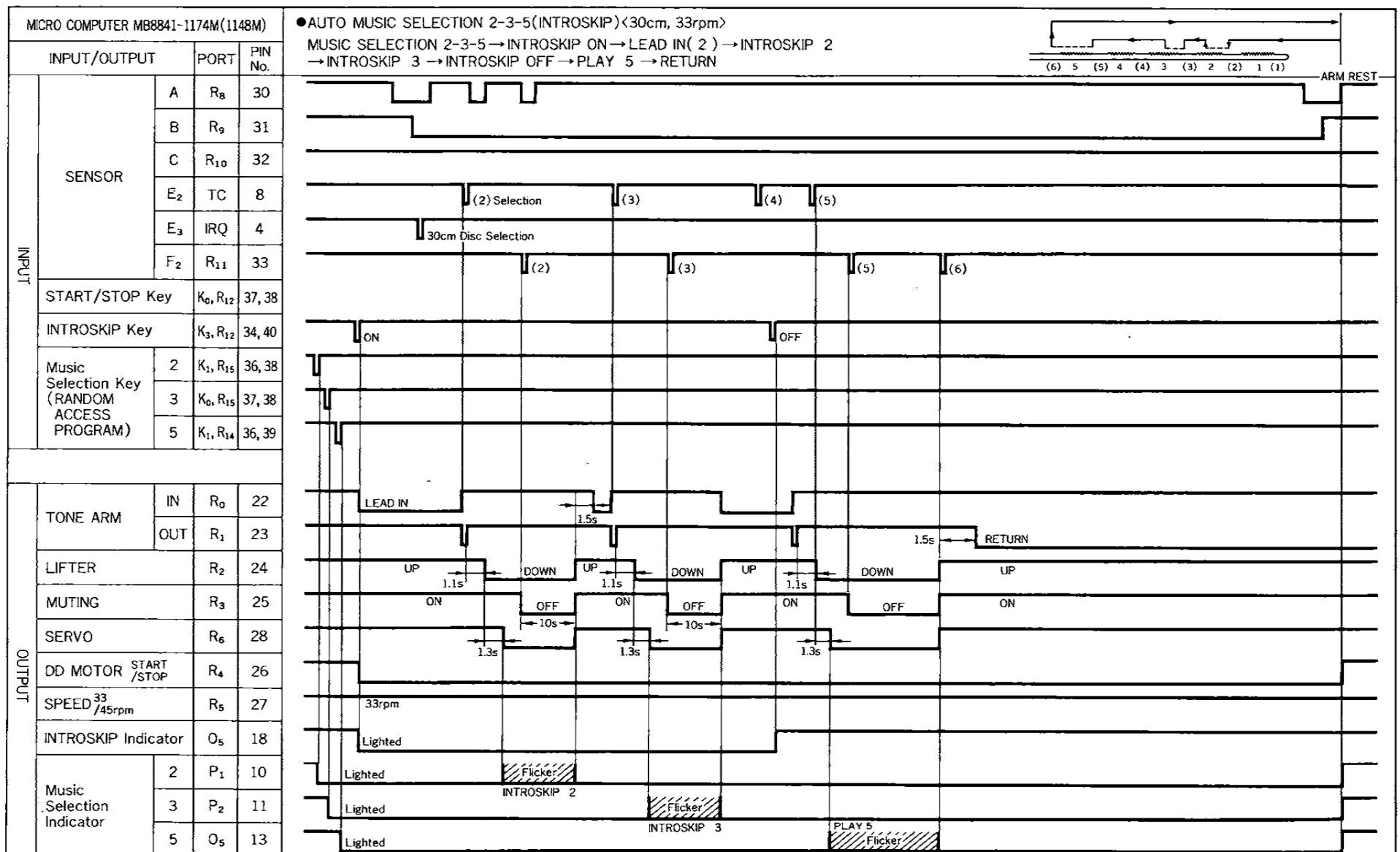

2-2. ALL INTROSKIP-MUSIC SELECTION Program-2 <30cm, 33rpm>

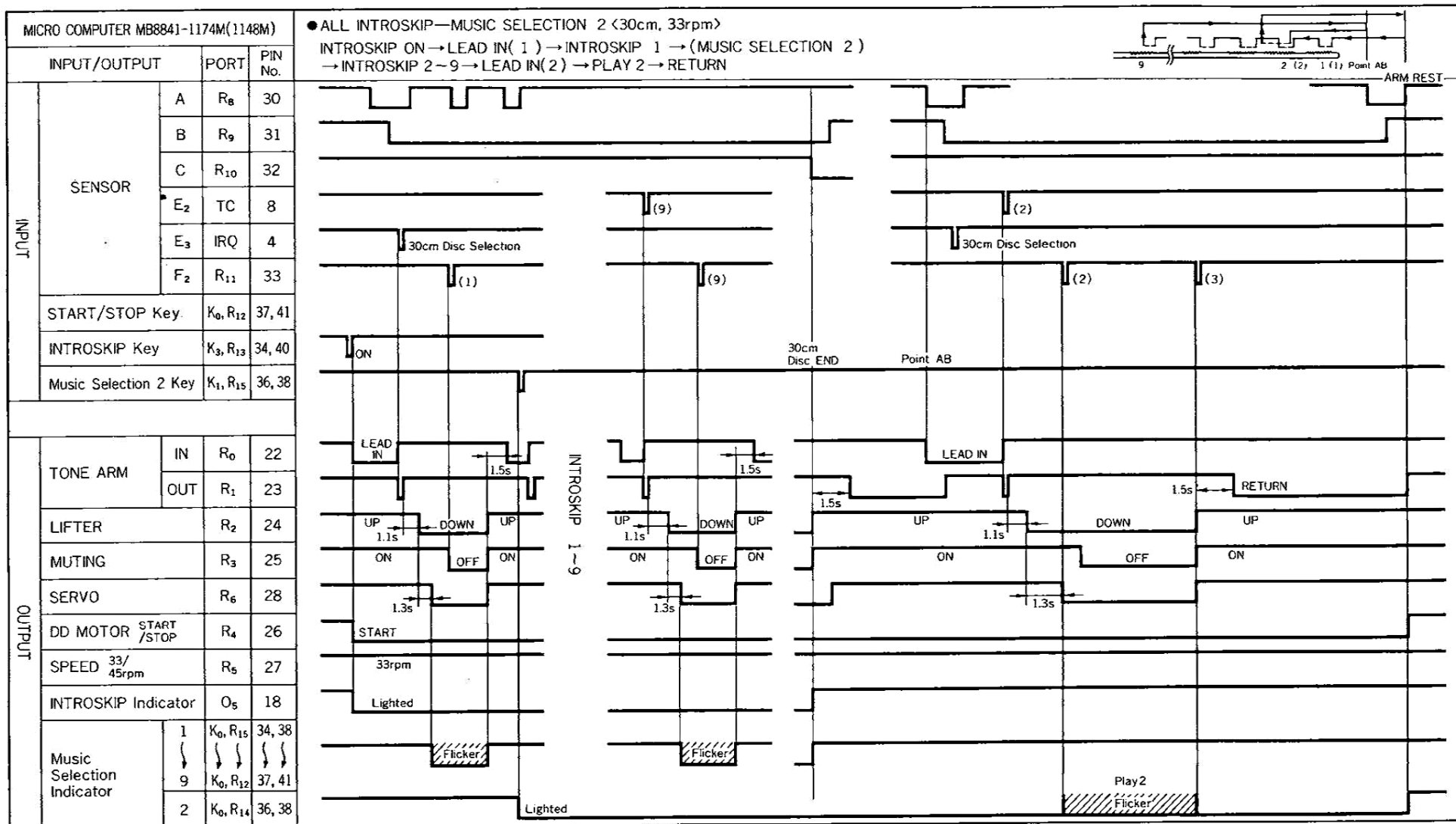

2-3. AUTOMATIC DISC SIZE DETECTION <17cm, 45rpm>

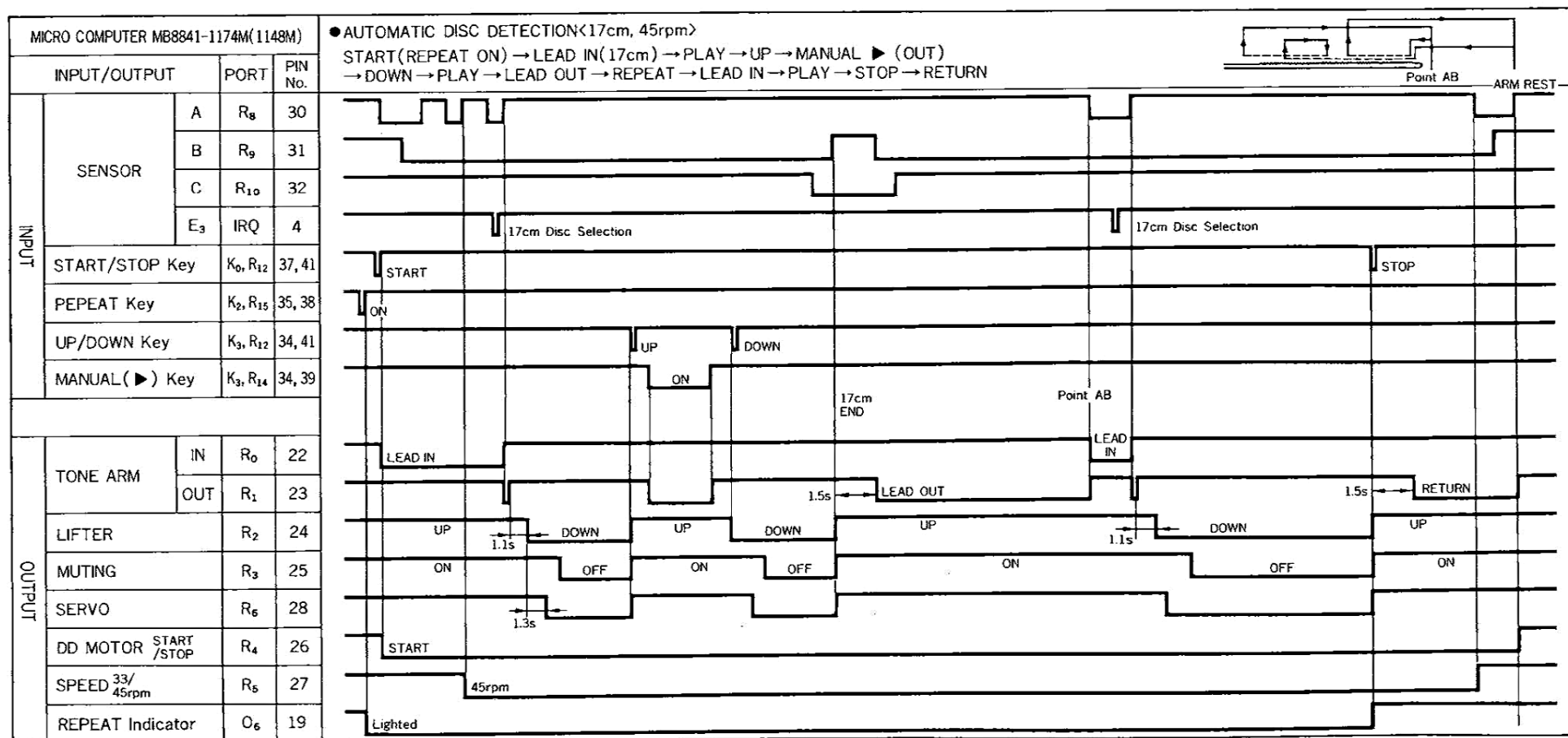

3. ADJUSTMENTS

Note: Before adjustments of 3-1, 3-2, 3-3 and 3-4, remove the player case cover only.

3-1. Adjustment of Automatic disc Size Selection Operation (See Figs. 3-1 and 3-3)

- 1) By using 30 cm size disc, actually carry out the automatic disc size selection operation (lead-in operation). Adjust the lead-in adjusting cam (See Fig. 3-3) so that the stylus tip may come down to the position (the lead-in groove position) 146~146.5 mm away from the disc center (See Fig. 3-1).
- 2) By using 17 cm size disc, actually carry out the automatic disc size selection operation (lead-in operation). Confirm that the stylus tip may come down to the lead-in groove position.

Fig. 3-1

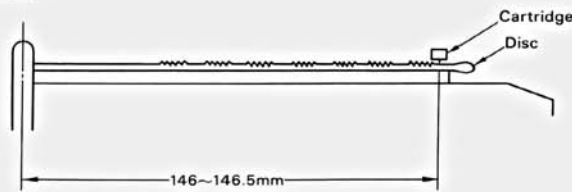

3-2. Adjustment of Automatic Music Selection Operation (See Figs. 3-2 (a), (b) and 3-3)

• Required disc and measuring instruments

- 1) Multi Meter (DC voltmeter)
Input impedance: 50kohm/V or more. (The higher, the better)
- 2) A vinyl chloride record disc without grooves or with wider leadout spiral than usual.
- 3) A rule with graduation marks starting from the edge.

A. Tone Arm Height Adjustment

Adjust the height as shown in Fig. 3-2 (a), (b) by rotating the tone arm height adjusting screw (See Fig. 3-3). (Stop the stylus at a position about 110 mm away from the disc center.)

Fig.3-2(a)

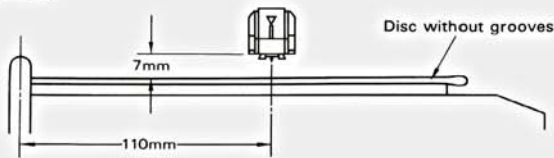

Fig.3-2(b)

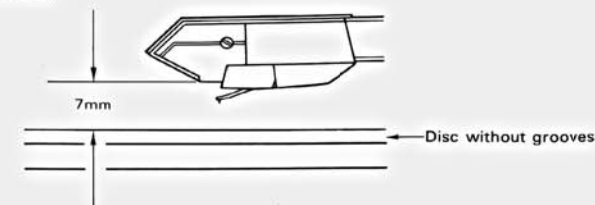
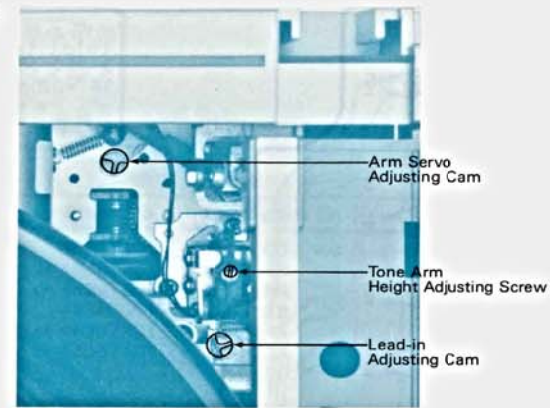

Fig. 3-3



B. Sensitivity adjustment of E and F sensor

1. Setting

At the tone arm position, in case of a record disc without grooves, stop the stylus at a position about 105 mm away from the disc center. In case of a record disc having grooves, stop the stylus above the flat surface nears 105 mm away from the disc center.

2. How to adjust (See Fig. 3-4)

- a) At the tone arm up position, connect the DC voltmeter across the test terminal "E" and "G (ground)" (S-0178) and then adjust the voltage to DC 2.5V by rotating the volume (fVR1, S-0178). <E sensor adjustment>
- b) Move the tone arm downward.
- c) Connect the DC voltmeter across the test terminal "F" and "G (ground)" and then adjust the voltage to DC 2.5V by rotating the volume (fVR2, S-0178). <F sensor adjustment>

Note: When adjusting both the sensors with the stylus stopped on a lead-over groove of an ordinary record disc, note that there is a difference in detection position between E sensor (leading sensor) and F sensor.

Fig. 3-4

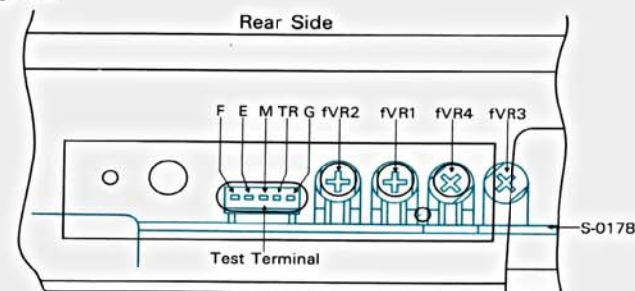

3-3. Delay adjustment of E₂ signal

- The E₂ signal is a music number counting signal required for moving down the tone arm at a desired music position during the automatic music selection operation.

1. Objective

- a) Since the E sensor is located about 2 mm before the stylus, it is necessary to electrically delay the signal from the E sensor.
- b) Since some of the mechanical parts are moved with accuracy of the order of milliseconds, it is necessary to adjust error due to mechanical operation.
- c) Since detection error occurs due to an eccentricity of the record disc, it is necessary to adjust the error.

2. Setting

Use the record disc with narrower music intervals.

3. Adjustment (See Figs. 3-5, 3-6, 3-7 and Top View on page 8)

- a) Perform the respective lead-in operation for selected music track, and adjust the operation by rotating the volume (fVR3, S-0178) as shown in Fig. 3-6, 3-7 (with the tone arm placed on the arm rest) so that the stylus comes down on or a little before the lead-over grooves for the music track. If the volume (fVR3, S-1078) is rotated clockwise, the lift-down position of the stylus is shifted inward. However, if the stylus comes down before the lead-over grooves, be sure that the muting switch is turned off within 20 sec after the stylus moves down. The muting time from 4 to 6 sec is desirable.

Fig. 3-5

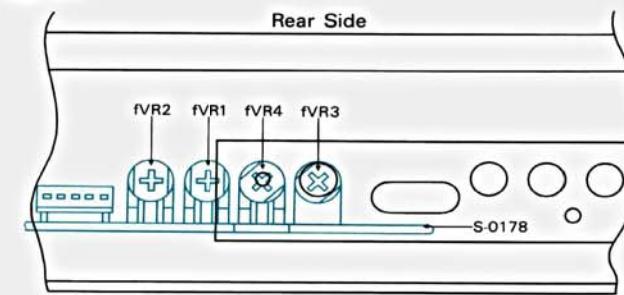

Fig. 3-6

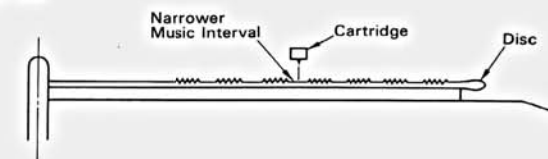
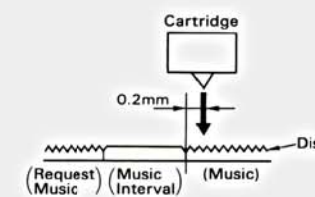

Fig. 3-7



3-4. Lateral-direction Adjustment of E and F Sensor

* If automatic music selection play is insufficient by adjustments 3-2 and 3-3, perform the following.

1. Setting

- a) Mount a record disc in which many music groove.
- b) Set the sensitivity selection switch to H when the music interval groove is narrow, and to M when medium.

2. How to adjust (See Figs. 3-8 and 3-9)

- a) Push the music selection switch for the first music, and also the start/stop switch.
- b) Immediately after the stylus begins to come down, move the arm by hand so that the stylus may trace the disc groove beginning from a position 2 mm or more outward from the lead-over groove.
- c) Immediately after the above tracing, push the lifter switch twice. Be sure to push it with a time interval of 1 sec or more, because of a ready operation to receive F₂ signal.
- d) Adjust the positions of E and F sensor by rotating the adjusting screws so that the muting switch can be turned ON (a click sound of relay action is heard) when the stylus has passed through the music interval groove. If the muting switch is turned ON earlier, rotate the adjusting screw clockwise to turn ON the switch later. (The thread pitch is 0.45 mm.)

* Perform adjustments 3-2 and 3-3 shown left accordingly after completion of 3-4. Lateral-direction Adjustment of E and F sensor.

Fig. 3-8

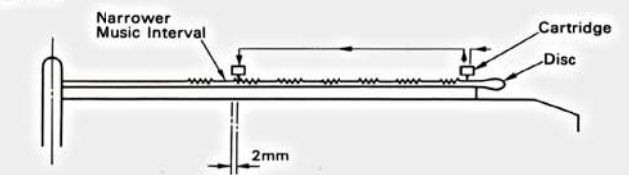
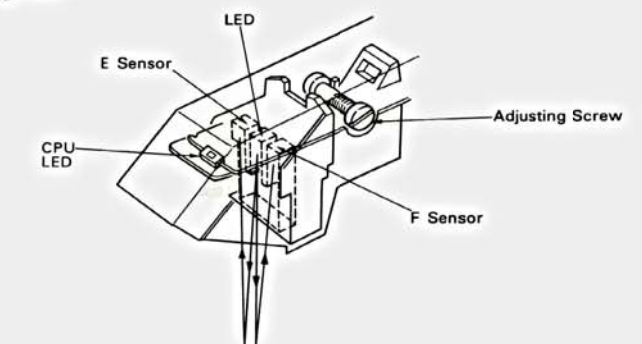

Fig. 3-9



3-5. Speed Adjustment

- 1-a) Set the Speed Selector to Normal.
- 1-b) Mount a 30 cm size record disc and push the start/stop switch.
- 1-c) Adjust eVR1 on the D.D. Motor Control Circuit Board (See Fig. 3-10) so as to standstill the strobo marking pattern.
- 2-a) Set the Speed Selector to Normal.
- 2-b) Mount a 17 cm size record disc and push the start/stop switch.
- 2-c) Adjust eVR2 on the D.D. Motor Control Circuit Board (See Fig. 3-10) so as to standstill the strobo marking pattern.

- Set eVR3 (S-0121) center position.

Fig. 3-10

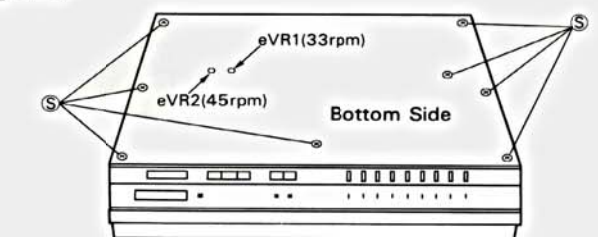

Note: Remove the cabinet before adjustments of 3-6.

- **How to remove the cabinet.** (See Top View on Page 8)
 - 1) Take off turntable sheet and turntable platter.
 - 2) Remove the play case cover.
 - 3) Loosen 8 screws (S) to remove cabinet. (See Fig. 3-10)
 - 4) Remove the cabinet upward slowly.

* Do not strike tone arm with the cabinet.

3-6. Arm Servo Signal Adjustment

(See Figs. 3-3, 3-11, 3-12 and 3-13)

- 1) Move the tone arm leftward and stop the stylus at a position about 105 mm away from the disc center by depressing the MANUAL (◀) key.
- 2) Connect the DC voltmeter across the test terminal "TR" and "G" shown in Fig. 3-12.
- 3) The tone arm servo level goes up more when the tone arm is moved rightward slightly by hand.
- 4) Adjust the voltage of "item 3)" to DC 4V by rotating the volume (fVR4).
- 5) Move the tone arm downward by depressing UP/DOWN key.
- 6) Rotate the arm servo adjusting cam slowly clockwise just right before the tone arm starts moving outwards, then read the indication on DC voltmeter.
- 7) Next, rotate the arm servo adjusting cam slowly counterclockwise just right before the tone arm starts moving inwards, then read the indication as well.
- 8) Set the fixed value to average voltage between two indications obtained in 6) and 7) above, by rotating (fVR4).
- 9) Connect the DC voltmeter across the test terminal "M" and "G" (See Fig.3-13) and then confirm that the voltage is within ±1V.
- 10) Check that the tone arm will not move in either direction when the UP/DOWN key is depressed repeatedly, if necessary, rotating the volume (fVR4) slightly.

Fig. 3-11

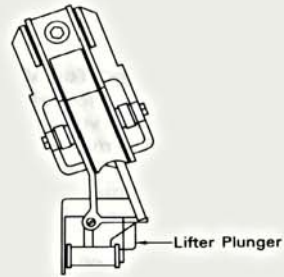

Fig. 3-12

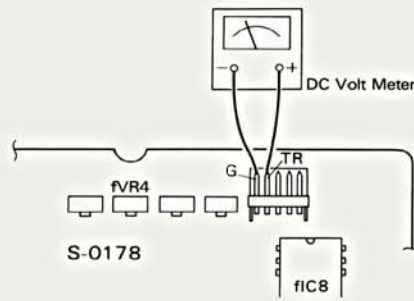
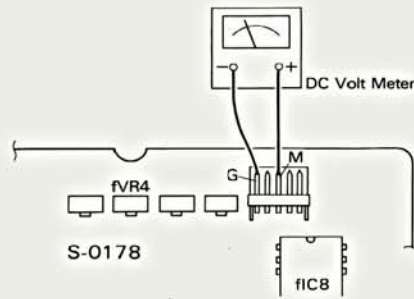
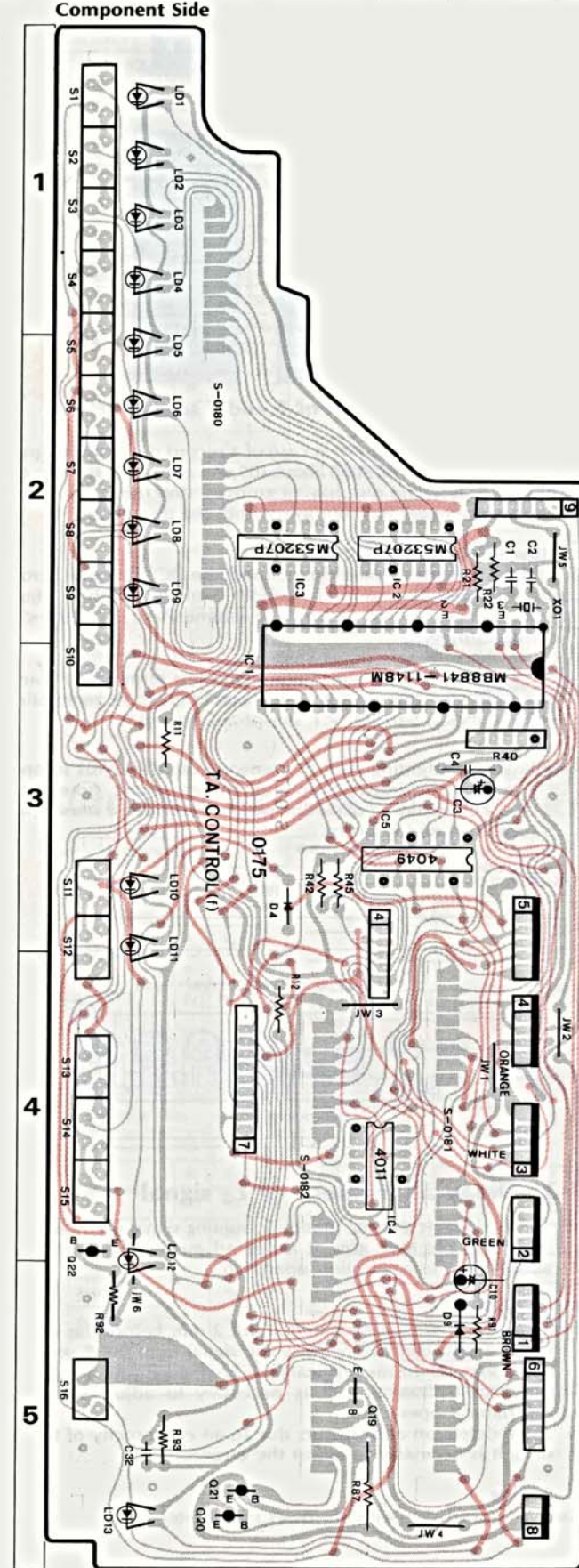

Fig.3-13



4-2. S-0175 Tone Arm Control (Main) Circuit Board (Stock No. 13218901)



Parts List		
Parts No.	Stock No.	Description
• Transistor		
fQ19	46501401	2SD1226
fQ20	46501301	2SB910M
fQ21	07299601	2SA1115
	or 46078701	2SA1048
	or 07197001	2SA733
• Diode		
fD4	03111600	1S2473D
fD9	03111600	1S2473D
• IC		
fIC1	46602500	MB8841-1148M
	or 46602501	MB8841-1174M
fIC2	46220600	M53207P
fIC3	46220600	M53207P
fIC4	03604000	MSM4011RS
	or 03604100	TC4011BP
	or 07207200	MB84011BM
	03611800	MSM4049RS
	or 46160400	MB84049BM
fXO1	46505500	Ceramic Element KBR-3.58M
fR87	00145900	150Ω 2W N.I.R.
• LED		
gLD1	46606400	SLP-960C (Red)
gLD2	46606400	SLP-960C (Red)
gLD3	46606400	SLP-960C (Red)
gLD4	46606400	SLP-960C (Red)
gLD5	46606400	SLP-960C (Red)
gLD6	46606400	SLP-960C (Red)
gLD7	46606400	SLP-960C (Red)
gLD8	46606400	SLP-960C (Red)
gLD9	46606400	SLP-960C (Red)
gLD10	46606400	SLP-960C (Red)
gLD11	46606400	SLP-960C (Red)
gLD12	46173900	SLP-270C (Green)
gLD13	46606400	SLP-960C (Red)
gSW1	46394200	Push SW. (Tact) RANDOM ACCESS PROGRAM
gSW2	46394200	Push SW. (Tact) RANDOM ACCESS PROGRAM
gSW3	46394200	Push SW. (Tact) RANDOM ACCESS PROGRAM
gSW4	46394200	Push SW. (Tact) RANDOM ACCESS PROGRAM
gSW5	46394200	Push SW. (Tact) RANDOM ACCESS PROGRAM
gSW6	46394200	Push SW. (Tact) RANDOM ACCESS PROGRAM
gSW7	46394200	Push SW. (Tact) RANDOM ACCESS PROGRAM
gSW8	46394200	Push SW. (Tact) RANDOM ACCESS PROGRAM
gSW9	46394200	Push SW. (Tact) RANDOM ACCESS PROGRAM
gSW10	46394200	Push SW. (Tact), CLEAR
gSW11	46394200	Push SW. (Tact), REPEAT
gSW12	46394200	Push SW. (Tact), INTROSkip
gSW13	46394200	Push SW. (Tact), UP/DOWN
gSW14	46394200	Push SW. (Tact), MANUAL ◀
gSW15	46394200	Push SW. (Tact), MANUAL ▶
gSW16	46394200	Push SW. (Tact), START/STOP

4. PARTS LOCATION & PARTS LIST

4-1. S-0178 Tone Arm Control (Sub) Circuit Board (Stock No. 13219201)

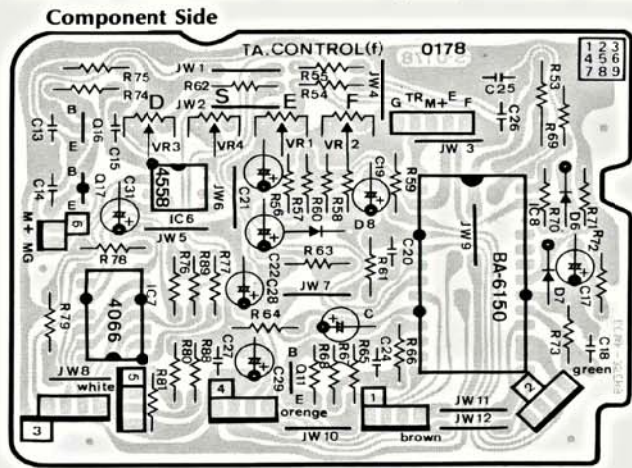

Parts List		
Parts No.	Stock No.	Description
• Transistor		
fQ11	07299701	2SC2603
	or 46078801	2SC2458
	or 03059501	2SC945
fQ16	46614100	2SC3243
fQ17	46614000	2SA1283
• IC		
fIC6	03607700	NJM4558D
	or 46580100	M5218P
fIC7	07264600	MSM4066RS
fIC8	or 46164300	MB84066BM
	46321300	BA6150
• Diode		
fD6	03117600	1S2473T77
fD7	03117600	1S2473T77
fD8	03117600	1S2473T77
fC17	46408100	22μF 25V E.C.
fVR1	46180500	200kΩ S.V.R, E sensor adj.
fVR2	46180500	200kΩ S.V.R, F sensor adj.
fVR3	46180600	500kΩ S.V.R, delay adj.
fVR4	46180100	10kΩ S.V.R, arm servo adj.

• Since some of capacitors and resistors are omitted from parts lists in this service manual, refer to the Common Parts List for capacitors & resistors, which was issued on February 1983.

4-3. S-0181 Compu•Edit/Compu•Selector Circuit Board (Stock No. 13224501)

Component Side

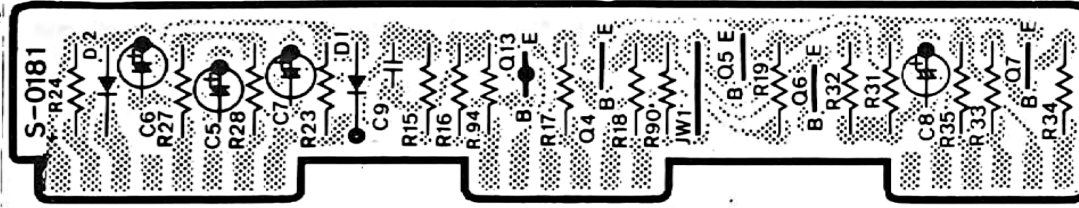

Parts List

Parts No.	Stock No.	Description	Parts No.	Stock No.	Description
•Transistor			fQ7	46367101	2SC2603
fQ4	46367101	2SC2603	or 46367301	2SC2458	
	or 46367301	2SC2458	or 46367501	2SC945A	
	or 46367501	2SC945A	fQ13	46367001	2SA1115
fQ5	46367101	2SC2603	or 46367201	2SA1048	
	or 46367301	2SC2458	or 46367401	2SA733A	
	or 46367501	2SC945A			
fQ6	46367101	2SC2603	•Diode		
	or 46367301	2SC2458	fD1	03117600	1S2473D
	or 46367501	2SC945A	fD2	03117600	1S2473D

4-4. S-0182 Motor Control Circuit Board (Stock No. 13224601)

Component Side

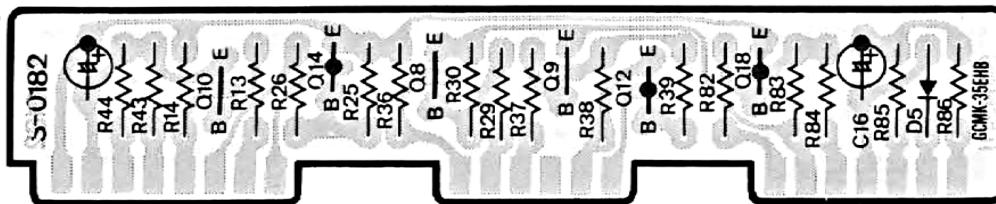

Parts List

Parts No.	Stock No.	Description	Parts No.	Stock No.	Description
•Transistor			fQ12	46367001	2SA1115
fQ8	46367101	2SC2603	or 46367201	2SA1048	
	or 46367301	2SC2458	or 46367401	2SA733A	
	or 46367501	2SC945A	fQ14	46367001	2SA1115
fQ9	46367101	2SC2603	or 46367201	2SA1048	
	or 46367301	2SC2458	or 46367401	2SA733A	
	or 46367501	2SC945A	fQ18	46367001	2SA1115
fQ10	46367101	2SC2603	or 46367201	2SA1048	
	or 46367301	2SC2458	or 46367401	2SA733A	
	or 46367501	2SC945A	•Diode		
			fD5	036117600	1S2473D

•Note: The circuit boards, S-0174, S-0121, S-0157, S-0158, S-0173, S-0177, S-0176 & S-0180 are not supplied as the assembled. However, the individual parts on the circuit boards are provided orders.

4-5. S-0174 Power Supply Circuit Board

Component Side

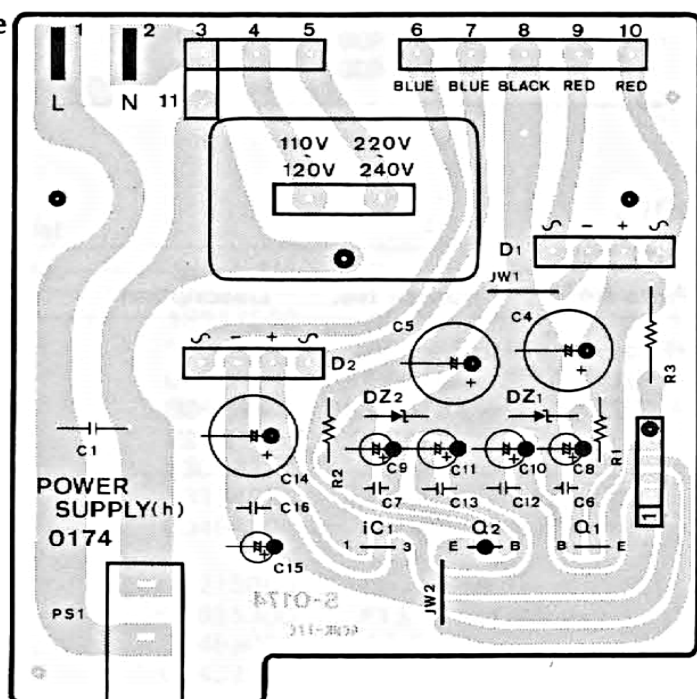

Parts List

Parts No.	Stock No.	Description
•Transistor		
hQ1	03083902	2SD313
hQ2	46149301	2SB744
•IC		
hIC1	07183500	μPC78M05H
	or 46144200	NJM78M05A
•Diode		
hD1	03117000	RB-152
hD2	03117000	RB-152
•Zener Diode		
hDZ1	46104500	05Z16-X
hDZ2	46104500	05Z16-X
hR3	46618000	33Ω 2W N.I.R.
hC1	46425800	10000pF 400V C.C
hSW1	46413900	Push SW., POWER

4-6. S-0121 DD Motor Control Circuit Board

Component Side

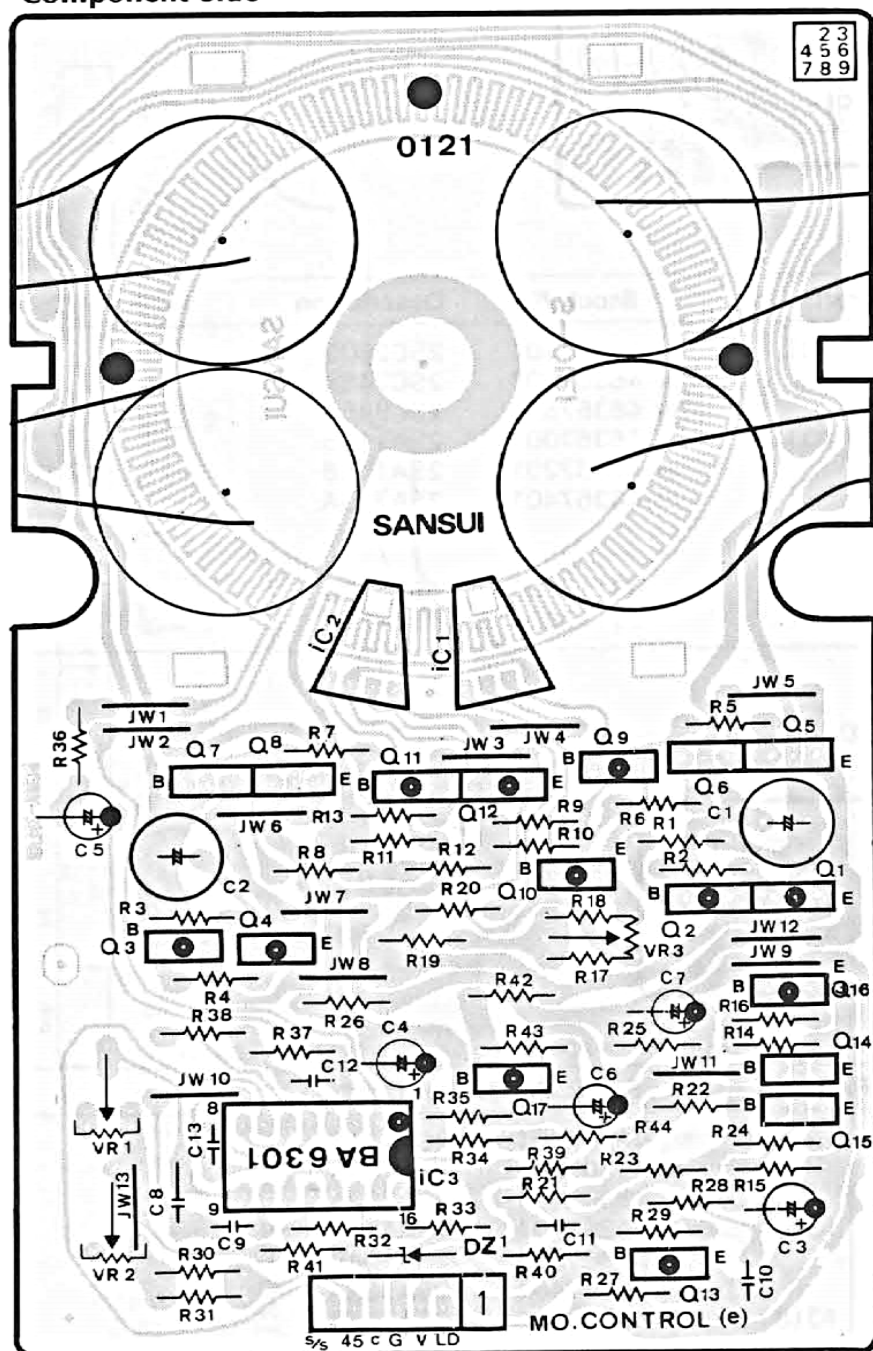

Parts List

Parts No.	Stock No.	Description
•Transistor		
eQ1	46359701	2SA952
eQ2	46359701	2SA952
eQ3	46359701	2SA952
eQ4	46359701	2SA952
eQ5	46359801	2SC2001
eQ6	46359801	2SC2001
eQ7	46359801	2SC2001
eQ8	46359801	2SC2001
eQ9	46367401	2SA733A
	or 46367001	2SA1115
	or 46367201	2SA1048
eQ10	46367401	2SA733A
	or 46367001	2SA1115
	or 46367201	2SA1048
eQ11	46367401	2SA733A
	or 46367001	2SA1115
	or 46367201	2SA1048
eQ12	46367401	2SA733A
	or 46367001	2SA1115
	or 46367201	2SA1048
eQ13	46367001	2SA1115
	or 46367201	2SA1048
eQ14	46367101	2SC2603
	or 46367301	2SC2458
eQ15	46367101	2SC2603
	or 46367301	2SC2458
eQ16	46149301	2SB744
eQ17	46614001	2SA1283
	or 46367201	2SA1048
•IC		
eIC1	46354301,2	H-300BC
eIC2	46354301,2	H-300BC
eIC3	46354400	BA6301
•Zener Diode		
eDZ1	46113900	05Z12-Y
eR41	46530800	240kΩ 1/4W M.R
eC1	08451100	22μF 16V E.C
eC2	08451100	22μF 16V E.C
eVR1	46366600	100kΩ(B) S.V.R, 33r.p.m.
eVR2	07241700	200kΩ(B) S.V.R, 45r.p.m.
eVR3	07241000	1kΩ(B) S.V.R, wow and flutter

4-7. S-0157 A, B, C Senser (LED) Circuit Board

Component Side

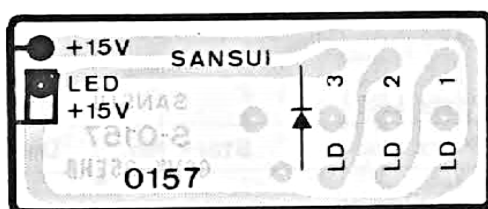

Parts List

Parts No.	Stock No.	Description
•LED		
fLD1	46150400	TLR121
fLD2	46150400	TLR121
fLD3	46150400	TLR121

4-8. S-0158 A, B, C Senser (Photo Transistor) Circuit Board

Component Side



Parts List

Parts No.	Stock No.	Description
•Photo Transistor		
fQ1	46160000	TPS605
fQ2	46160000	TPS605
fQ3	46160000	TPS605

4-9. S-0173 Muting Relay Circuit Board

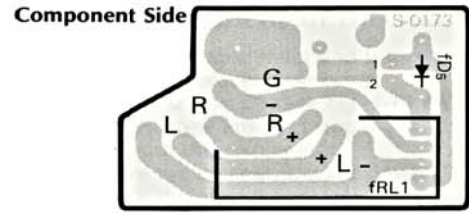

Parts No.	Stock No.	Description
•Diode fD3	03111600	1S2473
fRL1	46173300	Relay

4-10. S-0177 Arm Servo Sensor Circuit Board

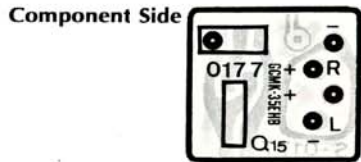

Parts No.	Stock No.	Description
fQ15	46603900	Photo Coupler GP-1S03

4-11. S-0176 SENSITIVITY, NORMAL/INVERSE Switch Circuit Board

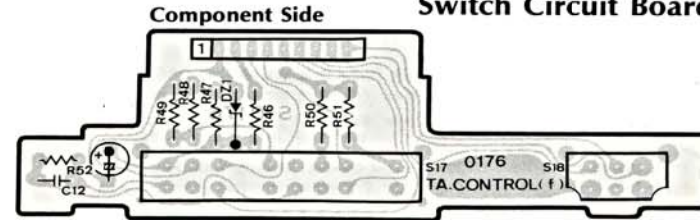

Parts No.	Stock No.	Description
•Zener Diode fDZ1	46103100	05Z10-Y
gSW17	46133500	Slide SW., SENSITIVITY
gSW18	46133600	Slide SW., Speed

4-12. S-0180 Indicator Circuit Board

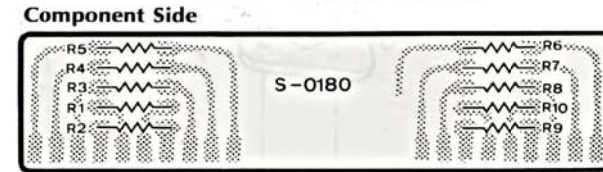

•Abbreviations

C.R. : Carbon Resistor	E.B. : Bi-Polar Electrolytic Capacitor
S.R. : Solid Resistor	E.BL. : Low Leak Bi-Polar Electrolytic Capacitor
Ce.R. : Cement Resistor	Ta.C. : Tantalum Capacitor
M.R. : Metal Film Resistor	F.C. : Film Capacitor
F.R. : Fusing Resistor	M.P. : Metalized Paper Capacitor
N.I.R. : Non-Inflammable Resistor	P.C. : Polystyrene Capacitor
C.C. : Ceramic Capacitor	G.C. : Gimmic Capacitor
C.T. : Ceramic Capacitor, Temperature Compensation	V.R. : Variable Resistor
E.C. : Electrolytic Capacitor	S.V.R. : Semi Variable Resistor
E.L. : Low Leak Electrolytic Capacitor	SW. : Switch

5. OTHER PARTS

Parts No.	Stock No.	Description
1	18075100	Tone Arm Ass'y with cartridge SV-S707
2	13228400	SN-707 Stylus
3	13209100	Player Case Cover
4	13209400	Push Knob Ass'y(A) START/STOP, MANUAL, UP/DOWN, REPEAT, INTROSKIP
5	46394200	Push SW. START/STOP, MANUAL, UP/DOWN, REPEAT, INTROSKIP
6	13216500	Slide Knob, SENSITIVITY, SPEED
7	46133600	Slide SW., SPEED
8	46133500	Slide SW., SENSITIVITY
9	13209500	Push Knob Ass'y, RANDOM ACCESS PROGRAM 1-9, CLEAR
10	13214500	Control Plate
11	13219900	Push Knob, POWER
12	46413900	Push SW., POWER
13	13159710	Turntable Platter
14	13099110	Turntable Sheet
15	13012300	EP Adaptor
16	13213600	Hinge
17	13208700	Dust Cover Ass'y
13097310		Insulator

Parts No.	Stock No.	Description
1	46413200	Power Supply Cord
2	39106000	Strain Relief
3	46170400	Jack, COMPU-SELECTOR, COMPU-EDITING
4	13222400	P.U. Output Cord
5	39105700	Strain Relief
6	13220300	Pipe
7	13106200	Pipe Holder
8	13220400	Drive Wire
9	00489200	E-Ring 3φ
10	13216400	Angle Rail
11	18032300	DD Motor with Control Circuit Board S-0121
12	13212000	Power Switch Guide
13	15008301	Power Transformer
14	13220500	Tension Spring

5-1. Front View

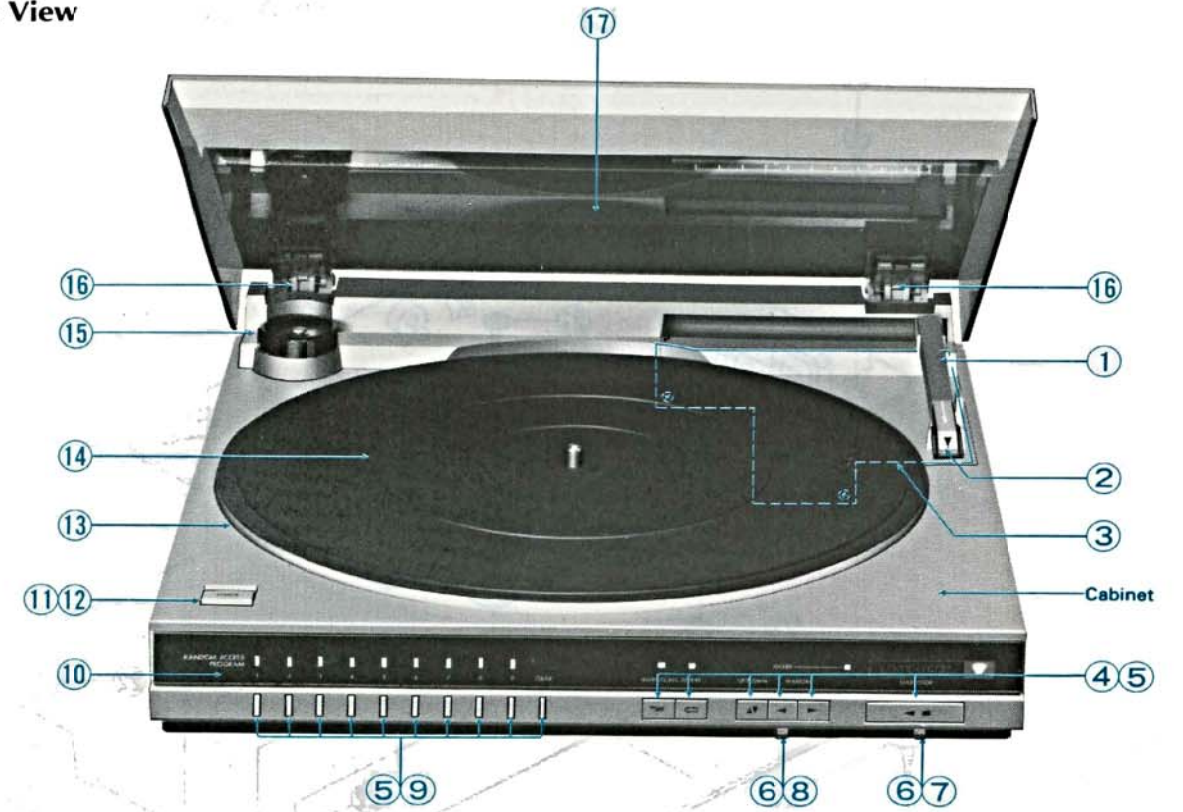

5-2. Top View

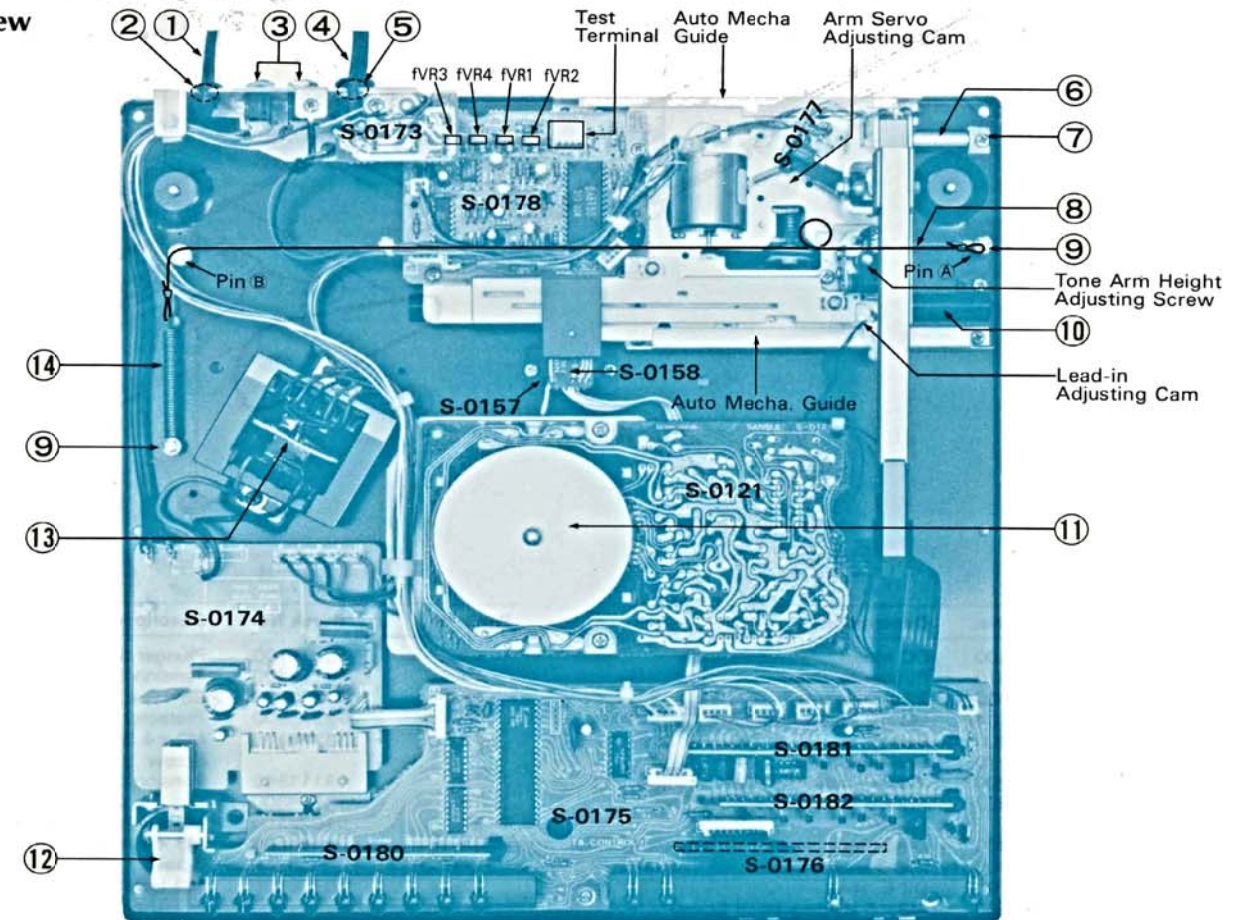

6. EXPLODED VIEW OF AUTO MECHANISM & PARTS LIST

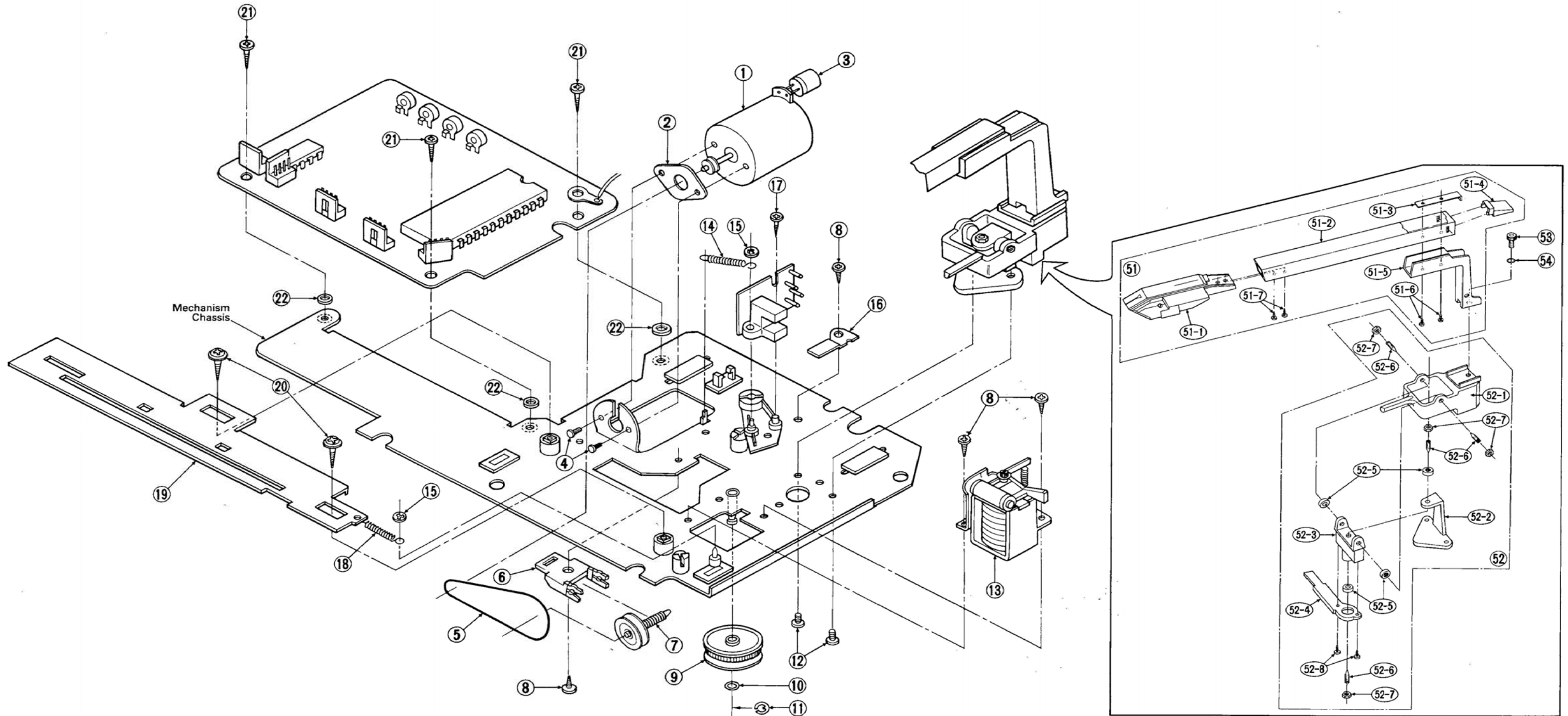

Parts List

Parts No.	Stock No.	Description
1	13217500	DC Motor
2	55029810	Rubber Cushion
3	00305600	22 μ F 25V E.B.
4	00436500	M4 x 2 Pan Head Screw
5	13103800	Belt
6	13098110	Shaft Guide (B)
7	13134200	Warm Shaft Ass'y (B)
8	00454400	M3 x 6 Binding Head Tapping Screw
9	13215800	Drive Gear
10	51825300	FT3 Thrust Washer
11	00489000	D2 E. Ring
12	00421900	M3 x 6 Binding Head Screw

Parts No.	Stock No.	Description
13	13216100	Plunger Solenoid Ass'y
14	13111400	Tension Spring (1)
15	51830000	CS-Type Washer
16	13225900	Protector Plate
17	13226100	M2 x 4 Binding Head Tapping Screw
18	13111500	Tension Spring (2)
19	13216000	Position Guide
20	51625100	M3 x 8 Pan Head Tapping Screw
21	00454500	M3 x 8 Binding Head Tapping Screw
22	13226000	M9 Isolation Washer

Parts List

Parts No.	Stock No.	Description
51	18075100	Tone Arm Ass'y
51-1	—	SV-S707 Cartridge Ass'y
51-2	—	Pipe
51-3	—	GND Rag
51-4	—	Pipe Cover
51-5	—	Pipe Holder
51-6	—	M2 x 4 Pan Head Screw
51-7	—	M2 x 4 Pan Head Tapping Screw
52	18075200	Pivot Ass'y
52-1	—	Arm Bracket

Parts No.	Stock No.	Description
52-2	—	Pivot Stay
52-3	—	Pivot Holder
52-4	—	Servo Plate
52-5	—	Pivot Bearing
52-6	—	Pivot
52-7	—	M3 Hexagon Nut
52-8	—	M2 x 6 Pan Head Tapping Screw
53	00453500	M4 x 8 Hexagon Socket Head Screw
54	00469800	D4 Spring Washer

7. SCHEMATIC DIAGRAM

*Design and specifications subject to change without notice for improvement.
*La présentation et les spécifications sont susceptibles d'être modifiées sans préavis par suites d'améliorations éventuelles.
*Änderungen, die dem technischen Fortschritt dienen, bleiben vorbehalten.

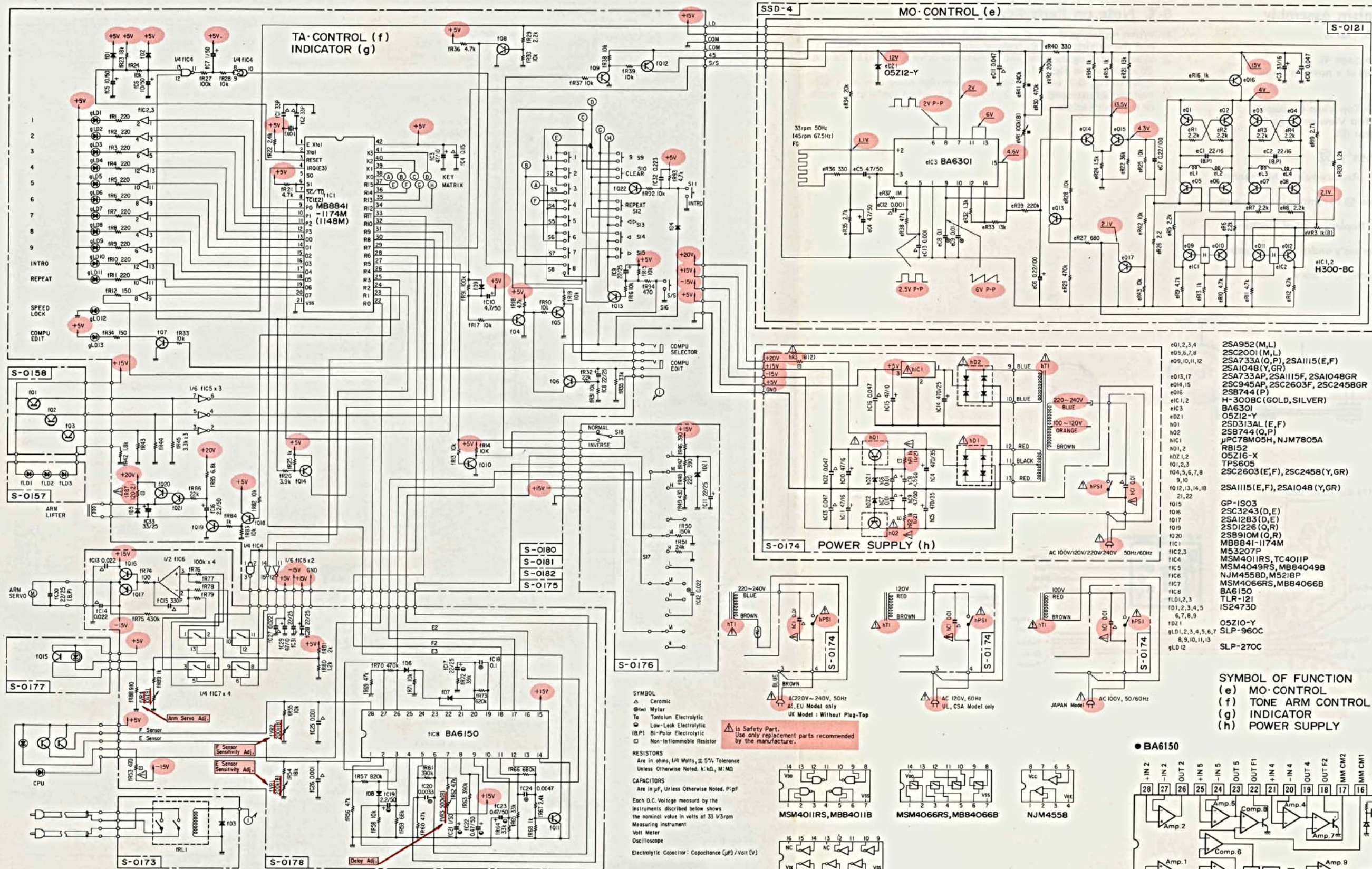

SYMBOL
 ▲ Ceramic
 ⊙/⊖ Mylar
 T Tantulum Electrolytic
 ● Low-Leak Electrolytic
 (B.P) Bi-Polar Electrolytic
 □ Non-Inflammable Resistor

RESISTORS
 Are in ohms, 1/4Watts, ±5% Tolerance
 Unless Otherwise Noted. k:k1, M:MD

CAPACITORS
 Are in μF, Unless Otherwise Noted. P:pF

Each D.C. Voltage measured by the instruments described below shows the nominal value in volts of 33 1/3rpm Measuring Instrument
 Volt Meter
 Oscilloscope
 Electrolytic Capacitor: Capacitance (μF) / Volt (V)

⚠ Is Safety Part.
 Use only replacement parts recommended by the manufacturer.

UK Model: Without Plug-Top

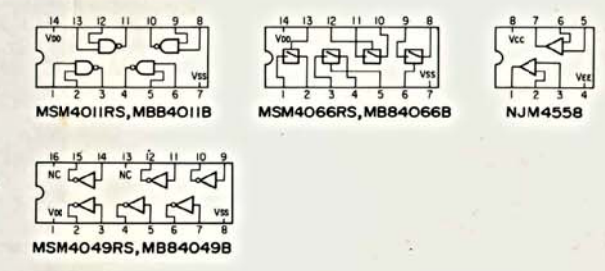

- e01, 2, 3, 4
 - e05, 6, 7, 8
 - e09, 10, 11, 12
 - e013, 17
 - e014, 15
 - e016
 - e1C, 1, 2
 - e1C3
 - e021
 - n01
 - n02
 - n01C1
 - n01, 2
 - n02, 1, 2
 - 101, 2, 3
 - 104, 5, 6, 7, 8
 - 9, 10
 - 1012, 13, 14, 18
 - 21, 22
 - 1015
 - 1016
 - 1017
 - 1019
 - 1020
 - 1021
 - 1022
 - 1012, 1, 3
 - 101, 2, 3, 4, 5
 - 6, 7, 8, 9
 - gD1
 - gD1, 2, 3, 4, 5, 6, 7
 - 8, 9, 10, 11, 13
 - gD12
- 2SA952 (M,L)
 - 2SC2001 (M,L)
 - 2SA733A (O,P), 2SA1115 (E,F)
 - 2SA1048 (Y,GR)
 - 2SA733AP, 2SA1115F, 2SA1048GR
 - 2SC945AP, 2SC2603F, 2SC2458GR
 - 2SB744 (P)
 - H-300BC (GOLD, SILVER)
 - BA6301
 - OSZ12-Y
 - 2SD313AL (E,F)
 - 2SB744 (O,P)
 - PC78M05H, NJM7805A
 - RB152
 - OSZ16-X
 - TPS605
 - 2SC2603 (E,F), 2SC2458 (Y,GR)
 - 2SA1115 (E,F), 2SA1048 (Y,GR)
 - GP-1S03
 - 2SC3243 (D,E)
 - 2SA1283 (D,E)
 - 2SD1226 (O,R)
 - 2SB910M (O,R)
 - MBB841-1174M
 - M53207P
 - MSM4011RS, TC4011P
 - MSM4049RS, MBB4049B
 - NJM4558D, M5218P
 - MSM4066RS, MBB4066B
 - BA6150
 - TLR-121
 - IS2473D
 - OSZ10-Y
 - SLP-960C
 - SLP-270C

SYMBOL OF FUNCTION
 (e) MO CONTROL
 (f) TONE ARM CONTROL
 (g) INDICATOR
 (h) POWER SUPPLY

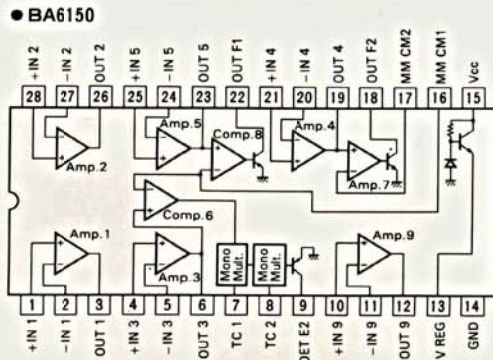

- 2SA1283
- 2SC3243
- 2SA952
- 2SA733A
- 2SC945
- 2SC2001
- 2SA1048
- 2SA1115
- 2SC2458
- 2SC2603
- 2SB744
- 2SD313
- 2SB910M
- 2SD1226
- PC78M05H
- NJM7805H
- M5218P
- NJM4558D
- MBB4011BM
- MSM4011RS
- TC4011BP
- MBB4049BM
- MSM4049RS
- MSM4066RS
- MSM4066B
- MBB4066B
- BA6150
- BA6301
- MBB841-1174M (1148M)
- M53207P
- 1S2473D
- RB152
- OSZ-10Y
- OSZ12-Y
- OSZ16-Y

1

2

3

4

5

8. MAIN PARTS REPLACEMENT (See Top View on page 8 and Exploded View of Auto Mechanism on page 9)

8-1. Replacement of Mechanism Assembly

- 1) Take off turntable sheet and turntable platter.
- 2) Remove the player case cover.
- 3) Loosen 8 screws ⑤ (See Fig. 3-10 on page 4).
- 4) Move the tone arm and stop the stylus at a position about 10 cm away from the disc center.
- 5) Remove the cabinet upward slowly.
- 6) Remove the auto mecha. guide. (See Top View on page 8)
- 7) Remove the wire from pin ③. (See Top View on page 8)
- 8) Take off the wire from the driving gear ⑨.

8-2. Replacement of Pivot Ass'y ⑫

- 1) Perform the items 1), 2), 3) and 4) "8-1. Replacement of Mechanism Ass'y" first.
- 2) Loosen the hexagon socket head screw ⑬ to remove the tone arm ass'y ⑩.
- 3) Perform the items 6), 7) and 8) "8-1. Replacement of Mechanism Ass'y."
- 4) Remove two screws ⑭ fixing the pivot ass'y under the mechanism chassis.
- 5) Take off the pivot ass'y from the mechanism ass'y.

8-3. Note on Parts Replacement

- 1) When replacing the shaft guide (B) ⑥, the worm gear ass'y (B) ⑦ and the driving gear ⑨, remove under the mechanism chassis.
- 2) When installing the wire, wind round the drive gear and fit the pin ④ as shown in Fig. 8-1.
- 3) Refer to Fig. 8-2, when wiring from cartridge (tone arm ass'y ⑩).
- 4) Perform adjustments 3-1, 3-2, 3-3 and 3-6, when replacing a parts of the mechanism ass'y.

Fig. 8-1

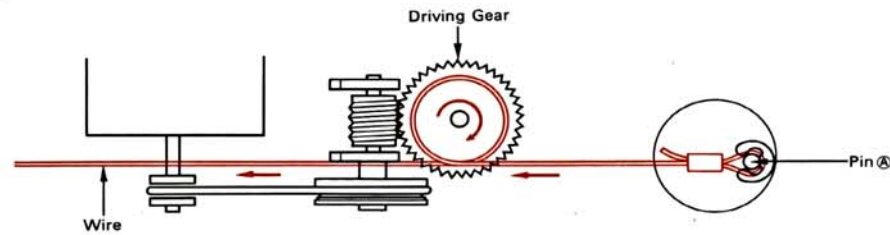
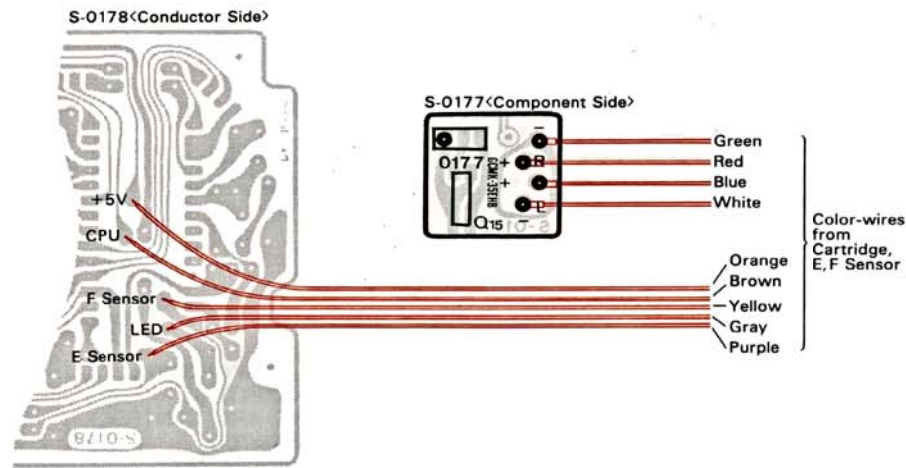

Fig. 8-2



9. PACKING LIST

Parts No.	Stock No.	Description
1	—	Cargated Board
2	91166000	Vinyl Bag, Rubber Mat
5	13186800	M4 x 25 Tapping Screw
6	51829200	Tag Washer
8	13012300	45 Adaptor
9	13163210	Spacer
10	13211600	Styrofoam Packing (Left)
11	—	Binder
13	91122710	Vinyl Bag, Turntable
14	13211500	Styrofoam Packing (Right)
15	13220600	Protector, Auto Mechanism
16	00449700	M4 x 12 Pan Head SEMS Screw
17	13219600	Carton Case

10. ACCESSORY LIST

Stock No.	Description
46558000	Operating Instruction
46611200	Operating Sheet
46267300	Mini Plug Cord, COMPU SELECTOR

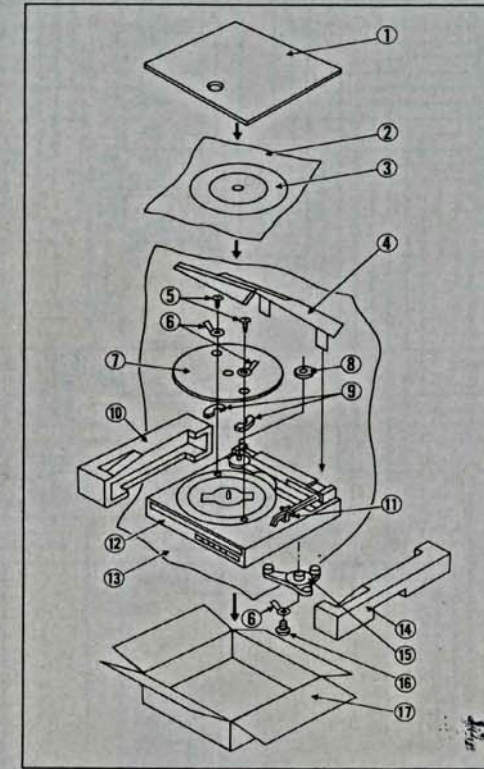

SANSUI ELECTRIC CO., LTD.:

SANSUI ELECTRONICS CORPORATION:

SANSUI ELECTRONICS (U.K.) LTD.:
SANSUI ELECTRONICS G.M.B.H.:

14-1, Izumi 2-chome, Sugunami-ku, Tokyo 168 Japan
PHONE: (03) 324-8891/TELEX: 232-2076 (International Division)
1250 Valley Brook Ave. Lyndhurst, N.J. 07071 U.S.A.
333 West Alondra Blvd. Gardena, California 90247 U.S.A.
3036 Koapaka 5t, Honolulu, Hawaii 96819 U.S.A.
Unit 10A, Lyon Industrial Estate, Rockware Avenue, Greenford, Middx UB6, OAA, England
Paul Ehrlich Strasse 8, 6074 Rödermark 2, West Germany

(SM1-94)

Printed in Japan (630620M) <Stock No. 36481800>