

SERVICE MANUAL

4-CHANNEL RECEIVER

SANSUI QR-4500

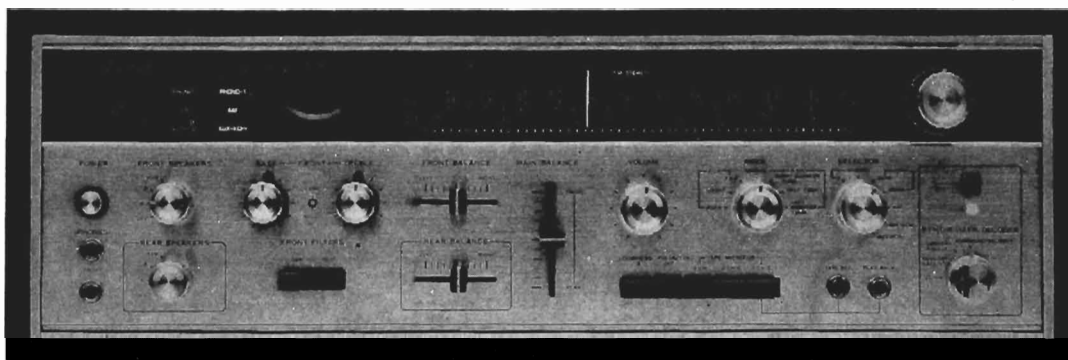

Sansui

SANSUI ELECTRIC COMPANY LIMITED

CONTENTS

GENERAL TROUBLESHOOTING CHART	3, 4
DISASSEMBLY PROCEDURE	5, 6
TEST POINTS	7
SCHEMATIC DIAGRAMS	8, 9, 10, 11
ALIGNMENT	12, 13, 14
PRINTED CIRCUIT BOARDS AND PARTS LIST	
..... 15, 16, 17, 18, 19, 20, 21, 22, 23, 24, 25, 26, 27, 28, 29	
OTHER PARTS AND THEIR POSITION ON CHASSIS	
.....	30, 31, 32

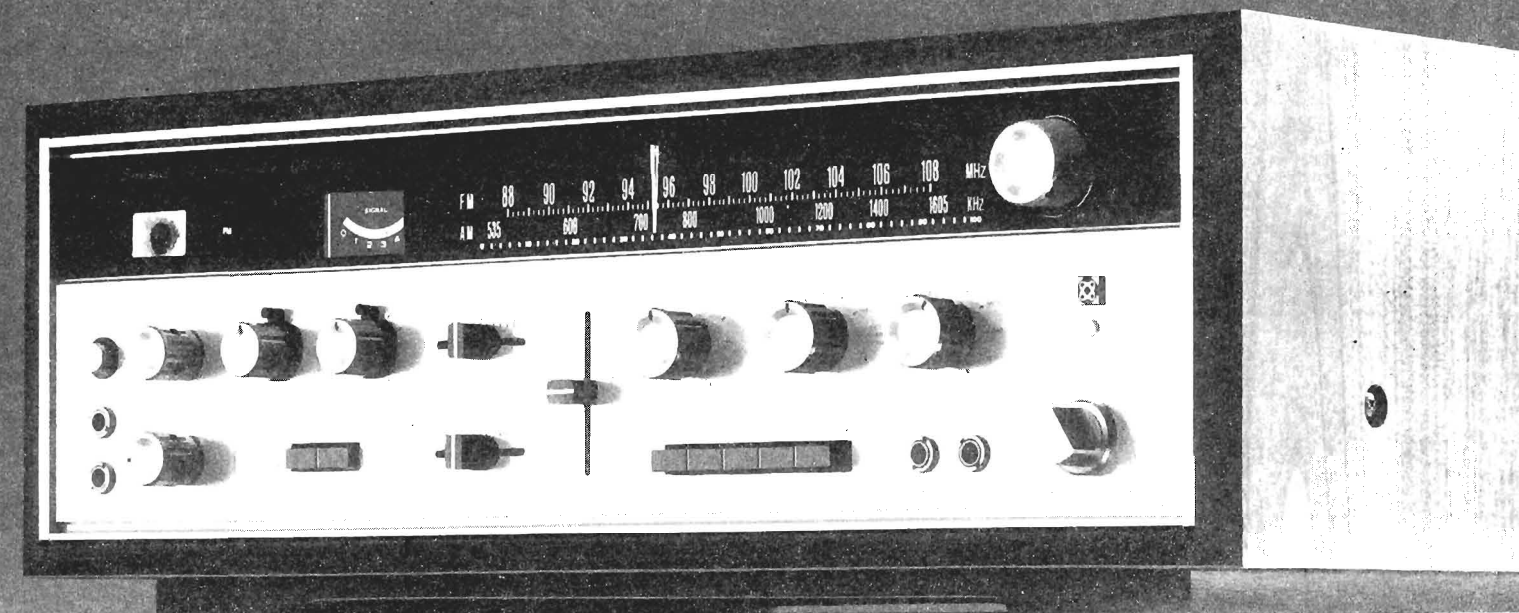

GENERAL TROUBLESHOOTING CHART

If the receiver is otherwise operating satisfactorily, the more common causes of trouble may generally be attributed to the following:

1. Incorrect connections or loose terminal contacts. Check the speakers, turntable, tape deck, antenna and power cord.
2. Improper operation. Before operating any audio com-

- ponent, be sure to read its manufacture's instructions.
3. Improper location of audio components. The proper positioning of components, such as speakers and turntable, is essential to the maximum stereo enjoyment.
 4. Defective audio components.
- The following are some other common causes of malfunction and what to do about them.

PROGRAM	SYMPTOM	PROBABLE CAUSE	WHAT TO DO
AM, FM or MPX reception	A. Constant or intermittent noise heard at times or in certain areas	<ul style="list-style-type: none"> * Discharge or oscillation caused by electrical appliances, such as fluorescent lamp, TV set, D.C. motor rectifier or oscillator. * Natural phenomena, such as atmospheric, static or thunderbolts * Insufficient antenna input due to ferroconcrete wall or long distance from station 	<ul style="list-style-type: none"> * Attach noise limiter to electrical appliance producing noise, or attach it to the receiver's power source * Install outdoor antenna and ground receiver to raise SN ratio * Reverse power cord plug/receptacle connections * If noise occurs at certain frequency, attach wave trap to input * Keep receiver at proper distance from other electrical appliances
AM reception	A. Noise heard at a particular time of a day, in a certain area or over part of dial	* Peculiar to AM broadcasts	<ul style="list-style-type: none"> * Install antenna for maximum antenna efficiency. See "RADIO RECEPTION" in operating instructions booklet * In some cases, noise can be eliminated by grounding receiver or reversing power cord plug/receptacle connections
	B. High-frequency noise	<ul style="list-style-type: none"> * Adjacent-channel interference or beat interference * TV set too close to audio system 	<ul style="list-style-type: none"> * Such noise cannot be completely eliminated by the receiver, but it is advisable to turn Treble control counterclockwise turn on High Filter * Keep TV set at proper distance from stereo system
FM reception	A. Noisy	<ul style="list-style-type: none"> * Poor noise limiter effect or too low SN ratio due to insufficient antenna input <p>Note: FM reception is affected considerably by transmission conditions of station, such as power and antenna efficiency. As a result, you may receive one station quite well while receiving another station poorly.</p>	<ul style="list-style-type: none"> * Install antenna (supplied) for maximum signal strength * If this does not prove effective, use exclusive FM outdoor antenna. If using TV antenna for both TV and FM with a divider, make sure TV reception is not affected * Exclusively long lead-in wire of antenna may cause noise
	B. A series of pops	* Ignition noise caused by starting of nearby automobile engine	* Install antenna and its lead-in wire at proper distance from street or increase antenna input as described before
	C. Tuning noise between stations	<ul style="list-style-type: none"> * Results from nature of FM reception * FM Muting Release switch depressed 	<ul style="list-style-type: none"> * Release FM Muting Release switch * Ditto

PROGRAM	SYMPTOM	PROBABLE CAUSE	WHAT TO DO
FM-MPX reception	A. Noise heard during FM-MPX reception but inaudible during FM mono reception	* Weaker signal because service area of FM-MPX broadcast is only half that of FM mono broadcast	<ul style="list-style-type: none"> * Orient antenna for maximum antenna input * Switch on High Filter and/on turn Treble control counterclockwise
	B. Channel separation deteriorates during reception	* Excess heat	* Circulation of room air is important to receiver. Be sure that receiver is well ventilated
	C. Stereo indicator blinks on and off	* Interference	* Indicator is not faulty, adjust VR ₄₀₂
Record playing or tape playback	A. Hum or howling	<ul style="list-style-type: none"> * Turntable placed directly on speaker * Wire other than shielded cable used * Loose terminal contact * Shielded cable too close to power cord, fluorescent lamp or other appliances * Nearby amateur radio station or TV transmission antenna 	<ul style="list-style-type: none"> * Place cushion between turntable and speaker cabinet or place them away from each other * Connecting shielded cables should be as short as possible * Turn on Low Filter and turn Bass control counterclockwise * Consult nearest Radio Regulatory Bureau
	B. Surface noise	<ul style="list-style-type: none"> * Worn or old record * Worn phono stylus * Phono stylus is dusty * Improper stylus pressure 	<ul style="list-style-type: none"> * Recondition playback head of tape deck or the stylus of turntable * Turn Treble control counterclockwise * Turn High Filter on
4-channel stereo playback	A. Position of musical instruments and voice not clear	* Incorrect phasing of speakers or input connections.	<ul style="list-style-type: none"> * Check phasing of speakers and input connections * Change rear speaker position and/or direction

DISASSEMBLY PROCEDURE

REMOVING THE FRONT PANEL, WOOD CASE AND BOTTOM BOARD

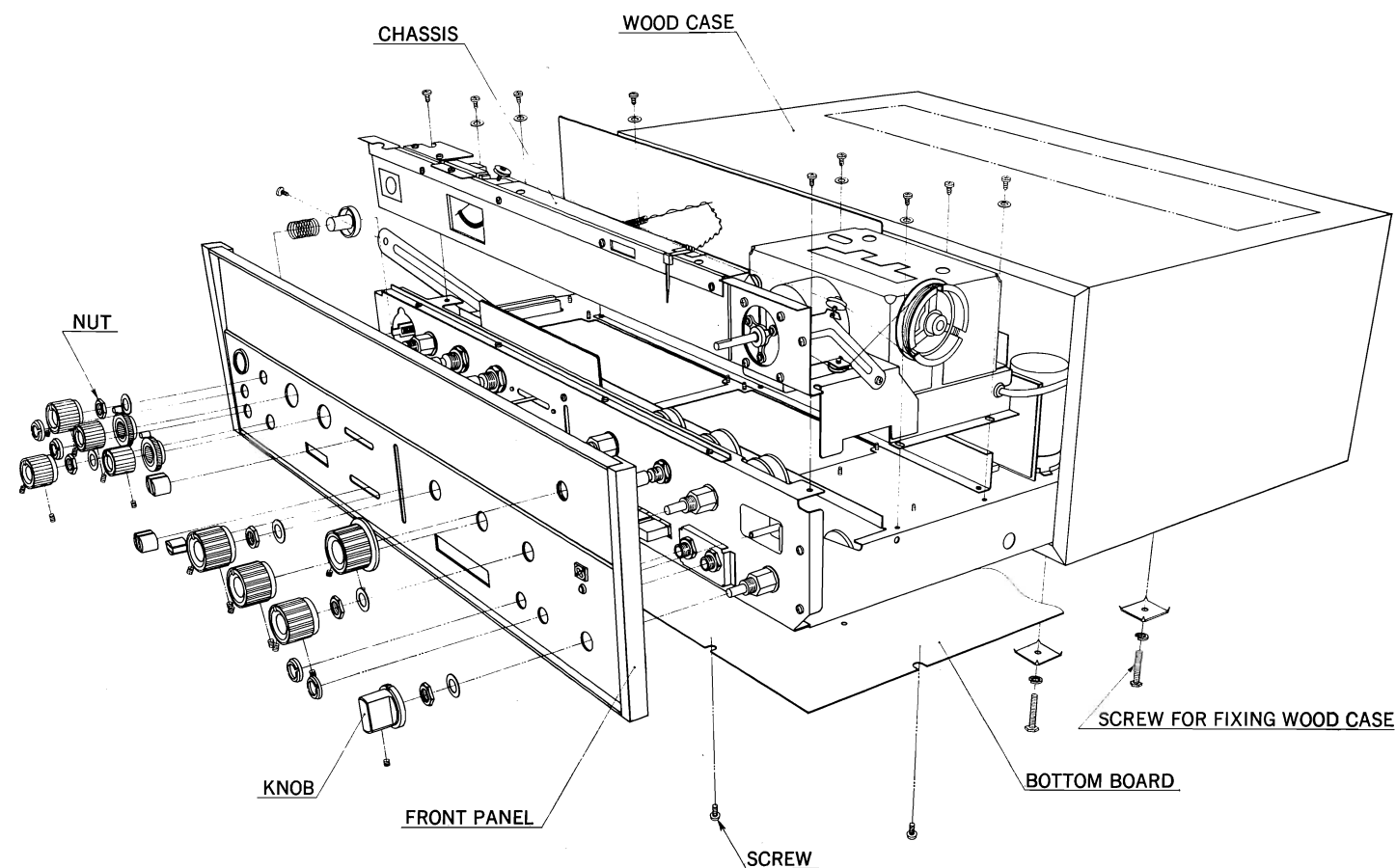

DIAL MECHANISM

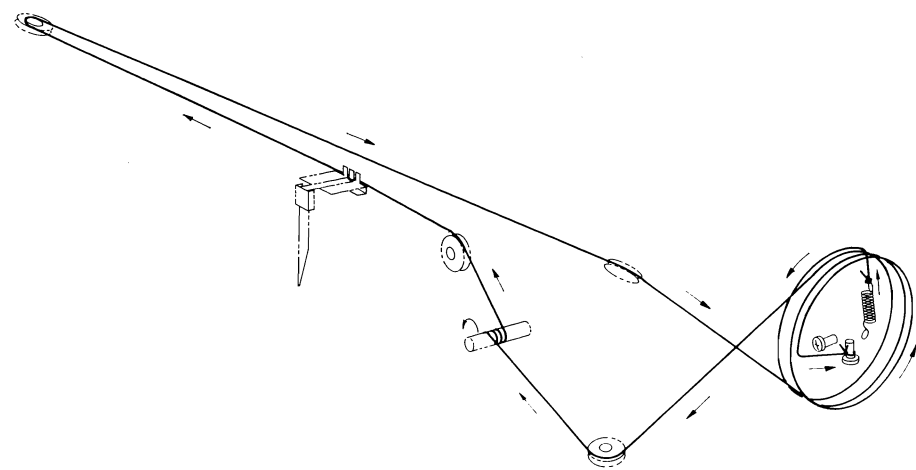

The Tuner Block, if necessary, can be independently separated from the rest of the receiver for examination and servicing purposes. To do so, follow these simple steps:

1. Remove the eleven screws fastening the Tuner Block to the receiver proper.
2. Free the Tuning Control and pull it out. The Tuner Block now floats freely off the receiver proper, but if you need disconnect it completely, move

on to steps 3~5.

3. Unplug the multi-connector (see photo below) very carefully.
4. Pull off the lead wires of the AM ferrite bar antenna. (When you re-assemble, connect the grey wire to F-1038-5 (3A), the black one to F-1038-5 (3B), and the white one to VC₀₀₁).
5. Disconnect, in the middle, the coaxial cable connecting the FM 75Ω terminals to the FM Frontend.

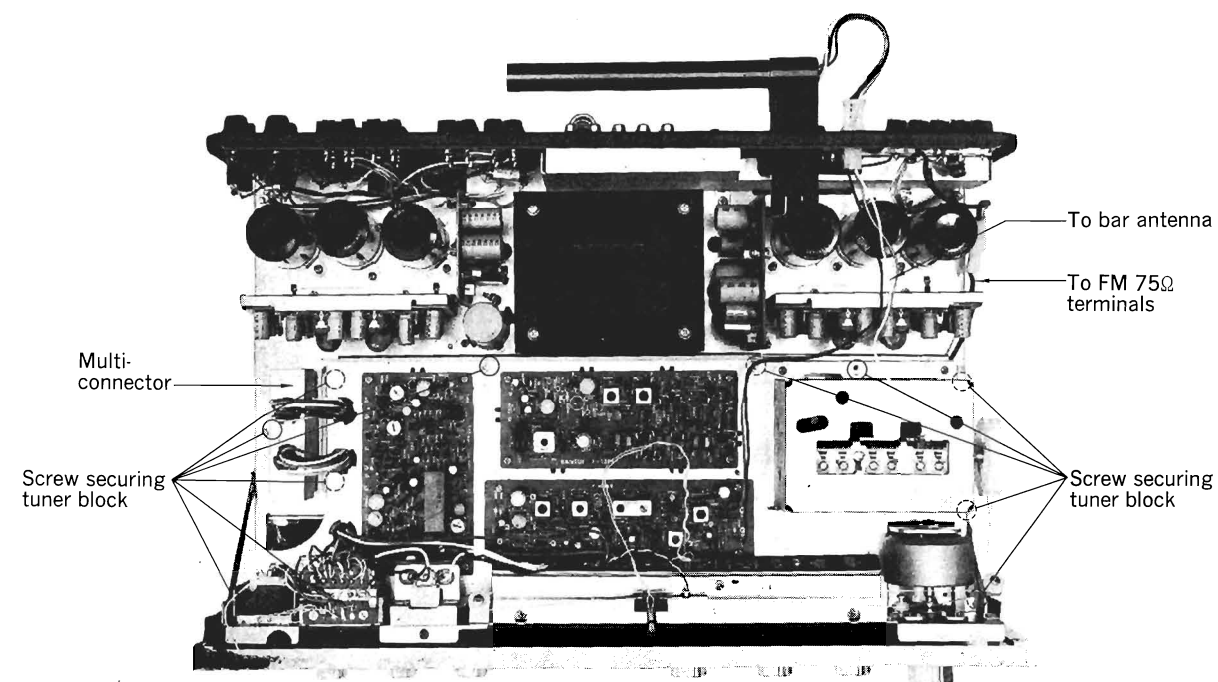

CAUTION

When re-inserting the multi-connector to align the Tuner Block already dismantled or to re-assemble the block itself, be very careful to insert it exactly the same way it was inserted before.

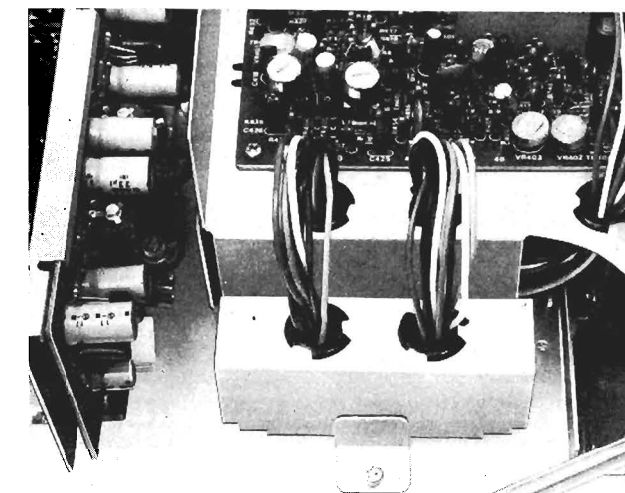

TEST POINTS

SCHEMATIC DIAGRAM OF TUNER SECTION

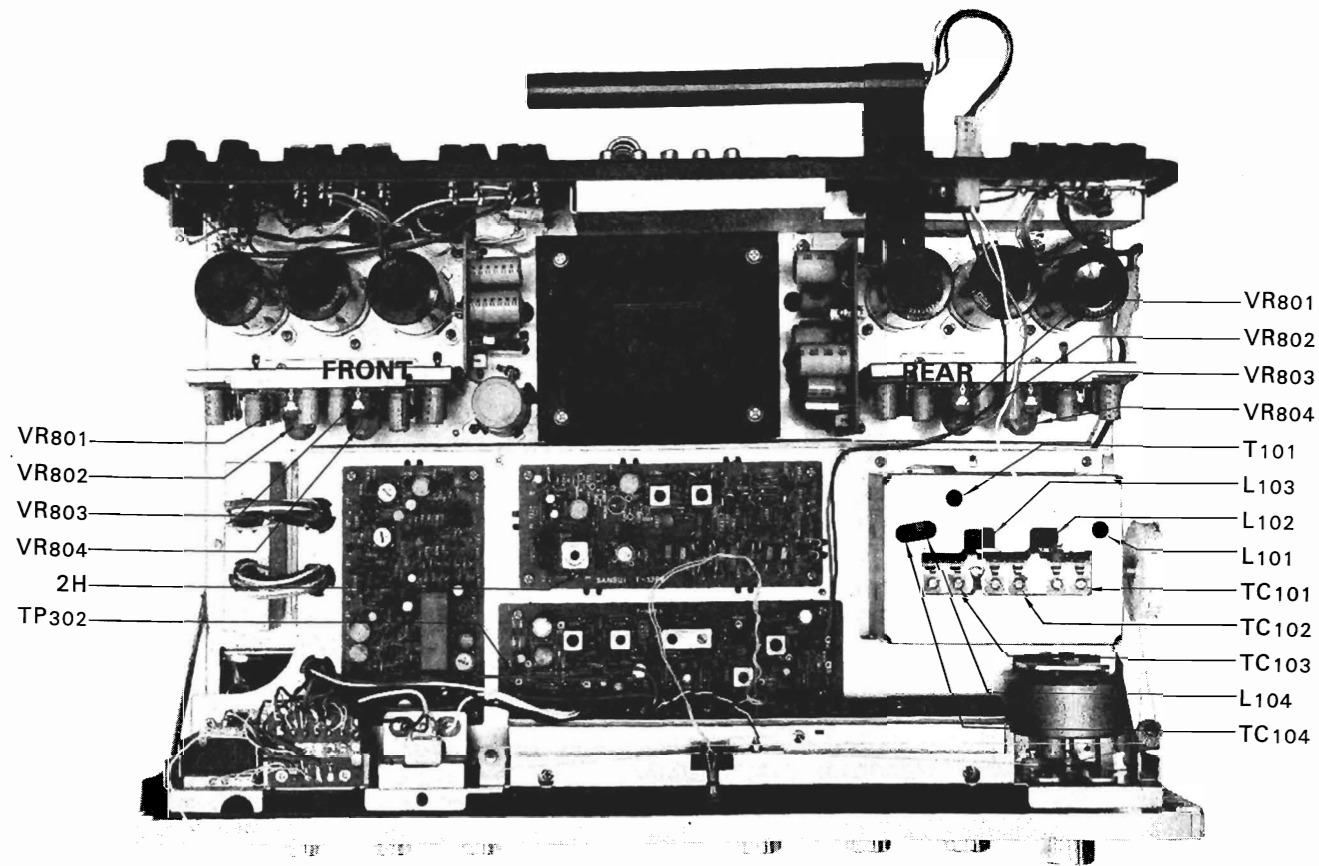

BOTTOM VIEW OF FM FRONTEND

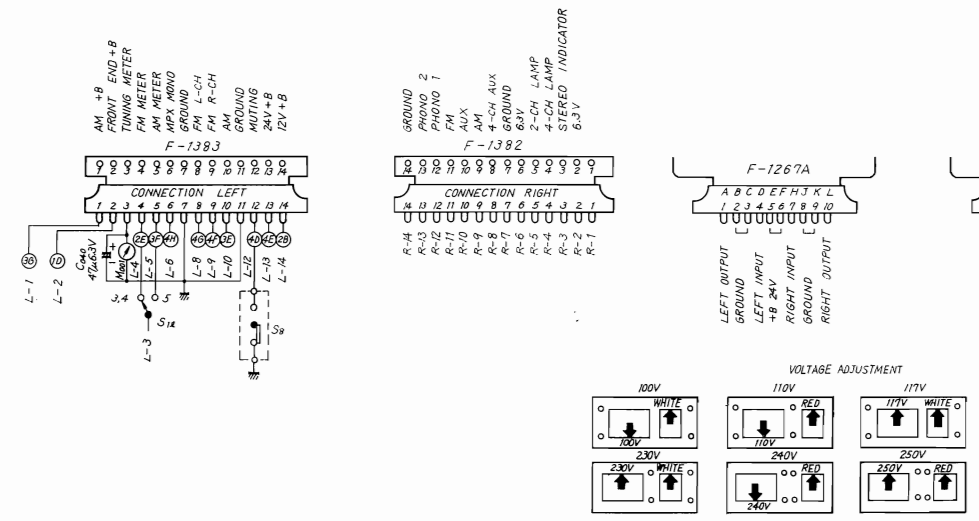
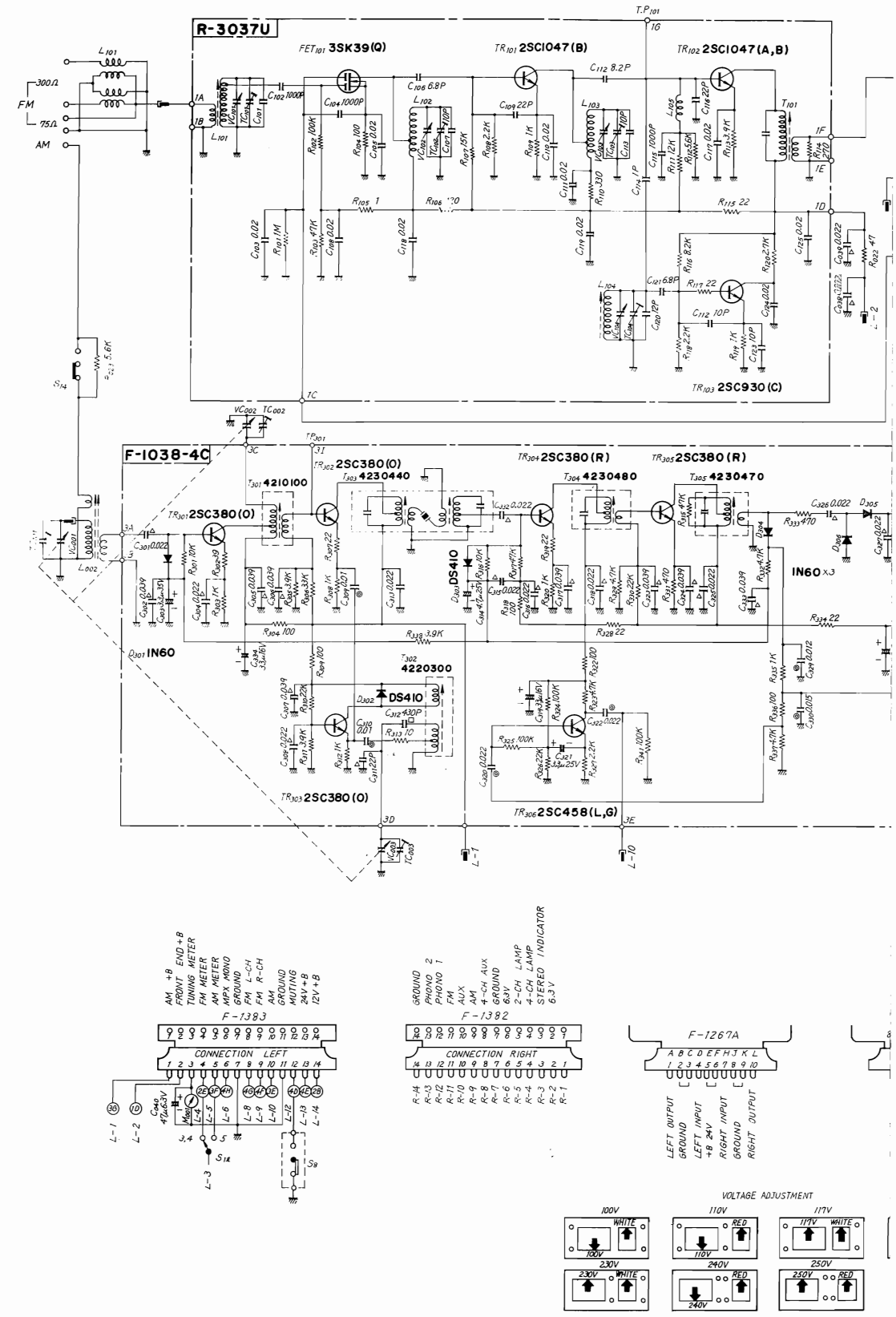
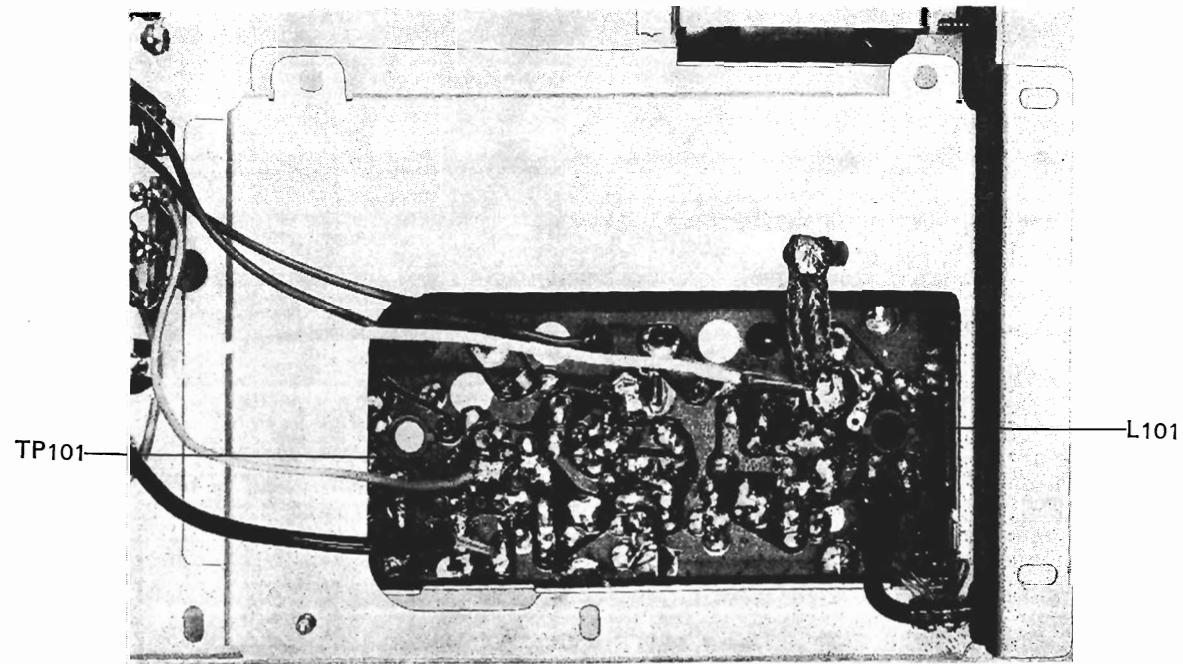

SCHEMATIC DIAGRAM OF AUDIO SECTION

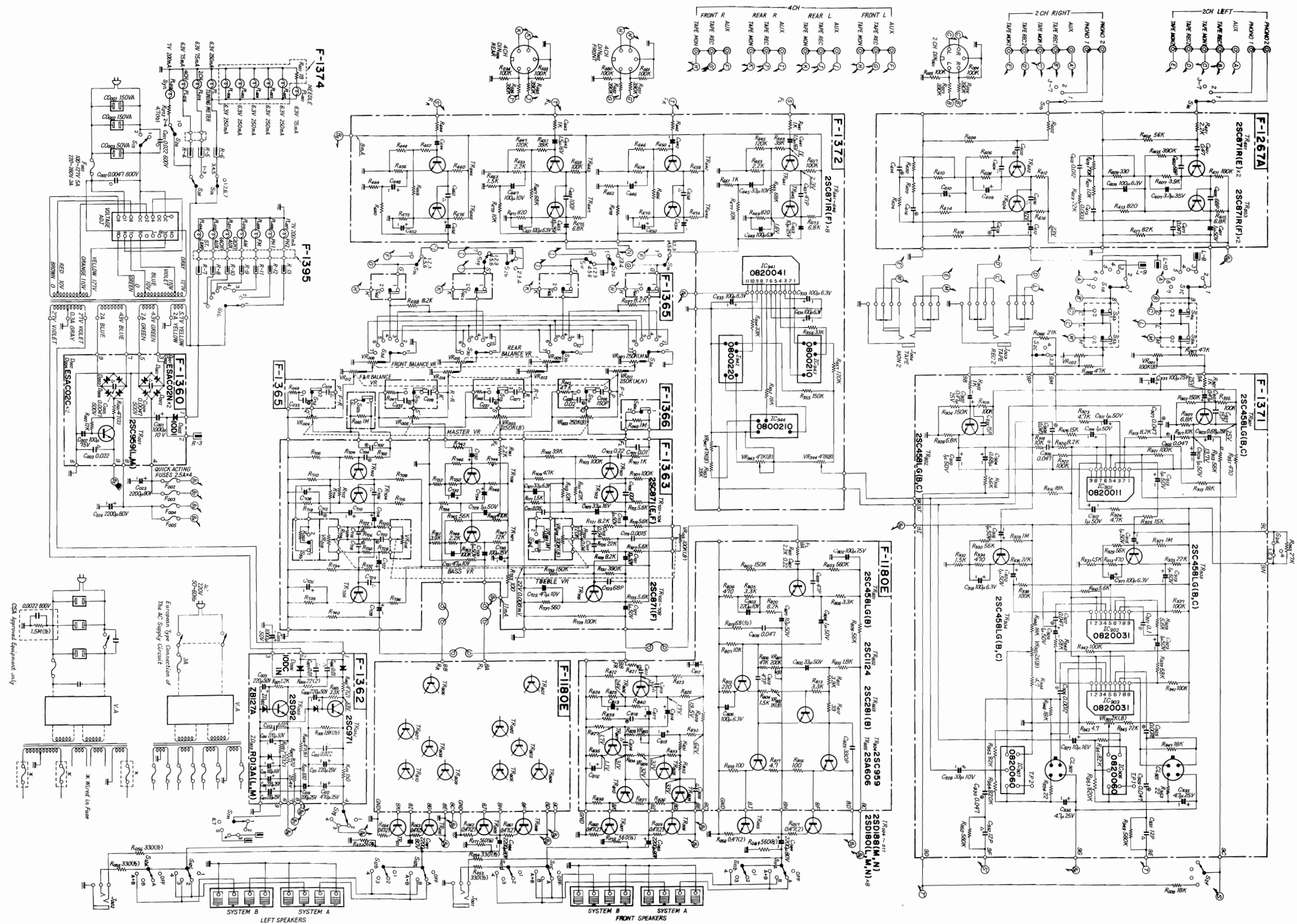

SCHEMATIC DIAGRAM OF TUNER SECTION

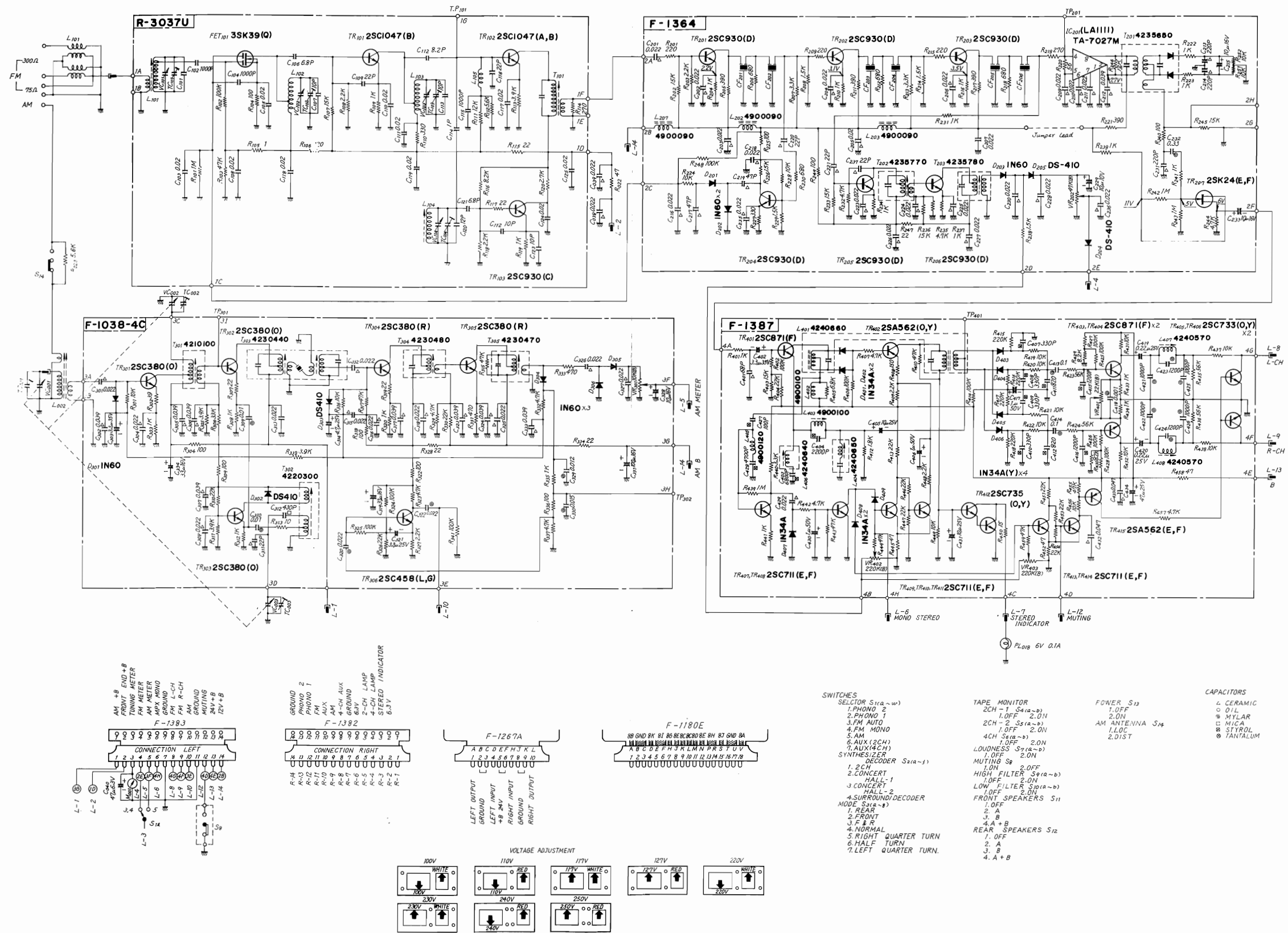

ALIGNMENT

FM ALIGNMENT PROCEDURE

NOTE: Set the FM signal generator level to minimum first.

Any internal parts replacement or changes you make in the QR-4500 requires proper adjustment again. Test points, adjustment procedures and schematic diagrams are given on pages 7~14.
Equipment required: 1. Sweep Generator 2. Oscilloscope 3. FM Signal Generator 4. Multiplex Stereo Generator 5. AC V.T.V.M.

STEP	ALIGN	GENERATOR	FEED SIGNAL	OUTPUT INDICATOR	DIAL SETTING	ADJUST	ADJUST FOR
1.	Discriminator	10.7MHz ±200kHz Sweep generator	To TP ₁₀₁ via the 10pF ceramic capacitor	Oscilloscope is connected to 2H		FM Discriminator transformer T ₂₀₁ primary and secondary	S curve
2.	O.S.C.	FM signal generator 88MHz 400Hz 100% Modulation	To antenna terminals	Oscilloscope and V.T.V.M. at output load	88MHz	O.S.C. coil L ₁₀₄	Maximum
3.	O.S.C.	FM signal generator 108MHz 400Hz 100% Modulation	To antenna terminals	Oscilloscope and V.T.V.M. at output load	108MHz	O.S.C. trimmer TC ₁₀₄	Maximum
4.	Repeat 2 and 3						
5.	RF Amp. Circuit	FM signal generator 90MHz 400Hz 100% Modulation	To antenna terminals	Oscilloscope and V.T.V.M. at output load	90MHz	Antenna coil L ₁₀₁ , L ₁₀₂ and L ₁₀₃	Maximum
6.	RF Amp. Circuit	FM signal generator 106MHz 400Hz 100% Modulation	To antenna terminals	Oscilloscope and V.T.V.M. at output load	106MHz	Trimmer TC ₁₀₁ , TC ₁₀₂ and TC ₁₀₃	Maximum
7.	Repeat 5 and 6						

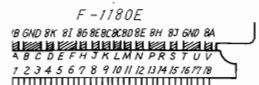
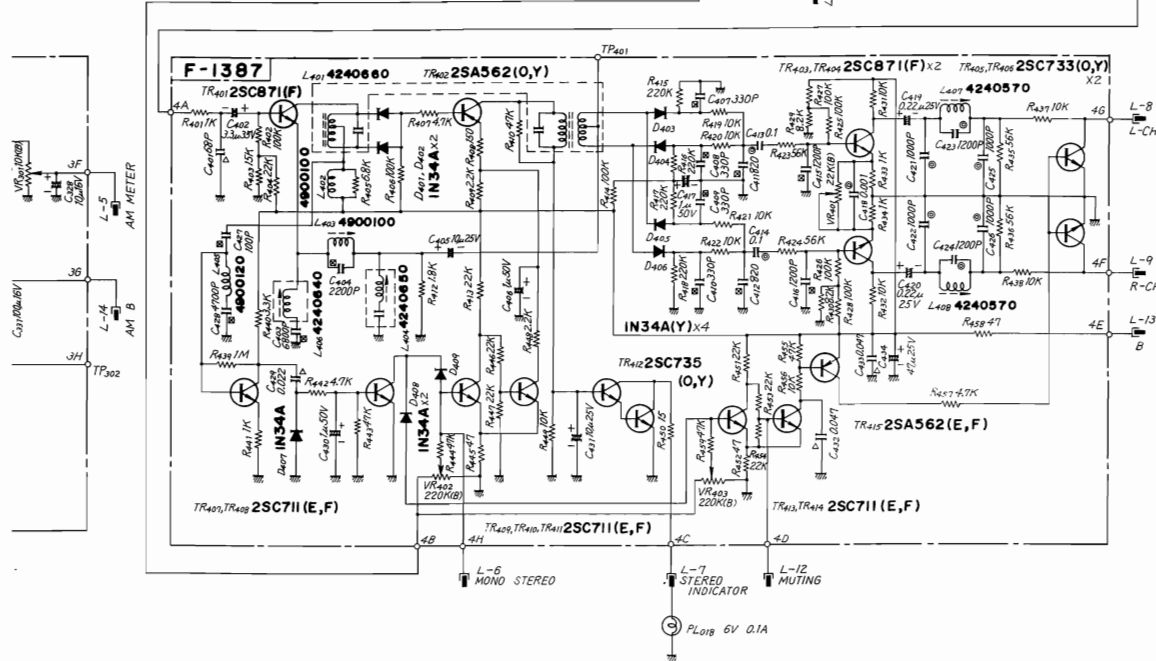
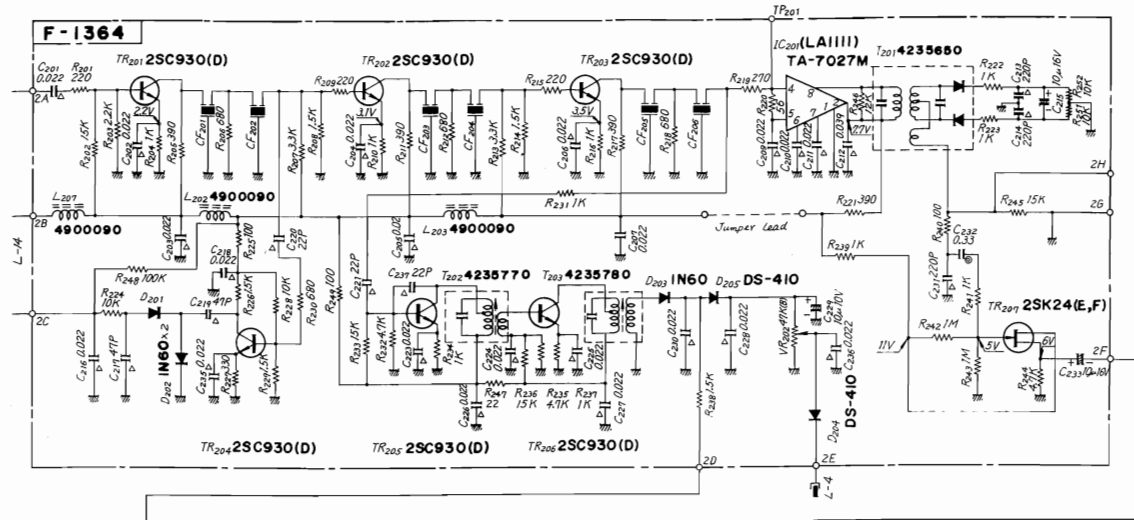

- SWITCHES**
- SELECTOR S_{1(a-w)}
 1. PHONO 2
 2. PHONO 1
 3. FM AUTO
 4. FM MONO
 5. AM
 6. AUX (2CH)
 7. AUX (4CH)
 - SYNTHESIZER DECODER S_{2(a-f)}
 1. 2CH
 2. CONCERT
 3. CONCERT
 4. SURROUND DECODER
 - MODE S_{3(a-b)}
 1. REAR
 2. FRONT
 3. F & R
 4. NORMAL
 5. RIGHT QUARTER TURN
 6. HALF TURN
 7. LEFT QUARTER TURN
- TAPE MONITOR**
- 2CH - 1 S_{4(a-b)}
 1. OFF 2.0N
 - 2CH - 2 S_{5(a-b)}
 1. OFF 2.0N
 - 4CH S_{6(a-b)}
 1. OFF 2.0N
 - LOUDNESS S_{7(a-b)}
 1. OFF 2.0N
 - MUTING S₈
 - 1.0N 2.0OFF
 - HIGH FILTER S_{9(a-b)}
 1. OFF 2.0N
 - LOW FILTER S_{10(a-b)}
 1. OFF 2.0N
 - FRONT SPEAKERS S₁₁
 1. OFF
 2. A
 3. B
 4. A + B
 - REAR SPEAKERS S₁₂
 1. OFF
 2. A
 3. B
 4. A + B
- POWER S₁₂**
- 1. OFF
 - 2.0N
 - AM ANTENNA S₄
 1. LOC
 2. DIST
- CAPACITORS**
- L CERAMIC
 - DIL
 - ⊗ MYLAR
 - MICA
 - ⊗ STYROL
 - ⊗ TANTALUM

FM DISCRIMINATOR WAVE FORM

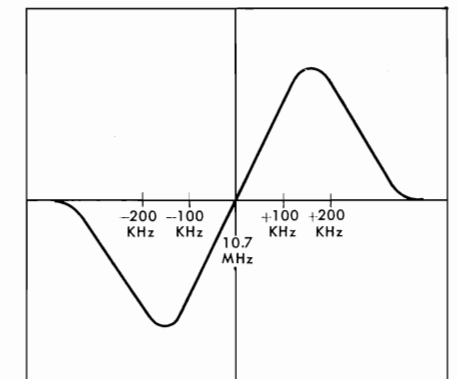

ALIGNMENT

FM MULTIPLEX CIRCUIT

STEP	ALIGN	GENERATOR	FEED SIGNAL	OUTPUT INDICATOR	DIAL SETTING	ADJUST	ADJUST FOR
1.	19kHz phase	FM signal generator—98MHz Stereo signal generator—composite signal with pilot signal, left chan, 30% modulation.	To antenna terminal	Connect distortion meter to right channel load terminal	98MHz	L ₄₀₁	Minimum distortion right chan.
2.	Stereo separation	Same as above	Same as above	Connect oscilloscope and V.T.V.M. to load terminal	Same as above	VR ₄₀₁	Maximum separation

AM ALIGNMENT PROCEDURE

NOTE: To align, set the AM signal generator level to minimum.

STEP	ALIGN	GENERATOR	FEED SIGNAL	OUTPUT INDICATOR	DIAL SETTING	ADJUST	ADJUST FOR
1.	IF Transformer	455kHz \pm 30kHz Sweep-generator	Antenna terminals	Oscilloscope and V.T.V.M. at TP ₃₀₂		I.F.T. T ₃₀₃ ~T ₃₀₅	Best IF wave form
2.	O.S.C.	AM-generator 535kHz 400Hz 30% Modulation	Antenna terminals	Oscilloscope and V.T.V.M. at output load	535kHz	O.S.C. Coil T ₃₀₂	Maximum
3.	O.S.C.	AM-generator 1600kHz 400Hz 30% Modulation	Antenna terminals	Oscilloscope and V.T.V.M. at output load	1600kHz	O.S.C. Trimmer cap. TC ₀₀₃	Maximum
4.	Repeat 2 and 3						
5.	RF amp.	AM-generator 600kHz 400Hz 30% Modulation	Antenna terminals	Oscilloscope and V.T.V.M. at output load	600kHz	RF transformer T ₃₀₁	Maximum
6.	Antenna circuit	AM-generator 600kHz 400Hz 30% Modulation	Antenna terminals	Oscilloscope and V.T.V.M. at output load	600kHz	Ferrite bar Antenna coil L ₀₀₂	Maximum
7.	RF amp.	AM-generator 1400kHz 400Hz 30% Modulation	Antenna terminals	Oscilloscope and V.T.V.M. at output load	1400kHz	RF Trimmer TC ₀₀₂	Maximum
8.	Antenna circuit	AM-generator 1400kHz 400Hz 30% Modulation	Antenna terminals	Oscilloscope and V.T.V.M. at output load	1400kHz	Antenna circuit Trimmer TC ₀₀₁	Maximum
9.	Repeat 5, 6, 7, 8						

AM IF WAVE FORM

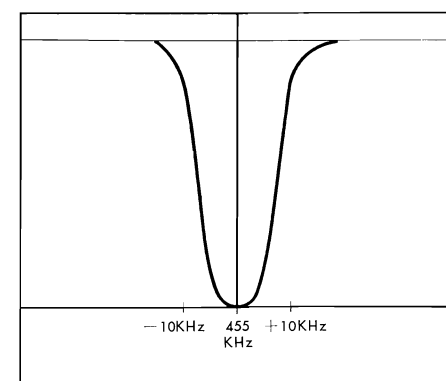

CURRENT ADJUSTMENT

STEP	SETTING OF AMMETER (TESTER)	WHAT TO DO	NOTE
1.		Remove F ₀₀₂ and F ₀₀₃	Use an ammeter with 100mA range
2.		Set VR ₃₀₂ (left and right channel) to minimum	
3.		Set Volume Control to minimum	Be sure to switch on 1st and the connect the ammeter
4.		Turn on the receiver	
5.	100mA range.	Connect ammeter to F ₀₀₂ as illustrated in Fig. 1	
6.		Turn VR ₃₀₂ (left channel) clockwise and adjust current to 30 to 20 mA	
7.	100mA range.	Turn off the receiver and replace F ₀₀₂	
8.		Turn on the receiver and connect ammeter to F ₀₀₃ as illustrated in Fig. 1	
9.		Turn VR ₃₀₃ (right channel) clockwise and adjust current to 30 to 20 mA	
10.		Replace F ₀₀₃	
11.		Adjust the rear channels as above	

OUTPUT ADJUSTMENT

STEP	WHAT TO DO	NOTE
1.	Adjust volume control to minimum	Oscillator used should have oscillation frequency of 20 to 20,000Hz and output voltage of more than 200mV
2.	Set oscillator to 1,000Hz and connect it to 4CH AUX LEFT FRONT input	
3.	Set Selector switch to AUX (4CH)	Set other controls and switches as follows: Balance to CENTER Tape Monitor to OFF Mode to NORMAL Tone to CENTER Other to OFF
4.	Connect 8- or 16-ohm load resistor with capacity of more than 30 watts to LEFT SPEAKER output	
5.	Connect oscilloscope to SPEAKER terminal	
6.	Turn on the receiver and slowly raise volume. Check output at terminal by means of oscilloscope	
7.	Adjust VR ₃₀₁ (left channel) so that peak of sine wave is clipped simultaneously	
8.	Adjust right channel similarly, and then rear channels	

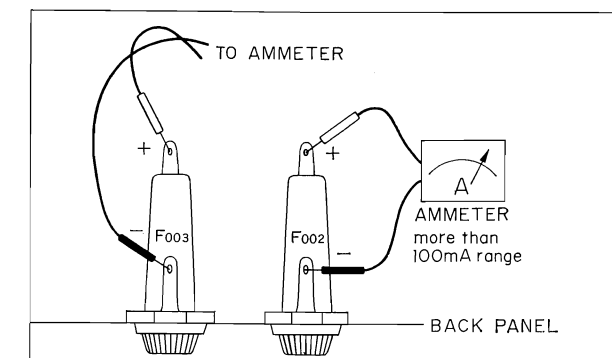

(Fig. 1) QUICK-ACTING FUSE HOLDER

PRINTED CIRCUIT BOARDS AND PARTS LIST

W: Parts No. X: Parts Name Y: Stock No. Z: Position of Parts

FM IF BLOCK <F-1364>

W	X	Y	Z
R201	220Ω	0100221	2C
R202	15kΩ	0100153	2C
R203	2.2kΩ	0100222	2C
R204	1kΩ	0100102	2C
R205	390Ω	0101391	2C
R206	680Ω	0101681	2C
R207	3.3kΩ	0100332	2C
R208	1.5kΩ	0100152	2C
R209	220Ω	0100221	2C
R210	1kΩ	0100102	2C
R211	390Ω	0100391	2C
R212	680Ω	0101681	2C
R213	3.3kΩ	0100332	2C
R214	1.5kΩ	0100152	2C
R215	220Ω	0100221	2B
R216	1kΩ	0100102	2B
R217	390Ω	0100391	2B
R218	680Ω	0101681	2B
R219	270Ω	0101271	2B
R220	56Ω	0100560	2B
R221	390Ω	0101391	2A
R222	1kΩ	0101102	2A
R223	1kΩ	0101102	1A
R224	10kΩ	0100103	1C
R225	100Ω	0101101	1, 2C
R226	1.5kΩ	0101152	1C
R227	330Ω	0100331	1C
R228	10kΩ	0101103	1C
R229	1.5kΩ	0100152	1C
R230	680Ω	0101681	1, 2C
R231	1kΩ	0101102	1, 2C
R232	4.7kΩ	0100472	1C
R233	15kΩ	0100153	1C
R234	1kΩ	0100102	1B
R235	4.7kΩ	0100472	1B
R236	15kΩ	0101153	1B
R237	1kΩ	0100102	1B
R238	1.5kΩ	0100152	1B
R239	1kΩ	0101102	1, 2A
R240	100Ω	0101101	2A
R241	1kΩ	0101102	1A
R242	1MΩ	0100105	1A
R243	1MΩ	0100105	1A
R244	4.7kΩ	0100472	1A
R245	15kΩ	0101153	2A
R246	12kΩ	0101123	2A
R247	22Ω	0101220	1B
R248	100kΩ	0101104	1, 2C
R249	100Ω	0101101	1, 2B
R251	10kΩ	0100103	1A
R252	10kΩ	0100103	1A

W	X	Y	Z
VR202	47kΩ(B)	1035170	1A, B
C201	0.022μF	0656223	1, 2C
C202	0.022μF	0656223	2C
C203	0.022μF	0656223	1C
C204	0.022μF	0656223	2C
C205	0.022μF	0656223	1, 2C
C206	0.022μF	0656223	2B
C207	0.022μF	0656223	2B
C209	0.022μF	0656223	2B
C210	0.022μF	0656223	2B
C211	0.022μF	0656223	2B
C212	0.039μF	0656393	2A
C213	220pF	0660221	2A
C214	220pF	0660221	2A
C215	10μF	0511100	1A
C216	0.022μF	0656223	1C
C217	47pF	0660470	1C
C218	0.022μF	0656223	1C
C219	47pF	0660470	1C
C220	22pF	0660220	2C
C221	22pF	0660220	1C
C223	0.022μF	0656223	1C
C224	0.022μF	0656223	1B
C225	0.022μF	0656223	1B
C226	0.022μF	0656223	1B
C227	0.022μF	0656223	1B
C228	0.022μF	0656223	1B
C229	10μF	0511100	1B
C230	0.022μF	0656223	1B
C231	220pF	0660221	2A
C232	0.33μF	0601338	2A
C233	10μF	0511100	1A
C235	0.022μF	0656223	1A 1C
C236	0.022μF	0656223	1A
C237	2.2pF	0660229	1C
TR201		0305791	2C
TR202		0305791	2C
TR203		0305791	2B
TR204		0305791	1C
TR205		0305791	1C
TR206		0305791	1B
TR207		0370060, 1	1A
IC201	LA1111	0360050	2B
D201		0310330	1C
D202		0310330	1C
D203		0310330	1B
D204	DS-410	0340030	
D205	DS-410	0340030	

W	X	Y	Z
CF201	CFR 10.7M Ceramic Filter	0910101	2C
CF202		0910101	2C
CF203		0910101	2C
CF204		0910101	2C
CF205		0910101	2B
CF206		0910101	2B
T201	Discriminating Transformer	4235650	2A
T202	Meter Coil	4235770	1B
T203		4235780	1B
L201	3.3μH Micro Inductor	4900100	1C
L202		0100102	1, 2C
L203		0100104	2C

Abbreviations

- CR** : Carbon Resistor
- SR** : Solid Resistor
- CeR** : Cement Resistor
- MC** : Mylar Capacitor
- EC** : Electrolytic Capacitor
- AEC** : Aluminum Solid Electrolytic Capacitor
- CC** : Ceramic Capacitor
- MIC** : Mica Capacitor
- SC** : Styrol Capacitor
- TC** : Tantalum Capacitor
- OC** : Oil Capacitor

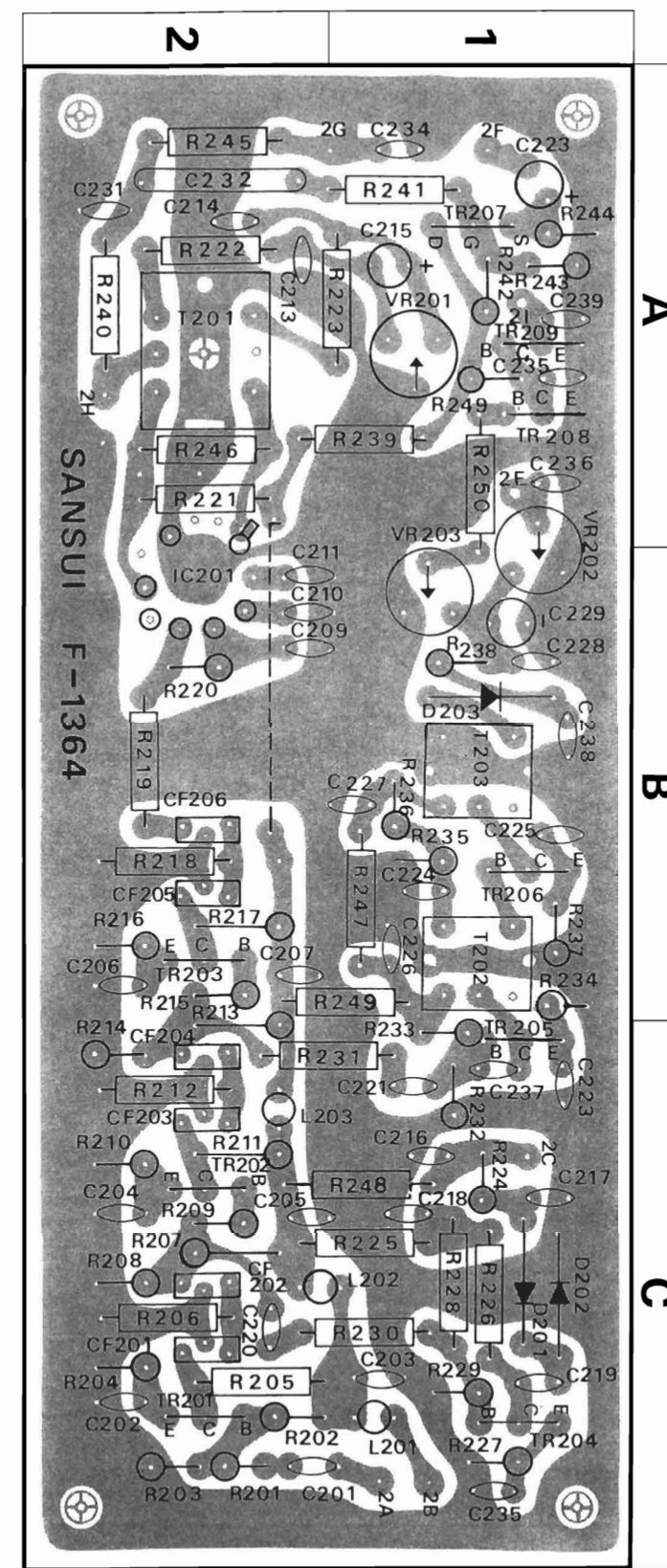

PRINTED CIRCUIT BOARDS AND PARTS LIST

W: Parts No. X: Parts Name Y: Stock No. Z: Position of Parts

FM MPX BLOCK <F-1387>

W	X	Y	Z	
R401	1kΩ	0100102	1 C	
R402	100kΩ	0100104	1 C	
R403	15kΩ	0100153	1 C	
R404	22kΩ	0100223	1 C	
R405	6.8kΩ	0100682	1 C	
R406	100kΩ	0100104	1 B	
R407	4.7kΩ	0100472	2 B	
R408	150Ω	0100151	2 B	
R409	2.2kΩ	0100222	2 B	
R410	47kΩ	0100473	1 B	
R412	1.8kΩ	0100182	1 B	
R413	22kΩ	0100223	2 B	
R414	100kΩ	0100104	2 B	
R415	220kΩ	0100224	1 A, B	
R416	220kΩ	0100224	1 A, B	
R417	220kΩ	0100224	1 A, B	
R418	220kΩ	0100224	1 A	
R419	10kΩ	0100103	1 A	
R420	10kΩ	0100103	1 A	
R421	10kΩ	0100103	1 A	
R422	10kΩ	0100103	1 A	
R423	56kΩ	0100563	1 A	
R424	56kΩ	0100563	1 A	
R425	100kΩ	0100104	1 A	
R426	100kΩ	0100104	1 A	
R427	100kΩ	0100104	1 A	
R428	100kΩ	±10% 1/4W CR.	0100104	1 A
R429	8.2kΩ	0100822	1 A	
R430	8.2kΩ	0100822	1 A	
R431	10kΩ	0100103	1 A	
R432	10kΩ	0100103	2 A	
R433	1kΩ	0100102	2 A	
R434	1kΩ	0100102	1 A	
R435	56kΩ	0100563	2 A	
R436	56kΩ	0100563	2 A	
R437	10kΩ	0100103	2 A	
R438	10kΩ	0109103	2 A	
R439	1MΩ	0100105	2 C	
R440	3.3kΩ	0100332	1, 2 C	
R441	1kΩ	0100102	2 C	
R442	4.7kΩ	0100472	2 C	
R443	47kΩ	0100473	2 C	
R444	47kΩ	0100473	2 B	
R445	47Ω	0100470	2 C	
R446	22kΩ	0100223	2 C	
R447	22kΩ	0100223	2 C	
R448	2.2kΩ	0100222	2 B, C	
R449	10kΩ	0100103	1, 2 B	
R450	15Ω	0100150	2 B	
R451	22kΩ	0100223	2 B	
R452	47Ω	0100470	2 B	

W	X	Y	Z	
R453	22kΩ	0100223	2 B	
R454	22kΩ	0100223	2 B	
R455	47kΩ	0100473	2 B	
R456	10kΩ	±10% 1/4W CR.	0100103	2 B
R457	4.7kΩ	0101472	2 A	
R458	47Ω	0100470	2 B	
R459	47kΩ	0100473	2 B	
VR401	22kΩ (B)	1035150	1 A	
VR402	220kΩ (B)	1035210	2 C	
VR403	220kΩ (B)	1035210	2 B	
C401	68pF ±10% 50 V CC.	0660680	1 C	
C402	3.3μF 25 V EC.	0513339	1 C	
C403	6800pF ±5% 50 V SC.	0629001	1 C	
C404	2200pF ±10% 50 V SC.	0621222	1 B	
C405	10μF 25 V EC.	0513100	1 B	
C406	1μF 50 V EC.	0515109	2 B	
C407	330pF	0612331	1 B	
C408	330pF	0612331	1 B	
C409	330pF ±5% 125V SC.	0612331	1 B	
C410	330pF	0612331	2 B	
C411	820pF	0612821	1 A	
C412	820pF ±5% 125V SC.	0612821	1 A	
C413	0.1μF	0601108	1 A	
C414	0.1μF ±10% 50 V MC.	0601108	1 A	
C415	1200pF	0620122	1 A	
C416	1200pF ±5% 50 V SC.	0620122	1 A	
C417	1μF 50 V EC.	0515109	1, 2 B	
C418	0.001μF ±10% 50 V MC.	0601106	2 A	
C419	0.22μF	0563228	2 A	
C420	0.22μF ±20% 25 V AEC.	0563228	1, 2 A	
C421	0.001μF	0601106	2 A	
C422	0.001μF ±10% 50 V MC.	0601106	1 A	
C423	0.0012μF	0601126	2 A	
C424	0.0012μF ±10% 50 V MC.	0601126	2 A	
C425	0.001μF ±10% 50 V MC.	0601106	2 A	
C426	0.001μF ±10% 50 V MC.	0601106	2 A	
C427	100pF	0621101	1 C	
C428	4700pF ±10% 50 V SC.	0621472	2 C	
C429	0.022μF +80% -20% 25 V CC.	0656223	2 C	
C430	1μF 50 V EC	0515109	2 C	
C431	10μF 25 V EC.	0513100	2 B	
C432	0.047μF	0656473	2 B	
C433	0.047μF +80% -20% 25 V CC.	0656473	2 B	
C434	47μF 25 V EC.	0513470	2 C	
TR401	2SC871 (F)	0305472	1 C	
TR402	2SA562 (O, Y)	0300220, 1	1, 2 B	
TR403		0305472	1 A	
TR404	2SC871 (F)	0305472	1 A	
TR405	2SC733 (O, Y)	0305370, 1	2 A	

W	X	Y	Z
TR406	2SC733 (O, Y)	0305370, 1	2 A
TR407		0305731, 2	2 C
TR408		0305731, 2	2 C
TR409	2SC711 (E, F)	0305731, 2	2 C
TR410		0305731, 2	2 C
TR411		0305731, 2	2 B
TR412	2SC735 (O, Y)	0305640, 1	2 B
TR413		0305731, 2	2 B
TR414	2SC711 (E, F)	0305731, 2	2 B
TR415	2SC562 (O, Y)	0300220, 1	2 B
D401	IN34A	0310400	1 C
D402		0310400	2 B, C
D403		0310401	1 B
D404	IN34A (Y)	0310401	1 B
D405		0310401	1 B
D406		0310401	1 B
D407		0310400	2 C
D408	IN34A	0310400	2 C
D409		0310400	2 C
L401	MPX Coil	4240660	1 B, C

W	X	Y	Z
L402	2.2mH Micro Inductor	4900100	1 C
L403		4900100	1 B
L404	MPX Coil	4240650	1 B
L405	1mH Micro Inductor	4900120	2 C
L406		4240640	1 C
L407	MPX Coil	4240570	2 A
L408		4240570	2 A

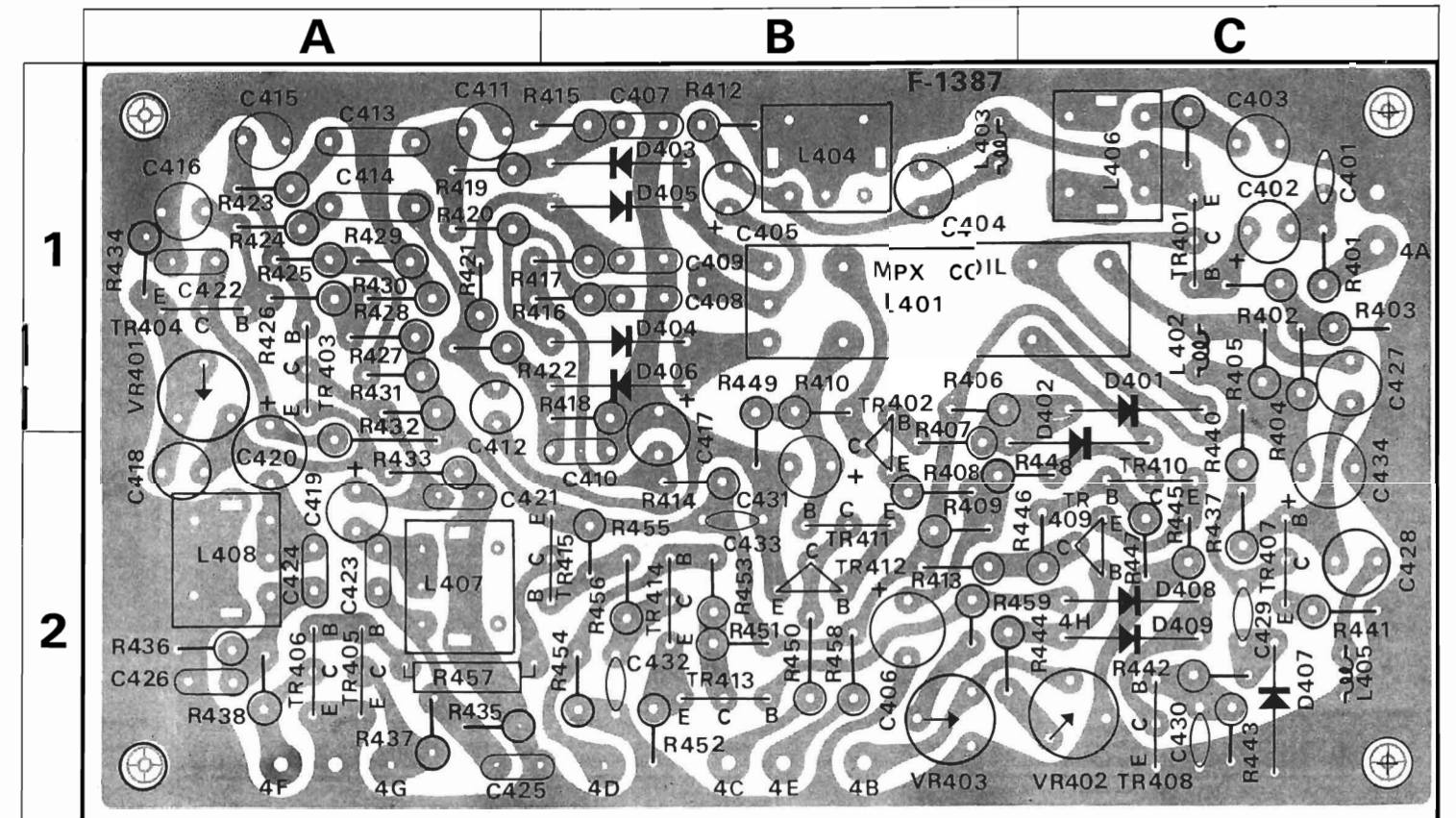

PRINTED CIRCUIT BOARDS AND PARTS LIST

W: Parts No. X: Parts Name Y: Stock No. Z: Position of Parts

AM BLOCK <F-1038-4C>

W	X	Y	Z
R301	10kΩ	0101103	1, 2C
R302	39Ω	0101390	1C
R303	1kΩ	0101102	2C
R304	100Ω	0101101	1C
R305	3.9kΩ	0101392	2C
R306	33kΩ	0101333	1C
R307	22Ω	0101220	1, 2B
R308	1kΩ	0101102	2B
R309	100Ω	0101101	1C
R310	22kΩ	0101223	2B, C
R311	3.9kΩ	0101392	1B
R312	1kΩ	0101102	2B
R313	10Ω	0101100	2B, C
R314	22Ω	0101220	1B
R315	47kΩ	0101473	1A
R316	10kΩ	0101103	2B
R317	47kΩ	0101473	1B
R318	100Ω	0101101	2B
R319	22Ω	0101220	2B
R320	1kΩ	0101102	1B
R322	100Ω	0101101	1B
R323	4.7kΩ	0101472	2B
R324	100kΩ	0101104	2A, B
R325	100kΩ	0101104	2A, B
R326	22kΩ	0101223	2A
R327	2.2kΩ	0101222	2B
R328	22Ω	0101220	1A, B
R329	4.7kΩ	0101472	1A, B
R330	22kΩ	0101223	1A
R331	470Ω	0101471	1A
R332	4.7kΩ	0101472	2A
R333	470Ω	0101471	1A
R334	22Ω	0101220	1A
R335	1kΩ	0101102	2A
R336	100Ω	0101101	2A
R337	4.7kΩ	0101472	2A
R338	3.9kΩ	0101392	2A
R341	100kΩ	0101104	
VR301	10kΩ (B) AM Meter Adj.	1035130	1, 2A
C301	0.022μF } +80% 25 V CC.	0656223	1C
C302	0.039μF } -20%	0656393	2C
C303	3.3μF } 25 V EC.	0513339	2C
C304	0.022μF } +80% 25 V CC.	0656223	2C
C305	0.039μF } -20%	0656393	1C
C306	0.039μF } +80% 25 V CC.	0656393	2C
C307	0.039μF } -20%	0656393	1C
C308	0.022μF } +80% 25 V CC.	0656223	1B
C309	0.01μF } ±10% 50 V MC.	0601107	2B
C310	0.01μF } ±10% 50 V MC.	0601107	2B
C311	22pF } ±10% 50 V CC.	0660220	2C
C312	430pF } ±5% 50 V MiC.	0640431	2C

W	X	Y	Z
C313	0.022μF } +80% 25 V CC.	0656223	1C
C314	4.7μF } 16 V EC.	0512479	2B
C315	0.022μF } +80% 25 V CC.	0656223	2B
C316	0.022μF } -20%	0656223	1B
C317	0.039μF } +80% 25 V CC.	0656393	2B
C318	0.022μF } -20%	0656223	1B
C319	33μF } 16 V EC.	0512330	2B
C320	0.022μF } ±10% 50 V MC.	0601227	2A
C321	3.3μF } 25 V EC.	0513339	2B
C322	0.022μF } ±10% 50 V MC.	0601227	2A
C323	0.039μF } +80% 25 V CC.	0656393	2B
C324	0.039μF } -20%	0656393	2A
C325	0.022μF } +80% 25 V CC.	0656223	1A
C326	0.022μF } -20%	0656223	1A
C327	0.022μF } +80% 25 V CC.	0656223	1A
C328	10μF } 16 V EC.	0512100	2A
C329	0.012μF } ±10% 50 V MC.	0601127	2A
C330	0.015μF } ±10% 50 V MC.	0601157	2A
C331	100μF } 16 V EC.	0512101	1A
C332	0.022μF } +80% 25 V CC.	0656223	1B
C333	0.039μF } -20%	0656393	2A
C334	33μF } 16 V EC.	0512330	1C
TR301	} 2SC380 (O)	0305331	1C
TR302		0305331	1C
TR303		0305331	2B
TR304	} 2SC380 (R)	0305330	1, 2B
TR305		0305330	1A
TR306	} 2SC458LG (C)	0305320	2A
D301	IN60	0310330	1, 2C
D303	DS-410	0340030	1C
D303		0340030	2B
D304		0310330	1, 2A
D305	IN60	0310330	1A
D306		0310330	1A
T301	AM RFT	4210100	1C
T302	AM OSC Coil	4220300	2C
T303	Ceramic Filter	4230440	1B
T304		4230480	1B
T305	AM IFT 455kHz	4230470	1A

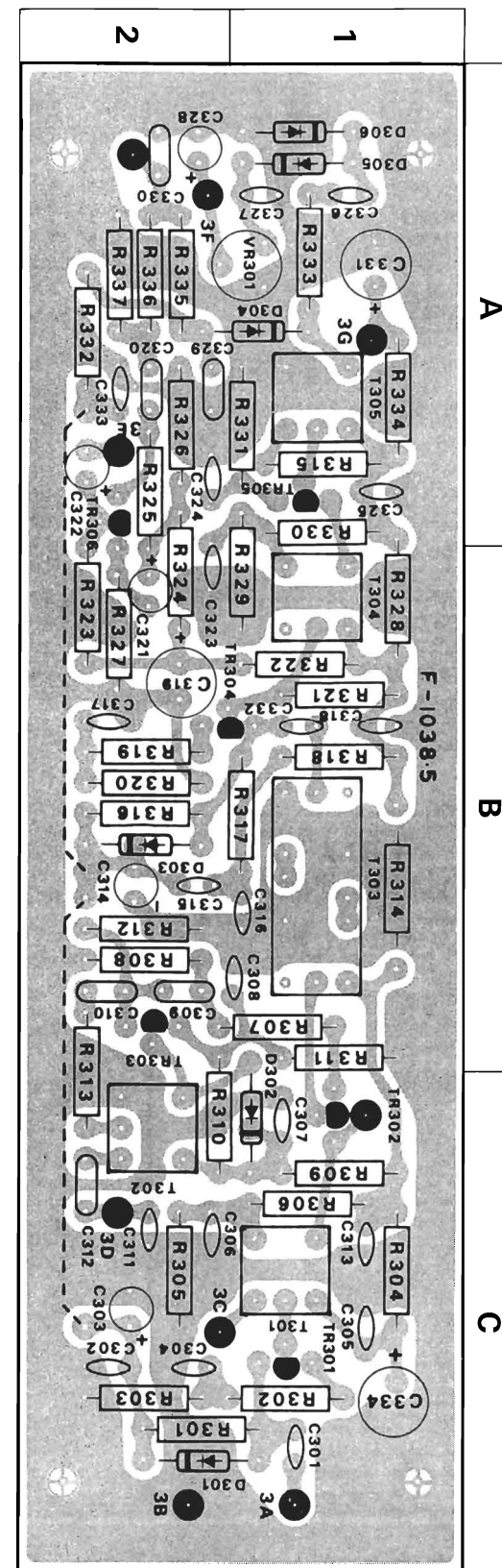

SWITCH BLOCK <F-1365>

W	X	Y
R045	33kΩ	0101333
R046	33kΩ	0101333
R047	33kΩ	0101333
R048	33kΩ	0101333
	±10% 1/4W CR.	
C026	150pF	0660151
C027	150pF	0660151
C028	150pF	0660151
C029	150pF	0660151
C030	0.02μF	0601207
C031	0.02μF	0601207
C032	0.02μF	0601207
C033	0.02μF	0601207
	±10% 50 V MC.	
S4(a,b)	2CH-1 Tape Monitor Switch	113042
S5(a,b)	2CH-2 Tape Monitor Switch	
S6(a~d)	4-Channel Tape Monitor Switch	
S7(a~d)	Loudness Switch	
S8	FM Muting Release Switch	

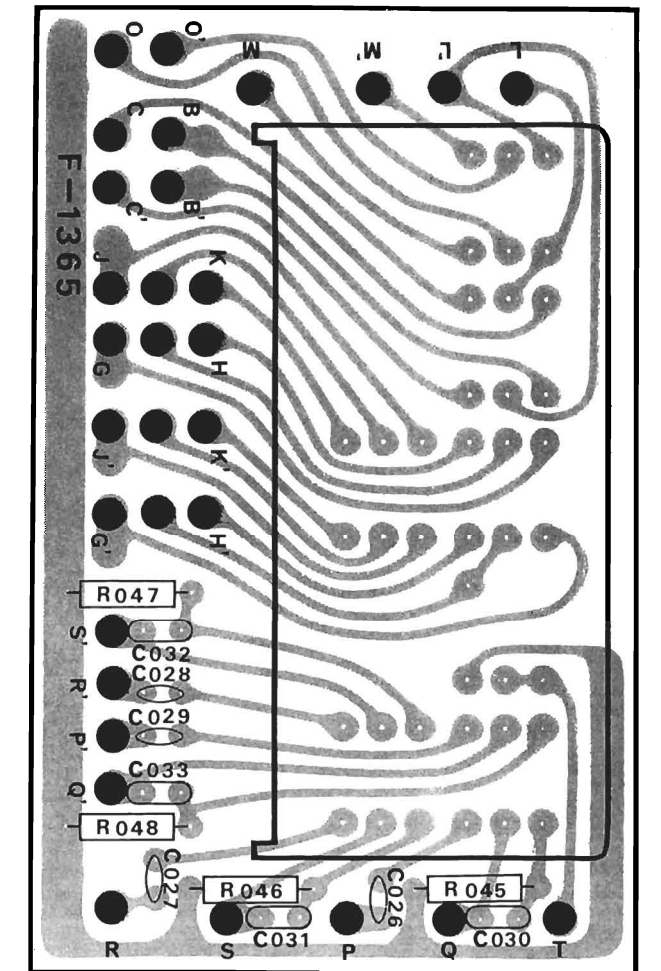

PRINTED CIRCUIT BOARDS AND PARTS LIST

W: Parts No. X: Parts Name Y: Stock No. Z: Position of Parts

EQUALIZER BLOCK <F-1267A>

W	X	Y	Z
R601	2.2k Ω	0101222	2 B
R602	2.2k Ω	0101222	2 A
R603	56k Ω	0101563	2 B
R604	56k Ω	0101563	2 A
R605	390k Ω	0101394	2 B
R606	390k Ω	0101394	2 A
R607	3.9k Ω	0101392	2 B
R608	3.9k Ω	0101392	2 A
R609	330 Ω	0101331	1 B
R610	330 Ω	0101331	1 A
R611	180k Ω	0101184	1 B
R612	180k Ω	0101184	1 A
R613	820 Ω	0101821	1 B
R614	820 Ω	0101821	1 A
R615	6.8k Ω	0101682	1 B
R616	6.8k Ω	0101682	1 A
R617	82k Ω	0101823	2 B
R618	82k Ω	0101823	2 A
R619	270k Ω	0101274	1 B
R620	270k Ω	0101274	1 A
R621	1k Ω	0101102	1 B
R622	1k Ω	0101102	1 A
R623	22k Ω	0101223	1 B
R624	22k Ω	0101223	1 A

W	X	Y	Z
C601	0.47 μ F	0601478	2 B
C602	0.47 μ F	0601478	2 A
C603	68 pF	0660680	2 B
C604	68 pF	0660680	2 A
C605	68 pF	0660680	1 B
C606	68 pF	0660680	1 A
C607	3.3 μ F	0513339	2 B
C608	3.3 μ F	0513339	2 A
C609	100 μ F	0510101	2 B
C610	100 μ F	0510101	2 A
C611	1 μ F	0515109	1 B
C612	1 μ F	0515109	1 A
C613	0.012 μ F	0601127	1 B
C614	0.012 μ F	0601127	1 A
C615	0.003 μ F	0601306	1 B
C616	0.003 μ F	0601306	1 A
C617	0.047 μ F	0601477	1 B
C618	0.047 μ F	0601477	1 A
TR601	2SC871R (E)	0305474	2 B
TR602	2SC871R (E)	0305474	2 A
TR603	2SC871R (F)	0305475	2 B
TR604	2SC871R (F)	0305475	2 A

SYNTHESIZER BLOCK <F-1371>

W	X	Y	Z
R901	1k Ω	0101102	2 C
R902	1k Ω	0101102	1 C
R903	150k Ω	0101154	2 C
R904	150k Ω	0101154	1 C
R905	100k Ω	0101104	2 C
R906	100k Ω	0101104	1 C
R907	6.8k Ω	0101682	2 C
R908	6.8k Ω	0101682	1 C
R909	5.6k Ω	0101562	1 B
R910	5.6k Ω	0101562	2 B
R913	56k Ω	0101563	2 C
R914	56k Ω	0101563	1 C
R915	18k Ω	0101183	2 C
R916	18k Ω	0101183	1 C
R917	10k Ω	0101103	2 C
R918	10k Ω	0101103	1 C
R919	8.2k Ω	0101822	2 C
R920	8.2k Ω	0101822	1 C
R921	100k Ω	0101104	2 C
R922	100k Ω	0101104	1 C
R923	4.7k Ω	0101472	2 C
R924	4.7k Ω	0101472	1 C
R925	15k Ω	0101153	1, 2 C
R926	15k Ω	0101153	1, 2 C
R927	1M Ω	0101105	1 B
R928	1M Ω	0101105	2 B
R929	56k Ω	0101563	1 B
R930	56k Ω	0101563	2 B

W	X	Y	Z
R931	1.5k Ω	0101152	1 B, C
R932	1.5k Ω	0101152	2 B, C
R933	470 Ω	0101471	1 B
R934	470 Ω	0101471	2 B
R935	22k Ω	0101223	1 B
R936	22k Ω	0101223	2 B
R937	100k Ω	0101104	1 B
R938	100k Ω	0101104	2 B
R939	68k Ω	0101683	1 B
R940	68k Ω	0101683	2 B
R941	100k Ω	0101104	1 B
R942	100k Ω	0101104	2 B
R943	4.7 Ω	0101479	1 B
R944	4.7 Ω	0101479	2 B
R945	22k Ω	0101223	1 B
R946	18k Ω	0101183	2 B
R947	18k Ω	0101183	1 A
R948	18k Ω	0101183	2 A
R949	560k Ω	0101564	1 A
R950	560k Ω	0101564	2 A
R951	470 Ω	0101471	1 C
R953	22 Ω	0101220	1 A
R954	22 Ω	0101220	2 A
R961	82k Ω	0101823	
R962	82k Ω	0101823	
R963	820k Ω	0101824	
R964	820k Ω	0101824	
VR901	2k Ω (B)	1032070	1 B
VR902	2k Ω (B)	1032070	2 B

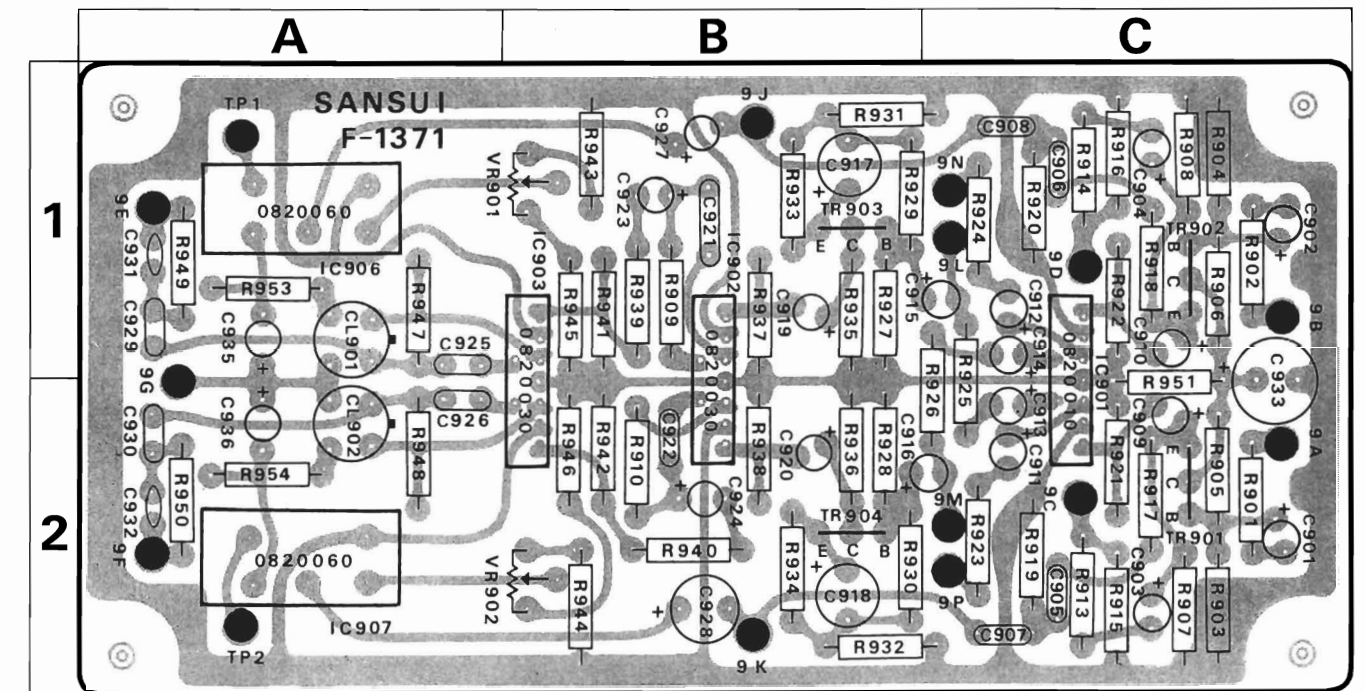
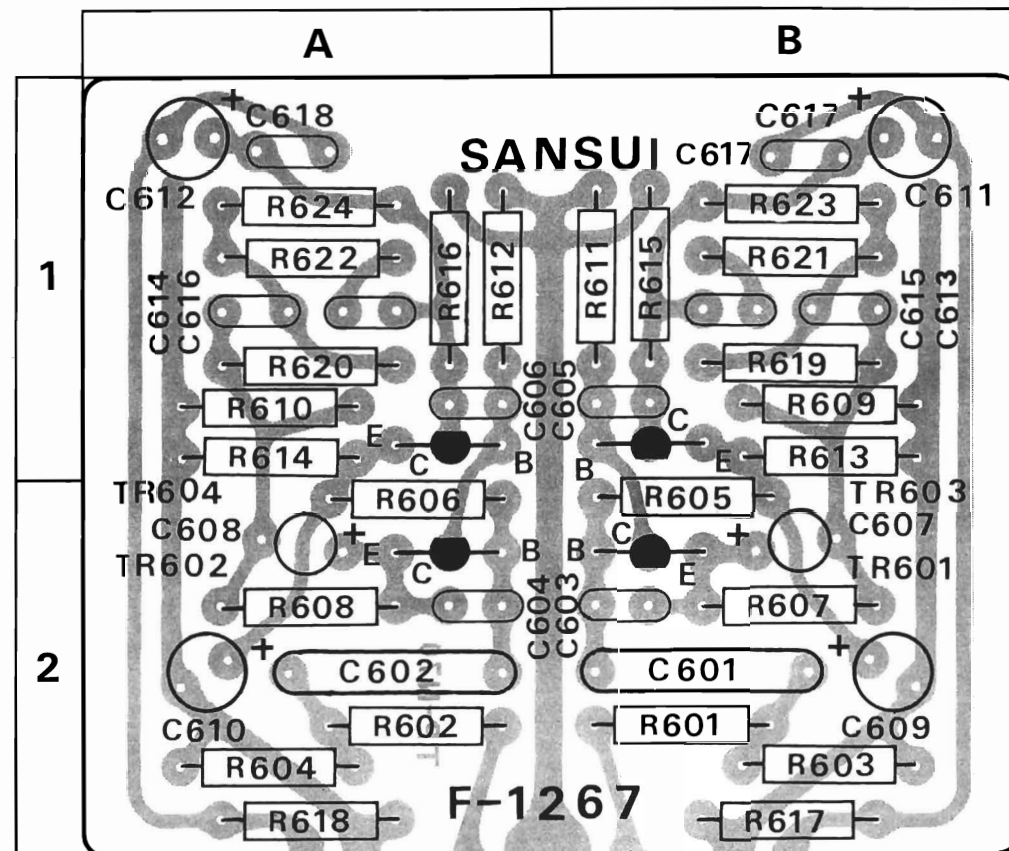

PRINTED CIRCUIT BOARDS AND PARTS LIST

W: Parts No. X: Parts Name Y: Stock No. Z: Position of Parts

SYNTHESIZER BLOCK <F-1371> cont'd

W	X	Y	Z
C901	0.47 μ F } $\pm 20\%$ 25 V AEC.	0563478	2C
C902	0.47 μ F }	0563478	1C
C903	0.68 μ F } $\pm 20\%$ 25 V AEC.	0563688	2C
C704	0.68 μ F }	0563368	1C
C905	0.047 μ F }	0601477	2C
C906	0.047 μ F }	0601477	1C
C907	0.047 μ F } $\pm 10\%$ 50 V MC.	0601477	2C
C908	0.047 μ F }	0601477	1C
C909	1 μ F }	0515109	2C
C910	1 μ F }	0515109	1C
C911	1 μ F }	0515109	2C
C912	1 μ F }	0515109	1C
C913	1 μ F }	0515109	2C
C914	1 μ F }	0515109	1C
C915	1 μ F }	0515109	1C
C916	1 μ F }	0515109	2B, C
C917	100 μ F }	0510101	1B
C918	100 μ F }	0510101	2B
C919	1 μ F }	0515109	1B
C920	1 μ F }	0515109	2B
C921	0.1 μ F }	0601108	1B
C922	0.047 μ F } $\pm 10\%$ 50 V MC.	0601477	2B
C923	1 μ F }	0515109	1B
C924	1 μ F }	0515109	2B
C925	0.0018 μ F }	0601186	1A
C926	0.0012 μ F } $\pm 10\%$ 50 V MC.	0601126	2A
C927	10 μ F }	0511100	1B
C928	33 μ F }	0511330	2B
C929	0.047 μ F }	0601477	1A
C930	0.047 μ F }	0601477	2A
C931	12 pF }	0660120	1A
C932	12 pF } $\pm 10\%$ 50 V CC.	0660120	2A
C933	100 μ F }	0513101	1, 2C
C935	4.7 μ F }	0513472	1A
C936	4.7 μ F }	0513472	2A
C937	15 pF }	0660150	
C938	15 pF } $\pm 10\%$ 50 V CC.	0660150	
TR901		0305313, 4	2C
TR902	2SC458LG (B, C)	0305313, 4	1C
TR903		0305313, 4	1B
TR904		0305313, 4	2B
IC901			0820010
IC902	Hybrid IC	0820030	1, 2B
IC903		0820030	1, 2B
IC906		0820060	1A
IC907		0820060	2A
CL901		MCL-706	0920021
CL902	0920021		2A

PHASE MODULATOR BLOCK <F-1372>

W	X	Y	Z
R641	1k Ω	0101102	1A
R642	1k Ω	0101102	1B
R643	1k Ω	0101102	1, 2A
R644	1k Ω	0101102	1, 2B
R645	120k Ω	0101124	1A
R646	120k Ω	0101124	1B
R647	120k Ω	0101124	2A
R648	120k Ω	0101124	2B
R649	39k Ω	0101393	1A
R650	39k Ω	0101393	1B
R651	39k Ω	0101393	2A
R652	39k Ω	0101393	2B
R653	2.2k Ω	0101222	1A
R654	2.2k Ω	0101222	1B
R655	2.2k Ω	0101222	2A
R656	2.2k Ω	0101222	2B
R657	100k Ω	0101104	1A
R658	100k Ω	0101104	1B
R659	100k Ω	0101104	1A
R660	100k Ω	0101104	1, 2B
R661	1k Ω	0101102	1A
R662	1k Ω	0101102	1B, 2B
R663	1.5k Ω	0101152	2A
R664	1.5k Ω	0101152	2B
R665	68k Ω	0101683	1A
R666	68k Ω	0101683	1B
R667	68k Ω	0101683	2A
R668	68k Ω	0101683	2B
R669	820 Ω	0101821	1A
R670	820 Ω	0101821	1B
R671	820 Ω	0101821	2A
R672	820 Ω	0101821	2B
R673	6.8k Ω	0101682	1A
R674	6.8k Ω	0101682	1B
R675	6.8k Ω	0101682	1A
R676	6.8k Ω	0101682	1B
R677	10k Ω	0101103	1A
R678	10k Ω	0101103	1B
R679	10k Ω	0101103	2A
R680	10k Ω	0101103	2B
R952	18k Ω	0101183	1C
R953	39k Ω	0101393	1C
R954	33k Ω	0101333	1C
R955	150k Ω	0101154	1C
R956	33k Ω	0101333	1C
R957	120k Ω	0101124	1C
VR941	47k Ω (B)	1035170	1C
VR942	47k Ω (B)	1035170	
VR943	47k Ω (B)	1035170	1C
C641	1.5 μ F }	0579003	1A
C642	1.5 μ F }	0579003	1B
C643	1.5 μ F }	0579003	1A
C644	1.5 μ F }	0579003	1B
C645	33 μ F }	0510330	1A
C646	33 μ F }	0510330	1B

$\pm 10\%$ $\frac{1}{4}$ W CR.

15 V TC.

6.3 V EC.

W	X	Y	Z
C647	100 μ F }	0510101	2A
C648	100 μ F }	0510101	2B
C649	100 μ F }	0510101	1A
C650	100 μ F }	0510101	1B
C651	100 μ F }	0510101	2A
C652	100 μ F }	0510101	2B
C653	10 μ F }	0513100	1A
C654	10 μ F }	0513100	1B
C655	10 μ F }	0513100	2A
C656	10 μ F }	0513100	1B
C657	47 pF }	0660470	1A
C658	47 pF }	0660470	1B
C659	100 pF }	0660101	2A
C660	100 pF }	0660101	2B
C933	100 μ F }	0510101	1C
C934	100 μ F }	0510101	1C
C935	100 μ F }	0510101	1C
TR641		0305475	1A
TR642		0305475	1B
TR643		0305475	1, 2A
TR644		0305475	1, 2B
TR645		0305475	1A
TR646		0305475	1B
TR647		0305475	2A
TR648		0305475	2B

2SC871R (F)

W	X	Y	Z
IC941	Hybrid IC	0820040	1C
IC942		0800220	1, 2C
IC943		0800210	2C
IC944		0800210	2C

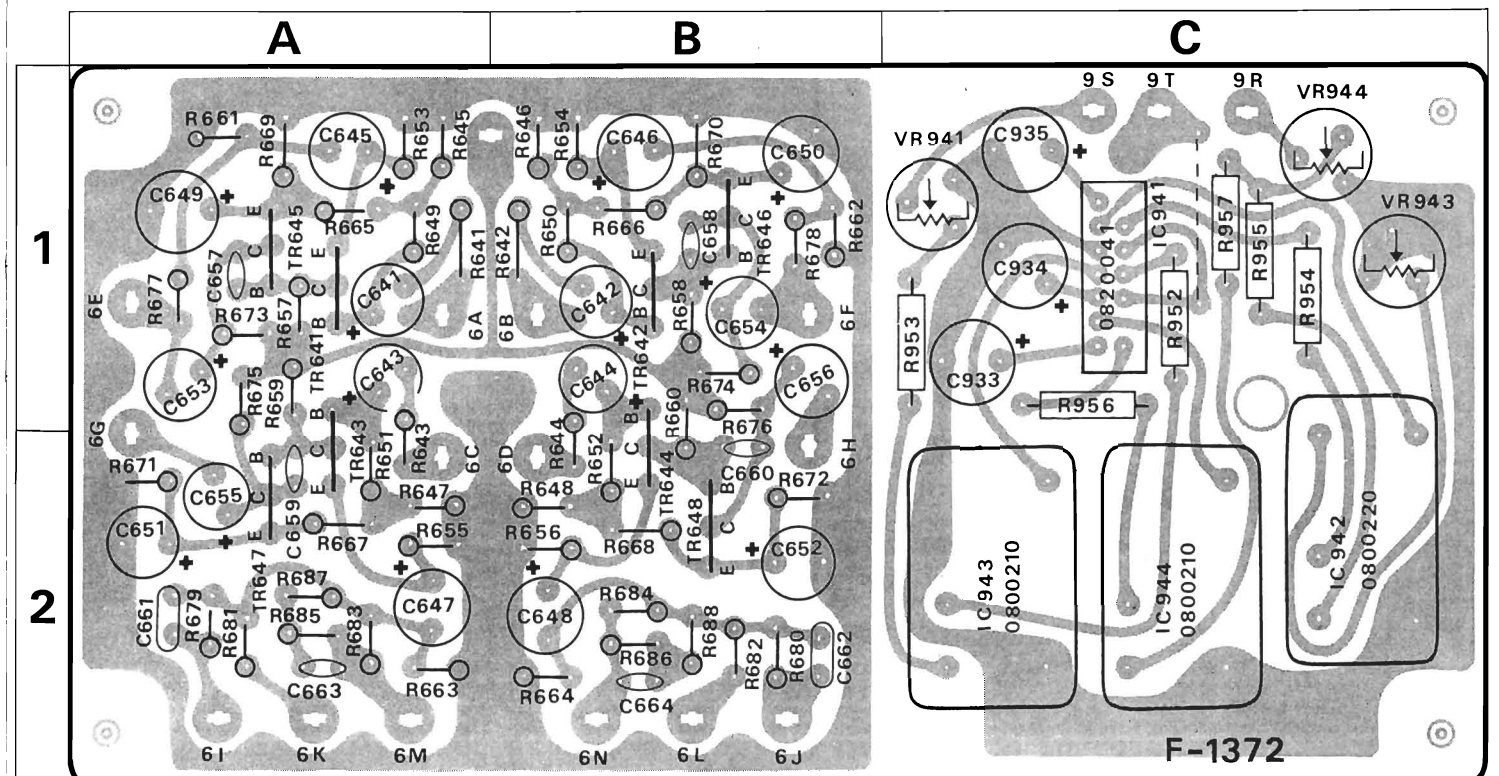

PRINTED CIRCUIT BOARDS AND PARTS LIST

W: Parts No. X: Parts Name Y: Stock No. Z: Position of Parts

TONE BLOCK <F-1363>

W	X	Y	Z
R701	1kΩ	0101102	1 A
R702	1kΩ	0101102	2 B
R703	100kΩ	0101104	1 B
R704	100kΩ	0101104	2 B
R705	39kΩ	0101393	1 B
R706	39kΩ	0101393	2 B
R707	100kΩ	0101104	1 B
R708	100kΩ	0101104	2 B
R709	4.7kΩ	0101472	1 B
R710	4.7kΩ	0101472	2 B
R711	47kΩ	0101473	1 B
R712	47kΩ	0101473	2 B
R713	10kΩ	0101103	1 B
R714	10kΩ	0101103	2 B
R715	5.6kΩ	0101562	1 B 1 C
R716	5.6kΩ	0101562	2 C
R717	1.5kΩ	0101152	1 B 1 C
R718	1.5kΩ	0101152	2 B, C
R719	5.6kΩ	0101562	1 C
R720	5.6kΩ	0101562	2 C
R721	8.2kΩ	0101822	1 C
R722	8.2kΩ	0101822	2 C
R723	220kΩ	0101224	1 C
R724	220kΩ	0101224	2 C
R725	22kΩ	0101223	1 C
R726	22kΩ	0101223	2 C
R727	5.6kΩ	0101562	1 C
R728	5.6kΩ	0101562	2 C
R729	8.2kΩ	0101822	1 C
R730	8.2kΩ	0101822	2 C
R731	390kΩ	0101394	1 C
R732	390kΩ	0101394	2 C
R733	150kΩ	0101154	1 C
R734	150kΩ	0101154	1 C
R735	5.6kΩ	0101562	1, 2 C
R736	5.6kΩ	0101562	2 C
R737	560Ω	0101561	1 C
R738	560Ω	0101561	2 B
R739	100kΩ	0101104	1 C
R740	100kΩ	0101104	2 C
R741	2.2kΩ	0101222	1 A
R742	2.2kΩ	0101222	2 A
R743	470kΩ	0101474	1 A
R744	470kΩ	0101474	1 A
R745	56kΩ	0101563	1 A
R746	56kΩ	0101563	2 A
R747	12kΩ	0101123	1 A
R748	12kΩ	0101123	2 A
R749	2.2kΩ	0101222	1 A
R750	2.2kΩ	0101222	2 A
R751	3.9kΩ	0101392	1 A
R752	3.9kΩ	0101392	2 A
R753	100kΩ	0101104	1 A
R754	100kΩ	0101104	2 A
R755	100Ω	0101101	2 A

W	X	Y	Z
C701	0.01μF	0601107	1 A
C702	0.01μF	0601107	2 B
C703	0.22μF	0601228	1 A
C704	0.22μF	0601228	2 B
C705	100 pF	0660101	1 B
C706	100 pF	0660101	2 B
C707	33μF	0510330	1 B
C708	33μF	0510330	2 B
C709	33μF	0512330	1 B
C710	33μF	0512330	2 B
C711	0.015μF	0601157	1 B, C
C712	0.015μF	0601157	2 B
C713	1μF	0515109	1 B
C714	1μF	0515109	2 B
C715	0.04μF	0601407	1 B
C716	0.04μF	0601407	2 C
C717	0.04μF	0601407	1 C
C718	0.04μF	0601407	2 C
C719	0.0015μF	0601156	1 C
C720	0.0015μF	0601156	2 C
C721	10μF	0515109	1 C
C722	10μF	0515109	1, 2 C
C723	68 pF	0601680	1 C
C724	68 pF	0601680	2 C
C725	47μF	0511470	1 C
C726	47μF	0511470	2 C
C727	1μF	0515109	1 C
C728	1μF	0515109	2 C
C729	1μF	0515109	1 A
C730	1μF	0515109	2 A
C731	47μF	0511470	1 A
C732	47μF	0511470	2 A
C733	1μF	0515109	1 A
C734	1μF	0515109	2 A
C735	100μF	0513101	2 A
TR701	2SC871 (E, F)	0305471, 2	1 B
TR702	2SC871 (E, F)	0305471, 2	2 B
TR703	2SC871 (E, F)	0305471, 2	1 B
TR704	2SC871 (E, F)	0305471, 2	2 B
TR705	2SC871 (F)	0305472	1 C
TR706	2SC871 (F)	0305472	2 C
TR707	2SC871 (F)	0305472	1 A
TR708	2SC871 (F)	0305472	2 A

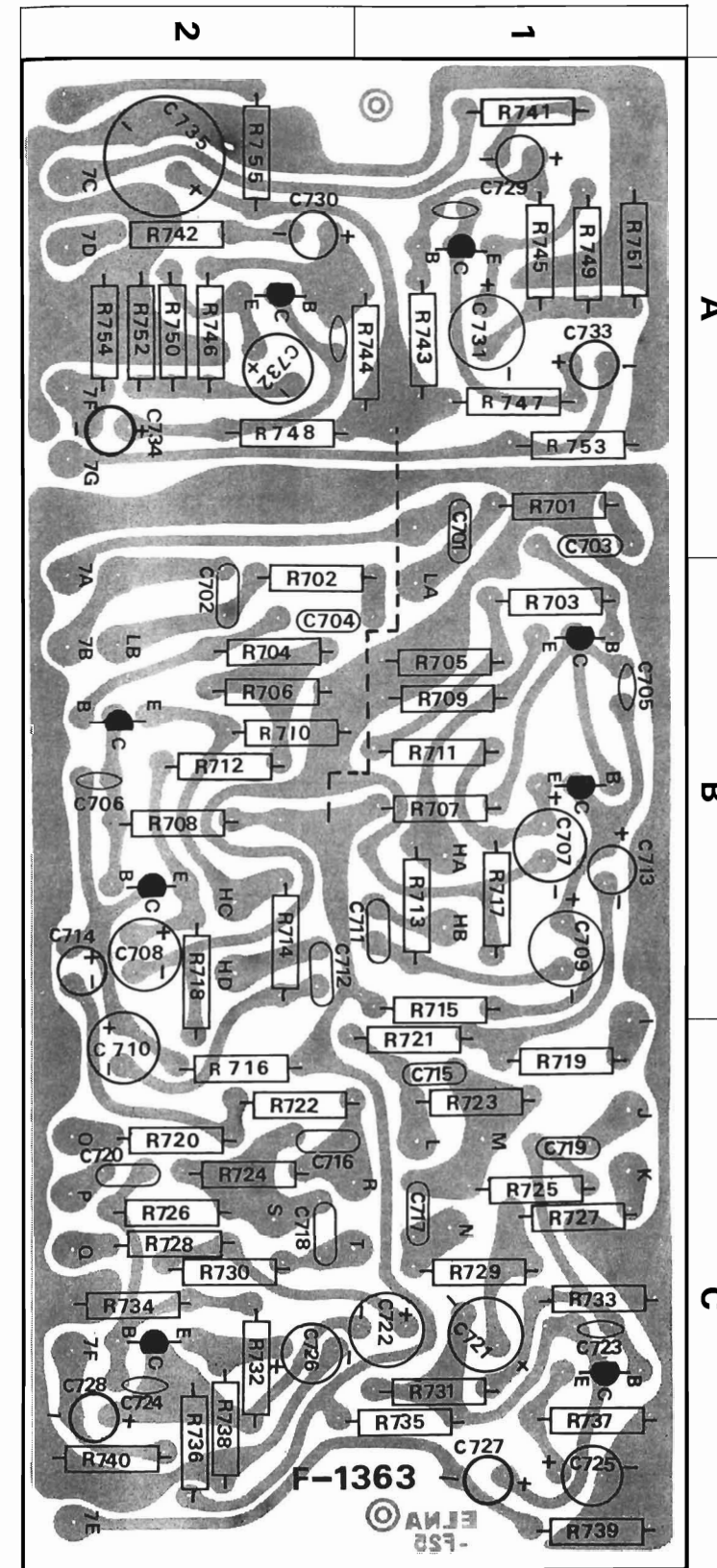

FILTER BLOCK <F-1366>

W	X	Y
R049	1MΩ	0101105
R050	1MΩ	0101105
R051	1MΩ	0101105
R052	1MΩ	0101105
S9(a,b)	High Filter Switch	
S10(a,b)	Low Filter Switch	1130380

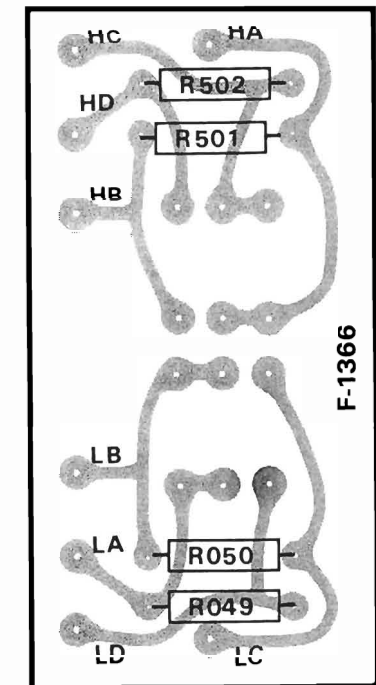

PRINTED CIRCUIT BOARDS AND PARTS LIST

W: Parts No. X: Parts Name Y: Stock No. Z: Position of Parts

DRIVER BLOCK <F-1180E>

W	X	Y	Z	
R801	2.2kΩ	0101222	1A	
R802	150kΩ	0101154	1A	
R803	560kΩ	0101564	1A	
R804	470Ω	0101471	1A	
R805	3.3kΩ	0101332	1A	
R806	3.3kΩ	0101332	1A	
R807	10kΩ	0101103	1A	
R808	47kΩ	0101473	1A	
R809	56kΩ	0101563	1A	
R810	1.8kΩ	0101182	1B	
R811	3.9kΩ	0101392	2B	
R812	39Ω	0101390	2B	
R813	3.3kΩ	0101332	1B	
R814	1.5kΩ	0101152	2A	
R815	220Ω	0101221	2A	
R816	100Ω	0101101	2B	
R817	4.7Ω	0101479	2A	
R818	100Ω	0101101	2A	
R819	6.8Ω	±10% 1/2W SR.	0101689	2A
R820	8.2kΩ	0101822	1A	
R821	2.2kΩ	0101222	1C	
R822	150kΩ	±10% 1/4W CR.	0101154	1C
R823	560kΩ	0101564	1C	

W	X	Y	Z	
R824	470Ω	0101479	1C	
R825	3.3kΩ	0101332	1C	
R826	3.3kΩ	0101332	1C	
R827	10kΩ	0101103	1C	
R828	47kΩ	0101473	1C	
R829	56kΩ	0101563	1C	
R830	1.8kΩ	0101182	1B	
R831	3.9kΩ	±10% 1/4W CR.	0101392	2B
R832	39Ω	0101390	2B	
R833	3.3kΩ	0101332	1B	
R834	1.5kΩ	0101152	2C	
R835	220Ω	0101221	2C	
R836	100Ω	0101101	2B	
R837	4.7Ω	0101479	2C	
R838	100Ω	0101101	2C	
R839	6.8Ω	±10% 1/2W SR.	0101689	2C
R840	8.2kΩ	±10% 1/4W CR.	0101822	1C
C801	0.22μF	±10% 50 V MC.	0601228	1A
C802	100μF	25 V EC.	0513101	1A
C803	220μF	10 V EC.	0511221	1A
C804	1μF	50 V EC.	0515109	1A
C805	33μF	50 V EC.	0515330	1B

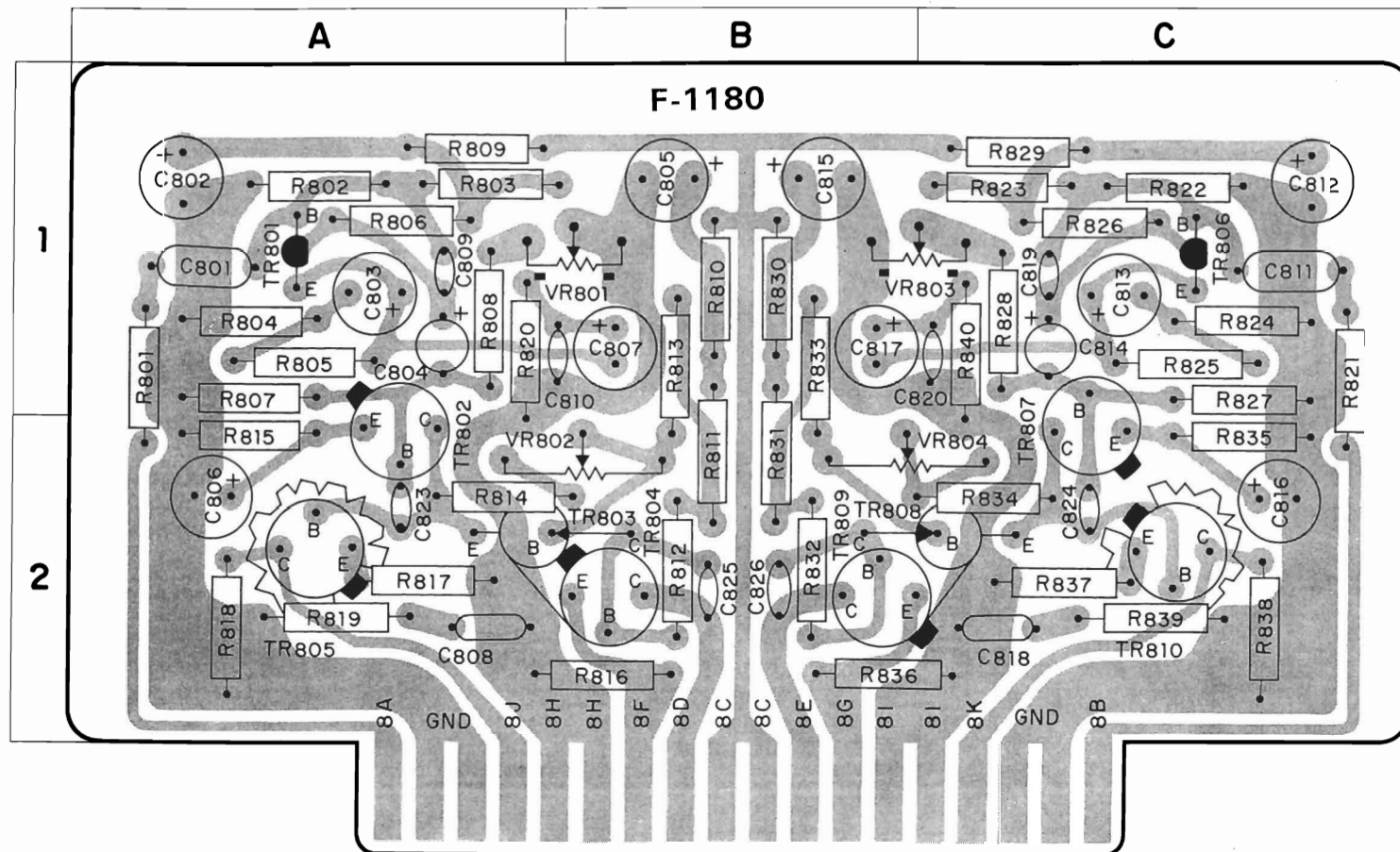

POWER BLOCK <F-1360>

W	X	Y	Z	
C806	100μF	6.3 V EC.	05101101	2A
C807	10μF	50 V EC.	0515100	1B
C808	0.047μF	±10% 50 V MC.	0601477	2A
C809	47pF	±10% 50 V CC.	0660470	1A
C811	0.22μF	±10% 50 V MC.	0601228	1C
C812	100μF	25 V EC.	0513101	1C
C813	220μF	10 V EC.	0511221	1C
C814	1μF	50 V EC.	0515109	1C
C815	33μF	50 V EC.	0515330	1B
C816	100μF	6.3 V EC.	05101101	2C
C817	10μF	50 V EC.	0515100	1B
C818	0.047μF	±10% 50 V MC.	0601477	2C
C819	47pF	±10% 50 V CC.	0660470	1C
C823	47pF	±10% 50 V CC.	0660470	2A
C824	47pF	±10% 50 V CC.	0660470	2C
C825	330pF	50 V EC.	0660331	2B
C826	330pF	50 V EC.	0660331	2B
VR801	200kΩ (B) AC Balance Adjustor	1030150	1A, B	
VR802	1kΩ (B) DC Bias Adjustor	1030690	2A, B	
VR803	200kΩ (B) AC Balance Adjustor	1030150	1B, C	
VR804	1kΩ (B) DC Bias Adjustor	1030690	2B, C	
TR801	2SC458LG (B)	0305310	1A	
TR802	2SC1124 (2, 3)	0305900, 1, 2	2A	
TR803	2SC281 (B)	0305141	2A, B	
TR804	2SC959 (L, M)	0305741, 2	2B	
TR805	2SA606 (L, M)	0300211, 2	2A	
TR806	2SC458LG (B)	0305310	1C	
TR807	2SC1124 (2, 3)	0305900, 1, 2	2C	
TR808	2SC281 (B)	0305141	2B, C	
TR809	2SC959 (L, M)	0305741, 2	2B	
TR810	2SA606 (L, M)	0300211, 2	2C	

W	X	Y
R001	47Ω ±10% 2W CeR.	0152470
R002	12kΩ ±10% 1/4W CR.	0101123
C001	1000μF 10 V EC.	0511102
C002	100μF 75 V EC.	0519301
C003	0.022μF +80% -20% 50 V CC.	0657223
C004	0.0047μF +80% -20% 500V CC.	0659012
C005	0.0047μF +80% -20% 500V CC.	0659012
TR001	2SC959 (L, M)	0305741, 2
D001	ESAC02N-03	0310910
D002	ESAC02C-03	0310900
D003	ESAC02N-03	0310910
D004	ESAC02C-03	0310900
D005	10D1	0310340

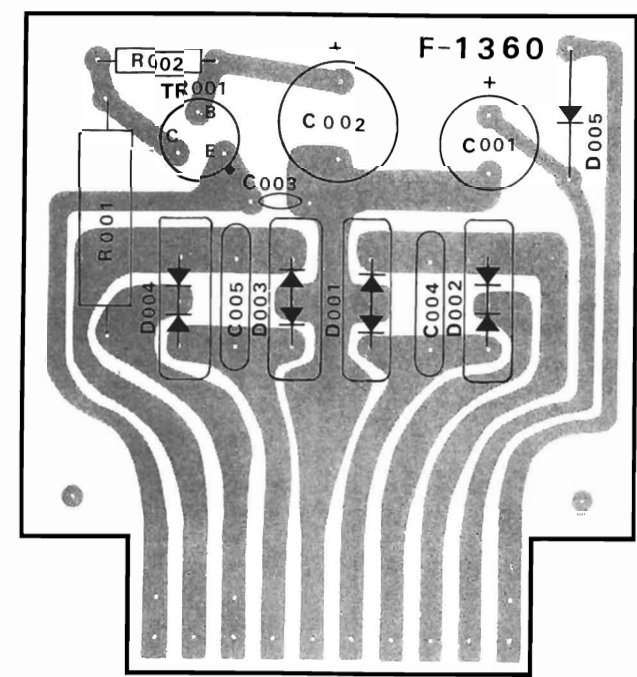

PRINTED CIRCUIT BOARDS AND PARTS LIST

W: Parts No. X: Parts Name Y: Stock No. Z: Position of Parts

POWER BLOCK <F-1362>

W	X	Y	Z
R003	47Ω	0152470	1 B
R004	22Ω	0152220	1 B
R005	3.3kΩ ±10%	0101332	1 B
R006	1.8kΩ ±10%	0111182	1 B
R007	1.2kΩ ±10%	0101122	1 B
R008	47Ω ±10%	0111470	1 A
R009	820Ω ±10%	0101821	1 A
R010	270Ω ±10%	0152271	1 A
R011	150Ω ±10%	0101151	1 B
C006	0.01μF +80% -20%	0659011	1 B
C007	0.01μF	0659011	1 B
C008	220μF	0515221	1 B
C009	220μF	0515221	1 A, B
C010	0.022μF +80% -20%	0657223	1 B
C011	220μF	0513221	1 B

W	X	Y	Z
C012	470μF	0513221	1 B
C013	0.022μF +80% -20%	0657223	1 A
C014	220μF	0515221	1 A
C015	100μF	0512101	1 A
C016	220μF	0513221	1 A, B
C017	220μF	0513221	1 A
C018	220μF	0513221	1 A
TR002	2SC971 (2, 3)	0305530, 1	1 B
TR003	2SD92 (Y, BL)	0308072, 3	1 A
D006	10DC-IN	0310680	1 B
ZD001	RD24A (M, N)	0315410, 20	1 B
ZD002	ZB1-27A	0315110	1 A
ZD003	RD13A (L, M)	0315290, 300	1 A

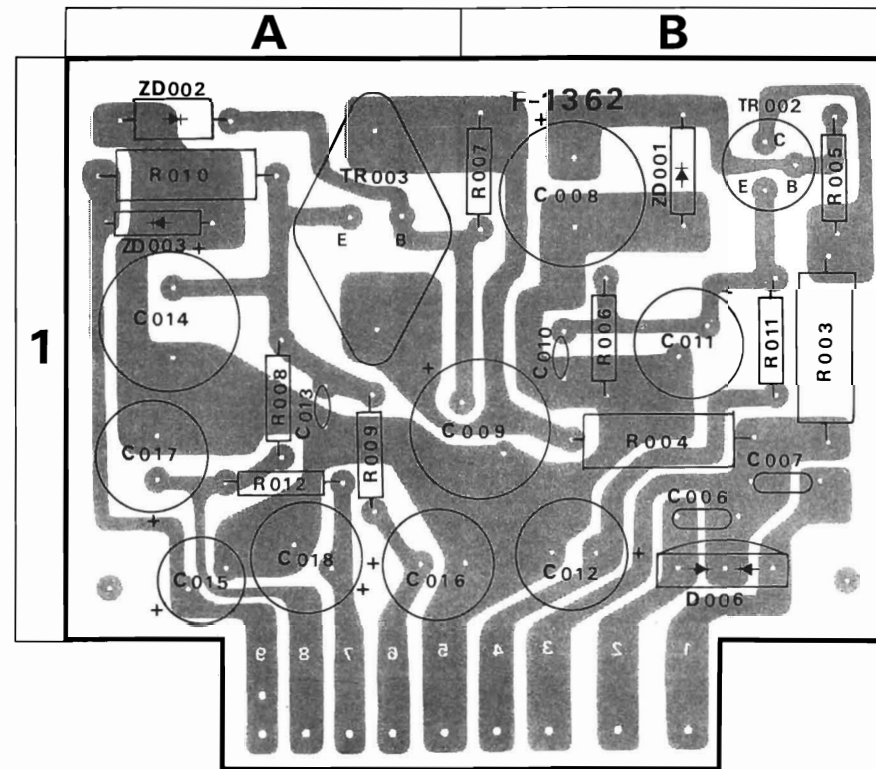

OTHER PARTS AND THEIR POSITION ON CAHSSIS

W: Parts No. X: Parts Name Y: Stock No.

W	X	Y
R022	47Ω	0101470
R023	5.6kΩ	0101562
R024	100kΩ	0101104
R025	100kΩ	0101104
R026	390kΩ	0101392
R027	390kΩ	0101392
R028	18kΩ	0101183
R029	100kΩ	0101104
R030	100kΩ	0101104
R031	390kΩ	0101392
R032	390kΩ	0101392
R033	100kΩ	0101104
R034	100kΩ	0101104
R035	390kΩ	0101394
R036	390kΩ	0101394
R037	8.2kΩ	0101822
R038	8.2kΩ	0101822
R053	330Ω	0111331
R054	330Ω	0111331
R055	330Ω	0111331
R056	330Ω	0111331
R057	0.47Ω	0152478
R058	0.47Ω	0152478
R059	0.47Ω	0152478
R060	0.47Ω	0152478
R061	0.47Ω	0152478
R062	0.47Ω	0152478
R063	0.47Ω	0152478
R064	0.47Ω	0152478
R065	27kΩ	0101273
R066	24kΩ	0101273
R067	47kΩ	0101473
R068	47kΩ	0101473
R069	560Ω	0111561
R072	560Ω	0111561
R073	4.7Ω	0111479
VR001~006	250kΩ(B) × 4 } Volume 100kΩ(B) × 2 }	1090020, 1 1090020, 1 1040090, 1 1040090, 1
VR007, 008	250kΩ(MN) Front Balance	1040100, 1
VR009, 010	250kΩ(MN) Rear Balance	1020130, 1
VR011~014	250kΩ(MN) × 2 Main Balance	1020130, 1
VR015, 016	100kΩ(B) × 2 Treble	1020130, 1
VR017, 018	100kΩ(B) × 2 Bass	1020130, 1
C021	0.022μF	0591227
C022	0.0047μF	0591476
C023	2200μF	0559820
C024	2200μF	0559820
C025	1000μF	0559304
C034	2200μF	0559820
C035	2200μF	0559820
C036	2200μF	0559820
C037	2200μF	0559820
C038	0.022μF +80% -20%	0656223
C039	0.022μF	0656223
C040	47μF 6.3 V	0510470
TR004	2SD180 (L, M, N)	0308061, 2, 3
TR005		0308061, 2, 3
TR006	2SD180 (L, M, N)	0308061, 2, 3
TR007		0308061, 2, 3
TR008		0308061, 2, 3
TR009		0308061, 2, 3
TR010		0308061, 2, 3
TR011		0308061, 2, 3
S1(a~n)	Selector Switch	1105110, 1
S2(a~f)	Function Switch	1102320
S3(a~g)	Mode Switch	1103391
S11(a~b)	Front Speakers Switch Y-1-4-4	1101360, 1
S12(a~b)	Rear Speakers Switch Y-1-4-4	1101360, 1
S13	Power Switch	1130350
S14	AM Antenna Switch	1110090
T001	Power Transformer	4001000
L001	300Ω : 75Ω FM balloon	4290021
L002	AM Bar Antenna	4200490
J001	Headphones Jack (Front)	2430071
J002	Headphones Jack (Rear)	2430071
J003	Tape Rec. 2 Jack	2430060
J004	Tape Mon. 2 Jack	2430060
DIN001	DIN Connector (2-Channel)	2430040
DIN002	DIN Connector (4-Channel Front)	2430040
DIN003	DIN Connector (4-Channel Rear)	2430040
PU001	Voltage Selector Socket Main Voltage Selector Plug Sub Voltage Selector Plug	2410170 2410180 2410190
CO001~003	AC Outlet	2450040
M001	Signal Meter 200μA	4300470
F001	5A Power Fuse (100~127V) 3A Power Fuse (220~250V)	0430062 0430020
F002~005	2.5A Quick Acting Fuse	0433242
PL001	6.3V 0.075A Dial Pointer Lamp	0400200
PL007	7V 0.2A PHONO 2 Indicator	0400150
PL008	7V 0.2A PHONO 1 Indicator	0400150
PL009	7V 0.2A FM Indicator	0400150
PL010	7V 0.2A AM Indicator	0400150
PL011	7V 0.2A AUX (2CH) Indicator	0400150
PL012	7V 0.2A AUX (4CH) Indicator	0400150
PL013	7V 0.2A 4-Channel Indicator	0400150
PL014	6.3V 0.075A 2, 4 Digital Indicator	0400154
PL015		0400200
PL016		0400200
PL017	6.3V 0.25A Signal Meter Lamp	0420020
PL018	6V 0.1A FM Stereo Indicator	0400160

OTHER PARTS AND THEIR POSITION ON CHASSIS

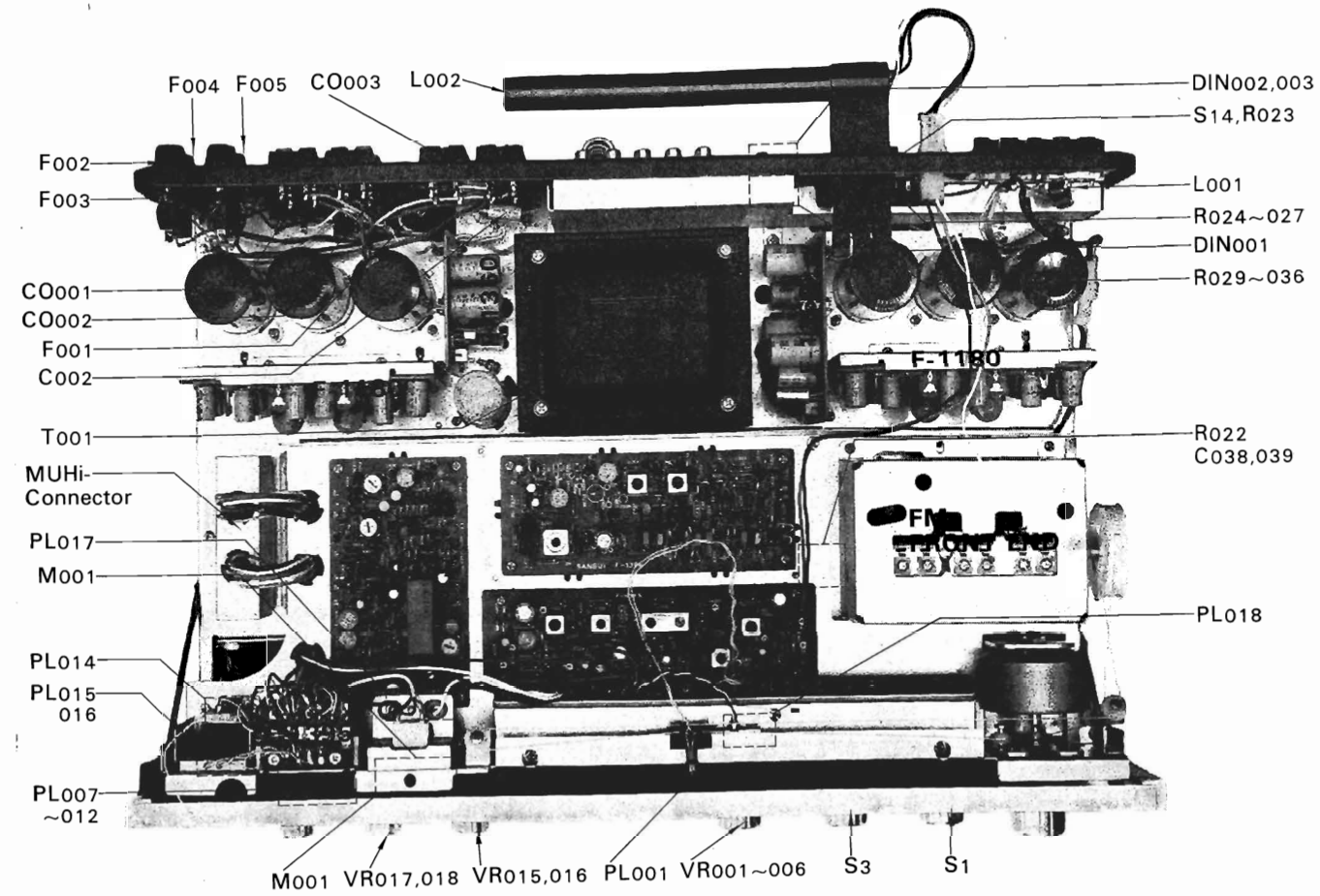

* Manufacturer reserves right to change design and/or specifications without notice for purpose of improvement.

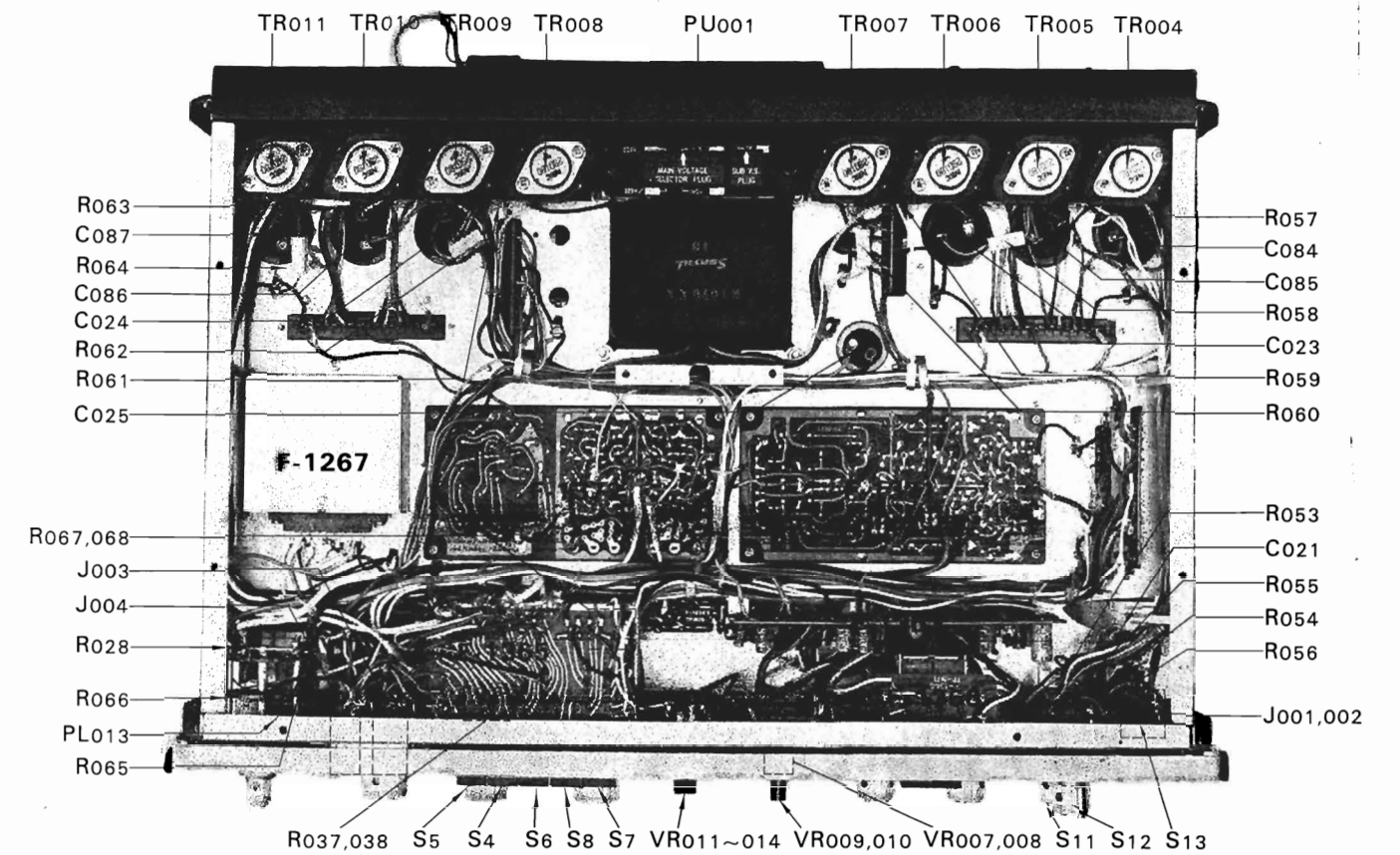



SANSUI ELECTRIC COMPANY LIMITED

Head Office; 14-1, 2-chome, Izumi, Suginami-ku, Tokyo, Japan. TEL. 323-1111

Printed in Japan (81030M)