

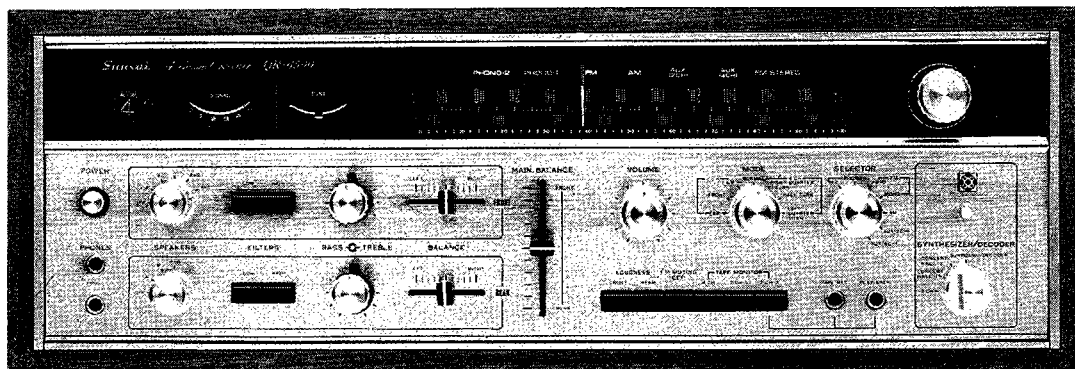

# SERVICE MANUAL

## 4-CHANNEL RECEIVER

# SANSUI QR-6500



*Sansui*

SANSUI ELECTRIC CO., LTD.

# **CONTENTS**

---

GENERAL TROUBLESHOOTING CHART .....	3, 4
DISASSEMBLY PROCEDURE .....	5, 6
TEST POINTS .....	7
SCHEMATIC DIAGRAMS.....	8, 9, 10, 11
ALIGNMENT.....	12, 13, 14
PRINTED CIRCUIT BOARDS AND PARTS LIST	
..... 15, 16, 17, 18, 19, 20, 21, 22, 23, 24, 25, 26, 27, 28, 29	
OTHER PARTS AND THEIR POSITION ON CHASSIS	
.....	30, 31, 32

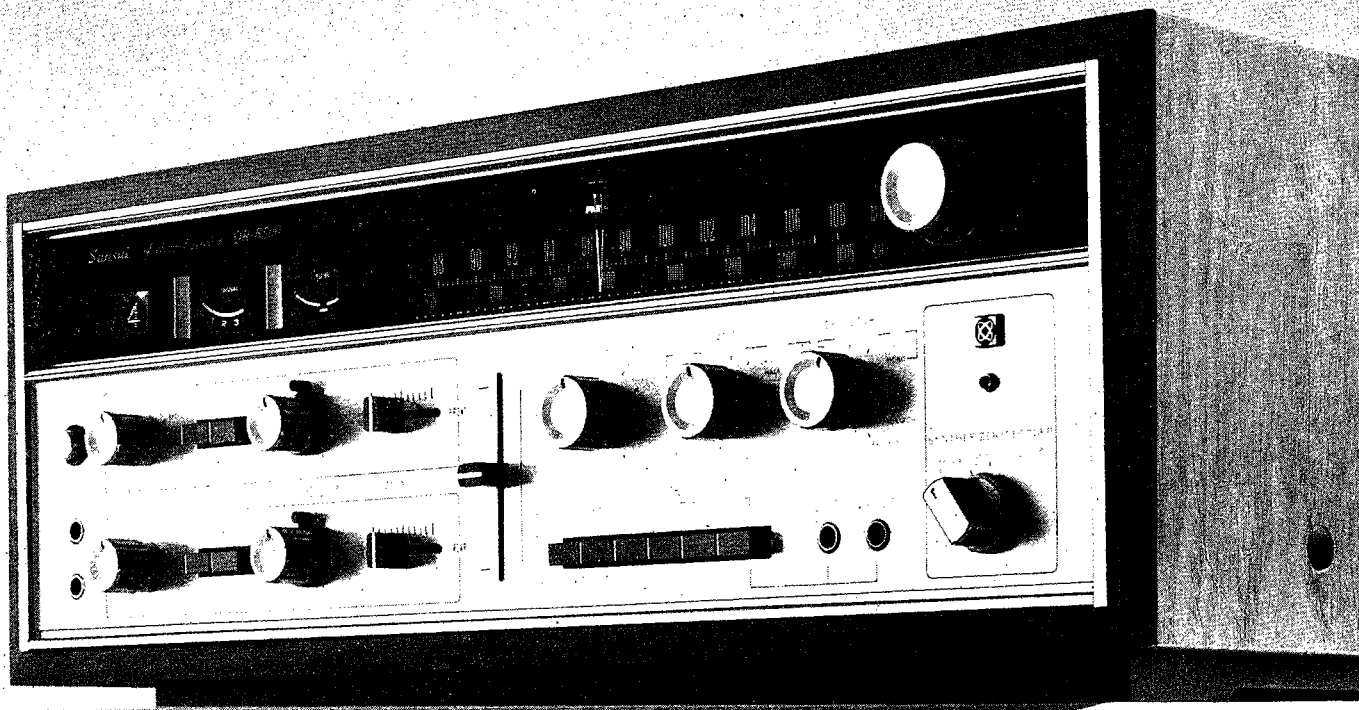

# GENERAL TROUBLESHOOTING CHART

If the receiver is otherwise operating satisfactory, the more common causes of trouble may generally be attributed to the following:

1. Incorrect connections or loose terminal contacts. Check the speakers, turntable, tape deck, antenna and power cord.
2. Improper operation. Before operating any audio com-

ponent, be sure to read its manufacture's instructions.

3. Improper location of audio components. The proper positioning of components, such as speakers and turntable, is essential to the maximum stereo enjoyments.

4. Defective audio components.

The following are some other common causes of malfunction and what to do about them.

PROGRAM	SYMPTOM	PROBABLE CAUSE	WHAT TO DO
AM, FM or MPX reception	A. Constant or intermittent noise heard at times or in certain areas	<ul style="list-style-type: none"> <li>* Discharge or oscillation caused by electrical appliances, such as fluorescent lamp, TV set, D.C. motor rectifier or oscillator</li> <li>* Natural phenomena, such as atmospheric, static or thunderbolts</li> <li>* Insufficient antenna input due to ferroconcrete wall or long distance from station</li> </ul>	<ul style="list-style-type: none"> <li>* Attach noise limiter to electrical appliance producing noise, or attach it to the receiver's power source</li> <li>* Install outdoor antenna and ground receiver to raise SN ratio</li> <li>* Reverse power cord plug/receptacle connections</li> <li>* If noise occurs at certain frequency, attach wave trap to input</li> <li>* Keep receiver at proper distance from other electrical appliances</li> </ul>
AM reception	A. Noise heard at a particular time of a day, in a certain area or over part of dial	<ul style="list-style-type: none"> <li>* Peculiar to AM broadcasts</li> </ul>	<ul style="list-style-type: none"> <li>* Install antenna for maximum antenna efficiency. See RADIO RECEPTION in operating instructions booklet</li> <li>* In some cases, noise can be eliminated by grounding receiver or reversing power cord plug/receptacle connections</li> </ul>
	B. High-frequency noise	<ul style="list-style-type: none"> <li>* Adjacent-channel interference or beat interference</li> <li>* TV set too close to audio system</li> </ul>	<ul style="list-style-type: none"> <li>* Such noise cannot be completely eliminated by the receiver, but it is advisable to turn Treble control counterclockwise, turn on High Filter</li> <li>* Keep TV set at proper distance from stereo system</li> </ul>
FM reception	A. Noisy	<ul style="list-style-type: none"> <li>* Poor noise limiter effect or too low SN ratio due to insufficient antenna input</li> </ul> <p>Note: FM reception is affected considerably by transmission conditions of station, such as power and antenna efficiency. As a result, you may receive one station quite well while receiving another station poorly</p>	<ul style="list-style-type: none"> <li>* Install antenna (supplied) for maximum signal strength</li> <li>* If this does not prove effective, use exclusive FM outdoor antenna. If using TV antenna for both TV and FM with a divider, make sure TV reception is not affected</li> <li>* Excessively long lead-in wire of antenna may cause noise</li> </ul>
	B. A series of pops	<ul style="list-style-type: none"> <li>* Ignition noise caused by starting of nearby automobile engine</li> </ul>	<ul style="list-style-type: none"> <li>* Install antenna and its lead-in wire at proper distance from street or increase antenna input as described before</li> </ul>
	C. Tuning noise between stations	<ul style="list-style-type: none"> <li>* Results from nature of FM reception</li> <li>* FM Muting Release switch depressed</li> </ul>	<ul style="list-style-type: none"> <li>* Release FM Muting Release switch</li> <li>* Ditto</li> </ul>

PROGRAM	SYMPTOM	PROBABLE CAUSE	WHAT TO DO
FM-MPX reception	A. Noise heard during FM-MPX reception but inaudible during FM mono reception	* Weaker signal because service area of FM-MPX broadcast is only half that of FM mono broadcast	* Orient antenna for maximum antenna input * Switch on High Filter and/on turn Treble control counterclockwise
	B. Channel separation deteriorates during reception	* Excess heat	* Circulation of room air is important to receiver. Be sure that receiver is well ventilated
	C. Stereo indicator blinks on and off	* Interference	* Indicator is not faulty, adjust VR <sub>403</sub>
Record playing or tape playback	A. Hum or howling	* Turntable placed directly on speaker * Wire other than shielded cable used * Loose terminal contact * Shielded cable too close to power cord, fluorescent lamp or other appliances * Nearby amateur radio station or TV transmission antenna	* Place cushion between turntable and speaker cabinet or place them away from each other * Connecting shielded cables should be as short as possible * Turn on Low Filter and turn Bass control counterclockwise * Consult nearest Radio Regulatory Bureau
	B. Surface noise	* Worn or old record * Worn phono stylus * Phono stylus is dusty * Improper stylus pressure	* Recondition playback head of tape deck or the stylus of turntable * Turn Treble control counterclockwise * Turn High Filter on
4-channel stereo playback	A. Position of musical instruments and voice not clear	* Incorrect phasing of speakers or input connections	* Check phasing of speakers and input connections * Change rear speaker position and/or direction

# DISASSEMBLY PROCEDURE

## REMOVING THE WOOD CASE, FRONT PANEL AND BOTTOM BOARD

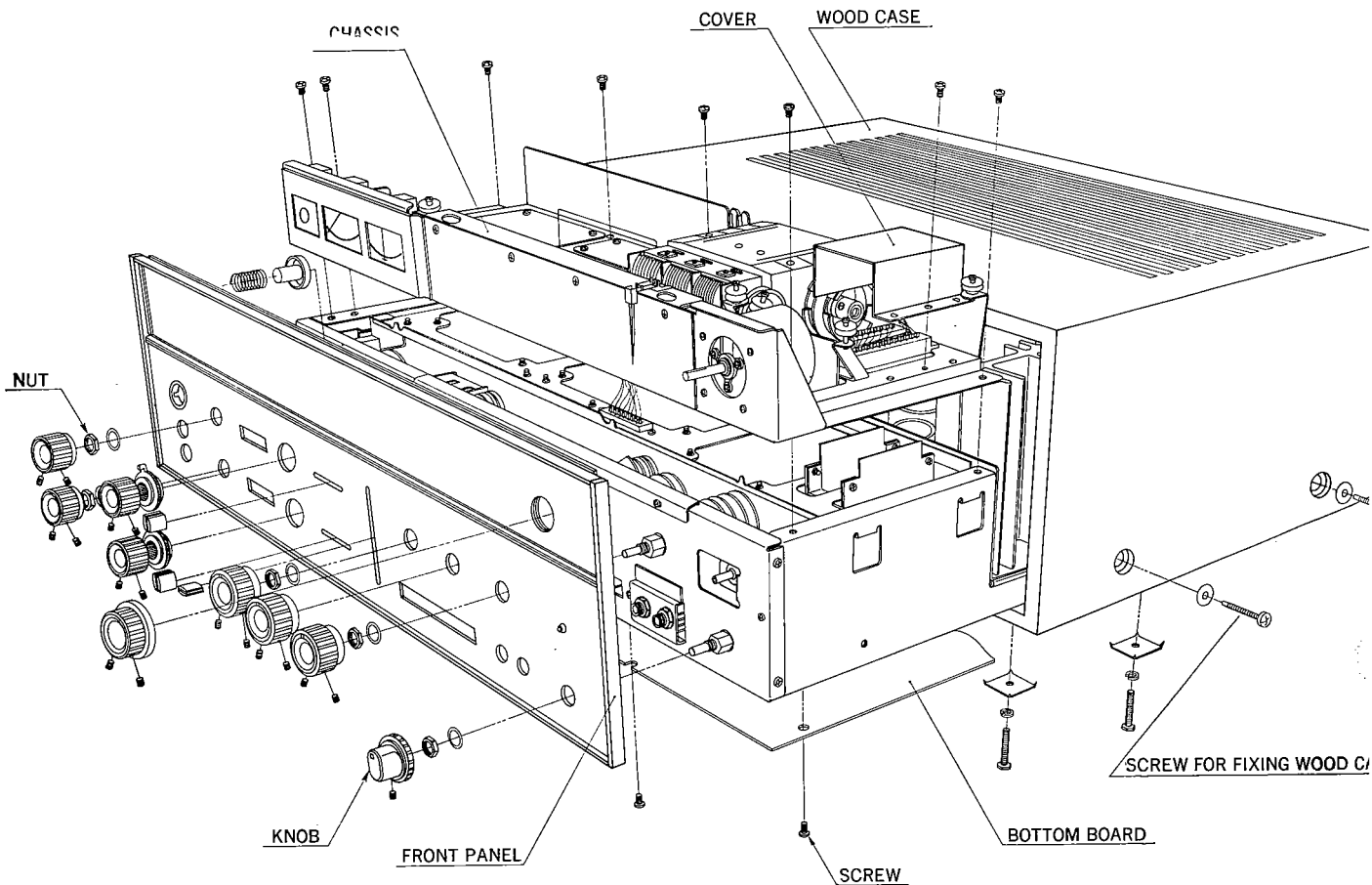

## DIAL MECHANISM

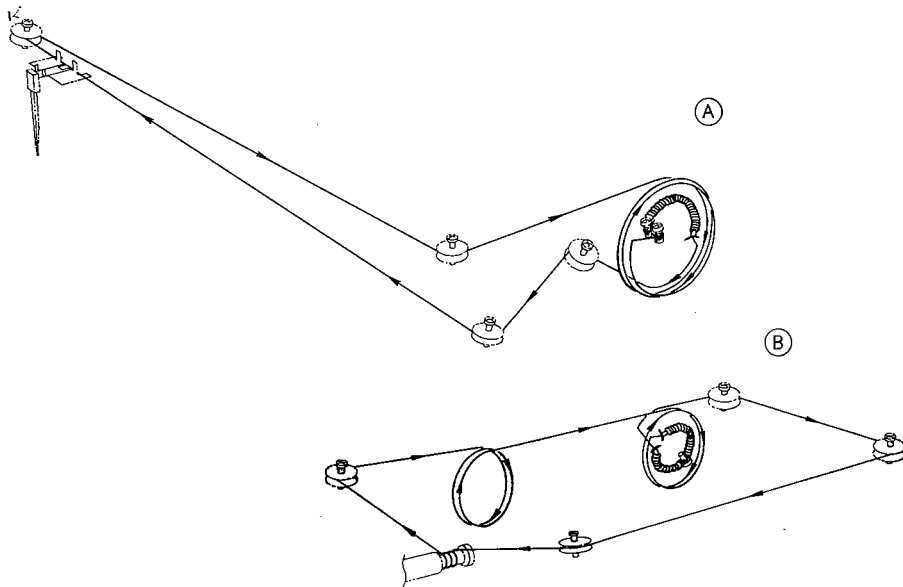

The Tuner Block, if necessary, can be independently separated from the rest of the receiver for examination and servicing purposes. To do so, follow these simple steps:

1. Remove the seven screws fastening the Tuner Block to the receiver proper.
2. Pull off the two grounding mesh wires marked in the photograph below.
3. Remove the shielding cover of the multi-connector (see photo below), then unplug the multi-connector very carefully.
4. Free the Tuning Control and pull it out. The Tuner Block now floats freely off the receiver proper, but if you need disconnect it completely, move on to steps 5 and 6.
5. Pull off the lead wires of the AM ferrite bar antenna. (When you re-assemble, connect the red wire to F-1085-5 (3A), the grey and black ones to F-1085-5 (3B), and the yellow one to VC<sub>001</sub>.)
6. Disconnect, in the middle, the coaxial cable connecting the FM DIST/LOC Switch to the FM Frontend.

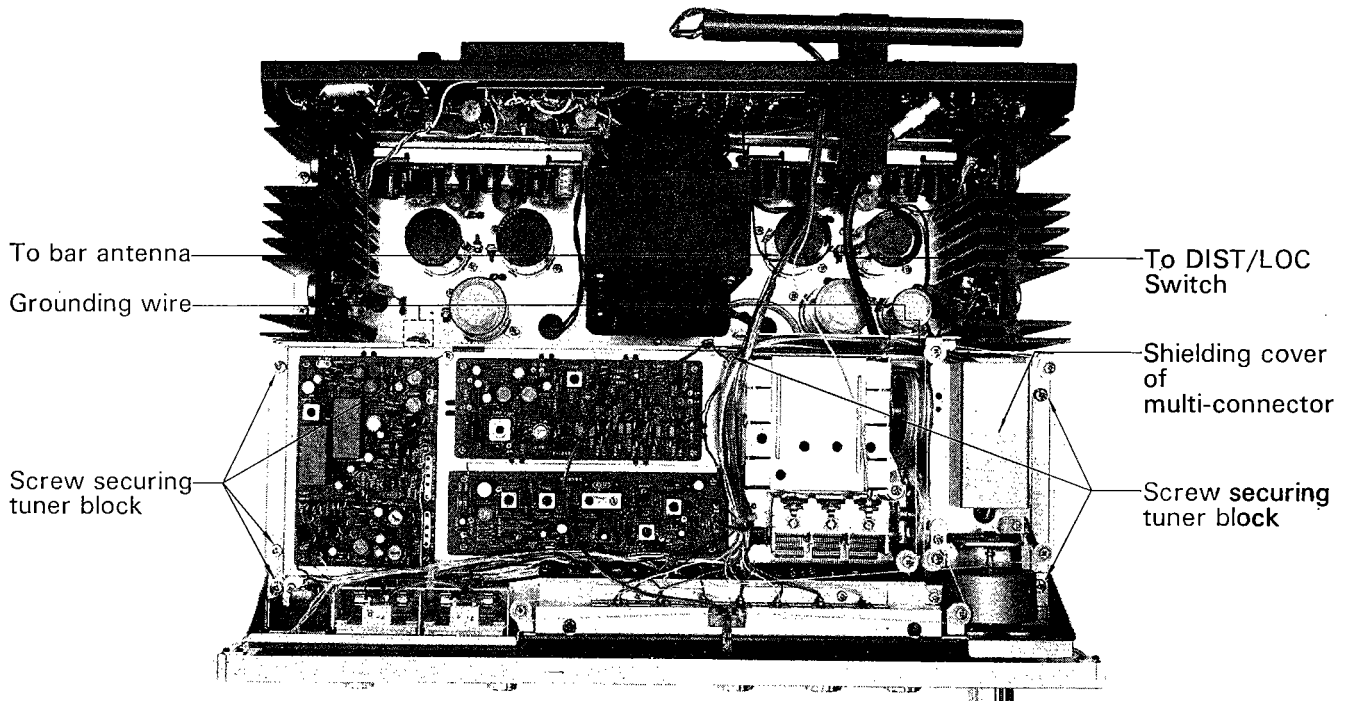

# TEST POINTS

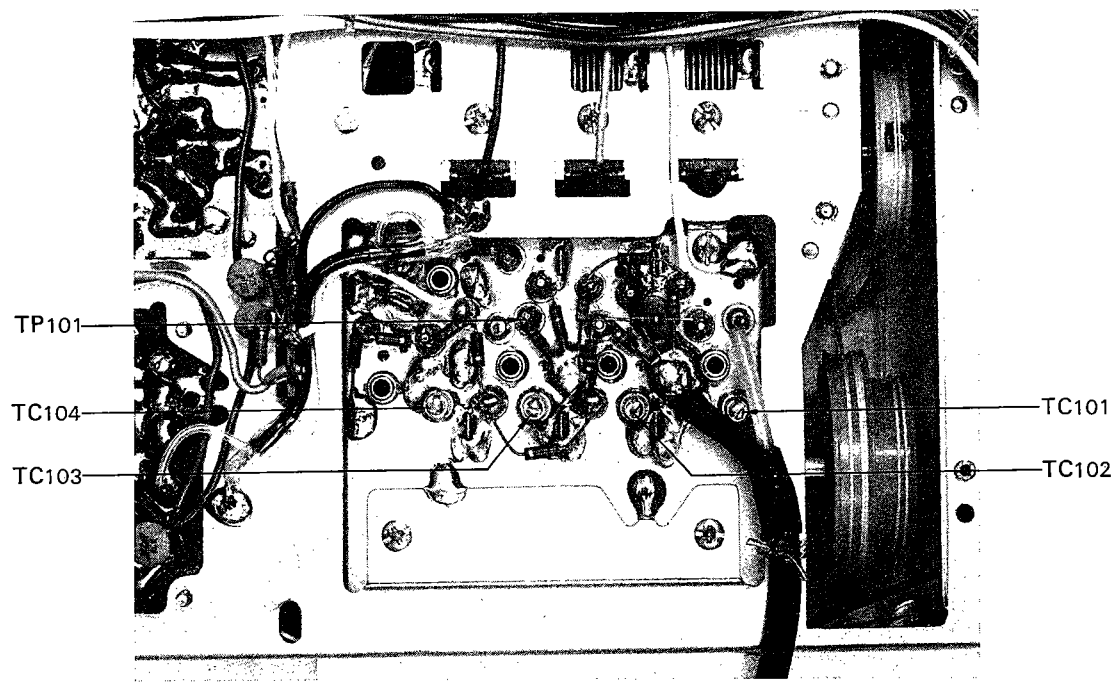
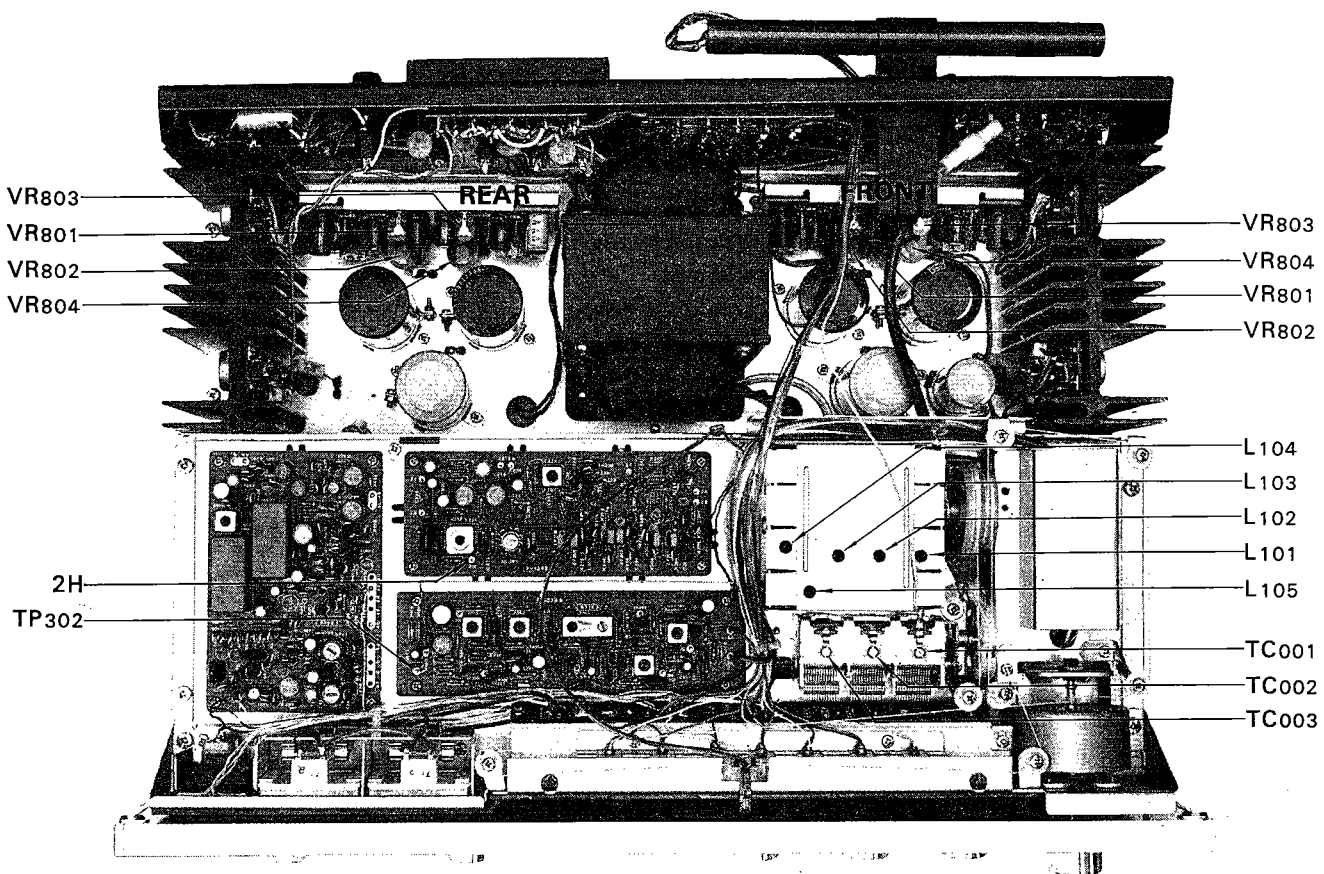





# DIAGRAM OF TUNER SECTION

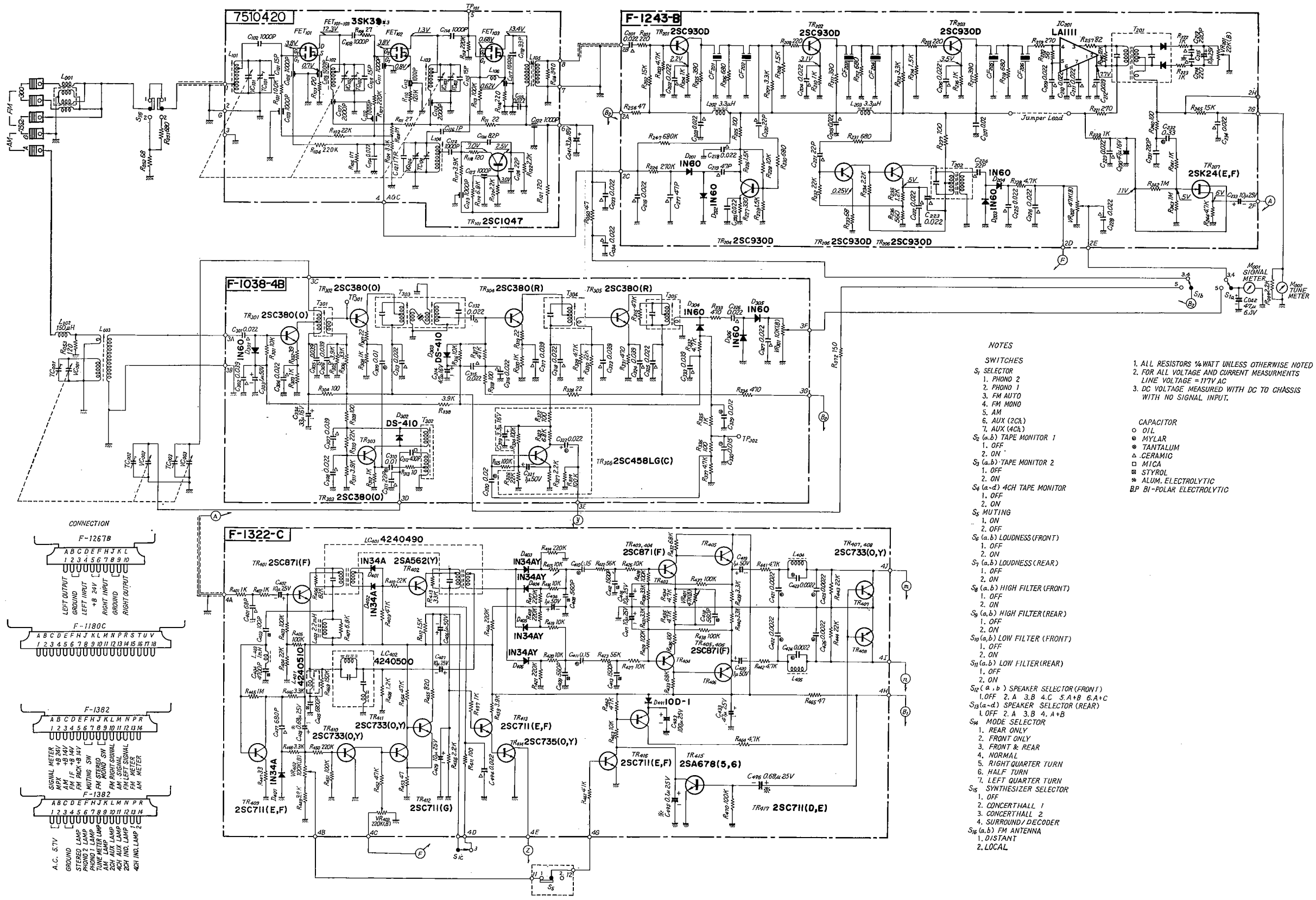

- NOTES**
- SWITCHES**
1. PHONO 2
  2. PHONO 1
  3. FM AUTO
  4. FM MONO
  5. AM
  6. AUX (2CA)
  7. AUX (4CA)
- S<sub>1</sub> (a,b) TAPE MONITOR 1**
1. OFF
  2. ON
- S<sub>2</sub> (a,b) TAPE MONITOR 2**
1. OFF
  2. ON
- S<sub>3</sub> (a-b) 4CH TAPE MONITOR**
1. OFF
  2. ON
- S<sub>4</sub> MUTING**
1. ON
  2. OFF
- S<sub>5</sub> (a,b) LOUDNESS (FRONT)**
1. OFF
  2. ON
- S<sub>6</sub> (a,b) LOUDNESS (REAR)**
1. OFF
  2. ON
- S<sub>7</sub> (a,b) HIGH FILTER (FRONT)**
1. OFF
  2. ON
- S<sub>8</sub> (a,b) HIGH FILTER (REAR)**
1. OFF
  2. ON
- S<sub>9</sub> (a,b) LOW FILTER (FRONT)**
1. OFF
  2. ON
- S<sub>10</sub> (a,b) LOW FILTER (REAR)**
1. OFF
  2. ON
- S<sub>11</sub> (a,b) SPEAKER SELECTOR (FRONT)**
1. OFF
  2. A
  3. B
  4. C
  5. A+B
  6. A+C
- S<sub>12</sub> (a-b) SPEAKER SELECTOR (REAR)**
1. OFF
  2. A
  3. B
  4. A+B
- S<sub>13</sub> MODE SELECTOR**
1. REAR ONLY
  2. FRONT ONLY
  3. FRONT & REAR
  4. NORMAL
  5. RIGHT QUARTER TURN
  6. HALF TURN
  7. LEFT QUARTER TURN
- S<sub>14</sub> SYNTHESIZER SELECTOR**
1. OFF
  2. CONCERTHALL 1
  3. CONCERTHALL 2
  4. SURROUND / DECODER
- S<sub>15</sub> (a,b) FM ANTENNA**
1. D1STANT
  2. LOCAL
- CAPACITOR**
- OIL
  - MYLAR
  - TANTALUM
  - △ CERAMIC
  - MICA
  - STYROL
  - ALUM. ELECTROLYTIC
  - BP BI-POLAR ELECTROLYTIC

# ALIGNMENT

## FM ALIGNMENT PROCEDURE

NOTE: Set the FM signal generator level to minimum first.

Any internal parts replacement or changes you make in the QR-6500 requires proper alignment again, Test points, alignment procedures and schematic diagrams are given on pages 7~14.

Equipment required: 1. Sweep Generator 2. Oscilloscope 3. FM Signal Generator 4. Multiplex Stereo Generator 5. AC V.T.V.M.

STEP	ALIGN	GENERATOR	FEED SIGNAL	OUTPUT INDICATOR	DIAL SETTING	ADJUST	ADJUST FOR
1.	Discriminator	10.7MHz ±200kHz Sweep generator	To TP <sub>101</sub> via the 10pF ceramic capacitor	Oscilloscope is connected to 2H		FM Discriminator transformer T <sub>201</sub> primary and secondary	S curve
2.	O.S.C.	FM signal generator 88MHz 400Hz 100% Modulation	To antenna terminals	Oscilloscope and V.T.V.M. at output load	88MHz	O.S.C. coil L <sub>104</sub>	Maximum
3.	O.S.C.	FM signal generator 108MHz 400Hz 100% Modulation	To antenna terminals	Oscilloscope and V.T.V.M. at output load	108MHz	O.S.C. trimmer TC <sub>104</sub>	Maximum
4.	Repeat 2 and 3						
5.	RF Amp. Circuit	FM signal generator 90MHz 400Hz 100% Modulation	To antenna terminals	Oscilloscope and V.T.V.M. at output load	90MHz	Antenna coil L <sub>101</sub> , L <sub>102</sub> and L <sub>103</sub>	Maximum
6.	RF Amp. Circuit	FM signal generator 106MHz 400Hz 100% Modulation	To antenna terminals	Oscilloscope and V.T.V.M. at output load	106MHz	Trimmer TC <sub>101</sub> , TC <sub>102</sub> and TC <sub>103</sub>	Maximum
7.	Repeat 5 and 6.						

FM DISCRIMINATOR WAVE FORM

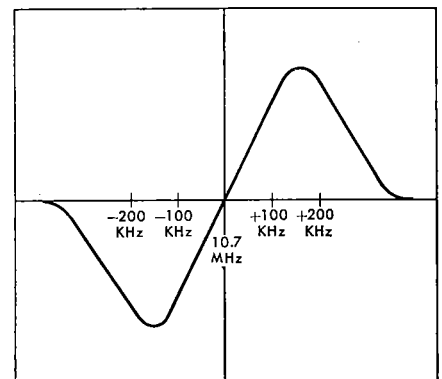

# ALIGNMENT

## FM MULTIPLEX CIRCUIT

STEP	ALIGN	GENERATOR	FEED SIGNAL	OUTPUT INDICATOR	DIAL SETTING	ADJUST	ADJUST FOR
1.	19kHz phase	FM signal generator—98MHz Stereo signal generator—composite signal with pilot signal, left chan, 30% modulation.	To antenna terminal	Connect distortion meter to right channel load terminal	98MHz	L <sub>401</sub>	Minimum distortion in right chan.
2.	Stereo separation	Same as above	Same as above	Connect oscilloscope and V.T.V.M. to load terminal	Same as above	VR <sub>401</sub>	Maximum separation

## AM ALIGNMENT PROCEDURE

NOTE: To align, set the AM signal generator level to minimum.

STEP	ALIGN	GENERATOR	FEED SIGNAL	OUTPUT INDICATOR	DIAL SETTING	ADJUST	ADJUST FOR
1.	IF Transformer	455kHz $\pm$ 30kHz Sweep-generator	Antenna terminals	Oscilloscope and V.T.V.M. at TP		I.F.T. T <sub>303</sub> ~T <sub>305</sub>	Best IF wave form
2.	O.S.C.	AM-generator 535kHz 400Hz 30% Modulation	Antenna terminals	Oscilloscope and V.T.V.M. at output load	535kHz	O.S.C. Coil T <sub>302</sub>	Maximum
3.	O.S.C.	AM-generator 1600kHz 400Hz 30% Modulation	Antenna terminals	Oscilloscope and V.T.V.M. at output load	1600kHz	O.S.C. Trimmer cap. TC <sub>002</sub>	Maximum
4.	Repeat 2 and 3						
5.	RF amp.	AM-generator 600kHz 400Hz 30% Modulation	Antenna terminals	Oscilloscope and V.T.V.M. at output load	600kHz	RF transformer T <sub>301</sub>	Maximum
6.	Antenna circuit	AM-generator 600kHz 400Hz 30% Modulation	Antenna terminals	Oscilloscope and V.T.V.M. at output load	600kHz	Ferrite bar Antenna coil L <sub>003</sub>	Maximum
7.	RF amp.	AM-generator 1400kHz 400Hz 30% Modulation	Antenna terminals	Oscilloscope and V.T.V.M. at output load	1400kHz	RF Trimmer TC <sub>003</sub>	Maximum
8.	Antenna circuit	AM-generator 1400kHz 400Hz 30% Modulation	Antenna terminals	Oscilloscope and V.T.V.M. at output load	1400kHz	Antenna circuit Trimmer TC <sub>001</sub>	Maximum
9.	Repeat 5, 6, 7, 8						

### AM IF WAVE FORM

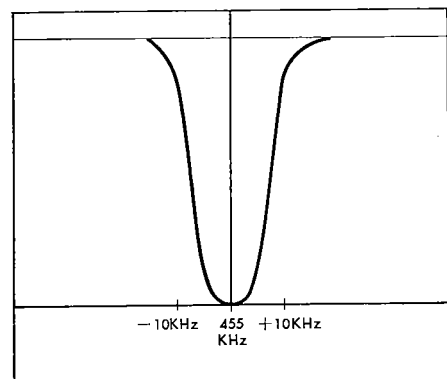

# CURRENT ADJUSTMENT

STEP	SETTING OF AMMETER (TESTER)	WHAT TO DO	NOTE
1.		Remove F <sub>002</sub> and F <sub>003</sub>	Use an ammeter with 100mA range
2.		Set VR <sub>802</sub> (left and right channel) to minimum	
3.		Set Volume Control to minimum	
4.		Turn on the receiver	Be sure to switch on 1st and then connect the ammeter
5.	100mA range.	Connect ammeter to F <sub>002</sub> as illustrated in Fig. 1	
6.		Turn VR <sub>802</sub> (left channel) clockwise and adjust current to 30 to 25 mA	
7.	100mA range.	Turn off the receiver and replace F <sub>002</sub>	
8.		Turn on the receiver and connect ammeter to F <sub>003</sub> as illustrated in Fig. 1	
9.		Turn VR <sub>802</sub> (right channel) clockwise and adjust current to 30 to 25mA	
10.		Replace F <sub>003</sub>	
11.		Adjust the rear channels as above	

# OUTPUT ADJUSTMENT

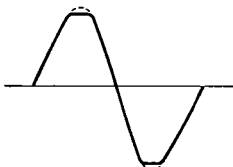
STEP	WHAT TO DO	NOTE
1.	Adjust volume control to minimum	
2.	Set oscillator to 1,000Hz and connect it to 4CH. AUX LEFT FRONT input	Oscillator used should have oscillation frequency of 20 to 20,000Hz and output voltage of more than 200mV
3.	Set Selector switch to AUX (4CH)	Set other controls and switches as follows:  Balance to CENTER Tape Monitor to OFF Mode to NORMAL Tone to CENTER Other to OFF
4.	Connect 8- or 16-ohm load resistor with capacity of more than 40 watts to LEFT SPEAKER output	
5.	Connect oscilloscope to SPEAKER terminal	
6.	Turn on the receiver and slowly raise volume. Check output at terminal by means of oscilloscope	
7.	Adjust VR <sub>801</sub> (left channel) so that peak of sine wave is clipped simultaneously	
8.	Adjust right channel similarly, and then rear channels	

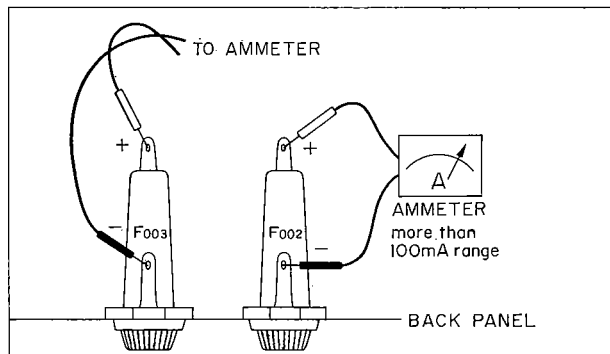

(Fig. 1) QUICK-ACTING FUSE HOLDER

# PRINTED CIRCUIT BOARDS AND PARTS LIST

W: Parts No. X: Paets Name Y: Stock No. Z: Position of Parts

## FM IF BLOCK <F-1243B>

W	X	Y	Z
R201	220Ω	0100221	2 C
R202	15kΩ	0100153	2 C
R203	4.7kΩ	0100472	2 C
R204	1kΩ	0100102	2 C
R205	390Ω	0101391	2 C
R206	680Ω	0101681	2 C
R207	3.3kΩ	0100332	2 C
R208	1.5kΩ	0100152	2 C
R209	220Ω	0100221	2 C
R210	1kΩ	0100102	2 C
R211	390Ω	0100391	2 C
R212	680Ω	0101681	2 C
R213	3.3kΩ	0100332	2 B
R214	1.5kΩ	0100152	2 B
R215	220Ω	0100221	2 B
R216	1kΩ	0100102	2 B
R217	390Ω	0100391	2 B
R218	680Ω	0101681	2 B
R219	270Ω	0101271	2 B
R220	56Ω	0100560	2 B
R221	270Ω	0101271	2 A
R222	1kΩ	0101102	2 A
R223	1kΩ	0101102	2 A
R224	270kΩ	0100274	1 C
R225	100Ω	0101101	1, 2 C
R226	1.5kΩ	0101152	1 C
R227	330Ω	0100331	1 C
R228	10kΩ	0101103	1 C
R229	1.5kΩ	0100152	1 C
R230	680Ω	0101681	1, 2 C
R231	680Ω	0101681	1, 2 B
R232	22kΩ	0100223	1 B
R233	68Ω	0100680	1 B
R234	2.2kΩ	0100222	1 B
R235	1.2kΩ	0100122	1 B
R236	560Ω	0100561	1 B
R237	100Ω	0101101	1, 2 B
R238	4.7kΩ	0101472	1 B
R239	1kΩ	0101102	1, 2 A
R240	100Ω	0101101	2 A
R241	1kΩ	0101102	1, 2 A
R242	1MΩ	0101105	1 A
R243	1MΩ	0101105	1 A
R244	4.7kΩ	0101472	1 A
R245	15kΩ	0101153	2 A
R246	12kΩ	0101123	2 A
R247	680kΩ	0101684	
R256	47Ω	0100470	1 C
R257	82Ω	0101820	
VR201	22kΩ (B)	1035150	1 A
VR202	47kΩ (B)	1035170	1 A
C201	0.022μF	0656223	2 C
C202	0.022μF	0656223	2 C
C203	0.022μF	0656223	1 C
C204	0.022μF	0656223	2 C

±10% 1/4W CR.

W	X	Y	Z
C205	0.022μF	0656223	2 C
C206	0.022μF	0656223	2 B
C207	0.022μF	0656223	2 B
C209	0.022μF	0656223	2 B
C210	0.022μF	0656223	2 B
C211	0.022μF	0656223	2 B
C212	0.039μF	0656393	2 A
C213	220pF	0660221	2 A
C214	220pF	0660221	2 A
C215	10μF	0513100	1 A
C216	0.022μF	0656223	1 C
C217	47pF	0660470	1 C
C218	0.022μF	0656223	1 C
C219	47pF	0660470	1 C
C220	22pF	0660220	2 C
C221	22pF	0660220	1 B
C222	0.022μF	0656223	1 B
C223	0.022μF	0656223	1 B
C224	22pF	0660220	1 B
C225	0.022μF	0656223	1 B
C226	0.022μF	0656223	1 B
C228	0.022μF	0656223	1 A
C229	0.022μF	0656223	1 A
C230	47μF	0512470	1 A
C231	220pF	0660221	2 A
C232	0.33μF	0601338	2 A
C233	10μF	0513100	1 A
C234	0.022μF	0656223	1 A
C235	0.022μF	0656223	
TR201		0305791	2 C
TR202		0305791	2 C
TR203		0305791	2 B
TR204		0305791	1 C
TR205		0305791	1 B
TR206		0305791	1 B
TR207		0370060, 1	1 A
D201		0310331	1 C
D202		0310331	1 C
D203		0310331	1 B
D204		0310331	1 B
IC201		0360020	2 A, B
T201	Discriminating Transformer	4235650	2 A
T202	Meter Coil	4235660	1 B
CF201		0910100, 1	2 C
CF202		0910100, 1	2 C
CF203		0910100, 1	2 C
CF204		0910100, 1	2 B
CF205		0910100, 1	2 B
CF206		0910100, 1	2 B
L202		4900100	2 C
L203		4900100	2 C

2SC930 (D)

2SK24 (E, F) FET

IN60

Ceramic Filter SFA 10.7 MC

Micro Inductor 3.3μH

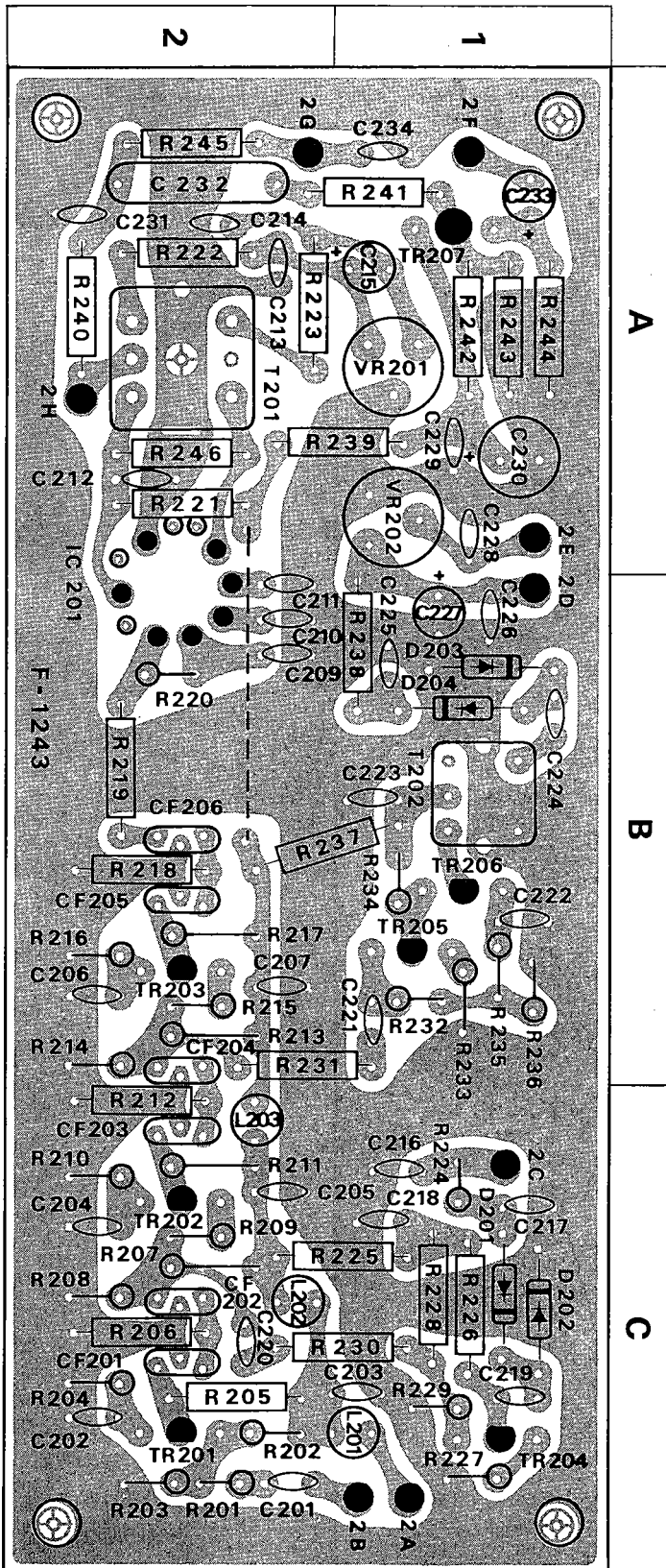

# PRINTED CIRCUIT BOARDS AND PARTS LIST

W: Parts No. X: Parts Name Y: Stock No. Z: Position of Parts

## FM MPX BLOCK <F-1322C>

W	X	Y	Z
R401	1k $\Omega$	0100102	1 C
R402	1k $\Omega$	0100102	1 C
R403	100k $\Omega$	0100104	1 C
R404	22k $\Omega$	0100223	1 C
R405	100k $\Omega$	0101104	2 A
R406	82k $\Omega$	0100823	1 C
R407	6.8k $\Omega$	0100682	2 C
R408	1.2k $\Omega$	0100122	1 C
R409	47k $\Omega$	0101473	2 C
R410	22k $\Omega$	0100223	2 C
R411	100 $\Omega$	0101101	2, 3 B
R412	1.5k $\Omega$	0100152	2, 3 B
R413	33k $\Omega$	0100333	2 B
R414	220k $\Omega$	0100224	1 A
R415	10k $\Omega$	0100103	1 A
R416	10k $\Omega$	0100103	1 A
R417	220k $\Omega$	0100224	2 A
R418	220k $\Omega$	0100224	1 A
R419	10k $\Omega$	0100103	1 A
R420	10k $\Omega$	0100103	1 A
R421	220k $\Omega$	0100224	1 A
R422	56k $\Omega$	0100563	2 A
R423	56k $\Omega$	0100563	1 A
R426	10k $\Omega$	0100103	2 A
R427	10k $\Omega$	0100103	1 A
R428	100k $\Omega$	0100104	2 A
R429	100k $\Omega$	0100104	1 A
R430	33k $\Omega$	0100333	2 A
R431	33k $\Omega$	0100333	2 A
R432	68k $\Omega$	0100683	2 A
R433	68k $\Omega$	0100683	1, 2 A
R434	4.7k $\Omega$	0100472	2 A
R435	4.7k $\Omega$	0100472	1 A
R436	100 $\Omega$	0101101	1, 2 A
R437	100k $\Omega$	0100104	2 B
R438	100k $\Omega$	0100104	2 A
R439	3.3k $\Omega$	0100332	2 A, B
R440	3.3k $\Omega$	0100332	2 A
R441	4.7k $\Omega$	0101472	2 A
R442	4.7k $\Omega$	0100472	2 A
R443	22k $\Omega$	0100223	3 A
R444	22k $\Omega$	0100223	3 A
R445	1M $\Omega$	0100105	3 C
R446	3.3k $\Omega$	0100332	2 C
R447	33 $\Omega$	0100330	2 C
R448	3.3k $\Omega$	0100332	3 C
R449	3.9k $\Omega$	0100392	3 C
R450	220k $\Omega$	0100224	3 C
R451	100k $\Omega$	0100104	3 C
R452	47k $\Omega$	0100473	3 C
R453	47 $\Omega$	0100470	3 C
R454	47k $\Omega$	0100473	3 B
R455	820 $\Omega$	0100821	3 B
R456	10k $\Omega$	0100103	2 B
R457	1k $\Omega$	0100102	3 B
R458	3.9k $\Omega$	0100392	3 B

$\pm 10\% \frac{1}{4}W$  CR.

W	X	Y	Z
R461	47k $\Omega$	0100473	3 B
R462	47k $\Omega$	0100473	2 B
R463	10k $\Omega$	0100103	2, 3 B
R464	4.7k $\Omega$	0100472	3 A
R465	47 $\Omega$	0100470	3 B
R466	220k $\Omega$	0100224	2 B
R469	150k $\Omega$	0100154	1 C
R470	100k $\Omega$	0101104	
VR401	47k $\Omega$ (B) Stereo Separation Adj.	1035170	2 A
VR402	100k $\Omega$ (B) Muting Adj.	1035190	3 C
VR403	220k $\Omega$ (B) FM Stereo Indicator Adj.	1035210	3 C
C401	68pF $\pm 10\%$ 50 V CC.	0660680	1, 2 C
C402	10 $\mu$ F 25 V EC.	0513100	1 C
C403	100pF	0620101	2 C
C404	4700pF $\pm 5\%$ 50 V SC.	0620472	2 C
C405	6800pF	0620682	1 C
C406	1 $\mu$ F 50 V EC.	0515109	2, 3 B
C407	10 $\mu$ F 25 V EC.	0513100	1 B
C408	560pF $\pm 5\%$ 50 V SC.	0620561	1 A
C409	560pF $\pm 5\%$ 50 V SC.	0620561	1 A
C410	0.15 $\mu$ F $\pm 10\%$ 50 V MC.	0601158	1 A
C411	0.15 $\mu$ F	0601158	1 A
C412	1500pF $\pm 5\%$ 50 V SC.	0620152	2 A
C413	1500pF	0620152	1 A
C416	10 $\mu$ F 25 V EC.	0513100	2 A
C417	10 $\mu$ F	0513100	1 A
C418	560pF $\pm 5\%$ 50 V SC.	0620561	2 A
C419	1 $\mu$ F 50 V EC.	0515109	2 A
C420	1 $\mu$ F	0515109	2 A
C421	0.0022 $\mu$ F	0600226	2 A
C422	0.0022 $\mu$ F	0600226	2 A
C423	0.0022 $\mu$ F $\pm 5\%$ 50 V MC.	0600226	3 A
C424	0.0022 $\mu$ F	0600226	3 A
C425	0.0022 $\mu$ F	0600226	3 A
C426	0.0022 $\mu$ F	0600226	3 A
C427	0.022 $\mu$ F $^{+80}_{-20}\%$ 50 V CC.	0656223	3 C
C428	0.68 $\mu$ F 25 V AEC.	0563688	3 C
C429	10 $\mu$ F 25 V EC.	0513100	2 B
C433	47 $\mu$ F 25 V EC.	0513470	2 B, C
C434	1 $\mu$ F 50 V EC.	0515109	2 B
C493	100 $\mu$ F 25 V EC.	0513101	
C494	0.022 $\mu$ F $^{+80}_{-20}\%$ 50 V CC.	0657222	
C495	0.1 $\mu$ F	0563108	
C496	0.68 $\mu$ F 25 V AEC.	0563688	
TR401	2SC871 (F)	0305472	1 C
TR402	2SA562 (Y)	0300221	2 B
TR403		0305472	2 A
TR404		0305472	1 A
TR405	2SC871 (F)	0305472	1 A, B
TR406		0305472	1 A
TR407	2SC733 (O, Y)	0305370, 1	3 A
TR408		0305370, 1	3 A
TR409	2SC711 (E, F)	0305731, 2	2 C
TR410		0305370, 1	3 C
TR411	2SC733 (O, Y)	0305370, 1	3 B, C



W	X	Y	Z
TR412	2SC711 (G)	0305733	3 B
TR413	2SC711 (E, F)	0305731, 2	3 B
TR414	2SC735 (O, Y)	0305640, 1	3 B
TR415	2SA678 (5, 6)	0300290, 1	3 B
TR416	2SC711 (E, F)	0305731, 2	3 B
TR417	2SC711 (D, E)	0305730, 1	
D401	} IN34A	0310400	2 C
D402		0310400	2 C
D403		0310401	1, 2 B
D404	} IN34A (Y)	0310401	1, 2 B
D405		0310401	1 B

W	X	Y	Z
D406	} IN34A	0310401	1 B
D407		0310400	3 C
D491		10D-1	0310340
L401	MPX Coil	4240510	1 C
L402	2.2mH Micro Inductor	4900090	2 C
L403	1mH	4900120	2 C
L404	} MPX Coil	4240400	3 A
L405		4240400	3 A
LC401	} MPX Coil	4240490	1, 2 B, C
LC402		4240500	1 B

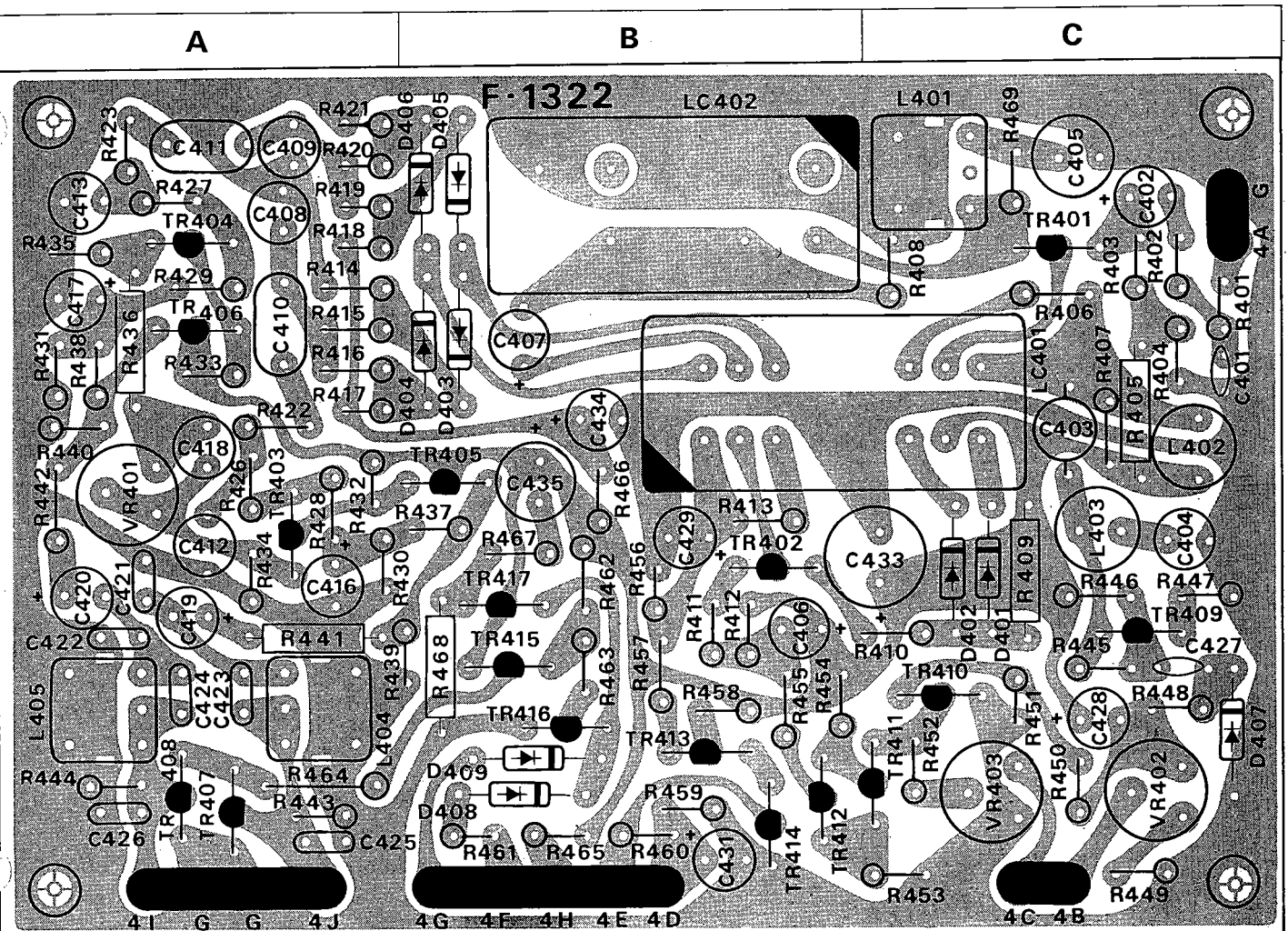

# PRINTED CIRCUIT BOARDS AND PARTS LIST

W: Parts No. X: Parts Name Y: Stock No. Z: Position of Parts

## AM BLOCK <F-1038-4B>

W	X	Y	Z
R301	10kΩ	0101103	1, 2 C
R302	39Ω	0101390	1 C
R303	1kΩ	0101102	2 C
R304	100Ω	0101101	1 C
R305	3.9kΩ	0101392	2 C
R306	33kΩ	0101333	1 C
R307	22Ω	0101220	1, 2 B
R308	1kΩ	0101102	2 B
R309	100Ω	0101101	1 C
R310	22kΩ	0101223	2 B, C
R311	3.9kΩ	0101392	1 B
R312	1kΩ	0101102	2 B
R313	10Ω	0101100	2 B, C
R314	22Ω	0101220	1 B
R315	47kΩ	0101473	1 A
R316	10kΩ	0101103	2 B
R317	47kΩ	0101473	1 B
R318	100Ω	0101101	1 B
R319	22Ω	0101220	2 B
R320	1kΩ	0101102	2 B
R322	100Ω	0101101	1 B
R323	6.8kΩ	0101682	2 B
R324	100kΩ	0101104	2 A, B
R325	100kΩ	0101104	2 A, B
R326	22kΩ	0101223	2 A
R327	2.2kΩ	0101222	2 B
R328	22Ω	0101220	1 A, B
R329	4.7kΩ	0101472	1 A, B
R330	22kΩ	0101223	1 A
R331	470Ω	0101471	1 A
R332	4.7kΩ	0101472	2 A
R333	470Ω	0101471	1 A
R334	470Ω	0101471	1 A
R335	1kΩ	0101102	2 A
R336	100Ω	0101101	2 A
R337	4.7kΩ	0101472	2 A
VR301	10kΩ (B) AM Meter Adj.	1035130	1, 2 A
C301	0.022μF } +80% 25 V CC.	0656223	1 C
C302	0.039μF } -20%	0656393	2 C
C303	1μF 50 V EC.	0515109	2 C
C304	0.022μF } 0656223	0656223	2 C
C305	0.039μF } 0656393	0656393	1 C
C306	0.039μF } +80% 25 V CC.	0656393	2 C
C307	0.039μF } -22%	0656393	1 C
C308	0.022μF } 0656223	0656223	1 B
C309	0.01μF } ±10% 50 V MC.	0601107	2 B
C310	0.01μF } 0601107	0601107	2 B
C311	22pF ±10% 50 V CC.	0660220	2 C
C312	430pF ±5% 50 V MiC.	0640431	2 C
C313	0.022μF } +80% 25 V CC.	0656223	1 C
C314	4.7μF } -20%	0512479	2 B
C315	0.022μF } 0656223	0656223	2 B
C316	0.022μF } 0656223	0656223	1 B
C317	0.039μF } +80% 25 V CC.	0656393	2 B
C318	0.022μF } -20%	0656223	1 B

W	X	Y	Z
C319	33μF 16 V EC.	0512330	2 B
C320	0.02μF ±10% 50 V MC.	0601207	2 A
C321	1μF 50 V EC.	0515109	2 B
C322	0.02μF ±10% 50 V MC.	0601207	2 A
C323	0.039μF } 0656393	0656393	2 B
C324	0.039μF } 0656393	0656393	2 A
C325	0.022μF } +80% 25 V CC.	0656223	1 A
C326	0.022μF } -20%	0656223	1 A
C327	0.022μF } 0656223	0656223	1 A
C329	0.012μF } ±10% 50 V MC.	0601127	2 A
C330	0.015μF } 0601157	0601157	2 A
C332	0.022μF } +80% 25 V CC.	0656223	1 B
C333	0.039μF } -20%	0656393	2 A
C334	33μF 16 V EC.	0512330	1 C
TR301	} 2SC380 (O)	0305331	1 C
TR302		0305331	1 C
TR303		0305331	2 B
TR304	} 2SC380 (R)	0305330	1, 2 B
TR305		0305330	1 A
TR306		0305320	2 A
TR306	2SC458L (C)	0305320	2 A
D301	IN60	0310330	1, 2 C
D302	} DS-410	0340030	1 C
D303		0340030	2 B
D304		0310330	1, 2 A
D305	} IN60	0310330	1 A
D306		0310330	1 A
T301	AM RFT	4210100	1 C
T302	AM OSC Coil	4220300	2 C
T303	Ceramic Filter	4230440	1 B
T304	} AM IFT 455KHz	4230480	1 B
T305		4230470	1 A

# LAMP HOLDER BLOCK <F-1374>

W	X	Y
R041	18Ω ±10% ¼W CR.	0101180
PL005		0420020
PL006		0420020
PL007	6.3V 0.25A Pilot Lamp	0420020
PL008		0420020
PL009		0420020

# SWITCH BLOCK <F-1376>

W	X	Y
S8(a, b) (or S9(a, b))	Front (or Rear) High Filter Switch	1130380
S10(a, b) (or S11(a, b))	Front (or Rear) Low Filter Switch	1130380

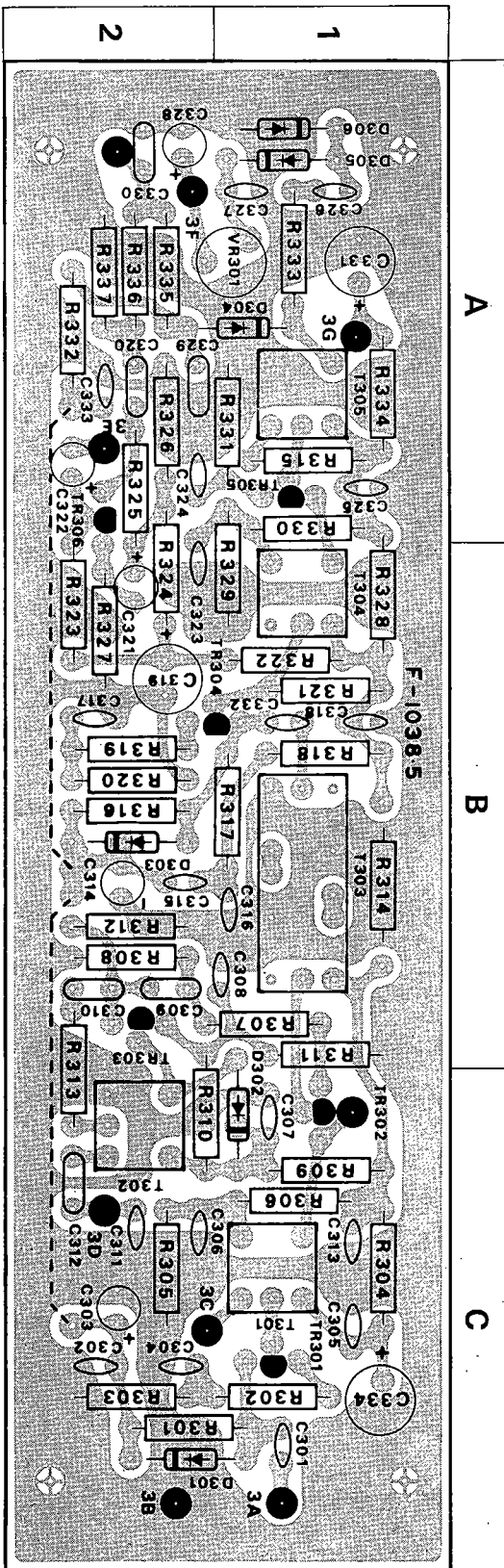

## Abbreviations

- CR** : Carbon Resistor
- SR** : Solid Resistor
- CeR** : Cement Resistor
- MC** : Mylar Capacitor
- EC** : Electrolytic Capacitor
- AEC** : Aluminum Solid Electrolytic Capacitor
- CC** : Ceramic Capacitor
- MIC** : Mica Capacitor
- SC** : Styrol Capacitor
- OC** : Oil Capacitor

# PRINTED CIRCUIT BOARDS AND PARTS LIST

W: Parts No. X: Parts Name Y: Stock No. Z: Position of Parts

## EQUALIZER BLOCK <F-1267B>

W	X	Y	Z
R601	2.2kΩ	0101222	2 B
R602	2.2kΩ	0101222	2 A
R603	56kΩ	0101563	2 B
R604	56kΩ	0101563	2 A
R605	390kΩ	0101394	2 B
R606	390kΩ	0101394	2 A
R607	3.9kΩ	0101392	2 B
R608	3.9kΩ	0101392	2 A
R609	390Ω	0101391	1 B
R610	390Ω	0101391	1 A
R611	180kΩ	0101184	1 B
R612	180kΩ	0101184	1 A
R613	820Ω	0101821	1 B
R614	820Ω	0101821	1 A
R615	6.8kΩ	0101682	1 B
R616	6.8kΩ	0101682	1 A
R617	82kΩ	0101823	2 B
R618	82kΩ	0101823	2 A
R619	270kΩ	0101274	1 B
R620	270kΩ	0101274	1 A
R621	1.5kΩ	0101152	1 B
R622	1.5kΩ	0101152	1 A
R623	22kΩ	0101223	1 B
R624	22kΩ	0101223	1 A

±10% ¼W CR.

W	X	Y	Z		
C601	0.47 μF	±10% 50V MC.	0601478	2 B	
C602	0.47 μF		0601478	2 A	
C603	68pF	±10% 50 V CC.	0660680	2 B	
C604	68pF		0660680	2 A	
C605	68pF		0660680	1 B	
C606	68pF		0660680	1 A	
C607	3.3 μF		25 V EC.	0513339	2 B
C608	3.3 μF			0513339	2 A
C609	100 μF	6.3 V EC.	0510101	2 B	
C610	100 μF		0510101	2 A	
C611	1 μF	50 V EC.	0515109	1 B	
C612	1 μF		0515109	1 A	
C613	0.012 μF		0601127	1 B	
C614	0.012 μF		0601127	1 A	
C615	0.003 μF	±10% 50 V MC.	0601306	1 B	
C616	0.003 μF		0601306	1 A	
C617	0.047 μF		0601477	1 B	
C618	0.047 μF		0601477	1 A	
TR601	2SC871R (E)	0305474	2 B		
TR602		0305474	2 B		
TR603	2SC871R (F)	0305475	2 B		
TR604		0305475	2 B		

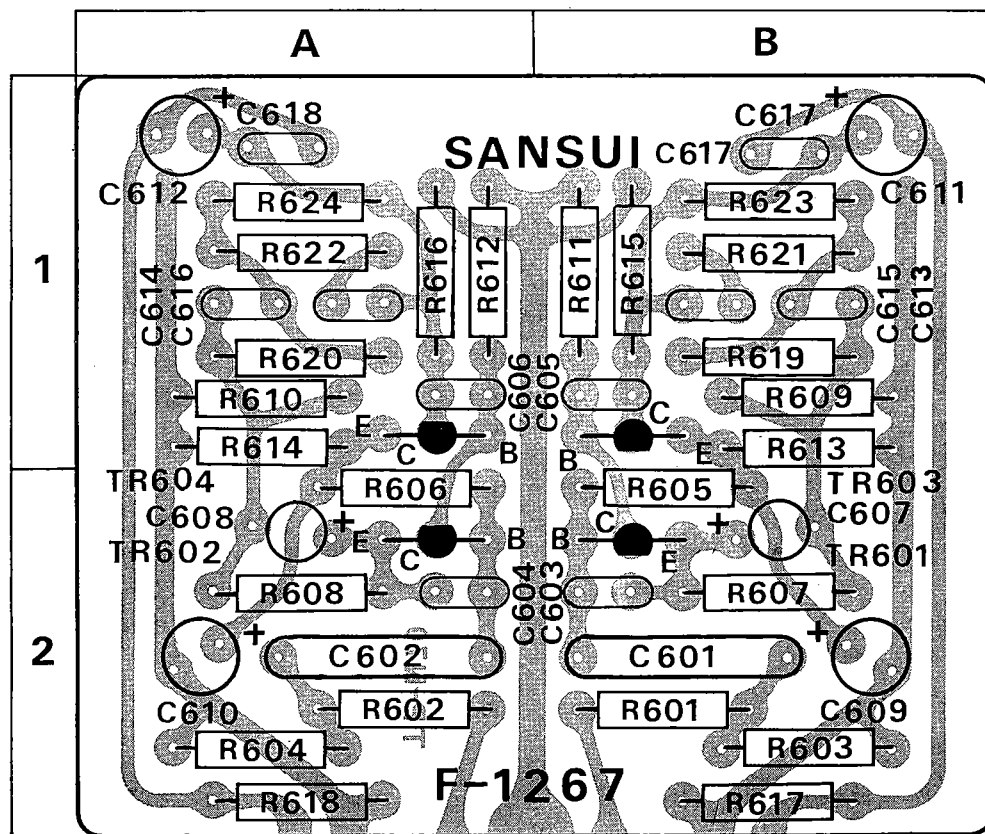

# SYNTHESIZER BLOCK <F-1371>

W	X	Y	Z
R901	1kΩ	0101102	2C
R902	1kΩ	0101102	1C
R903	150kΩ	0101154	2C
R904	150kΩ	0101154	1C
R905	100kΩ	0101104	2C
R906	100kΩ	0101104	1C
R907	6.8kΩ	0101682	2C
R908	6.8kΩ	0101682	1C
R909	5.6kΩ	0101562	1B
R910	5.6kΩ	0101562	2B
R913	56kΩ	0101563	2C
R914	56kΩ	0101563	1C
R915	18kΩ	0101183	2C
R916	18kΩ	0101183	1C
R917	10kΩ	0101103	2C
R918	10kΩ	0101103	1C
R919	8.2kΩ	0101822	2C
R920	8.2kΩ	0101822	1C
R921	100kΩ	0101104	2C
R922	100kΩ	0101104	1C
R923	4.7kΩ	0101472	2C
R924	4.7kΩ	0101472	1C
R925	15kΩ	0101153	1, 2C
R926	15kΩ	0101153	1, 2C
R927	1MΩ	0101105	1B
R928	1MΩ	0101105	2B
R929	56kΩ	0101563	1B
R930	56kΩ	0101563	2B

±10% ¼W CR.

W	X	Y	Z
R931	1.5kΩ	0101152	1B, C
R932	1.5kΩ	0101152	2B, C
R933	470Ω	0101471	1B
R934	470Ω	0101471	2B
R935	22kΩ	0101223	1B
R936	22kΩ	0101223	2B
R937	100kΩ	0101104	1B
R938	100kΩ	0101104	2B
R939	68kΩ	0101683	1B
R940	68kΩ	0101683	2B
R941	100kΩ	0101104	1B
R942	100kΩ	0101104	2B
R943	4.7Ω	0101479	1B
R944	4.7Ω	0101479	2B
R945	15kΩ	0101153	1B
R946	15kΩ	0101153	2B
R947	39kΩ	0101393	1A
R948	39kΩ	0101393	2A
R949	560kΩ	0101564	1A
R950	560kΩ	0101564	2A
R951	470Ω	0101471	1, 2C
R953	560Ω	0101220	1A
R954	560Ω	0101220	2A
R961	470kΩ	0101474	
R962	470kΩ	0101474	
R963	820kΩ	0101824	
R964	820kΩ	0101824	

±10% ¼W CR.

VR901	2kΩ(B)	1032070	1B
-------	--------	---------	----

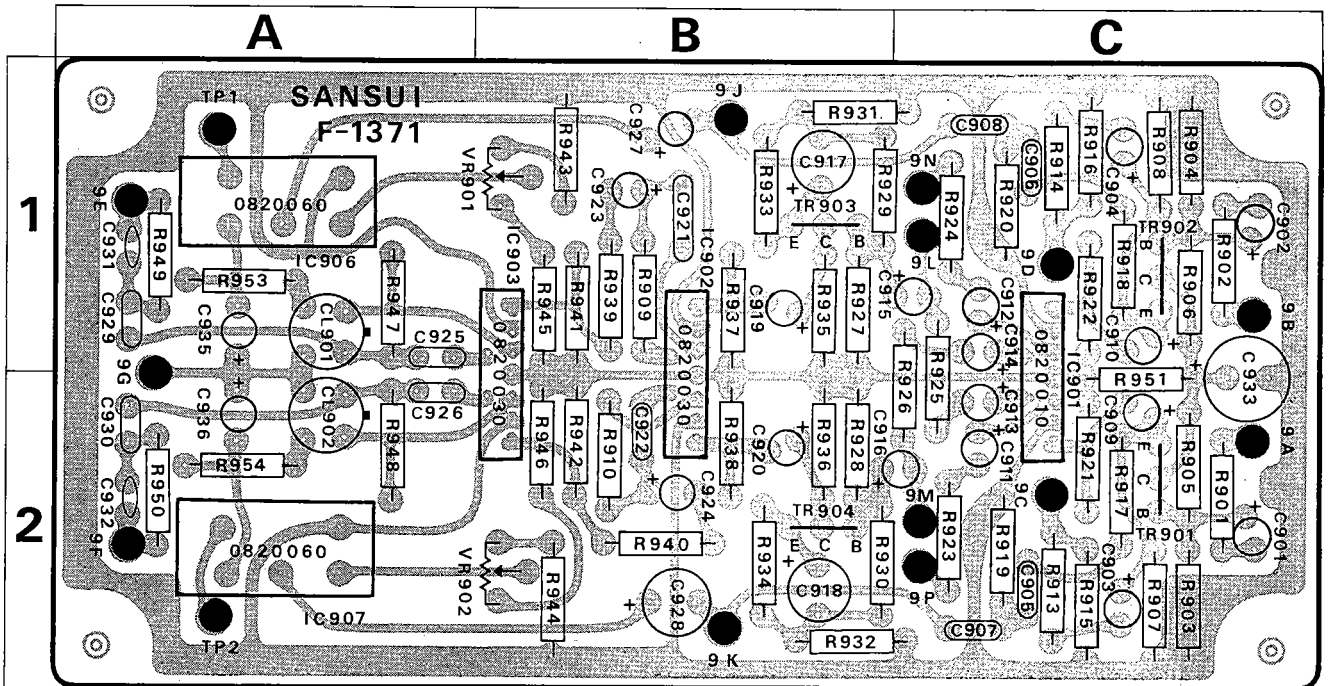

# PRINTED CIRCUIT BOARDS AND PARTS LIST

W: Parts No. X: Parts Name Y: Stock No. Z: Position of Parts

## SYNTHESIZER BLOCK <F-1371> cont'd

W	X	Y	Z
VR902	2kΩ(B)	1032070	2 B
C901	0.47μF	0563478	2 C
C902	0.47μF	0563478	1 C
C903	0.68μF	0563688	2 C
C904	0.68μF	0563688	1 C
C905	0.047μF	0601477	2 C
C906	0.047μF	0601477	1 C
C907	0.047μF	0601477	2 C
C908	0.047μF	0601477	1 C
C909	1μF	0515109	2 C
C910	1μF	0515109	1 C
C911	1μF	0515109	2 C
C912	1μF	0515109	1 C
C913	1μF	0515109	1 C
C914	1μF	0515109	1 C
C915	1μF	0515109	1 C
C916	1μF	0515109	2 B, C
C917	100μF	0510101	1 B
C918	100μF	0510101	2 B
C919	1μF	0515109	1 B
C920	1μF	0515109	2 B
C921	0.1μF	0601108	1 B
C922	0.047μF	0601477	2 B
C923	1μF	0515109	1 B
C924	1μF	0515109	2 B
C925	0.0033μF	0601336	1 A
C926	0.0033μF	0601336	2 A
C927	1μF	0515109	1 B
C928	1μF	0515109	2 B
C929	0.047μF	0601477	1 A
C930	0.047μF	0601477	2 A
C931	12pF	0660120	1 A
C932	12pF	0660120	2 A
C933	100μF	0513101	1, 2 C
TR901	2SC458LG (B, C)	0305313, 4	2 C
TR902		0305313, 4	1 C
TR903		0305313, 4	1 B
TR904		0305313, 4	2 B
IC901	Hybrid IC	0820011	1, 2 C
IC902		0820031	1, 2 B
IC903		0820031	1, 2 B
IC906		0820070	1 A
IC907		0820070	2 A
CL901	MTL-756A	0920030,31,40	1 A
CL902		0920030,31,40	2 A

## PHASE MODULATOR BLOCK <F-1372>

W	X	Y	Z
R641	1kΩ	0100102	1 A
R642	1kΩ	0100102	1 B
R643	1kΩ	0100102	1, 2 A
R644	1kΩ	0100102	1, 2 B
R645	120kΩ	0100124	1 A
R646	120kΩ	0100124	1 B
R647	120kΩ	0100124	2 A
R648	120kΩ	0100124	2 B
R649	39kΩ	0100393	1 A
R650	39kΩ	0100393	1 B
R651	39kΩ	0100393	2 A
R652	39kΩ	0100393	2 B
R653	2.2kΩ	0100222	1 A
R654	2.2kΩ	0100222	1 B
R655	2.2kΩ	0100222	2 A
R656	2.2kΩ	0100222	2 B
R657	100kΩ	0100104	1 A
R658	100kΩ	0100104	1 B
R659	100kΩ	0100104	1 A
R660	100kΩ	0100104	1, 2 B
R661	1kΩ	0100102	1 A
R662	1kΩ	0100102	1 B
R663	1.5kΩ	0100152	2 A
R664	1.5kΩ	0100152	2 B
R665	68kΩ	0100683	1 A
R666	68kΩ	0100683	1 B
R667	68kΩ	0100683	2 A
R668	68kΩ	0100683	2 B
R669	820Ω	0100821	1 A
R670	820Ω	0100821	1 B
R671	820Ω	0100821	2 A
R672	820Ω	0100821	2 B
R673	6.8kΩ	0100682	1 A
R674	6.8kΩ	0100682	1 B
R675	6.8kΩ	0100682	1 A
R676	6.8kΩ	0100682	1 B
R677	10kΩ	0100103	1 A
R678	10kΩ	0100103	1 B
R679	10kΩ	0100103	2 A
R680	10kΩ	0100103	2 B
R952	18kΩ	0101183	1 C
R953	39kΩ	0101393	1 C
R954	33kΩ	0101333	1 C
R955	33kΩ	0101333	1 C
R956	150kΩ	0101154	1 C
R957	120kΩ	0101124	1 C
VR941	47kΩ (B)	1035170	1 C
VR942		1035170	1 C
VR943		1035170	1 C
C641	1.5μF	0579003	1 A
C642	1.5μF	0579003	1 B
C643	1.5μF	0579003	1 A
C644	1.5μF	0579003	1 B
C645	33μF	0510330	1 A
C646	33μF	0510330	1 B

W	X	Y	Z	
C647	100 $\mu$ F	6.3 V EC.	0510101 2 A	
C648	100 $\mu$ F		0510101 2 B	
C649	100 $\mu$ F		0510101 1 A	
C650	100 $\mu$ F		0510101 1 B	
C651	100 $\mu$ F		0510101 2 A	
C652	100 $\mu$ F		0510101 2 B	
C653	10 $\mu$ F		0513100 1 A	
C654	10 $\mu$ F		0513100 1 B	
C655	10 $\mu$ F		0513100 2 A	
C656	10 $\mu$ F		0513100 1 B	
C657	47 pF	25 V EC.	0660470 1 A	
C658	47 pF		0660470 1 B	
C659	100 pF		$\pm 10\%$ 50 V CC.	0660101 2 A
C650	100 pF		0660101	
C933	100 $\mu$ F		0510101 1 C	
C934	100 $\mu$ F	0510101 1 C		
C935	100 $\mu$ F	0510101 1 C		
TR641	2SC871R (F)	0305475	1 A	
TR642		0305475	1 B	
TR643		0305475	1, 2 A	
TR644		0305475	1, 2 B	
TR645		0305475	1 A	
TR646		0305475	1 B	
TR647		0305475	2 A	
TR648		0305475	2 B	

W	X	Y	Z
IC941	Hybrid IC	0820040	1 C
IC942		0800220	2 C
IC943		0800210	2 C
IC944		0800210	2 C

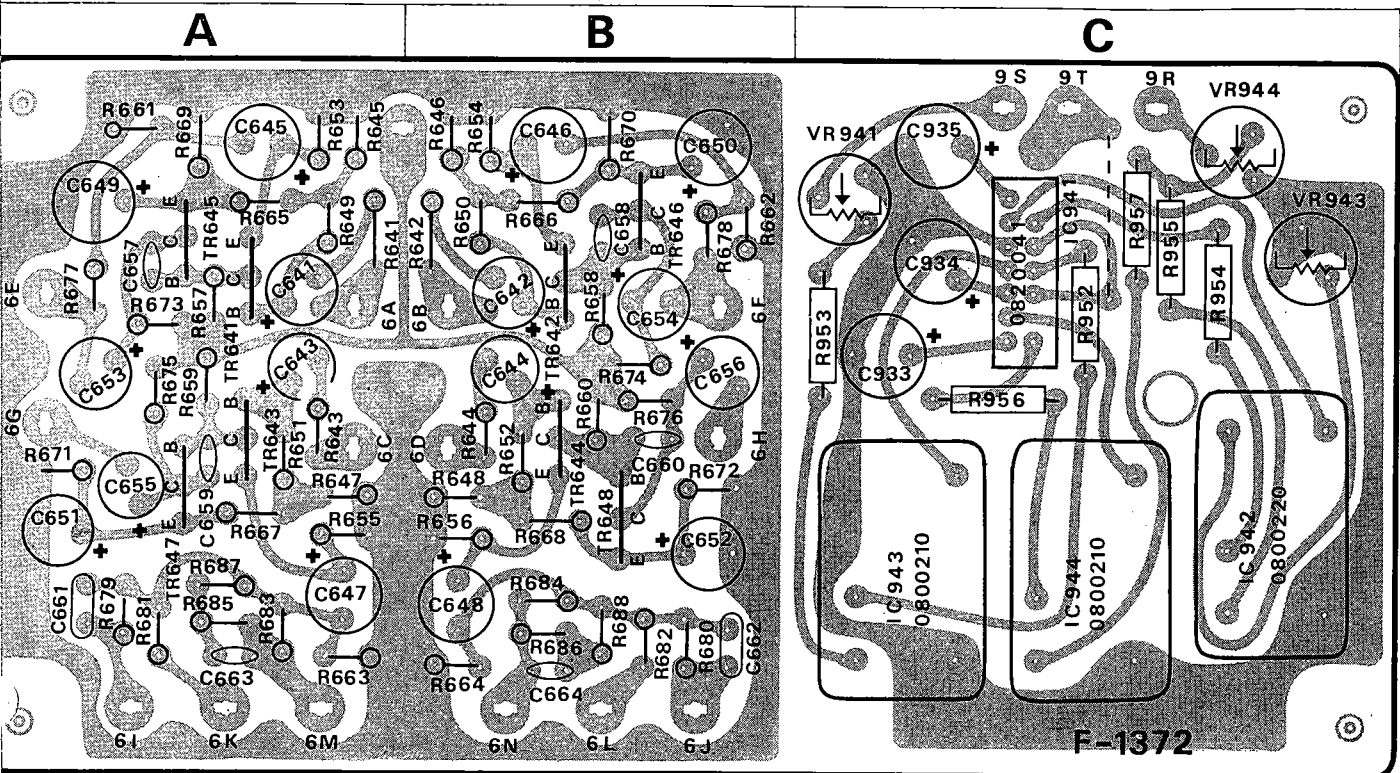

# PRINTED CIRCUIT BOARDS AND PARTS LIST

W: Parts No. X: Parts Name Y: Stock No. Z: Position of Parts

## STONE CONTROL BLOCK <F-1370>

W	X	Y	Z
R703	2.2kΩ	0101222	2C
R704	2.2kΩ	0101222	1C
R705	56kΩ	0101563	2C
R706	56kΩ	0101563	1C
R707	3.3kΩ	0101332	2C
R708	3.3kΩ	0101332	1C
R709	8.2kΩ	0101822	2C
R710	8.2kΩ	0101822	1C
R711	560kΩ	0101564	2C
R712	560kΩ	0101564	1C
R713	6.8kΩ	0101682	2C
R714	6.8kΩ	0101682	1C
R715	1.5kΩ	0101152	2B
R716	1.5kΩ	0101152	1B
R717	10kΩ	0101103	2B
R718	10kΩ	0101103	1B
R719	2.7kΩ	0101272	2B
R720	2.7kΩ	0101272	1B
R721	2.2kΩ	0101222	2B
R722	2.2kΩ	0101222	1B
R723	22kΩ	0101223	2B
R724	22kΩ	0101223	1B

±10% ¼W CR.

W	X	Y	Z
R725	6.8kΩ	0101682	2B
R726	6.8kΩ	0101682	1B
R727	10kΩ	0101103	2B
R728	10kΩ	0101103	1B
R731	1.5kΩ	0101152	2B
R732	1.5kΩ	0101152	1B
R733	180kΩ	0101184	2A
R734	180kΩ	0101184	1A
R735	10kΩ	0101103	2A
R736	10kΩ	0101103	1A
R737	2.2kΩ	0101222	2B
R738	2.2kΩ	0101222	1B
R739	3.3kΩ	0101332	2A
R740	3.3kΩ	0101332	1A
R741	1.5kΩ	0101152	2A
R742	1.5kΩ	0101152	1A
R743	100kΩ	0101104	2A
R744	100kΩ	0101104	1A
R745	100Ω	0101101	1, 2A

±10% ¼W CR.

C701	0.002μF	0601206	2C
C702	0.002μF	0601206	1C

±10% 50 V MC.

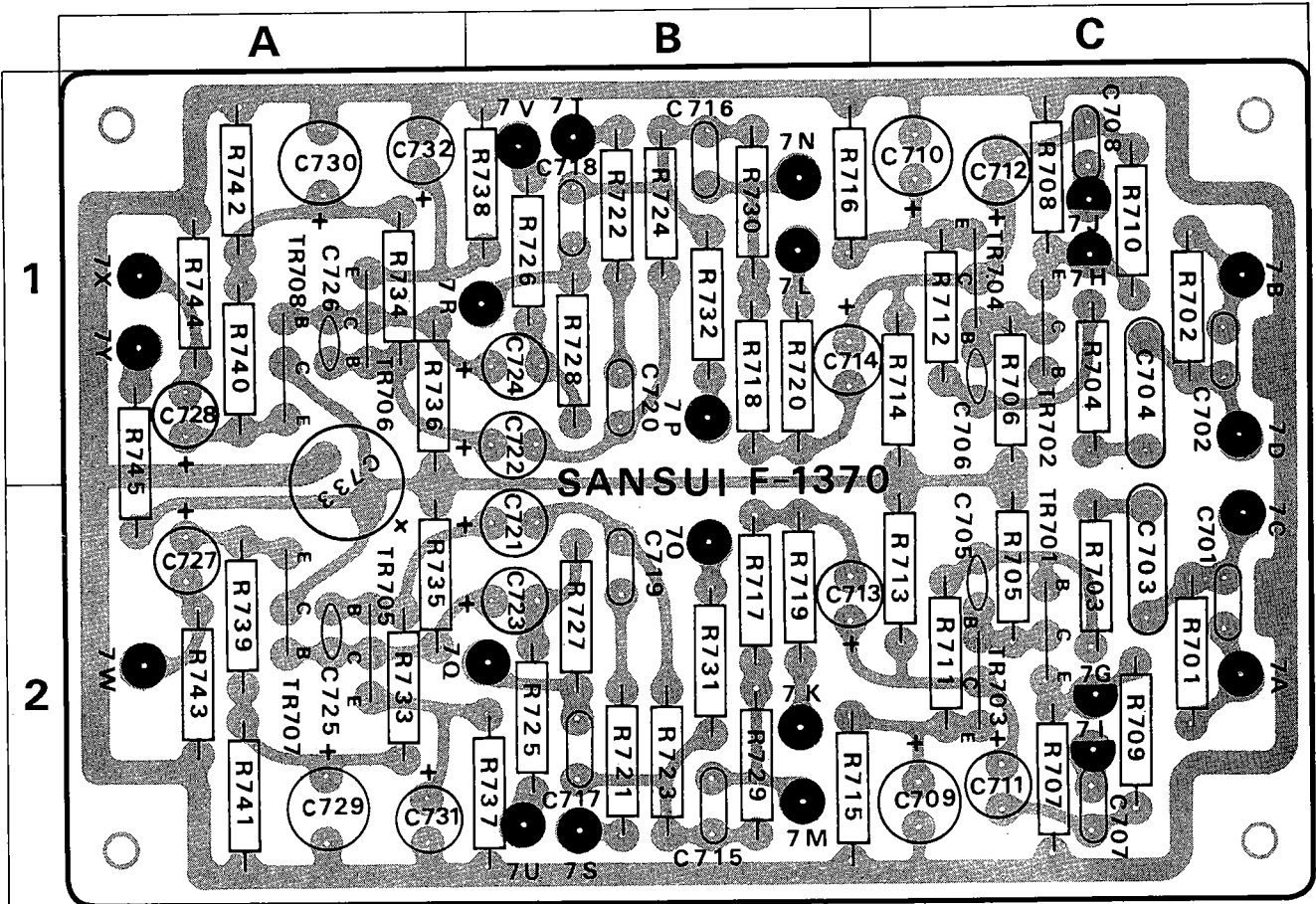



# SWITCH BLOCK <F-1375>

W	X	Y	Z
C703	0.22 $\mu$ F	0601228	2 C
C704	0.22 $\mu$ F	0601228	1 C
C705	47 pF	0660470	2 C
C706	47 pF	0660470	1 C
C707	0.012 $\mu$ F	0601127	2 C
C708	0.012 $\mu$ F	0601127	1 C
C709	47 $\mu$ F	0510470	2 C
C710	47 $\mu$ F	0510470	1 C
C711	4.7 $\mu$ F	0513479	2 C
C712	4.7 $\mu$ F	0513479	1 C
C713	4.7 $\mu$ F	0513479	2 B
C714	4.7 $\mu$ F	0513479	1 B
C715	0.033 $\mu$ F	0601337	2 B
C716	0.033 $\mu$ F	0601337	1 B
C717	0.033 $\mu$ F	0601337	2 B
C718	0.033 $\mu$ F	0601337	1 B
C719	0.0012 $\mu$ F	0601126	2 B
C720	0.0012 $\mu$ F	0601126	1 B
C721	1 $\mu$ F	0515109	2 B
C722	1 $\mu$ F	0515109	1 B
C725	47 pF	0660470	2 A
C726	47 pF	0660470	1 A
C727	4.7 $\mu$ F	0513479	2 A
C728	4.7 $\mu$ F	0513479	1 A
C729	100 $\mu$ F	0510101	2 A
C730	100 $\mu$ F	0510101	1 A
C731	47 $\mu$ F	0510470	2 A
C732	47 $\mu$ F	0510470	1 A
C733	100 $\mu$ F	0513101	1, 2 A
TR701	2SC871R (F)	0305475	2 C
TR702		0305475	1 C
TR703	2SC871 (D)	0305470	2 C
TR704		0305470	1 C
TR705	2SC871R (F)	0305475	2 A
TR706		0305475	1 A
TR707	2SC871 (D)	0305470	2 A
TR708		0305470	1 A

W	X	Y	Z
R027	27k $\Omega$	$\pm 10\%$ $\frac{1}{4}$ W CR.	0101273 1 A
R028	27k $\Omega$		0101273 1 A
R029	27k $\Omega$		0101273 1 A
R030	27k $\Omega$		0101273 1 A
C015	180 pF	$\pm 10\%$ 50 V MiC.	0641181 1 A
C016	180 pF		0641181 1 A
C017	180 pF		0641181 1 A
C018	180 pF		0641181 1 A
C019	0.01 $\mu$ F	$\pm 10\%$ 50 V MC.	0601107 1 A
C020	0.01 $\mu$ F		0601107 1 A
C021	0.01 $\mu$ F		0601107 1 A
C022	0.01 $\mu$ F		0601107 1 A
S2(a, b)	2CH-1 Tape Monitor Switch	1130390	1 B
S3(a, b)	2CH-2 Tape Monitor Switch		1 B
S4(a~d)	4CH. Tape Monitor Switch		1 B
S5	FM Muting Release Switch		1 A
S6(a, b)	Front Loudness Switch		1 A
S7(a, b)	Rear Loudness Switch		1 A

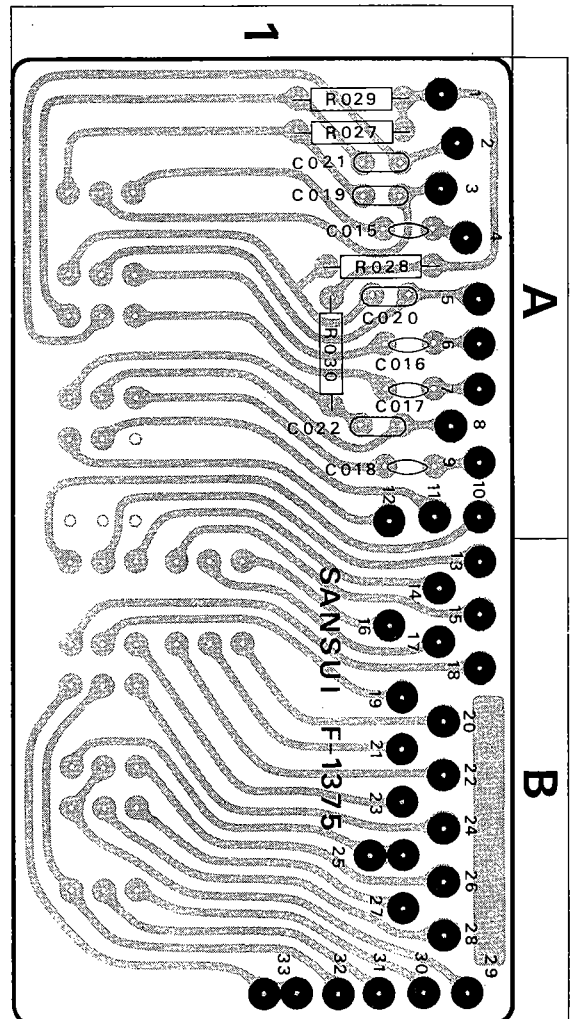

# PRINTED CIRCUIT BOARDS AND PARTS LIST

W: Parts No. X: Parts Name Y: Stock No. Z: Position of Parts

## DRIVER BLOCK <F-1180C>

W	X	Y	Z
R801	2.2k $\Omega$	0101222	1A
R802	150k $\Omega$	0101154	1A
R803	560k $\Omega$	0101564	1A
R804	680 $\Omega$	0101681	1A
R805	3.3k $\Omega$	0101332	1A
R806	3.3k $\Omega$	0101332	1A
R807	10k $\Omega$	0101103	1A
R808	47k $\Omega$	0101473	1A
R809	56k $\Omega$	0101563	1A
R810	1.8k $\Omega$	0101182	1B
R811	3.9k $\Omega$	0101392	2B
R812	39 $\Omega$	0101390	2B
R813	3.3k $\Omega$	0101332	1B
R814	1k $\Omega$	0101102	2A
R815	220 $\Omega$	0101221	2A
R816	100 $\Omega$	0101101	2B
R817	4.7 $\Omega$	0101479	2A
R818	100 $\Omega$	0101101	2A
R819	6.8 $\Omega$	0111689	2A
R820	12k $\Omega$	0101123	1A
R821	2.2k $\Omega$	0101222	1C
R822	150k $\Omega$	0101154	1C
R823	560k $\Omega$	0101564	1C
R824	680 $\Omega$	0101681	1C
R825	3.3k $\Omega$	0101332	1C
R826	3.3k $\Omega$	0101332	1C
R827	10k $\Omega$	0101103	1C
R828	47k $\Omega$	0101473	1C
R829	56k $\Omega$	0101563	1C
R830	1.8k $\Omega$	0101182	1B
R831	3.9k $\Omega$	0101392	2B
R832	39 $\Omega$	0101390	2B
R833	3.3k $\Omega$	0101332	1B
R834	1k $\Omega$	0101102	2C
R835	220 $\Omega$	0101221	2C
R836	100 $\Omega$	0101101	2B
R837	4.7 $\Omega$	0101479	2C
R838	100 $\Omega$	0101101	2C
R839	6.8 $\Omega$	0111689	2C
R840	12k $\Omega$	0101123	1C
C801	0.22 $\mu$ F $\pm 10\%$ 50 V MC.	0601228	1A
C802	100 $\mu$ F 25 V EC.	0513101	1A
C803	220 $\mu$ F 10 V EC.	0511221	1A
C804	1 $\mu$ F	0515109	1A
C805	33 $\mu$ F	0515330	1B
C806	100 $\mu$ F 10 V EC.	0511101	2A
C807	10 $\mu$ F 50 V EC.	0515100	1B
C808	0.047 $\mu$ F $\pm 10\%$ 50 V MC.	0601477	2A
C809	47pF $\pm 10\%$ 50 V CC.	0660470	1A
C811	0.22 $\mu$ F $\pm 10\%$ 50 V MC.	0601228	1C
C812	100 $\mu$ F 25 V EC.	0513101	1C
C813	220 $\mu$ F 10 V EC.	0511221	1C
C814	1 $\mu$ F	0515109	1C
C815	33 $\mu$ F	0515330	1B
C816	100 $\mu$ F 10 V EC.	0511101	2C

W	X	Y	Z
C817	10 $\mu$ F 50 V EC.	0515100	1B
C818	0.047 $\mu$ F $\pm 10\%$ 50 V MC.	0601477	2C
C819	47pF	0660470	1C
C823	22pF	0660220	2A
C834	22pF	0660220	2C
C825	330pF	0660331	2B
C826	330pF	0660331	2B
VR801	200k $\Omega$ (B) AC Balance Adjustor	1030790	1A, B
VR802	1k $\Omega$ (B) DC Bias Adjustor	1030690	2A, B
VR803	200k $\Omega$ (B) AC Balance Adjustor	1030790	1B, C
VR804	1k $\Omega$ (B) DC Bias Adjustor	1030690	2B, C
TR801	2SC458LG (B, C)	0305310, 1	1A
TR802	2SC1124 (2, 3)	0305901, 2	2A
TR803	2SC984 (B, C)	0305871, 2	2A, B
TR804	2SC485 (Y, BL)	0305261, 2	2B
TR805	2SA485 (Y, BL) Pair	0300071, 2	2A
TR806	2SC458LG (B, C)	0305310, 1	1C
TR807	2SC1124 (2, 3)	0305901, 2	2C
TR808	2SC984 (B, C)	0305871, 2	2B, C
TR809	2SC485 (Y, BL) Pair	0305261, 2	2B
TR810	2SA485 (Y, BL) Pair	0300071, 2	2C

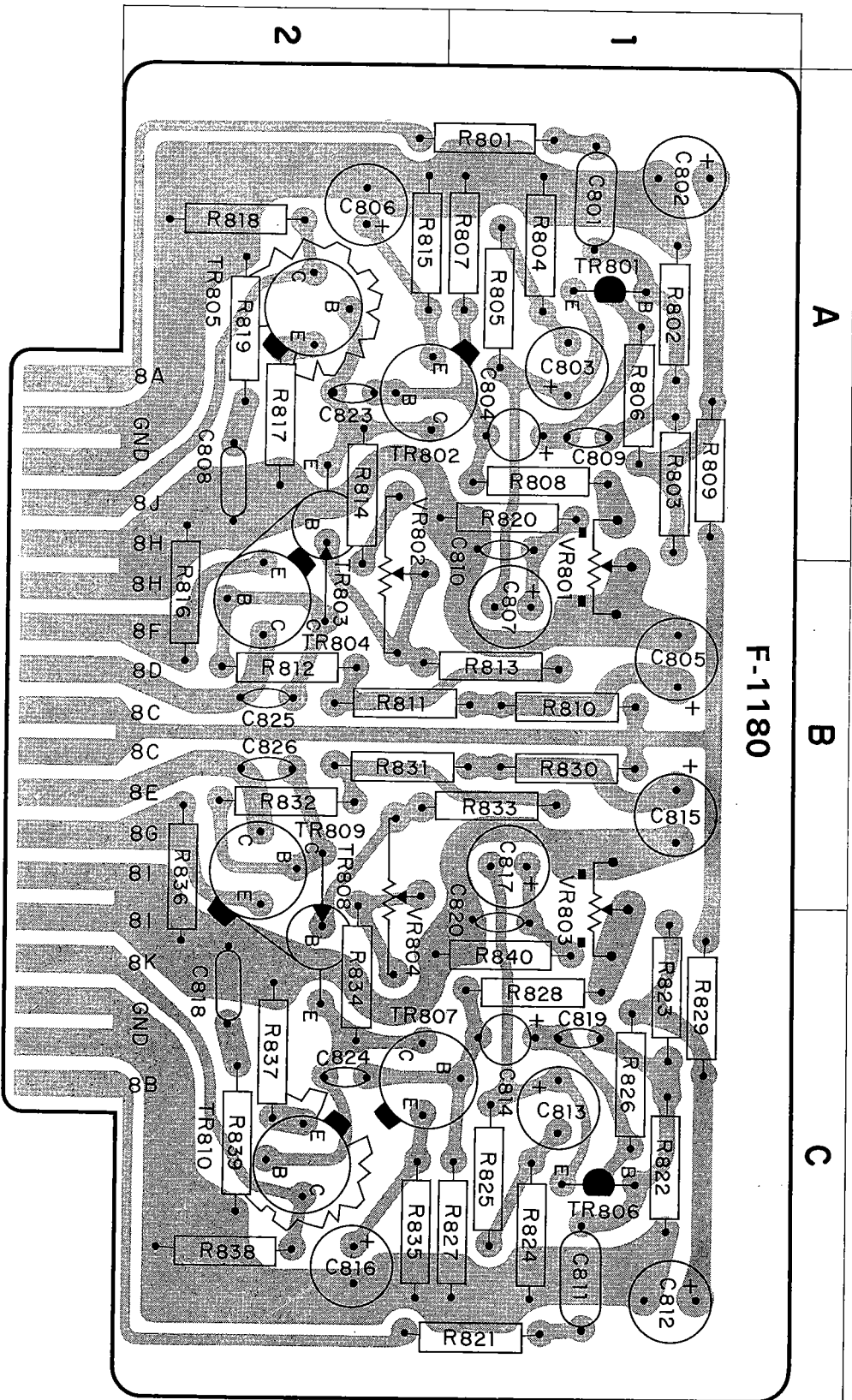

# PRINTED CIRCUIT BOARDS AND PARTS LIST

W: Parts No. X: Parts Name Y: Stock No. Z: Position of Parts

## POWER BLOCK <F-1373>

W	X	Y	Z
R001	100Ω ±10% ¼W CR.	0101101	2A
R002	22Ω	0111220	1B
R003	47Ω	0111470	1A
R004	18kΩ ±10% ¼W CR.	0101183	2B
R006	2.7kΩ ±10% ¼W CR.	0101272	1B
R007	100Ω ±10% ½W SR.	0111101	1A
R008	5.6kΩ ±10% ¼W CR.	0101562	2A
R009	22Ω ±10% ½W SR.	0111220	1A
R010	12kΩ	0101123	2A
R011	3.9kΩ	0101392	1, 2A
R012	220Ω	0111221	2B
R013	100Ω ±10% ½W SR.	0111101	2B
C004	100μF 75 V EC.	0519301	2A
C005	100μF 35 V EC.	0514101	2B
C006	100μF 25 V EC.	0513101	2A

W	X	Y	Z
C007	100μF 35 V EC.	0514101	2A
C008	47μF 16 V EC.	0512470	2A
C009	0.01μF	0659011	2B
C010	0.01μF +80% -20%	0659011	1B
C011	0.01μF 500V CC.	0659011	1B
C035	1000μF 10 V EC.	0511102	2B
TR001	2SC959 (L, M)	0305741, 2	2A
TR002	2SC1061 (B, C)	0305771, 2	1B
TR003	2SD223 (B, C)	0308232, 40	1A
TR004	2SC1061 (B, C)	0305771, 2	1A
D003	10DC-1	0310680	1B
D004	10D-1	0310340	2B
ZD001	ZBI-25	0310710	1, 2B
ZD002		0310710	1, 2A

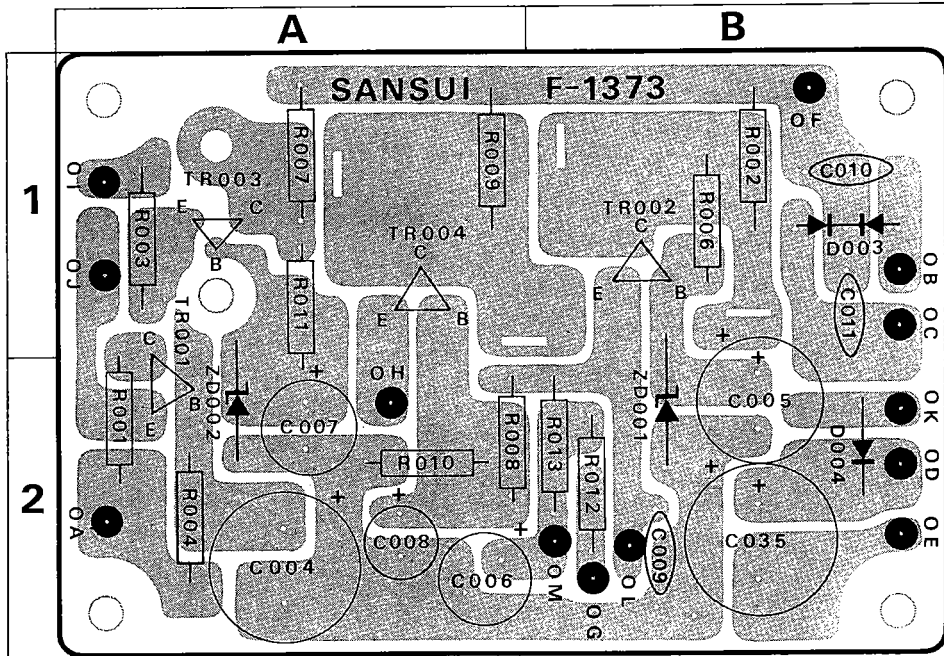

# OTHER PARTS AND THEIR POSITION ON CHASSIS

X: Parts Name Y: Stock No. Z: Position of Parts

W	X	Y
R015	330Ω	0111331
R016	330Ω	0111331
R017	330Ω	0111331
R018	330Ω	0111331
R019	330Ω	0111331
R020	330Ω	0111331
R021	330Ω	0111331
R022	330Ω	0111331
R035	390kΩ	0101394
R036	390kΩ	0101394
R037	100kΩ	0101104
R038	100kΩ	0101104
R039	390kΩ	0101394
R040	100kΩ	0101104
R041	390kΩ	0101394
R042	100kΩ	0101104
R043	390kΩ	0101394
R044	100kΩ	0101104
R045	390kΩ	0101394
R046	100kΩ	0101104
R049	18kΩ	0101183
R050	47Ω	0101470
R051	680Ω	0101681
R052	68Ω	0101680
R053	120Ω	0101121
R055	0.5Ω	0152058
R056	0.5Ω	0152058
R057	0.5Ω	0152058
R058	0.5Ω	0152058
R059	0.5Ω	0152058
R060	0.5Ω	0152058
R061	0.5Ω	0152058
R062	0.5Ω	0152058
R063	27kΩ	0101273
R064	27kΩ	0101273
R065	47kΩ	0101473
R066	47kΩ	0101473
R067	8.2kΩ	0101822
R068	8.2kΩ	0101822
R069	2.2kΩ	0101222
R070	220kΩ	0101224
R071	4.7Ω	0111479
R072	100Ω	0101101
R073	10Ω	0111100
R074	6.8Ω	0111689
VR001, 002	250kΩ (B) × 2 Main Volume	1090020
VR009~012		
VR003, 004	250kΩ (MN) Front Balance	1040090
VR005, 006		
VR007, 008	250kΩ (MN) × 2 Main Balance	1040110
VR013, 014		
VR017, 018	100kΩ (B) × 4 Front Tone Control	1060040
VR015, 016		
VR019, 020	100kΩ (B) × 4 Rear Tone Control	1060040
C001		
C002		
C003	1000μF } 50 V EC.	0559302
C012	0.01μF } 400V OC.	0590107
C013	0.01μF } 400V OC.	0590107
C014	0.033μF } 600V OC	0591337
C023	2200μF } 80 V EC.	0559820
C024	2200μF } 80 V EC.	0559820

W	X	Y
C025	2200μF } 80 V EC.	0559820
C026	2200μF } 80 V EC.	0559820
C027	0.0047μF } 600V OC.	0591476
C028	0.01μF } 500V CC.	0659011
C033	0.022μF } +80%	0656223
C034	0.022μF } -20%	0656223
C036	100μF } 25 V EC.	0503101
C037	100μF } 6.3 V EC.	0510101
C038	1000μF } 25 V EC.	0513102
C039	3.3μF } 25 V EC.	0513339
C040	3.3μF } 16 V BpEC.	0532339
C041	33μF } 16 V EC.	0512330
C042	47μF } 6.3 V EC.	0510470
VC001~003	AM 3 Gang Variable Capacitor	1200050
TR005~012	2SC793 (Y, BL)	0305451, 2
D001, 002	5B2	0310660
S1 (a~m)	Selector Switch	1105100
S12(a,b)	Front Speakers Switch	1102280
S13(a,d)	Rear Speakers Switch	1101310
S14(a~e)	Mode Switch	1103390
S15(a~f)	Function Switch	1102320
S16	FM Antenna Switch	1110040
S001	Power Switch	1130350
L001	75Ω : 300Ω FM balloon	4290021
L002	150μH Ferri Inductor	4900080
L003	AM Bar Antenna	4200460
PT001	Power Transformer	4000960
M001	200μA Signal Meter	4300470
M002	±100μA Tuning Meter	4300460
J001	Front Headphones Jack	2430060
J002	Rear Headphones Jack	2430060
J003	Tape Rec. 2 Jack	2430070
J004	Tape Mon. 2 Jack	2430070
DIN001	DIN Connector (2CH.)	2430040
DIN002	DIN Connector (4CH. Front)	2430040
DIN003	DIN Connector (4CH. Rear)	2430040
PU001	Voltage Selector	2410170 2410180 2410190
CO001~003	AC Outlet	2450040
F001	5A (100~127V) Power Fuse	0431280
	3A (220~250V) Power Fuse	0431260
F002~005	3A Quick Acting Fuse	0433250
PL001	7V 0.2A AUX (4CH) Indicator	0400141
PL002	7V 0.2A AUX (2CH) Indicator	0400141
PL003	7V 0.2A PHONO 1 Indicator	0400141
PL004	7V 0.2A PHONO 2 Indicator	0400153
PL010	6.3V 0.25A Signal Meter Lamp	0420020
PL011	6.3V 0.075A Dial Pointer Lamp	0400200
PL012	7V 0.2A 4Channel Indicator	0400153
PL013	6.3V 0.25A Tune Meter Lamp	0420020
PL014	6.3V 0.075A } 2, 4 Digital Indicator	0400200
PL015	6.3V 0.075A } Lamps	
PL017	7V 0.2A } 0400154	
PL018	6V 0.1A FM Stereo Indicator	0400161
PL019	7V 0.2A FM Indicator	0400154
PL020	7V 0.2A AM Indicator	0400154
	FM Front End	7510420

# OTHER PARTS AND THEIR POSITION ON CHASSIS

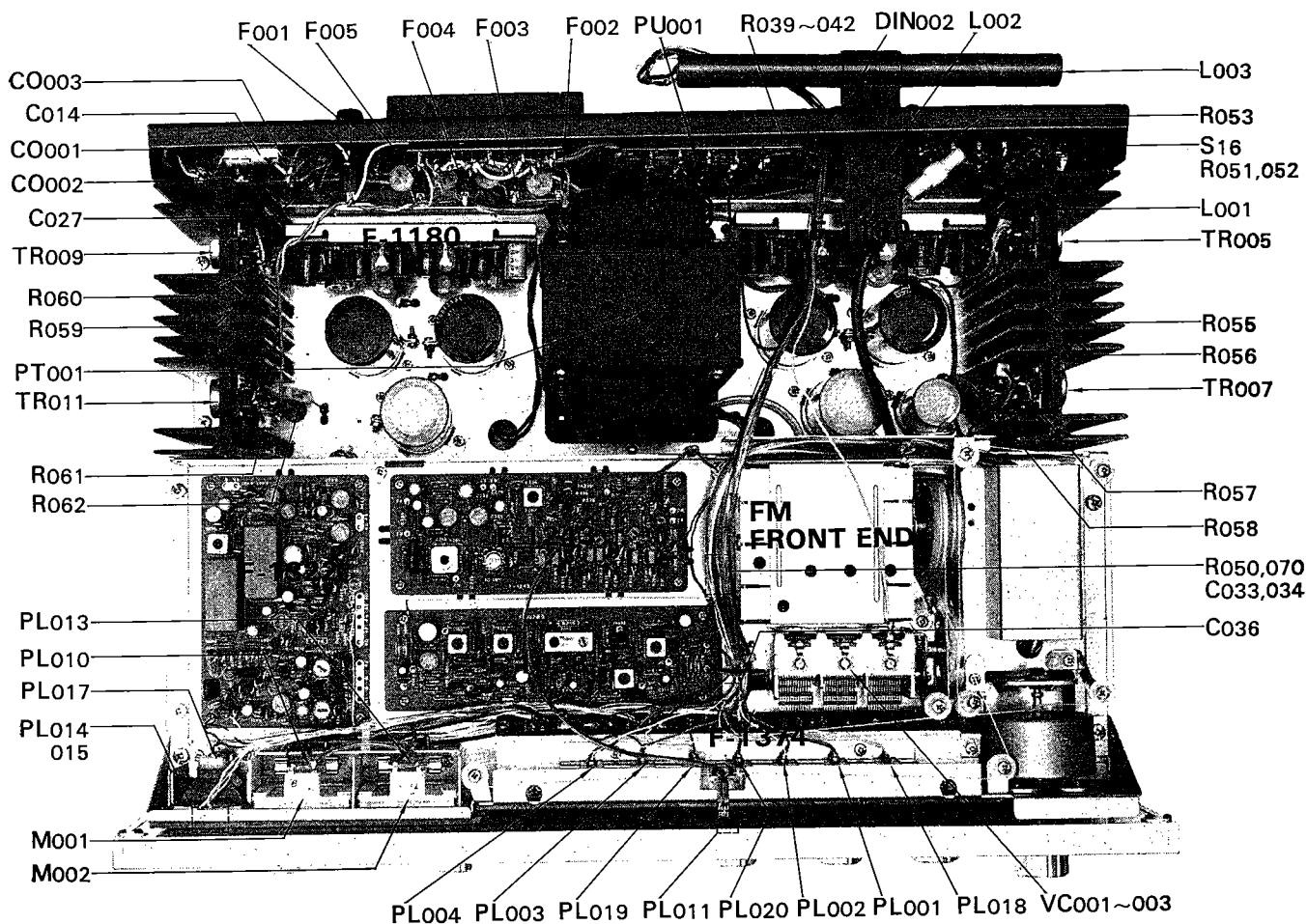

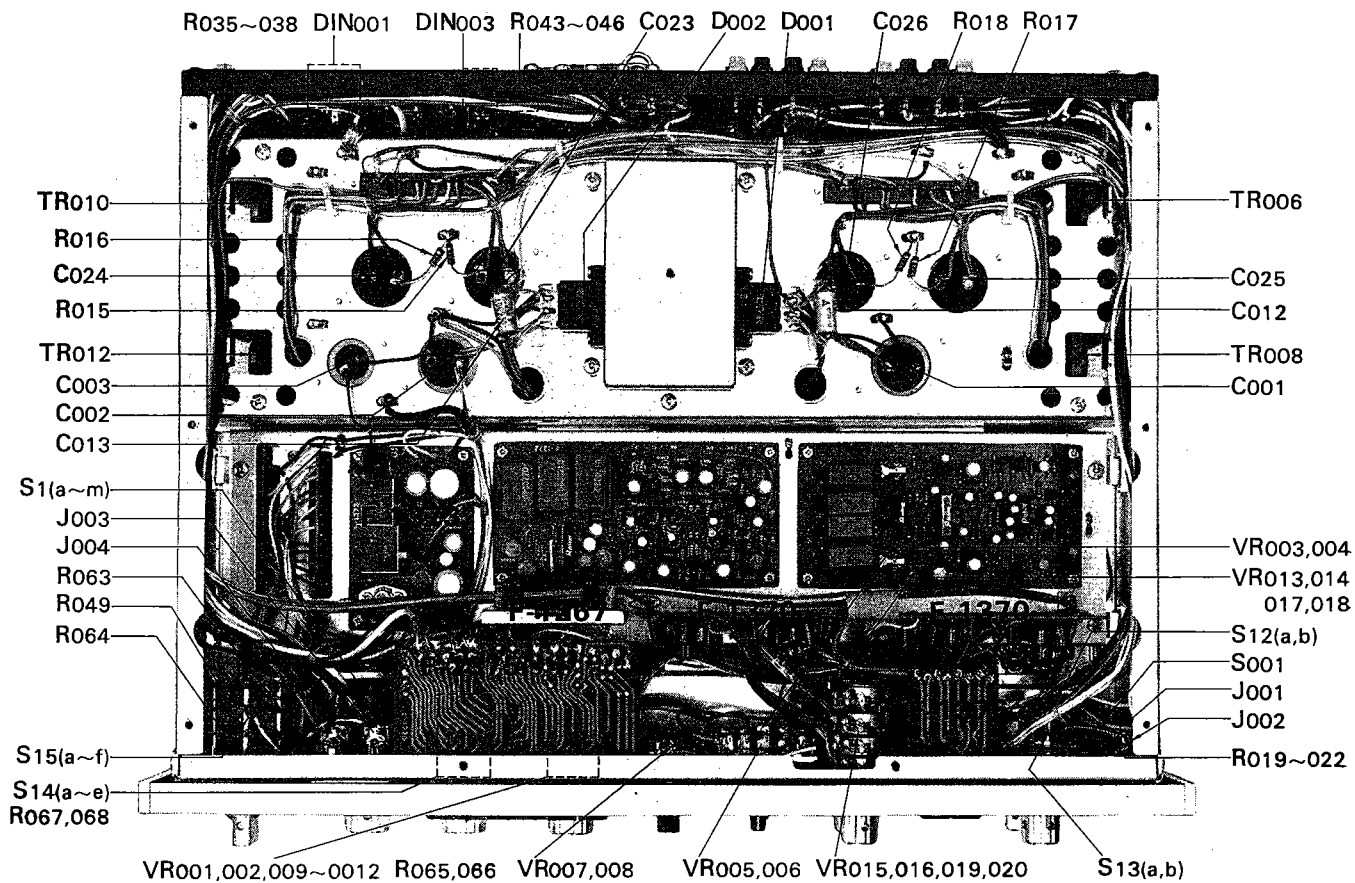



**SANSUI ELECTRIC CO., LTD.**

14-1, 2-chome, Izumi, Suginamiku, Tokyo 168, Japan.  
TELEPHONE: (03) 323-1111/TELEX: 232-2076

---

Stock No. 9216080

Printed in Japan (72030M8)