

SERVICE MANUAL

4-CHANNEL RECEIVER
SANSUI QRX-2000



Sansui

SANSUI ELECTRIC CO., LTD.

This service manual is designed for service engineers to repair, adjust, maintain and order the replacement parts of the QRX-2000 correctly. When ordering the parts, use the stock number and parts name specifically referring to the Parts Locations & Parts List. For general usage and maintenance of the unit, please refer to the Operating Instructions attached with the unit.

TABLE OF CONTENTS

<u>Section</u>	<u>Title</u>	<u>Page</u>
1.	SPECIFICATIONS	2
2.	BLOCK DIAGRAM AND VALUE OF EACH LEVEL	3
3.	THREADING OF DIAL CORD	4
4.	ALIGNMENTS AND ADJUSTMENTS	5
4-1.	Driver Circuit Board Adjustment	5
4-2.	FM IF Alignment	5, 6
4-3.	FM Dial Calibration and RF Alignment	6
4-4.	MPX Alignment	7
4-5.	AM IF, Dial Calibration, RF Alignment	7, 8
5.	TROUBLESHOOTING CHART	9
5-1.	Troubleshooting on Power Supply Section	9
5-2.	Troubleshooting on Audio Section	9
5-3.	QS SYNTHESIZER or QS REGULAR MATRIX of FUNCTION Switch inoperative (2-CH of FUNCTION switch inoperative)	9
5-4.	Troubleshooting on Tuner Section	9, 10
6.	PARTS LOCATIONS AND PARTS LISTS	11
6-1.	F-1493 Equalizer Circuit Board	11
6-2.	F-1496 Tone Control & Power Supply Circuit Board	12
6-3.	F-1498A Tuner Circuit Board	13, 14
6-4.	F-1492 Vario-Matrix Circuit Board	15, 16, 17
6-5.	F-1495 Driver Circuit Board	18
6-6.	Other Parts (Front Side)	19, 20
6-7.	Other Parts (Top Side)	21
6-8.	Other Parts (Bottom Side)	22
7.	PACKING LIST	23
8.	ACCESSORY PARTS LIST	23
9.	SCHEMATIC DIAGRAM OF TUNER SECTION	24
10.	SCHEMATIC DIAGRAM OF AUDIO SECTION	25

2. BLOCK DIAGRAM AND VALUE OF EACH LEVEL

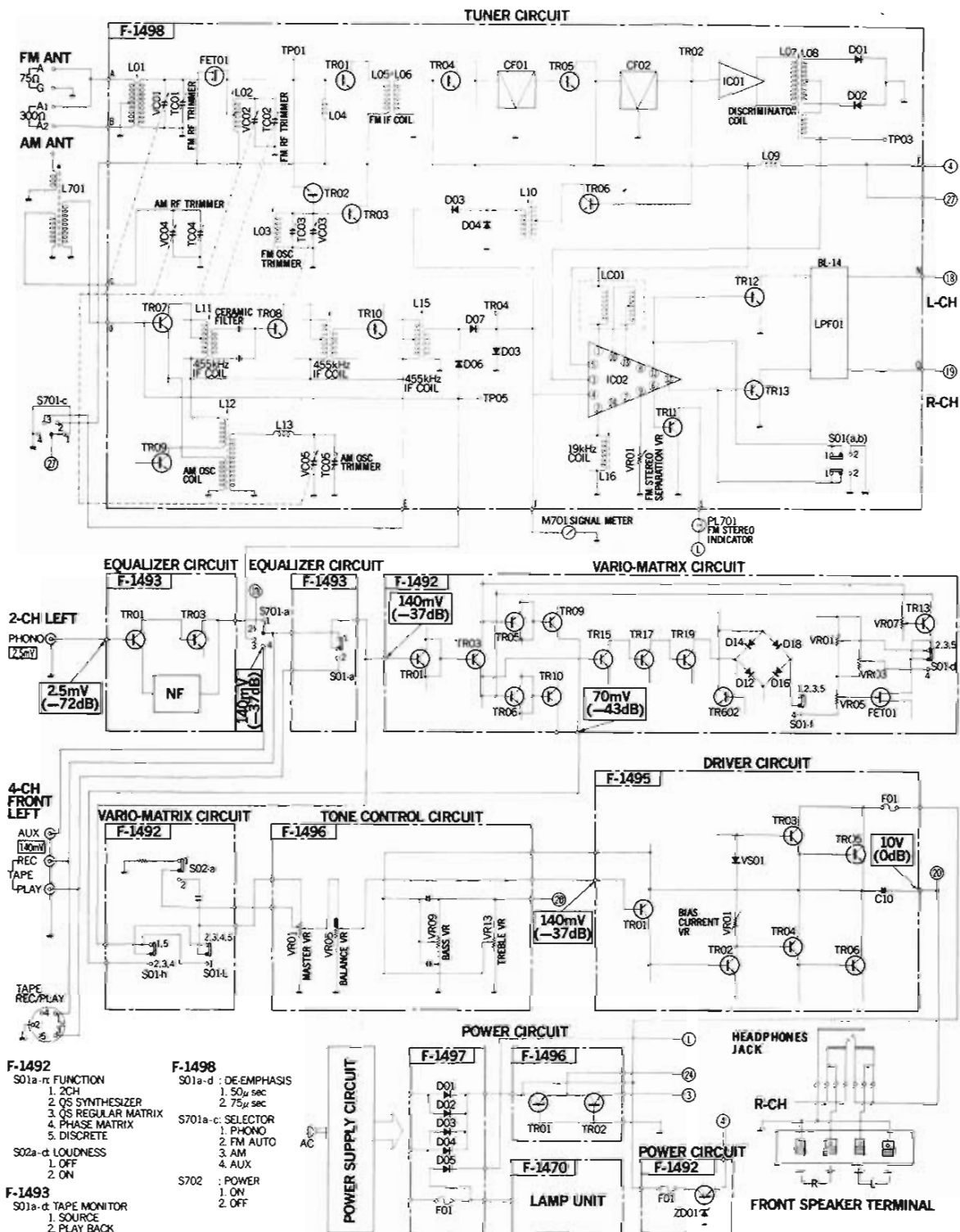

Conditions of Level Measuring

*Value of each level in block diagram was measured by the followings.

1. MASTER VOLUME control Maximum
2. BASS, TREBLE, BALANCE volume control Center
3. Input PHONO 2.5mV 1kHz Sine Wave AUX 140 mV 1kHz Sine Wave (output impedance of

600 Ω at an audio oscillator)

4. Output 10V (12W) 8 Ω
- Note:** Each voltage value is for reference and measured by a VTVM. In some recorders, the actual voltage value is in minor difference from the reference value.

3. THREADING OF DIAL CORD

If dial cord is cut or slips, replace cord by following procedures. As QRX-2000 is used 0.6mm ϕ cord, please replace it with same type certainly.

* Length of dial cord approx. 170cm (67inch)

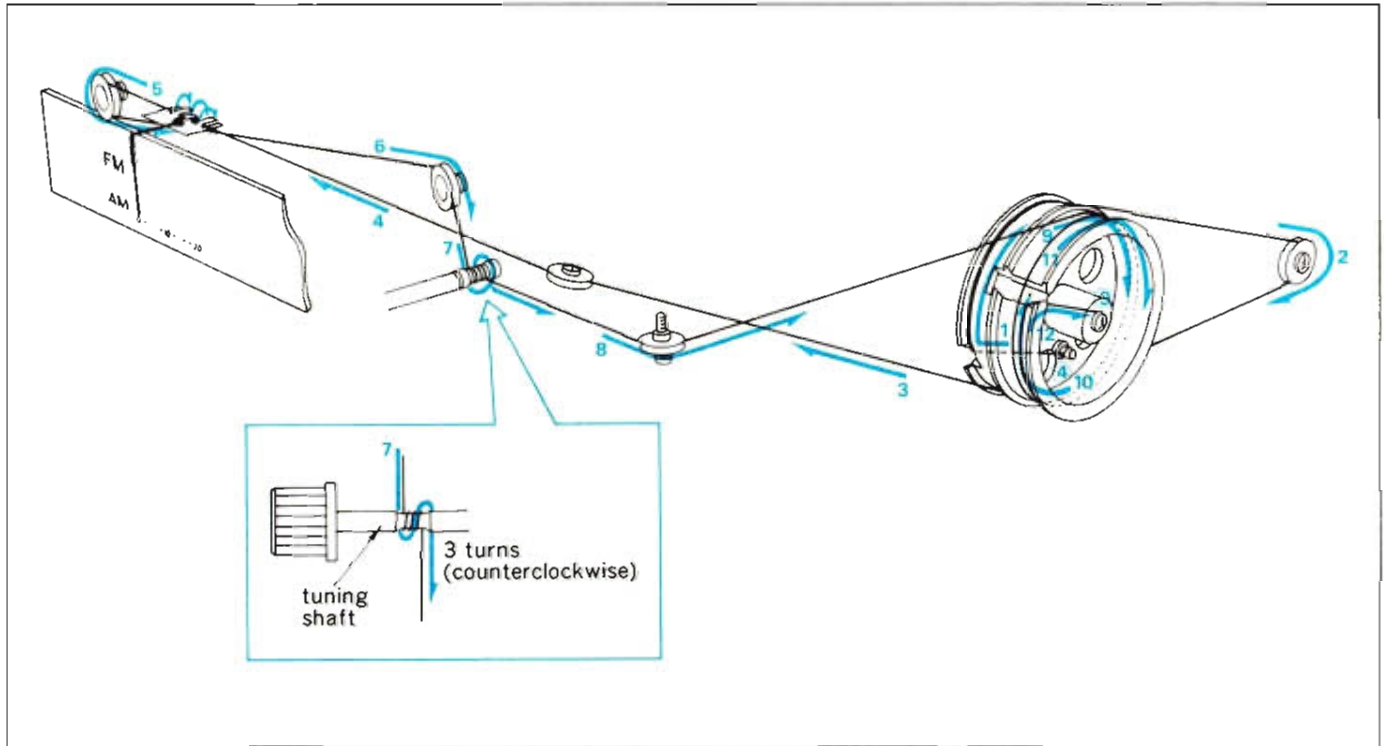

1. Threading of Dial Cord

Thread dial cord in numerical order from 1 to 12 as shown in Fig. 3-1.

- 1) Close the variable capacitor completely (Max. capacitance) and tie cord to number ④ screw of the dial pulley.
- 2) Thread cord in the direction of arrow from 1 to 6, then wind cord three turns around the tuning shaft counterclockwise.
- 3) Thread cord in the direction of arrow from 7 to 8, then wind it two turns on the dial pulley from 9 to 12.
- 4) After 12, tie cord to number ⑩ screw of the dial pulley.
* When you perform procedure 4) successfully, please refer to the followings.
 - ① To strengthen the dial cord tension, hold around the end of cord and pull it toward the Front Panel.
 - ② Then, turn tuning shaft counterclockwise, as the cord tension will be more constantly obtained.
 - ③ Tie the cord to number ⑩ screw of the dial pulley (same as procedure 4).
- 5) After procedures, lock the knots of cord with paint.

Stock No.	Description
6036050	Dial Cord (0.6mm ϕ)

4. ALIGNMENTS AND ADJUSTMENTS

Abbreviation

Equipment

AM FM Generator Oscilloscope Genescope
 AM Standard Signal Generator AM SSG
 FM Standard Signal Generator FM SSG
 FM Stereo Generator Stereo SG
 Oscilloscope Scope
 Audio Oscillator Audio Osci.
 Distortion Meter Dist. Meter

Others

Clockwise CW.
 Counterclockwise CCW.
 Antenna ANT.
 Modulation MOD.

4-1. Driver Circuit Board Adjustment (See Fig. 4-1)

- Note:** 1. Master Volume Minimum
 2. Make the SP terminals free (no load).
 3. Confirm the AC Power Supply voltage.
 4. After adjustment, run the unit for more than 5 minutes, then check and readjust necessary.
 5. Room temperature should be 18~28° (65~83°F) for bias current adjustment.

STEP	SUBJECT	EQUIPMENT	MEASURE OUTPUT	ADJUST	ADJUST FOR	CONDITION
1	Bias current	DC milliammeter	F-1495 F01 (Fig. 4-1)	F-1495 VR01	19 ± 1mA	o Step down meter's range accordingly

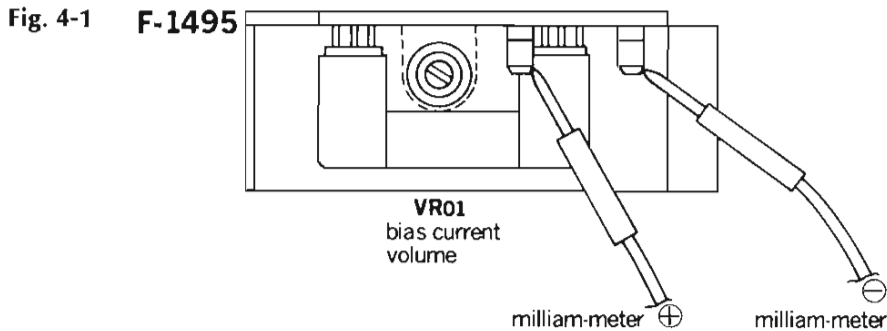

4-2. FM IF Alignment (See Figs. 4-6 and 4-7 on page 8)

- Note:** 1. Selector FM AUTO
 2. Master Volume Minimum
 3. Output level of genescope After attenuator
 4. Sweepwidth 1.5~2cm/150kHz
 5. Frequency band 9.5~11.5MHz
 6. Connection Connect the output of genescope to TP.01 through 100pF ceramic capacitor.

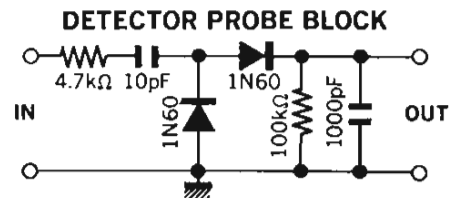
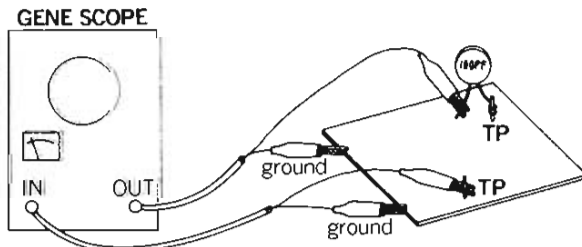

STEP	SUBJECT	FEED SIGNAL		MEASURE OUTPUT	ADJUST	ADJUST FOR	CONDITION
		FROM	TO				
1	IF coil	Output 55dB Genescope	TP. 01 (Fig. 4-7)	TP. 02 (Fig. 4-7) Use Detector Probe	L05, L06	Max. IF wave- form 1 as Fig. 4-6	o Turn core of L10 CCW.

STEP	SUBJECT	FEED SIGNAL		MEASURE OUTPUT	ADJUST	ADJUST FOR	CONDITION
		FROM	TO				
2	Meter coil	Same as above	Same as above	TP. 05 (Fig. 4-7) Direct from Genescope	L10	Max. IF wave- form 2 Set the center of waveform 2 with waveform 1 as Fig. 4-6	
3	Descrimina- tor coil	Same as above	Same as above	TP. 03 (Fig. 4-7) Direct from Genescope	L07 L08	Max. linearity of S curve Set the center of S curve waveform 1 & 2 as Fig. 4-6	

4-3. FM Dial Calibration, Mono Distortion and RF Alignment (See Fig. 4-7 on page 8)

- Note:**
1. Selector.....FM AUTO
 2. Master VolumeMinimum
 3. Confirm start point of dial pointer before alignment.
 4. In Step 3, 4 and 5, readjust items of steps 1, 2, if not correctly, and repeat 3, 4 and 5 again.

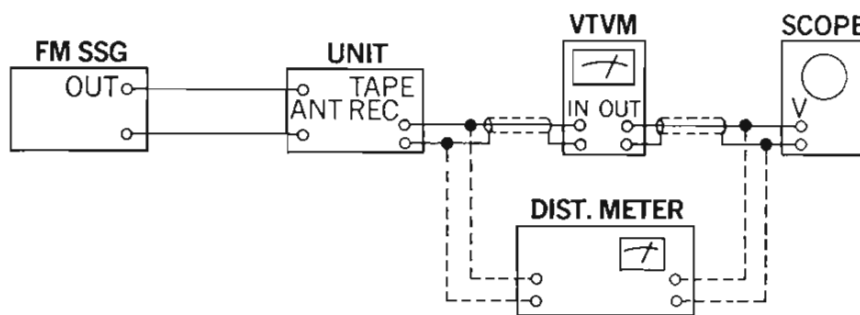

STEP	SUBJECT	FEED SIGNAL		MEASURE OUTPUT	ADJUST	ADJUST FOR	CONDITION
		FROM	TO				
1	88MHz Dial Calibration	88MHz ANT input 60dB 1kHz (100% MOD) FM SSG	ANT terminal 300Ω	REC OUT L or R-ch VTVM & Scope	L03	Max. output	◦Set Dial on 88MHz
2	108MHz Dial Calibration	108MHz ANT input 60dB 1kHz (100% MOD) FM SSG	Same as above	Same as above	Trimmer TC03	Same as above	◦Set Dial on 108MHz
3	Confirm 88MHz Dial Calibration	Same as Step 1	Same as above	Same as above		Confirm 88MHz Dial Calibration	◦If not, repeat from Step 1
4	Confirm 98MHz Dial Calibration	98MHz ANT input 60dB 1kHz (100% MOD) FM SSG	Same as above	Same as above		Confirm 98MHz Dial Calibration	
5	Confirm 108MHz Dial Calibration	Same as Step 2	Same as above	Same as above		Confirm 108MHz Dial Calibration	◦If not, repeat from Step 2
6	88MHz RF Adj.	88MHz ANT input 10dB 1kHz (100% MOD) FM SSG	Same as above	Same as above	L01, L02	Max. output	◦Tune FM SSG (Max. indication of Signal Meter)
7	108MHz RF Adj.	108MHz ANT input 10dB 1kHz (100% MOD) FM SSG	Same as above	Same as above	Trimmer TC01, TC02	Same as above	Same as above
8	Distortion	98MH ANT input 66dB 1kHz (100% MOD) FM SSG	Same as above	REC OUT L or R-ch Dist. meter & Scope	L07	Min. distortion	Same as above

4-4. MPX Alignment (See Fig. 4-7 on page 8)

- Note:** 1. SelectorFM AUTO
 2. Master Volume.....Minimum
 3. Before adjustment, turn VR05 to center.

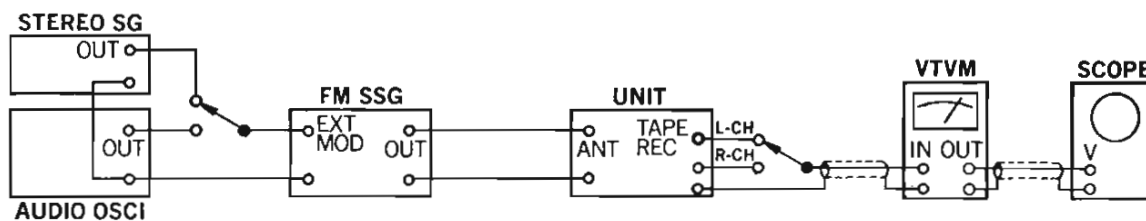

STEP	SUBJECT	FEED SIGNAL		MEASURE OUTPUT	ADJUST	ADJUST FOR	CONDITION
		FROM	TO				
1	19kHz coil	98MHz ANT input 60dB FM SSG Pilot 19kHz (10% MOD) L-ch 1kHz (45% MOD) R-ch (0% MOD) Stereo SG	ANT terminal 300Ω	REC OUT L-ch VTVM & Scope	L16	Max. output	o Tune FM SSG (Max. indication)
2	Separation	Same as above	Same as above	REC OUT R-ch VTVM & Scope	VR01	Min. output	
3	Cofirm Separation	98MHz ANT input 60dB FM SSG Pilot 19kHz (10% MOD) L-ch (0% MOD) R-ch 1kHz (45% MOD) Stereo SG	Same as above	REC OUT L-ch VTVM & Scope		Min. output	o If less the 35dB, adjust VR01

4-5. AM IF, Dial Calibration, RF Alignment (See Figs. 4-3, 4-4, 4-5 and 4-7 on page 8)

- Note:** 1. Selector.....AM
 2. Master VolumeMinimum
 3. Confirm start point of dial pointer before alignment.
 4. In case of using loop antenna, increase output of AM SSG for 26dB than bar antenna's direct input as it attenuates input sensitivity for 26dB (See Fig. 4-2).

Fig. 4-2

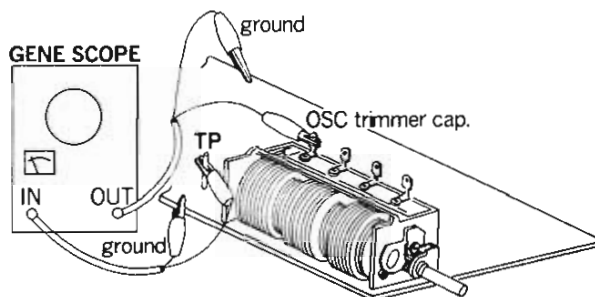
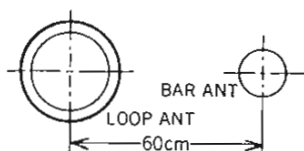

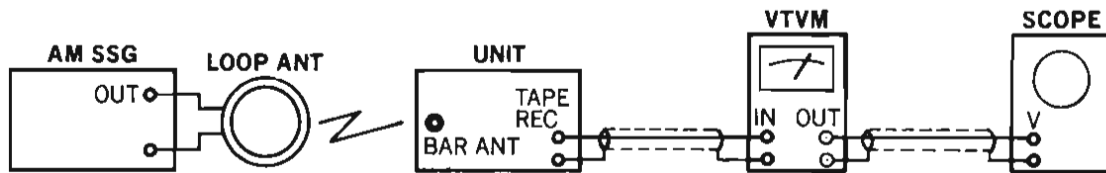



STEP	SUBJECT	FEED SIGNAL		MEASURE OUTPUT	ADJUST	ADJUST FOR	CONDITION
		FROM	TO				
1	IF coil	Output 90dB Genescope	OSC trimmer cap. (TC05) (Fig. 4-7)	TP. 04 (Fig. 4-7)	L13	Max. IF waveform as Fig. 4-3	○ Turn core L14 & L15 CCW.
2	IF coil	Output 70dB Genescope	Same as above	Same as above	L14	Max. IF waveform as Fig. 4-4	
3	IF coil	Output 60dB Genescope	Same as above	Same as above	L15	Max. IF waveform as Fig. 4-5	○ If not, readjust L13 & L14 slightly
4	535kHz Dial calibration	535kHz ANT input 86dB 400Hz (30% MOD) AM SSG Use loop ANT	Bar ANT	REC OUT L or R-ch VTVM & Scope	L12	Max. output	○ If broadcasting station is near, it might be used 
5	1400kHz Dial Calibration	1400kHz ANT input 86dB 400Hz (30% MOD) AM SSG Use loop ANT	Same as above	Same as above	Trimmer Cap. TC05	Same as above	Same as above 
6	Confirm 600kHz Dial Calibration	600kHz ANT input 86dB 400Hz (30% MOD) AM SSG Use loop ANT	Same as above	Same as above		Confirm 600kHz Dial Calibration	○ If not, repeat from Step 4
7	Confirm 1000kHz Dial Calibration	1000kHz ANT input 86dB 400Hz (30% MOD) AM SSG Use loop ANT	Same as above	Same as above		Confirm 1000kHz Dial Calibration	
8	Confirm 1400kHz Dial Calibration	Same as Step 5	Same as above	Same as above		Confirm 1400kHz Dial Calibration	○ If not, repeat from Step 5
9	600kHz RF Adj.	600kHz ANT input 50dB 400Hz (30% MOD) AM SSG Use loop ANT	Same as above	Same as above	Bar ANT L701	Max. output	
10	1400kHz RF Adj.	1400kHz ANT input 50dB 400Hz (30% MOD) AM SSG Use loop ANT	Same as above	Same as above	Trimmer Cap. TC04	Same as above	

Fig. 4-3

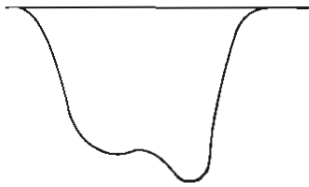

Fig. 4-4

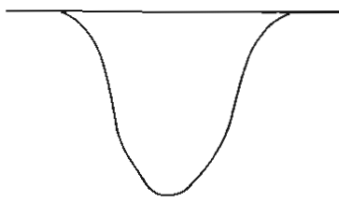

Fig. 4-5

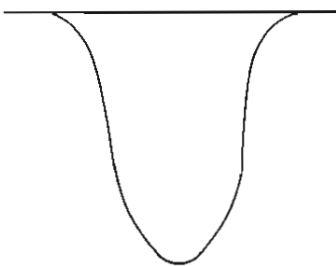

Fig. 4-6

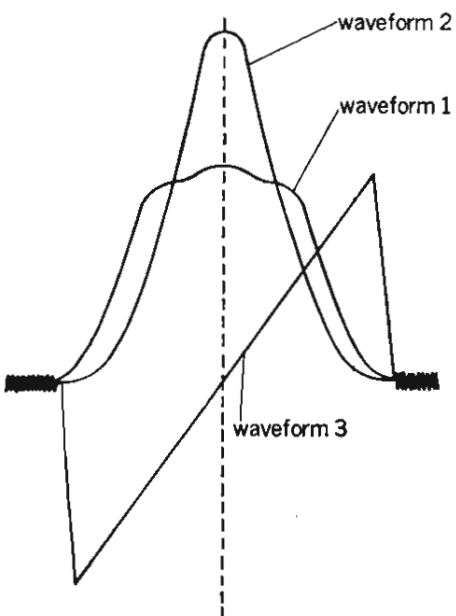
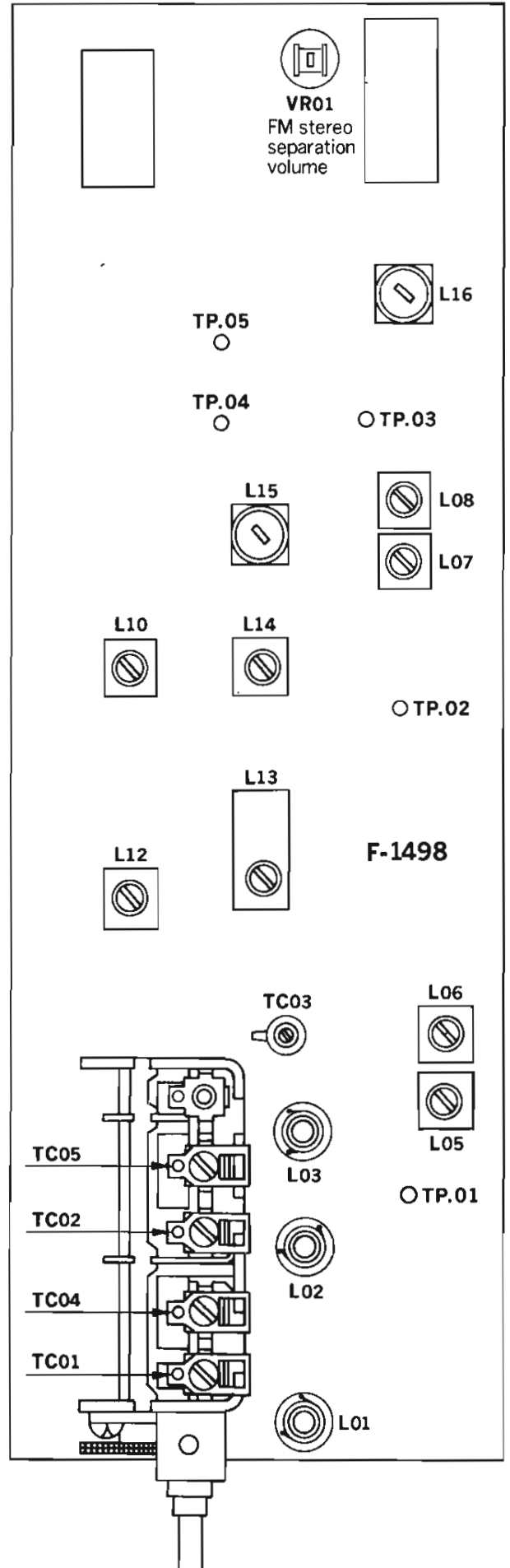

Fig. 4-7



5. TROUBLESHOOTING CHART

5-1. Troubleshooting on Power Supply Section

Symptom	Check Point	Cause & What to Do
1. No power supplied to each section		
1-1. Each lamp not lighted		1. Imperfect contact of power supply plug 2. Defective power switch S702 3. Power fuse F701 opens 4. F01 on F-1497 opens 5. Defective power transformer T701
1-2. Each lamp lighted		
	1) +44V not supplied to collector of TR601 on F-1496	6. Defective D01~D04 on F-1497
	2) +40V not supplied to emitter of TR601 on F-1496	7. Defective TR601 on F-1496
	3) +38V not supplied to emitter of TR602 on F-1496	8. Defective TR602 on F-1496

5-2. Troubleshooting on Audio Section

1. Quick acting fuse open

1-1. After replacement, fuse opens again		9. Defective TR05 or TR06 on F-1495 10. Defective TR03 or TR04 on F-1495 11. Defective VS01 on F-1495 12. Defective VR01 on F-1495
1-2. After replacement, fuse opens		
	1) DC bias current adjustable	13. Set the bias current to +10mA by VR01 on F-1495 (See page 5)
	2) DC bias current not adjustable	14. Defective VR01 on F-1495 15. Defective TR02 on F-1495

2. Quick acting fuse not opens

2-1. +44V supplied to collector of TR05 on F-1495		
	1) Center voltage +21V not supplied	16. Defective TR01 on F-1495
2-2. +44V not supplied to collector of TR05 on F-1495		17. F01 on F-1495 opens 18. Defective power supply section (F-1496)

3. AUX input inoperative (on 2-CH of FUNCTION switch)

3-1. Both channels inoperative		19. Defective power supply section (F-1496)
3-2. One channel inoperative		20. Defective TR01 on F-1495
		21. Defective VOLUME VR01 (VR02) on F-1496
		22. Defective BALANCE volume VR05 (VR06) on F-1496
		23. Defective BASS volume VR09 (VR10) on F-1496
		24. Defective TREBLE volume VR13 (VR14) on F-1496
		25. Imperfect contact of FUNCTION switch S01 on F-1492
		26. Imperfect contact of TAPE MONITOR switch S01 on F-1493
		27. Imperfect contact of SELECTOR switch S701
		28. Imperfect contact of LOUDNESS switch S02 on F-1492

Symptom**Check Point****Cause & What to Do****4. PHONO inoperative**

- 4-1. Both channels inoperative ————— 29. Defective power supply section (F-1496)
- 4-2. One channel inoperative
 - 1) Reverse the output cords of L and R-ch from turntable
 - 1-1) Inoperative channel reverses ————— 30. Imperfect contact of the output cord
 ————— 31. Defective turntable
 - 1-2) Inoperative channel not reverses ————— 32. Defective TR01, TR03 (TR02, TR04) on F-1493
 ————— 33. Imperfect contact of SELECTOR switch S701a (S701b)

5-3. QS SYNTHESIZER or QS REGULAR MATRIX of FUNCTION Switch inoperative (2-CH of FUNCTION switch inoperative)**1. Both Front L, R and Rear L, R inoperative**

- 1-1. +25V not supplied to collector of TR603 on F-1492 ————— 34. F01 on F-1492 opens
 ————— 35. Defective Power Supply Section (F-1496)
- 1-2. +25V not supplied to emitter of TR603 on F-1492 ————— 36. Defective TR603 on F-1492
 ————— 37. Defective ZD01 on F-1492

2. One Front L (R) or Rear L (R) inoperative

- 38. Defective TR01 or TR03 (TR02 or TR04) on F-1492
- 39. Defective TR15, TR17 or TR19 (TR16, TR18 or TR20) on F-1492
- 40. Defective TR601 on F-1492
- 41. Defective D11, D13, D15 or D17 (D12, D14, D16 or D18) on F-1492
- 42. Defective FET01 (FET02) on F-1492
- 43. Defective TR13 (TR14) on F-1492
- 44. Defective TR05 or TR09 (TR06 or TR10) on F-1492
- 45. Defective TR07 or TR11 (TR08 or TR12) on F-1492
- 46. Imperfect contact of FUNCTION switch S01

5-4. Troubleshooting on Tuner Section**1. Both FM and AM inoperative (PHONO operative)**

- 1-1. Both channels inoperative
 - 1) +15V not supplied to terminal **C**, **E** and +25V not supplied to terminal **F** on F-1498 ————— 1. Defective F-1492 or F-1497
 - 2) +15V not supplied to terminal **C**, **E** on F-1498 ————— 2. Imperfect contact of SELECTOR switch S701c
- 1-2. One channel inoperative
 - 1) AM section inoperative ————— 3. Imperfect contact of SELECTOR switch S701a (S701b)
 - 2) FM section inoperative ————— 4. Defective TR12 (TR13) on F-1498
 ————— 5. Defective Low Pass Filter, LPF01 on F-1498
 ————— 6. Defective LC01 on F-1498
 ————— 7. Imperfect connect of SELECTOR switch S701a (S701b)

Symptom	Check Point	Cause & What to Do
2. FM Section		
2-1. FM inoperative only	1) Tune FM signal or FM broadcasting station	
	1-1) Signal meter inoperative	8. Defective CF01 or CF02 on F-1498 9. Defective FET01, TR01~TR05 on F-1498 10. Defective L01~L06 on F-1498
	1-2) Signal meter operative (Interstation noise too low compared with proper unit)	11. Defective IC01 on F-1498 12. Defective L07 or L08 on F-1498 13. Defective D01 or D02 on F-1498
2-2. Signal meter inoperative (FM broadcasting sound can be heard)		14. Defective TR06 on F-1498 15. Defective L10 on F-1498 16. Defective D03 or D04 on F-1498 17. Defective signal meter
2-3. No channel separation on FM stereo broadcasting * Confirm that SELECTOR switch is set to FM AUTO	1) Indicator lamp not lighted	18. Defective IC02 on F-1498 19. Defective L16 on F-1498 20. Defective TR11 on F-1498 21. Defective VR01 for indicator lamp on F-1498 22. Defective the indicator lamp, PL701 23. F01 on F-1497 opens
	2) Indicator lamp lighted	24. Defective TR11 on F-1498 25. VR01 out of adjustment on F-1498
3. AM Section		
3-1. AM inoperative	1) Interstation noise changes by touching the terminal \square on F-1498	
	1-1) No change	26. Defective TR07, TR08 or TR10 on F-1498 27. Defective L11, L14 or L15 on F-1498 28. Defective D06 on F-1498
	1-2) Increase	29. Defective bar antenna, L701 30. Defective TR09 on F-1498 31. Defective L12 on F-1498 32. Variable capacitor shorted
3-2. Distortion		33. Defective D05 or D06 on F-1498 34. IF out of adjustment on F-1498
3-3. Signal meter inoperative (AM broadcasting sound can be heard)		35. Defective D07 on F-1498 36. Defective signal meter

6. PARTS LOCATIONS AND PARTS LISTS

6-1. F-1493 Equalizer Circuit Board (Stock No. 7550550 Complete Circuit Board F-1493)

Conductor Side

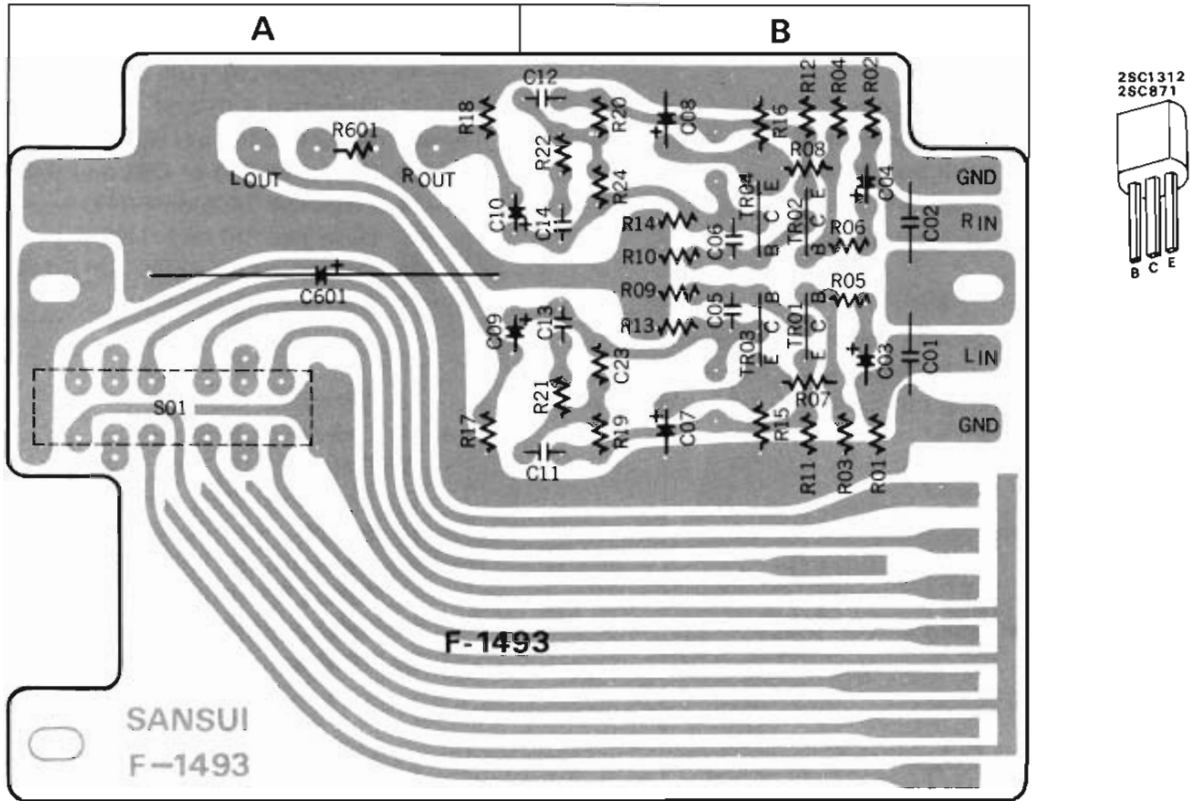

Parts List

Parts No.	Stock No.	Description	Position
TR01, 02	0306090 or 0305475	2SC1312 (F) or 2SC871 (F)	B
TR03, 04	0306090 or 0305475	2SC1312 (F) or 2SC871 (F)	
		Transistor	
C01, 02	0657473	0.047 μ F 50V C.C.	A, B
C03, 04	0573339	3.3 μ F 25V T.C.	B
C05, 06	0660680	68pF 50V C.C.	B
C07, 08	0511470	47 μ F 10V E.C.	B
C09, 10	0519103	0.47 μ F 50V E.C.	A
C11, 12	0601476	0.0047 μ F } 50V M.C.	A, B
C13, 14	0601126		0.0012 μ F } B
C601	0504221	220 μ F 35V E.C.	A
R01, 02	0106563	56k Ω	B
R03, 04	0106224	220k Ω	B
R05, 06	0106332	3.3k Ω	B
R07, 08	0106824	820k Ω	B
R09, 10	0106104	100k Ω	B
R11, 12	0106122	1.2k Ω	B
R13, 14	0106822	8.2k Ω	B
R15, 16	0106272	2.7k Ω	B
		$\frac{1}{4}$ W C.R. (E.L.R.)	

Parts No.	Stock No.	Description	Position
R17, 18	0106104	100k Ω	A
R19, 20	0106824	820k Ω	B
R21, 22	0106272	2.7k Ω	B
R23, 24	0106563	56k Ω	B
R601	0106561	560 Ω	A
S01 (a-d)	1110250	Push Switch	A

Abbreviations

C.R. : Carbon Resistor	BP.E.C.: Bi-Polar Electrolytic Capacitor
S.R. : Solid Resistor	C.C. : Ceramic Capacitor
Ce.R. : Cement Resistor	Mi.C. : Mica Capacitor
M.R. : Metallized Film Resistor	O.C. : Oil Capacitor
M.C. : Mylar Capacitor	P.C. : Polystyrene Capacitor
E.C. : Electrolytic Capacitor	T.C. : Tantalum Capacitor

6-2. F-1496 Tone Control & Power Supply Circuit Board

Conductor Side

(Stock No. 7570830 Complete Circuit Board F-1496)

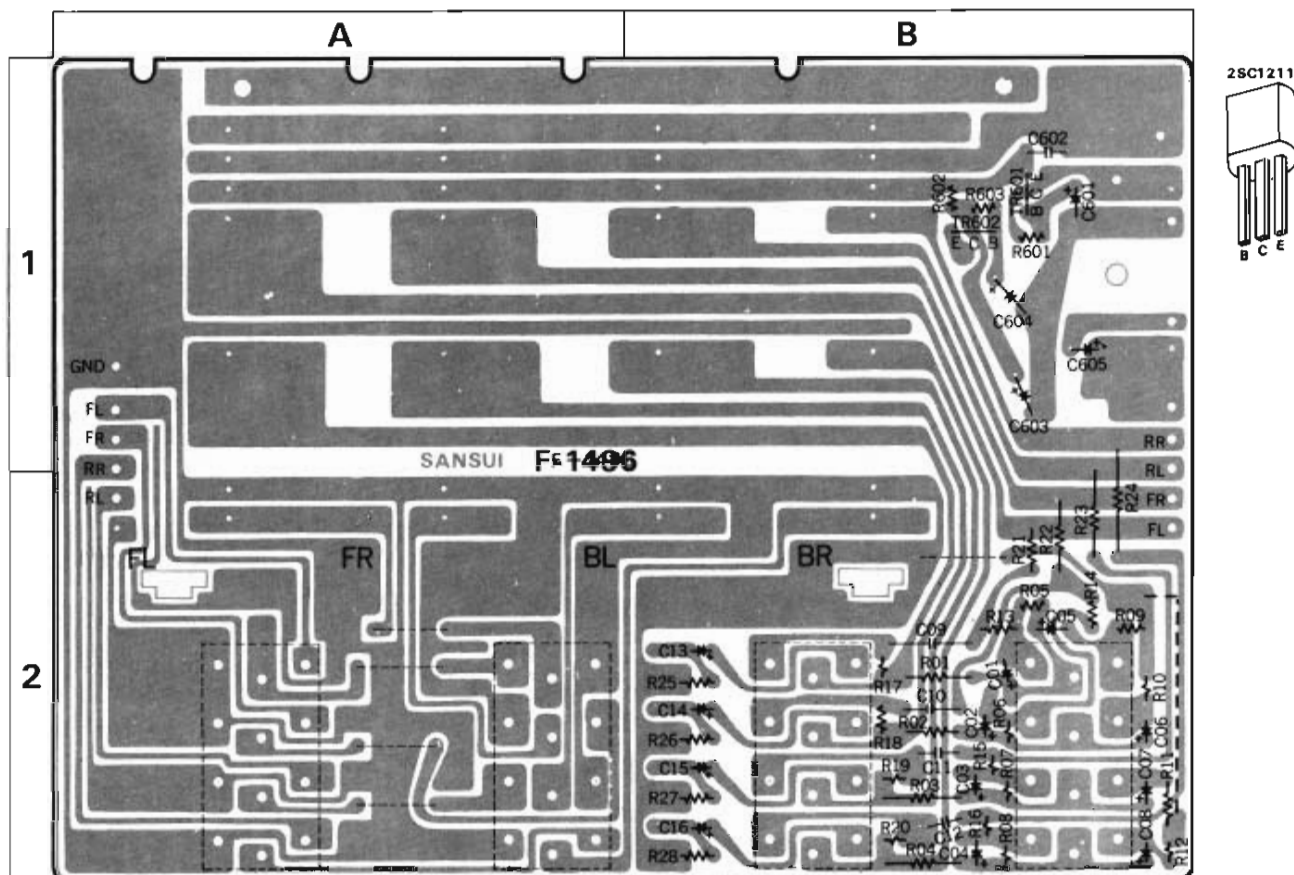

Parts List

Parts No.	Stock No.	Description	Position
TR601	0305930, 1	2SC1211 (C, D) } Transistor	1 B
TR602	0305930, 1		1 B
C01,02	0573158	0.15 μ F } 25V T.C.	2 B
C03,04	0573158		2 B
C05,06	0519104	1.5 μ F } 50V E.C.	2 B
C07,08	0519104		2 B
C09,10	0601337	0.033 μ F } 50V M.C.	2 B
C11,12	0601337		2 B
C13,14	0573338	0.33 μ F } 25V T.C.	2 B
C15,16	0573338		2 B
C601	0515101	100 μ F } 50V E.C.	1 B
C602	0657473	0.047 μ F } 50V C.C.	1 B
C603	0515331	330 μ F } 50V E.C.	1 B
C604	0515331	330 μ F } 50V E.C.	1 B
R01,02	0107561	560 Ω } $\frac{1}{4}$ W C.R.	2 B
R03,04	0107561		2 B
R05,06	0106123	12k Ω } $\frac{1}{4}$ W C.R.	2 B
R07,08	0106123		2 B
R09,10	0106151	150 Ω } $\frac{1}{4}$ W C.R.	2 B
R11,12	0106151		(E.L.R.) 2 B
R13,14	0106561	560 Ω } $\frac{1}{4}$ W C.R.	2 B
R15,16	0106561	560 Ω } $\frac{1}{4}$ W C.R.	2 B

Parts No.	Stock No.	Description	Position
R17,18	0106153	15k Ω } $\frac{1}{4}$ W C.R.	2 B
R19,20	0106153	15k Ω } (E.L.R.)	2 B
R21	0106152	1.5k Ω } $\frac{1}{4}$ W C.R.	2 B
R22	0107152	1.5k Ω } $\frac{1}{4}$ W C.R.	2 B
R23,24	0107152	1.5k Ω } $\frac{1}{4}$ W C.R.	2B, 1, 2B
R25,26	0106560	56 Ω } $\frac{1}{4}$ W C.R.	2 B
R27,28	0106560	56 Ω } $\frac{1}{4}$ W C.R.	2 B
R601	0106682	6.8k Ω } $\frac{1}{4}$ W C.R.	1 B
R602	0106681	680 Ω } (E.L.R.)	1 B
R603	0106123	12k Ω } $\frac{1}{4}$ W C.R.	1 B
VR01-04	1060290, 1	250k Ω (B) \times 4 VOLUME	
VR05-08	1060300, 1	250k Ω (MN) \times 4 BALANCE	Volume
VR09-12	1060310, 1	5k Ω (C) \times 4 BASS Volume	
VR13-16	1060310, 1	5k Ω (C) \times 4 TREBLE Volume	
	2410570	5P Connector	

6-3. F-1498A Tuner Circuit Board (Stock No. 7520750 Complete Circuit Board F-1498A)

Parts List

Parts No.	Stock No.	Description	Position	Parts No.	Stock No.	Description	Position	
TR01	0305801, 2	2SC1047 (B, C)	Transistor	C06	0669209	8.2pF	1 A	
TR02	0305791, 2	2SC930 (D, E)		1 A	C07	0669353	18pF	2 A
TR03	0305790	2SC930 (C)		1 A	C08	0669347	12pF	50V C.C. 1 A
TR04	0306112, 3	2SC738 (C, D)		1 B	C09	0660221	220pF	
TR05	0306112, 3	2SC738 (C, D)		1 B	C10	0669353	18pF	1 A
TR06	0305942, 3	2SC710 (C, D)		2 B	C11	0656223	0.022μF	25V C.C. 1 A
TR07	0305992	2SC403C (4)		1, 2 B	C12	0656223	0.022μF	
TR08	0305992	2SC403C (4)		1, 2 B	C13	0669203	2.7pF	1 A
TR09	0305991	2SC403C (3)		2 B	C14	0669370	10pF	50V C.C. 1 A
TR10	0305991	2SC403C (3)		1, 2 C	C15	0669353	18pF	
TR11	0300291, 2	2SA678A (6, 7)		2 D	C16	0669370	10pF	1 A, B
TR12	0305475	2SC871 (R) (F)	2 D	C17	0656223	0.022μF	1 A	
	or 0306090	or 2SC1312 (R) (F)		C18	0656223	0.022μF	25V C.C. 1 A	
IC01	0360060	TA7061AP	IC	C19	0656223	0.022μF		1 A
IC02	0360080	HA1120		1 D	C20	0669320	10pF	50V C.C. 1 B
FET01	0370080, 1	3SK39 (Q, R) FET	1 A	C21	0656223	0.022μF	1 B	
D01	0311060	1N60P	Diode	C22	0656223	0.022μF	1 B	
D02	0311060	1N60P		1 C	C23	0656223	0.022μF	25V C.C. 1 B
D03	0310400	1N34A		2 C	C24	0656223	0.022μF	
D04	0310400	1N34A		2 C	C25	0656223	0.022μF	16V E.C. 1 D
D05	0310400	1N34A		2 B	C26	0656223	0.022μF	
D06	0310400	1N34A		1, 2 C	C27	0512101	100μF	2 B
D07	0310400	1N34A		1, 2 C	C28	0656223	0.022μF	
D08	0340090	DS430		1 C	C29	0656223	0.022μF	1 C
ZD01	0315090	EQB01-13 Zener Diode	2 C	C30	0656223	0.022μF	1 C	
CF01	0910150	SFE-10.7MA-M	Ceramic Filter	C31	0656223	0.022μF	25V C.C. 1 C	
CF02	0910150	SFE-10.7MA-M		1 B	C32	0656223		0.022μF
L01	4200570	FM ANT Coil	1 A	C33	0656223	0.022μF	25V C.C. 1 C	
L02	4210200	FM RF Coil	1 A	C34	0656223	0.022μF		2 B
L03	4290110	Choke Coil	1 A	C35	0656223	0.022μF	2 B	
L04	4220400	FM OSC Coil	1 A	C36	0656223	0.022μF	2 C	
L05	4235890	10.7MHz (WHITE)	FM IF Coil	C37	0656223	0.022μF	2 C	
L06	4235900	10.7MHz (BLACK)		1 A, B	C38	0512100	10μF	16V E.C. 1 C
L07	4235750	10.7MHz (PINK)	FM Discriminator Coil	C39	0660221	220pF	50V C.C. 1 C	
L08	4235760	10.7MHz (BLUE)		1 C	C40	0660221		220pF
L09	4290011	3.5μF Peaking Coil	1, 2 C	C41	0660331	330pF	1 C	
L10	4235770	10.7MHz (GREEN) FM Meter Coil	2 B, C	C42	0656223	0.022μF	25V C.C. 2 B	
L11	0910180	YEL-455E2 (CFW-555B) Ceramic Filter	1, 2 C	C43	0615339	3.3μF	50V E.C. 2 B	
L12	4220380	AM OSC Coil	2 B	C44	0656473	0.047μF	25V C.C. 2 B	
L13	4290011	3.5μH Peaking Coil	2 A	C45	0601107	0.01μF	50V M.C. 2 B	
L14	4230500	455kHz (BLUE)	AM IF Coil	C46	0656473	0.047μF	25V C.C. 2 B	
L15	4230610	455kHz (BLACK)		1, 2 C	C47	0656473	0.047μF	25V C.C. 2 B
L16	4240720	19kHz Coil	1 D	C48	0660100	10pF	50V C.C. 2 B	
LC01	4240710	MPX Coil	1 D	C49	0601107	0.01μF	50V M.C. 2 B	
LPF01	0910220	Low Pass Filter	2 D	C50	0512100	10μF	16V E.C. 2 B	
TC03	1230090	ECV-1ZW06P Ceramic Trimmer	1 A, B	C51	0656473	0.047μF	25V C.C. 2 B	
VC01~05	1220150	Variable Capacitor		C52	0620361	360pF	50V P.C. 2 B	
C01	0669347	12pF	50V C.C.	2 A	C53	0660150	15pF	50V C.C. 2 B
C02	0656102	0.001μF		1 A	C54	0656473	0.047μF	1 B
C03	0656223	0.022μF	25V C.C.	1 A	C55	0656473	0.047μF	2 B
C04	0656223	0.022μF		1 A	C56	0656473	0.047μF	25V C.C. 2 B
C05	0656223	0.022μF		1 A	C57	0656473	0.047μF	
					C58	0656473	0.047μF	2 C
				C59	0512479	4.7μF	16V E.C. 2 B	
				C60	0656473	0.047μF	25V C.C. 2 C	
				C61	0512479	4.7μF	16V E.C. 2 C	
				C62	0656473	0.047μF	25V C.C. 2 C	
				C63	0656473	0.047μF	25V C.C. 2 C	
				C64	0601477	0.047μF	50V M.C. 2 C	
				C65	0656472	0.0047μF	25V C.C. 2 C	
				C66	0656223	0.022μF	25V C.C. 2 C	

Conductor Side

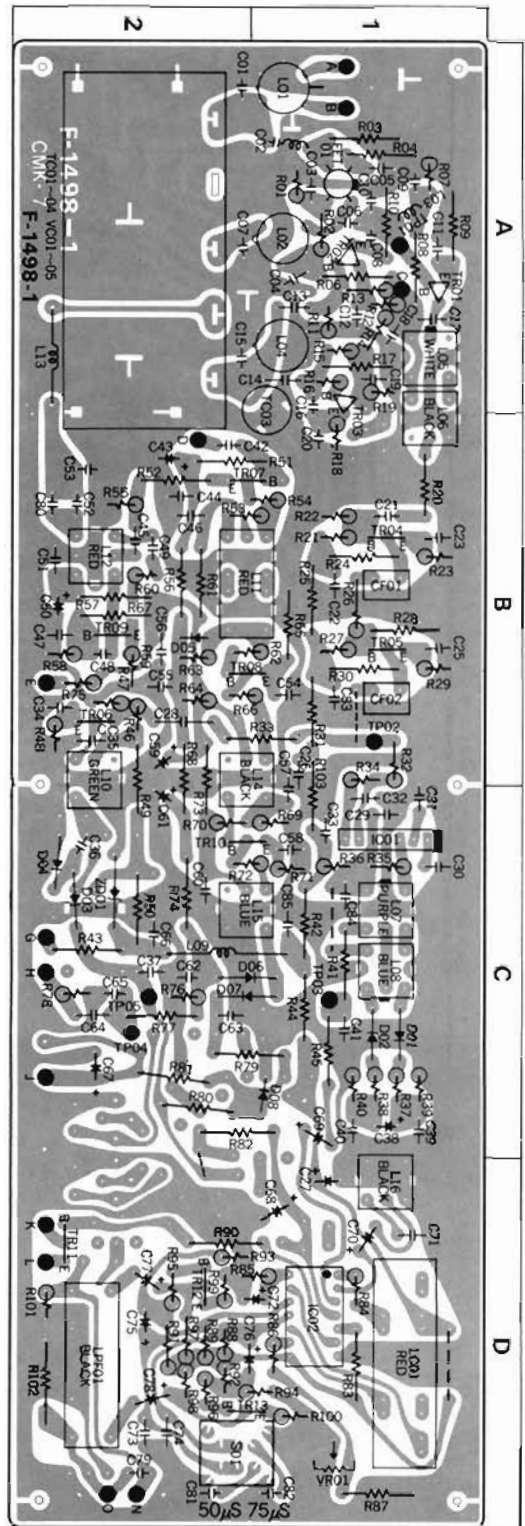

Conductor Side

Part No.	Stock No.	Description	Position
C47	0510101	100µF	2C
C46	0519101	1µF	1D
C45	0515109	50V E.C.	1C
C44	0515339	3.3µF	1D
C43	0512100	680µF	1D
C42	0512100	10µF	1D
C41	0601187	0.01µF	2D
C40	0601187	0.01µF	2D
C39	0515109	1µF	2D
C38	0515109	1µF	2D
C37	0515109	1µF	2D
C36	0515109	1µF	2D
C35	0601136	0.0017µF	2D
C34	0601136	15µF	2D
C33	0601136	50V M.C.	2D
C32	0601136	50V M.C.	2D
C31	0601136	50V M.C.	2D
C30	0601136	50V M.C.	2D
C29	0601136	50V M.C.	2D
C28	0601136	50V M.C.	2D
C27	0601136	50V M.C.	2D
C26	0601136	50V M.C.	2D
C25	0601136	50V M.C.	2D
C24	0601136	50V M.C.	2D
C23	0601136	50V M.C.	2D
C22	0601136	50V M.C.	2D
C21	0601136	50V M.C.	2D
C20	0601136	50V M.C.	2D
C19	0601136	50V M.C.	2D
C18	0601136	50V M.C.	2D
C17	0601136	50V M.C.	2D
C16	0601136	50V M.C.	2D
C15	0601136	50V M.C.	2D
C14	0601136	50V M.C.	2D
C13	0601136	50V M.C.	2D
C12	0601136	50V M.C.	2D
C11	0601136	50V M.C.	2D
C10	0601136	50V M.C.	2D
C9	0601136	50V M.C.	2D
C8	0601136	50V M.C.	2D
C7	0601136	50V M.C.	2D
C6	0601136	50V M.C.	2D
C5	0601136	50V M.C.	2D
C4	0601136	50V M.C.	2D
C3	0601136	50V M.C.	2D
C2	0601136	50V M.C.	2D
C1	0601136	50V M.C.	2D

Part No.	Stock No.	Description	Position
R15	0106152	1.5kΩ	1A
R14	0106399	39kΩ	1A
R13	0107222	2.2kΩ	1A
R12	0106102	1.1kΩ	1A
R11	0106471	4.7kΩ	1A
R10	0107221	220Ω	1A
R9	0106532	3.3kΩ	1A
R8	0106152	1.5kΩ	1A
R7	0106102	1.1kΩ	1A
R6	0107220	22kΩ	1A
R5	0106101	1.0kΩ	1A
R4	0106532	3.3kΩ	1A
R3	0106102	1.1kΩ	1A
R2	0107220	22kΩ	1A
R1	0106399	39kΩ	1A

Part No.	Stock No.	Description	Position
R27	0106472	4.7kΩ	2B
R26	0106102	1.1kΩ	2B
R25	0107103	10kΩ	2B
R24	0107220	22kΩ	2B
R23	0106532	3.3kΩ	2B
R22	0106152	1.5kΩ	2B
R21	0106102	1.1kΩ	2B
R20	0107222	22kΩ	2B
R19	0106472	4.7kΩ	2B
R18	0106102	1.1kΩ	2B
R17	0106532	3.3kΩ	2B
R16	0106102	1.1kΩ	2B
R15	0107221	220Ω	2B
R14	0106532	3.3kΩ	2B
R13	0106102	1.1kΩ	2B
R12	0106102	1.1kΩ	2B
R11	0106532	3.3kΩ	2B
R10	0106102	1.1kΩ	2B
R9	0106532	3.3kΩ	2B
R8	0106102	1.1kΩ	2B
R7	0106532	3.3kΩ	2B
R6	0106102	1.1kΩ	2B
R5	0106532	3.3kΩ	2B
R4	0106102	1.1kΩ	2B
R3	0107122	1.2kΩ	2B
R2	0106399	39kΩ	2B
R1	0106532	3.3kΩ	2B

Part No.	Stock No.	Description	Position
R60	0107182	6.8kΩ	2C
R59	0107182	1.8kΩ	2C
R58	0107473	47kΩ	1,2C
R57	0107473	47kΩ	1D
R56	0106451	150Ω	1D
R55	0106472	4.7kΩ	1,2D
R54	0106451	150Ω	1D
R53	0106451	150Ω	1D
R52	0106451	150Ω	1D
R51	0106451	150Ω	1D
R50	0106451	150Ω	1D
R49	0106451	150Ω	1D
R48	0106451	150Ω	1D
R47	0106451	150Ω	1D
R46	0106451	150Ω	1D
R45	0106451	150Ω	1D
R44	0106451	150Ω	1D
R43	0106451	150Ω	1D
R42	0106451	150Ω	1D
R41	0106451	150Ω	1D
R40	0106451	150Ω	1D
R39	0106451	150Ω	1D
R38	0106451	150Ω	1D
R37	0106451	150Ω	1D
R36	0106451	150Ω	1D
R35	0106451	150Ω	1D
R34	0106451	150Ω	1D
R33	0106451	150Ω	1D
R32	0106451	150Ω	1D
R31	0106451	150Ω	1D
R30	0106451	150Ω	1D
R29	0106451	150Ω	1D
R28	0106451	150Ω	1D
R27	0106451	150Ω	1D
R26	0106451	150Ω	1D
R25	0106451	150Ω	1D
R24	0106451	150Ω	1D
R23	0106451	150Ω	1D
R22	0106451	150Ω	1D
R21	0106451	150Ω	1D
R20	0106451	150Ω	1D
R19	0106451	150Ω	1D
R18	0106451	150Ω	1D
R17	0106451	150Ω	1D
R16	0106451	150Ω	1D
R15	0106451	150Ω	1D
R14	0106451	150Ω	1D
R13	0106451	150Ω	1D
R12	0106451	150Ω	1D
R11	0106451	150Ω	1D
R10	0106451	150Ω	1D
R9	0106451	150Ω	1D
R8	0106451	150Ω	1D
R7	0106451	150Ω	1D
R6	0106451	150Ω	1D
R5	0106451	150Ω	1D
R4	0106451	150Ω	1D
R3	0106451	150Ω	1D
R2	0106451	150Ω	1D
R1	0106451	150Ω	1D

Abbreviations

C.R. : Carbon Resistor
 S.R. : Solid Resistor
 Ce.R. : Ceramic Resistor
 M.R. : Metalized Resistor
 M.C. : Mylar Capacitor
 E.C. : Electrolytic Capacitor

B.P.E.C. : Bipolar Electrolytic
 C.C. : Ceramic Capacitor
 M.C. : Mica Capacitor
 O.C. : Oil Capacitor
 P.C. : Polyester Capacitor
 T.C. : Tantalum Capacitor

6-4. F-1492 Vario-Matrix Circuit Board (Stock No. 7690170 Complete Circuit Board F-1492)
Conductor Side

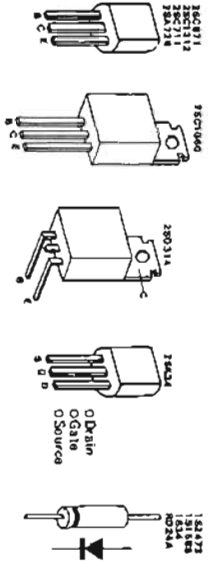
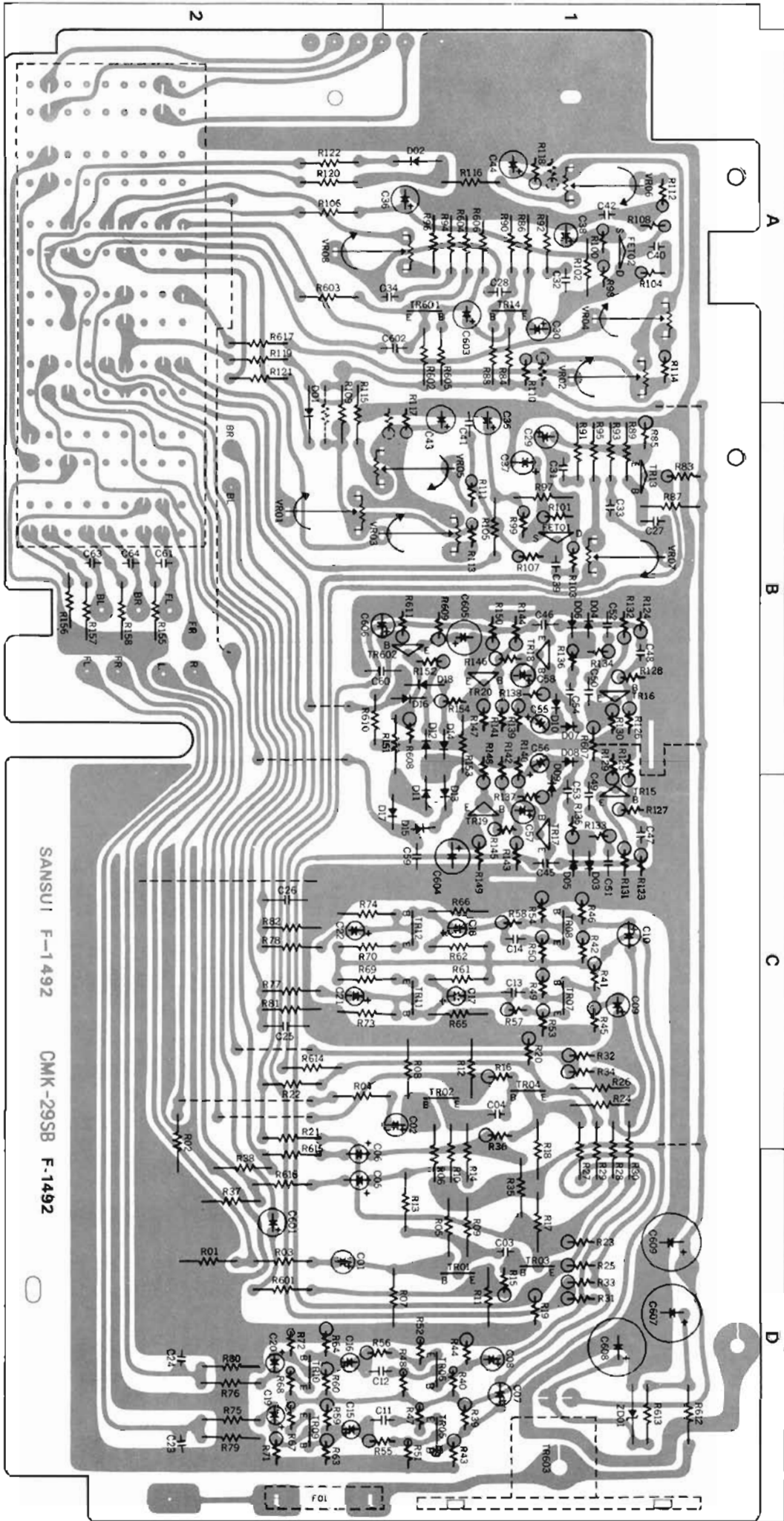

- Abbreviations:**
- C.R. : Carbon Resistor
 - S.R. : Solid Resistor
 - Co.R. : Cement Resistor
 - M.R. : Metallized Film Resistor
 - M.C. : Mylar Capacitor
 - E.C. : Electrolytic Capacitor
 - BP.E.C. : Bipolar Electrolytic Capacitor
 - C.C. : Ceramic Capacitor
 - M.I.C. : Mica Capacitor
 - O.C. : Oil Capacitor
 - P.C. : Polystyrene Capacitor
 - T.C. : Tantalum Capacitor

Parts List

Parts No.	Stock No.	Description	Position	Parts No.	Stock No.	Description	Position	
TR01, 02	0305475	2SC 871® (F)	1 D. 1 C	C19, 20	0519103	0.47 μ F	50V E.C. 2 D	
	or	or		C21, 22	0519103	0.47 μ F		2 C
TR03, 04	0306090	2SC1312® (F)	1 D. 1 C	C23, 24	0601106	0.001 μ F	2 D	
	or	or		C25, 26	0601106	0.001 μ F	50V M.C. 2 C	
TR05	0305475	2SC 871® (F)	1 D	C27, 28	0601477	0.047 μ F	1 B. 1 A	
	or	or		C29, 30	0513479	4.7 μ F	25V E.C. 1 B. 1 A	
TR06, 07	0300410	2SA 726® (F)	1 D	C31, 32	0601397	0.039 μ F	50V M.C. 1 B. 1 A	
	or	or		C33, 34	0620681	680pF	50V P.C. 1B, 1, 2A	
TR08	0305475	2SC 871® (F)	1 D. 1 C	C35, 36	0513100	10 μ F	25V E.C. 1 B. 1 A	
	or	or		C37, 38	0513479	4.7 μ F	1 B. 1 A	
TR09, 10	0300410	2SA 726® (F)	2 D	C39, 40	0601226	0.0022 μ F	1 B. 1 A	
TR11, 12	0305475	2SC 871® (F)	1 C	C41	0601397	0.039 μ F	50V M.C. 1 B	
	or	or		C42	0601186	0.0018 μ F	1 A	
TR13, 14	0306090	2SC1312® (F)	1 B. 1 A	C43, 44	0513100	10 μ F	25V E.C. 1 B. 1 A	
	or	or		C45, 46	0601106	0.001 μ F	1 C. 1 B	
TR15, 16	0305731	2SC 711 (F)	1 C. 1 B	C47, 48	0601206	0.002 μ F	1 C. 1 B	
TR17, 18	0305731	2SC 711 (F)	1 C. 1 B	C49, 50	0601477	0.047 μ F	50V M.C. 1 C. 1 B	
TR19, 20	0305732	2SC 711 (F)	1 C. 1 B	C51, 52	0601206	0.002 μ F	1 C. 1 B	
	or	or		C53, 54	0601477	0.047 μ F	1 C. 1 B	
TR601	0305475	2SC 871® (F)	1 A	C55, 56	0573228	0.22 μ F	25V T.C. 1 B	
	or	or		C57, 58	0513479	4.7 μ F	25V E.C. 1 C. 1 B	
TR602	0306090	2SC1312® (F)	1 B	C59, 60	0601477	0.047 μ F	1 C. 1, 2B	
	or	or		C61, 62	0601227	0.022 μ F	50V M.C. 2 B	
TR603	0305732	2SC 711 (F)	1 D	C63, 64	0601227	0.022 μ F	2 B	
	or	or		C65, 66	0620181	180pF	50V P.C.	
FET01, 02	0370140, 1	2SK34 (D, E)	FET	C67, 68	0620181	180pF		
D01, 02	0311160	1S2473	2AB. 1A	C601	0513100	10 μ F	25V E.C. 2 D	
	or	or		C602	0601476	0.0047 μ F	50V M.C. 1, 2 A	
D03, 04	0311180	1S1588	1 C. 1 B	C603	0519102	3.3 μ F	50V E.C. 1 A	
D05, 06	0311190	1S34		C604	0510101	100 μ F	6.3V E.C. 1 C	
D07, 08	0311190	1S34	1 C. 1 B	C605	0510101	100 μ F	1 B	
	or	or		C606	0513479	4.7 μ F	25V E.C. 1, 2 B	
D09, 10	0311160	1S2473	1 B	C607	0515101	100 μ F	50V E.C. 1 D	
	or	or		C608	0513221	220 μ F	25V E.C. 1 D	
D11, 12	0311180	1S1588	1 C. 1 B	C609	0513221	220 μ F	1 D	
	or	or		R01, 02	0107104	100k Ω	2D, 2CD	
D13, 14	0311160	1S2473	1 C. 1 B	R03, 04	0107222	2.2k Ω	2D, 1, 2C	
	or	or		R05, 06	0107224	220k Ω	1D, 1CD	
D15, 16	0311180	1S1588	1 C. 1 B	R07, 08	0107104	100k Ω	1/4 W C.R. 1 D. 1 C	
	or	or		R09, 10	0107222	2.2k Ω	1D, 1CD	
D17, 18	0311160	1S2473	1 C. 1 B	R11, 12	0107222	2.2k Ω	1D, 1 C	
	or	or		R13, 14	0107224	220k Ω	1D, 1CD	
ZD01	0315420	RD24A (N)	Zener Diode	1 D	R15, 16	0106223	22k Ω	1/4 W C.R. 1 D. 1 C
C01, 02	0519103	0.47 μ F	50V E.C.	2 D. 1 C	R17, 18	0107152	1.5k Ω	1/4 W C.R. 1D, 1CD
C03, 04	0601107	0.01 μ F	50V M.C.	1 D. 1 C	R19, 20	0106152	1.5k Ω	1/4 W C.R. 1 D. 1 C
C05, 06	0573108	0.1 μ F	25V T.C.	2D, 2DC	R21, 22	0107224	220k Ω	1/4 W C.R. 2 C
C07, 08	0515109	1 μ F	50V E.C.	1 D	R23	0106104	100k Ω	1/4 W C.R. 1 D
C09, 10	0515109	1 μ F	50V E.C.	1 C	R24	0107104	100k Ω	1/4 W C.R. 1 C
C11, 12	0601607	0.06 μ F	50V M.C.	1, 2 D	R25	0106104	100k Ω	1/4 W C.R. 1 D
C13, 14	0601126	0.0012 μ F	50V M.C.	1 C	R26	0107104	100k Ω	1 C
C15, 16	0519103	0.47 μ F	50V E.C.	2 D	R27, 28	0107104	100k Ω	1/4 W C.R. 1 C, D
C17, 18	0519103	0.47 μ F	50V E.C.	1 C	R29, 30	0107104	100k Ω	1 C, D
					R31, 32	0106563	56k Ω	1/4 W C.R. 1D, 1C
					R33, 34	0106563	56k Ω	(E.L.R.) 1D, 1C
					R35	0107224	220k Ω	1/4 W C.R. 1 D
					R36	0106224	220k Ω	1/4 W C.R. 1 C
					R37, 38	0107474	470k Ω	(E.L.R.) 1/4 W C.R. 2 D

to be continued

F-1492 Parts List

Parts No.	Stock No.	Description	Position	Parts No.	Stock No.	Description	Position
R39	0106104	100kΩ	1 D	R131, 132	0106103	10kΩ	1/4 W C.R. (E.L.R.)
R40	0106224	220kΩ	1 D	R133, 134	0106472	4.7kΩ	
R41	0106224	220kΩ	1 C	R135, 136	0106472	4.7kΩ	
R42	0106104	100kΩ	1 C	R137, 138	0110685	6.8MΩ	1/4 W S.R.
R43	0106224	220kΩ	1 D	R139, 140	0106333	33kΩ	1 B, 1 B C
R44	0106104	100kΩ	1 D	R141	0106104	100kΩ	1 B
R45	0106104	100kΩ	1 C	R142	0106224	220kΩ	1 B C
R46	0106224	220kΩ	1/4 W C.R. (E.L.R.)	R143	0106153	15kΩ	1/4 W C.R. (E.L.R.)
R47, 48	0106682	6.8kΩ		1 D	R144	0106333	
R49, 50	0106682	6.8kΩ	1 C	R145, 146	0106123	12kΩ	1 C, 2 B
R51, 52	0106682	6.8kΩ	1 D	R147, 148	0106472	4.7kΩ	1 B, 1 B C
R53, 54	0106682	6.8kΩ	1 C	R149, 150	0106102	1kΩ	1 C, 2 B
R55, 56	0106223	22kΩ	1, 2 D	R151	0107104	100kΩ	1/4 W C.R.
R57, 58	0106153	15kΩ	1 C	R152	0106104	100kΩ	1/4 W C.R. (E.L.R.)
R59, 60	0106394	390kΩ	2 D	R153	0107104	100kΩ	1/4 W C.R.
R61, 62	0107394	390kΩ	1/4 W C.R.	R154	0106104	100kΩ	1/4 W C.R. (E.L.R.)
R63, 64	0106824	820kΩ	1/4 W C.R. (E.L.R.)	R155, 156	0107333	33kΩ	2 B
R65, 66	0107824	820kΩ	1/4 W C.R.	R157, 158	0107333	33kΩ	2 B
R67, 68	0106102	1kΩ	1/4 W C.R. (E.L.R.)	R601	0107822	8.2kΩ	2 D
R69, 70	0107102	1kΩ	1/4 W C.R.	R602	0107152	1.5kΩ	1/4 W C.R.
R71, 72	0106272	2.7kΩ	1, 2 C	R603	0107472	4.7kΩ	
R73, 74	0107272	2.7kΩ	1, 2 C	R604	0107152	1.5kΩ	1 A
R75, 76	0107222	2.2kΩ		2 D	R605	0107224	220kΩ
R77, 78	0107222	2.2kΩ	1/4 W C.R.	R606	0107104	100kΩ	1 A
R79, 80	0107105	1MΩ	2 D	R607	0106105	1MΩ	1 B
R81, 82	0107105	1MΩ	2 C	R608	0106472	4.7kΩ	1/4 W C.R. (E.L.R.)
R83	0106472	4.7kΩ	1/4 W C.R. (E.L.R.)	R609	0106102	1kΩ	2 B
R84	0107472	4.7kΩ	1/4 W C.R.	R610	0107224	220kΩ	1/4 W C.R.
R85	0106222	2.2kΩ	1/4 W C.R. (E.L.R.)	R611	0106333	33kΩ	1/4 W C.R. (E.L.R.)
R86	0107272	2.7kΩ	1 A	R612	0107152	1.5kΩ	1 D
R87	0107184	180kΩ	2 B	R613	0107152	1.5kΩ	1 D
R88	0107154	150kΩ	1 A	R614	0107479	4.7Ω	1/4 W C.R.
R89, 90	0107473	47kΩ	1/4 W C.R.	R615	0107479	4.7Ω	
R91, 92	0107151	150Ω		2 B, 1 A	R616	0107479	4.7Ω
R93, 94	0107153	15kΩ	2 B, 1 A	R617	0107479	4.7Ω	2 A
R95, 96	0107153	15kΩ	2 B, 1 A	VR01	1032490	20kΩ (B)	2 B
R97	0107153	15kΩ	2 B	VR02	1032490	20kΩ (B)	1 A
R98	0106153	15kΩ	1 A	VR03	1032490	20kΩ (B)	1, 2 B
R99, 100	0106123	12kΩ	1/4 W C.R. (E.L.R.)	VR04	1032490	20kΩ (B)	Semi-Variable Resistor
R101	0106333	33kΩ		2 B	VR05	1032560	
R102	0107333	33kΩ	1/4 W C.R.	VR06	1032560	1MΩ (B)	1 A
R103, 104	0106105	1MΩ	1/4 W C.R. (E.L.R.)	VR07	1032520	100kΩ (B)	1 B
R105, 106	0107103	10kΩ	1/4 W C.R.	VR08	1032520	100kΩ (B)	1, 2 A
R107, 108	0106105	1MΩ	1/4 W C.R. (E.L.R.)	S01 (a~c)	1130800	Push Switch (7 Stage)	
R109	0107682	6.8kΩ	1/4 W C.R.		2410570	5P Connector	
R110	0106682	6.8kΩ	1 A				
R111, 112	0106334	330kΩ	1/4 W C.R. (E.L.R.)				
R113, 114	0106101	100Ω		2 B, 1 A			
R115, 116	0107474	470kΩ	1/4 W C.R.				
R117, 118	0106183	18kΩ	1/4 W C.R. (E.L.R.)				
R119, 120	0107224	220kΩ	1/4 W C.R.				
R121, 122	0107564	560kΩ		2 A			
R123, 124	0106683	68kΩ	1 C, 2 B				
R125, 126	0106105	1MΩ	1/4 W C.R. (E.L.R.)				
R127, 128	0106224	220kΩ		1 B C, 2 B			
R129, 130	0106223	22kΩ	1/4 W C.R. (E.L.R.)				

Abbreviations

C.R. : Carbon Resistor	BP.E.C.: Bi-Polar Electrolytic Capacitor
S.R. : Solid Resistor	C.C. : Ceramic Capacitor
Ce.R. : Cement Resistor	M.I.C. : Mica Capacitor
M.R. : Metallized Film Resistor	O.C. : Oil Capacitor
M.C. : Mylar Capacitor	P.C. : Polystyrene Capacitor
E.C. : Electrolytic Capacitor	T.C. : Tantalum Capacitor

6-5. F-1495 Driver Circuit Board (Stock No. 7570820 Complete Circuit Board F-1495)

Conductor Side

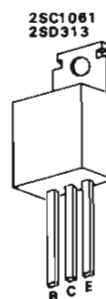
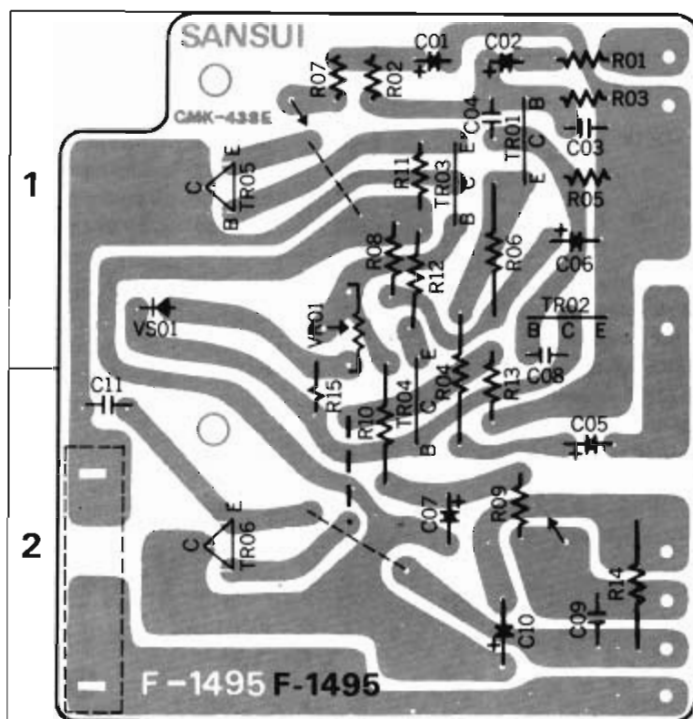

Parts List

Parts No.	Stock No.	Description	Position
TR01	0300410	2SA726® (F)	1
TR02	0306131, 2	2SC1364 (6, 7)	1
TR03	0306131, 2	2SC1364 (6, 7)	1
TR04	0300291, 2	2SA678A (6, 7)	1, 2
TR05,06	0305771, 2	2SC1061 (B, C)	1, 2
	or	or	
	0308391, 2	2SD313 (D, E)	
VS01	0340110	SV03F Varistor	1
C01	0515100	10 μ F	1
C02	0519103	0.47 μ F	1
C03	0660470	47 pF	1
C04	0660470	47 pF	1
C05	0513101	100 μ F	2
C06	0512101	100 μ F	1
C07	0515470	47 μ F	2
C08	0660470	47 pF	1
C09	0657223	0.022 μ F	2
C10	0513471	470 μ F	2
C11	0657223	0.022 μ F	2
R01	0106103	10k Ω	1
R02	0106274	270 Ω	1
R03	0106224	220k Ω	1
R04	0107221	220 Ω	1, 2
R05	0106182	1.8k Ω	1

Parts No.	Stock No.	Description	Position
R06	0107181	180 Ω	1
R07	0106683	68k Ω	1
R08	0106123	12k Ω	1
R09	0106102	1k Ω	2
R10	0107332	3.3k Ω	1, 2
R11	0106221	220 Ω	1
R12	0106330	33 Ω	1
R13	0106221	220 Ω	1, 2
R14	0107471	470 Ω	2
R15	0107102	1k Ω	1, 2
VR01	1031410, 1	200 Ω (B) Semi-Variable Resistor	1
F01	0433610	2A 125V Quick Acting Fuse	
	0433660	1.5A 250V Quick Acting Fuse (CSA Model Only)	

6-6. Other Parts (Front Side)

Parts List

Parts No.	Stock No.	Description
1	5101165	Binding Head Screw, M4 × 14
2	5186110	Plain Washer, 4φ
3	5101165	Binding Head Screw, M × 14
4	5186110	Plain Washer, 4φ
5	5726850	Wood Bonnet
6	5176052	Jack Nut
7	5176052	Jack Nut
8	5317760	W1-2 Type Knob, BASS volume
9	5317671	WO-1 Type Knob, BASS volume
10	5317760	W1-2 Type Knob, TREBLE volume
11	5317671	WO-1 Type Knob, TREBLE volume
12	5317760	W1-2 Type Knob, BALANCE volume
13	5317671	WO-1 Type Knob, BALANCE volume
14	5317830	W1-3 Type Knob, VOLUME
15	5317840	WO-2 Type Knob, VOLUME
16	5326420	Push Button
17	5326420	Push Button
18	5326420	Push Button
19	5326420	Push Button
20	5326420	Push Button
21	5326420	Push Button
22	5326420	Push Button
23	5317730	M-3 Type Knob, SELECTOR
24	5317820	T-6 Type Knob, TUNING
25	5176011	A Type Nut
26	5102843	Flat Countersunk Head Screw, M3 × 6
27	5102843	Flat Countersunk Head Screw, M3 × 6
28	{ 5308980	Front Panel
	{ 5047720	Smoked Plate
29	6906031	Spring, POWER switch
30	7106083	Push Button, POWER switch
31	1130350	Push Switch, POWER
32	2430210	Headphone Jack
33	1060310	5kΩ(C) × 4 BASS volume
34	1060310	5kΩ(C) × 4 TREBLE volume
35	1060300	250kΩ(MN) × 4 BALANCE volume
36	1060290	250kΩ(B) × 4 VOLUME
37	1130800	Push Switch (7 Stage)
38	5109122	Binding Head Screw, 3 × 8
39	5109122	Binding Head Screw, 3 × 8
40	5246470	Mounting Plate, Front Panel
41	1102540	Rotary Switch Y-2-5-4, SELECTOR
42	7036390	Tuning Ass'y
43	5407570	Dial Scale
44	5416370	Dial Pointer
45	5109121	Binding Head Screw, 3 × 6
46	5269460	Holder, signal meter
47	7726050	Meter Lamp Ass'y
48	0420040	Fuse Type Lamp (7V 300mA)
49	4300610	Signal Meter
50	5109122	Binding Head Tapping Screw, 3 × 8
51	5109122	Binding Head Tapping Screw, 3 × 8
52	0400390	Lead Type Lamp (6V 30mA), STEREO Indicator
53	0400310	Lead Type Lamp (7V 100mA), 2-CH Indicator
54	0400310	Lead Type Lamp (7V 100mA), 4-CH Indicator
55	5066210	Illuminator Box
56	0420040	Fuse Type Lamp (7V 300mA)
57	5101165	Binding Head Screw, M4 × 14

Parts No.	Stock No.	Description
58	5516911	Rubber Foot
59	5101165	Binding Head Screw, M4 × 14
60	5516911	Rubber Foot
61	5109222	Binding Head Tapping Screw, 3 × 8
62	5109222	Binding Head Tapping Screw, 3 × 8
63	5058160	Bottom Plate

- ① ~ ③① ●
- ③① ~ ③① ●
- ~ ③① ●

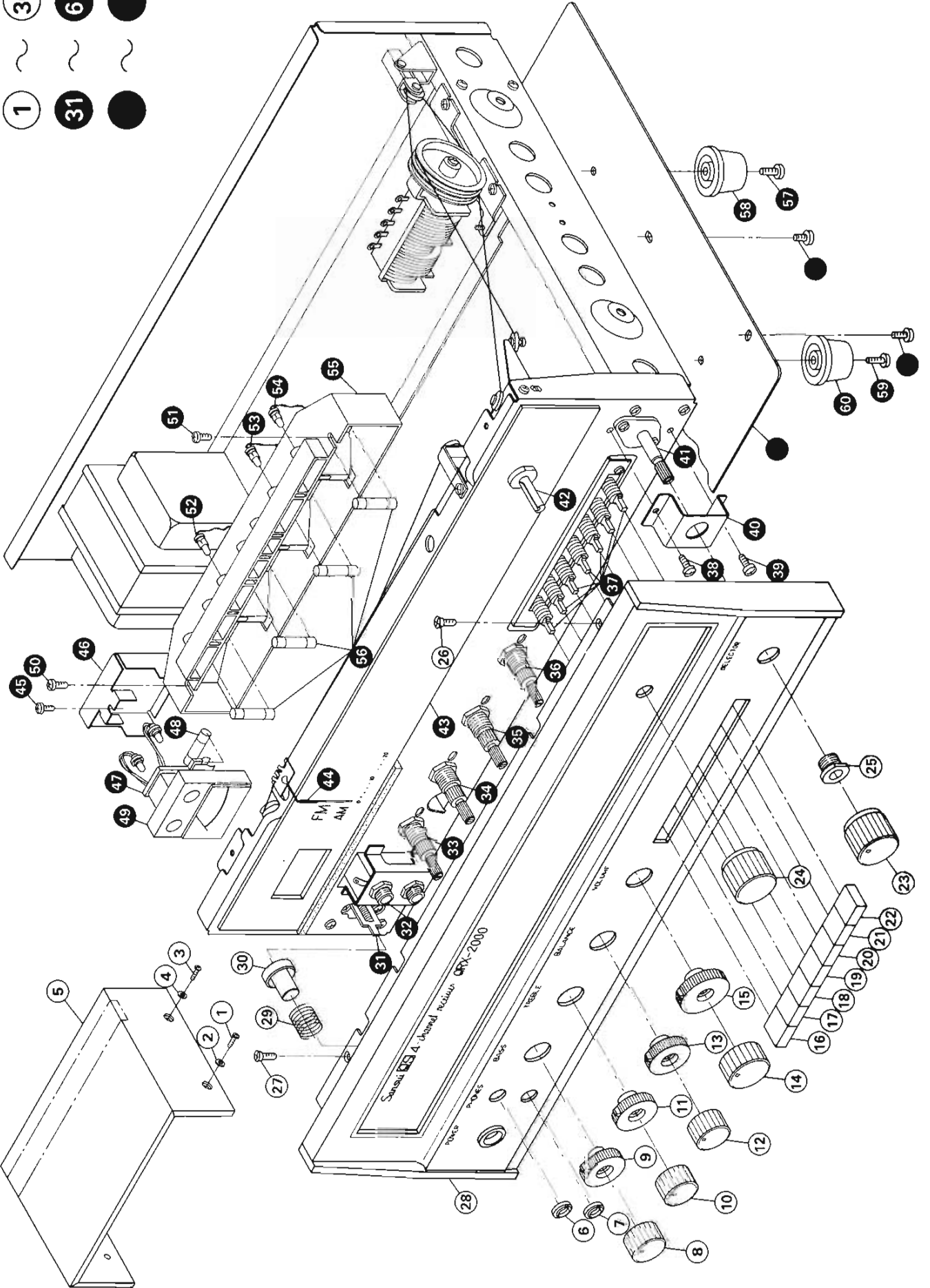

6-7. Other Parts (Top Side)

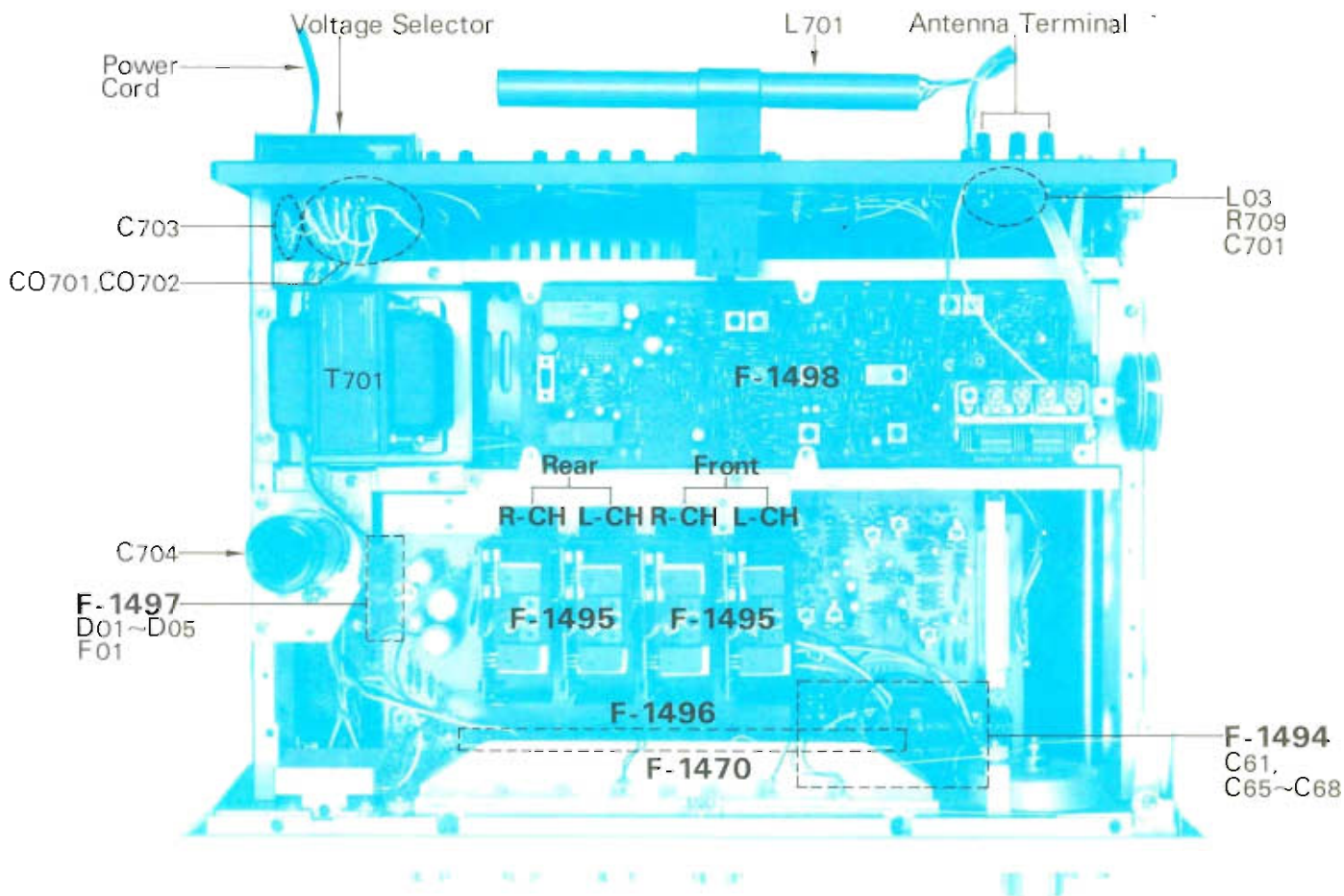

Top Side Parts List

Parts No.	Stock No.	Description
	7591970	F-1494 Switch Circuit Board Ass'y
C61	0601227	0.022 μ F 50V M.C.
C65	0620181	180pF
C66	0620181	180pF
C67	0620181	180pF
C68	0620181	180pF
	7591980	F-1497 Fuse Circuit Board Ass'y
D01	0310960	S 1.5-02
D02	0310960	S 1.5-02
D03	0310960	S 1.5-02
D04	0410960	S 1.5-02
D05	0310340	10D-1
	or	or
	0310870	SRIFM2
F01	0432890, 1	4A Wired-in Fuse
C701	0660101	100pF 50V C.C.
C703	0605476	0.0047 μ F 250V M.C.
C704	0559322	4700 μ F 50V E.C.
R709	0303122	1.2k Ω 1/2W C.R.
L03	4290110	Choke Coil
L701	4200550	Bar Antenna (ARS-31B)

Parts No.	Stock No.	Description
CO701	2450040	AC Outlet
CO702	2450040	AC Outlet
T701	4001400	Power Transformer
	2410080	Voltage Selector, socket
	2410090	Voltage Selector, plug
	2210190	Antenna Terminal
	3800020	Power Cord (KP-200)

6-8. Other Parts (Bottom Side)

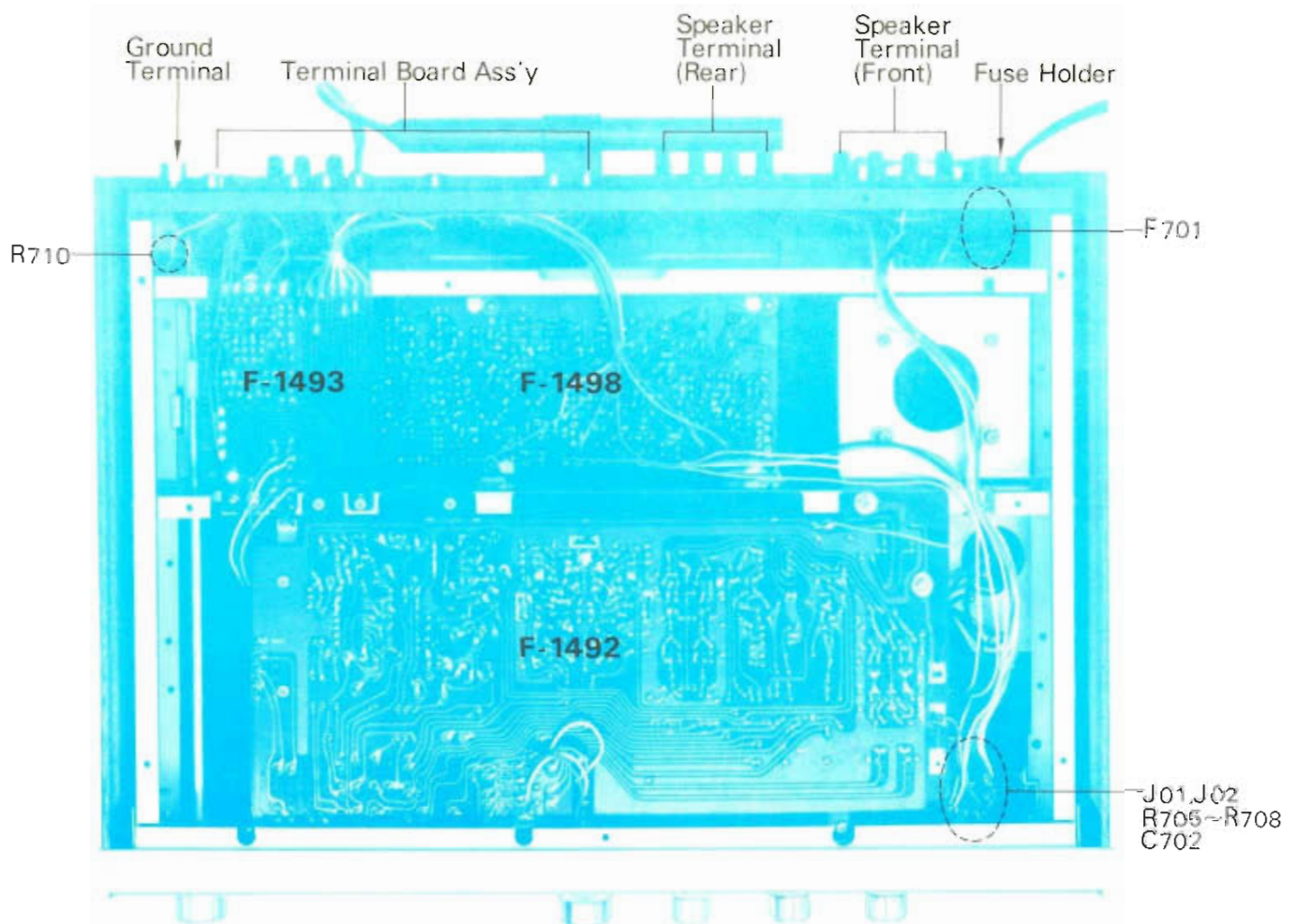

Bottom Side Parts List

Parts No.	Stock No.	Description
C702	0605337	0.033 μ F 250V M.C.
R701	0107104	100k Ω
R702	0107104	100k Ω
R703	0107334	330k Ω
R704	0107334	330k Ω
R705	0103221	220 Ω
R706	0103221	220 Ω
R707	0103221	220 Ω
R708	0103221	220 Ω
R710	0103821	820 Ω
J01, 02	2430210	Phone Jack
F701	0431240	2A Power Fuse (100~117V)
	0431230	1.5A Power Fuse (220~240V)
	2300060	Fuse Holder
	:2210200	4P Speaker Terminal (Front)
	:2210200	4P Speaker Terminal (Rear)
	:7716010	Terminal Board Ass'y
	:2230050	Ground Terminal

Abbreviations

C.R.	: Carbon Resistor	BP.E.C.:	Bi-Polar Electrolytic Capacitor
S.R.	: Solid Resistor	C.C.	: Ceramic Capacitor
Ce.R.	: Cement Resistor	Mi.C.	: Mica Capacitor
M.R.	: Metallized Film Resistor	O.C.	: Oil Capacitor
M.C.	: Mylar Capacitor	P.C.	: Polystyrene Capacitor
E.C.	: Electrolytic Capacitor	T.C.	: Tantalum Capacitor

7. PACKING LIST

Parts No.	Stock No.	Description
1	9017350	Inner Packing (upper)
2	9027723	Stylofoam Packing
3	9007721	Carton Case

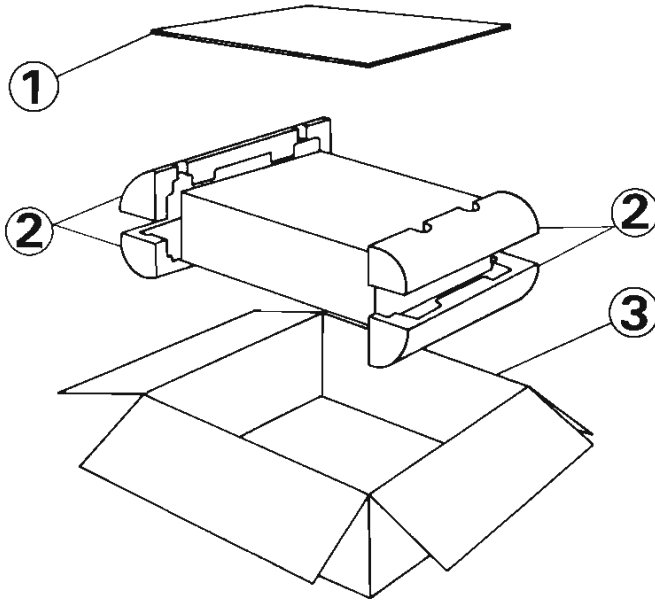

8. ACCESSORY PARTS LIST

Stock No.	Description
9406020	Polishing Cloth
0433610	2A Quick Acting Fuse
9207570	Operating Instructions
9227570	Operating Instruction sheet
3820010	{ FM Antenna AM Antenna

10. SCHEMATIC DIAGRAM OF AUDIO SECTION

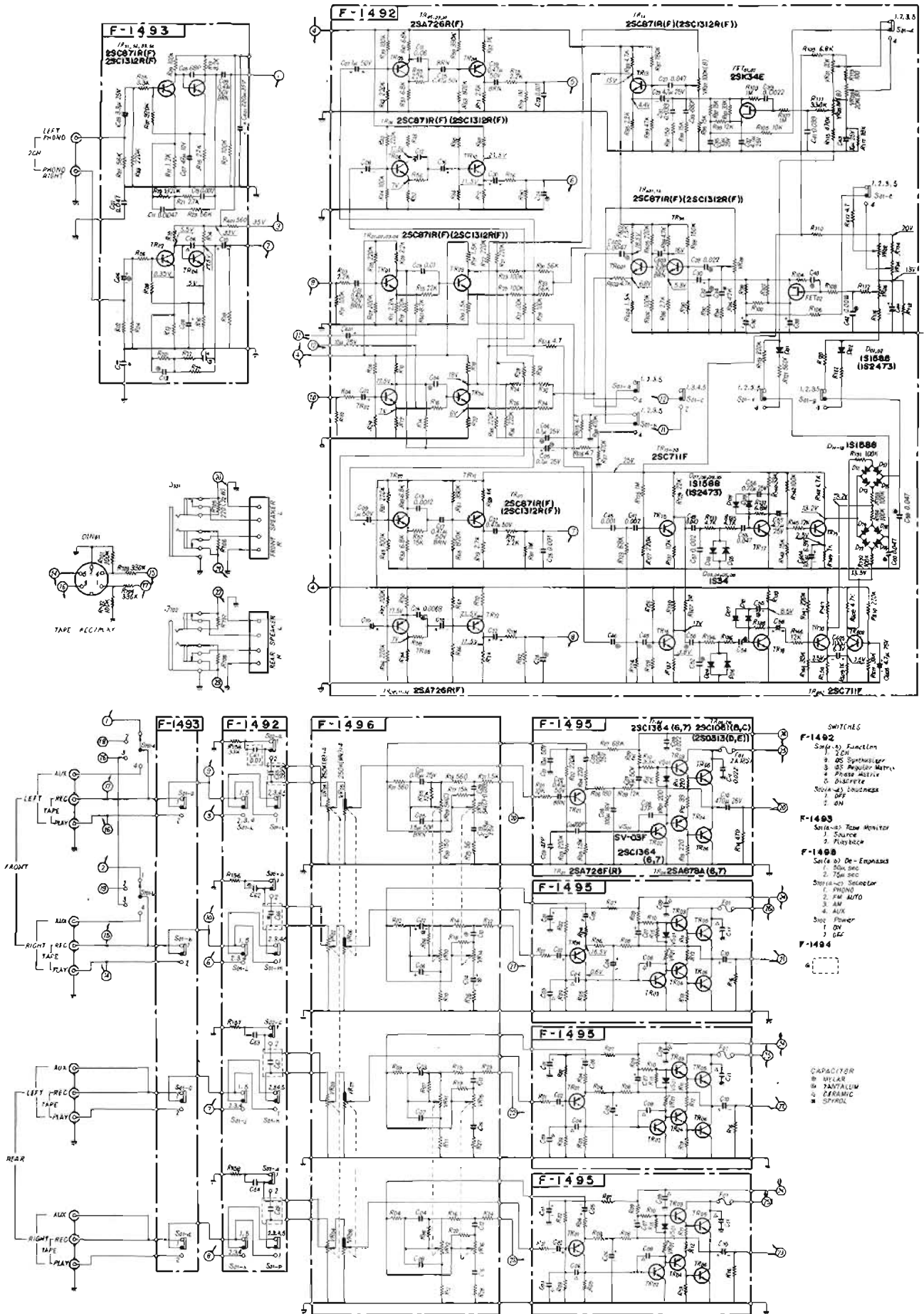



SANSUI ELECTRIC CO., LTD.

14-1, 2-chome, Izumi, Suginami-ku, Tokyo 168, Japan.
TELEPHONE: (03) 323-1111/TELEX: 232-2076