

QS
REGULAR MATRIX

OPERATING INSTRUCTIONS & SERVICE MANUAL

4-CHANNEL RECEIVER

SANSUI QRX-4500

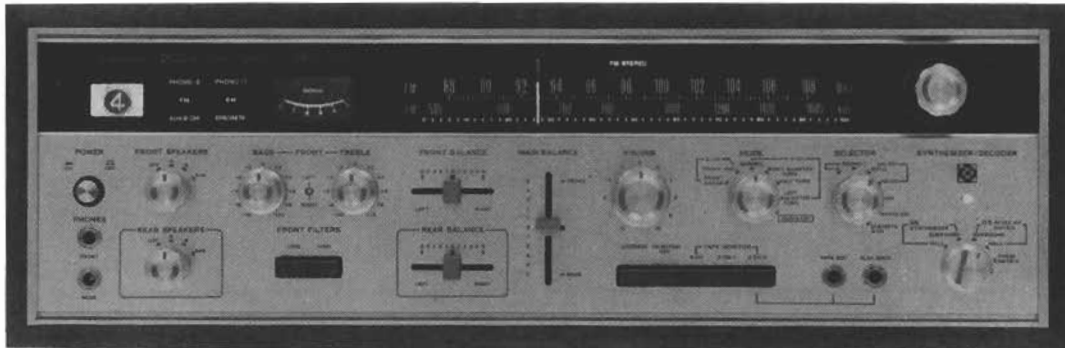

Sansui

SANSUI ELECTRIC CO., LTD.

Congratulations on joining the thousands of proud, satisfied owners of quality stereo components from Sansui.

The QRX-4500 is a 240 watt 4-channel receiver endowed with practically all the features necessary for enjoying every type of music in the new, enthralling 4-channel format. Incorporating the widely-acknowledged Sansui QS REGULAR MATRIX system, it features the exclusive QS Vario-Matrix Circuit, which (1) decodes encoded 4-channel program sources back into 4-channel and (2) transforms (synthesizes) conventional 2-channel sources into 4-channel. It also has complete provisions for reproducing discrete 4-channel sources. And of course, reproduces 2-channel sources in 2-channel stereo if you so desire.

The QRX-4500 connects up to three pairs of speaker systems for the front channels, and two pairs for the rear channels, enabling you to hear the reproduction in two rooms. In addition, it is provided with a Synthesizer/Decoder Function Control and a Mode Switch to let you hear each selection with the most effective sound effect. In short, we have made it one of the most complete, most versatile 4-channel receivers available today.

Now it is up to you to read the instructions contained in this booklet, so that you may take full advantage of its rich performance potential.

Again, welcome to the world of 4-channel stereo, and our sincere gratitude for your choice. You will not be disappointed.

CONTENTS

SWITCHES AND CONTROLS	3~7
TO ENJOY 4-CHANNEL STEREO AT ITS BEST	8
CONNECTING SPEAKER SYSTEMS/PLAYING RECORDS.....	9, 10
RADIO RECEPTION	11, 12
2-CHANNEL TAPE DECKS	13, 14
4-CHANNEL TAPE DECK.....	15, 16
SIMPLE MAINTENANCE HINTS	17, 18
SIMPLE MAINTENANCE HINTS/ACCESSORIES.....	19
SPECIFICATIONS	20
GENERAL TROUBLESHOOTING CHART	21, 22
DISASSEMBLY PROCEDURE	23, 24
TEST POINTS.....	25
SCHEMATIC DIAGRAM OF AUDIO SECTION	26, 27
SCHEMATIC DIAGRAM OF TUNER SECTION	28, 29
ALIGNMENT	30~32
PRINTED CIRCUIT BOARDS AND PARTS LIST	33~45
OTHER PARTS AND THEIR LOCATION ON CHASSIS	46~48



Faded, illegible text, likely bleed-through from the reverse side of the page or a ghost image.

SWITCHES AND CONTROLS

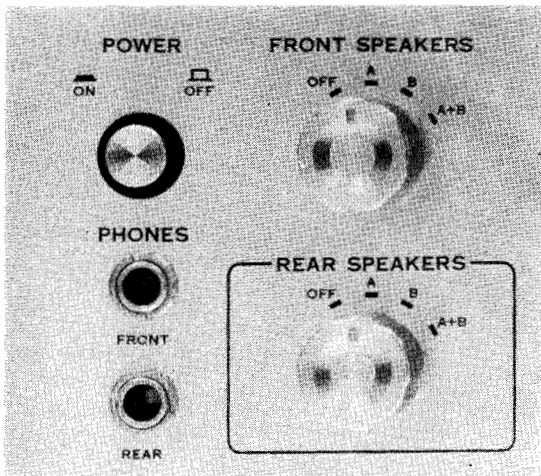
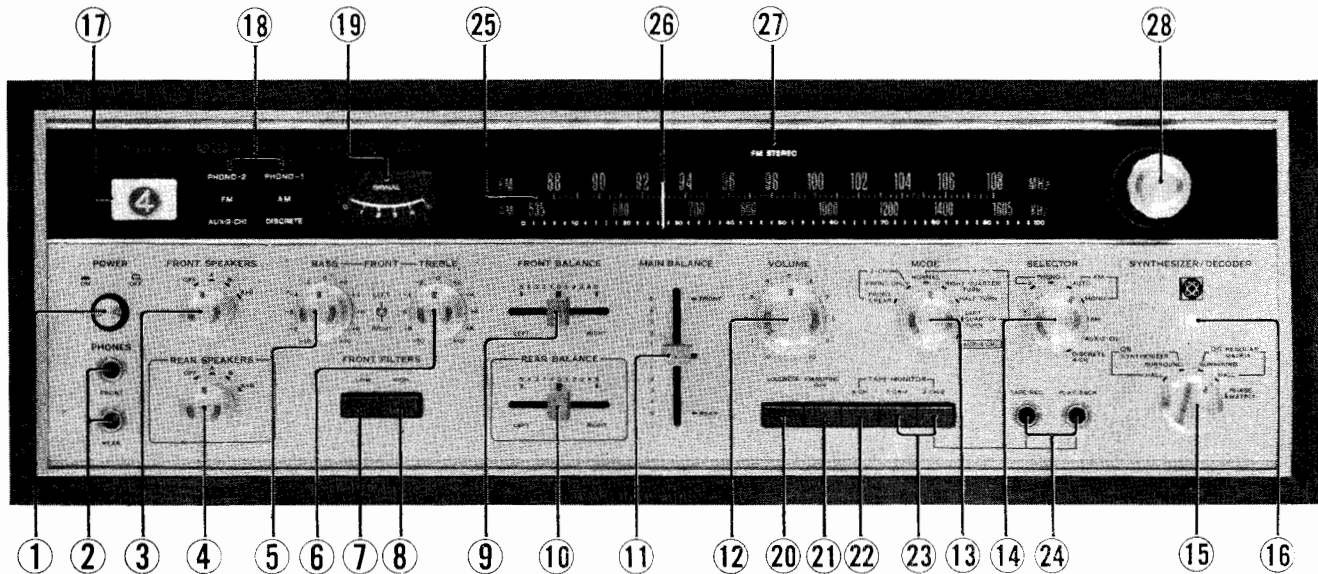

① Power Switch

Turns on and off the power supply for the entire receiver. Push it once to turn on, once more to turn off. It also controls the AC outlet marked SWITCHED on the rear panel.

② Headphone Jacks

Accommodate two stereo headphone sets for monitoring or private listening. The upper jack is for the front channels, and the lower one for the rear. When listening with headphones, turn both the Front and Rear Speakers Switches to 'OFF.' The headphones used should be dynamic types.

③ Front Speakers Switch

The QORX-4500 connects up to two pairs of speaker systems for reproducing the front channel sounds, with this switch allowing either or both pairs to be selected.

OFF: To cut off the sound from the front left and right speaker systems when listening with headphones.

A: To drive the front channel speaker systems connected to the FRONT SYSTEM-A terminals on the receiver's rear panel.

B: To drive the ones connected to the FRONT SYSTEM-B terminals.

A+B: To drive both the A and B pairs.

④ Rear Speakers Switch

The QORX-4500 also connects up to two pairs of speaker systems for the rear channels, with this switch enabling you to choose either or both pairs according to your needs. Use the switch in a manner similar to the Front Speakers Switch.

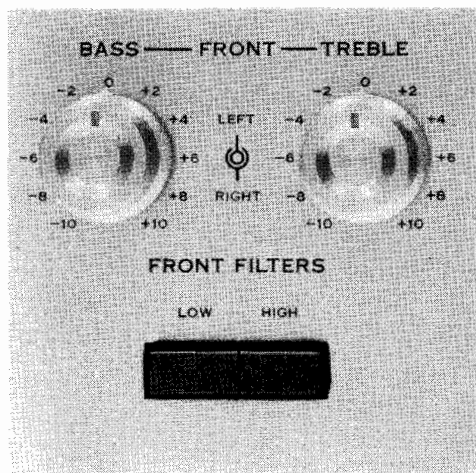

⑤ Front Bass Control

Use to strengthen or weaken the receiver's low-end response according to your personal preference, the frequency response of the speaker systems in use or the acoustics of your room. Turn it clockwise to emphasize the lows in the front channel sounds, counterclockwise to de-emphasize. The inner knob (controlling the front left channel) and the outer knob (controlling the front right channel) are friction-coupled and permit separate or simultaneous adjustment of the two front channels.

⑥ Front Treble Control

Use in the same manner as the above control to adjust the strength of the highs in the front channel sounds.

⑦ Low Filter Switch

Push to eliminate low-frequency noise such as the rumbling of the turntable motor from the front channel sounds. If no such noise is present, be sure to keep the switch off.

⑧ High Filter Switch

Use in the same manner as the above switch to eliminate, from the front channel sounds, such high-frequency noise as the scratch noise produced by a worn record, tape hiss or the whistle noise contained in radio broadcasts. Be sure to keep it off if no such noise exists.

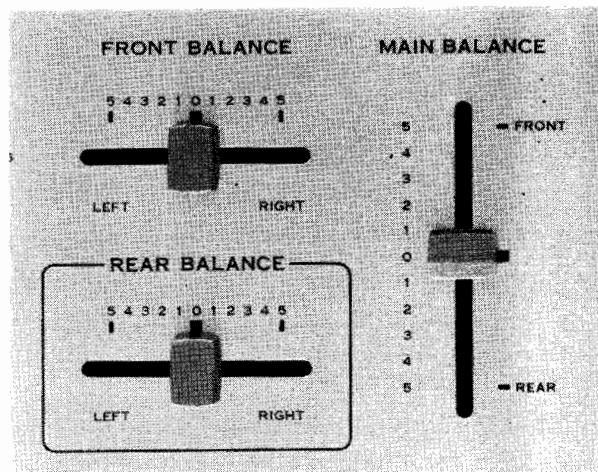

⑨ Front Balance Control

Use to balance the front left and right channels. Slide it to the left to increase the sound volume in the front left channel, to the right to increase that in the front right channel.

⑩ Rear Balance Control

Use in the same manner as the Front Balance Control to balance the rear left and right channels.

⑪ Main Balance Control

Use to balance the front and rear channels. Slide it up to increase the sound volume in the front channels, down to increase that in the rear channels.

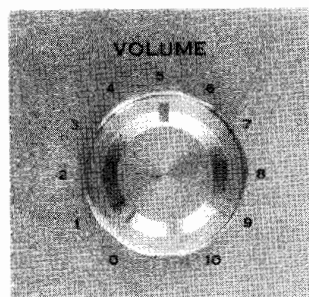

⑫ Volume Control

Use to control the overall sound volume. Turn it clockwise to raise.

SWITCHES AND CONTROLS

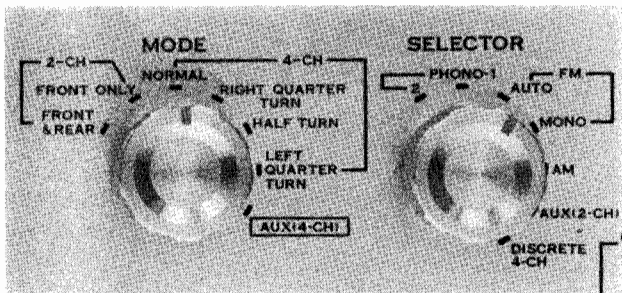

⑬ Mode Switch

Selects between the 2-channel and 4-channel operating modes and among several sub-modes:

2-CH To hear a 2-channel stereo program source connected to the 2-CHANNEL inputs on the rear panel, or if you only have two speakers connected to the QRX-4500.

FRONT & REAR: For reproducing a 2-channel stereo program source simultaneously from both the front and rear speaker systems. The left signal in the stereo program will be reproduced by the front left and rear left speaker systems, and the right signal from the front and rear right speaker systems.

FRONT ONLY: For normal stereo reproduction. Only the front left and right speaker systems will deliver sound to create a normal 2-channel stereo effect.

4-CH To hear 4-channel reproduction.

NORMAL: For normal 4-channel sound reproduction.

RIGHT QUARTER TURN: To turn the sound around by 90 degrees clockwise. The front left and right channel sounds will be heard from the front and rear right speaker systems, and the rear left and right channel sounds from the front and rear left speaker systems. Use this position to obtain a normal 4-channel stereo effect when hearing vocal or other types of program source where the sound is loud only on one side.

HALF TURN: To turn the sound around by 180 degrees, so that the front channel sounds will be heard from the rear channel speaker systems. Used to hear vocal or other types of program source, this position will make the listener feel as if he were right in the middle of the stage.

LEFT QUARTER TURN: To turn the sound around by 90 degrees counterclockwise.

AUX (4-CH): To hear a 4-channel program source connected to the 4-CHANNEL AUX inputs on the rear panel. Note that two sets of 4-CHANNEL AUX inputs are provided, with one set marked LOW and the other HIGH. Connect an ordinary program source to the LOW inputs. If the reproduced sound is distorted or cracked, it is probably because the output level of that particular program source is too high. In which case, move the connections over to the HIGH inputs.

⑭ Selector Control

Depending on what you wish to hear, turn to the appropriate position.

PHONO 2: Selects a turntable connected to the PHONO 2 inputs on the receiver's rear panel.

PHONO 1: Selects the one connected to the PHONO 1 inputs.

FM AUTO: To hear FM broadcasts, whether stereo or mono. When the broadcast signal changes from mono to stereo, the receiver automatically switches itself to stereo reception. The stereo (or encoded 4-channel) broadcast signal may be synthesized or decoded into 4-channel by the built-in QS REGULAR MATRIX system. Adjust the Mode Switch and the Synthesizer/Decoder Function Control properly.

FM MONO: When the receiver is set to FM AUTO and receiving an FM stereo signal, reset the control to this position if the reception should be filled with noise and intolerably unpleasant. The broadcast will then be received in mono but the noise will be substantially reduced.

AM: For receiving AM broadcasts.

AUX (2-CH): To hear whatever 2-channel program source is connected to the 2-CHANNEL AUX inputs on the receiver's rear panel.

DISCRETE 4-CH: To hear whatever discrete 4-channel program source is connected to the 4-CHANNEL DISCRETE inputs. A 4-channel tape deck or a 4-channel adaptor (demodulator) may be connected here.

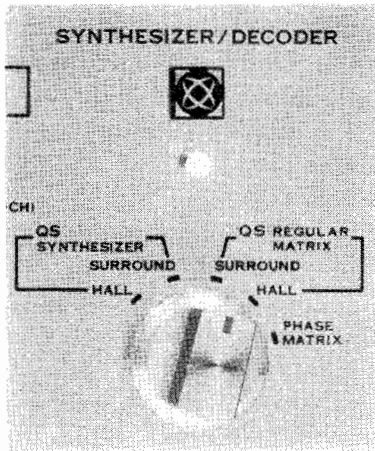

⑮ Synthesizer/Decoder Function Control

Operate this switch to derive the desired sound effect from the built-in QS REGULAR MATRIX circuit, depending on the type of program source. Such sound effect will be further enhanced by employing a proper speaker position (see page 8).

QS SYNTHESIZER For transforming conventional 2-channel stereo program sources into 4-channel sound. Sansui's exclusive 2-4 synthesizing encoder will work in coordination with the QS Vario-Matrix, pre-processing the 2-channel signal for optimum conversion into 4-channel.

HALL: To enjoy the kind of 'presence' you'd feel if you were seated front-and-center in a concert hall, theater or jazz club. The stage will be acoustically reconstructed in front of you, while the sounds reflected by various surfaces in the hall—such as the walls, ceiling, chairs, etc.—will be reproduced in the rear to add depth and the sense of spaciousness.

SURROUND: To drown yourself in the middle of the music. The performing artists will surround you, making you feel as if you were participating.

QS REGULAR MATRIX To decode and reproduce QS-encoded 4-channel program sources (discs and FM broadcasts). The built-in QS Vario-Matrix circuit will retrieve all input information in the original 4-channel recording.

SURROUND: Offers a better-defined, more striking surround effect.

HALL: Reconstructs with greater fidelity, the

sound field originally present in the concert hall, reproducing the artists in the front and the hall ambience in the rear.

PHASE MATRIX To decode and reproduce 4-channel program source (discs and FM broadcasts) encoded by the SQ system. The built-in Sansui-developed Front-Back Logic Circuit will be activated.

⑯ Synthesizer Decoder Indicator

This orange indicator glows to indicate the receiver is operating in a Synthesizer Decoder mode when the Mode Switch is set to a 4-CH position other than AUX (4-CH).

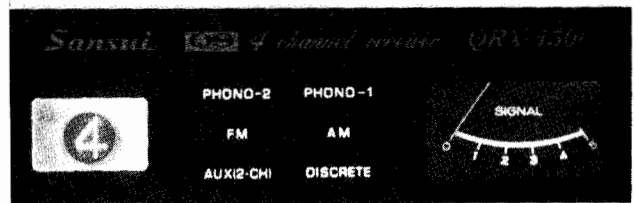

⑰ Digital Indicator

Indicates whether the receiver is operating in the 2- or 4-channel mode. Figure '2' appears when the Mode Switch is set to a 2-channel position, and figure '4' when it is set to a 4-channel position.

⑱ Selector Indicators

When the receiver is turned on, one of these indicators brightly illuminates to show what program source is selected on the Selector Control.

⑲ Signal Meter

Illuminates when FM AUTO, FM MONO or AM is selected on the receiver's Selector Control, and shows the strength of the antenna input signal. The desired station is pinpointed when the pointer of this meter has swung as far to the right as possible.

SWITCHES AND CONTROLS

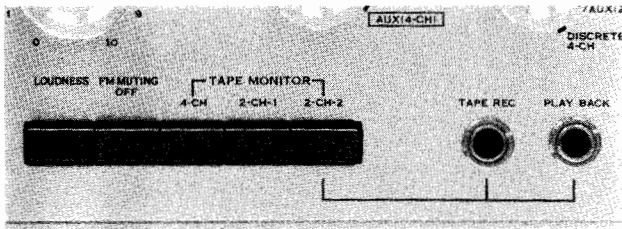

⑳ Loudness Switch

The human ear is such that an apparent 'drop-out' of the lows and highs occurs when you're listening at a low volume level. Pushing this switch compensates for this apparent loss and appropriately accents the lows and highs, in both the front and rear channel sounds simultaneously. You'll thus be able to hear the music in a more natural state.

㉑ FM Muting Release Switch

This switch, if not depressed, eliminates the interstation noise commonly heard when tuning on the FM band. It should be pushed to release the muting function when you are tuning in on a weak FM station.

㉒ 4-Channel Tape Monitor Switch

Push this switch to monitor a tape being recorded by the 4-channel tape deck connected to the 4-channel tape monitor inputs on the receiver's rear panel, or to reproduce a tape so recorded. The monitoring is possible only if the 4-channel tape deck is equipped with separate heads for recording and playback.

At all other times, push the switch once more to restore it to the original position.

㉓ 2-Channel Tape Monitor Switches

These switches control 2-channel tape monitor circuits 1 and 2. Detailed instructions on the operation of such tape decks are given on page 13.

㉔ Tape Deck Jacks

A part of tape monitor circuit 2, these jacks are for connecting a 2-channel tape deck with phone plugs. The left jack is for recording, and the right one for playback. When a tape deck is connected here, the pin jack terminals for tape monitor circuit 2 on the receiver's rear panel is automatically disabled.

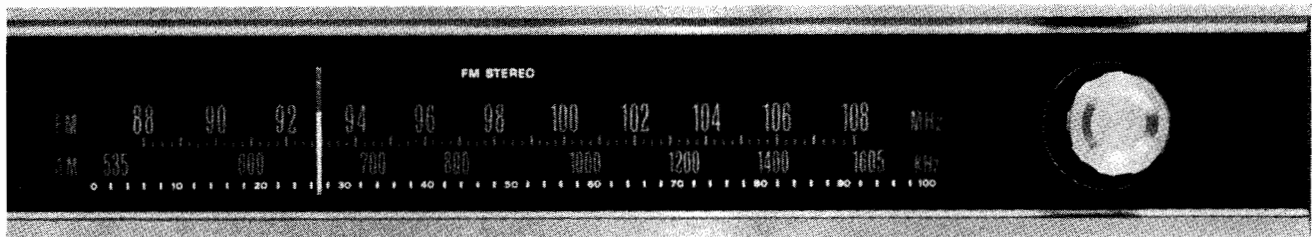

㉕ Dial Scales

Illuminate when either AM, FM AUTO or FM MONO is selected on the Selector Control. The upper scale is for FM, the lower one for AM.

㉖ Dial Pointer

Illuminates in the same manner as the dial scales.

㉗ FM Stereo Indicator

Illuminates when the receiver is tuned in on an FM station broadcasting in stereo.

㉘ Tuning Control

Tune in the receiver on the desired station by turning this control, watching the Signal Meter.

TO ENJOY 4-CHANNEL STEREO AT ITS BEST

The 4-channel system far excels the conventional 2-channel system in its capability to faithfully reproduce the sound field normally present in any live musical performance.

Your QRX-4500 incorporates the now famous Sansui QS REGULAR MATRIX system. Acclaimed world-wide for its technical ingenuity and already standardized in Japan, this system decodes encoded 4-channel program sources back into 4-channel on one hand, and synthesizes conventional 2-channel sources into 4-channel on the other. Both these functions are now accomplished more effectively by the exclusive Sansui QS Vario-Matrix circuit.

Your QRX-4500 also offers complete provisions for connecting and controlling discrete 4-channel sources.

To enjoy 4-channel stereo music at its very best, it is of course important that you know how to use all the controls and switches of the receiver. But a few other useful hints are certain to help you hear the music more effectively, and these will be outlined below.

Selecting and Positioning Speaker Systems

For optimum 4-channel effects, it is always advisable to select speaker systems designed to provide broad sound dispersion (such as the Sansui SF-2 or SF-1 Omni-Radial Sound Field Speaker Systems).

Once they are selected, it is essential that you place them appropriately to suit the type of program source you wish to hear. Remember that the positions of the four speaker systems in a 4-channel stereo system is a vital factor if you are to enjoy 4-channel sound at its very best. Two basic positions will be explained on the right, but you are completely free to adapt them to the particular conditions—both acoustic and physical—of your room.

1) 2-2 System

This is the 4-corner position widely accepted as the 'standard' for 4-channel stereo. While it is particularly good for hearing program sources encoded by a 4-channel encoder, it is also effective for drowning yourself in the middle of the music.

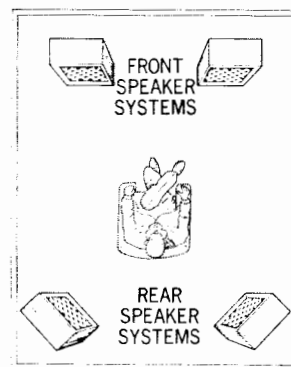

2) Front 2-2 System

This system moves the rear speaker systems up front as shown below and creates a sound field—the equivalent of a concert hall stage—in front of you. It is suitable to enjoy the kind of 'presence' you'd feel if you were seated front-and-center in a concert hall, theater or jazz club.

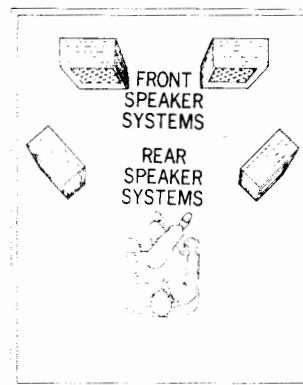

3) Others

Variations of the above two systems are possible, and you are absolutely free to devise one to suit the particular conditions of your room.

CONNECTING SPEAKER SYSTEMS/PLAYING RECORDS

Connecting Speaker Systems

The QRX-4500 connects up to two pairs of speaker systems for the front channels, and another two pairs for the rear. Any pair may be driven independently or a combination of two pairs may be driven, as selected by the Front and Rear Speakers Switches. Connect them to the receiver as instructed in the diagram on the right, taking care not to confuse the front and rear, left and right channels, and the plus and minus polarities. Sufficient care should be taken not to short-circuit the plus and minus leads. As the connecting terminals all adopt Sansui's unique one-touch design, connections can be made simply by pushing the button, inserting the lead wires of the speaker cord, then releasing the button.

About the Speaker Impedance

Each speaker system connected to your QRX-4500 must possess an impedance of from 4 to 16 ohms. Should you wish to drive two pairs of speaker systems simultaneously, they should all have an impedance of 8 ohms or more.

About the Speaker Polarities

Whether or not the four speaker systems in a 4-channel stereo system are in phase with one another is an important factor to the maximum enjoyment of 4-channel stereo sound. The phase relationship must be correct not only between the front left and right speaker systems, and the rear left and right speaker systems, but also between the front channels and rear channels.

When connecting each speaker system to the receiver, be certain to keep the plus and minus polarities in the right order at both ends.

Front & Rear Speakers Switches

If you have two pairs of speaker systems available for use as the rear channel speaker systems, you could place one pair to form the '2-2 System' and the other pair to form the 'Front 2-2 System' of speaker positioning. Then you could operate the Rear Speakers Switch to select either system to suit the particular type of music to be reproduced. Or, you could install four speaker systems in two rooms and enjoy 4-channel stereo music in either room independently or in both rooms simultaneously by the use of the Front and Rear Speaker Switches.

Choice of the Turntable

The turntable connected to the QRX-4500 should be equipped with a magnetic cartridge. The cartridge should be inspected beforehand as to whether the left and right channels are in phase or the left and right channel output voltages are proportionate, or the 4-channel stereo effect could be seriously impaired. Attention should be also paid to whether the stylus is worn out, whether dust is stuck on it or whether the stylus pressure is appropriate or not.

Connecting Turntables

As the QRX-4500 is equipped with two phono input circuits, it is possible to employ two turntables or two tonearms. Connections should be made with shielded cables, taking care not to confuse the left and right channels.

Playing Records

1. Set the receiver's Selector Control to 'PHONO 1' or 'PHONO 2' depending on which input circuit you are using.
2. Turn on the turntable, and adjust it for the right speed.
3. Start playing the record.
4. Set the receiver's Mode Switch to an appropriate position, depending on the type of music being reproduced.
5. Adjust the receiver for optimum sound volume as well as for optimum balance between the front and rear, left and right channels.
6. Operate the receiver's Synthesizer/Decoder Function Control to obtain the desired sound effect.
7. Use the tone controls and other switches and controls according to your personal preference or the room acoustics.

Note: Insert the power cord plug of the turntable into the AC outlet marked SWITCHED on the receiver's rear panel. The power supply for the turntable will then be controlled by the front-panel Power Switch.

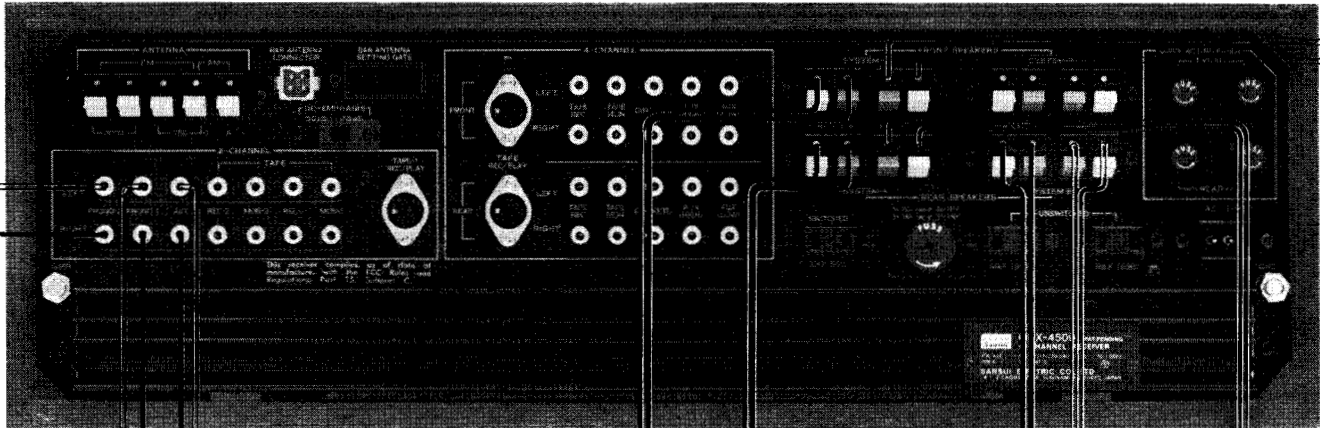

CONNECT OUTPUTS
OF AUXILIARY
COMPONENT



TURNTABLE 1



TURNTABLE 2

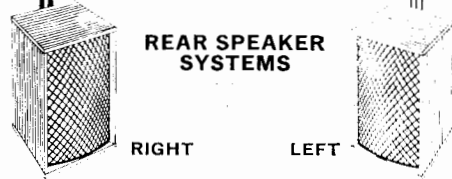

**REAR SPEAKER
SYSTEMS**

RIGHT LEFT

SYSTEM-B



**REAR SPEAKER
SYSTEMS**

RIGHT LEFT

SYSTEM-A

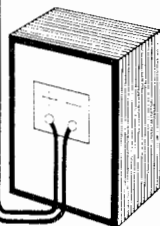

RIGHT

**FRONT SPEAKER
SYSTEMS**

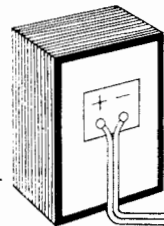

LEFT

SYSTEM-A

Power Cord

The power cord for the QRX-4500 is included in the accessory kit with the other accessories provided with the receiver. Insert the connector end of it into 'AC LINE' socket on the receiver's rear panel.



WALL AC OUTLET

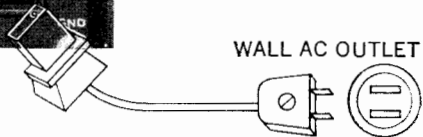

RADIO RECEPTION

Connecting Antennas

The wonderful 4-channel stereo effect would be seriously impaired if considerable noise is mixed with the radio broadcast received by the QRX-4500. As the quality of the reception is largely dependent upon the antennas, be sure to connect them correctly and enjoy noise-free broadcasts.

FM Antenna

T-Shaped Feeder Cable Antenna

If you live in the proximity of broadcast stations where radio waves are able to travel unobstructed, quality reception can be usually achieved by setting up the T-shaped feeder cable antenna supplied with the receiver as illustrated next page, connecting it to the receiver's FM 300 Ω terminals. Set up the receiver for FM reception and stretch the antenna to a full T shape, change its height and direction until the best reception is obtained.

Outdoor FM Antenna

In areas remote from broadcast stations or blocked by such obstacles as mountains and large buildings, the above-mentioned feeder antenna alone may fail to give you quality reception of FM stations. The problem, however, can be usually overcome by installing an outdoor FM antenna. While many different types of antenna are commercially available, we recommend to use one with at least 5 or 7 elements. The antenna is normally connected to the same FM 300 Ω terminals by means of feeder cable, but such cable should be kept as short as possible lest it should pick up noise. Change the height, direction and position of the antenna until you are certain you're receiving the broadcast with the best sensitivity.

If you should need long feeder cable to connect the antenna or where the automobile traffic is heavy, it is advisable to employ 75 Ω coaxial cable. In this case, however, it is necessary to connect a matching transformer between the antenna and the coaxial cable to match their impedances.

The cable should be connected to the FM 75 Ω terminals. (If the antenna itself has an impedance of 75 Ω , no matching transformer is needed.)

AM Antenna

In most areas, clear AM reception is obtained simply by attaching the highly sensitive ferrite bar antenna

supplied with the receiver.

The antenna is kept in the accessory kit together with the other accessories. Take it out and install it, following the directions given below and referring to the diagram.

1. Insert the connector of the antenna into the 'BAR ANTENNA CONNECTOR' on the rear panel.
2. Then insert the bar antenna holder into the 'BAR ANTENNA SETTING GATE'.
3. With the antenna so installed, pull it out forward until the best reception is obtained.

Note: Should you ever need to pack the receiver up, be sure to remove the antenna. This can be achieved by unplugging the connector first, then pulling out the antenna strongly.

Should the bar antenna fail to give you clear reception, however, connect a piece of polyvinyl wire supplied to the AM-A terminal on the receiver's rear panel and stretch it outside a window or on the roof of your home. Still better results would be obtained if you ground the receiver.

Radio Reception

FM Broadcasts

1. Set the Selector Control to 'FM AUTO.'
2. Select the desired FM station by turning the Tuning Control. It is correctly pinpointed when the Signal Meter pointer has swung as far to the right as possible. If the station received is broadcasting in stereo, the Stereo Indicator will illuminate.
3. If unbearably disturbing noise interferes with the reception, reset the Selector Control to 'FM MONO,' and the station will be received monophonically and the noise will be drastically cut down.
4. Operate the various other controls and switches to obtain the best 4-channel stereo effect.

AM Broadcasts

1. Set the Selector Control to 'AM.'
2. Choose the desired station by turning the Tuning Control until the Signal Meter pointer swings as far to the right as it will go near the frequency of that station.
3. Use the various other controls and switches to suit your personal preference or the room acoustics.

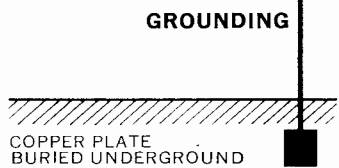
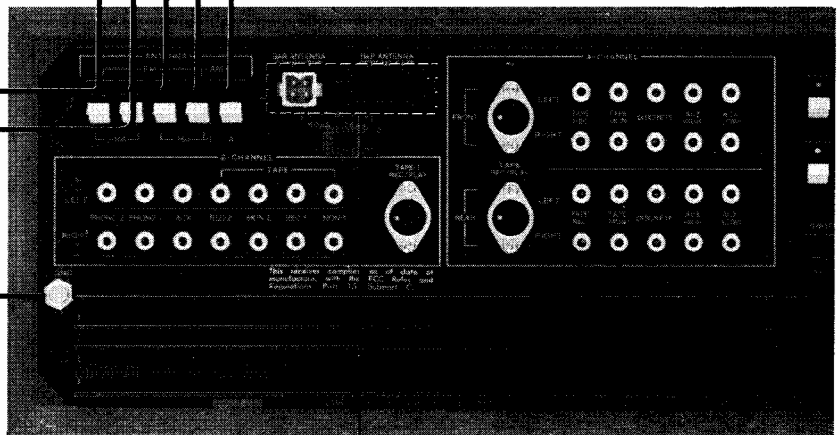
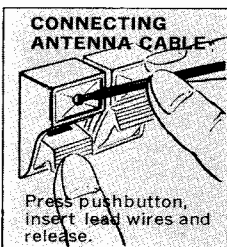
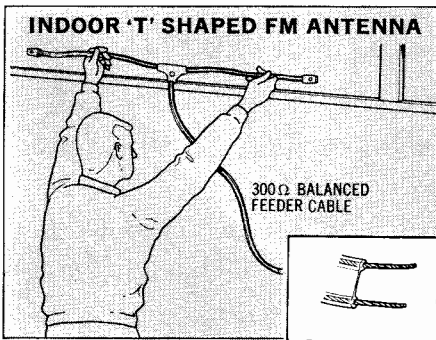
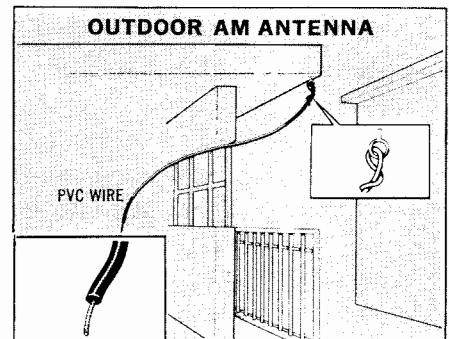
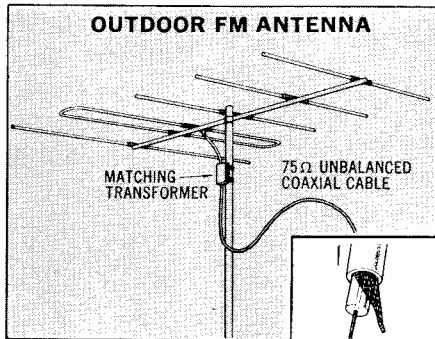
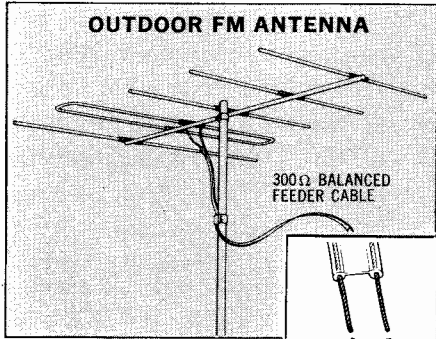

INSTALLING AM FERRITE BAR ANTENNA

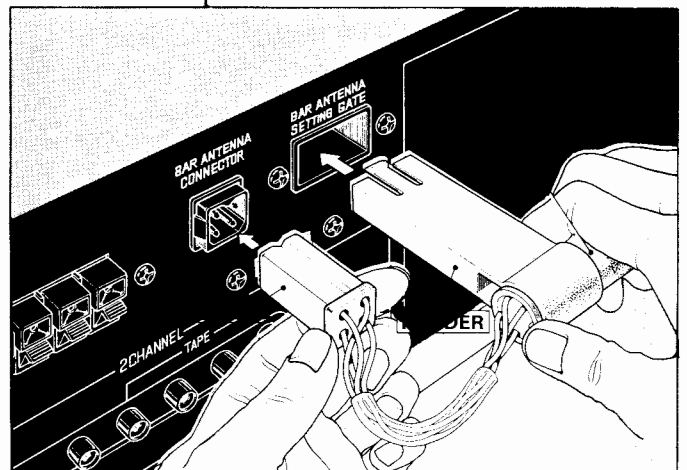

2-CHANNEL TAPE DECKS

Recording and Playback on 2-Channel Tape Decks

If you couple a 2-channel tape deck to the QRX-4500, you'll be able to record and playback a 2-channel stereo tape. Of course, the playback sound can be converted, if desired, into four channels by the built-in QS REGULAR MATRIX circuit and reproduced out of the four speaker systems. If the tape deck is of a 3-head type (with separate record and play heads), you'll be able to monitor the sound as it is recorded. In addition, if you connect two tape decks to the QRX-4500, you'll be able to record into both of them simultaneously or copy a recorded tape from one to the other.

Connecting 2-Channel Tape Decks

The QRX-4500 is provided with two 2-channel tape monitor circuits; one has pin jack terminals and a DIN connector socket, while the other has pin jack terminals and phone type jacks. If you are connecting only one tape deck, you are absolutely free to use any terminals that are most convenient. But if you are connecting two tape decks, be sure to connect one of them to either terminals of the first tape monitor circuit, and the other to either terminals of the second tape monitor circuit. If a tape deck is connected to the phone type jacks of the second tape monitor circuit, the pin jack terminals are automatically cut off and cease to function.

If Using Pin Jacks

If you are using the pin jack terminals to connect your tape deck, proceed as follows:

1. Connect a pair of shielded cables between the 'TAPE REC 1 (or 2)' pin jack terminals of the QRX-4500 and the recording input terminals of your tape deck.
2. Connect another pair of such cables between the receiver's 'TAPE MON 1 (or 2)' pin jack terminals and the tape deck's playback (or monitor) output terminals. Be sure to keep the left and right channel cables in the correct order at both ends.

If Using the DIN Socket

If your tape deck is equipped only with a DIN connector socket, plug the DIN connector cable extending from it into the 5-pin DIN connector socket (marked TAPE-1 REC/PLAY) on the receiver's rear panel.

If Using Phone Jacks

Should your tape deck be equipped with cables with phone type plugs, connect them to the phone jacks on the receiver's front panel. The tape deck's recording input plug should be inserted into the 'TAPE REC' jack on the left, and its playback output plug into the 'PLAYBACK' jack on the right.

2-Channel Recording & Playback Procedures

To Record into a 2-Channel Tape Deck

1. Set the receiver's Selector Control to the program source you want to record.
2. Start the tape deck in the recording mode.
3. To monitor the sound being recorded, push the '2-CH-1' or '2-CH-2' tape monitor switch on the receiver's front panel, depending on which of the two 2-channel tape monitor circuits is accommodating the tape deck at the moment.

To Reproduce the Recorded Tape

1. If you have connected the tape deck to the first 2-channel tape monitor circuit, push the '2-CH-1' tape monitor switch on the receiver's front panel. If you've connected it to the second circuit, push the '2-CH-2' tape monitor switch.
2. Start the tape deck in the playback mode.
3. Use the various controls and switches on the receiver to obtain the best 4-channel stereo effect.

Recording into Two 2-Channel Tape Decks Simultaneously

1. Set the receiver's Selector Control to the program source you want to record.
2. Start both tape decks in the recording mode.

Recording from One Tape Deck to the Other

1. Push the '2-CH-1' tape monitor switch of the receiver.
2. Start the tape deck connected to the second tape monitor circuit, in the recording mode.
3. Now start the other tape deck (connected to the first tape monitor circuit) in the playback mode.

Note:

1. If the tape deck referred to in step 2. is of a 3-head type, the tape being copied can be monitored simply by pushing the '2-CH-2' tape monitor switch of the receiver.
2. The copying (dubbing) of a recorded tape, as described above, is only possible from a tape deck connected to the first tape monitor circuit to the one connected to the second tape monitor circuit.

==== LEFT CHANNEL
 ——— RIGHT CHANNEL

NOTE:
 When tape deck is connected to phone jacks, the pin jack terminals for tape monitor circuit 2 is automatically disabled.

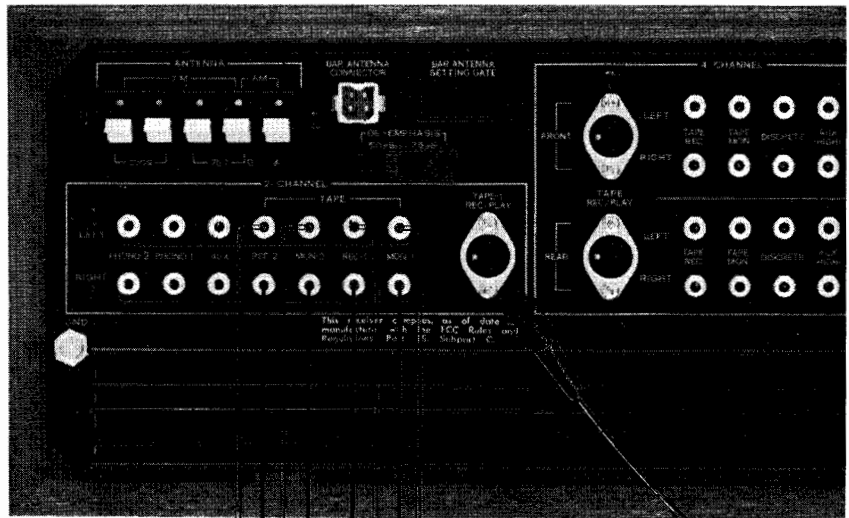
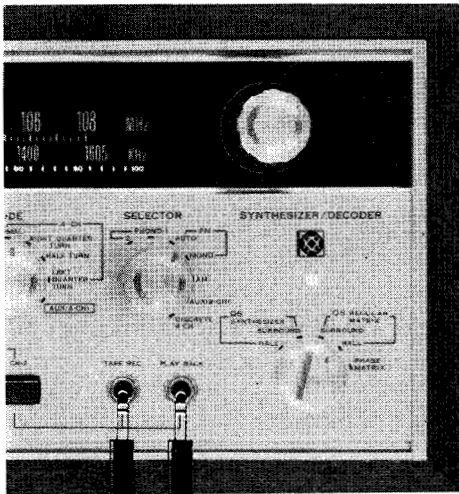

2-CH. PLAYBACK

2-CH. RECORD

2-CH. PLAYBACK

2-CH. RECORD

DIN CABLE

NOTE:
 Do not use
 TAPES REC./MONI
 terminals and
 DIN connector
 socket
 simultaneously.

2-CH.
PLAYBACK

2-CH.
RECORD

2-CH. TAPE DECK 2

2-CH. TAPE DECK 1

4-CHANNEL TAPE DECK

Recording and Playback on a 4-Channel Tape Deck

If you connect a 4-channel tape deck to the QRX-4500, you'll be able to record and reproduce a 4-channel stereo tape. You may either record the 4-channel stereo sound converted from 2-channel program sources by the receiver's built-in QS REGULAR MATRIX circuit, or if you connect two 4-channel tape decks, you'll even be able to record from a discrete 4-channel stereo tape. Of course, if the tape deck is of a 3-head type, it is possible to monitor the sound being recorded.

Connecting a 4-Channel Tape Deck

You may either connect a 4-channel tape deck to the receiver's 4-channel tape monitor pin jacks or DIN connector sockets. If using the former:

1. Connect the tape deck's recording input terminals with the receiver's 4-CHANNEL TAPE REC pin jacks, using shielded cables with pin plugs.
2. Connect the tape deck's playback output terminals with the receiver's 4-CHANNEL TAPE MON pin jacks, using similar cables. In both cases, be sure that the front and rear, left and right channel cables are kept in the correct order at both ends.

On many tape decks, each of the four channels is designated as follows:

- Front left.....Channel 1 or Track 1
- Front rightChannel 3 or Track 3
- Rear leftChannel 2 or Track 2
- Rear rightChannel 4 or Track 4

A 4-channel tape deck can also be connected to the receiver's DIN connector sockets. The QRX-4500 is provided with two such sockets on the rear panel... the upper one for the front channels and the lower one for the rear channels. To connect, you only need plug the DIN connector cables of the tape deck into the appropriate sockets firmly, taking care not to confuse the front and rear channels.

Note: Beside the 4-CHANNEL TAPE REC and MON jacks, your QRX-4500 offers two sets of 4-CHANNEL AUX input jacks and a set of 4-CHANNEL DISCRETE input jacks.

You may connect a 4-channel disc demodulator, 4-channel FM demodulator, 8-track 4-channel cartridge tape player, or even a second 4-channel reel-

to-reel tape deck. If you wish to copy a pre-recorded 4-channel tape from one 4-channel tape deck to another, be sure to connect the second deck (the one used for playback) to the 4-CHANNEL DISCRETE jacks. A program source connected to 4-CHANNEL AUX jacks cannot be recorded into a tape deck connected to the 4-CHANNEL TAPE REC jacks.

4-Channel Recording Procedure

To record the 4-channel sound converted from 2-channel program sources by the receiver's built-in QS REGULAR MATRIX circuit, follow the simple steps described below.

1. Set the receiver's Selector Control to the program source you wish to record. However, if the program source is a 2-channel stereo tape, operate both the 2-channel tape deck and the receiver to reproduce the tape, in accordance with the instructions on '2-Channel Recording & Playback Procedures' on page 13.
2. Turn the receiver's Synthesizer/Decoder Function Control to a position that gives you the sound effect best suited to the type of music you are about to record.
3. Start the 4-channel tape deck in the recording mode.

Note: Push the '4-CH' tape monitor switch on the receiver's front panel if you want to monitor the recording as you make it.

Copying a Recorded 4-Channel Tape

If you want to copy a 4-channel stereo tape, you need another 4-channel tape deck. This second tape deck should be connected to the receiver's DISCRETE input jacks, using shielded cables with pin plugs.

Then:

1. Set the receiver's Selector Control to DISCRETE 4-CH.
2. Start the first 4-channel tape deck (connected to the 4-channel tape monitor terminals) in the recording mode.
3. Start the other 4-channel tape deck (connected to the 4-CHANNEL DISCRETE input jacks) in the playback mode to reproduce the 4-channel stereo tape.

SIMPLE MAINTENANCE HINTS

Place of Installation

The wooden cabinet of the QRX-4500 is designed so that any heat radiated inside will effectively escape through it. Proper care should therefore be taken of the dissipation of such heat if you wish to place something on top of the receiver or place it inside a closed box, etc. Above all, avoid placing it where it may be exposed to the direct sunlight.

Rear-panel AC Outlets

Of the three AC outlets provided on the rear panel, the one marked 'SWITCHED' is controlled by the front-panel Power Switch. The other two, marked 'UNSWITCHED,' are always 'live' and independent of the Power Switch. The three outlets together have limited power capacities, and it is extremely dangerous to connect equipment with bigger power requirements. Before connecting any equipment, make certain its power requirement does not exceed the power capacity limit.

Caution:

The voltage supplied by the AC outlets is the same as the power supply voltage used.

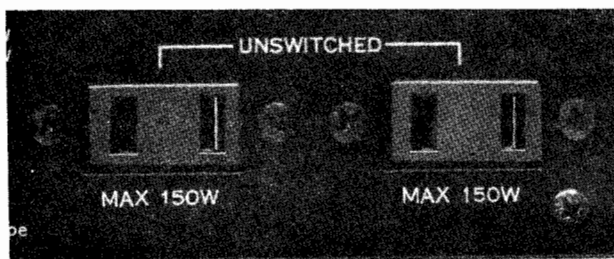
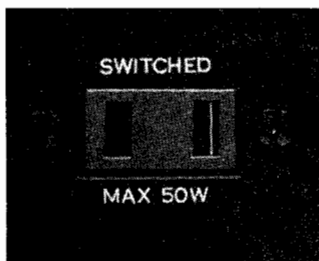

Grounding

Any noise picked up by the connecting cables can be effectively grounded by connecting a piece of PVC (polyvinyl chloride) or enameled wire to the 'GND' terminal on the QRX-4500's rear panel, attaching a small copper plate or carbon rod to the other end and burying it deep underground. The grounding leads of other equipment in your 4-channel stereo system may be connected to the same terminal to ground the entire system at once.

If you have connected an external AM antenna to the receiver, it is advisable to ground it at the same time.

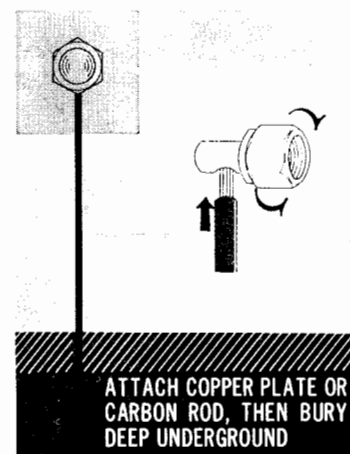

When Connecting a Turntable, etc.

To connect a turntable, tape deck and so forth, it is strongly recommended to use thick, shielded cables with a minimum of distributed capacity and to keep them as short as possible.

To solder the pin plugs supplied as accessories onto such shielded cords, refer to the illustration below.

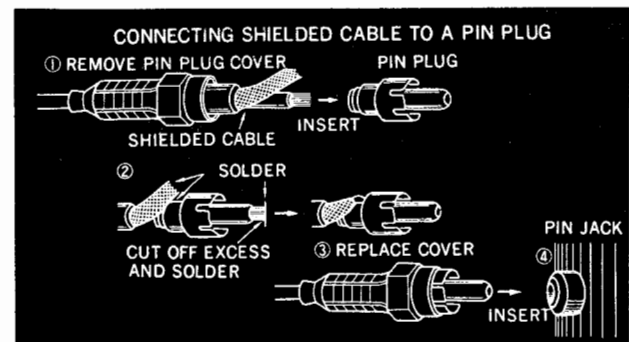

Hum and Howling

Care must be taken never to place a turntable on or too close to a speaker system, or the vibration of the speaker system is transmitted and causes howling. It is best to keep these components completely separated, but if this is impossible, place a thick cushion between them.

Humming is a phenomenon often caused by incomplete or incorrect turntable-receiver connections. If this should occur, check to see if all connections are completely made and if the connecting wires are sufficiently thick. Be sure to connect the grounding lead (or terminal) of the turntable to the GND terminal of the QRX-4500. It may suppress the hum noise which may otherwise occur.

De-emphasis Switch

Different de-emphasis circuits are required to receive FM broadcast in different areas. For example, a $50\mu\text{sec}$. de-emphasis circuit is needed in south Africa, Europe and Japan, but a $75\mu\text{sec}$. one is appropriate in other areas. The De-emphasis Switch on the rear panel of the QRX-4500 is adjusted to the requirements of your area in our factory. If you move to an area where a different FM de-emphasis circuit is necessary (which could be easily found out by asking an FM station or governmental radio office), slide the switch over to the other position.

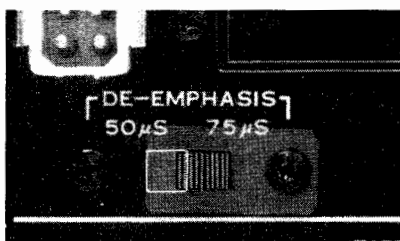

Should the Power Fuse Blow

If no Selector Indicator should glow and the receiver simply remains dead even after you have turned on its Power Switch, it is possible that its power fuse has blown. If this happens, disconnect the power cord from the wall AC outlet at once and examine the power fuse on the receiver's rear panel. If you find it blown, replace it with a new glass-tubed fuse of the rated capacity (5-ampere for 100 to 127 volts, 3-ampere for 220 to 250 volts). Never use a fuse of a different capacity or a piece of wire, even as a stop-gap measure, or serious danger could result.

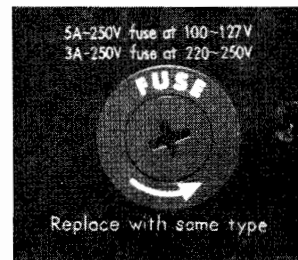

Quick-Acting Fuses

When a Selector Indicator is glowing, if no sound comes out of one or more of the four speaker systems, examine their connections and operation once. If nothing is wrong with them, it is possible that the quick-acting fuse or fuses protecting the power transistors have blown.

If this should happen, disconnect the power cord from the wall AC outlet immediately and check the four quick-acting fuses on the rear panel. If you find any of them blown, discover and eliminate the cause of the blowout, and replace it with a new 2.5-ampere quick-acting fuse supplied. Probable causes of the blowout include excessively large input signals and a short-circuit at the speaker terminals.

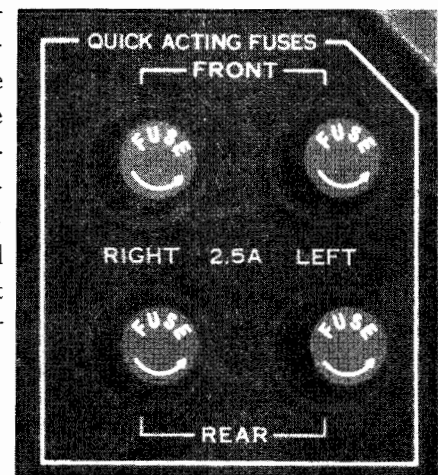

SIMPLE MAINTENANCE HINTS/ACCESSORIES

Voltage Adjustment

So that you may operate your QRX-4500 in any part of the world, it is equipped with Voltage Selector Plugs. As they are set to the correct power supply voltage of your area in our factory prior to shipment, so there is no need to touch them. However, should you move after purchasing the receiver and find the power supply voltage is different, simply reset the plugs as follows:

1. The Voltage Selector Plugs are located at the bottom of the receiver, protected by a metal cover. Remove this cover first by loosening the two screws securing it to the bottom.
2. The metal cover is shaped so as to facilitate extracting the plugs. Pull out the plugs, as illustrated at right.
3. Set the arrow mark on the Main Voltage Selector Plug to the required voltage: 100, 110, 117, 127, 220, 230, 240 or 250 volts.
4. If the required voltage is indicated in red, set the arrow mark on the adjacent Sub Voltage Selector Plug to "RED." If it is indicated in white, however, set that arrow to "WHITE."
5. It may be necessary to change the power fuse itself when the power supply voltage has changed. For 100-127 volt operation, a 5-ampere fuse is required. For 220-250 volt operation, however, it should be changed to a 3-ampere one.
6. Where the power supply voltage considerably fluctuates, the Voltage Selector Plugs may be reset to avoid unpleasant side-effects of such fluctuation. Reset them to the voltage immediately higher than the peak of the fluctuation.

Accessories

- | | |
|--|---|
| 1. FM antenna | 1 |
| 2. AM antenna | 1 |
| 3. Power cord..... | 1 |
| 4. Pin plugs..... | 4 |
| 5. Connecting cord with 3 pin plugs | 1 |
| 6. Polishing cloth | 1 |
| 7. Quick-acting fuses (2.5A) | 2 |
| 8. Butterfly bolts | 2 |
| 9. Washers | 2 |
| 10. Operating Instructions
and Service Manual | 1 |
| 11. Operating Instructions Sheet | 1 |

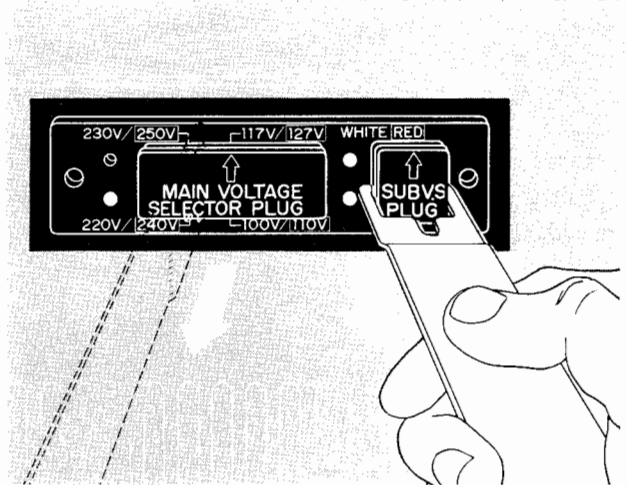
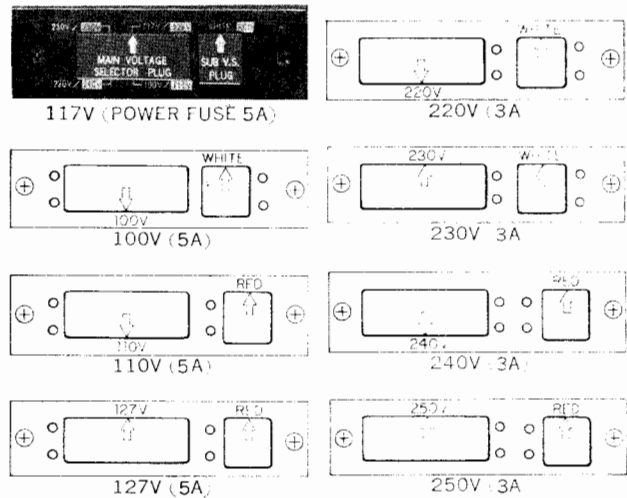

About Servicing

If anything should ever go wrong with your QRX-4500, or if you have any question about it, please contact the Sansui dealer from whom you purchased it or your nearest Authorized Sansui Service Station.

SPECIFICATIONS

AUDIO SECTION

POWER OUTPUT:

MUSIC POWER (IHF): 240 Watts at 4 ohms load
160 Watts at 8 ohms load

CONTINUOUS OUTPUT POWER:

(1kHz, each channel driven)
38 Watts × 4 at 4 ohms load
27 Watts × 4 at 8 ohms load

(1kHz, 4-channel driven):

23+23+23+23 Watts at
8 ohms load

POWER BANDWIDTH (IHF):

20 to 30,000Hz

TOTAL HARMONIC DISTORTION:

less than 0.5% at rated output

INTERMODULATION DISTORTION:

less than 0.5% at rated output
(70Hz: 7,000Hz=4:1 SMPTE
method)

LOAD IMPEDANCE:

4 to 16 ohms

DAMPING FACTOR:

more than 30 at 8 ohms load

INPUT SENSITIVITY:

(1kHz, far rated output)

PHONO 1, 2: 2.5mV (50k ohms)

AUX (2-CH): 150mV (50k ohms)

AUX (4-CH) Low Level: 150mV (50k ohms)

High Level: 450mV (50k ohms)

DISCRETE 4-CH: 150mV (50k ohms)

TAPE MON (2-CH) Pin, DIN:

150mV (50k ohms)

(4-CH) Pin, DIN:

150mV (50k ohms)

RECORDING OUTPUT:

Pin Jack (2-CH) (4-CH): 150mV

DIN Connector (2-CH) (4-CH): 30mV

FREQUENCY RESPONSE (AUX 2-CH):

30 to 30,000Hz ±1.5dB

EQUALIZATION:

RIAA Curve (30 to 15,000Hz
±1.5dB)

CHANNEL SEPARATION (at rated output 1,000Hz):

better than 45dB

HUM AND NOISE (IHF):

PHONO: better than 60dB

AUX (2-CH): better than 70dB

AUX (4-CH): better than 70dB

TONE CONTROLS (FRONT):

BASS: +15dB, -15dB at 50Hz

TREBLE: +15dB, -15dB at 20,000Hz

LOUDNESS CONTROLS (FRONT and REAR):

+8dB at 50Hz,

+3dB at 10,000Hz

FILTERS (FRONT):

Curve: 6dB/oct

LOW: -10dB at 50Hz

HIGH: -10dB at 10,000Hz

SYNTHESIZER/DECODER: SANSUI NEW QS CIRCUIT

(VARIO-MATRIX)

FM SECTION

TUNING RANGE: 88 to 108 MHz

SENSITIVITY (IHF): 2μV

TOTAL HARMONIC DISTORTION:

less than 0.8% (STEREO)

0.5% (MONO)

SIGNAL TO NOISE RATIO: better than 65dB

SELECTIVITY: better than 50dB

CAPTURE RATIO (IHF): 1.5dB

IMAGE FREQUENCY REJECTION:

better than 80dB

IF REJECTION: better than 80dB

SPURIOUS RESPONSE REJECTION:

better than 90dB

SPURIOUS RADIATION: less than 34dB

STEREO SEPARATION: better than 35dB

ANTENNA INPUT IMPEDANCE:

300 ohms balanced,

75 ohms unbalanced

AM SECTION

TUNING RANGE: 535 to 1,605kHz

SENSITIVITY:

FERRITE BAR ANTENNA:

50dB/m

IMAGE FREQUENCY REJECTION:

better than 100dB at 1,000kHz

IF REJECTION:

better than 100dB at 1,000kHz

SELECTIVITY:

better than 30dB

POWER REQUIREMENTS:

POWER VOLTAGE: 100, 110, 117, 127, 220, 230,
240, 250V

POWER CONSUMPTION:

125W (rated), 310VA (max.)

DIMENSIONS:

526mm (20³/₄"W),

171mm (6³/₄"H),

317mm (12¹/₂"D)

WEIGHT:

18.6kg (41 lbs.)

GENERAL TROUBLESHOOTING CHART

If the receiver is otherwise operating satisfactorily, the more common causes of trouble may generally be attributed to the following:

1. Incorrect connections or loose terminal contacts. Check the speakers, turntable, tape deck, antenna and power cord.
2. Improper operation. Before operating any audio com-

ponent, be sure to read its manufacture's instructions.

3. Improper location of audio components. The proper positioning of components, such as speakers and turntable, is essential to the maximum stereo enjoyment.

4. Defective audio components.

The following are some other common causes of malfunction and what to do about them.

PROGRAM	SYMPTOM	PROBABLE CAUSE	WHAT TO DO
AM, FM or MPX reception.	A. Constant or intermittent noise heard at times or in certain areas.	<ul style="list-style-type: none"> * Discharge or oscillation caused by electrical appliances, such as fluorescent lamp, TV set, D.C. motor rectifier or oscillator. * Natural phenomena, such as atmospheric, static or thunderbolts. * Insufficient antenna input due to ferroconcrete wall or long distance from station. 	<ul style="list-style-type: none"> * Attach noise limiter to electrical appliance producing noise, or attach it to receiver's power source. * Install outdoor antenna and ground receiver to raise SN ratio. * Reverse power cord plug/receptacle connections. * If noise occurs at certain frequency, attach wave trap to input. * Keep receiver at proper distance from other electrical appliances.
AM reception.	A. Noise heard at particular time of a day, in certain area or over part of dial.	<ul style="list-style-type: none"> * Peculiar to AM broadcasts. 	<ul style="list-style-type: none"> * Install antenna for maximum antenna efficiency. See "RADIO RECEPTION" in operating instructions booklet. * In some cases, noise can be eliminated by grounding receiver or reversing power cord plug/receptacle connections.
	B. High-frequency noise.	<ul style="list-style-type: none"> * Adjacent-channel interference or beat interference. * TV set too close to audio system. 	<ul style="list-style-type: none"> * Such noise cannot be completely eliminated by the receiver, but it is advisable to turn Treble control counterclockwise turn on High Filter. * Keep TV set at proper distance from stereo system.
FM reception.	A. Noisy.	<ul style="list-style-type: none"> * Poor noise limiter effect or too low SN ratio due to insufficient antenna input. <p>Note: FM reception is affected considerably by transmission conditions of station, such as power and antenna efficiency. As a result, you may receive one station quite well while receiving another station poorly.</p>	<ul style="list-style-type: none"> * Install antenna (supplied) for maximum signal strength. * If this does not prove effective, use exclusive FM outdoor antenna. If using TV antenna for both TV and FM with divider, make sure TV reception is not affected. * Exclusively long lead-in wire of antenna may cause noise.
	B. A series of pops.	<ul style="list-style-type: none"> * Ignition noise caused by starting of nearby automobile engine. 	<ul style="list-style-type: none"> * Install antenna and its lead-in wire at proper distance from street or increase antenna input as described before.
	C. Tuning noise between stations.	<ul style="list-style-type: none"> * Results from nature of FM reception. * FM Muting Release switch depressed. 	<ul style="list-style-type: none"> * Release FM Muting Release switch. * Same as above.

PROGRAM	SYMPTOM	PROBABLE CAUSE	WHAT TO DO
FM-MPX reception.	A. Noise heard during FM-MPX reception but inaudible during FM mono reception.	* Weaker signal because service area of FM-MPX broadcast is only half that of FM mono broadcast.	* Orient antenna for maximum antenna input. * Switch on High Filter and/or turn Treble control counterclockwise.
	B. Channel separation deteriorates during reception.	* Excess heat.	* Circulation of room air is important to receiver. Be sure that receiver is well ventilated.
	C. Stereo indicator blinks on and off.	* Interference.	* Indicator is not faulty, adjust VR ₄₀₃ .
Record playing or tape playback.	A. Hum or howling.	* Turntable placed directly on speaker. * Wire other than shielded cable used. * Loose terminal contact. * Shielded cable too close to power cord, fluorescent lamp or other appliances. * Nearby amateur radio station or TV transmission antenna.	* Place cushion between turntable and speaker cabinet or place them away from each other. * Connecting shielded cables should be as short as possible. * Turn on Low Filter and turn Bass control counterclockwise. * Consult nearest Radio Regulatory Bureau.
	B. Surface noise.	* Worn or old record. * Worn phono stylus. * Phono stylus is dusty. * Improper stylus pressure.	* Recondition playback head of tape deck or the stylus of turntable. * Turn Treble control counterclockwise. * Turn High Filter on.
4-channel stereo playback.	A. Position of musical instruments and voice not clear.	* Incorrect phasing of speakers or input connections.	* Check phasing of speakers and input connections. * Change rear speaker position and/or direction.

DISASSEMBLY PROCEDURE

REMOVING WOOD CASE, FRONT PANEL AND BOTTOM BOARD

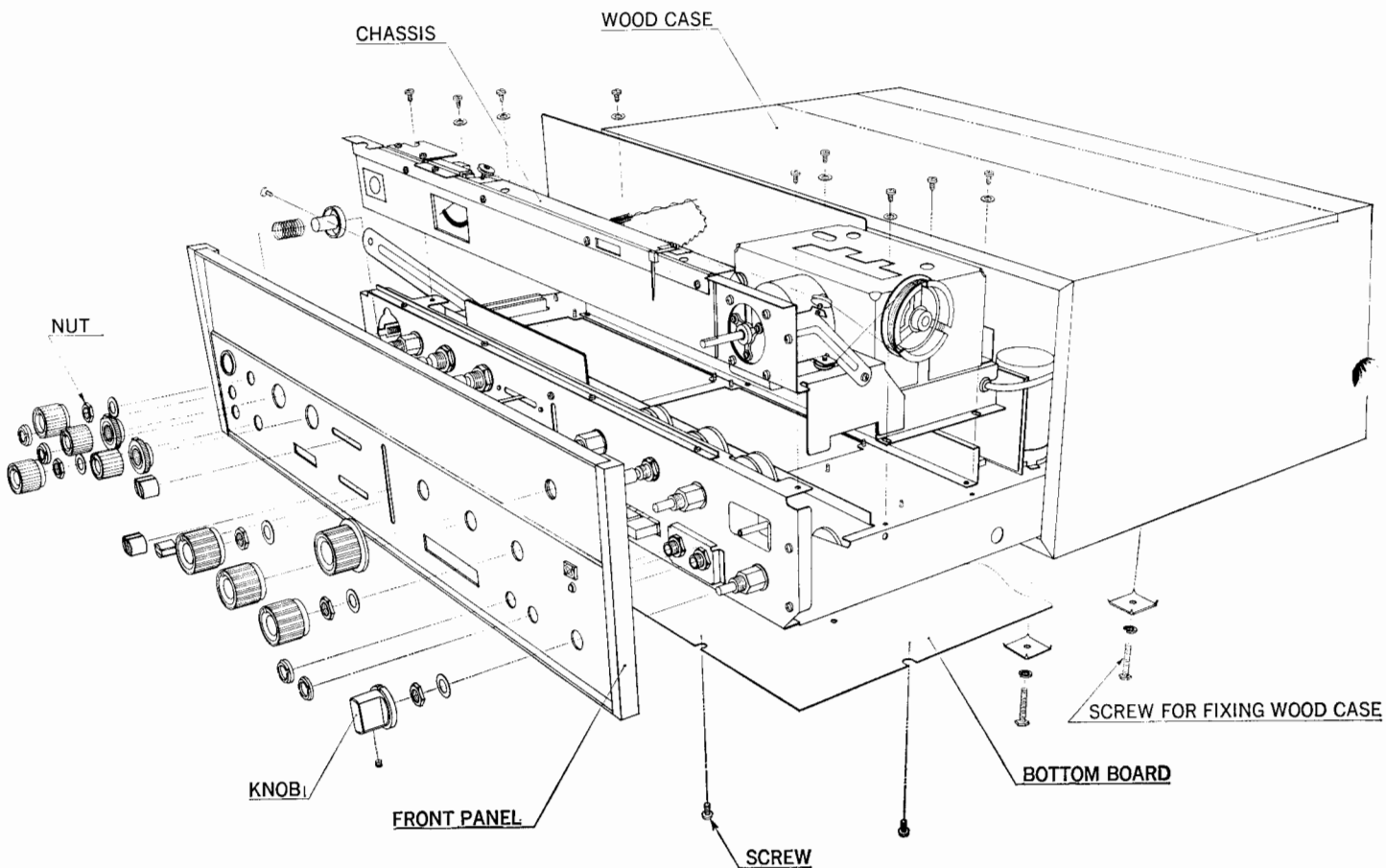

DIAL MECHANISM

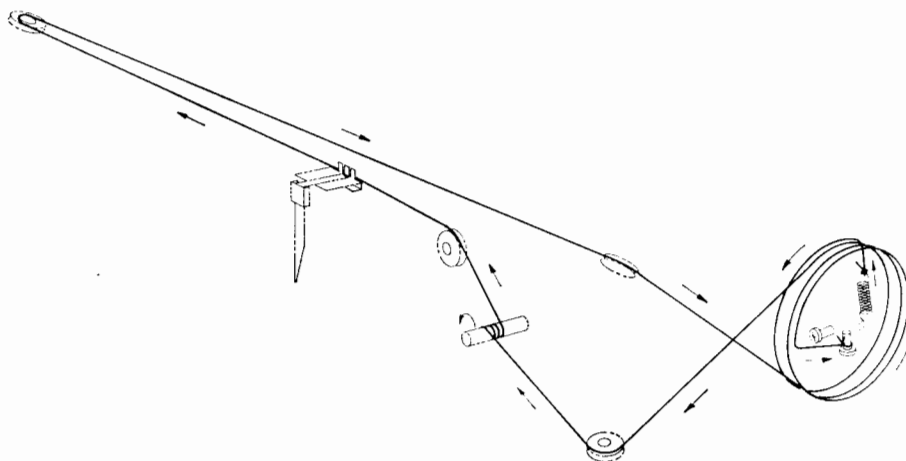

The Tuner Block, if necessary, can be independently separated from the rest of the receiver for examination and servicing purposes. To do so, follow these simple steps:

1. Remove the eleven screws fastening the Tuner Block to the receiver proper.
2. Free the Tuning Control and pull it out. The Tuner Block now floats freely off the receiver proper, but if you need disconnect it completely, move on to steps 3~5.

3. Unplug the multi-connector (see photo below) very carefully.

4. Pull off the lead wires of the AM ferrite bar antenna. (When you re-assemble, connect the grey wire to F-1038-5 (3A), the black one to F-1038-5 (3B), and the white one to VC₀₀₁).

5. Disconnect, in the middle, the coaxial cable connecting the FM 75Ω terminals to the FM Frontend.

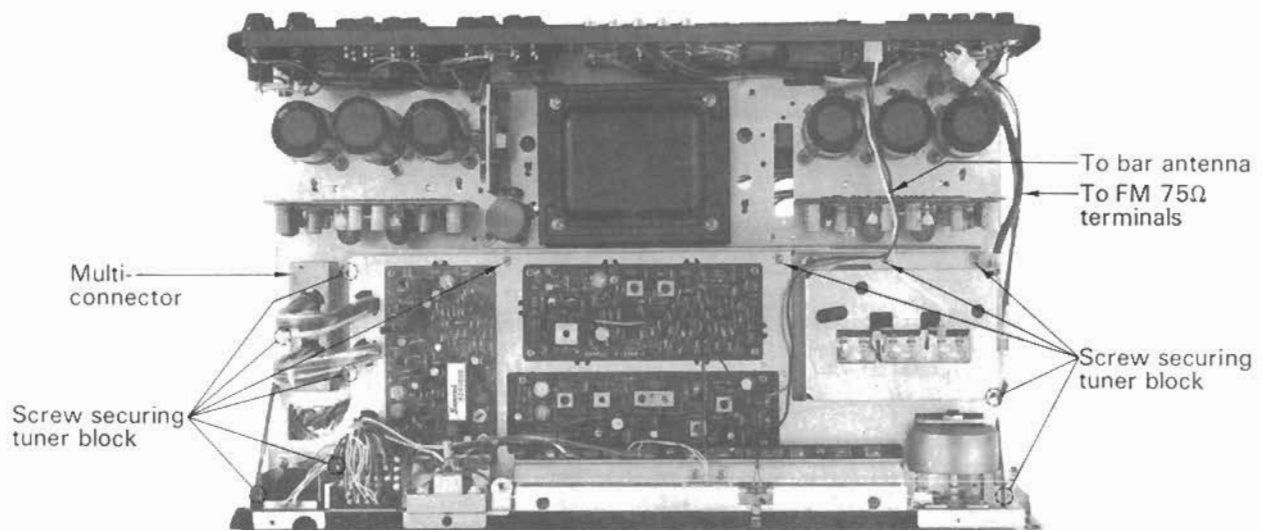

CAUTION

When re-inserting the multi-connector to align the Tuner Block already dismantled or to re-assemble the block itself, be very careful to insert it in exactly the same way as before.

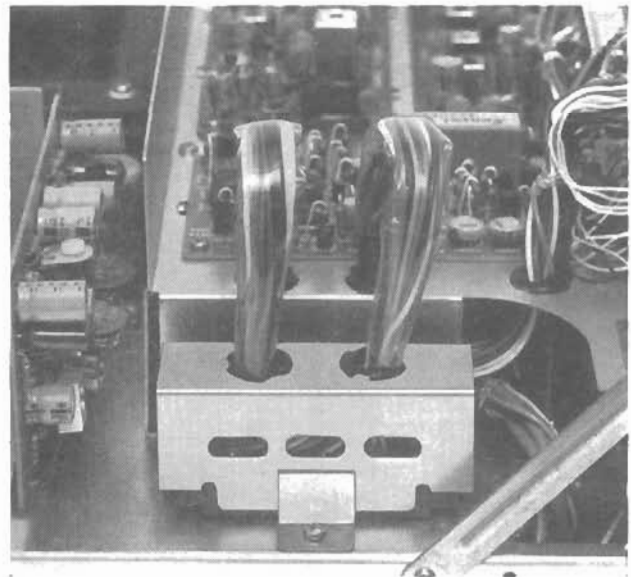

TEST POINTS

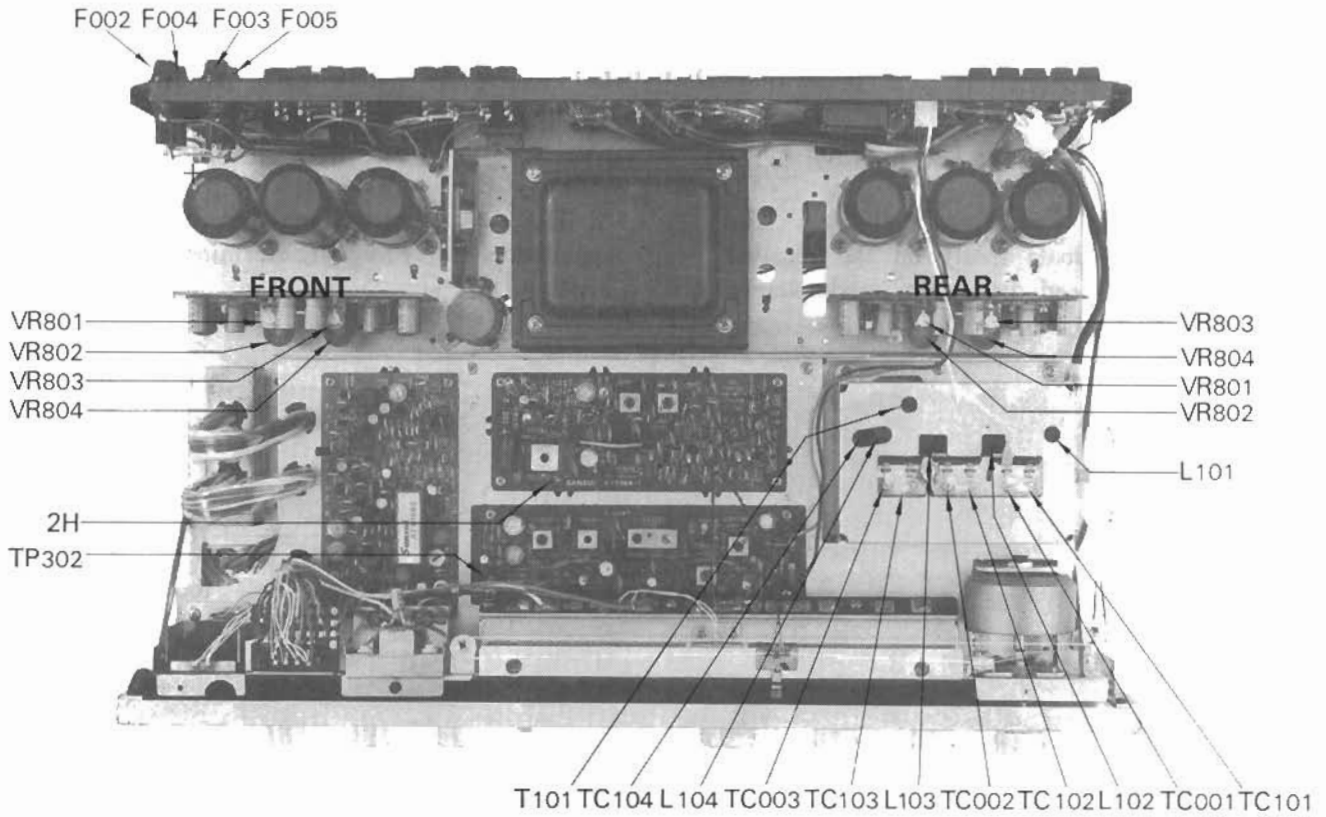

BOTTOM VIEW OF FM FRONTEND

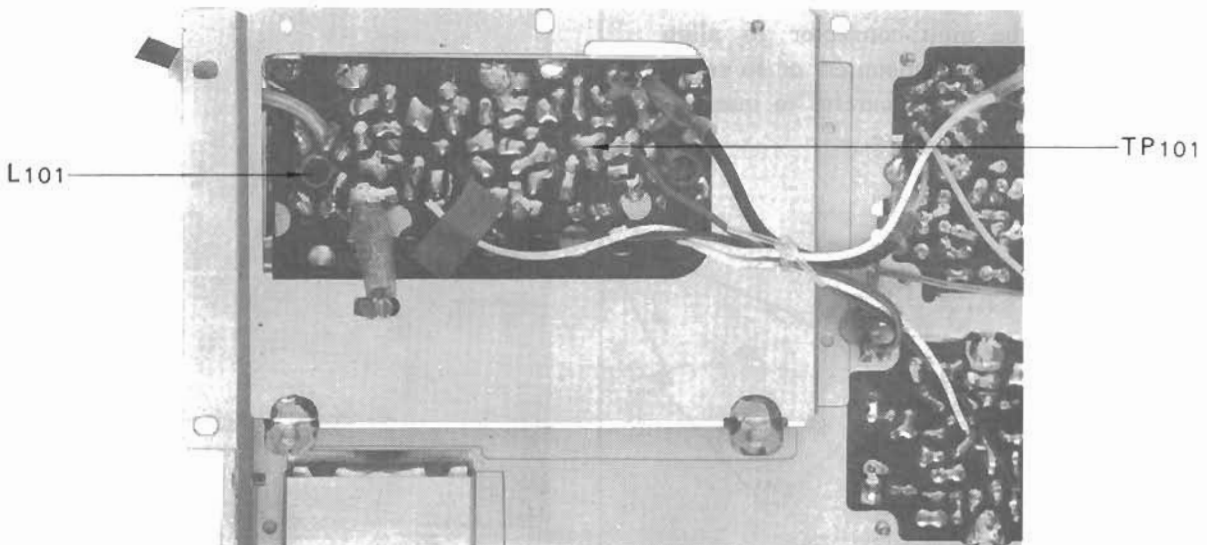

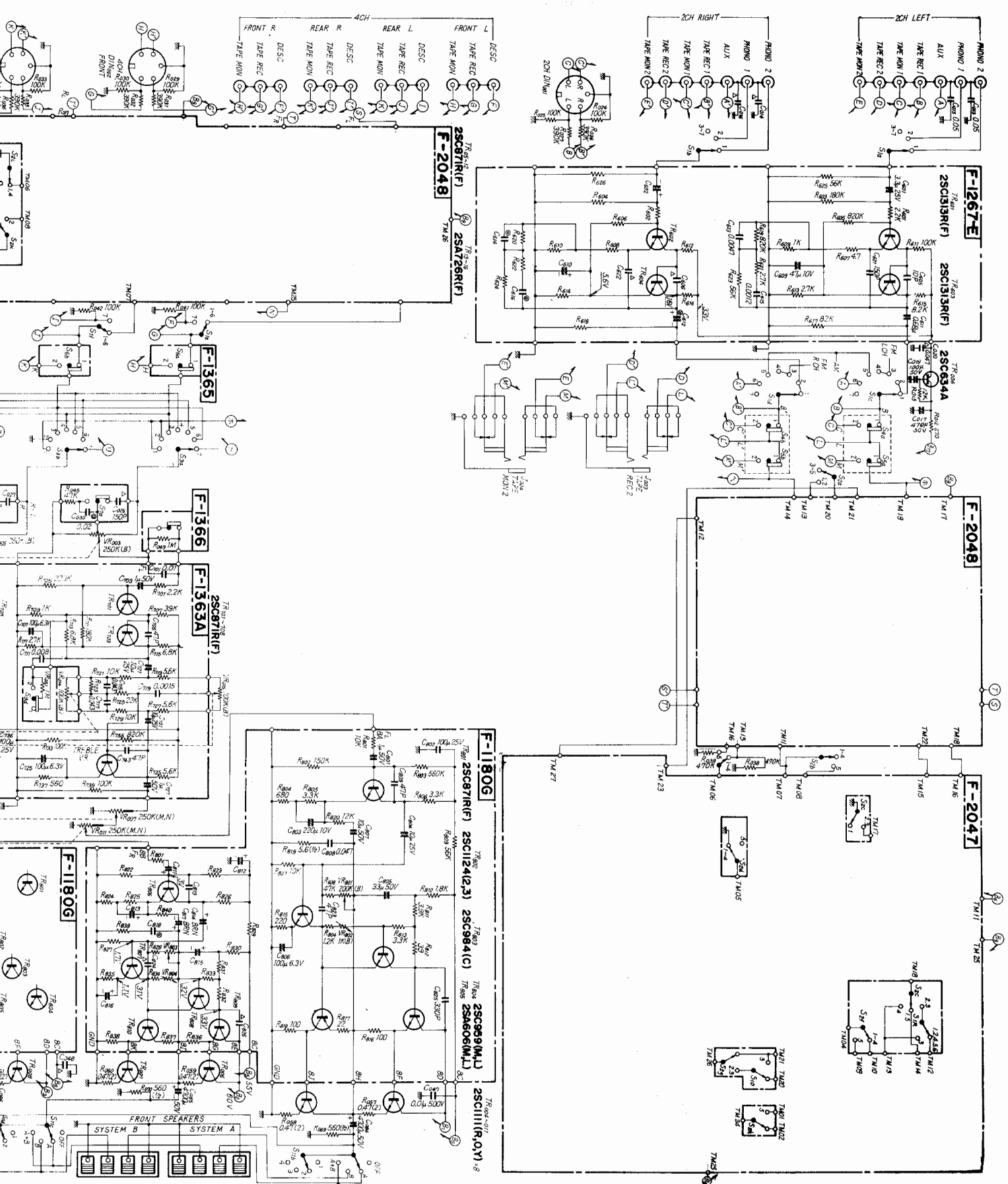

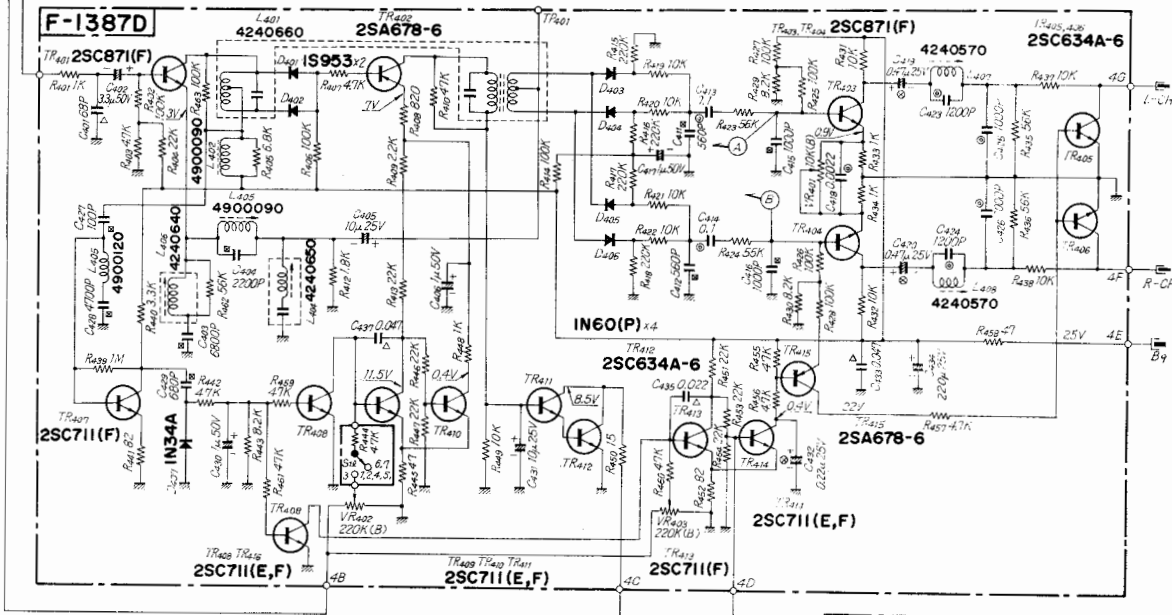
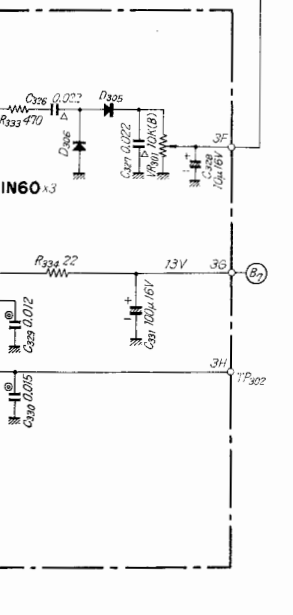
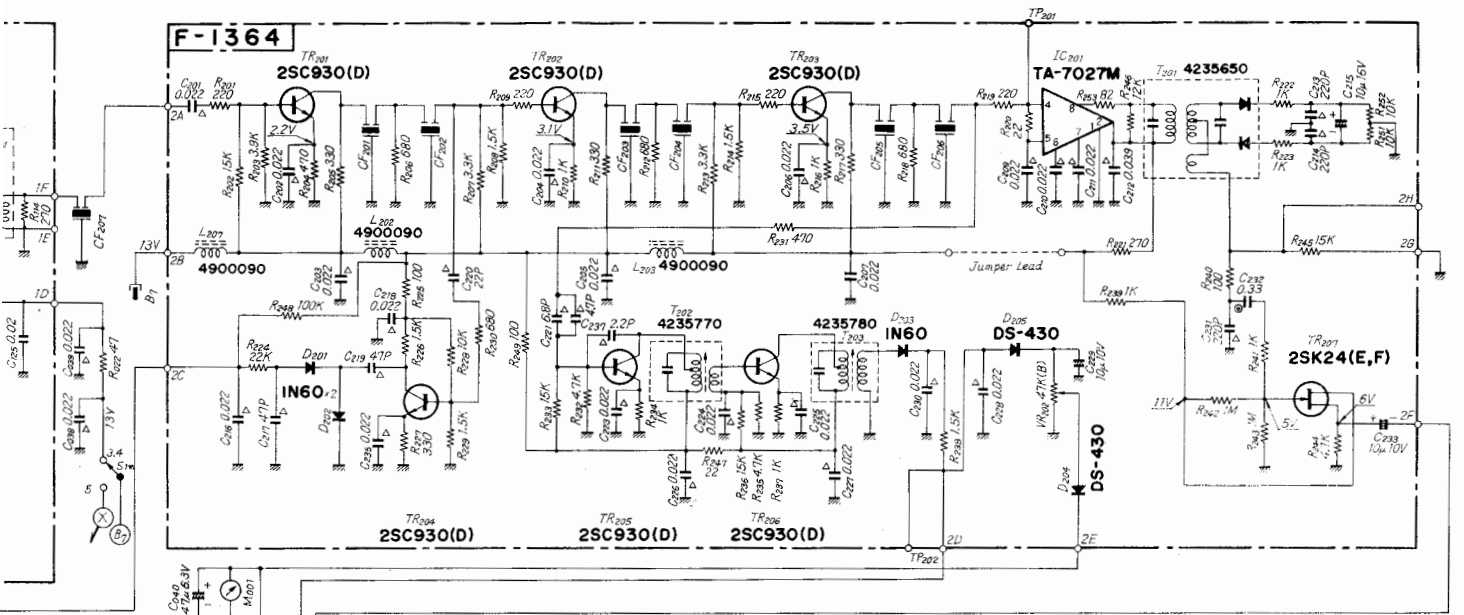

SWITCHES

SELECTOR S₁ (a-p)

1. PHONO 2
2. PHONO 1
3. FM AUTO
4. FM MONO
5. AM
6. AUX (2CH)
7. DISCRETE 4-CH

SYNTHESIZER

DECODER S₂ (a-f)

1. Q.S SYNTHESIZER HALL
2. Q.S SYNTHESIZER SURROUND
3. Q.S REGULAR MATRIX SURROUND
4. Q.S REGULAR MATRIX HALL
5. PHASE MATRIX

MODE S₃ (a-r)

1. FRONT & REAR
2. FRONT ONLY
3. NORMAL
4. RIGHT QUARTER TURN
5. HALF TURN
6. LEFT QUARTER TURN
7. 4-CH AUX

TAPE MONITOR

- 2CH-1 S₄ (a-b)
1. OFF 2. ON
2CH-2 S₅ (a-b)
1. OFF 2. ON
4CH S₆ (a-a)
1. OFF 2. ON

LOUDNESS S₇ (a-b)

1. OFF 2. ON

MUTING S₈

1. ON 2. OFF

HIGH FILTER S₉ (a-b)

1. OFF 2. ON

LOW FILTER S₁₀ (a-b)

1. OFF 2. ON

FRONT SPEAKERS S₁₁

1. OFF
2. A
3. B

REAR SPEAKERS S₁₂

1. OFF
2. A
3. B
4. A+B

POWER S₁₃

1. OFF
2. ON

DE-ENPHASIS S₁₄ (a-b)

△ CERAMIC

○ OIL

○ MYLAR

□ MICA

■ STYROL

⊗ TANTALUM

ALIGNMENT

CURRENT ADJUSTMENT

STEP	SETTING OF AMMETER (TESTER)	WHAT TO DO	NOTE
1.		Remove F_{002} and F_{003} .	Use an ammeter with 100mA range.
2.		Set VR_{802} and VR_{804} to minimum.	
3.		Set Volume Control to minimum.	
4.		Turn on receiver.	Be sure to switch on 1st and the connect the ammeter.
5.	100mA range.	Connect ammeter to F_{002} .	
6.		Turn VR_{802} clockwise and adjust current to 30 to 25 mA.	
7.	100mA range.	Turn receiver off and replace F_{002} .	
8.		Turn receiver on and connect ammeter to F_{003} as illustrated in Fig. 1.	
9.		Turn VR_{804} clockwise and adjust current to 30 to 25 mA.	
10.		Replace F_{003} .	
11.		Adjust rear channels as above.	

OUTPUT ADJUSTMENT

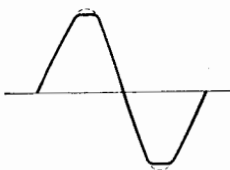
STEP	WHAT TO DO	NOTE
1.	Adjust Volume Control to minimum.	
2.	Set oscillator to 1,000Hz and connect it to 4-CHANNEL DISCRETE FRONT LEFT.	Oscillator should have oscillation frequency of 20 to 20,000Hz and output voltage of more than 200mV.
3.	Set Selector Control to DISCRETE 4-CH.	Set other controls and switches as follows.
4.	Set Front Speakers Switch to A.	Balance to CENTER Tape Monitor to OFF Mode to NORMAL Tone to CENTER Others to OFF.
5.	Connect 8- or 16-ohm load resistor with capacity of more than 30 watts to SPEAKER SYSTEM-A FRONT LEFT output.	
6.	Connect oscilloscope across load resistor connected above.	
7.	Turn receiver on and slowly raise volume. Check output by means of oscilloscope.	
8.	Adjust VR_{801} (left channel) so that peak of sine wave is clipped simultaneously.	
9.	Adjust right channel similarly, and then rear channels.	

ALIGNMENT

FM ALIGNMENT PROCEDURE

NOTE: Set the FM signal generator level to minimum first.

Any internal parts replacement or change you make in the QRX-4500 requires proper adjustment again. Test points, adjustment procedures and schematic diagrams are given on pages 25~32.

Equipment required: 1. Sweep Generator 2. Oscilloscope 3. FM Signal Generator 4. Multiplex Stereo Generator 5. AC V.T.V.M.

STEP	ALIGN	GENERATOR	FEED SIGNAL	OUTPUT INDICATOR	DIAL SETTING	ADJUST	ADJUST FOR
1.	Discriminator	10.7MHz ±200kHz sweep generator	To TP ₁₀₁ via 10pF ceramic capacitor	Oscilloscope connected to 2H		FM discriminator transformer T ₂₀₁ primary and secondary	S curve
2.	OSC	FM signal generator 88MHz 400Hz 100% modulation	To antenna terminals	Oscilloscope and V.T.V.M. at output load	88MHz	OSC coil L ₁₀₄	Maximum
3.	OSC	FM signal generator 108MHz 400Hz 100% modulation	To antenna terminals	Oscilloscope and V.T.V.M. at output load	108MHz	OSC trimmer cap. TC ₁₀₄	Maximum
4.	Repeat 2 and 3						
5.	RF amp. circuit	FM signal generator 90MHz 400Hz 100% modulation	To antenna terminals	Oscilloscope and V.T.V.M. at output load	90MHz	Antenna coil L ₁₀₁ , L ₁₀₂ and L ₁₀₃	Maximum
6.	RF amp. circuit	FM signal generator 106MHz 400Hz 100% modulation	To antenna terminals	Oscilloscope and V.T.V.M. at output load	106MHz	Trimmer cap. TC ₁₀₁ , TC ₁₀₂ and TC ₁₀₃	Maximum
7.	Repeat 5 and 6						

FM DISCRIMINATOR WAVEFORM

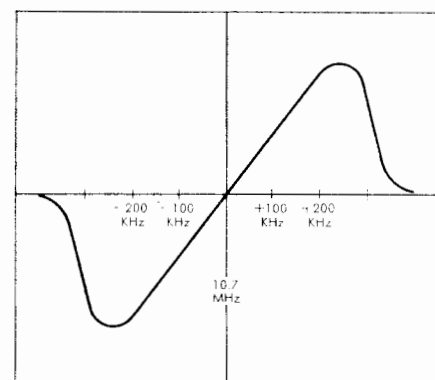

FM MULTIPLEX CIRCUIT

STEP	ALIGN	GENERATOR	FEED SIGNAL	OUTPUT INDICATOR	DIAL SETTING	ADJUST	ADJUST FOR
1.	19kHz phase	FM signal generator— 98MHz Stereo signal generator —composite signal with pilot signal, left chan, 30% modulation.	To antenna terminal	Connect distortion meter to right channel speaker terminal	98MHz	L ₄₀₁	Minimum distortion in right channel.
2.	Stereo separation	Same as above	Same as above	Connect oscilloscope and V.T.V.M. to speaker terminal	Same as above	VR ₄₀₁	Maximum separation

AM ALIGNMENT PROCEDURE

NOTE: To align, set the AM signal generator level to minimum.

STEP	ALIGN	GENERATOR	FEED SIGNAL	OUTPUT INDICATOR	DIAL SETTING	ADJUST	ADJUST FOR
1.	IF transformer	455kHz \pm 30kHz sweep-generator	Antenna terminals	Oscilloscope and V.T.V.M. at TP ₃₀₂		I.F.T. T ₃₀₃ ~T ₃₀₅	Best IF waveform
2.	OSC	AM-generator 535kHz 400Hz 30% modulation	Antenna terminals	Oscilloscope and V.T.V.M. at output load	535kHz	OSC coil T ₃₀₂	Maximum
3.	OSC	AM-generator 1600kHz 400Hz 30% modulation	Antenna terminals	Oscilloscope and V.T.V.M. at output load	1600kHz	OSC trimmer cap. TC ₀₀₃	Maximum
4.	Repeat 2 and 3						
5.	RF amp.	AM-generator 600kHz 400Hz 30% modulation	Antenna terminals	Oscilloscope and V.T.V.M. at output load	600kHz	RF transformer T ₃₀₁	Maximum
6.	Antenna circuit	AM-generator 600kHz 400Hz 30% modulation	Antenna terminals	Oscilloscope and V.T.V.M. at output load	600kHz	Ferrite bar antenna coil L ₀₀₂	Maximum
7.	RF amp.	AM-generator 1400kHz 400Hz 30% modulation	Antenna terminals	Oscilloscope and V.T.V.M. at output load	1400kHz	RF trimmer cap. TC ₀₀₂	Maximum
8.	Antenna circuit	AM-generator 1400kHz 400Hz 30% modulation	Antenna terminals	Oscilloscope and V.T.V.M. at output load	1400kHz	Antenna circuit trimmer cap. TC ₀₀₁	Maximum
9.	Repeat 5, 6, 7, 8						

AM IF WAVEFORM

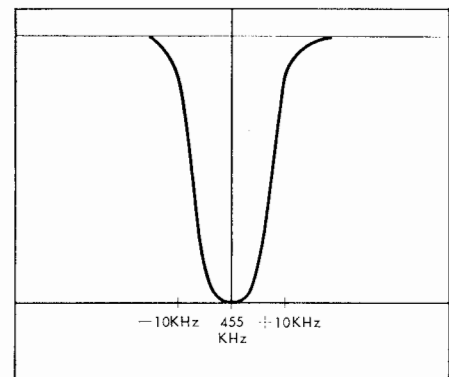

PRINTED CIRCUIT BOARDS AND PARTS LIST

W: Parts No. X: Parts Name Y: Stock No. Z: Position of Parts

AM BLOCK (F-1038-4C)

Stock No. 7530130

W	X	Y	Z
R301	10kΩ	0107103	1, 2 C
R302	39Ω	0107390	1 C
R303	1kΩ	0107102	2 C
R304	100Ω	0107101	1 C
R305	3.9kΩ	0107392	2 C
R306	33kΩ	0107333	1 C
R307	22Ω	0107220	1, 2 B
R308	1kΩ	0107102	2 B
R309	100Ω	0107101	1 C
R310	22kΩ	0107223	2 B, C
R311	3.9kΩ	0107392	1 B
R312	1kΩ	0107102	2 B
R313	10Ω	0107100	2 B, C
R315	47kΩ	0107473	1 A
R316	10kΩ	0107103	2 B
R317	47kΩ	0107473	1 B
R318	100Ω	0107101	1 B
R319	22Ω	0107220	2 B
R320	1kΩ	0107102	2 B
R322	100Ω	0107101	1 B
R323	4.7kΩ	0107472	2 B
R324	100kΩ	0107104	2 A, B
R325	100kΩ	0107104	2 A, B
R326	22kΩ	0107223	2 A
R327	2.2kΩ	0107222	2 B
R328	22Ω	0107220	1 A, B
R329	4.7kΩ	0107472	1 A, B
R330	22kΩ	0107223	1 A
R331	330Ω	0107331	1 A
R332	4.7kΩ	0107472	2 A
R333	470Ω	0107471	1 A
R334	22Ω	0107220	1 A
R335	1kΩ	0107102	2 A
R336	100Ω	0107101	2 A
R337	4.7kΩ	0107472	2 A
R338	3.9kΩ	0107392	2 A
R341	100kΩ	0107104	
VR301	10kΩ (B) AM Meter Adj.	1035130	1, 2 A
C301	0.022μF } +80% 25 V CC.	0656223	1 C
C302	0.039μF } -20%	0656393	2 C
C303	3.3μF	0515339	2 C
C304	0.022μF	0656223	2 C
C305	0.039μF	0656393	1 C
C306	0.039μF } +80% 25 V CC.	0656393	2 C
C307	0.039μF } -22%	0656393	1 C
C308	0.022μF	0656223	1 B
C309	0.01μF	0601107	2 B
C310	0.01μF	0601107	2 B
C311	22pF	0660220	2 C
C312	430pF	0640431	2 C
C313	0.022μF } +80% 25 V CC.	0656223	1 C
C314	4.7μF	0512479	2 B
C315	0.022μF } +80% 25 V CC.	0656223	2 B
C316	0.022μF } -20%	0656223	1 B

W	X	Y	Z
C317	0.039μF } +80% 25 V CC.	0656393	2 B
C318	0.039μF } -20%	0656223	1 B
C319	33μF	0512330	2 B
C320	0.022μF	0601227	2 A
C321	3.3μF	0515339	2 B
C322	0.022μF	0601227	2 A
C323	0.039μF	0656393	2 B
C324	0.039μF	0656393	2 A
C325	0.022μF } +80% 25 V CC.	0656223	1 A
C326	0.022μF } -20%	0656223	1 A
C327	0.022μF	0656223	1 A
C328	10μF	0512100	2 A
C329	0.012μF	0601127	2 A
C330	0.015μF	0601157	2 A
C332	0.022μF	0656223	1 B
C333	0.039μF } +80% 25 V CC.	0656393	2 A
C334	33μF	0512330	1 C
TR301	} 2SC380 (O)	0305331	1 C
TR302		0305331	1 C
TR303		0305331	2 B
TR304	} 2SC380 (R)	0305330	1, 2 B
TR305		0305330	1 A
TR306	2SC458LG (C)	0305311	2 A
D301	1N60	0310330	1, 2 C
D302	} DS-410	0340030	1 C
D30E		0340030	2 B
D304	} 1N60	0310330	1, 2 A
D305		0310330	1 A
D306		0310330	1 A
T301	AM RFT	4210100	1 C
T302	AM OSC Coil	4220300	2 C
T303	Ceramic Filter	4230440	1 B
T304	} AM IFT 455kHz	4230480	1 B
T305		4230470	1 A
	Printed Circuit Board F-1038-5	2530100	

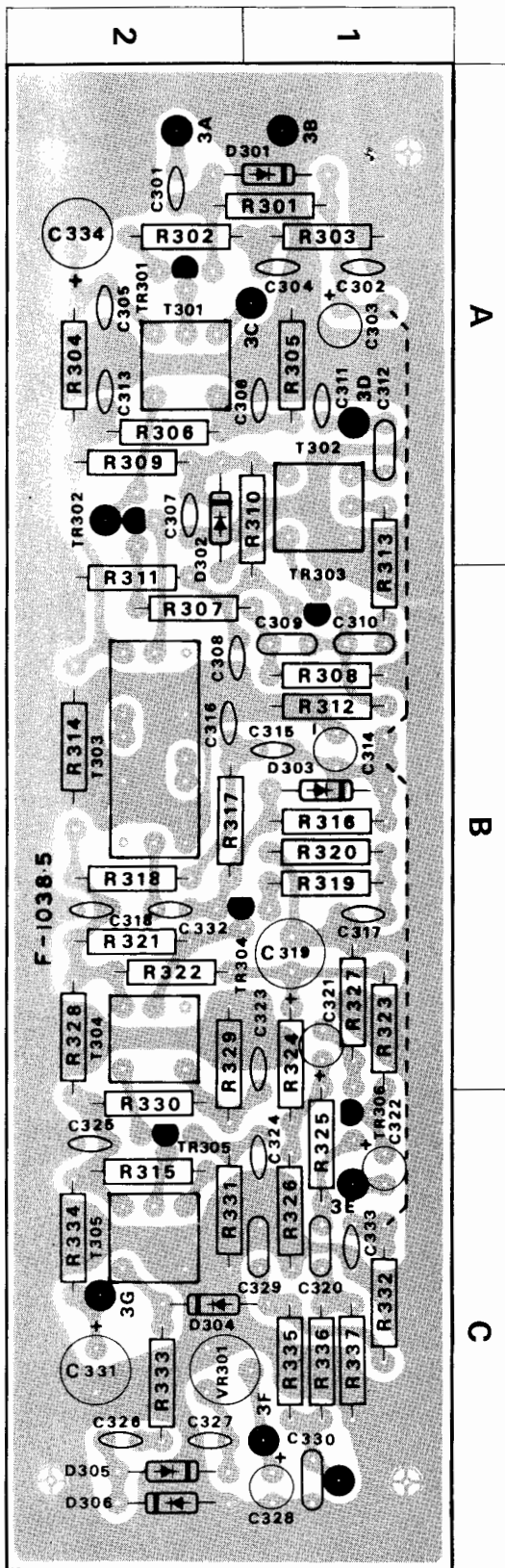

■ Please contact the nearest Sansui Authorized Service Station for replacement parts. When ordering them, look up the part lists on pages 33 to 47 and let us know (1) the receiver model number, (2) name of the printed circuit board, (3) part No., (4) name of the part, and (5) its stock No. Using nonstandard parts for temporary relief often impairs the sound quality and over-all reliability of the receiver. Please take the trouble to contact your nearest Sansui Authorized Service Station.

■ Abbreviations

- CR** : Carbon Resistor
- SR** : Solid Resistor
- CeR** : Cement Resistor
- MC** : Mylar Capacitor
- EC** : Electrolytic Capacitor
- AEC** : Aluminum Solid Electrolytic Capacitor
- CC** : Ceramic Capacitor
- MIC** : Mica Capacitor
- SC** : Styrol Capacitor
- OC** : Oil Capacitor
- MPC** : Metallized Polyester Capacitor
- TC** : Tantalum Capacitor

PRINTED CIRCUIT BOARDS AND PARTS LIST

W: Parts No. X: Parts Name Y: Stock No. Z: Position of Parts

FM IF BLOCK <F-1364-1>

Stock No. 7520380

W	X	Y	Z
R201	220Ω	0106221	2 C
R202	15kΩ	0106153	2 C
R203	3.9kΩ	0106392	2 C
R204	1kΩ	0106102	2 C
R205	330Ω	0107331	2 C
R206	680Ω	0107681	2 C
R207	3.3kΩ	0106332	2 C
R208	1.5kΩ	0106152	2 C
R209	220Ω	0106221	2 C
R210	1kΩ	0106102	2 C
R211	330Ω	0106331	2 C
R212	680Ω	0107681	2 C
R213	3.3kΩ	0106332	2 C
R214	1.5kΩ	0106152	2 C
R215	220Ω	0106221	2 B
R216	1kΩ	0106102	2 B
R217	330Ω	0106331	2 B
R218	680Ω	0107681	2 B
R219	220Ω	0107221	2 B
R220	22Ω	0106220	2 B
R221	270Ω	0107271	2 A
R222	1kΩ	0107102	2 A
R223	1kΩ	0107102	1 A
R224	22kΩ	0106223	1 C
R225	100Ω	0107101	1, 2 C
R226	1.5kΩ	0107152	1 C
R227	330Ω	0106331	1 C
R228	10kΩ	0107103	1 C
R229	1.5kΩ	0106152	1 C
R230	680Ω	0107681	1, 2 C
R231	470Ω	0107471	1, 2 C
R232	4.7kΩ	0106472	1 C
R233	15kΩ	0106153	1 C
R234	1kΩ	0106102	1 B
R235	4.7kΩ	0106472	1 B
R236	15kΩ	0107153	1 B
R237	1kΩ	0106102	1 B
R238	1.5kΩ	0106152	1 B
R239	1kΩ	0107102	1, 2 A
R240	100Ω	0107101	2 A
R241	1kΩ	0107102	1 A
R242	1MΩ	0106105	1 A
R243	1MΩ	0106105	1 A
R244	4.7kΩ	0106472	1 A
R245	15kΩ	0107153	2 A
R246	12kΩ	0107123	2 A
R247	22Ω	0107220	1 B
R248	100kΩ	0107104	1, 2 C
R249	100Ω	0107101	1, 2 B
R250	10kΩ	0106103	1 A
R251	10kΩ	0106103	1 A
R252	82Ω	0106820	2 A
VR202	47kΩ (B)	1035170	1 A, B
C201	0.022μF	0657223	1, 2 C
C202	0.022μF	0657223	2 C

± 5% 1/4 W CR.

W	X	Y	Z
C203	0.022μF	0657223	1 C
C204	0.022μF	0657223	2 C
C205	0.022μF	0657223	1, 2 C
C206	0.022μF	0657223	2 B
C207	0.022μF	0657223	2 B
C209	0.022μF	0657223	2 B
C210	0.022μF	0657223	2 B
C211	0.022μF	0657223	2 B
C212	0.039μF	0657393	2 A
C213	220pF	0660221	2 A
C214	220pF	0660221	2 A
C215	10μF	0511100	1 A
C216	0.022μF	0657223	1 C
C217	47pF	0660470	1 C
C218	0.022μF	0657223	1 C
C219	47pF	0660470	1 C
C220	22pF	0660220	2 C
C221	6.8pF	0669018	1 C
C223	0.022μF	0657223	1 C
C224	0.022μF	0657223	1 B
C225	0.022μF	0657223	1 B
C226	0.022μF	0657223	1 B
C227	0.022μF	0657223	1 B
C228	0.022μF	0657223	1 B
C229	10μF	0511100	1 B
C230	0.022μF	0657223	1 B
C231	220pF	0660221	2 A
C232	0.33μF	0601338	2 A
C233	10μF	0511100	1 A
C235	0.022μF	0657223	1 A
C237	2.2pF	0660229	1 C
TR201		0305791	2 C
TR202		0305791	2 C
TR203		0305791	2 B
TR204		0305791	1 C
TR205		0305791	1 C
TR206		0305791	1 B
TR207		0370060	1 A
IC201	LA1111	0360050	2 B
D201		0310330	1 C
D202		0310330	1 C
D203		0310330	1 B
D204		0340030	1 A
D205		0340030	1 A, B
CF201		0910101	2 C
CF202		0910101	2 C
CF203		0910101	2 C
CF204		0910101	2 C
CF205		0910101	2 B
CF206		0910101	2 B

+80%
-20% 50V CC.

±10% 50V CC.

+80%
-20% 50V EC.

±10% 50V CC.

+80%
-20% 50V CC.

±10% 50V CC.

+80%
-20% 50V CC.

+20%
-80% 50V CC.

±10% 50V CC.

±10% 50V MC.

+80%
-20% 50V CC.

±10% 50V CC.

25C930 (D)

2SK24 (E, F)

1N60

DS-410 or DS-430

CFR-10.7M Ceramic Filter

W	X	Y	Z
T201	Discriminator Transformer	4235650	2A
T202		4235770	1B
T203		4235780	1B
L201	3.3μH Micro Inductor	4900100	1C
L202		4900100	1, 2C
L203		4900100	2C
	Printed Circuit Board F-1364-1	2520261	

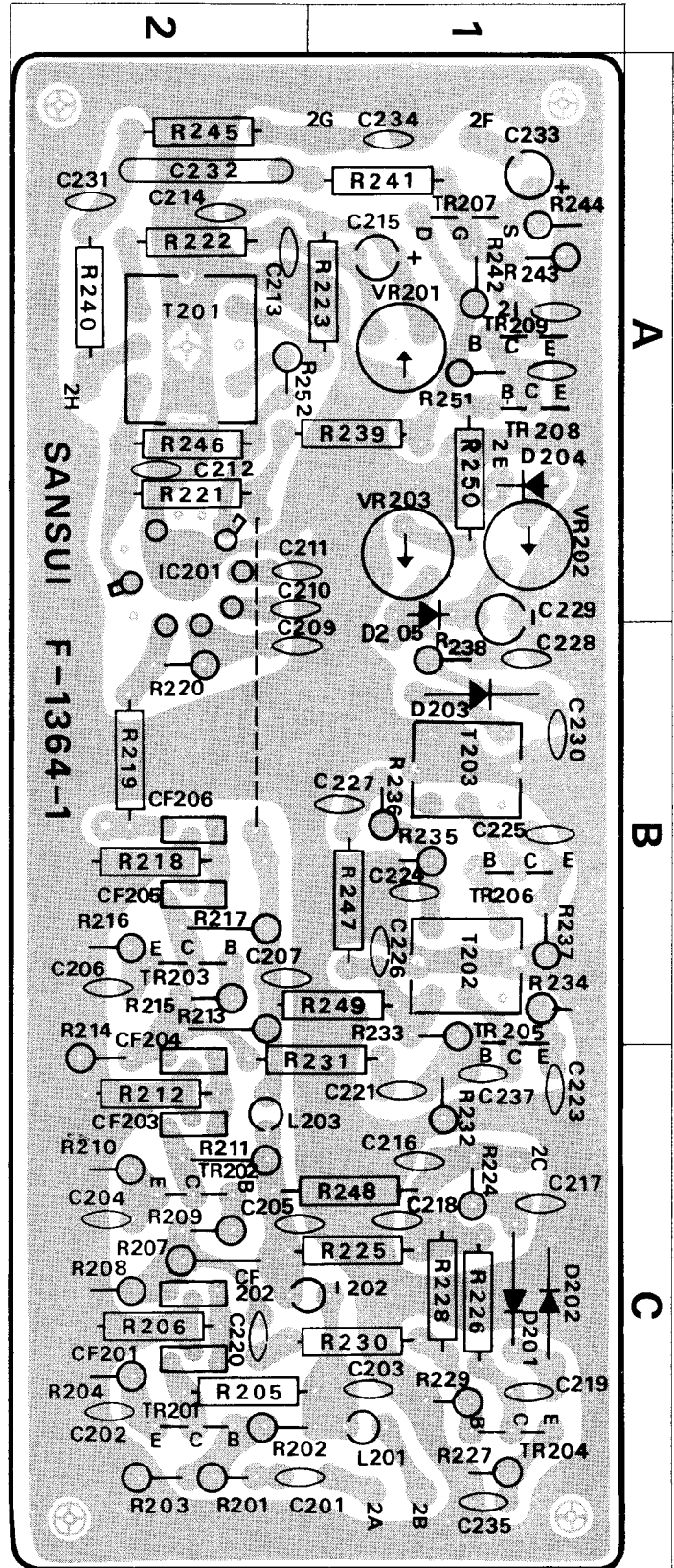

PRINTED CIRCUIT BOARDS AND PARTS LIST

W: Parts No. X: Parts Name Y: Stock No. Z: Position of Parts

FM MPX BLOCK <F-1387-2D>

Stock No. 7540730

W	X	Y	Z
R401	1kΩ	0106102	1C
R402	100kΩ	0106104	1C
R403	4.7kΩ	0106472	1C
R404	22kΩ	0106223	1C
R405	6.8kΩ	0106682	1C
R406	100kΩ	0106104	1B
R407	4.7kΩ	0106472	2B
R408	820Ω	0106821	2B
R409	2.2kΩ	0106222	2B
R410	47kΩ	0106473	1B
R412	1.8kΩ	0106182	1B
R413	22kΩ	0106223	2B
R414	100kΩ	0106104	2B
R415	220kΩ	0106224	1A, B
R416	220kΩ	0106224	1A, B
R417	220kΩ	0106224	1A, B
R418	220kΩ	0106224	1A
R419	10kΩ	0106103	1A
R420	10kΩ	0106103	1A
R421	10kΩ	0106103	1A
R422	10kΩ	0106103	1A
R423	56kΩ	0106563	1A
R424	56kΩ	0106563	1A
R425	100kΩ	0106104	1A
R426	100kΩ	0106104	1A
R427	100kΩ	0106104	1A
R428	100kΩ	0106104	1A
R429	8.2kΩ	0106822	1A
R430	8.2kΩ	0106822	1A
R431	10kΩ	0106103	1A
R432	10kΩ	0106103	2A
R433	1kΩ	0106102	2A
R434	1kΩ	0106102	1A
R435	56kΩ	0106563	2A
R436	56kΩ	0106563	2A
R437	10kΩ	0106103	2A
R438	10kΩ	0106103	2A
R439	1MΩ	0106105	2C
R440	3.3kΩ	0106332	1, 2C
R441	82Ω	0106820	2C
R442	47kΩ	0106473	2C
R443	8.2kΩ	0106822	2C
R444	47kΩ	0106473	2B
R445	47kΩ	0106470	2C
R446	22kΩ	0106223	2C
R447	22kΩ	0106223	2C
R448	1kΩ	0106102	2B, C
R449	10kΩ	0106103	1, 2B
R550	15Ω	0106150	2B
R451	22kΩ	0106223	2B
R452	82Ω	0106820	2B
R453	22kΩ	0106223	2B
R454	22kΩ	0106223	2B
R455	47kΩ	0106473	2B
R456	4.7kΩ	0106472	2B

W	X	Y	Z
R457	4.7kΩ	0107472	2A
R458	47Ω	0106470	2B
R459	47kΩ	0106473	2B
R460	47kΩ	0106473	
R461	47kΩ	0106473	
R462	56kΩ	0106473	
R463	100kΩ	0107104	
VR401	10kΩ (B)	1035130	1A
VR402	220kΩ (B)	1035210	2C
VR403	220kΩ (B)	1035210	2B
C401	68pF ±10%	0660680	1C
C402	3.3μF	0513339	1C
C403	6800pF	0629001	1C
C404	2200pF	0620222	1B
C405	10μF	0513100	1B
C406	1μF	0515109	2B
C411	560pF	0620561	1A
C412	560pF	0620561	1A
C413	0.1μF	0600108	1A
C414	0.1μF	0600108	1A
C415	1000pF	0620102	1A
C416	1000pF	0620102	1A
C417	1μF	0515109	1, 2B
C418	0.0022μF ±5%	0600226	2A
C419	0.47μF	0573478	2A
C420	0.47μF	0573478	1, 2A
C423	1200pF	0620122	2A
C424	1200pF	0620122	2A
C425	0.001μF	0600106	2A
C426	0.001μF	0600106	2A
C427	100pF	0620101	1C
C428	4700pF	0620472	2C
C429	1μF	0515109	2C
C430	0.001μF ^{+80%} / _{-20%}	0657102	
C431	10μF	0513100	2B
C432	0.22μF	0573228	2B
C433	0.047μF ^{+80%} / _{-20%}	0657473	2B
C434	220μF	0513221	2B
C435	0.022μF ^{+80%} / _{-20%}	0657223	
C436	0.047μF ^{+80%} / _{-20%}	0657473	
TR401	2SC871 (F)	0305472	1C
TR402	2SA678 (6)	0300291	1, 2B
TR403	2SC871 (F)	0305472	1A
TR404	2SC871 (F)	0305472	1A
TR405	2SC634A (6)	0305891	2A
TR406	2SC634A (6)	0305891	2A
TR407	2SC711 (F)	0305732	2C
TR408	2SC711 (E, F)	0305731, 2	2C
TR409	2SC711 (E, F)	0305731, 2	2C
TR410	2SC711 (E, F)	0305731, 2	2C
TR411	2SC711 (E, F)	0305731, 2	2B
TR412	2SC634A (6)	0305891	2B

W	X	Y	Z
TR413	2SC711 (F)	0305732	2 B
TR414	2SC711 (E, F)	0305731, 2	2 B
TR415	2SA678 (6)	0305731	2 B
TR416	2SC711 (E, F)	0305731, 2	2 C
D401	1S953	0311050	1 C
D402		0311050	2 B, C
D403		0311060	1 B
D404		0311060	1 B
D405		0311060	1 B
D406		0311060	1 B
D407	1N34A	0310400	2 C
L401	MPX Coil	4240660	1 B, C
L402	2mH Micro Inductor	4900090	1 C
L403		4900090	1 B
L404	MPX Coil	4240650	1 B
L405	1mH Micro Inductor	4900120	2 C
L406		4240640	1 C
L407	MPX Coil	4240570	2 A
L408		4240570	2 A
	Printed Circuit Board F-1387-2	2540260	

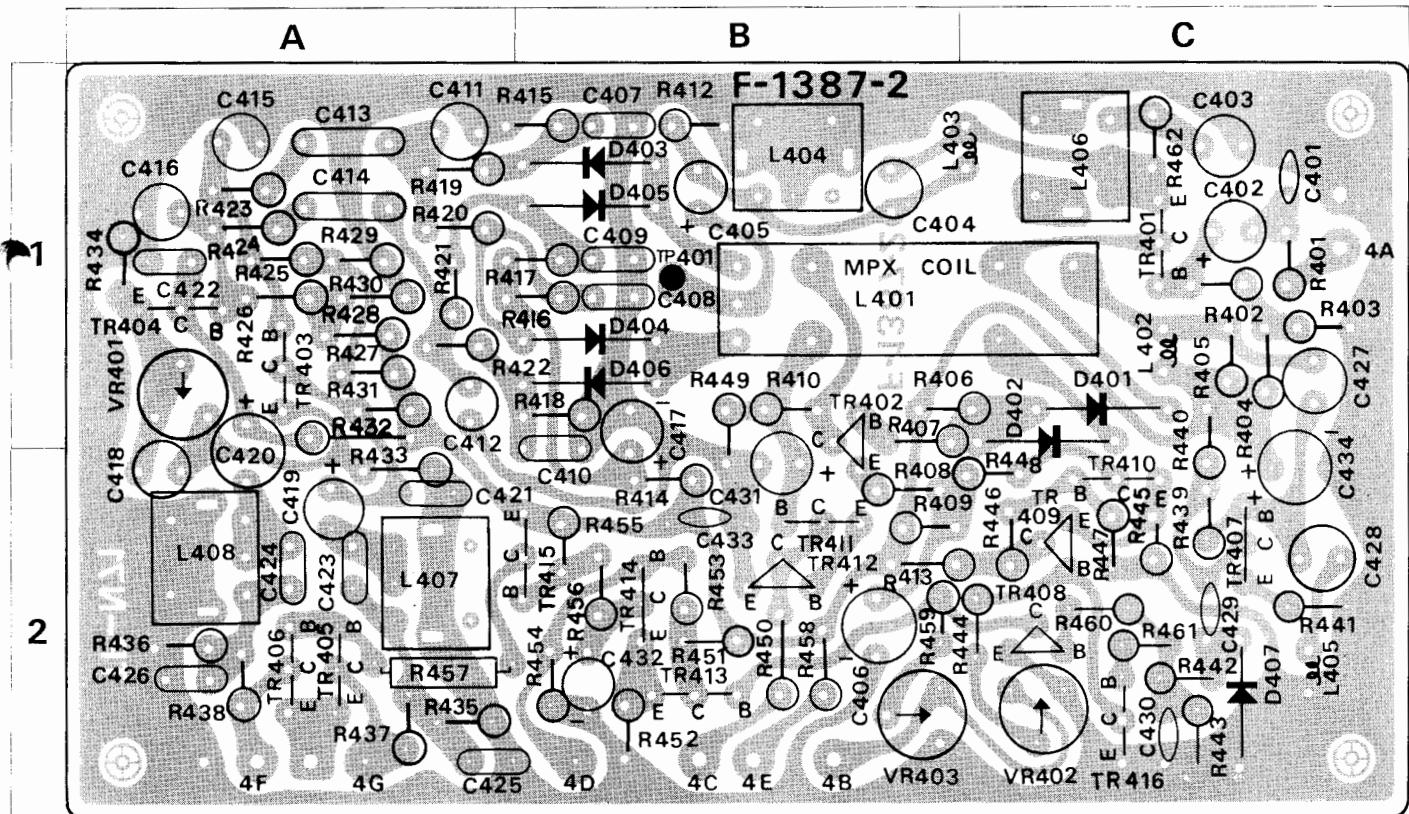

PRINTED CIRCUIT BOARDS AND PARTS LIST

W: Parts No. X: Parts Name Y: Stock No. Z: Position of Parts

EQUALIZER BLOCK <F-1267E>

Stock No. 7550480

W	X	Y	Z
R601	2.2kΩ	0107222	2 B
R602	2.2kΩ	0107222	2 A
R603	220kΩ	0107224	2 B
R604	220kΩ	0107224	2 A
R605	820kΩ	0107824	2 B
R606	820kΩ	0107824	2 A
R607	4.7kΩ	0107472	2 B
R608	4.7kΩ	0107472	2 B
R609	1kΩ	0107102	1 B
R610	1kΩ	0107102	1 A
R611	100kΩ	0107104	1 B
R612	100kΩ	0107104	1 A
R613	2.7kΩ	0107272	1 B
R614	2.7kΩ	0107272	1 A
R615	8.2kΩ	0107822	1 B
R616	8.2kΩ	0107822	1 A
R617	82kΩ	0107823	2 B
R618	82kΩ	0107823	2 A
R619	82kΩ	0107823	1 B
R620	82kΩ	0107823	1 A
R621	2.7kΩ	0107272	1 B
R622	2.7kΩ	0107272	1 A
R623	56kΩ	0107563	1 B
R624	56kΩ	0107563	1 A

± 5% 1/4W CR.

W	X	Y	Z
R625	68kΩ	± 5% 1/4W CR.	0107683 2 B
R626	68kΩ		0107683 2 B
C601	3.3μF	25V TC.	0573339 2 B
C602	3.3μF		0601478 2 A
C605	10pF	±10% 50V CC.	0660100 1 B
C606	10pF		0660100 1 A
C609	47μF	10V EC.	0511470 2 B
C610	47μF		0511470 2 A
C611	0.68μF	25V TC.	0573688 1 B
C612	0.68μF		0573688 1 A
C613	0.0047μF	± 5% 50V MC.	0600476 1 B
C614	0.0047μF		0600476 1 A
C615	0.0012μF	±10% 50V CC.	0600126 1 B
C616	0.0012μF		0600126 1 A
C621	120pF	±10% 50V CC.	0660151 1 B
C622	120pF		0660151 1 A
TR601	2SC1313R(F)	0306070	2 B
TR602		0306070	2 B
TR603		0306070	2 B
TR604		0306070	2 B
Printed Circuit Board F-1267			2550140

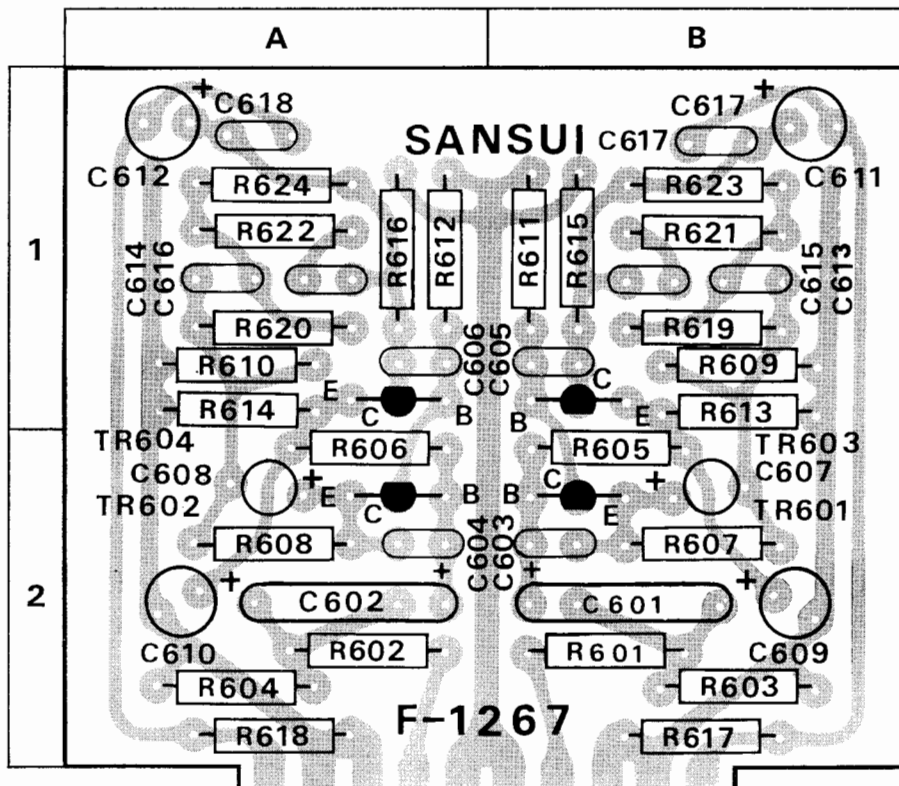

SWITCH BLOCK <F-1365>

Stock No. 7590790

W	X	Y
R045	33kΩ	0107333
R046	33kΩ	0107333
R047	33kΩ	0107333
R048	33kΩ	0107333
} ± 5% 1/4W CR.		
C026	150pF	0660151
C027	150pF	0660151
C028	150pF	0660151
C029	150pF	0660151
} ± 10% 50V CC.		
C030	0.022μF	0601227
C031	0.022μF	0601227
C032	0.022μF	0601227
C033	0.022μF	0601227
} ± 10% 50V MC.		
Printed Circuit Board F-1365		2590750

METER POINTER ILLUMINATION BLOCK <F-2068>

Stock No. 7591450

W	X	Y
R079	10Ω ± 5% 1/4W Fuse Resistor	0191100
PL019	5V 60mA Lamp	0400100, 1
PL020	5V 60mA Lamp	0400100, 1
Printed Circuit Board F-2068		2591420

LAMP HOLDER BLOCK <F-1374>

Stock No. 7590810

W	X	Y
R021	18Ω ± 5% 1/4W CR.	0107180
Fuse Holder Pin (× 10)		2310050
Printed Circuit Board F-1374		2590760

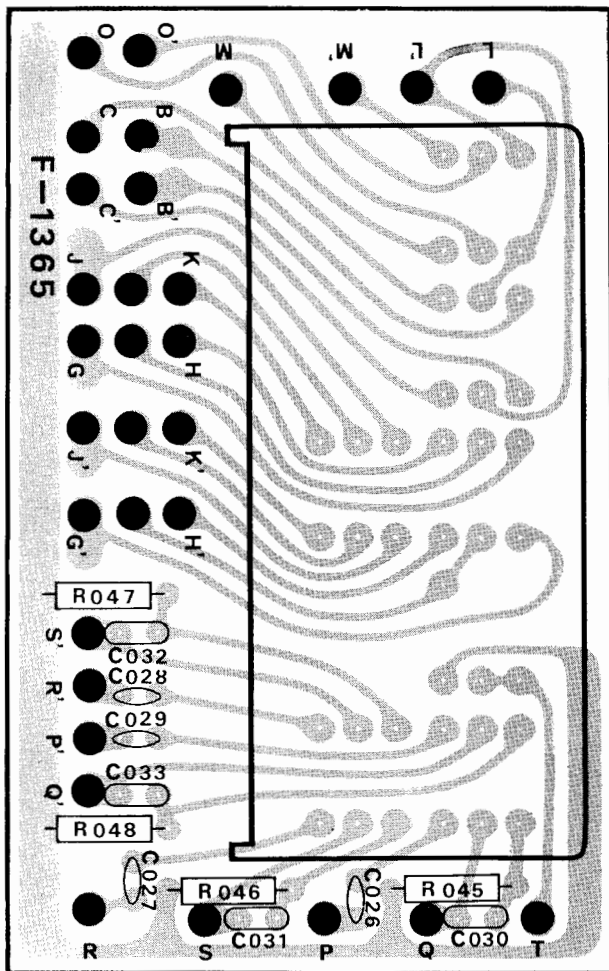

PRINTED CIRCUIT BOARDS AND PARTS LST

W: Parts No. X: Parts Name Y: Stock No. Z: Position of Parts

TONE CONTROL BLOCK (F-1363-1A)

Stock No. 7560640

W	X	Y	Z
R701	2.2kΩ	0107222	1 A
R702	2.2kΩ	0107222	2 B
R705	220kΩ	0107224	1 B
R706	220kΩ	0107224	2 B
R707	39kΩ	0107393	1 B
R708	39kΩ	0107393	2 B
R709	1kΩ	0107102	1 B
R710	1kΩ	0107102	2 B
R711	180kΩ	0107184	1 B
R712	180kΩ	0107184	2 B
R713	6.8kΩ	0107682	1 B
R714	6.8kΩ	0107682	2 B
R715	6.8kΩ	0107682	1 B, C
R716	6.8kΩ	0107682	2 C
R717	2.7kΩ	0107272	1 B, C
R718	2.7kΩ	0107272	2 B, C
R719	5.6kΩ	0107562	1 C
R720	5.6kΩ	0107562	2 C
R721	10kΩ	0107103	1 C
R722	10kΩ	0107103	2 C
R725	22kΩ	0107223	1 C
R726	22kΩ	0107223	2 C
R727	5.6kΩ	0107562	1 C
R728	5.6kΩ	0107562	2 C
R729	10kΩ	0107103	1 C
R730	10kΩ	0107103	2 C
R733	100kΩ	0107104	1 C
R734	100kΩ	0107104	1 C
R735	5.6kΩ	0107562	1, 2 C
R736	5.6kΩ	0107562	2 C
R737	560Ω	0107561	1 C
R738	560Ω	0107561	2 B
R739	100kΩ	0107104	1 C
R740	100kΩ	0107104	2 C
R741	2.2kΩ	0107222	1 A
R742	2.2kΩ	0107222	2 A
R743	680Ω	0107681	1 A
R744	680Ω	0107681	1 A
R745	100kΩ	0107104	1 A
R746	100kΩ	0107104	2 A
R747	12kΩ	0107123	1 A
R748	12kΩ	0107123	2 A
R749	820Ω	0107821	1 A
R750	820Ω	0107821	2 A
R753	100kΩ	0107104	1 A
R754	100kΩ	0107104	2 A
R755	180kΩ	0107184	2 A
R756	180kΩ	0107184	
R757	100Ω	0107101	
C701	0.01μF	0600107	1 A
C702	0.01μF	0600107	2 B
C703	1μF	0515109	1 A
C704	1μF	0515109	2 B
C705	47pF	0660470	1 B
C706	47pF	0660470	2 B

W	X	Y	Z
C707	100μF	0510101	1 B
C708	100μF	0510101	2 B
C711	0.008μF	0600806	1 B
C712	0.008μF	0600806	2 B
C713	10μF	0519001	1 B
C714	10μF	0519001	2 B
C715	0.043μF	0600437	1 B
C716	0.043μF	0600437	2 C
C717	0.043μF	0600437	1 C
C718	0.043μF	0600437	2 C
C719	0.0015μF	0600156	1 C
C720	0.0015μF	0600156	2 C
C721	10μF	0519001	1 C
C722	10μF	0519001	1 C
C723	47pF	0660470	1 C
C724	47pF	0660470	2 C
C725	100μF	0510101	1 C
C726	100μF	0510101	2 C
C727	1μF	0519109	1 C
C728	1μF	0519109	2 C
C729	1μF	0519109	1 A
C730	1μF	0519109	2 A
C733	1μF	0519109	1 A
C734	1μF	0519109	2 A
C735	0.047μF	0657473	2 A
C736	100μF	0513101	
TR701		0305475	1 B
TR702		0305475	2 B
TR703		0305475	1 B
TR704		0305475	2 B
TR705		0305475	1 C
TR706		0305475	2 C
TR707		0305475	1 A
TR708		0305475	2 A
Printed Circuit Board F-1363-1			2560410

FILTER BLOCK <F-1366>

Stock No. 7590800

W	X	Y
R049	1M Ω	0107105
R050	1M Ω	0107105
R051	1M Ω	0107105
R052	1M Ω	0107105
} $\pm 5\%$ $\frac{1}{4}$ W CR.		
Printed Circuit Board F-1366		2590840

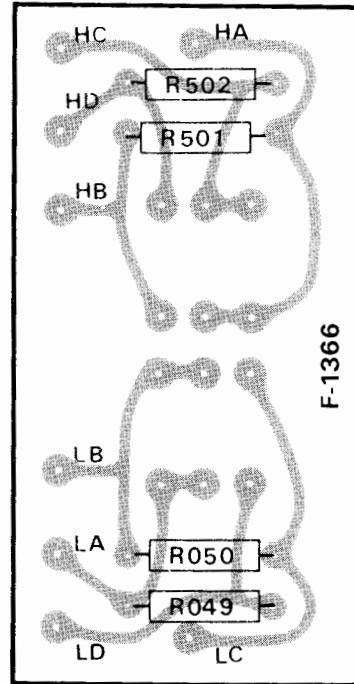
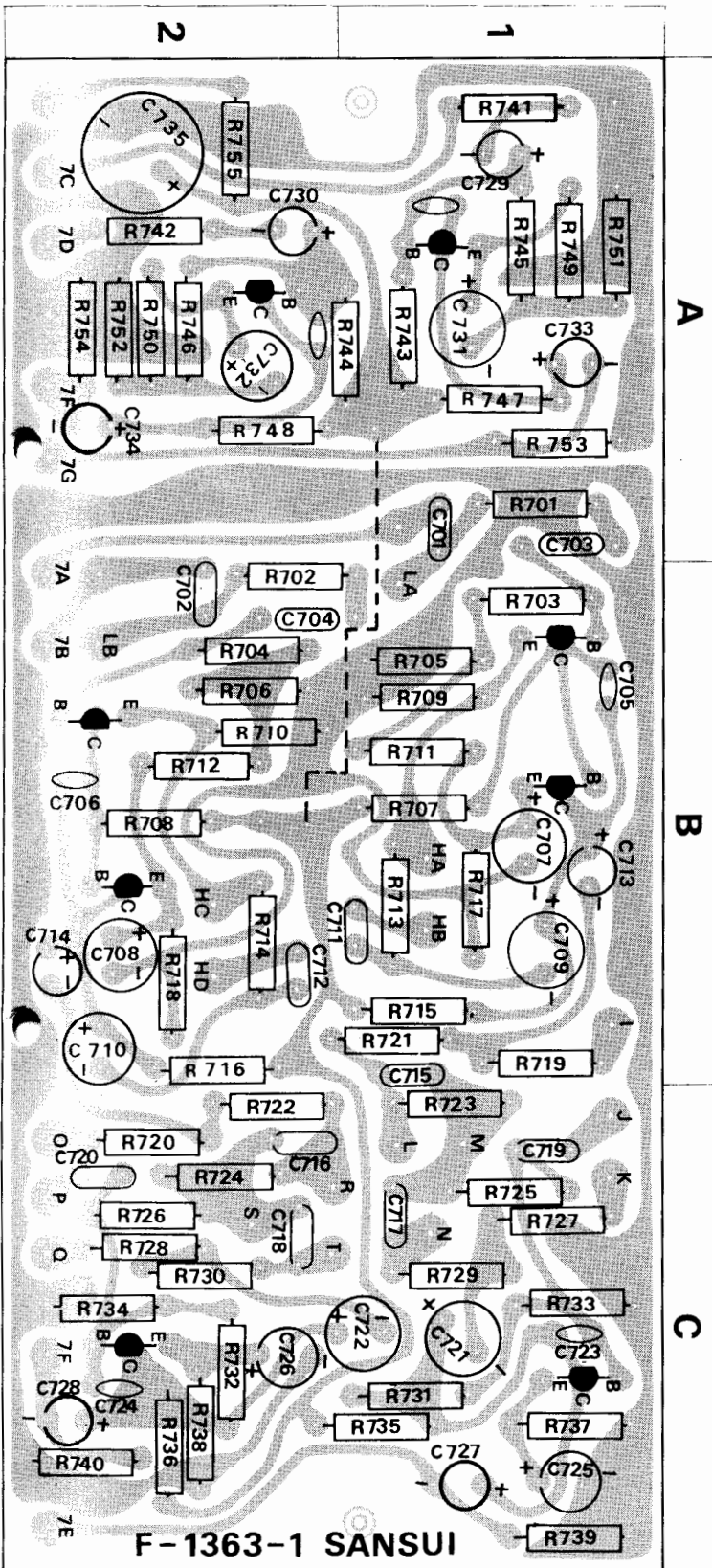

PRINTED CIRCUIT BOARDS AND PARTS LST

W: Parts No. X: Parts Name Y: Stock No. Z: Position of Parts

DRIVER BLOCK <F-1180G>

Stock No. 7570710

W	X	Y	Z
R801	10kΩ	0107103	1 A
R802	150kΩ	0107154	1 A
R803	560kΩ	0107564	1 A
R804	1.2kΩ	0107122	1 A
R805	3.3kΩ	0107332	1 A
R806	3.3kΩ	0107332	1 A
R807	10kΩ	0107103	1 A
R808	47kΩ	0107473	1 A
R809	56kΩ	0107563	1 A
R810	1.8kΩ	0107182	1 B
R811	3.9kΩ	0107392	2 B
R812	39Ω	0107390	2 B
R813	3.3kΩ	0107332	1 B
R814	1.5kΩ	0107152	2 A
R815	220Ω	0107221	2 A
R816	100Ω	0107101	2 B
R817	22Ω	0107479	2 A
R818	100Ω	0107101	2 A
R819	5.6Ω	0111569	2 A
R820	12kΩ	0107123	1 A
R821	10kΩ	0107103	1 C
R822	150kΩ	0107154	1 C
R823	560kΩ	0107564	1 C
R824	1.2kΩ	0107122	1 C
R825	3.3kΩ	0107332	1 C
R826	3.3kΩ	0107332	1 C
R827	10kΩ	0107103	1 C
R828	47kΩ	0107473	1 C
R829	56kΩ	0107563	1 C
R830	1.8kΩ	0107182	1 B
R831	3.9kΩ	0107392	2 B
R832	39Ω	0107390	2 B
R833	3.3kΩ	0107332	1 B
R834	1.5kΩ	0107152	2 C
R835	220Ω	0107221	2 C
R836	100Ω	0107101	2 B
R837	22Ω	0107220	2 C
R838	100Ω	0107101	2 C
R839	5.6Ω	0111569	2 C
R840	12kΩ	0107123	1 C
C801	1μF 50V EC.	0515109	1 A
C802	100μF 25V EC.	0513101	1 A
C803	220μF 10V EC.	0511221	1 A
C804	10μF 25V EC.	0519001	1 A
C805	33μF 50V EC.	0515336	1 B
C806	100μF 10V EC.	0511101	2 A
C807	10μF 50V EC.	0519108	1 B
C808	0.047μF ±10% 50V MC.	0601477	2 A
C809	47pF ±10% 50V CC.	0660470	1 A
C811	1μF 50V EC.	0515109	1 C
C812	100μF 25V EC.	0513101	1 C
C813	220μF 10V EC.	0511221	1 C
C814	10μF 25V EC.	0519001	1 C
C815	33μF 50V EC.	0515330	1 B

W	X	Y	Z
C816	100μF 10V EC.	0511101	2 C
C817	10μF 50V EC.	0519108	1 B
C818	0.047μF ±10% 50V MC.	0601477	2 C
C819	47pF	0660470	1 C
C823	22pF	0660220	2 A
C834	22pF ±10% 50V CC.	0660220	2 C
C825	330pF	0660331	2 B
C826	330pF	0660331	2 B
VR801	200kΩ(B) Left AC Balance Adj.	1031150	1 A, B
VR802	1kΩ(B) Left DC Bias Adj.	1030690	2 A, B
VR803	200kΩ(B) Right AC Balance Adj.	1031150	1 B, C
VR804	1kΩ(B) Right DC Bias Adj.	1030690	2 B, C
TR801	2SC871R (F)	0305475	1 A
TR802	2SC1124 (2, 3)	0305901, 2	2 A
TR803	2SC984 (C)	0305872	2 A, B
TR804	2SC959 (M, L)	0305741, 2	2 B
TR805	2SA606 (M, L) } Pair	0300211, 2	2 A
TR806	2SC871R (F)	0305475	1 C
TR807	2SC1124 (2, 3)	0305901, 2	2 C
TR808	2SC984 (C)	0305872	2 B, C
TR809	2SC959 (M, L)	0305741	2 B
TR810	2SA606 (M, L) } Pair	0300211, 2	2 C
Printed Circuit Board F-1180		2570221	

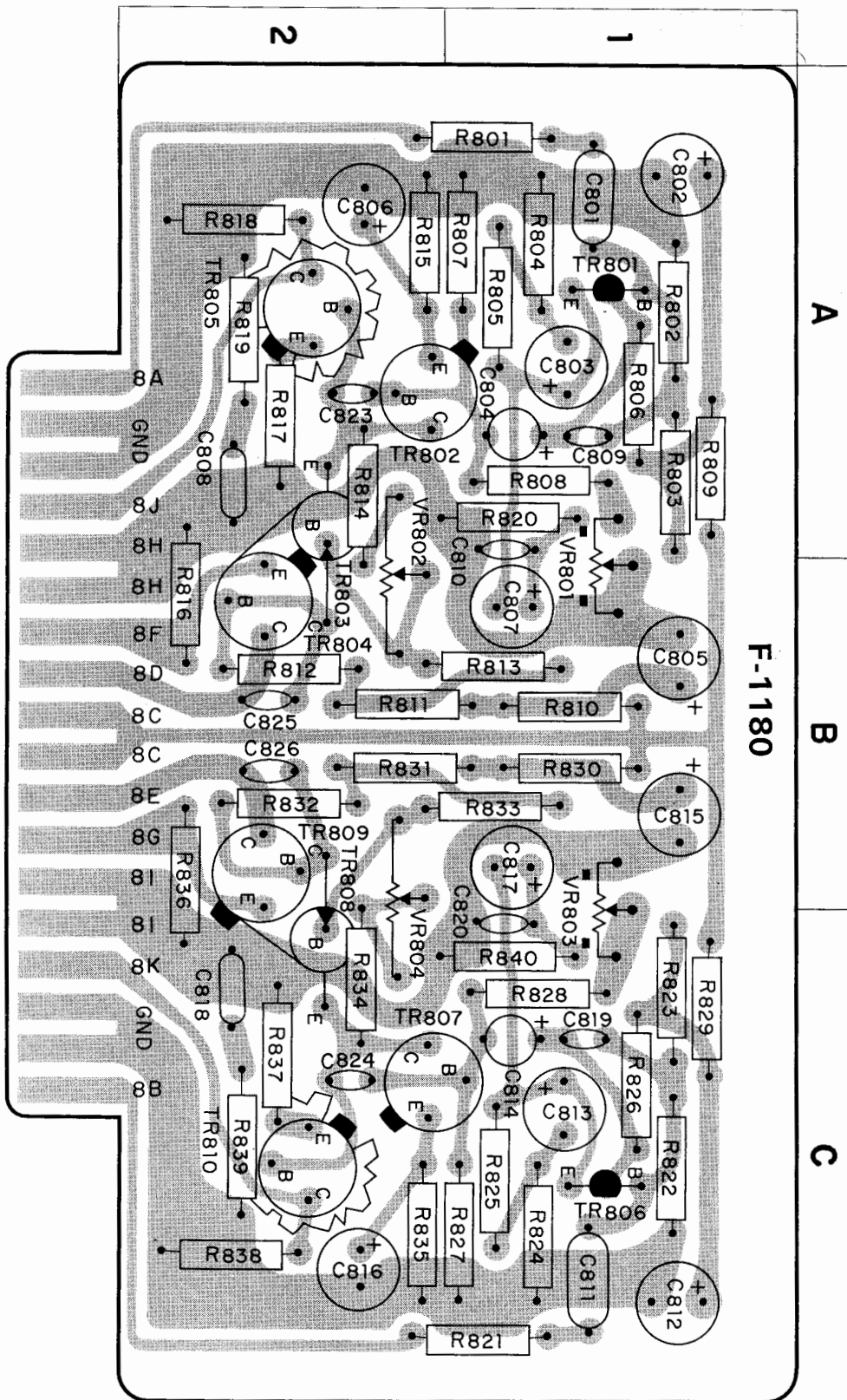

F-1180

PRINTED CIRCUIT BOARDS AND PARTS LIST

W: Parts No. X: Parts Name Y: Stock No. Z: Position of Parts

POWER SUPPLY BLOCK <F-1454>

Stock No. 7500760

W	X	Y	Z
R001	8.2kΩ	± 5% ¼W CR.	0106822 A
R002	8.2kΩ		
R003	2.2Ω	±10% 5 W CeR.	0155229 A
R004	2.7kΩ	± 5% ¼W CR.	0106272 A
R005	15kΩ		
R007	100Ω	± 5% ½W CR.	0103101 B
R009	180Ω	±10% 5 W CeR.	0135181 A
R010	12kΩ	± 5% ¼W CR.	0106123 B
VR030	10kΩ(B) DC Bias Adj.		1035130 A
C004	220μF	50V EC.	0515221 A, B
C005	10μF	10V EC.	0511100 A
C006	100μF	50V EC.	0515101 A, B
C007	100μF		
C008	470μF	16V EC.	0512471 B
C009	220pF	±10% 50VCC.	0560221 A

W	X	Y	Z
C010	100μF	75V EC.	0519301 B
C011	470μF	10V EC.	0511471 B
C029	470μF	25V EC.	0513471 B
TR002	2SC1211(C, D)	0305930, 1	A
TR003			A
TR004			2SC959(K, L)
ZD001	RD6A(N)	0315560	A
ZD002	ZB1-13	0310730	B
D003	SR1-FM2	0310870	A
D004		0310870	A
D005		0310870	B
D006		0310870	B
		Printed Circuit Board F-1454	2500640

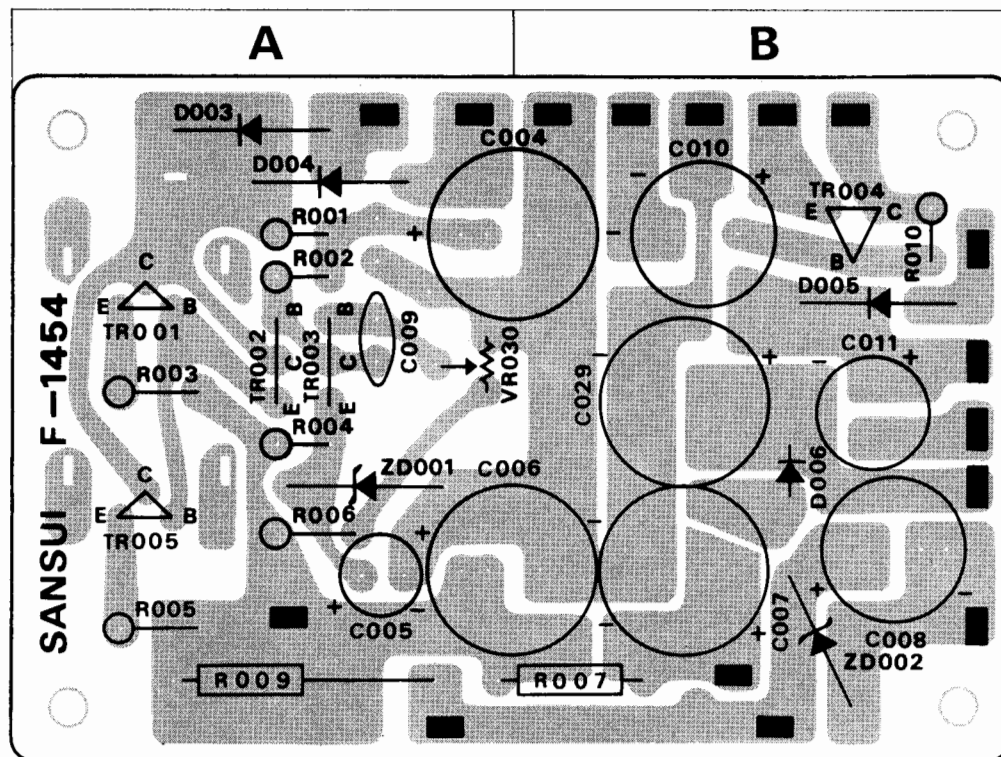

OTHER PARTS AND THEIR LOCATION ON CHASSIS

W: Parts No. X: Parts Name Y: Stock No.

OTHER PARTS

W	X	Y
R012	270Ω	0107271
R022	47Ω	0107470
R024	100kΩ	0107104
R025	100kΩ	0107104
R026	390kΩ	0107394
R027	390kΩ	0107394
R029	100kΩ	0107104
R030	100kΩ	0107104
R031	390kΩ	0107394
R032	390kΩ	0107394
R033	100kΩ	0107104
R034	100kΩ	0107104
R035	390kΩ	0107394
R036	390kΩ	0107394
R037	100kΩ	0107104
R038	470kΩ	0107474
R039	470kΩ	0107474
R041	100kΩ	0107104
R042	100kΩ	0107104
R043	100kΩ	0107104
R044	100kΩ	0107104
R053	330Ω	0111331
R054	330Ω	0111331
R055	330Ω	0111331
R056	330Ω	0111331
R057	0.47Ω	0132478
R058	0.47Ω	0132478
R059	0.47Ω	0132478
R060	0.47Ω	0132478
R061	0.47Ω	0132478
R062	0.47Ω	0132478
R063	0.47Ω	0132478
R064	0.47Ω	0132478
R065	120kΩ	0107124
R066	120kΩ	0107124
R067	120kΩ	0107124
R068	120kΩ	0107124
R069	560Ω	0111561
R070	560Ω	0111561
R071	560Ω	0111561
R072	560Ω	0111561
R073	4.7Ω	0111479
R075	22kΩ	0107223
R076	22kΩ	0107223
R077	22kΩ	0107223
R078	22kΩ	0107223
R079	10Ω	0103100
VR003-006	250kΩ(B) × 4	Volume Control 1060120, 1
VR007-010	250kΩ(MN) × 2	Main Balance Control 1040100, 1
VR011, 012	250kΩ(MN)	Front Balance Control 1040090, 1
VR013, 014	250kΩ(MN)	Rear Balance Control 1040090, 1
VR015, 016	100kΩ(B) × 2	Treble Control 1020200, 1
VR017, 018	100kΩ(B) × 2	Bass Control 1020200, 1
C001	4700μF	63V EC. 0559508
C002	4700μF	0559508

W	X	Y
C003	1000μF	50V EC. 0559302
C013-016	0.05μF × 4 ± 10%	50V CC. 0800121
C017	470μF	50V EC. 0505471
C019	100μF	50V EC. 0505101
C020	0.047μF +80% -20%	50V CC. 0657473
C021	0.033μF ± 20%	250V MPC. 0605337
C022	0.01μF	± 10% 400V OC. 0595107
C023	0.01μF	± 10% 400V OC. 0595107
C038	0.022μF +80% -20%	25V CC. 0656223
C039	0.022μF	0656223
C040	47μF	6.3V EC. 0510470
C041	150pF	0660151
C042	150pF	± 10% 50V CC. 0660151
C043	150pF	0660151
C044	150pF	0660151
C045	0.0047μF ± 20%	250V MPC. 0605476
C047	0.01μF	± 10% 400V OC. 0595107
C048	0.01μF	± 10% 400V OC. 0595107
C051	470pF	± 5% 50V SC. 0620471
C052	470pF	0620471
C053	1000μF	10V EC. 0501102
C054	470μF	0501471
C055	47pF ± 10%	50V CC. 0660470
C084	4700μF	0559322
C085	4700μF	50V EC. 0559322
C086	4700μF	0559322
C087	4700μF	0559322
TR001	25C1111 (R, O, Y)	0305830, 1, 2
TR004-011	25C634A (5~8)	0305890, 1, 2, 3
TR012	25C634A (5~8)	0305890, 1, 2, 3
D001, 002	5B2	0310660
D007	SR1FM2	0310870
S1	Selector Control	1107010, 1
S2	Synthesizer/Decoder Function Control	1105140, 1
S3	Mode Switch	1105150, 1
S4	2-CH-1 Tape Monitor Switch	1130420
S5	2-CH-2 Tape Monitor Switch	
S6	4-CH Tape Monitor Switch	
S7	Loudness Switch	
S8	FM Muting Switch	1130380
S9	High Filter Switch	
S10	Low Filter Switch	1130380
S11	Front Speakers Switch	1101470, 1
S12	Rear Speakers Switch	1101470, 1
S13	Power Switch	1130350
S14	De-emphasis Switch	1110090
PT001	Power Transformer	4001000
L002	AM Bar Antenna	4200490
L003	150μH Ferri Inductor	4900080
L101	75Ω : 300Ω Baloon	4290021
CF207	SFA-10.7M Ceramic Filter	0910100
M001	Signal Meter	4300610

OTHER PARTS AND THEIR LOCATION ON CHASSIS

W: Parts No. X: Parts Name Y: Stock No.

OTHER PARTS

W	X	Y
J001	Front Headphones Jack	2430000
J002	Rear Headphones Jack	2430060
J003	TAPE REC Jack	2430071
J004	PLAYBACK Jack	2430071
DIN001	2-CH TAPE REC/PLAY DIN Socket	2430040
DIN002	4-CH FRONT TAPE REC/PLAY DIN Socket	2430040
DIN003	4-CH REAR TAPE REC/PLAY DIN Socket	2430040
CO001 ~003	AC Outlet	2450040
PL001	6.3V 75mA Dial Pointer Lamp	0400200
PL001~006	7V 330mA Dial Scale Lamp	0420040
PL007	7V 160mA PHONO-2 Indicator	0400153
PL008	7V 160mA PHONO-1 Indicator	0400153
PL009	7V 160mA FM Indicator	0400153
PL010	7V 160mA AM Indicator	0400153
PL011	7V 160mA AUX (2-CH) Indicator	0400153
PL012	7V 160mA DISCRETE Indicator	0400153
PL013	7V 160mA 4-Channel Indicator	0400153
PL014	7V 160mA 2, 4 Digital Indicator	0400154

W	X	Y	
PL015	6.3V 75mA	2, 4 Digital Indicator	0400154
PL016	6.3V 75mA		
PL017	7V 330mA Signal Meter Lamp		0420040
PL018	6V 100mA FM Stereo Indicator		0400161
F001	5A 250V (100~127V) Power Fuse		0430062
	3A 250V (220~250V) Power Fuse		0430042
	Power Fuse Holder		2300060
F002~005	2.5A 250V Quick-Acting Fuse		0433242
	Quick-Acting Fuse Holder		2300070
PU001	Voltage Selector		
	Main Plug		2410180
	Sub Plug		2410190
	Socket		2410170
	FM Frontend (PA4313U06)		7510600
	Printed Circuit Board	F-1382	2590820
		F-1383	2590850
		F-1395	2590860
		F-1463	2591460
		F-6023 (x2)	2591430

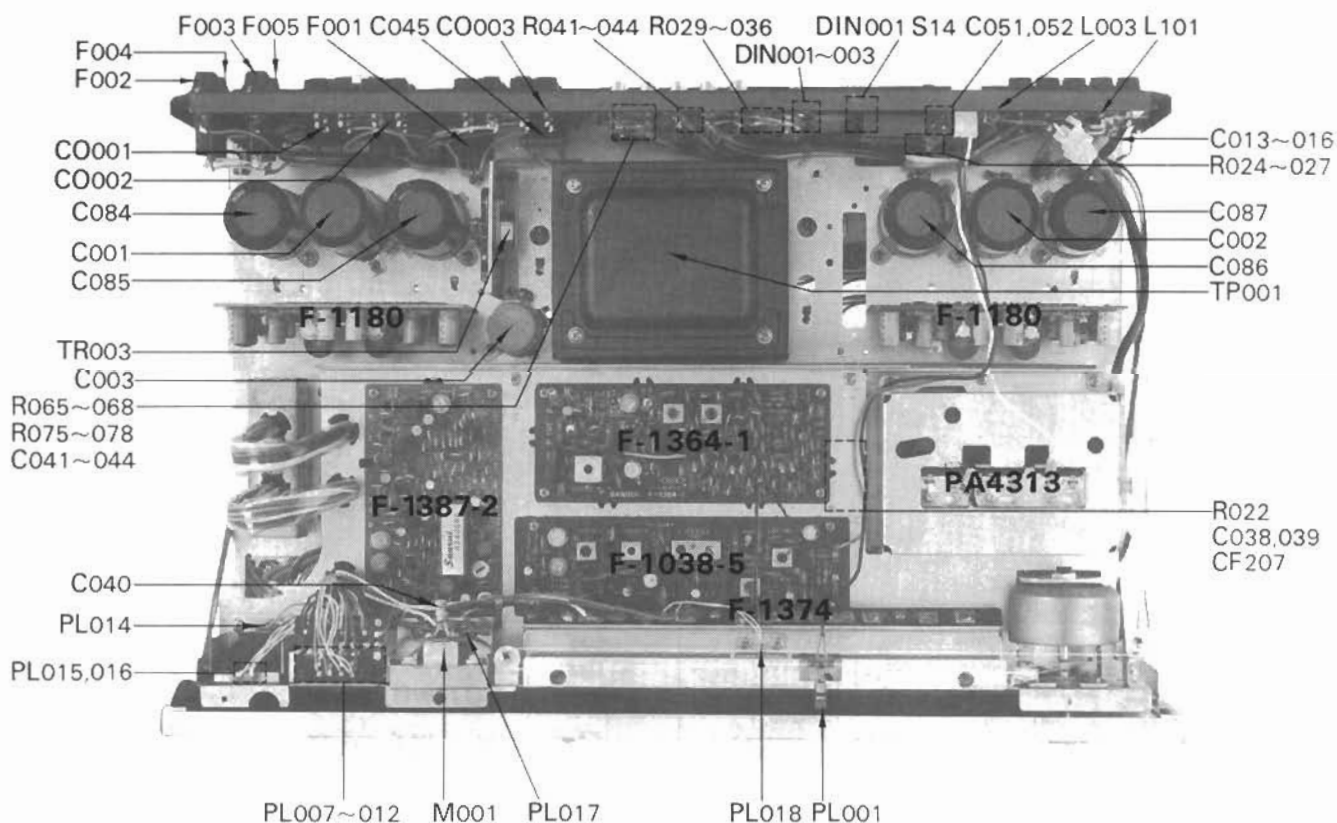

* Design and specifications subject to change without notice for improvements.

W	X	Y
	Vario-Matrix Block F-2047	7650110
	Printed Circuit Board F-2047	2650090
	Fixed Matrix Block F-2048	7650120
	Printed Circuit Board F-2048	2650100
	Power Supply Cord	3800130, 1
	Multi-Connector 10-Pin (× 2)	2420030
	14-Pin (× 4)	2420040
	18-Pin (× 3)	2420020

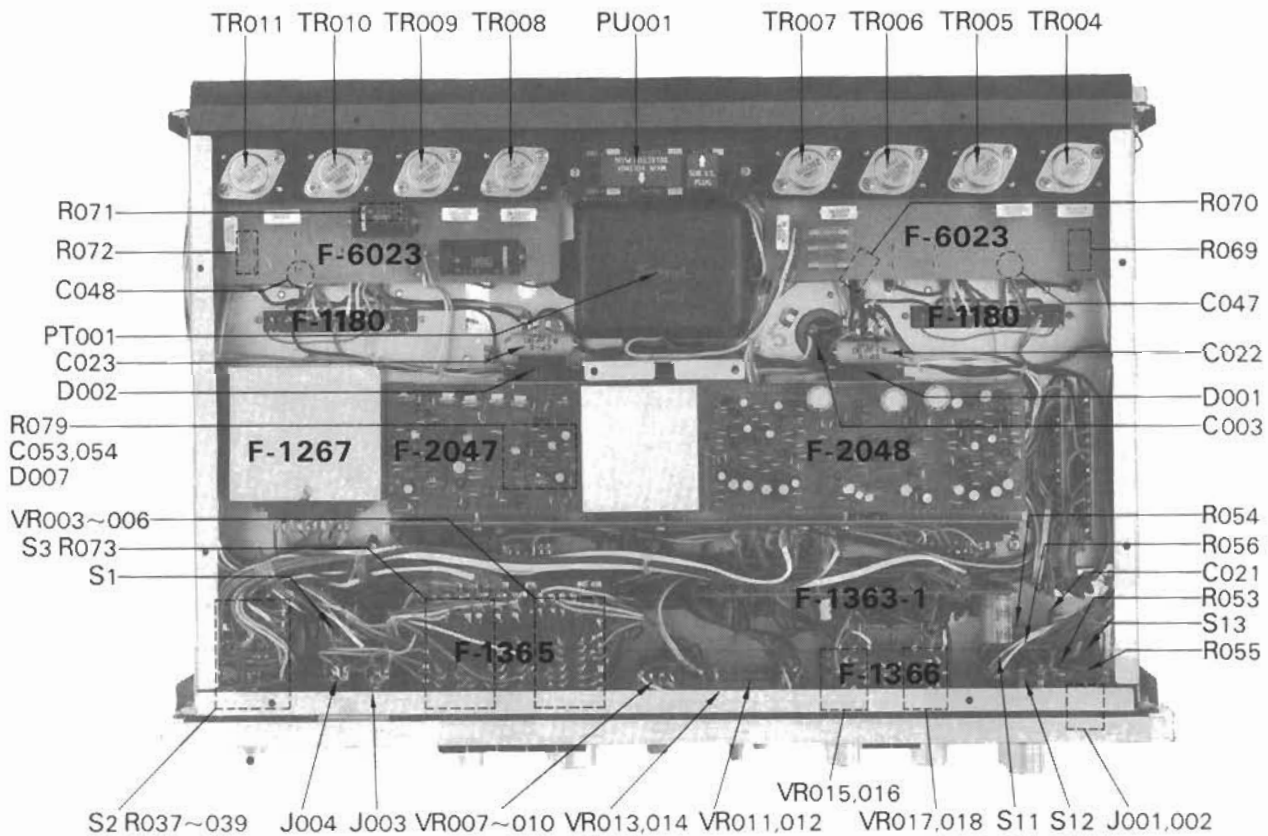



SANSUI ELECTRIC CO., LTD.

14-1, 2-chome, Izumi, Suginami-ku, Tokyo 168, Japan
TELEPHONE: (03) 323-1111/TELEX: 232-2076

Stock No. 9207500

Printed in Japan (D2150M2)