



# SERVICE MANUAL

4-CHANNEL RECEIVER

**SANSUI QRX-8001/9001**



*Sansui*

SANSUI ELECTRIC CO., LTD.

## TABLE OF CONTENTS

<u>Section</u>	<u>Title</u>	<u>Page</u>
<b>1. SPECIFICATIONS</b>		<b>1, 2</b>
<b>2. BLOCK DIAGRAM</b>		<b>3</b>
2- 1.	QRX-8001	3
2- 2.	QRX-9001	3, 4
<b>3. OPERATION OF FM DOLBY SYSTEM</b>		<b>5</b>
<b>4. ADJUSTMENTS</b>		<b>6</b>
4- 1.	Audio Section	6, 7
4- 2.	Tuner Section	7, 8, 9, 10, 11
4- 3.	Dolby Circuit Adjustment (QRX-9001 Only)	11, 12
<b>5. PARTS LOCATION &amp; PARTS LISTS</b>		<b>13</b>
5- 1.	F-2636 Volume & Filter Circuit Board	13
5- 2.	F-2634 4-ch Function Switch & REC CAL Tone Circuit Board	13
5- 3.	F-2638 Power Supply Circuit Board	14
5- 4.	F-2637 Tone Control Circuit Board	14
5- 5.	F-2639 Pre-Power Supply Circuit Board	14
5- 6.	F-2614 Tuner Circuit Board	14
5- 7.	F-2615 Tuner Sub Circuit Board	14
5- 8.	F-2590 Tuner Circuit Board	15
5- 9.	F-2624 Driver Circuit Board	15
5-10.	F-2632 Selector Circuit Board	15
5-11.	F-2642 Indicator Circuit Board	15
5-12.	F-2087 QS Matrix Circuit Board	16
5-13.	F-2088 QS Phase Discriminator Section Circuit Board	16
5-14.	F-2689 Protector Circuit Board	16
5-15.	F-2589 Equalizer & CD-4 Circuit Board	17
5-16.	F-2688 Dolby Circuit Board	17
5-17.	F-2640 Illumination Circuit Board (1)	17
5-18.	F-2641 Illumination Circuit Board (2)	17
5-19.	F-2635 4-ch Function Switch & REC CAL Tone Sub Circuit Board	17
5-20.	F-2633 Dolby Change Circuit Board	18
5-21.	F-2686 4-ch Function Switch & REC CAL Tone Sub Circuit Board	18
5-22.	F-2652 Dolby Sub Circuit Board	18
5-23.	Figures	18
<b>6. OTHER PARTS</b>		<b>19</b>
6- 1.	QRX-8001	19
6- 2.	QRX-9001	20
6- 3.	Exploded View (QRX-8001/9001)	20
<b>7. SCHEMATIC DIAGRAM</b>		<b>21</b>
7- 1.	QRX-8001 Tuner Section	21
7- 2.	QRX-8001 Audio Section	22
7- 3.	QRX-9001 Tuner Section	23
7- 4.	QRX-9001 Audio Section	24
7- 5.	QRX-8001/9001 4-Channel Section	25
<b>8. THREADING OF DIAL CORD</b>		<b>26</b>
8- 1.	Threading of Dial Cord	26
8- 2.	Attachment of Dial Pointer	26
<b>9. PACKING LIST</b>		<b>BACK COVER</b>
<b>10. ACCESSORY PARTS LIST</b>		<b>BACK COVER</b>

## 1. SPECIFICATIONS

### AUDIO SECTION

<QRX-8001>

#### POWER OUTPUT

Min. RMS. four channels driven, from 20 to 20,000Hz, with no more than 0.3% total harmonic distortion

40 watts per channel into 8 ohms

40 watts per channel into 4 ohms

Min RMS four channels driven at 1,000Hz with no more than 0.3% total harmonic distortion

43 watts per channel into 8 ohms

43 watts per channel into 4 ohms

Min. RMS. both channels driven from 20 to 20,000Hz, with no more than 0.3% total harmonic distortion and SPEAKERS/MODE switch at 2-CH A (POWER × 2)

100 watts per channel into 8 ohms

Min RMS both channels driven at 1,000Hz with no more than 0.3% total harmonic distortion and SPEAKERS MODE switch at 2-CH A (POWER × 2)

110 watts per channel into 8 ohms

<QRX-9001>

#### POWER OUTPUT

Min. RMS. four channels driven, from 20 to 20,000Hz, with no more than 0.3% total harmonic distortion

60 watts per channel into 8 ohms

60 watts per channel into 4 ohms

Min RMS four channels driven at 1,000Hz with no more than 0.3% total harmonic distortion

65 watts per channel into 8 ohms

65 watts per channel into 4 ohms

Min. RMS. both channels driven, from 20 to 20,000Hz, with no more than 0.3% total harmonic distortion and SPEAKERS/MODE switch at 2-CH A (POWER × 2)

120 watts per channel into 8 ohms

Min RMS both channels driven at 1,000Hz with no more than 0.3% total harmonic distortion and SPEAKERS MODE switch at 2-CH A (POWER × 2)

140 watts per channel into 8 ohms

<QRX-8001> <QRX-9001>

#### LOAD IMPEDANCE

SPEAKERS/MODE Switch at 2-CH—A, 4-CH—A and 4-CH—B  
4 and 8 ohms

SPEAKERS/MODE switch at 2-CH—A(POWER × 2) and 4-CH—A+B  
8 ohms

POWER BANDWIDTH.....20 to 20,000Hz at or below  
rated min. RMS power output  
and total harmonic distortion

#### TOTAL HARMONIC DISTORTION

less than 0.3% at or below  
rated min. RMS power output

INTERMODULATION DISTORTION (70Hz: 7kHz 4:1 SMPTE  
method).....less than 0.3%

#### FREQUENCY RESPONSE (at 1 watt)

20 to 30,000Hz ±1dB

#### RIAA CURVE DEVIATION (PHONO)

±1.0dB, -1.0dB (30Hz to 15kHz)

#### DAMPING FACTOR

approximately 30 at 8-ohm load

#### INPUT SENSITIVITY AND IMPEDANCE

(1kHz, for rated power output)

PHONO (2-channel) .....2.5mV/50 kilohms

(Max. input capability: 150mV at 1kHz, less than 0.3%  
total harmonic distortion.)

TAPE PLAY (pin jacks) ....100mV/50 kilohms

TAPE-1 REC/PLAY (DIN socket)

.....100mV/50 kilohms

AUX .....100mV/50 kilohms

MIC .....4mV/10 kilohms

#### RECORDING OUTPUT

TAPE REC (pin jacks) .....100mV

TAPE-1 REC/PLAY (DIN socket)

.....30mV

#### CHANNEL SEPARATION (at rated output 1kHz)

PHONO .....better than 45dB

TAPE PLAY, AUX .....better than 45dB

#### HUM AND NOISE

PHONO .....better than 70dB

TAPE PLAY, AUX .....better than 80dB

**CONTROLS**

- BASS ..... ±10dB (50Hz)
- TREBLE ..... ±10dB (10kHz)
- LOUDNESS ..... +8dB (50Hz)  
+3dB (10kHz)
- LOW FILTER ..... -10dB (50Hz)
- HIGH FILTER ..... -10dB (10kHz)
- AUDIO MUTING ..... -20dB

**4-CHANNEL DECODER SECTION**

- QS DECODER (Type-A QS vario-matrix)\*
- SEPARATION ..... 20dB between adjacent channels  
30dB between diagonal channels
  - DISTORTION ..... less than 0.1% (at 1kHz)
  - FREQUENCY RESPONSE... 20 to 30,000Hz

- QS SYNTHESIZER (Type-A QS vario-matrix)
- SEPARATION ..... equivalent to QS decoder
  - DISTORTION ..... equivalent to QS decoder
  - FREQUENCY RESPONSE... equivalent to QS decoder

- SQ FUNCTION (Phase Matrix)\*\*
- SEPARATION ..... 20dB (left front to right front)  
12dB (center front to center back)

**CD-4 DEMODULATOR\*\*\***

- INPUT SENSITIVITY ..... 2.5mV
- INPUT IMPEDANCE ..... 50 kilohms
- SEPARATION (Standard test signal at 1kHz)  
..... 40dB (left to right)  
25dB (front to back)
- FREQUENCY RESPONSE (Standard test signal at REC output)  
..... 30 to 15,000Hz (main-channel)

**<QRX-9001 Only>**

- DOLBY NOISE REDUCTION EFFECT†  
..... 10dB (above 5kHz)

**FM SECTION**

- <QRX-8001>**
- TUNING RANGE ..... 88 to 108MHz
  - USABLE SENSITIVITY (IHF) ... 10.8dBf (1.9µV)  
(DIN) .. 1.1µV  
(1kHz, Modulation 30%, S/N 26dB)

- 50dB QUIETING SENSITIVITY
- STEREO (IHF) ..... 38dBf (45µV)
  - MONO (IHF) ..... 16dBf (3.5µV)

- TOTAL HARMONIC DISTORTION
- STEREO ..... less than 0.5% (1kHz)
  - MONO ..... less than 0.4% (1kHz)

- SIGNAL TO NOISE RATIO
- STEREO ..... better than 60dB
  - MONO ..... better than 65dB

- ALTERNATE CHANNEL SELECTIVITY  
..... better than 60dB (±400kHz)

- CAPTURE RATIO ..... less than 2.2dB  
AM SUPPRESSION ..... better than 50dB  
IMAGE RESPONSE RATIO (IHF)

- ..... better than 50dB (98MHz)
- IF RESPONSE RATIO (IHF) ... better than 75dB (98MHz)
- SPURIOUS RESPONSE RATIO (IHF)  
..... better than 70dB (98MHz)

- SPURIOUS RADIATION ..... less than 34dB
- STEREO SEPARATION ..... better than 30dB (100Hz)  
better than 40dB (1kHz)  
better than 25dB (10kHz)
- FREQUENCY RESPONSE (IHF) .. +1.0dB, -3.0dB (30 to 15,000Hz)
- ANTENNA IMPEDANCE ..... 75 ohms unbalanced  
300 ohms balanced

**<QRX-9001>**

- TUNING RANGE ..... 88 to 108MHz
- USABLE SENSITIVITY (IHF) ... 10.3dBf (1.8µV)  
(DIN) .. 1.0µV  
(1kHz, Modulation 30%, S/N 26dB)

- 50dB QUIETING SENSITIVITY
- STEREO (IHF) ..... 38dBf (45µV)
- MONO (IHF) ..... 15.6dBf (3.3µV)

- TOTAL HARMONIC DISTORTION
- STEREO ..... less than 0.4% (1kHz)
  - MONO ..... less than 0.3% (1kHz)

- SIGNAL TO NOISE RATIO
- STEREO ..... better than 65dB
  - MONO ..... better than 70dB

- ALTERNATE CHANNEL SELECTIVITY  
..... better than 80dB (±400kHz)

- CAPTURE RATIO ..... less than 1.5dB  
AM SUPPRESSION ..... better than 50dB  
IMAGE RESPONSE RATIO (IHF)

- ..... better than 75dB (98MHz)
- IF RESPONSE RATIO (IHF) ... better than 95dB (98MHz)

**AM SECTION**

- <QRX-8001, QRX9001>**
- TUNING RANGE ..... 535 to 1,605kHz
  - SENSITIVITY (Bar antenna) ... 50dB/m (1,000kHz)
  - SELECTIVITY ..... better than 35dB (1,000kHz)
  - IMAGE RESPONSE RATIO (IHF) better than 35dB (1,000kHz)
  - IM RESPONSE RATIO (IHF) ... better than 30dB (1,000kHz)

**OTHERS**

- <QRX-8001>**
- POWER REQUIREMENTS
- POWER VOLTAGE ..... 100, 120, 220, 240V 50/60Hz  
120V (Usable 110—130V)  
60Hz (for U.S.A. & Canada only)

- POWER CONSUMPTION
- MAXIMUM CONSUMPTION  
..... 550 watts
- RATE CONSUMPTION .. 370 watts (430 VA)
- DIMENSIONS ..... 600mm (23<sup>5</sup>/<sub>8</sub>" W  
174mm (6<sup>7</sup>/<sub>8</sub>" H  
415mm (16<sup>3</sup>/<sub>8</sub>" D)
- WEIGHT ..... 23.6kg (52.0 lbs) net  
26.4kg (58.2 lbs) packed

**<QRX-9001>**

- POWER REQUIREMENTS
- POWER VOLTAGE ..... 100, 120, 220, 240V 50/60Hz  
120V (Usable 110—130V)  
60Hz (for U.S.A. & Canada only)

- POWER CONSUMPTION
- MAXIMUM CONSUMPTION  
..... 860 watts
- RATE CONSUMPTION .. 580 watts (675 VA)
- DIMENSIONS ..... 600mm (23<sup>5</sup>/<sub>8</sub>" W  
174mm (6<sup>7</sup>/<sub>8</sub>" H  
415mm (16<sup>3</sup>/<sub>8</sub>" D)
- WEIGHT ..... 23.0kg (50.7 lbs) net  
25.8kg (56.9 lbs) packed

\* QS is a trademark of Sansui.  
\*\* SQ is a trademark of CBS, Inc.  
\*\*\* CD-4 is a trademark of JVC. Inc.

† The word "Dolby" and the Double-D symbol are a trademark of Dolby Laboratories Inc.  
o Noise reduction circuit made under license from Dolby Laboratories Inc.

\* Design and specifications subject to change without notice for improvements.

## 2. BLOCK DIAGRAM

### 2-1. QRX-8001

Note: This Block Diagram is indicates only L-CH before Audio Muting.

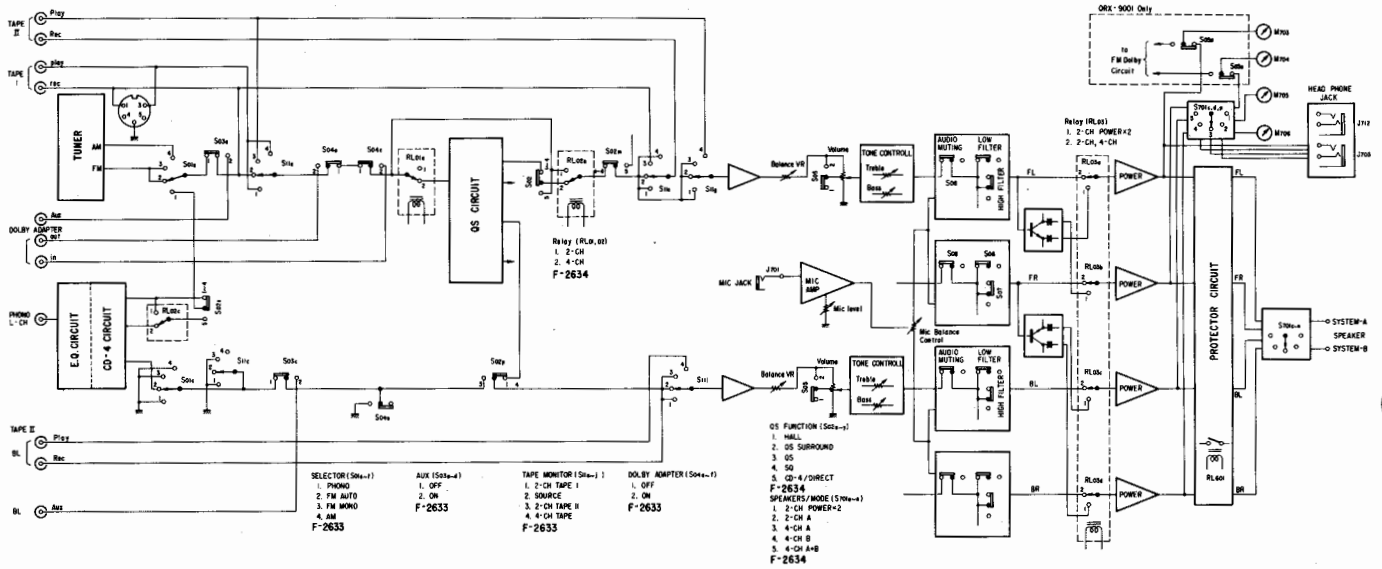

### 2-2. QRX-9001

Note: Follow Block Diagram QRX-8001 above after the Balance Volume.

#### (a) Dolby Operation (FM Dolby Mode)

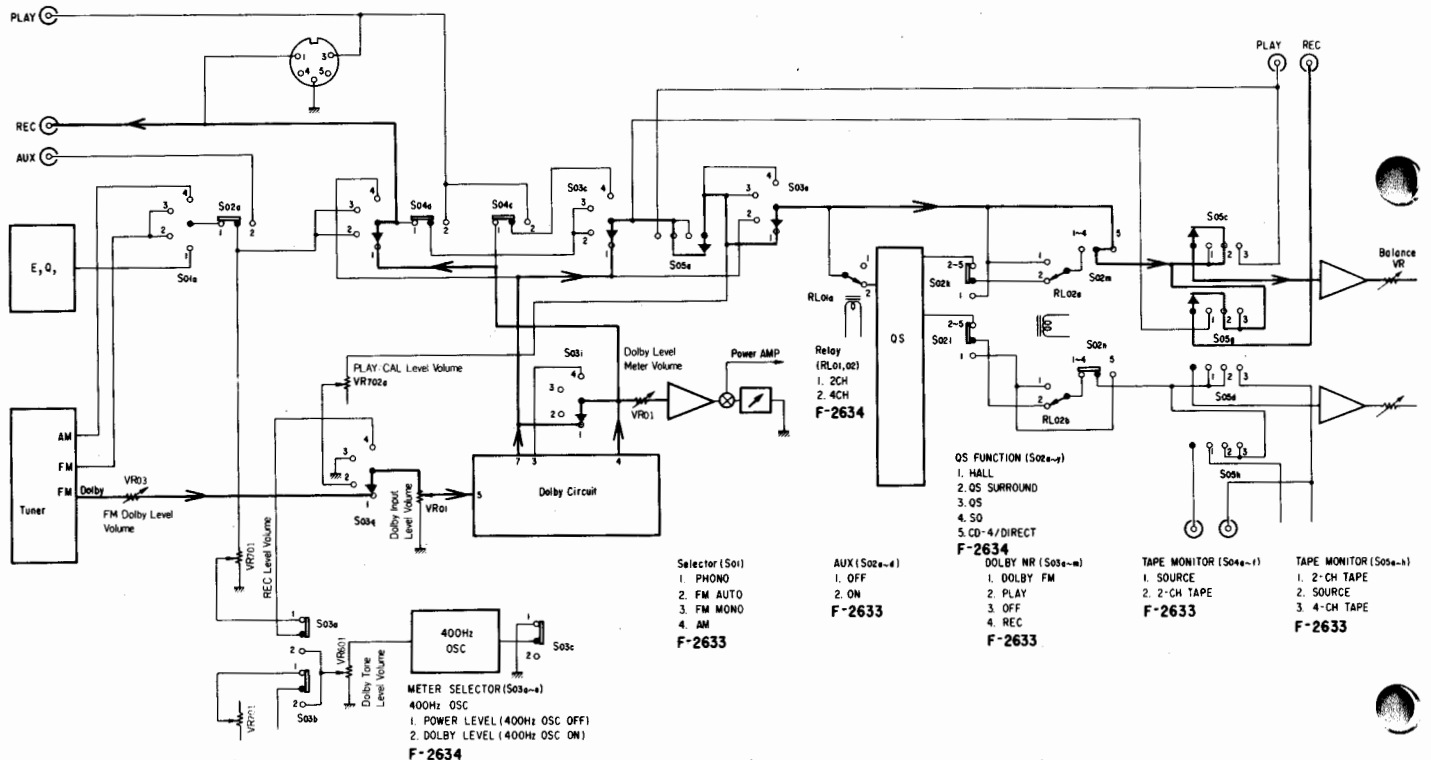

**[b] Dolby Operation (Rec Mode)**

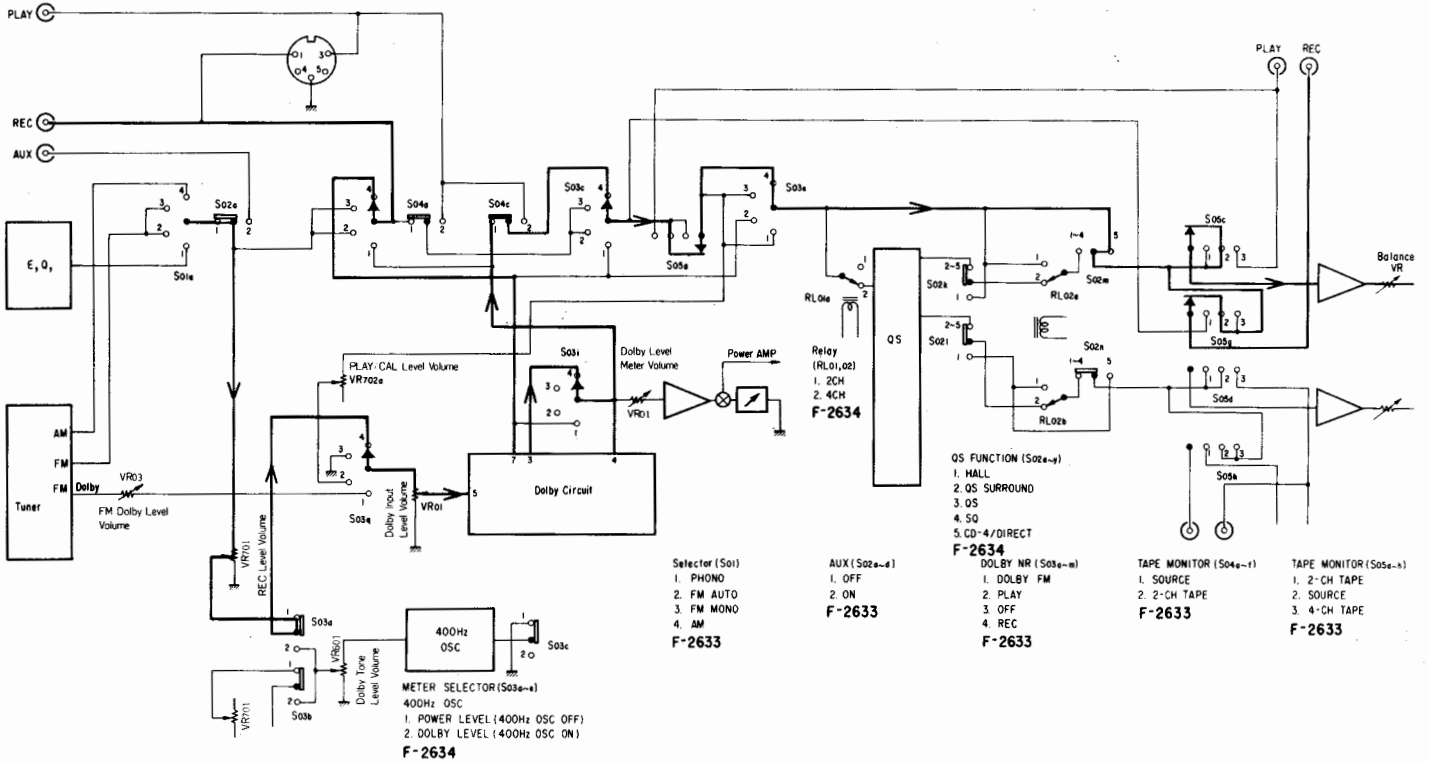

**[c] Dolby Operation (Play Mode)**

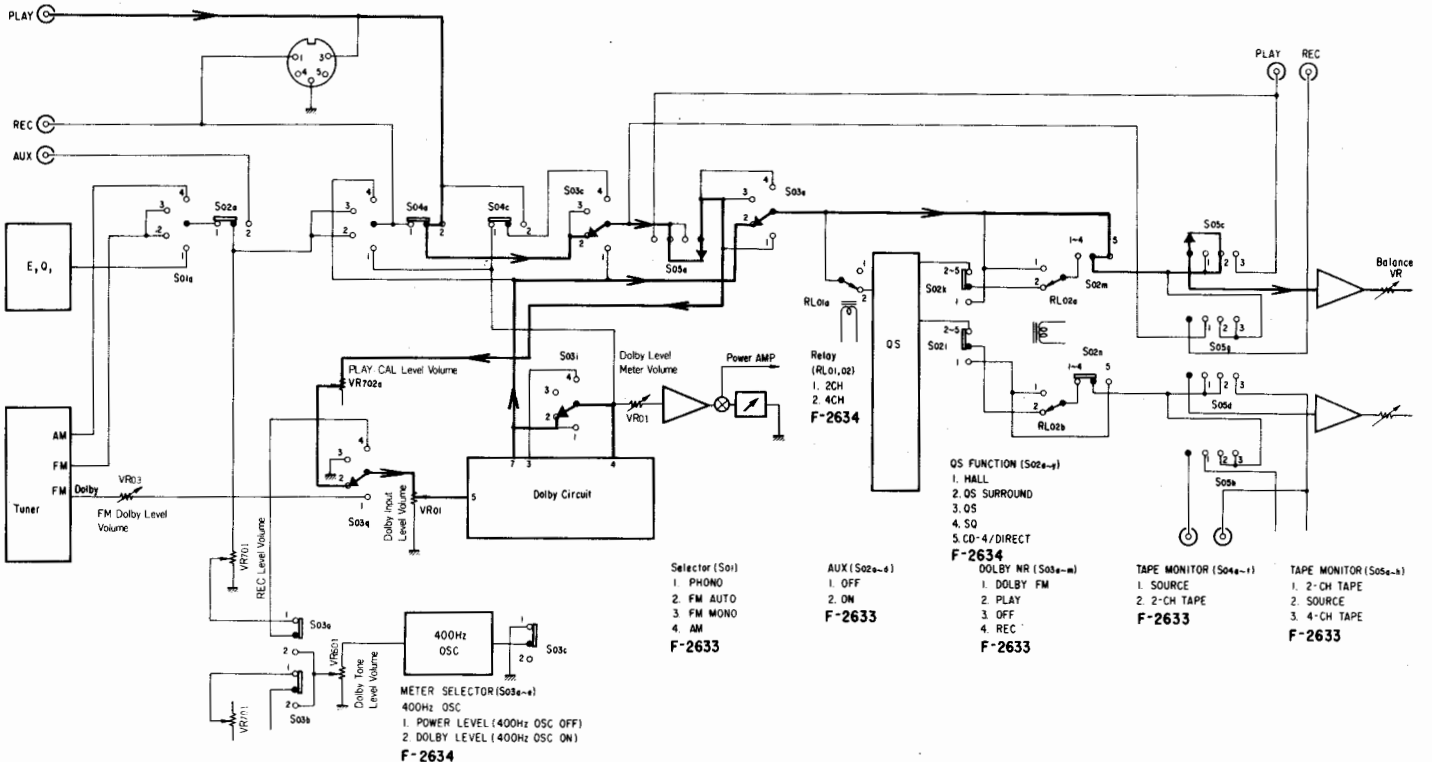

### 3. OPERATION OF FM DOLBY SYSTEM

This Dolby Noise Reduction System Type B used in this unit is not only available for encoding of the FM dolbyized signal but also useful for encoding and decoding of other signals. Therefore it is possible and effective to combine with other products such as a cassette deck without Dolby system.

#### FM Dolby System

FM broadcasting system is originally able to produce a very high quality audio performance; however, FM stereophonic broadcasting system incurs a 20dB Signal-Noise ratio decrease. When Dolby B Type Noise Reduction system is used for a FM stereo, Signal-Noise ratio (S/N) is conspicuously improved and this ratio is at about 10dB.

Fig. 3-1

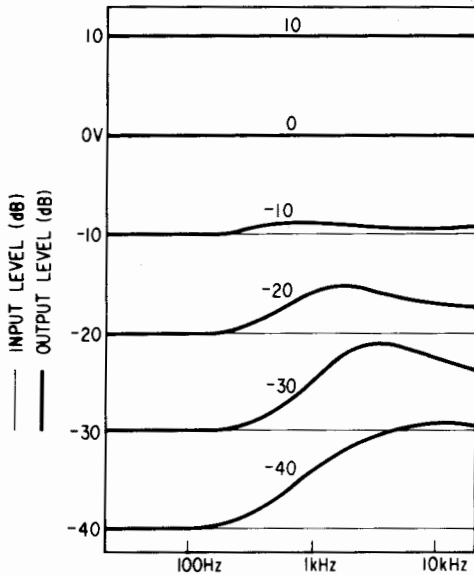

Whole range output Frequency Response characteristics against input level.

Fig. 3-2

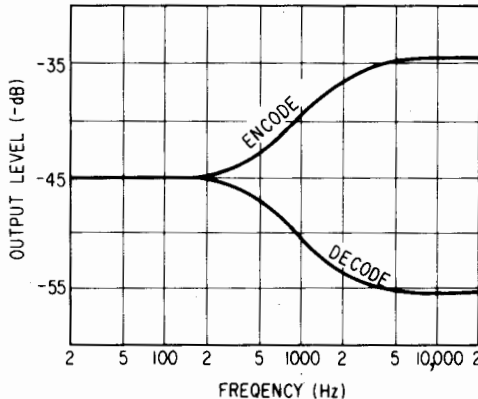

Low level Frequency Response characteristics of encode and decode processors.

#### Principles

The S/N of the FM becomes worse when the frequency is high and the level is low. Because of this reason, the middle and high range of the low level signal is expanded by a FM station. Then the signal will be compressed proportionally along the expanded level by a receiving side. (See Fig. 1, 2)

This unit employs a IC NE545B for a main Dolby circuit. The Operating diagram is shown in the Fig. 3.

#### Complementary items

1. When FM Dolby system is being used, the de-emphasis of FM-out is  $25\mu s$ .
2. The input level of FM Dolby is at 50% modulation and  $\pm 37.5kHz$ .
3. This unit has a own 400Hz Oscillator for Dolby Tone in order to adjust itself to the Dolby level.

Fig. 3-3

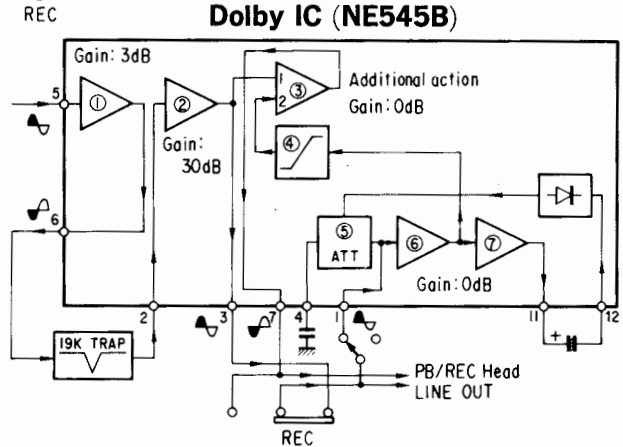

PLAY

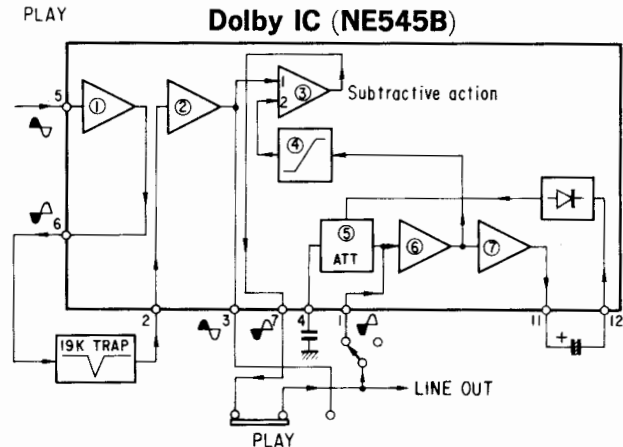

# 4. ADJUSTMENTS

## Abbreviations

### Equipment

AM FM Generator Oscilloscope ..... Genescope  
 AM Standard Signal Generator ..... AM SSG  
 FM Standard Signal Generator ..... FM SSG  
 FM Stereo Generator ..... Stereo SG  
 Oscilloscope ..... Scope  
 Audio Oscillator ..... Audio Osc.  
 Distortion Meter ..... Dist. Meter

### Others

Clockwise ..... CW.  
 Counterclockwise ..... CCW.  
 Antenna ..... ANT.  
 Modulation ..... MOD.

## 4-1. Audio Section

### 4-1-1. Driver Circuit Board Adjustment (See Figs. 4-1 & 4-2)

- Note:** 1. Master Volume ..... Minimum  
 2. Speaker Selector ..... SYSTEM (A)  
 3. Before adjustment, run the unit for more than 4 minutes, then check and readjust, if necessary.

STEP	SUBJECT	EQUIPMENT	MEASURE OUTPUT	ADJUST	ADJUST FOR	CONDITION
1	DC 0V Front L-CH	DC volt meter	Speaker terminal Front L-CH	F-2624 VR01	0V ±10mV	◦Step down meter's range accordingly ◦Change lead's polarity if meter swings backward
2	DC 0V Front R-CH	DC volt meter	Speaker terminal Front R-CH	F-2624 VR02	0V ±10mV	Same as above
3	DC 0V Back L-CH	DC volt meter	Speaker terminal Back L-CH	F-2624 VR01	0V ±10mV	Same as above
4	DC 0V Back R-CH	DC volt meter	Speaker terminal Back R-CH	F-2624 VR02	0V ±10mV	Same as above
5	Bias current Front L-CH	DC milliammeter	F-2638 F06	F-2624 VR03	30 ±3mA	Same as above
6	Bias current Front R-CH	DC milliammeter	F-2638 F07	F-2624 VR04	30 ±3mA	Same as above
7	Bias current Back L-CH	DC milliammeter	F-2638 F08	F-2624 VR03	30 ±3mA	Same as above
8	Bias current Back R-CH	DC milliammeter	F-2638 F09	F-2624 VR03	30 ±3mA	Same as above

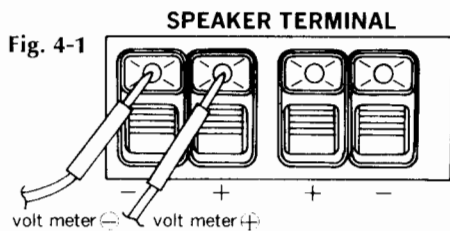

**Rear Side (Bottom View)**

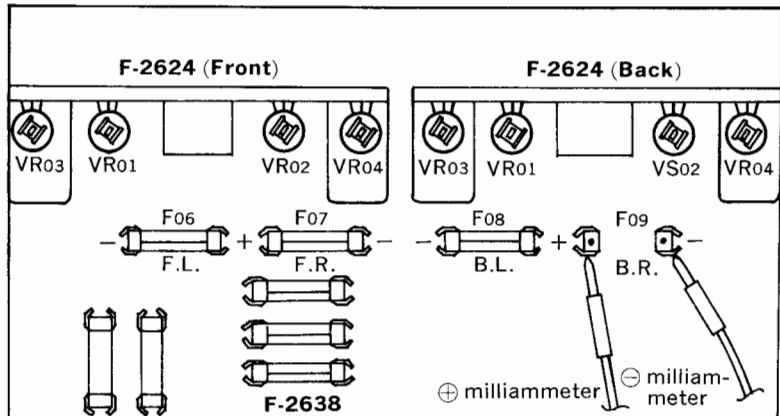

**Fig. 4-2**

### 4-1-2. Power Meter Adjustment (See Fig. 4-3)

- Note:**
1. Input .....AUX
  2. Input Signal .....Sine Wave (1kHz)
  3. Speaker load.....8Ω
  4. Master Volume .....Maximum
  5. CD-4/4-CH DIRECT Switch .....ON
  6. Dolby NR Switch .....OFF
  7. Speakers Switch .....4-CH A
  8. For adjustment, run the unit for more than 4 minutes after the power is switched ON.

STEP	EQUIPMENT	MEASURE OUTPUT	OUTPUT LEVEL	ADJUST	ADJUST FOR
Front L-CH	AC Volt Meter	Speaker Terminal Front L-CH	20V (50W)	VR01 F-2689	Meter Position 50W 
Front R-CH	Same as above	Speaker Terminal Front R-CH	Same as above	VR02 F-2689	
Back L-CH	Same as above	Speaker Terminal Back L-CH	Same as above	VR03 F-2689	
Back R-CH	Same as above	Speaker Terminal Back R-CH	Same as above	VR04 F-2689	

Fig. 4-3



Front Side (Bottom View)

## 4-2. Tuner Section

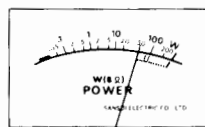
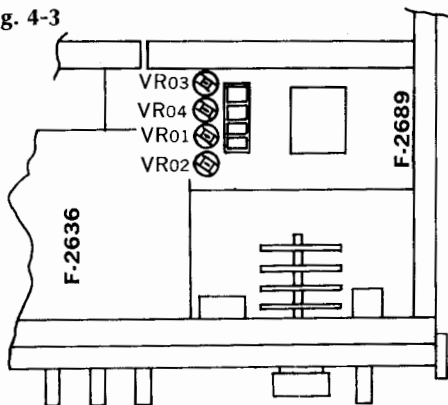

### 4-2-1. FM & MPX Adjustment & Alignment

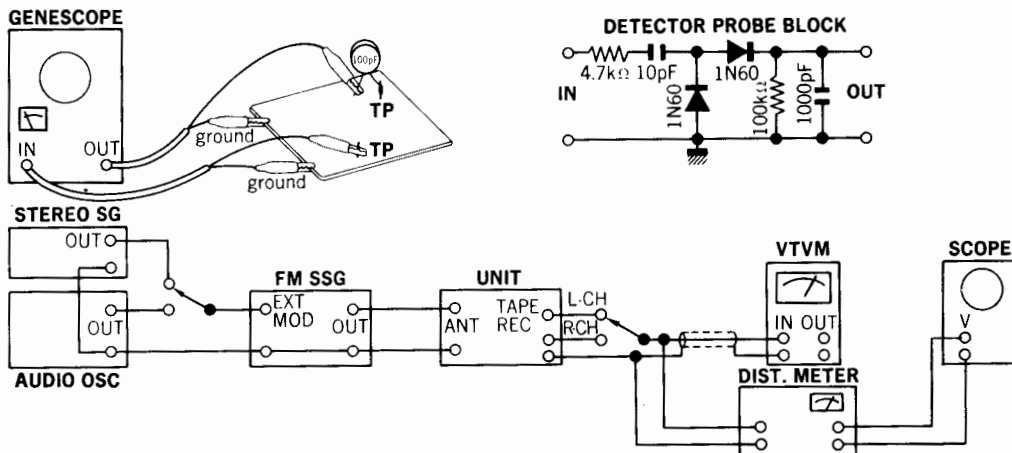
- Note:**
1. Selector.....FM AUTO
  2. FM Muting Switch.....OFF
  3. Connection.....Connect the output of genescope to TP through 100pF ceramic capacitor.



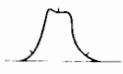
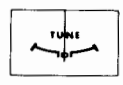
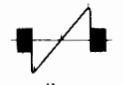

<QRX-8001> A) FM IF Adjustment & Tracking (See Fig. 4-4)

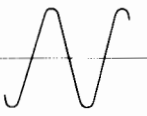
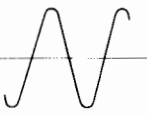
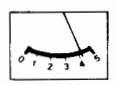
STEP	SUBJECT	FEED SIGNAL		MEASURE OUTPUT	ADJUST	ADJUST FOR	CONDITION
		FROM	TO				
1.	IF Coil	Output 60dB Genescope	TP01 F-2590	TP03 F-2590 Use Detector Probe	T01 F-2590	Max. IF waveform	
2.	Discriminator Coil	Output 50dB Genescope	Same as above	TP04 F-2590	T02       T03 F-2590	Center indication on tune meter  Max. linearity of S curve  Steep linearity of S curve  Set output wave to dip point (It's minimum distortion)	  
3.	90MHz Dial Calibration	90MHz ANT Input 60dB 400Hz (100% MOD) FM SSG	ANT terminal 300Ω	REC OUT L or R-CH VTVM & Scope	L03 F-2590	Max. Output	
	106MHz Dial Calibration	106MHz ANT Input 60dB 400Hz (100% MOD) FM SSG	Same as above	Same as above	TC03 F-2590	Same as above	
4.	90MHz RF Adj.	90MHz ANT Input 60dB 400Hz (100% MOD) FM SSG	Same as above	Same as above	L01, L02 F-2590	Same as above	
	106MHz RF Adj.	106MHz ANT Input 60dB 400Hz (100% MOD) FM SSG	Same as above	Same as above	TC01 TC02 F-2590	Same as above	
5.	Signal Meter Volume	98MHz ANT Input 60dB 400Hz (100% MOD) FM SSG	Same as above	Signal Meter	VR02 F-2590	4.3 on Meter	

◇ Adjusting or Connecting Points on AM, FM & FM MPX circuit board F-2590

Fig. 4-4

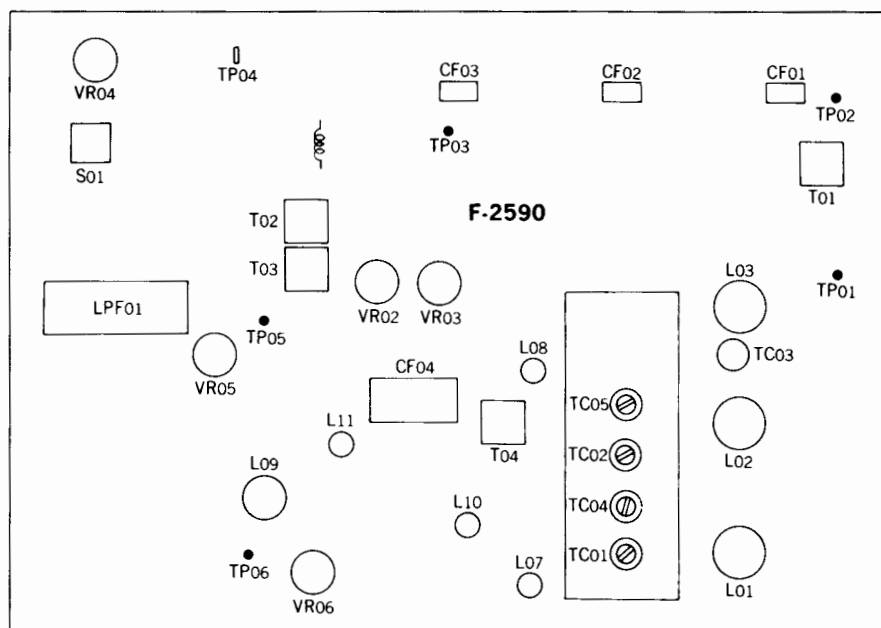

◁QRX-9001▷ B) FM IF Adjustment & Tracking (See Fig. 4-5)

STEP	SUBJECT	FEED SIGNAL		MEASURE OUTPUT	ADJUST	ADJUST FOR	CONDITION
		FROM	TO				
1.	IF Coil	Output 60dB Genescope	TP01 F-2614	TP03 F-2614 Use Detector Probe	T01 F-2614	Max. IF waveform	
		Output 50dB Genescope	Same as above	TP04 F-2614 Use Detector Probe	T02 F-2614		
2.	Discriminator Coil	Output 50dB Genescope	Same as above	TM04 F-2614	T03	Center indication on tune meter	
					T04 F-2614		
							Steep linearity of S curve
						Set output wave to dip point (It's minimum distortion)	
3.	90MHz Dial Calibration	90MHz ANT Input 60dB 400Hz (100% MOD) FM SSG	ANT terminal 300Ω	REC OUT L or R-CH VTVM & Scope	L05 F-2614	Max. Output	
	106MHz Dial Calibration	106MHz ANT Input 60dB 400Hz (100% MOD) FM SSG	Same as above	Same as above	TC01 F-2614		
4.	90MHz RF Adj.	90MHz ANT Input 60dB 400Hz (100% MOD) FM SSG	Same as above	Same as above	L01, L02, L03 F-2614	Same as above	
	106MHz RF Adj.	106MHz ANT Input 60dB 400Hz (100% MOD) FM SSG	Same as above	Same as above	VT01a VT01c VT01e F-2614	Same as above	
5.	Signal Meter Volume	98MHz ANT Input 100dB 400Hz (100% MOD) FM SSG	Same as above	Signal Meter	VR11 F-2615	4.7 on Meter	

◆Adjusting or Connecting Points on AM, FM & FM MPX circuit board F-2614

Fig. 4-5

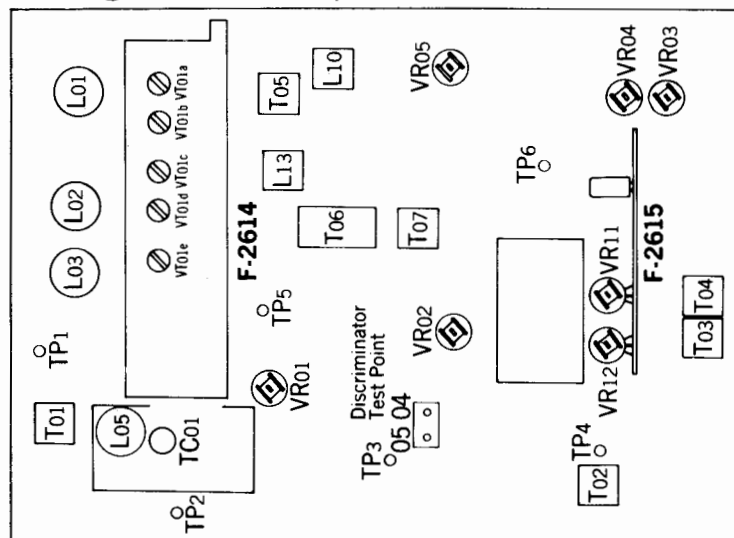

### 4-2-2. MPX Adjustment (See Fig. 4-4 & 4-5)

STEP	SUBJECT	FEED SIGNAL		MEASURE OUTPUT	ADJUST	ADJUST FOR	CONDITION
		FROM	TO				
1.	PLL VCO Adj.	98MHz ANT Input 60dB FM SSG Pilot 19kHz (10% MOD) L-CH 1kHz (45% MOD) R-CH (0% MOD) STEREO SG	ANT terminal 300Ω	Stereo indicator	(A)VR05 F-2590 (B)VR01 F-2614	Light indicator	Adjust the VR within center of lighting level.
	PLL VCO Adj. In case of using Freq. counter.		Make short between TP04 & chassis	TP05 (A)F-2590 (B)F-2614 Use Freq. counter	VR05 (A)F-2590 (B)F-2614	76kHz ±200Hz	For this adjustment, run the unit over 30 seconds.
2.	Separation	98MHz ANT Input 60dB FM SSG Pilot 19kHz (10% MOD) L-CH (0% MOD) R-CH 1kHz (45% MOD) STEREO SG	ANT terminal 300Ω	REC OUT L-CH VTVM & Scope	(A)VR04 F-2590 (B)VR02 F-2614	Min. Output -35dB	Confirm separation L-CH→R-CH -35dB
3.	Muting level & indicator level	98MHz ANT Input (A)18dB (B)23dB FM SSG Pilot 19kHz (10% MOD) L-CH 1kHz (45% MOD) R-CH (0% MOD) STEREO SG	Same as above	Stereo indicator	(A)VR03 F-2590 (B)VR12 F-2614	Muting level (A)18dB (B)23dB Indicator lighting level (A)18dB (B)23dB	

\* In the procedure above, (A) is indicating QRX-8001 and (B) is QRX-9001.

### 4-2-3. AM IF Adjustment & Tracking (See Fig. 4-4 & 4-5)

- Note: 1. Selector.....AM  
2. Confirm start point of dial pointer before alignment.

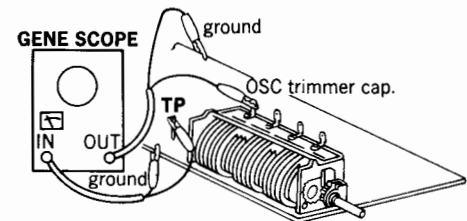
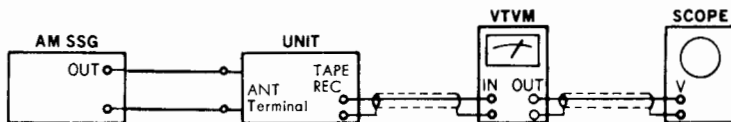

STEP	SUBJECT	FEED SIGNAL		MEASURE OUTPUT	ADJUST	ADJUST FOR	CONDITION
		FROM	TO				
1.	IF Coil	Genescope Output 65dB	(A)TC04 F-2590 (B)VT01b F-2614	TP06 (A)F-2590 (B)F-2614	(A)CF04 F-2590 (B)T06 F-2614	Max. IF waveform	
2.	600kHz Dial Calibration	600kHz ANT Input 60dB 400Hz (MOD 30%) AM SSG	AM ANT terminal	REC OUT L or R-CH VTVM & Scope	(A)T04 F-2590 (B)L13 F-2614	Max. Output	
	1400kHz Dial Calibration	1400kHz ANT Input 60dB 400Hz (MOD 30%) AM SSG	Same as above	Same as above	TC05 (A)F-2590 (B)F-2614	Same as above	

to be continued

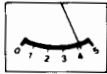
STEP	SUBJECT	FEED SIGNAL		MEASURE OUTPUT	ADJUST	ADJUST FOR	CONDITION
		FROM	TO				
3.	600kHz RF Adj.	600kHz ANT Input 60dB 400Hz (MOD 30%) AM SSG	AM ANT Terminal	REC OUT L or R-CH VTVM & scope	L702 Bar Antenna	Same as above	
	1400kHz RF Adj.	1400kHz ANT Input 60dB 400Hz (MOD 30%) AM SSG	Same as above	Same as above	(A)TC04 F-2590 (B)VT01b F-2614	Same as above	
4.	Signal Meter volume	1000kHz ANT Input 76dB 400Hz (MOD 30%) AM SSG	Same as above	Signal Meter	(A)VR06 F-2590 (B)VR05 F-2614	(A)4.3 on meter (B)4 on meter	

\* In the procedure above, (A) is indicating QRX-8001 and (B) is QRX-9001.

### 4-3. Dolby Circuit Adjustment (QRX-9001 Only) (See Fig. 4-6)

#### 4-3-1. Input Level Adjustment of Dolby IC (NE545B)

- Note:
- |                                 |                                   |
|---------------------------------|-----------------------------------|
| 1. Speaker Selector .....2-CH A | 4. Accessory Switch .....OFF      |
| 2. Master Volume .....Minimam   | 5. REC Level Volume .....MAX      |
| 3. Balance Volume .....Center   | 6. Dolby Selector Switch .....REC |

STEP	SUBJECT	FEED SIGNAL		MEASURE OUTPUT	ADJUST	ADJUST FOR
		FROM	TO			
1.	L-CH	400Hz 85mV Audio OSC.	AUX Terminal	REC Terminal TAPE 1 VTVM	VR01 F-2688	Output 270mV
2.	R-CH	Same as above	AUX Terminal	REC Terminal TAPE 1 VTVM	VR02 F-2688	Same as above

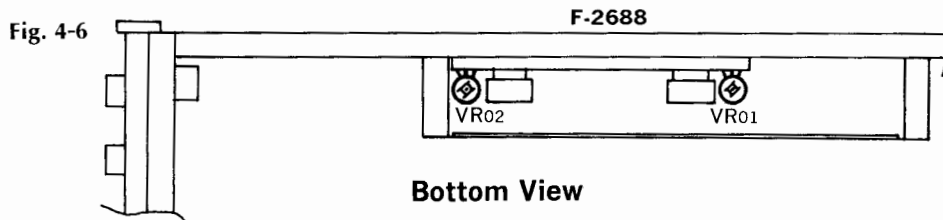

Bottom View

#### 4-3-2. Calibration Tone Volume & Dolby Meter Volume Adjustment

- Note:
- |                                 |                                   |
|---------------------------------|-----------------------------------|
| 1. Speaker Selector .....2-CH A | 4. Accessory Switch .....OFF      |
| 2. Master Volume .....Minimam   | 5. Dolby Selector Switch .....REC |
| 3. Balance Volume .....Center   |                                   |

##### (1) Calibration Tone Volume Adjustment (See Fig. 4-7 on Page 12)

1. Turn on the Dolby REC CAL. TONE switch.
2. Connect VTVM to the front TAPE 1 REC terminal.
3. Adjust VR601 on the circuit board, F-2634 to obtain 270mV on indication of VTVM.

(2) Dolby Meter Volume Adjustment (See Fig. 4-8, 4-9)

Adjust VR01 (L-CH) and VR02 (R-CH) on the circuit board, F-2633 so that indicator of power meter will be center of Dolby mark.

Fig. 4-7

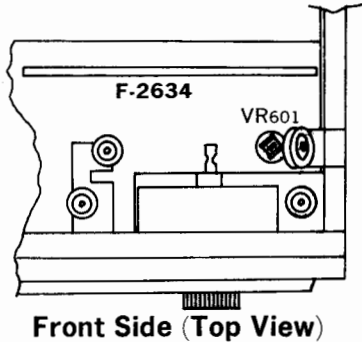

Front Side (Top View)

Fig. 4-9

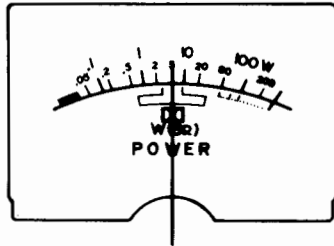
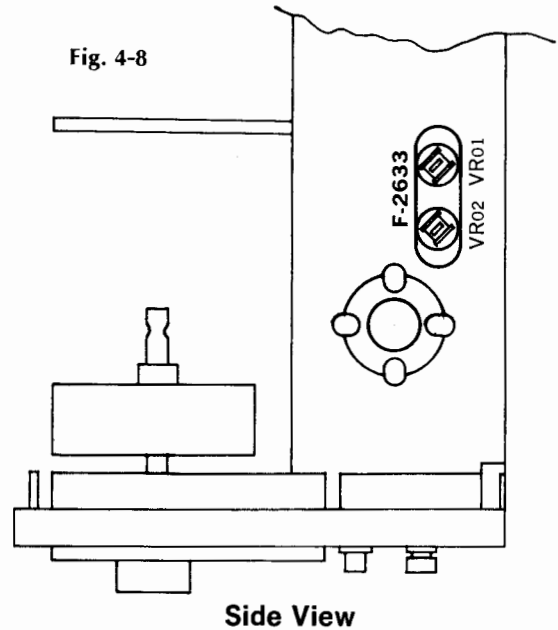

Fig. 4-8



Side View

4-3-3. FM Dolby Volume Adjustment (See Fig. 4-10)

- Note: 1. Selector.....FM  
 2. Dolby Selector .....Dolby FM  
 3. REC CAL. TONE Switch.....OFF  
 4. Master Volume .....Min.

SUBJECT	FEED SIGNAL		MEASURE OUTPUT	ADJUST	ADJUST FOR
	FROM	TO			
L-CH	98MHz ANT Input 60dB FM SSG Pilot 19kHz (10% MOD) L-CH 1kHz (25% MOD) R-CH (0% MOD)	FM ANT Terminal 300Ω	REC Terminal TAPE 1 L-CH VTVM	VR03 F-2614	Output Level 270mV
R-CH	98MHz ANT Input 60dB FM SSG Pilot 19kHz (10% MOD) R-CH 1kHz (25% MOD) L-CH (0% MOD)	Same as above	REC Terminal TAPE 1 R-CH VTVM	VR04 F-2614	Same as above

Fig. 4-10

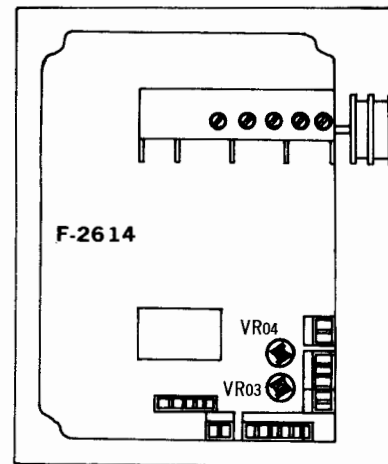

Front Side (Top View)

# 5. PARTS LOCATION & PARTS LISTS

## 5-1. F-2636 Volume & Filter Circuit Board

Conductor Side (Stock No. 7594311 MODEL QRX-9001) (Stock No. 7564381 MODEL QRX-8001)

Since some of capacitors and resistors are omitted from parts lists in this Service Manual, refer to the common parts list for capacitors & resistors which was appended previously to each Sansui Manual.

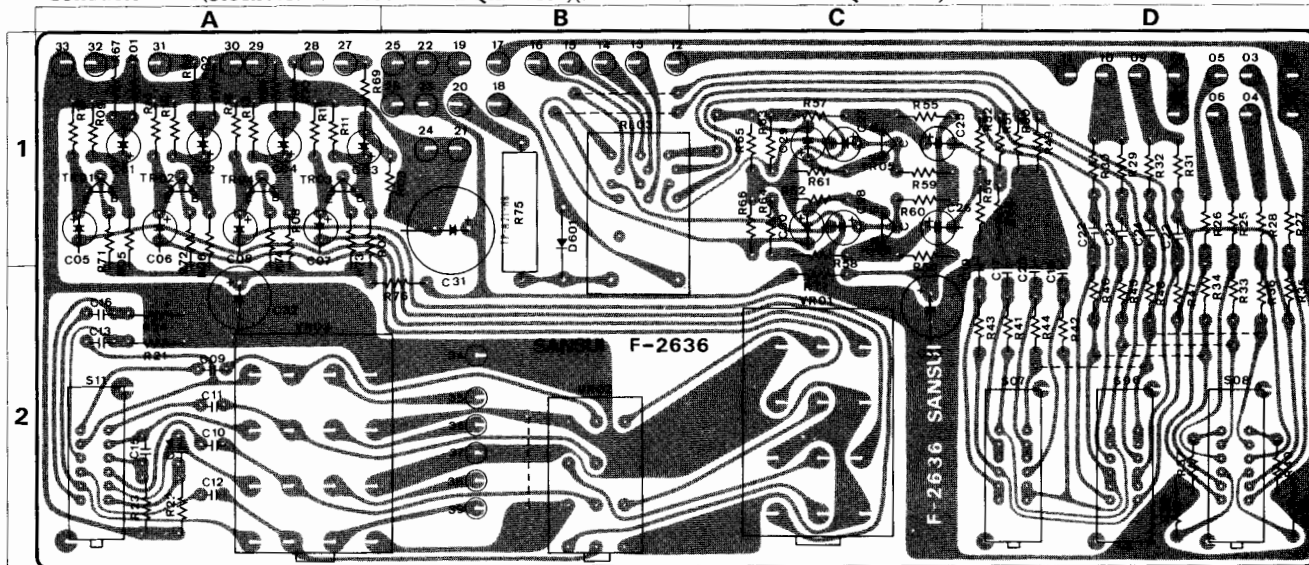

### Parts List

Parts No.	Stock No.	Description	Position	Parts No.	Stock No.	Description	Position	Parts No.	Stock No.	Description	Position
TR01-04	0306070	2SC1313 (F, G)	1 A	VR01	1060380, 1	250kΩ × 4 (M, N)	Volume	S03-04	1170880	SLS14251 A	Lever Switch
TR05, 06	0306070, 1	2SC1313 (F, G)		1 C	VR02	1065030, 1		250kΩ × 4 (M, N)	2 B	<b>MODEL QRX-9001 Only</b>	
D601	0310340	10D1 Diode	1, 2 B	VR03	1060450, 1	250kΩ × 4 (B)		2 A	S05	1170880	
C09-12	0620161	160pF 50V P.C.		<b>MODEL QRX-8001 Only</b>				S06, 07	1170880	Lever Switch	2 D
R75	0182561	560Ω 2W Ce.R.	1, 2 B	S01	1170880	SLS14251 A	Lever Switch	S08	1170870		
RL01	1150380	MH4P-0 Relay		S02	1170870	SLS14201 A					

## 5-2. F-2634 4-ch Function Switch & REC CAL Tone Circuit Board

Conductor Side (Stock No. 7650501 MODEL QRX-9001) (Stock No. 7650551 MODEL QRX-8001)

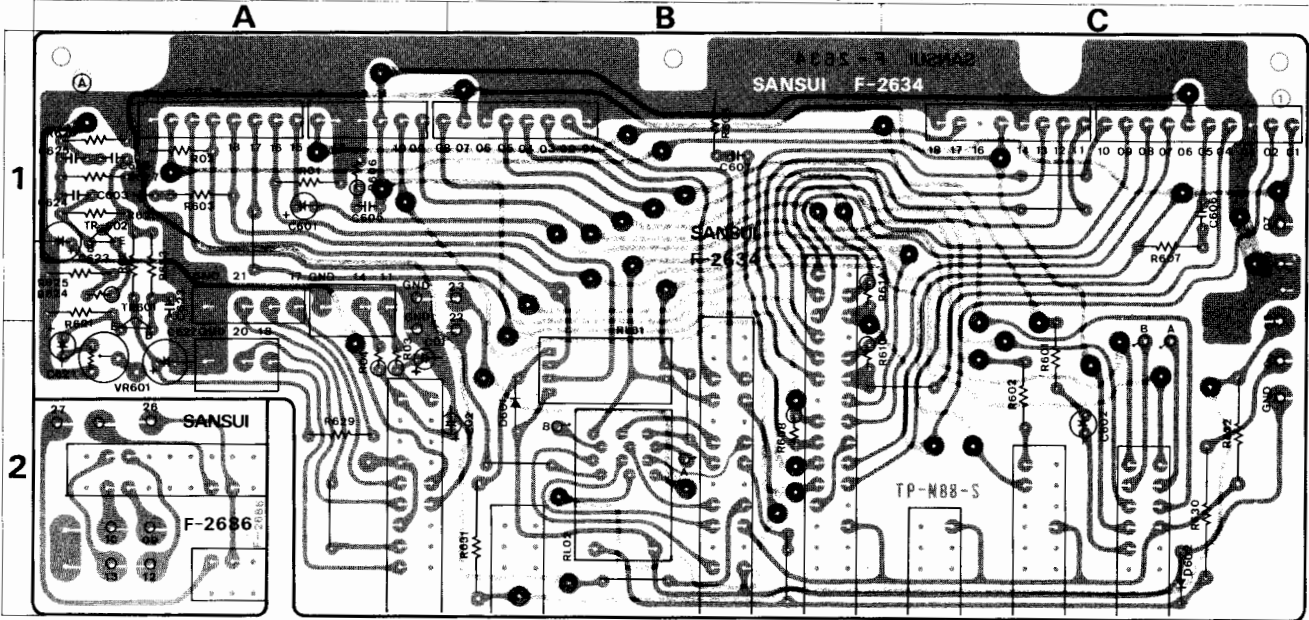

### Parts List

Part No.	Stock No.	Description	Position	Parts No.	Stock No.	Description	Position	Parts No.	Stock No.	Description	Position
D601	0310340	10D-1 Diode	2 B	S02	1131350	Push Switch, AUDIO MUTING		<b>MODEL QRX-9001 Only</b>			
ZD901	0315970	EQ801-13R Zener Diode		2410590	4P Pin Ass'y (Type D)		TR001	0306131, 2	25C1364 (6, 7)	Transistor	1, 2 A
R630	0182821	820Ω 2W Ce.R.	2 C	2410730	6P Pin Ass'y (Type A)		TR002	0306131, 2	25C1364 (6, 7)		1 A
RL01	1150320	HA-224N Relay	2 B	2410740	8P Pin Ass'y (Type A)		D602	0310340	10D-1 Diode	2 C	
RL02	1150380	MH4P-0 Relay	2 B	2410750	10P Pin Ass'y (Type A)		VR01	1035190	100kΩ(B)	2 A	
				<b>MODEL QRX-8001 Only</b>							
				S09	1131340	Push Switch					
							S03	1131340	Push Switch, LOW FILTER		
							2410920	3P Pin Ass'y (Type E)			

### 5-3. F-2638 Power Supply Circuit Board

(Stock No. 7502031 MODEL QRX-9001)  
(Stock No. 7502051 MODEL QRX-8001)

Conductor Side

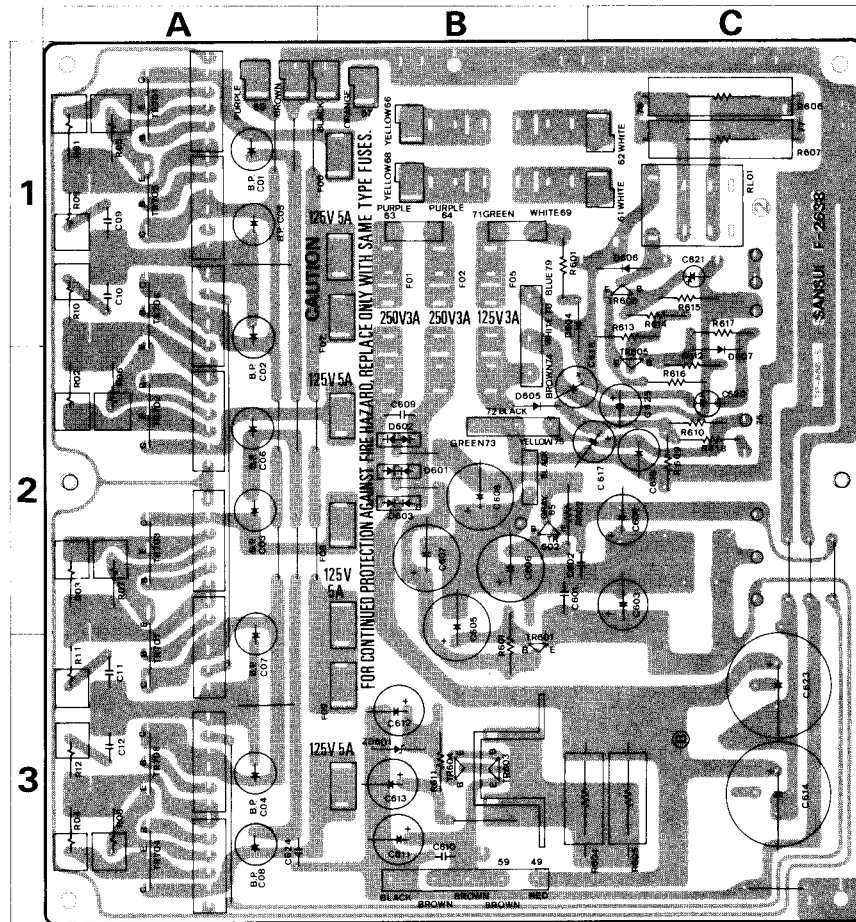

#### Parts List

Parts No.	Stock No.	Description	Position
TR01	0308451	2SD356 (D)	Transistor 3 B
	0308452	2SD356 (E)	
	0303360	2SB560 (D)	
TR02	0303361	2SB560 (E)	Transistor 2 B
	0308391.2	2SD313 (D, E)	
TR03	0305930.1	2SC1211 (C, D)	3 B
D01	0310680	10DC-1 (Black)	2 B
D02	0310670	10DC-1R (RED)	2 B
D03	0310680	10DC-1 (Black)	2 B
D04	0310340	10D-1 (1S2226)	Diode 1.2 B
ZD01	0315970	EQA01-13R	3 B
	0316310	RD-13E (B)	
C01	0655103	10000pf	2 B
C02	0655103	10000pf	500V C.C. 2 B
C09	0655103	10000pf	2 B
C04	0549207	1000pf	63V E.C. 3 C
C23	0549207	1000pf	3 C
R01-04	0153338	0.33Ω	3 W Ce.R. 1.2, 3 A
R05-08	0153338	0.33Ω	1.2, 3 A
R09-12	0156479	4.75Ω	20W Ce.R. 1, 3 A
R04	0183471	470Ω	3 B, C
R05	0183471	470Ω	3 C
F01, 02	0432260	3A, 250V	1 B
F03, 04	0434060	10A, 250V	AC Fuse 1 B
F05	0432260	3A, 250V	
F06-09	0432290	5A, 125V	1 B, 3 B
	2310220	Fuse Holder (large)	
	2310230	Fuse Holder (Small)	
	5936990	Heat Sink	
	2410730	6P Pin Assy Type A	
<b>MODEL QRX-8001 Only</b>			
R08	0192479	4.75Ω 1/2W F.R.	
F03, 04	0434060	10A, 250V AC Fuse	
<b>MODEL QRX-9001 Only</b>			
TR05	0306131.2	2SC1364 (6, 7)	Transistor 2 C
TR06	0306131.2	2SC1364 (6, 7)	1 C
D05	0310340	10D-1	2 B
D06	0310340	10D-1	1 C
D07	0310340	10D-1	2 C
R06, 607	0137399	3.91Ω 7 W Ce.R.	1 C
R08	0192479	4.75Ω 1/2 W F.R.	
RL01	1150360	Relay	

### 5-4. F-2637 Tone Control Circuit Board

(Stock No. 7561561 MODEL QRX-9001)  
(Stock No. 7561571 MODEL QRX-8001)

Conductor Side

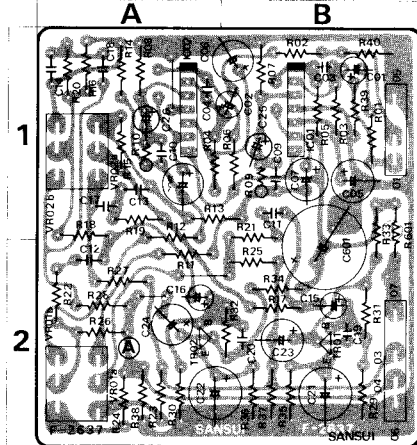

#### Parts List

Parts No.	Stock No.	Description	Position
TR01, 02	0306070.1	2SC1313 (F, G)	Transistor 2 B, 2 A
IC01, 02	0360190	BA312 I.C.	1 B, 1 A
VR01	1015200.1	100kΩ (B)	2 A
VR02	1015200.1	100kΩ (B)	1 A
	2410670	3P Pin Assy (Type F)	
	2410680	4P Pin Assy (Type F)	

**NOTE:** A part of the words printed on the circuit board, F-2638, is different from the Fig above and the schematic diagram because of productive term difference. In case of above, please refer to the Fig above and the schematic diagram.

(Different point)

The words TR702, TR704, TR706 and TR708 are misprinted as follows.

TR702→TR708 TR704→TR706 TR706→TR704 TR708→TR702

(Applicable model)

The left-most digit of serial NO. 23609, 23610 and 23611.

### 5-5. F-2639 Pre-Power Supply Circuit Board

(Stock No. 7502041 MODEL QRX-9001) (Stock No. 7502061 MODEL QRX-8001)

Conductor Side

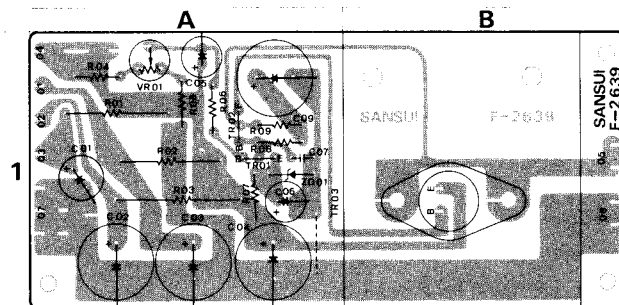

#### Parts List

Parts No.	Stock No.	Description	Position
TR01	0306070.1	2SC1313 (F, G)	1 A
TR02	0305930.1	2SC1211 (C, D)	1 A
TR03	0306100.1	2SC1444 (R, O)	Transistor 1 A
	0308551.2	2SD315V10(D, E)	
ZD01	0315760	EQA01-06R	Zener Diode 1 A
	0316390	RD6.2E	
	0316390	RD6.2E	

Parts No.	Stock No.	Description	Position
R02	0133181	180Ω	1 A
R03	0133181	180Ω	3 W Ce.R. 1 A
VR01	1035350	4.7kΩ (B)	Semi-Variable Resistor 1 A
	5937420	Heat Sink	
<b>MODEL QRX-8001 Only</b>			
R01	0182331	330Ω	2 W Ce.R. 1 A

### 5-6. F-2614 Tuner Circuit Board (Stock No. 7521361 MODEL QRX-9001 Only)

Conductor Side

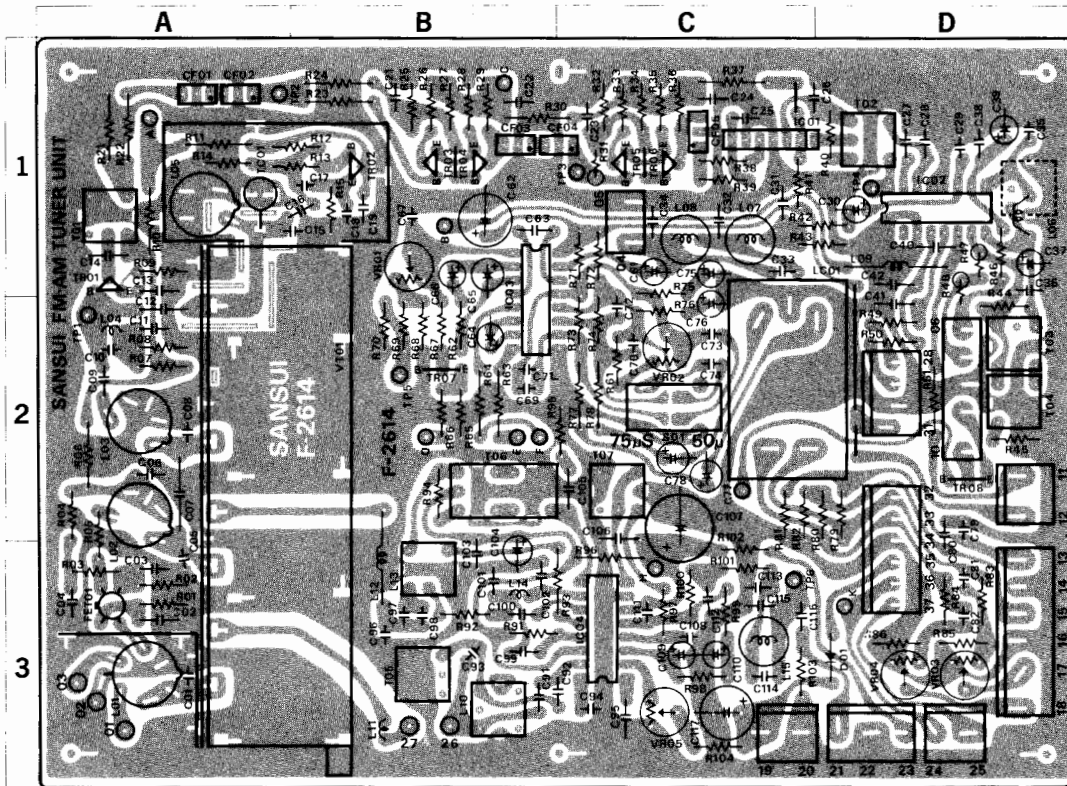

#### Parts List

Parts No.	Stock No.	Description	Position	Parts No.	Stock No.	Description	Position
TR01	0305801, 2	2SC1047 (B, C)	1 A	L02	4210340	3-307395 RF Coil	2 A
TR02	0305801, 2	2SC1047 (B, C)	1 B	L03	4210340	3-307395 RF Coil	2 A
TR03	0306341	2SC1674 (L)	1 B	L04	4900140	L-140 1/2F Inductor	2 A
	or	or		L05	4220400	3-304672 Osc Coil	1 A
	0306342	2SC1674 (K)		L06	4290300	18mH Inductor	1 D
	0306341	2SC1674 (L)		L07	4900250	8.2rH Inductor	1 C
TR04	0306342	2SC1674 (K)	1 B	L08	4900240	6.8rH Inductor	1 C
	0306341	2SC1674 (L)		L09	4290011	Peaking Coil	1 D
TR05	0306342	2SC1674 (K)	Transistor	L11	4900100	L-0105 3.3rH Inductor	3 B
	0306342	2SC1674 (L)		L12	4290011	Peaking Coil	2, 3 B
	0306341	2SC1674 (L)		L13	4220650	138rH Osc Coil	3 B
TR06	0306341	2SC1674 (L)	1 C	L14	4900110	100rH Inductor	3 B
	0306342	2SC1674 (K)		L601	4900100	3.3rH Inductor	
	0305731, 2	2SC711 (E, F)		T01	4235930	10.7MHz IF Coil	1 A
TR07	0305951, 2	2SC945 (Q, P)	2 B	T02	4235930	10.7MHz IC Coil	1 D
	or	or			4235990	10.7MHz FM IFT	
IC01	0360120	μPC555H	1 C	T03	or	or	2 D
IC02	0360350	HA1137	1 D		4235991	10.7MHz FM IF Coil	
IC03	0360320	HA1196	1, 2 B		4236000	10.7MHz FM IF Coil	
IC04	0360390	HA1197	3 C	T04	or	or	2 D
					4236001	10.7MHz FM IF Coil	
FT01	0370121, 2	3SK41 (L, M) FET	3 A	T06	0910280	455kHz Ceramic Filter	2 B
	0311160	1S2473D		T07	4230620	455kHz IF Coil	2 C
D02	or	or		CF01	0910150	10.7MHz	1 A
	0311180	1S1588		CF02	0910150	10.7MHz	1 A
	0311160	1S24730		CF03	0910150	10.7MHz	1 B
D903	or	or		CF04	0910150	10.7MHz	1 B, C
	0311180	1S1588		CF05	0910150	10.7MHz	1 C
C01	0669325	15pF	3 A	LC01	0910360	BL-12AK Low Pass Filter	2 C, D
C05	0669325	15pF	3 A	VR01	1034250	4.7kΩ (B)	1 B
C08	0669325	15pF	50V C.C.	VR02	1035190	100kΩ (B)	2 C
C09	0661100	10pF		VR03	1035130	10kΩ (B)	3 D
C12	0679008	1.0pF	500V Gimmick	VR04	1035130	10kΩ (B)	3 D
			Capacitor	VR05	1035110	4.7kΩ (B)	3 C
C15	0669330	20pF	1 A, B	S01	1110270	Slide Switch	2 C
C16	0669295	10pF	1 A, B	VT01	1220260	AM-FM Variable Capacitor	2, 3 A B
C17	0669295	10pF	1 B	TC01	1230090	Trimmer Capacitor	1 A
C18	0669295	10pF	50V C.C.		2260010	Test Pin	
C19	0669295	10pF	1 B		2260020	Test Pin	
C29	0661330	33pF			2410570	5P Pin Ass'y (Type F)	
C35	0669204	3.3pF	1 D		2410650	2P Pin Ass'y (Type F)	
C67	0629005	360pF	1 B		2410850	4P Pin Ass'y (Type B)	
C73	0620561	560pF	50V P.C.		2410860	6P Pin Ass'y (Type B)	
C74	0620561	560pF	2 C		2410910	2P Pin Ass'y (Type E)	
C96	0669400	15pF	3 B		2410920	3P Pin Ass'y (Type E)	
C97	0669400	15pF	50V C.C.		2410950	6P Pin Ass'y (Type E)	
C98	0620361	360pF	50V P.C.		2510040	Front End Pack	
R63	0210471	470Ω	1/2W N.I.R.				
L01	4200720	3-307393	Antenna Coil				

### 5-7. F-2615 Tuner Sub Circuit Board

(Stock No. 7521371 MODEL QRX-9001 Only)

Conductor Side

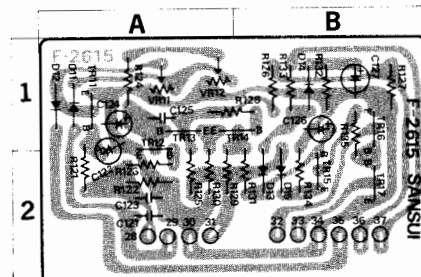

#### Parts List

Parts No.	Stock No.	Description	Position
TR11	0306390, 1	2SC1636(1, 2) or	1 A
	0305370, 1	2SC733 (O, Y)	
TR12	0305731, 2	2SC711 (E, F) or	1, 2 A
	0305951, 2	2SC945 (Q, P)	
TR13	0305731, 2	2SC711 (E, F) or	Transistor
	0305951, 2	2SC945 (Q, P)	
TR14	0305731, 2	2SC711 (E, F) or	1 A, B
	0305951, 2	2SC945 (Q, P)	
TR15	0300510, 1	2SA733 (P, Q)	2 B
TR16, 17	0306390	2SC1636 (1)	1 B, 2 B
	0305370, 1	2SC733 (O, Y)	
D11	0311160	1S2473D or	1 A
	0311180	1S1588	
D12	0311160	1S2473D or	1 A
	0311180	1S1588	
D13	0311160	1S2473D or	2 B
	0311180	1S1588	
D14	0311160	1S2473D or	1 B
	0311180	1S1588	
D15	0311160	1S2473D or	2 B
	0311180	1S1588	
D901	0311160	1S2473D or	Diode
	0311180	1S1588	
VR11	1035410	47kΩ (B)	1 A
VR12	1035430	100kΩ (B)	1 A
	2420510	4P Connector (Type A)	
	2420520	6P Connector (Type A)	



### 5-8. F-2590 Tuner Circuit Board (Stock No. 7521381 MODEL QRX-8001 Only)

Conductor Side

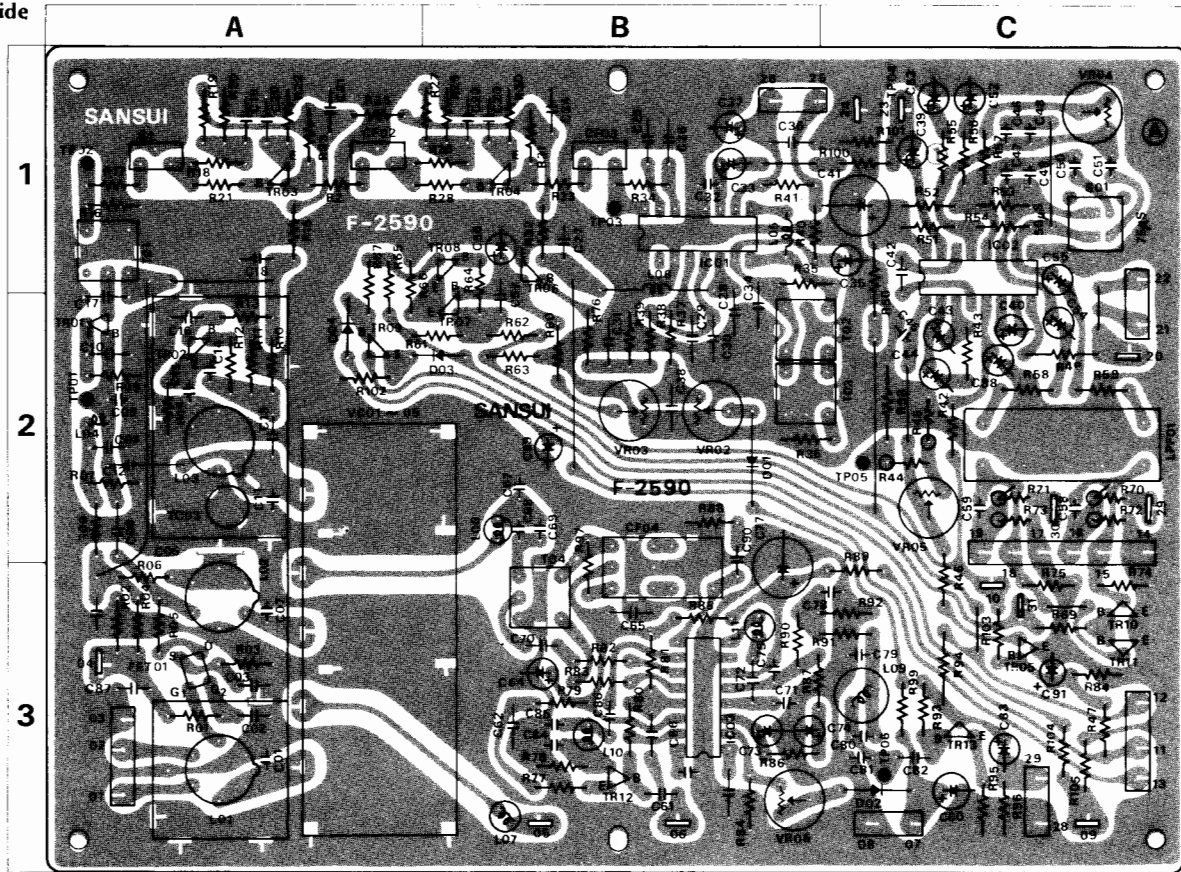

#### Parts List

Parts No.	Stock No.	Description	Position	Parts No.	Stock No.	Description	Position	Parts No.	Stock No.	Description	Position	
TR01	0305801	2SC1047 (B)	2A	D905	0311160	1S2473D	Diode	L07	4900100	3.3 $\mu$ H	3B	
TR02	0305801	2SC1047 (B)	2A		0311180	1S2473D		L08	4900100	3.3 $\mu$ H	2B	
TR03	0306113	2SC738 (D)	1A		0311160	1S2473D		L09	4900220	100mH	3C	
TR04	0306112	2SC738 (C)	1B	0311180	1S1588	L10	4900110	100 $\mu$ H	3B			
TR05	0305731, 2	2SC711 (E, F)	3C	C01	0669350	15pF	3A	L11	4900110	100 $\mu$ H	3B	
	0305731	2SC711 (E)	1B	C05	0659015	2200pF	2A	T01	4235930	10.7MHz	1A	
0305732	2SC711 (F)	C06		0669005	8.2pF	50V C.C.	2A	T02	4235990	10.7MHz	2B, C	
TR06	0305731	2SC711 (E)	2B	C07	0669350	15pF	3A	T03	4235991	10.7MHz	2B, C	
	0305732	2SC711 (F)		C09	0661220	22pF	2A		4236000	10.7MHz		
TR07	0305731	2SC711 (E)	2B	C11	0669355	20pF	2A	T04	4236001	10.7MHz	2B, C	
	0305732	2SC711 (F)		C12	0679012	1.5pF	500V Gimmick Capacitor		2A	4220650		138 $\mu$ H
TR08	0305731	2SC711 (E)	1B	C13	0661100	10pF	2A	CF01	0910150	10.7MHz	1A	
	0305732	2SC711 (F)		C14	0661100	10pF	50V C.C.	2A	CF02	0910150	10.7MHz	1A
TR09	0300470	2SA726 $\oplus$ (F)	2A	C15	0661100	10pF	2A	CF03	0910150	10.7MHz	1B	
TR10	0306390	2SC1636-1	3C	C45	0629005	360pF	2C	CF04	0910280	455kHz	2, 3B	
TR11	0306390	2SC1636-1	3C	C48	0620101	100pF	1C	LF01	0910220	19kHz	Low Pass Filter	
TR12	0300283	2SA628 (F)	3B	C49	0620101	100pF	50V P.C.	1C	VR02	1035170	47k $\Omega$ (B)	2B
TR13	0305731, 2	2SC711 (E, F)	3C	C50	0620561	560pF	1C	VR03	1035190	100k $\Omega$ (B)	2B	
IC01	0360350	HA1137	1B	C51	0620561	560pF	1C	VR04	1035210	220k $\Omega$ (B)	Semi-Variable Resistor	1C
	0360320	HA1196	1C	C67	0669400	15pF	50V C.C.	2B	VR05	1034250	4.7k $\Omega$ (B)	2C
IC03	0360150	HA1151	3B	C68	0661150	15pF	2B	VR06	1035110	4.7k $\Omega$ (B)	2C	
	0370131	3SK41 (L)	FET	C69	0620361	360pF	50V P.C.	2B	S01	1110270	Slide Switch	
0370132	3SK41 (K)	C84		0661150	15pF	50V C.C.		VC01	1220250	AM-FM Variable Capacitor	2A	
0370133	3SK41 (J)	C85		0661150	15pF	50V C.C.		TC03	1230090	Trimmer Capacitor		
D01	0340120	VD1212	Varistor	L01	4200720	Antenna Coil	3A		2410600	6P Pin Ass'y (Type D)		
D02	0310330, 1	1N60	2B	L02	4210340	RF Coil	3A		2410910	2P Pin Ass'y (Type E)		
D03	0311160	1S2473D	2B	L03	4220400	Osc. Coil	2A		2410920	3P Pin Ass'y (Type E)		
D04	0311160	1S2473D	2A	L04	4290110	Choke Coil	2A					
D901	0311160	1S2473D	2A	L05	4290280	18mH Inductor	1B					
D902	0311160	1S2473D	2A	L06	4290011	Peaking Coil	1B					

5-9. F  
Conductor

Parts List  
Parts No. Stock No.

TR01, 02	0305801
TR03, 04	0306113
TR05, 06	0305731, 2

5-10. F  
Conductor



5-11. F  
Conductor



## 5-9. F-2624 Driver Circuit Board (Stock No. 7571471 MODEL QRX-9001) (Stock No. 7571481 MODEL QRX-8001)

Conductor Side

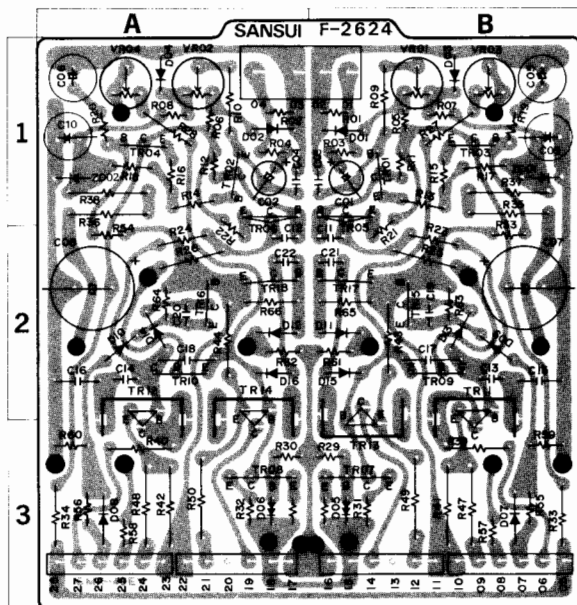

Parts No.	Stock No.	Description	Position
TR15, 16	0305951	2SC945 (Q)	Transistor
	or	or	
	0305952	2SC945 (P)	
TR17, 18	0300510	2SA733 (P)	2 B. 2 A
	0300511	2SA633 (Q)	
D01, 02	0311160	1S2473D	1, 2 B. 1 A
	or	or	
D03, 04	0311180	1S1588	1 B. 1 A
	or	or	
D05, 06	0311160	1S2473D	3 B. 3 A
	or	or	
D07, 08	0311180	1S1588	3 B. 3 A
	or	or	
D09, 10	0311160	1S2473D	2 B. 2 A
	or	or	
D11, 12	0311180	1S1588	2 B. 2 A
	or	or	
D13, 14	0311160	1S2473D	2 B. 2 A
	or	or	
D15, 16	0311180	1S1588	2 B. 2 A
	or	or	
ZD01, 02	0316070	EGA01-24R	1 B. 1 A
R33, 34	0191181	180Ω	3 B. 3 A
R35, 36	0191479	4.7Ω	1 B. 1 A
R37, 38	0210392	3.9kΩ 1/2W M.R.	1 B. 1 A
R39, 40	0192100	10Ω	3 B. 3 A
R41, 42	0192151	150Ω	3 B. 3 A
R43, 44	0192151	150Ω	2 B. 2 A
R47, 48	0192479	4.7Ω	3 B. 3 A
R49, 50	0192479	4.7Ω	3 B. 3 A
VR01, 02	1035350	4.7kΩ (B)	Semi-Variable
VR03, 04	1035310	1kΩ (B)	Resistor
	2410930	4P Pin Ass'y (Type E)	
	2420520	6P Connector (Type A)	
	5936691	Heat Sink	

### Parts List

Parts No.	Stock No.	Description	Position	Parts No.	Stock No.	Description	Position
TR01, 02	0306270	2SC1708 (F)	1 B. 1 A	TR07, 08	0306401	2SC1904 (B)	3 B. 3 A
	or	or					
	0306271	2SC1708 (G)					
TR03, 04	0306270	2SC1708 (F)	Transistor	TR09, 10	0305871, 2	2SC984 (B, C)	2 B. 2 A
	or	or					
	0306271	2SC1708 (G)					
TR05, 06	0300791	2SA899 (B)	1 B. 1 A	TR11, 12	0308431	2SD381 (M)	2, 3 B. 2, 3 A
	or	or					
	0300792	2SA899 (V)					
				TR13, 14	0303261	2SB536 (M)	2, 3 B. 2, 3 A
			or		or		
			0303262		2SB536 (L)		

## 5-10. F-2632 Selector Circuit Board (Stock No. 7594371 MODEL QRX-8001 Only)

Conductor Side

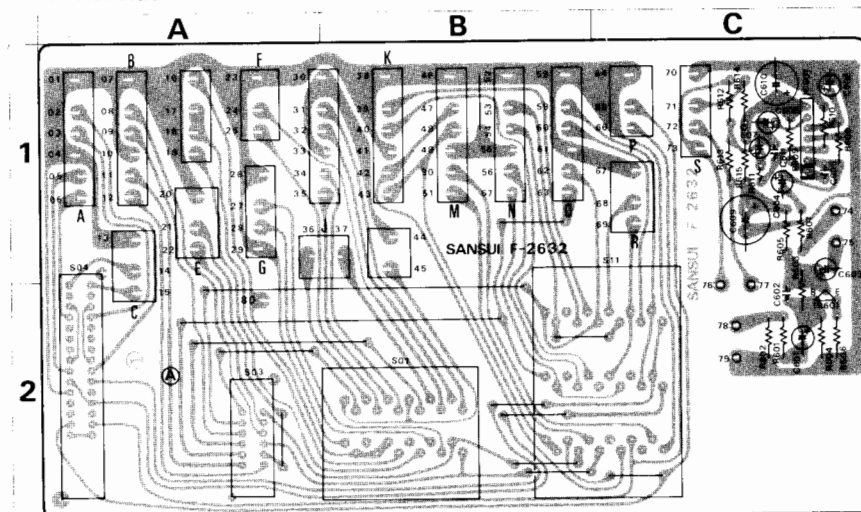

### Parts List

Parts No.	Stock No.	Description	Position
TR601	0306070, 1	2SC1313 (F, G)	Transistor
IC601	0360200	BA3125	I.C.
C601	0573108	0.1μF 35WV	T.C.
S01	1102720	Rotary Switch, SELECTOR	2 B
S03	1170780	Lever Switch, AUX	2 A
S04	1170820	Lever Switch, DOLBY ADAPTOR	2 A
S11	1103570	Rotary Switch, LOUDNESS	2 B. C
	2410590	4P Pin Ass'y (Type D)	
	2410600	6P Pin Ass'y (Type D)	
	2410910	2P Pin Ass'y (Type E)	
	2410920	3P Pin Ass'y (Type E)	

## 5-11. F-2642 Indicator Circuit Board (Stock No. 7594321 MODEL QRX-9001) (Stock No. 7594391 MODEL QRX-8001)

Conductor Side



### Parts List

Parts No.	Stock No.	Description
LD01	0319060	SG2-12C (Red)
LD02-06	0319060	SG2-12C (Red)
		Light Emitted
		Diode

**5-12. F-2087 QS Matrix Circuit Board** (Stock No. 7650481 MODEL QRX-9001) (Stock No. 7650531 MODEL QRX-8001)

Conductor Side

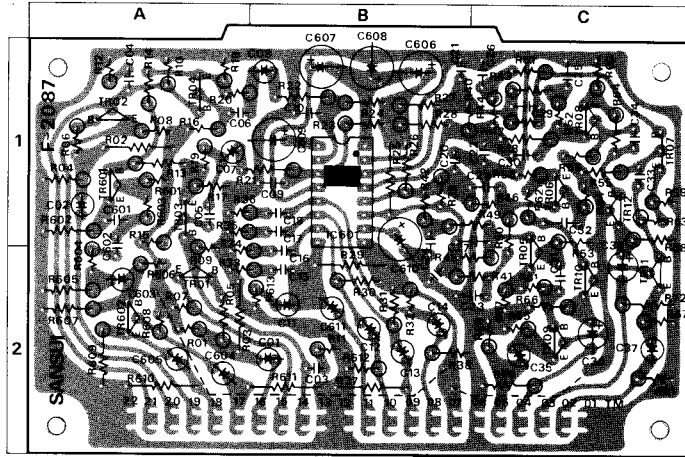

**Parts List**

Parts No.	Stock No.	Description	Position
TR01	0300470, 1	2SA726 (F, G)	2 A
TR02	0300470, 1	2SA726 (F, G)	1 A
TR03, 04	0306090, 1	2SC1312R (F, G)	1 A
TR05, 06	0306091, 2	2SC1312R (G)	1, 2C, 1C
TR07	0306091, 1	2SC1312R (G)	1 C
TR08	0306091, 1	2SC1312S (G)	1 C
TR09, 12	0306090, 1	2SC1312R (F, G)	2 C, 1 C
TR001	0306090, 1	2SC1312R (F, G)	1 A
TR002	0306090, 1	2SC1312R (F, G)	2 A
IC601	0360210	HA1328 I.C.	1 B
C19	0620561	560pF	1 B
C20	0620561	560pF	1 B
C21	0620561	560pF } 50V P.C.	1 B
C22	0620561	560pF	1 C
C33	0620561	560pF	1 C
	2420520	6P Connector (Type A)	
	2420530	8P Connector (Type A)	

**5-13. F-2088 QS Phase Discriminator Section Circuit Board**

(Stock No. 7650491 MODEL QRX-9001) (Stock No. 7650541 MODEL QRX-8001)

Conductor Side

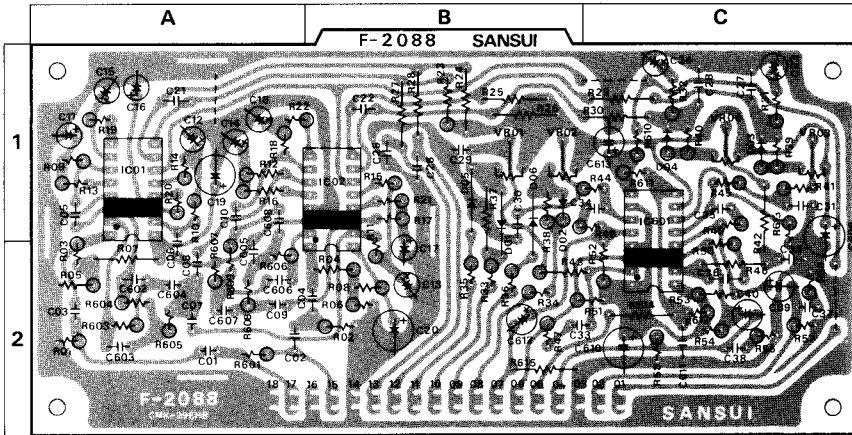

Parts No.	Stock No.	Description	Position
IC601	0360100	HD3103PB I.C.	1, 2 C
D01	0311160	1S2473D	1, 2 B
D02	0311160	1S2473D	1 B
D03	0311160	1S2473D	1 C
D04	0311160	1S2473D	1 C
D05	0311160	1S2473D	1 B
D06	0311160	1S2473D	1, 2 B
C03	0620331	330pF	2 A
C04	0620331	330pF	2 B
C07	0620681	680pF	2 A
C08	0620681	680pF	2 A
C09	0620681	680pF } 50V P.C.	2 A
C10	0620681	680pF	1 A
C604	0620471	470pF	2 A
C607	0620471	470pF	2 A
C608	0620471	470pF	1 A
VR01	1035490	1MΩ(B)	1 B
VR02	1035490	1MΩ(B)	1 B
VR03	1035490	1MΩ(B)	1 C
VR04	1035490	1MΩ(B)	1 C
	2420530	8P Connector (Type A)	
	2420540	10P Connector (Type A)	

**Parts List**

Parts No.	Stock No.	Description	Position	Parts No.	Stock No.	Description	Position
IC01	{ 0360090 or 0360091 or 0360092	{ HA1327 (L) or HA1327 (N) or HA1327 (H)	{ I.C. 1 A	IC02	{ 0360090 or 0360091 or 0360092	{ HA1327 (L) or HA1327 (N) or HA1327 (H)	{ I.C. 1 A

**5-14. F-2689 Protector Circuit Board** (Stock No. 7594341 MODEL QRX-9001) (Stock No. 7594411 MODEL QRX-8001)

Conductor Side

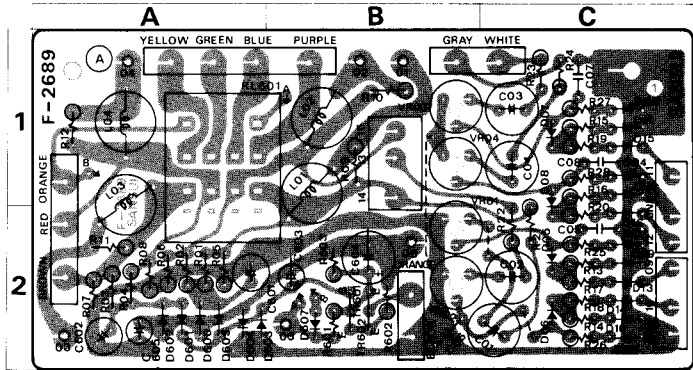

**Parts List**

Parts No.	Stock No.	Description	Position
TR001	0306131, 2	2SC1364 (6, 7)	2 B
TR002	0306131, 2	2SC1364 (6, 7)	2 B
D01-04	0310330, 1	1N60	1, 2 C
	{ 0311160 or 0311180	{ 1S2473D 1S1588	1, 2 C
D09-12	0310330, 1	1N60	1, 2 C
D13-16	0310330, 1	1N60	1, 2 C
D601	0310330, 1	1N60	2 A
D602	0310330, 1	1N60	2 A
D603	0310330, 1	1N60	2 A
D604	0310330, 1	1N60	2 A
D605	0310330, 1	1N60	2 A
D606	0310330, 1	1N60	2 A
D607	0310340	10D-1	2 B
R09-12	0103479	4.7Ω 1/2W C.R.	1B, 1, 2A
R21-24	0210471	470Ω 1/2W N.I.R. (MODEL QRX-9001 Only)	1, 2 C
L01-04	4290210	Filter Coil	1 A, B
RL601	{ 1150101 or 1150103	{ MY4-02-US RABX-48-DC24V	Relay 1 A
VR01-04	1035110	4.7kΩ(B) Semi-Variable Resistor	1, 2 B
	2410670	3P Pin Ass'y (Type F)	
	2410920	3P Pin Ass'y (Type E)	

**5-15. F-2589 Equalizer & CD-4 Circuit Board** (Stock No. 7551021 MODEL QRX-9001)  
(Stock No. 7551011 MODEL QRX-8001)

Conductor Side

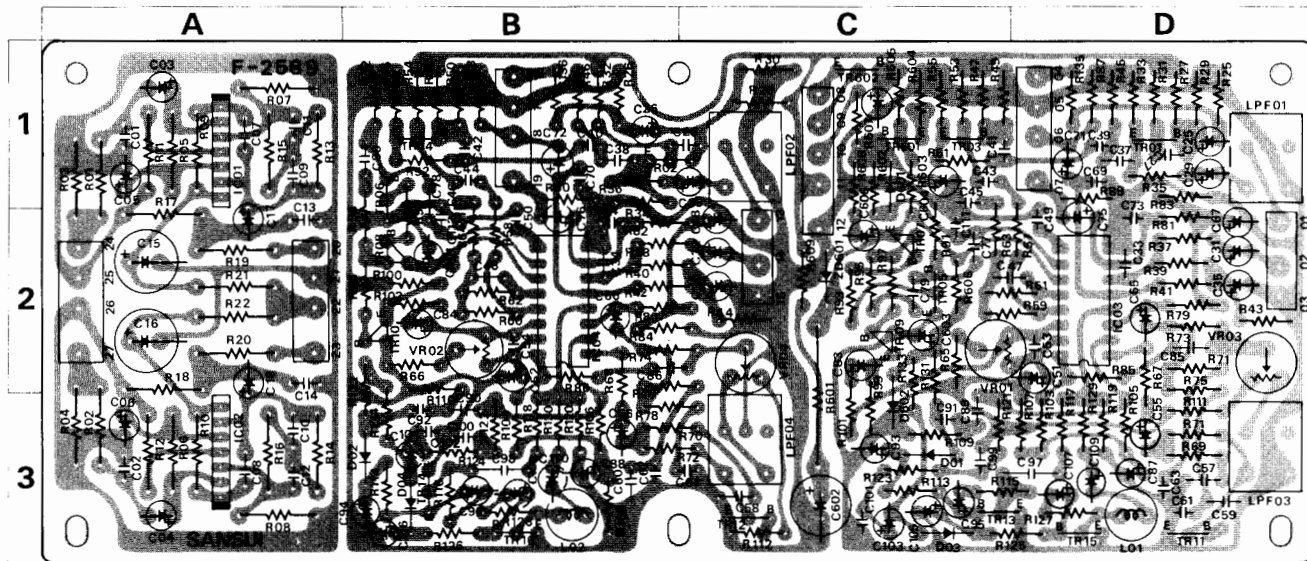

**Parts List**

Parts No.	Stock No.	Description	Position	Parts No.	Stock No.	Description	Position	Parts No.	Stock No.	Description	Position		
TR01.02	0306011.2	2SC1222 (E, F)	1D. 1A, 8	IC01.02	0360190	BA312	1A. 3A	R601	0182151	150Ω 2W Ce.R.	2.3C		
	0306070.1	2SC1313 (F, G)		IC03.04	0360330	CD4-392	I.C.	2D. 2B	L01.02	4900220	100mH Inductor	3D. 3B	
TR03.04	0306011.2	2SC1222 (E, F)	1C. 1B	D01.02	0311160	1S2473D	3C. 3B	LF01.02	0910340	DC-13Q	Ceramic Filter		
	0306070.1	2SC1313 (F, G)		D03.04	0311160	1S2473D	3C. 3B	LF03.04	4910340	DC-13Q			
TR05.06	0305951-3	2SC945 (Q, P, K)	Transistor	D601	0311180	1S1588	Diode	VR01.02	1035130	10kΩ(B)	2C. D. 2B		
TR07.08	0300510.1	2SA733 (P, Q)			0311180	1S1588		2D. 2C	VR03.04	1035100	3.3kΩ(B)	Semi-Variable Resistor	2D. 2C
TR09.10	0305951-3	2SC945 (Q, P, K)	2C. 2B	D602	0311160	1S2473D	2.3C	2410570	3020-5A	5P Pin Ass'y (Type D)	2410580	3020-3A	3P Pin Ass'y (Type D)
TR11.12	0305951-3	2SC945 (Q, P, K)	2C. 2B		0311180	1S1588		2.3C	2410580	3020-3A		3P Pin Ass'y (Type D)	
TR13.14	0305952	2SC945 (P)	3D. 3C	ZD601		0311180	1S1588		2410590	3020-4A		4P Pin Ass'y (Type D)	
TR15.16	0305952	2SC945 (P)	3D. 3B			0316290	RD-12E(B)						
TR601	0305951-3	2SC945 (Q, P, K)	1C	C103.104	0573228	0.22μF	3C. 3B						
TR602	0305951-3	2SC945 (Q, P, K)	1C	C109.110	0573688	0.68μF	3D. 3B						

**5-16. F-2688 Dolby Circuit Board** (Stock No. 7660081 MODEL QRX-9001 Only)

Conductor Side

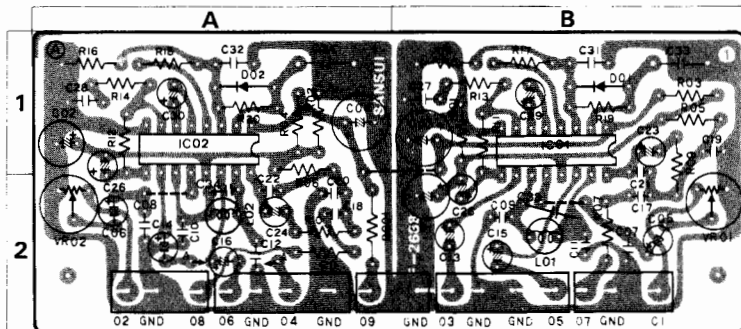

**Parts List**

Parts No.	Stock No.	Description	Position
IC01.02	0360340	NE545B IC	1B. 1A
D01.02	0310400	1N34A Diode	1B. 1A
R601	0201820	82Ω 1W M.R.	2A
L01.02	4900260	Inductor	2B. 2A
VR01.02	1035430	100kΩ (B) Semi-Variable Resistor	2B. 2A
	2410680	4P Pin Ass'y (Type F)	

**5-17. F-2640 Illumination Circuit Board (1)**

(Stock No. 7594351 MODEL QRX-9001)  
(Stock No. 7594421 MODEL QRX-8001)

**Parts List**

Parts No.	Stock No.	Description
	7726200	Lamp Ass'y (C) (MODEL QRX-9001 Only)

**5-18. F-2641 Illumination Circuit Board (2)**

(Stock No. 7594361 MODEL QRX-9001)  
(Stock No. 7594431 MODEL QRX-8001)

**Parts List**

Parts No.	Stock No.	Description
R01	0193220	22Ω 1/2W F.R.
	7726210	Lamp Ass'y (D)
	7726200	Lamp Ass'y (C) (MODEL QRX-9001 Only)

**5-19. F-2635 4-ch Function Switch & REC CAL  
Tone Sub Circuit Board** (Stock No. 7650471 MODEL QRX-9001)  
(Stock No. 7650521 MODEL QRX-8001)

### 5-20. F-2633 Dolby Change Circuit Board (Stock No. 7660061 MODEL QRX-9001 Only)

Conductor Side

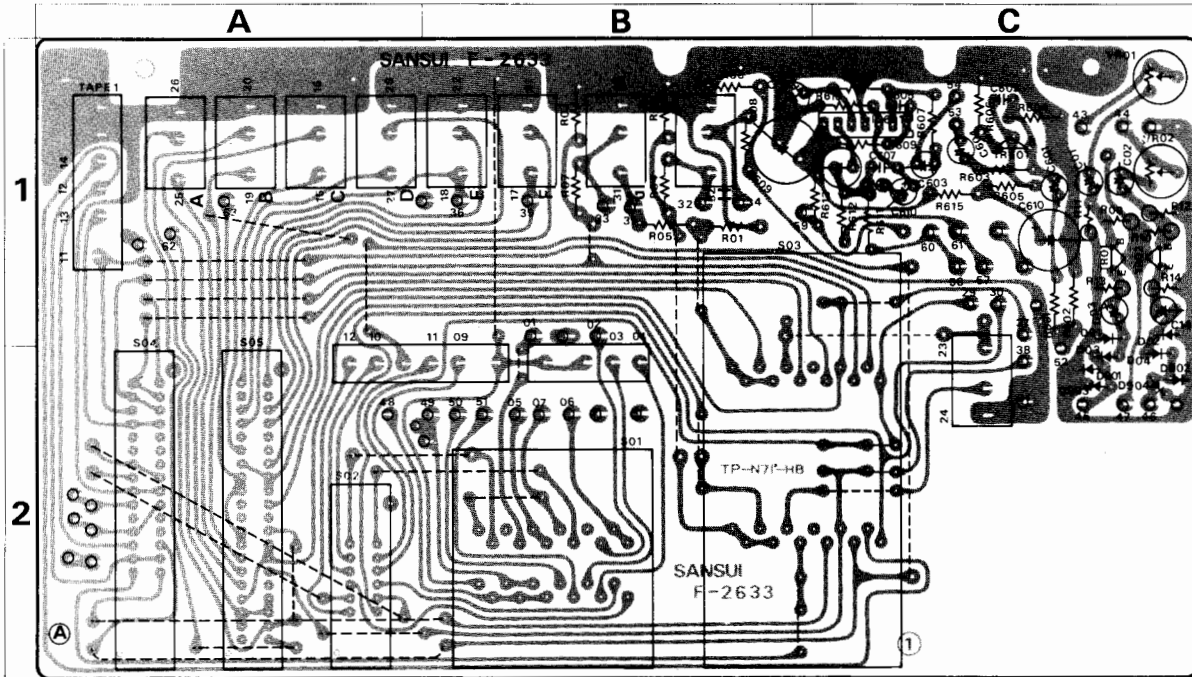

**Parts List**

Parts No.	Stock No.	Description	Position	Parts No.	Stock No.	Description	Position	Parts No.	Stock No.	Description	Position
TR01, 02	0305732 or 0305733 0306070 or 0306071	25C711 (F) 25C711 (G) 25C1313 (F) 25C1313 (G)	1 C	D03, 04	0310330, 1	1N60	2 C	S04	1170820	Lever Switch, TAPE MONITOR (2 Contact)	2 A
TR01, 02	0306070 or 0306071	25C1313 (F) 25C1313 (G)		D901, 902	0310330, 1	1N60		S05	1171000	Lever Switch, TAPE MONITOR (3 Contact)	
TR01, 02	0306071	25C1313 (G)	D903, 904	0310330, 1	1N60	C01		0573108	0.1 $\mu$ F 35V T.C.	1 C	
TR01, 02	0306071	25C1313 (G)	1 C	VR01, 02	1035410	47k $\Omega$ (B) Semi-Variable Resistor	1 C	2410590	4P Pin Ass'y (Type D)		
IC01	0360200	BA312S IC	1 C	S01	1102720	Rotary Switch, SELECTOR	2 B	2410600	6P Pin Ass'y (Type D)		
D01, 02	0310330, 1	1N60 Diode	1 C	S02	1105230	Rotary Switch, AUX	2 A	2410670	3P Pin Ass'y (Type F)		
				S03	1170780	Lever Switch, DOLBY NR	1, 2 B C				

### 5-21. F-2686 4-ch Function Switch & REC CAL Tone Sub Circuit Board (Stock No. 7650511 MODEL QRX-9001) (Stock No. 7650561 MODEL QRX-8001)

### 5-22. F-2652 Dolby Sub Circuit Board (Stock No. 7660071 MODEL QRX-9001 Only)

### 5-23. Figures Connectors & Pin Ass'y

**Connectors**

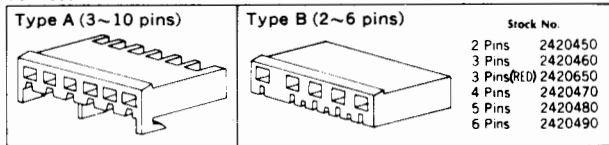

NOTE: Since stock number of female connectors (type B) with wires are not shown in each parts list of Complete circuit board, please refer to the above parts list when ordering the connector.

**Abbreviations**

<b>C.R.</b> : Carbon Resistor	<b>E.C.</b> : Electrolytic Capacitor
<b>S.R.</b> : Solid Resistor	<b>BP.E.C.</b> : Bi-Polar Electrolytic Capacitor
<b>Ce.R.</b> : Cement Resistor	<b>C.C.</b> : Ceramic Capacitor
<b>M.R.</b> : Metallized Film Resistor	<b>Mi.C.</b> : Mica Capacitor
<b>F.R.</b> : Fusing Resistor	<b>O.C.</b> : Oil Capacitor
<b>N.I.R.</b> : Non-Inflammable Resistor	<b>P.C.</b> : Polystyrene Capacitor
<b>M.C.</b> : Mylar Capacitor	<b>T.C.</b> : Tantalum Capacitor

**Pin Ass'y**

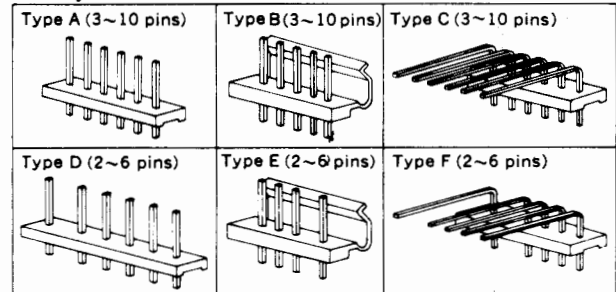

## 6. OTHER PARTS/6-1. QRX-8001

### Top Side

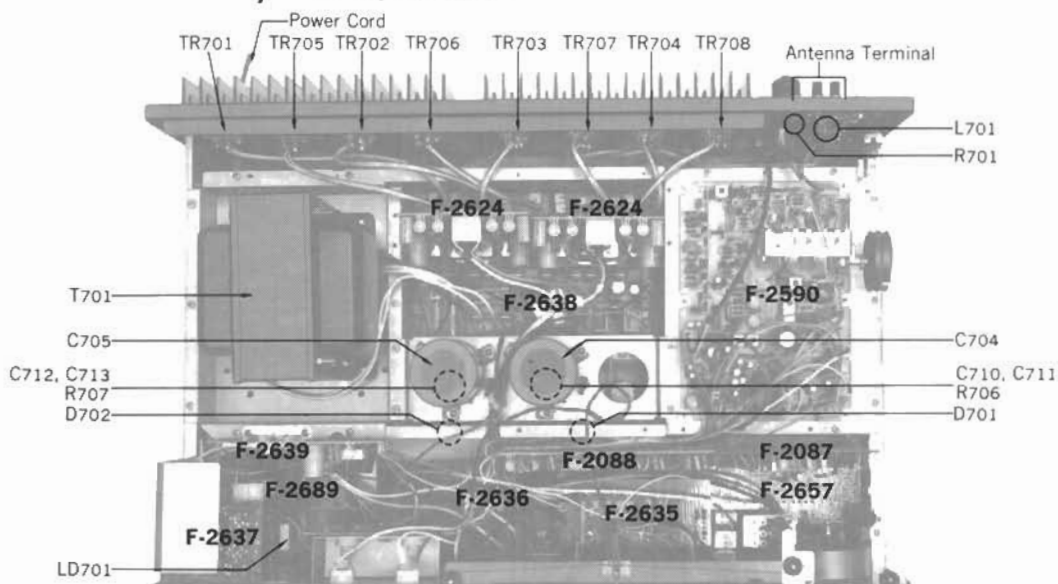

### Bottom Side

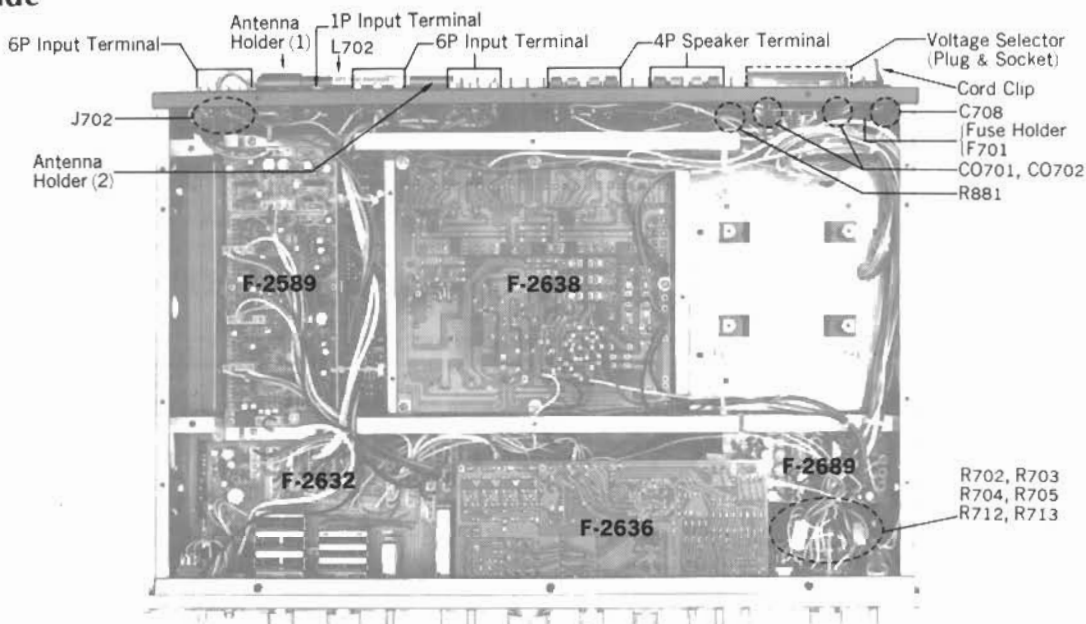

### Parts List (Top Side & Bottom Side)

Parts No.	Stock No.	Description	Parts No.	Stock No.	Description	Parts No.	Stock No.	Description	
TR701-704	0303430	25B611 (B)	R702-705	0163221	2201Ω 3W Ce.R.	J702	2430041	5P DIN Jack	
	0303431	25B611 (C)		R706	0202332		3.3k1Ω 2W MR	2030040	Transistor Socket
	0308600	25D581 (B)		R707	0202332		3.3k1Ω 2W MR	2200290	1P Output Terminal
	0308601	25D581 (C)		R712	0201122		1.2k1Ω 1W N/R	2200330	6P Input Terminal
TR705-708	0308600	25D581 (B)	R713	0201392	3.9k1Ω 1W N/R	2210310	Antenna Terminal		
	0308601	25D581 (C)	R881	0114335	3.3M1Ω 1/2W SR	2290160	4P Speaker Terminal		
D701	0311440	SG-S1 (S)	L701	4290021	75Ω/300Ω Antenna Transformer	2200320	4P Input Terminal		
D702	0311450	SG-S1 (R)	L702	4200830	ARS-26 235-H	2410091	Voltage Selector, plug		
LD701	0319090	Light Emitted Diode		4200831	6G-013 265-H	2410830	Voltage Selector, socket		
				4200831	6G-013 265-H	2230052	Ground Terminal		
C704	0559350	1.5000-#F 50V E.C.	T701	4002510	Power Transformer	3800010	Power Cord		
C705	0559350	1.5000-#F 50V E.C.	F701	0432500	7A 125V (AC 100-120V)	3910490	Cord Clip, power cord		
C707	0605337	0.033-#F 250V M.C.		0432280	4A 125V (AC 220-240V)	5286480	Antenna Holder (1)		
C708	0659802	0.0047-#F 150V C.C.		2300060	Fuse Holder	5286450	Antenna Holder (2)		
C710-C713	0655103	10000 pF 500V C.C.	CO701,702	2450060	AC Outlet				
R701	0103122	1.2k1Ω 1/2W Ce.R.							

## 6-2. QRX-9001

### Top Side

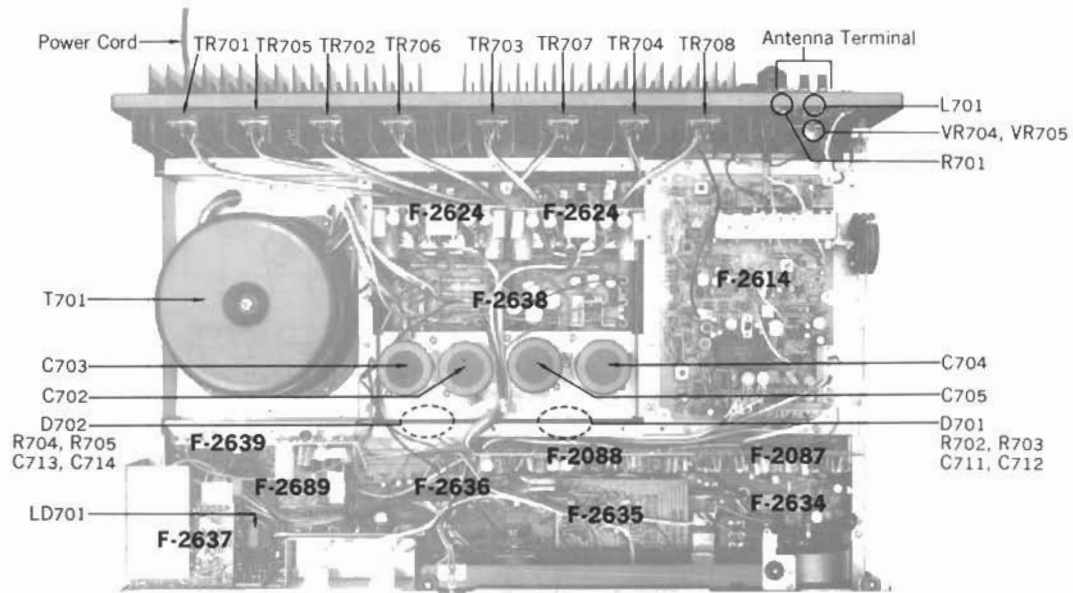

### Bottom Side

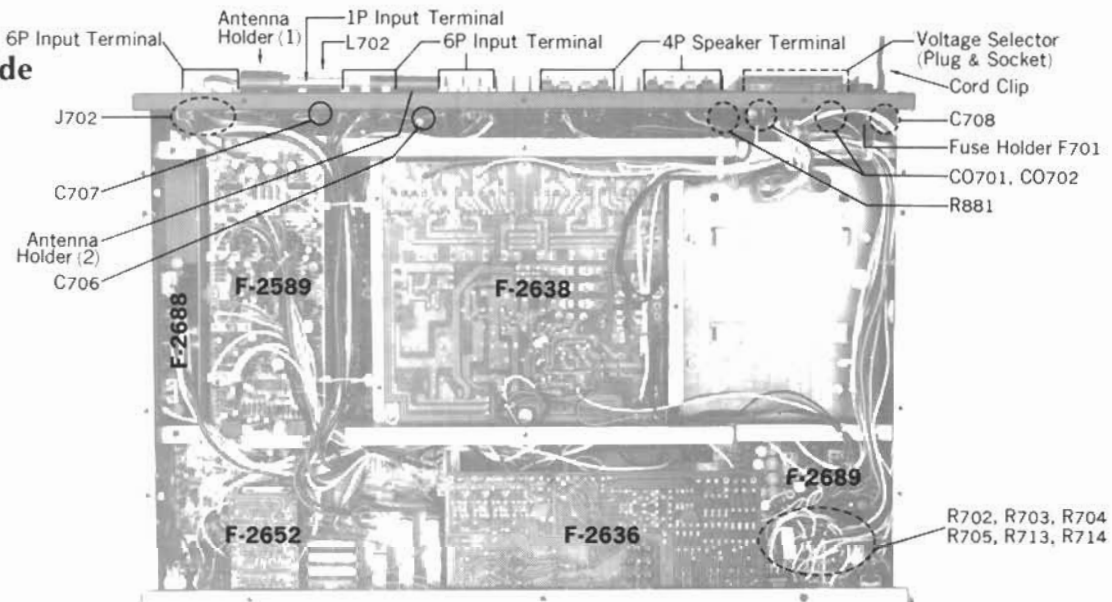

### Parts List (Top Side & Bottom Side)

Parts No.	Stock No.	Description
TR701-704	0306230 or 0306231 0300870 or 0300871	25C1115 (P) 25C1115 (O) 25A746 (P) 25A746 (O)
TR705-708	0300870 or 0300871	25A746 (P) 25A746 (O)
D701	0311440	SG-5T (S)
D702	0311450	SG-5T (S)
LD701	0319090	Light Emitted Diode
C702-703	0559360	10000 (F)
C704-705	0559360	10000 (F) 50V E.C.
C707	0605337	0.033 (F) 250V M.C.
C708	0659802	0.0047 (F) 150V C.C.
C711-714	0655103	10000 (F) 500V C.C.
R701	0103122	1.2k $\Omega$ 1/2W C.R.

Parts No.	Stock No.	Description
R702-705	0163221	220 $\Omega$ 3W C.R.
R706-707	0202332	3.3k $\Omega$ 2W M.R.
R712	0202152	1.5k $\Omega$ 2W C.R.
R713	0201392	3.9k $\Omega$ 1W C.R.
R881	0114335	3.3M $\Omega$ 1/2W S.R.
VR704, 705	1005300, 1	5k $\Omega$ CD-4 Adjust Volume
T701	4002500	Power Transformer
L701	4290021	75 $\Omega$ /300 $\Omega$ Antenna Transformer
L702	4200830 or 4200831	235 $\mu$ H AR5-26 Bar Antenna 265 $\mu$ H 6G-013 Bar Antenna
F701	2300060 0432290 0434060	Fuse Holder 5A 125V (AC 220-240V) 10A 250V (AC 100-120V)

Parts No.	Stock No.	Description
J702	2430041	5P DIN Jack
	2030040	Transistor Socket
	2200290	1P Output Terminal
	2200330	6P Input Terminal
	2210310	Antenna Terminal
	2290160	4P Speaker Terminal
	2410091	Voltage Selector plug
	2410830	Voltage Selector socket
	3800010	Power Cord
	3910490	Cord Clip power cord
	2230052	Ground Terminal
	2200320	4P Input Terminal
	5286480	Antenna Holder (1)
	5286450	Antenna Holder (2)

1.4 5318750 D-7 Type Knob  
1.5 7001381 1/4" Power Assy (MODEL QRX 8001)  
2.5 1060380, 1 1060330, 1 Balance Volume (Left) +right  
2.6 1060330, 1 Balance Volume (Front) +Back  
3.6 1005300, 1 1013210, 1 QRX 9001, 1 CD-4 Separator Volume (MODEL QRX 8001) REC Level Volume: 9001.1 (B) - 2  
5.0 7136082 Terminal Unit  
5.1 5038670 Bottom Plate  
5.2 5317050 Top Terminal Lead  
1900050 Terminal Lead Switch

### 6-3. Exploded View (QRX-8001/9001)

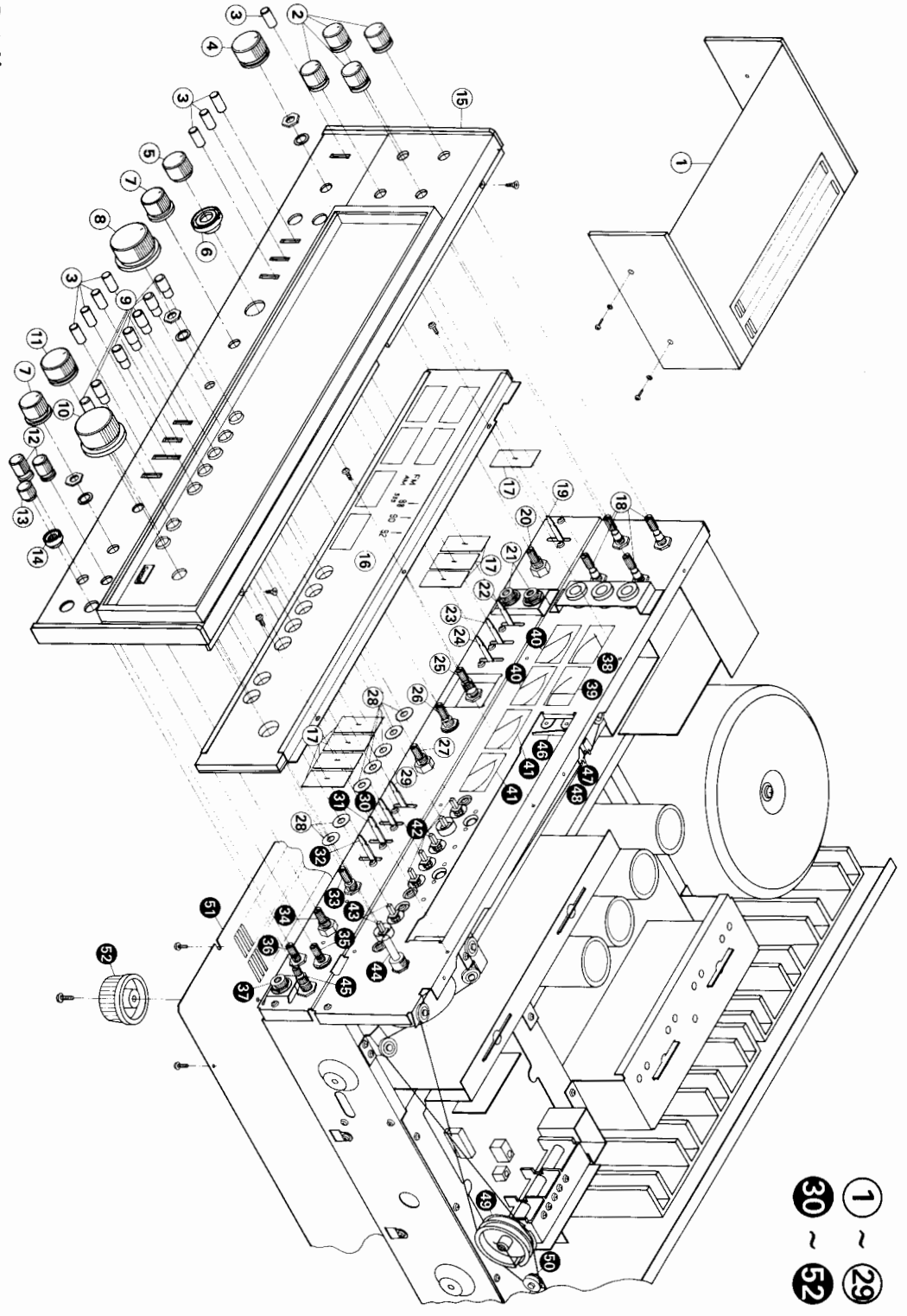

1 ~ 29  
30 ~ 52

Parts No.	Stock No.	Description	Parts No.	Stock No.	Description	Parts No.	Stock No.	Description	Parts No.	Stock No.	Description
1	5727030	Wood Borer	16	5047470	Dial Glass (MODEL QRX-9001)	31	1171000	Tape Monitor Switch (MODEL QRX-9001)	41	4300920	Power Meter (MODEL QRX-9001)
2	5318720	F-13 Type Knob	17	1015200-1	Muting Switch (MODEL QRX-9001)	32	1170780	Aux Switch	42	1131350	Signal Meter
3	71004130	Level Switch Knob - C-2 Type	18	1170510	Power Control Volume (100kΩ) (B)	33	1102720	Auto Switch	43	4300740	Tuner Meter
4	5318380	M.F. 7 Type Knob	19	1170880	Speaker Selector	34	1103570	Dolby NR Switch (MODEL QRX-8001)	38	4300750	Power Meter (MODEL QRX-8001)
5	5318720	W.O. 10 Type Knob	20	2430120	Speaker Selector	35	1005300-1	Play Call Volume (500kΩ) (B) - 2 (MODEL QRX-9001)	40	4301010	Power Meter (Dolby Mark (MODEL QRX-9001))
6	5318790	S-10 Type Knob	21	1170880	High Filter Switch	36	1005300-1	REC-4 Separator Volume (MODEL QRX-8001)	41	4300920	Power Meter
7	5318410	M-8 Type Knob	22	1170880	Low Filter Switch	37	1015210-1	REC Level Volume (500kΩ) (B) - 2	42	1131350	Signal Meter
8	5318780	M-7 Type Knob	23	1170880	High Filter Switch	38	1015210-1	REC Level Volume (500kΩ) (B) - 2	43	4300740	Tuner Meter
9	5326590	Volume Knob - M-8 Type	24	1060380-1	Balance Volume (Left - Right)	39	1015210-1	REC Level Volume (500kΩ) (B) - 2	44	7034501	Tuner Meter
10	5318420	Push Knob	25	1065030-1	Balance Volume (Front - Back)	40	1015210-1	REC Level Volume (500kΩ) (B) - 2	45	1005010-1	Tuner Meter
11	5318380	F-7 Type Knob	26	1065030-1	Balance Volume (Front - Back)	41	1015210-1	REC Level Volume (500kΩ) (B) - 2	46	5416451	Holder, Dial Pointer
12	5318761	N-6 Type Knob (MODEL QRX-9001)	27	1065030-1	Balance Volume (Front - Back)	42	1015210-1	REC Level Volume (500kΩ) (B) - 2	47	5416451	Holder, Dial Pointer
13	5318741	C-7 Type Knob	28	1065030-1	Balance Volume (Front - Back)	43	1015210-1	REC Level Volume (500kΩ) (B) - 2	48	6146670	Terion Sheet, Dial Pointer
14	5318750	D-7 Type Knob	29	1065030-1	Balance Volume (Front - Back)	44	1015210-1	REC Level Volume (500kΩ) (B) - 2	49	5516030	Terion Unit
15	7007361	Front Panel Assy (MODEL QRX-8001)	30	1170820	Knob Ring - Sansui Mark	45	1015210-1	REC Level Volume (500kΩ) (B) - 2	50	71346082	Terion Unit
			31	1171000	Dial Glass (MODEL QRX-8001)	46	1015210-1	REC Level Volume (500kΩ) (B) - 2	51	5058670	Bottom Plate
			32	1170780	Muting Switch (MODEL QRX-9001)	47	1015210-1	REC Level Volume (500kΩ) (B) - 2	52	5317050	Leg
			33	1102720	Speaker Selector	48	1015210-1	REC Level Volume (500kΩ) (B) - 2			Thermal Bend Switch
			34	1103570	Speaker Selector	49	1015210-1	REC Level Volume (500kΩ) (B) - 2			
			35	1005300-1	High Filter Switch	50	1015210-1	REC Level Volume (500kΩ) (B) - 2			
			36	1005300-1	Low Filter Switch	51	1015210-1	REC Level Volume (500kΩ) (B) - 2			
			37	1015210-1	Balance Volume (Front - Back)	52	1015210-1	REC Level Volume (500kΩ) (B) - 2			



# 7. SCHEMATIC DIAGRAM/7-1. QRX-8001 Tuner Section

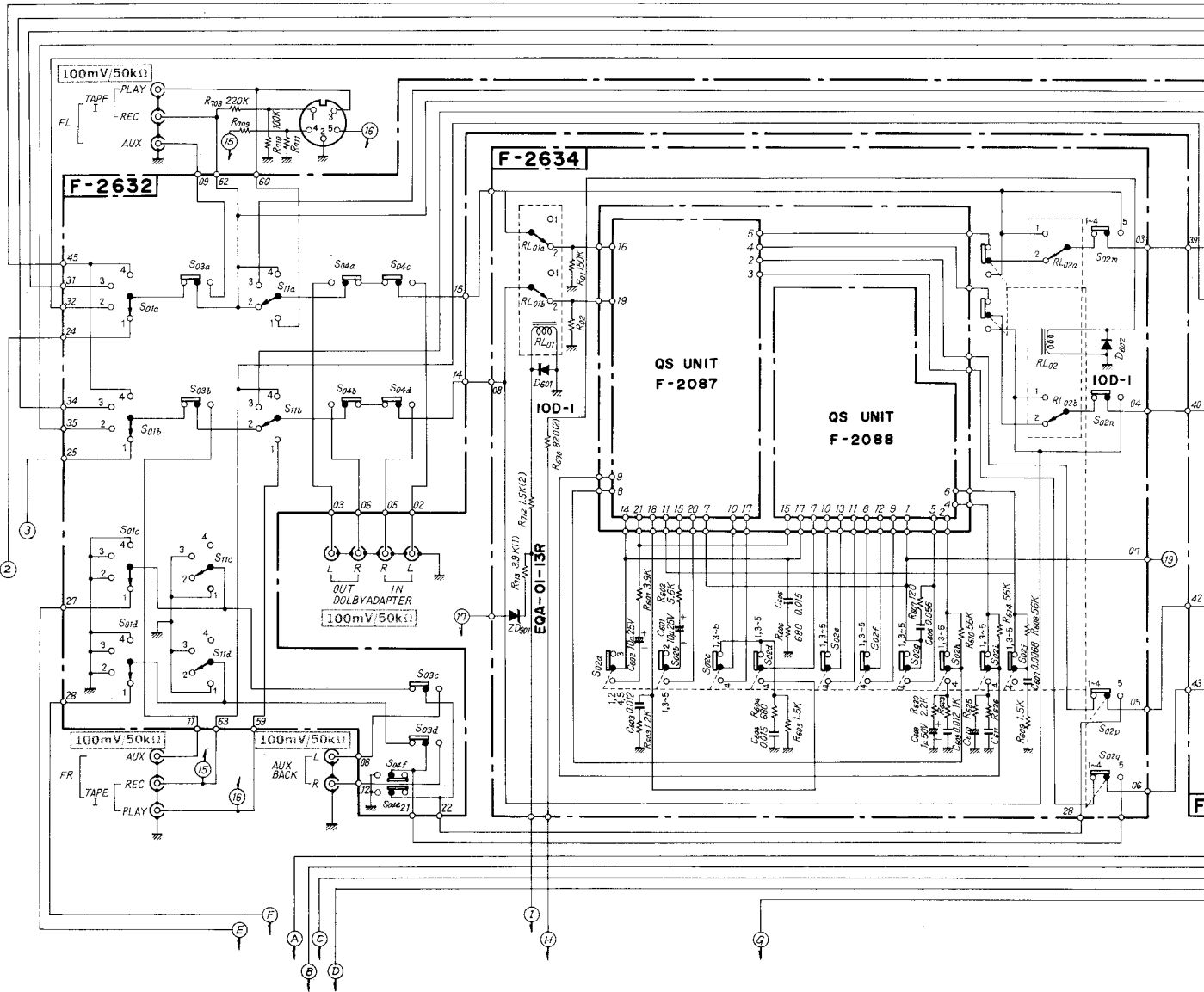
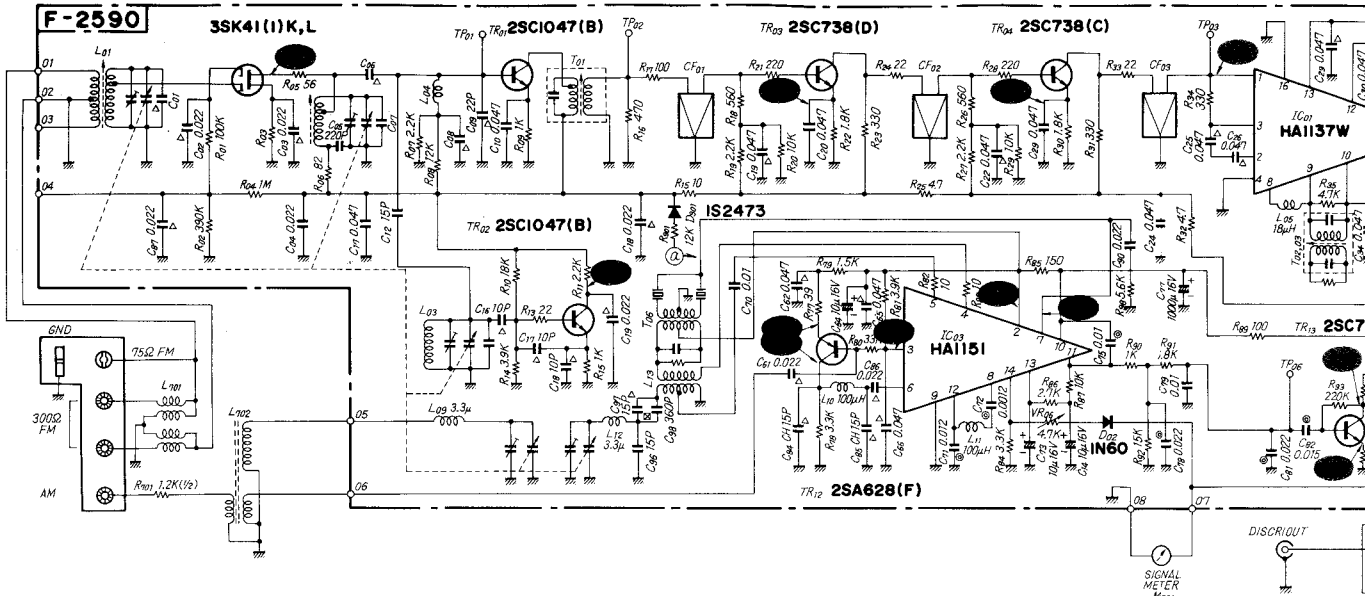

\* La présentation et les spécifications sont susceptibles d'être modifiées sans préavis par suites d'améliorations éventuelles.  
\* Änderungen, die dem technischen Fortschritt dienen, bleiben vorbehalten.  
\* Design and specifications subject to change without notice for improvements.

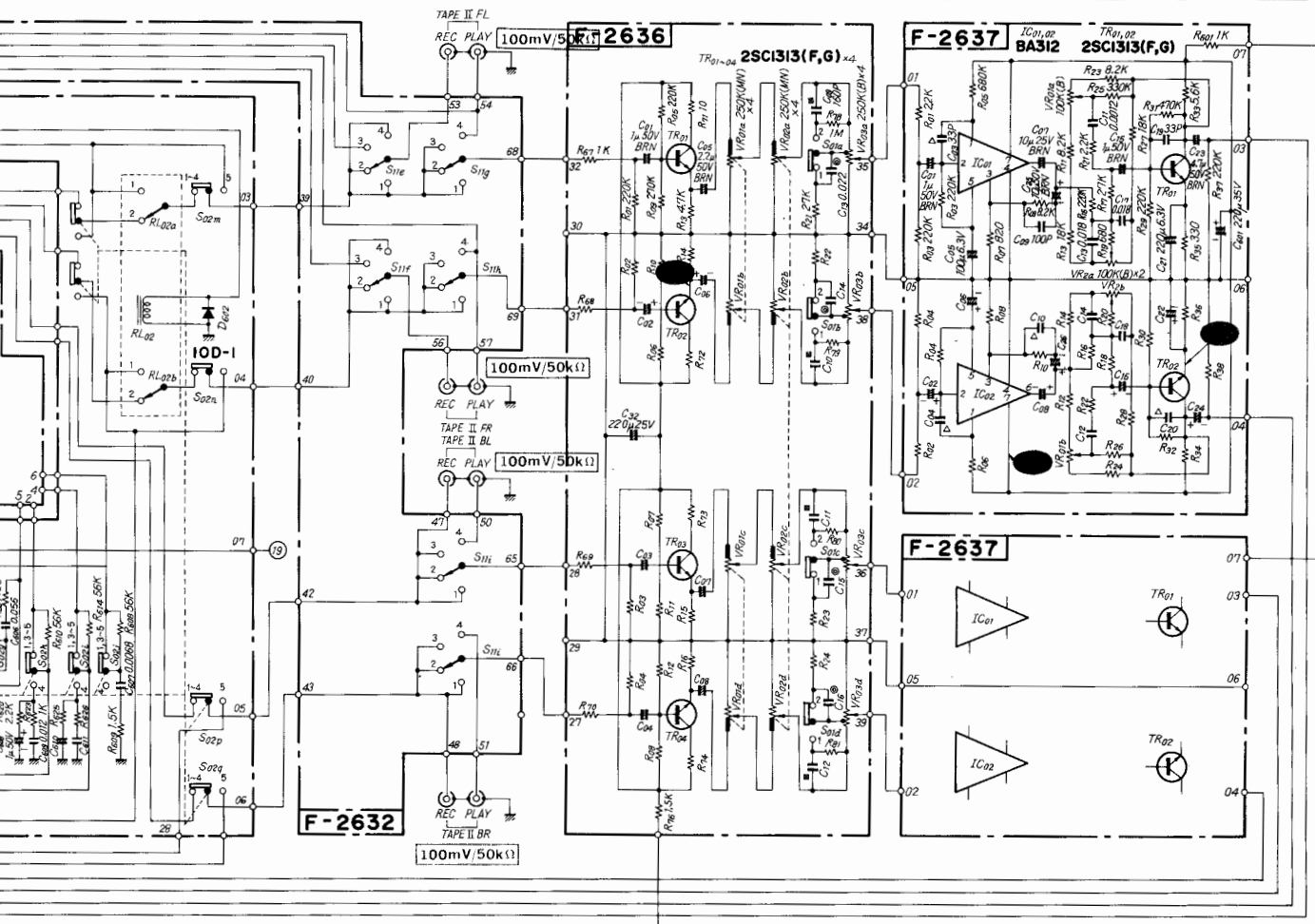
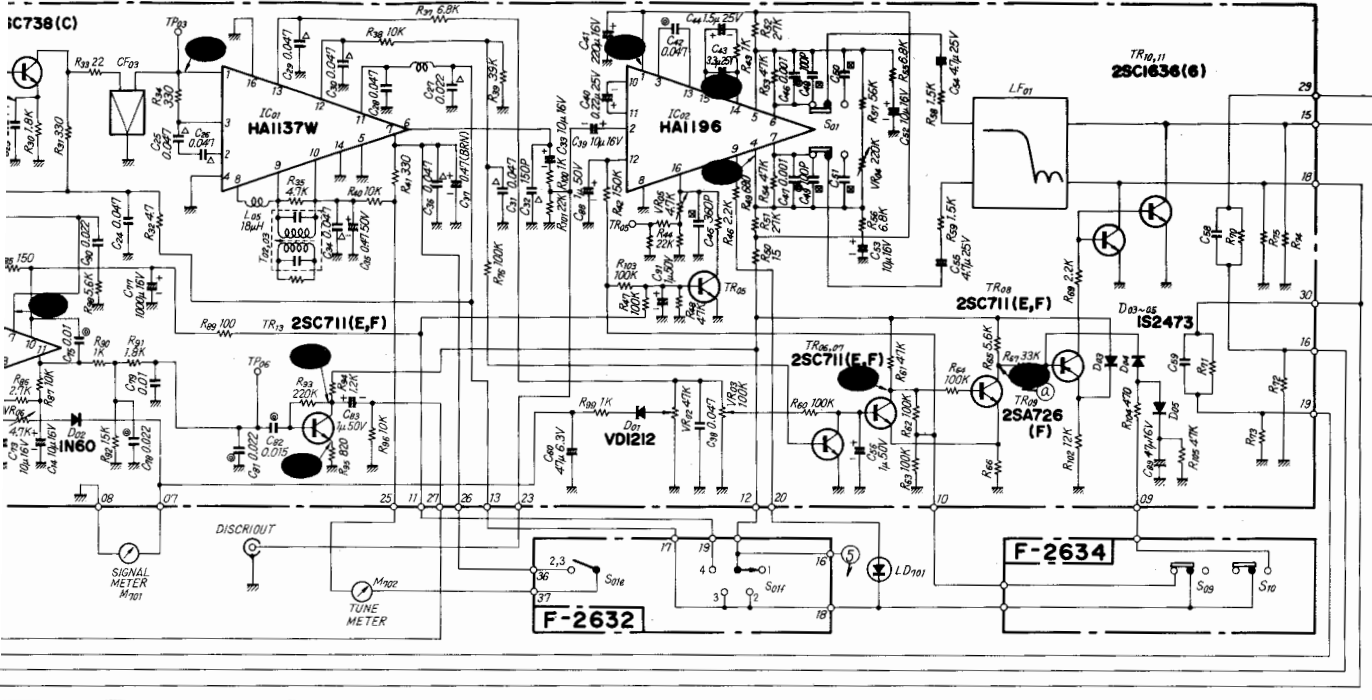

# 7-2. QRX-8001 Audio Section

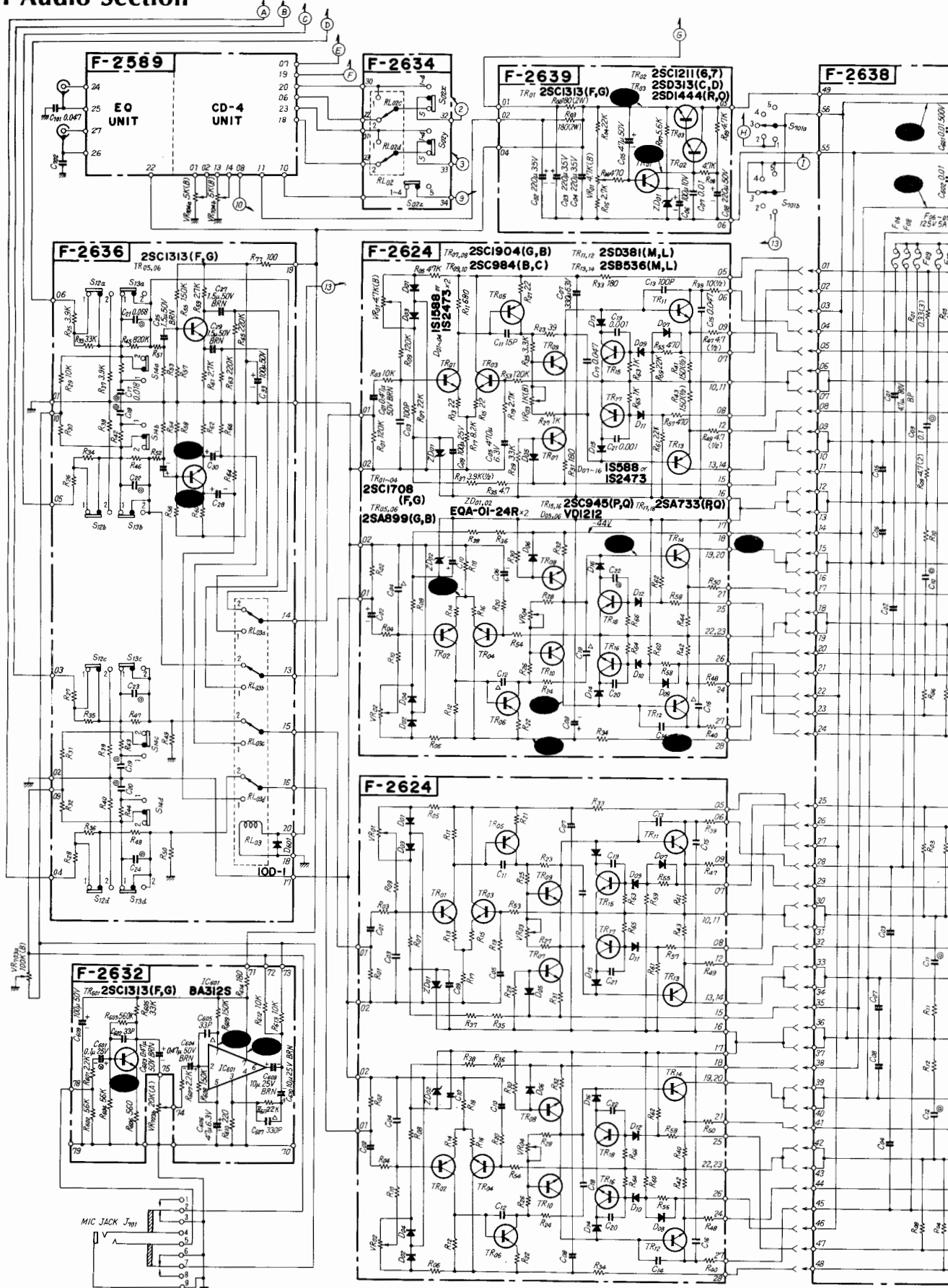

\* La présentation et les spécifications sont susceptibles d'être modifiées sans préavis par suites d'améliorations éventuelles.  
 \* Änderungen, die dem technischen Fortschritt dienen, bleiben vorbehalten.  
 \* Design and specifications subject to change without notice for improvements.

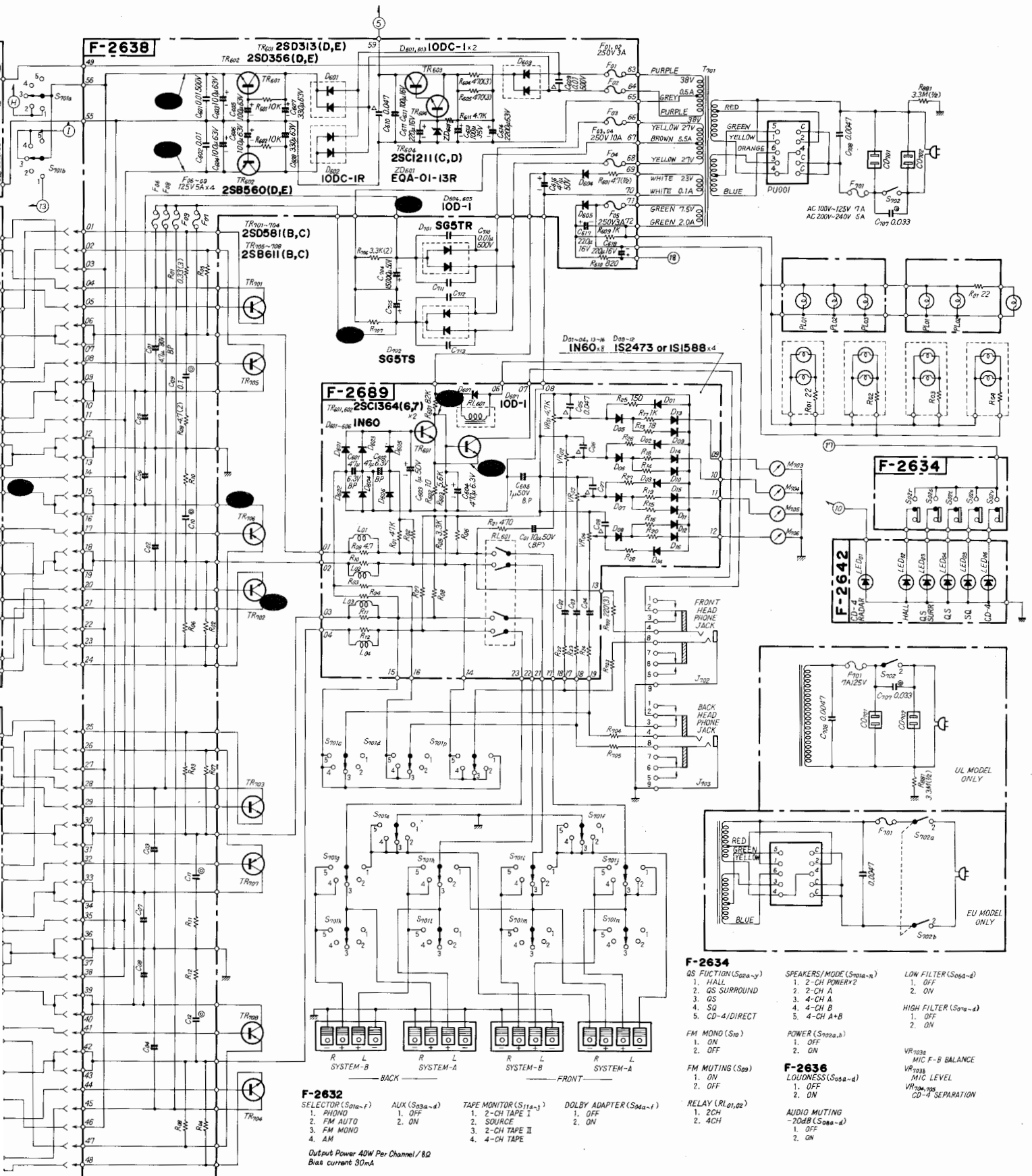

- F-2632**  
 SELECTOR (S102-f)  
 1. PHONO  
 2. FM AUTO  
 3. FM MONO  
 4. AM
- AUX (S202-a-d)  
 1. OFF  
 2. ON
- TAPE MONITOR (S121-a)  
 1. 2-CH TAPE I  
 2. SOURCE  
 3. 2-CH TAPE II  
 4. 4-CH TAPE
- DOLBY ADAPTER (S042-f)  
 1. OFF  
 2. ON
- RELAY (RL61,02)  
 1. 2CH  
 2. 4CH
- Output Power 40W Per Channel / 8Ω  
 Bias current 30mA

- F-2634**  
 QS FUNCTION (S022-a-y)  
 1. HALL  
 2. QS SURROUND  
 3. QS  
 4. SQ  
 5. CD-4/DIRECT
- SPEAKERS/MODE (S702-a)  
 1. OFF  
 2. ON
- LOW FILTER (S062-d)  
 1. OFF  
 2. ON
- HIGH FILTER (S702-e)  
 1. OFF  
 2. ON
- POWER (S7022-a,b)  
 1. OFF  
 2. ON
- F-2636**  
 LOUDNESS (S052-a-d)  
 1. OFF  
 2. ON
- AUDIO MUTING  
 -20dB (S062-a-e)  
 1. OFF  
 2. ON
- VR1032a  
 MIC F-B BALANCE
- VR1033b  
 MIC LEVEL
- VR1034c  
 CD-4 SEPARATION



\* La présentation et les spécifications sont susceptibles d'être modifiées sans préavis par suites d'améliorations éventuelles.  
 \* Änderungen, die dem technischen Fortschritt dienen, bleiben vorbehalten.  
 \* Design and specifications subject to change without notice for improvements.

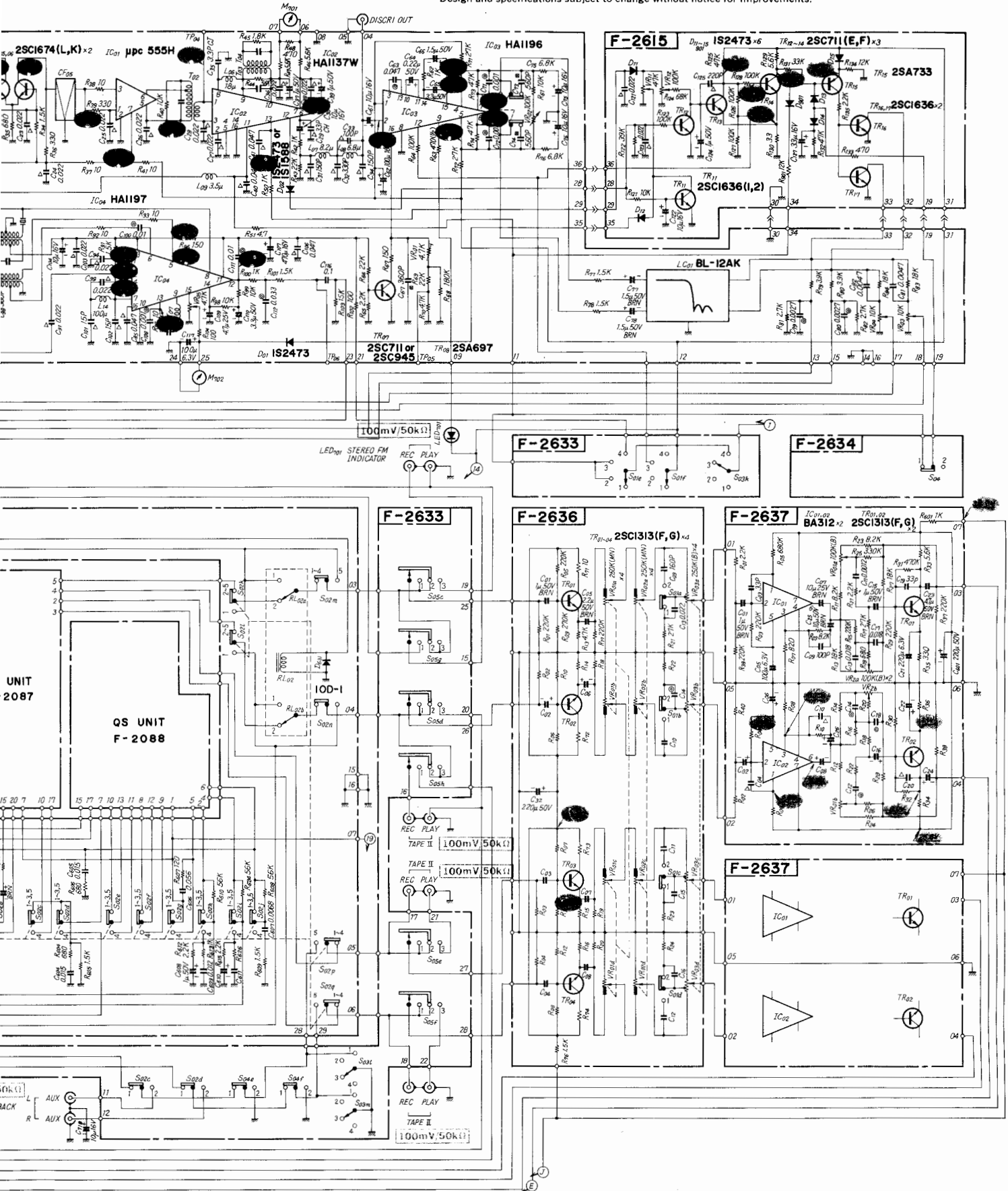

UNIT  
2087

QS UNIT  
F-2088

F-2615

F-2633

F-2633

F-2634

F-2636

F-2637

F-2637

E

# 7-4. QRX-9001 Audio Section

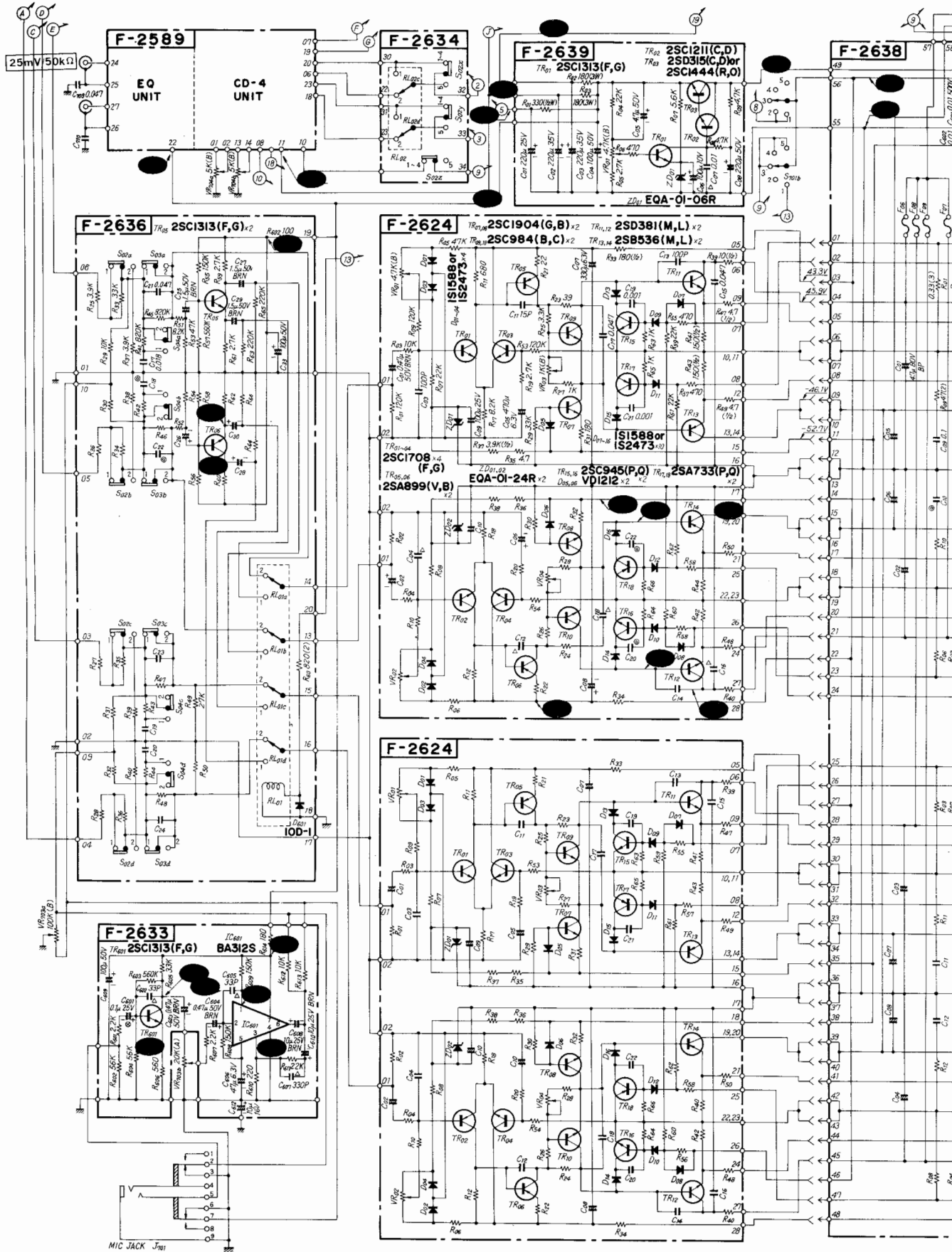

• La présentation et les spécifications sont susceptibles d'être modifiées sans préavis par suites d'améliorations éventuelles.  
 • Änderungen, die dem technischen Fortschritt dienen, bleiben vorbehalten.  
 • Design and specifications subject to change without notice for improvements.

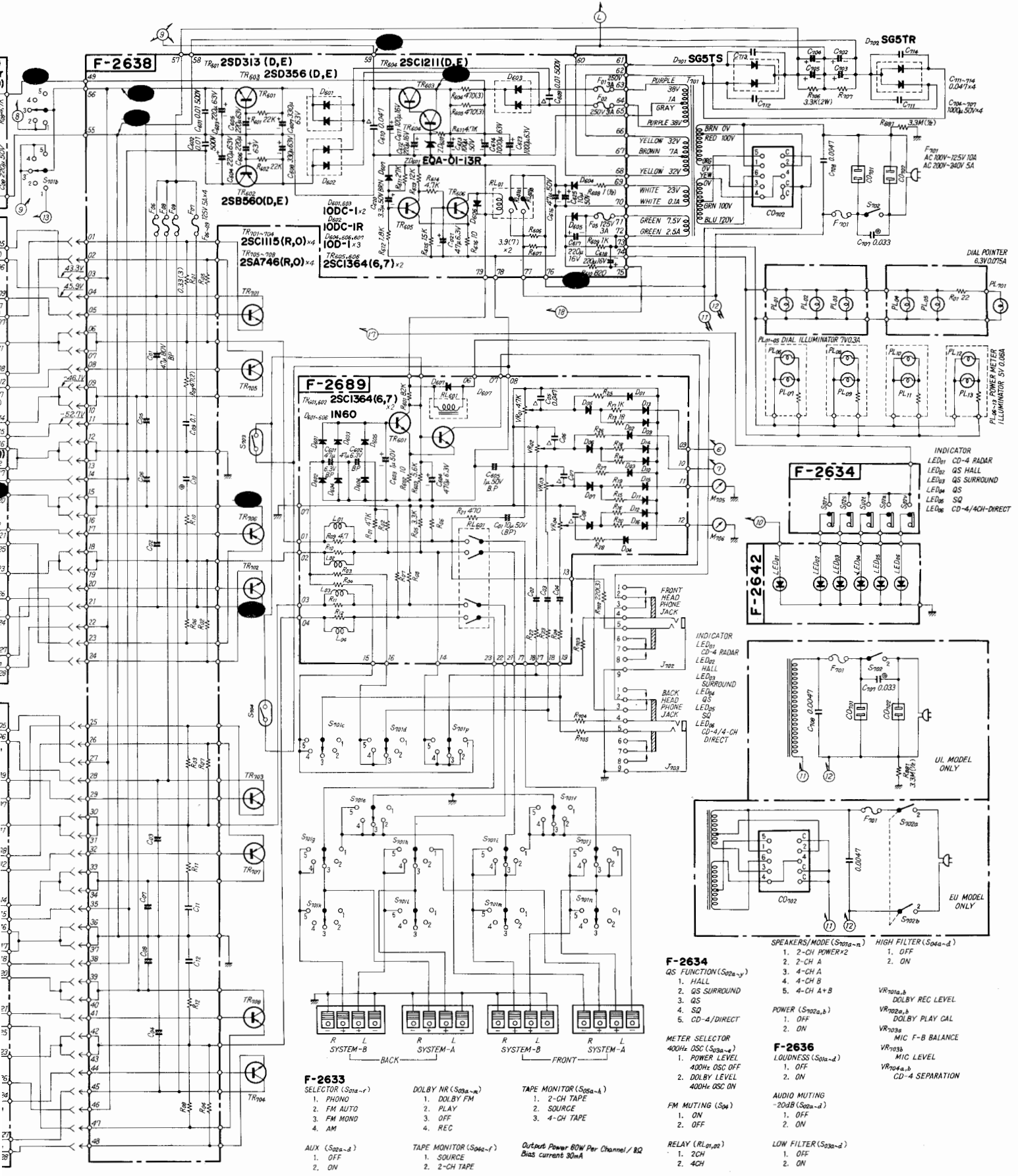

**F-2633**  
 SELECTOR (S101-f)  
 1. PHONO  
 2. FM AUTO  
 3. FM MONO  
 4. AM

**DOLBY NR (S101-n)**  
 1. DOLBY FM  
 2. PLAY  
 3. OFF  
 4. REC

**TAPE MONITOR (S101-a)**  
 1. 2-CH TAPE  
 2. SOURCE  
 3. 4-CH TAPE

**F-2634**  
 QS FUNCTION (S101-y)  
 1. HALL  
 2. QS SURROUND  
 3. QS  
 4. SQ  
 5. CD-4/DIRECT

**METER SELECTOR**  
 400Hz OSC (S101-a)  
 1. POWER LEVEL  
 400Hz OSC OFF  
 2. DOLBY LEVEL  
 400Hz OSC ON

**POWER (S101-b)**  
 1. OFF  
 2. ON

**F-2636**  
 LOUDNESS (S101-a)  
 1. OFF  
 2. ON

**AUDIO MUTING**  
 -20dB (S101-d)  
 1. OFF  
 2. ON

**RELAY (RL101)**  
 1. 2CH  
 2. 4CH

**LOW FILTER (S101-d)**  
 1. OFF  
 2. ON



### 7-5. QRX-8001/9001 4-Channel Section

\* La présentation et les spécifications sont susceptibles d'être modifiées sans préavis.  
 \* Änderungen, die dem technischen Fortschritt entsprechen, vorbehalten.  
 \* Design and specification subject to change without notice.

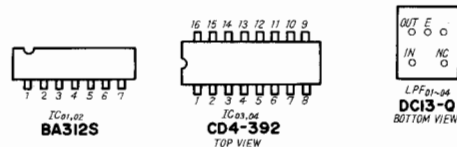
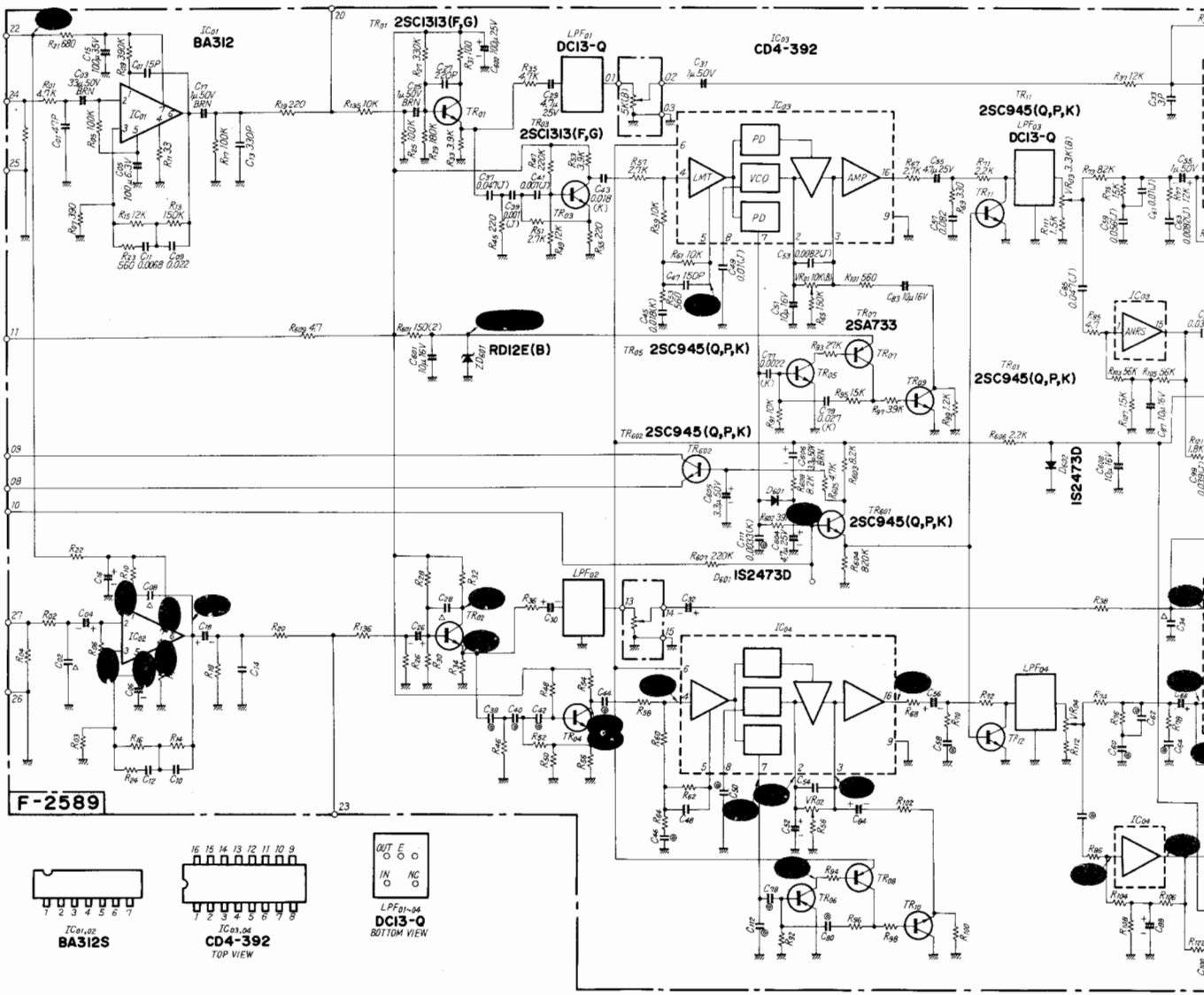
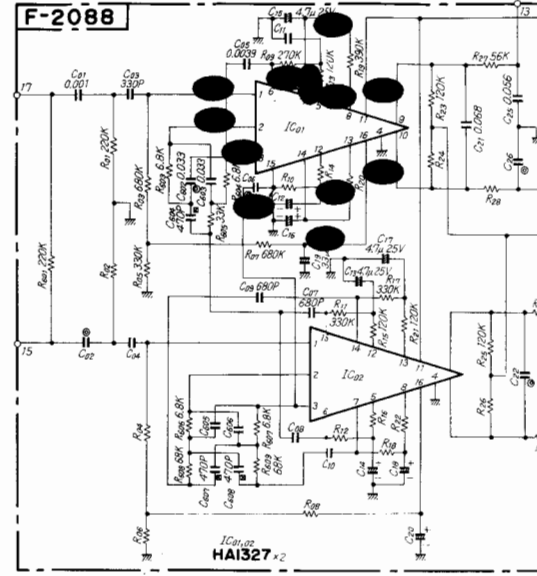
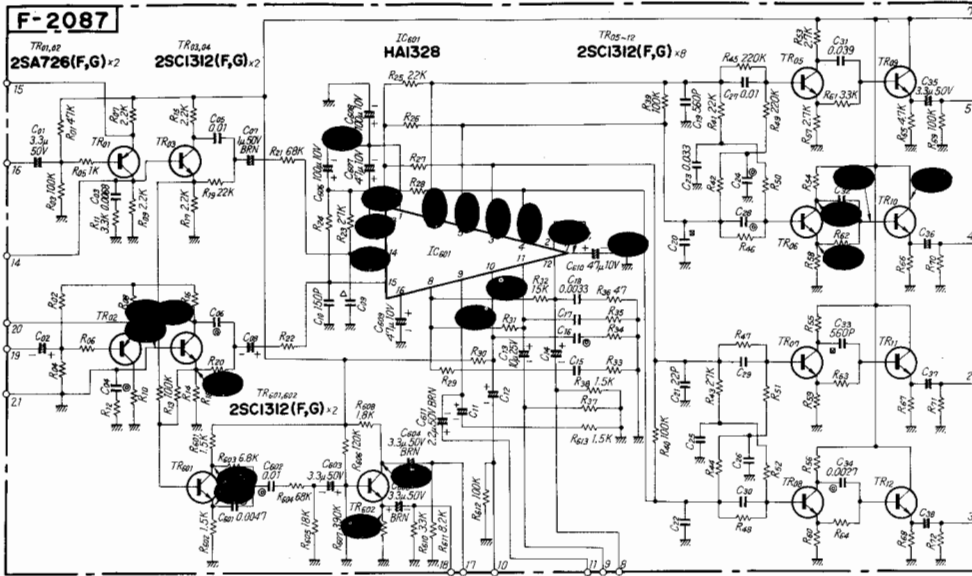

présentation et les spécifications sont susceptibles d'être modifiées sans préavis par suite d'améliorations éventuelles.  
 Änderungen, die dem technischen Fortschritt dienen, bleiben vorbehalten.  
 Design and specification subject to change without notice for improvements.

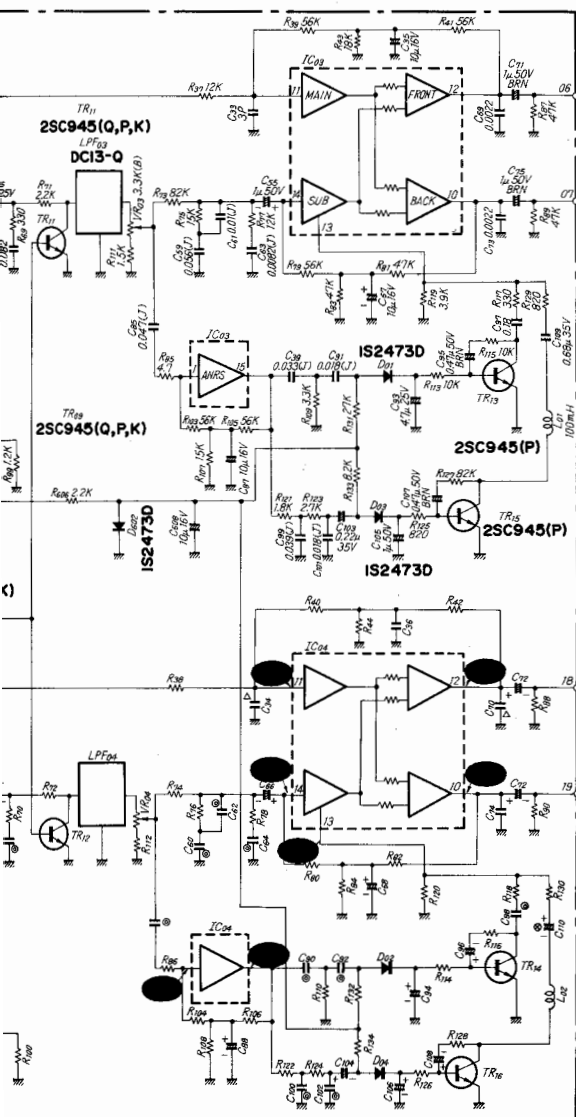
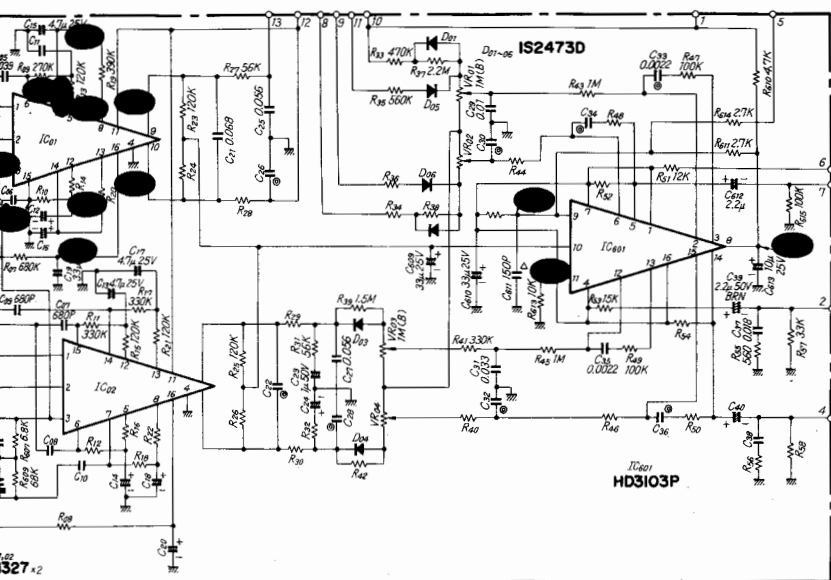

- |  |                   |  |  |
|--|-------------------|--|--|
| 2SA733<br>2SB560<br>2SC945<br>2SC1047<br>2SC1222<br>2SC1364<br>2SC1674 | 2SC1636-1         | 2SC984   | 2SA128<br>2SA726<br>2SC711<br>2SC738<br>2SC1211<br>2SC1312<br>2SC1313<br>2SC1708 |
|  |                   |  |  |
| 2SB536<br>2SD313<br>2SD381   | 2SD356            |  | 2SA746<br>2SB611<br>2SC1115<br>2SC1444<br>2SD581                                 |
|  |                   |  |  |
| 3SK41  | 2SA899<br>2SC1904 | BA 312   | PC555H   |
|  |                   |  |  |
| 2SC733<br>2SC735   | HA 1151           | HA 1196 HA 1137W<br>HA 1197 CD4392<br>HA 1327 HD3103PB<br>HA 1328 NE545B |  |
|  |                   |  |  |
| 1N34A<br>1N60  | 10DC 1            | 10D 1  | RD12EB<br>RD13EB<br>RD62E<br>EQA01-06R<br>EQA01-13R<br>EQA01-24R                 |
|  |                   |  |  |
| VD1212   | IS2473D<br>1S1588 | 10DC-1R  |  |
|  |                   |  |  |
| SG5TS  | SG5TR             |  |  |
|  |                   |  |  |

## 8. THREADING OF DIAL CORD

\*If a dial cord is cut off or slips, replace it by following procedures.

As this units use 0.6mm $\phi$  cord, please replace it with the same type certainly.

\*The length of dial cord is approximately 190cm (74 inch).

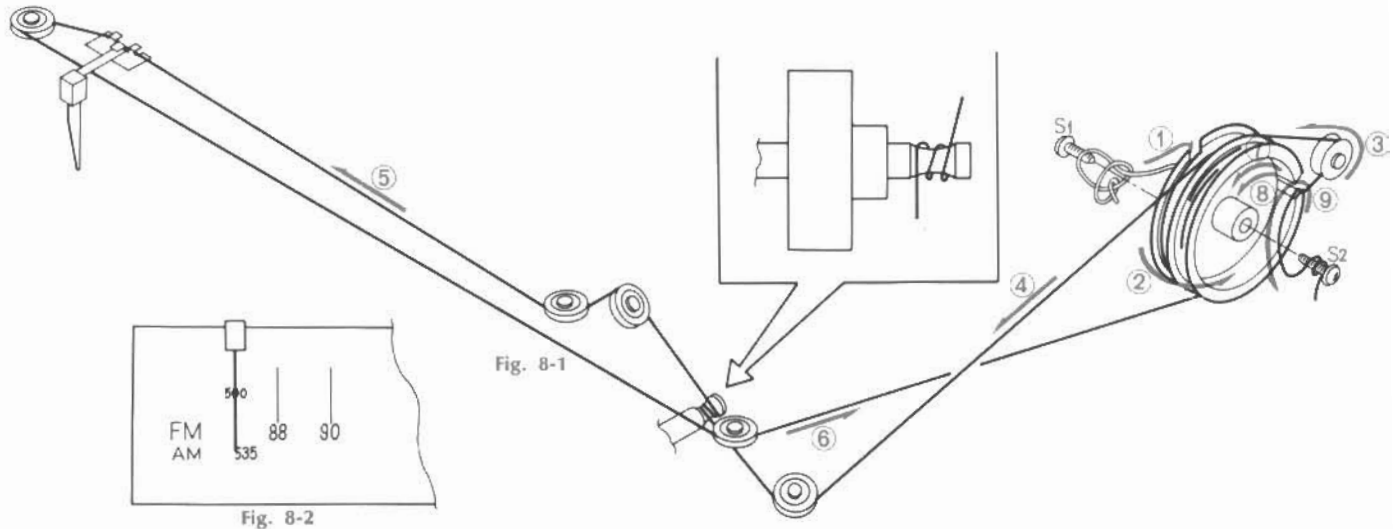

### 8-1. Threading of Dial Cord

Thread the dial cord in numerical order from ① to ⑨ as Fig. 8-1.

- 1) Close the variable capacitor completely (Max. capacitance).
- 2) Tie dial cord to the screw, S1 of the dial pulley.
- 3) Thread cord in the direction of arrow from ① to ⑨
- 4) After ⑨, tie the cord to the screw S2 of the dial pulley.

### 8-2. Attachment of Dial Pointer

- 1) Close the variable capacitor completely.
- 2) Set the dial pointer as Fig. 8-2.

\*Confirm that the dial pointer runs smoothly on the dial scale by turning the tuning shaft.

Stock No.	Description
6036050	Dial Cord (0.6mm $\phi$ )
6146670	44 Type Pulley

---

## 9. PACKING LIST

Parts No.	Stock No.	Description
1	9116631	Vinyl Cover
2	9028010	Stylofoam Packing
3	{ 9009290	Carton Case (MODEL QRX-8001)
	{ 9009280	Carton Case (MODEL QRX-9001)
4	5996080	Curl Stopper

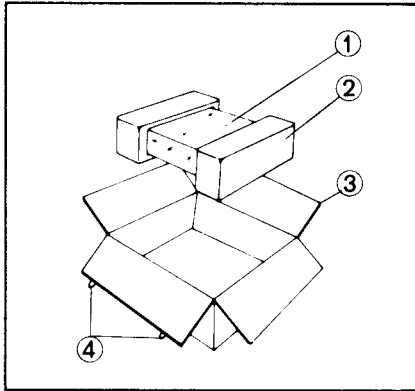

---

## 10. ACCESSORY PARTS LIST

Stock No.	Description
9202400	Operating Instructions (MODEL QRX-8001)
9202410	Operating Instructions (MODEL QRX-9001)
9237440	Schematic Diagram (MODEL QRX-8001)
9237430	Schematic Diagram (MODEL QRX-9001)
9416010	CD-4 Adjustng Record (MODEL QRX-9001)

---

**Sansui**

SANSUI ELECTRIC CO., LTD.

14-1 Izumi 2-Chome, Suginami-ku, TOKYO 168 JAPAN  
TELEPHONE: (03) 323-1111/TELEX. 232-2076