

SERVICE MANUAL

QUARTZ PLL SYNTHESIZER RECEIVER

SANSUI R-707/707L

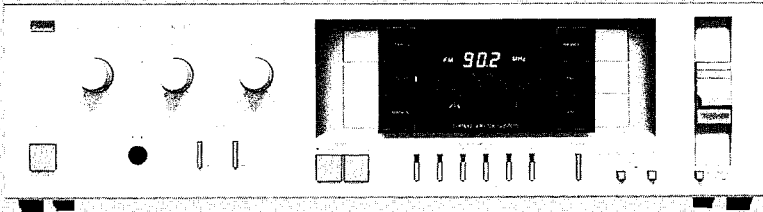

SANSUI ELECTRIC CO., LTD.

● SPECIFICATIONS

● R-707

Audio section

Power output

Min. RMS, both channels driven, from 30 to 20,000 Hz with no more than 0.06 % total harmonic distortion
50 watts per channel into 8 ohms

Total harmonic distortion

..... less than 0.06 % at or below rated min. RMS power output

Frequency response (at 1 watt)

..... 10 to 50,000 Hz, +1 dB, -2 dB

Input sensitivity and impedance (at 1 kHz)

PHONO 2.5 mV/47 kilohms

TAPE PLAY 150 mV/47 kilohms

Signal to noise ratio (short-circuit, A-network)

PHONO 72 dB

TAPE PLAY 90 dB

FM section

Tuning range 88 to 108 MHz

Usable sensitivity

Mono IHF 10.8 dBf (1.9 μ V)

DIN 0.9 μ V

50 dB quieting sensitivity

Stereo 37 dBf

Signal to noise ratio (at 65 dBf)

Stereo 65 dB

Distortion (at 65 dBf)

Stereo less than 0.25 % at 1,000 Hz

Stereo separation 40 dB at 1,000 Hz

AM section

Tuning range 530 to 1,600 kHz

Usable sensitivity 54 dB/m (501 μ V/m)

Signal to noise ratio 45 dB

Others

Power voltage 120/220/240 V (50/60 Hz)

For U.S.A. and Canada

..... 120 V (60 Hz)

Power consumption 190 watts 240 VA Rated

290 watts Maximum

Dimensions 430 mm (16-15/16") W

118 mm (4-11/16") H

240 mm (9-1/2") D

Weight 5.4 kg (11.9 lbs.) net

6.2 kg (13.7 lbs.) packed

● R-707L

Audio section

Power output

Min. RMS, both channels driven, from 30 to 20,000 Hz with no more than 0.06 % total harmonic distortion
50 watts per channel into 8 ohms

Total harmonic distortion

..... less than 0.06 % at or below rated min. RMS power output

Frequency response (at 1 watt)

..... 10 to 50,000 Hz, +1 dB, -2 dB

Input sensitivity and impedance (at 1 kHz)

PHONO 2.5 mV/47 kilohms

TAPE PLAY 150 mV/47 kilohms

Signal to noise ratio (short-circuit, A-network)

PHONO 72 dB

TAPE PLAY 90 dB

FM section

Tuning range 88 to 108 MHz

Usable sensitivity

Mono IHF 10.8 dBf (1.9 μ V)

DIN 0.9 μ V

50 dB quieting sensitivity

Stereo 37 dBf

Signal to noise ratio (at 65 dBf)

Stereo 65 dB

Distortion (at 65 dBf)

Stereo less than 0.25 % at 1,000 Hz

Stereo separation 40 dB at 1,000 Hz

AM section

Tuning range MW: 530 to 1,600 kHz

LW: 153 to 360 kHz

Usable sensitivity MW: 54 dB/m (501 μ V/m)

LW: 63 dB/m

Signal to noise ratio 45 dB

Others

Power voltage 220/240 V (50/60 Hz)

Power consumption 290 watts

Dimensions 430 mm (16-15/16") W

118 mm (4-11/16") H

240 mm (9-1/2") D

Weight 5.4 kg (11.9 lbs.) net

6.2 kg (13.7 lbs.) packed

* Design and specifications subject to change without notice for improvements.

1. BLOCK DIAGRAM

1-1. Tuner Section

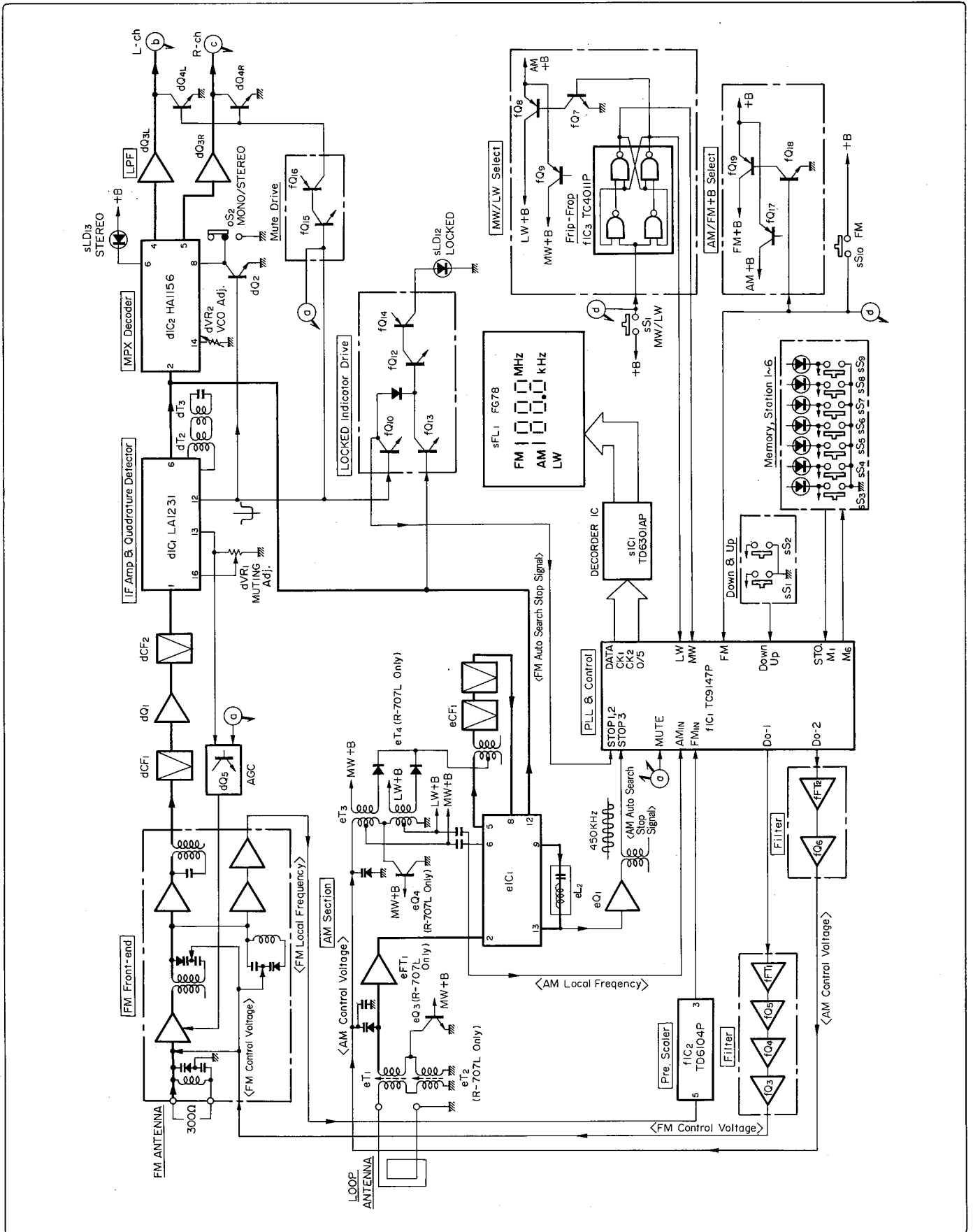

1-2. Audio Section

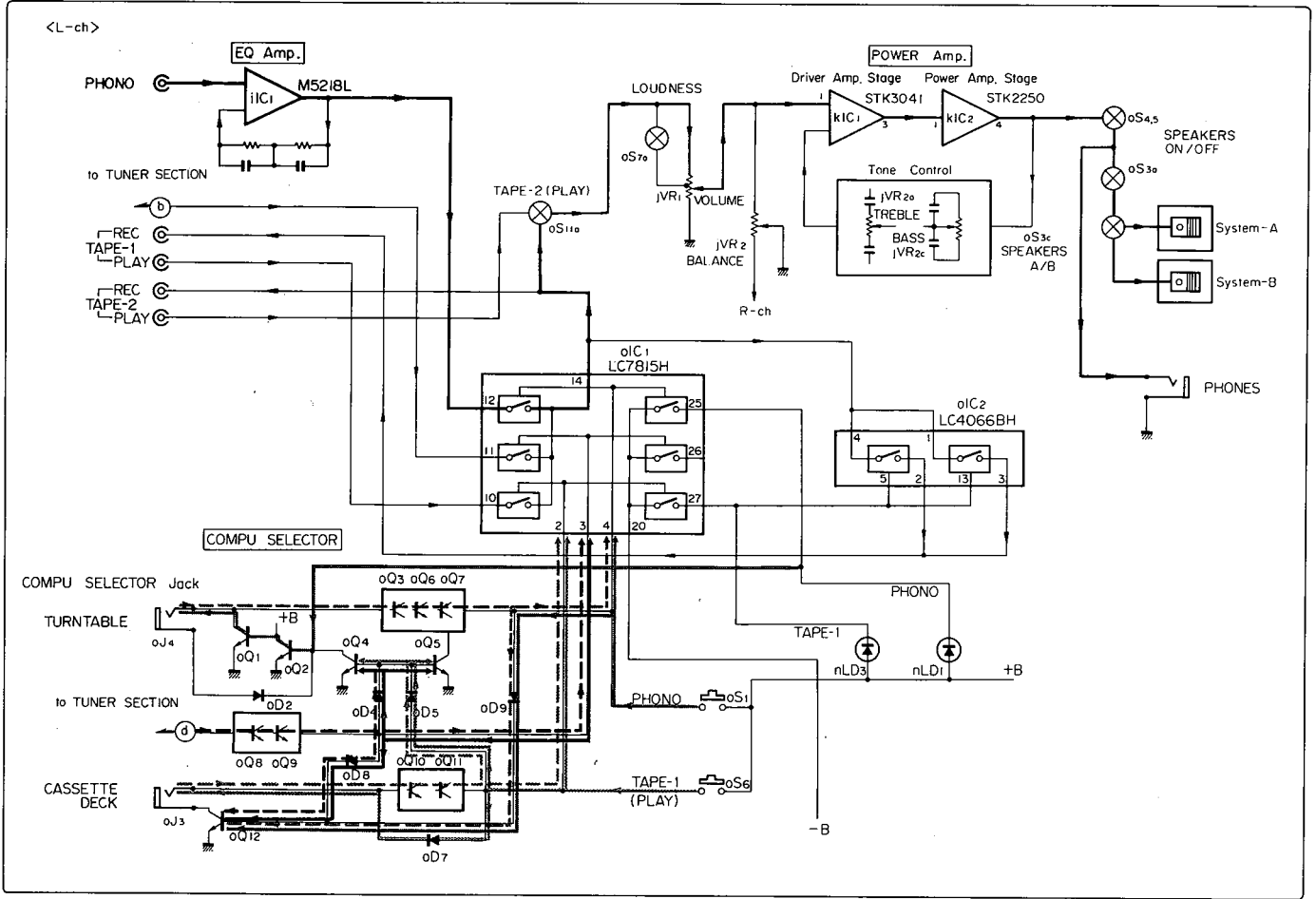

● LC7815H Analog Function Switch IC

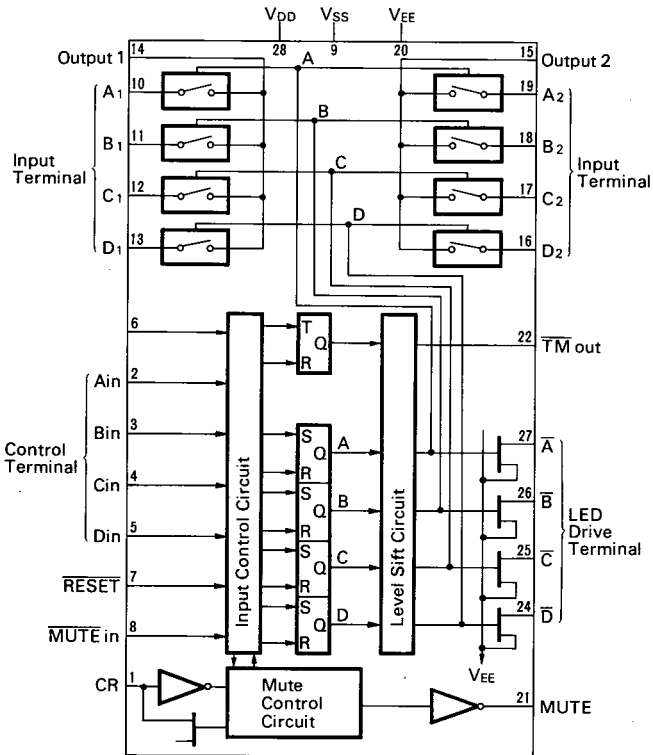

● LC4066BH Quad Bilateral Switch IC

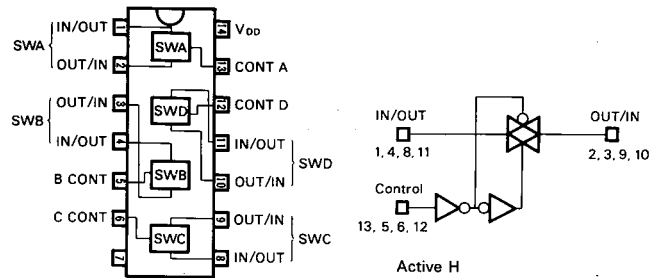

* LC7815H

Condition of control input terminals Port (Pin No.)				Connected input terminal to output 1 and 2 terminals	Connected terminal to LED indicator
Ain (2)	Bin (3)	Cin (4)	Din (5)	PORT (Pin No.)	PORT (Pin No.)
H	×	×	×	A ₁ (10)	A ₂ (19)
L	H	×	×	B ₁ (11)	B ₂ (18)
L	L	H	×	C ₁ (12)	C ₂ (17)
L	L	L	H	D ₁ (13)	D ₂ (16)

H : H level L : L level × : Don't care

2. OPERATION OF COMPU SELECTOR

* This receiver has COMPU SELECTOR function which works with a turntable (P-D30, P-L40 or P-L50), a tape deck (D-77F, D-77R or D-99D).

A. Operation when one of the input selector switches of the receiver is pushed

- When the PHONO switch is pushed, input selector is automatically set to PHONO, the platter of the turntable (P-L40 or P-L50) starts rotating and the tonearm automatically moves to play record.
- When the FM, the AM (MW/LW) or TAPE-1 switch is pushed during record play, the tonearm returns to the arm rest and the platter stops, rotating automatically.

- When the TAPE-1 switch is pushed, input selector is automatically set to TAPE-1, the cassette deck (D-77F or D-77R) starts automatically to playback a tape.
- When the PHONO, the FM or the AM (MW/LW) switch is pushed during tape playback, cassette deck stops automatically.

B. Operation when one of the function switches of combined unit is controlled

- When the START/STOP switch of the turntable (P-D30, P-L40 or P-L50) is pushed, the input selector of the receiver is automatically set to the PHONO mode.
- When the PLAY switch of the cassette deck is pushed, the input selector of the receiver is automatically set to the TAPE-1 mode.

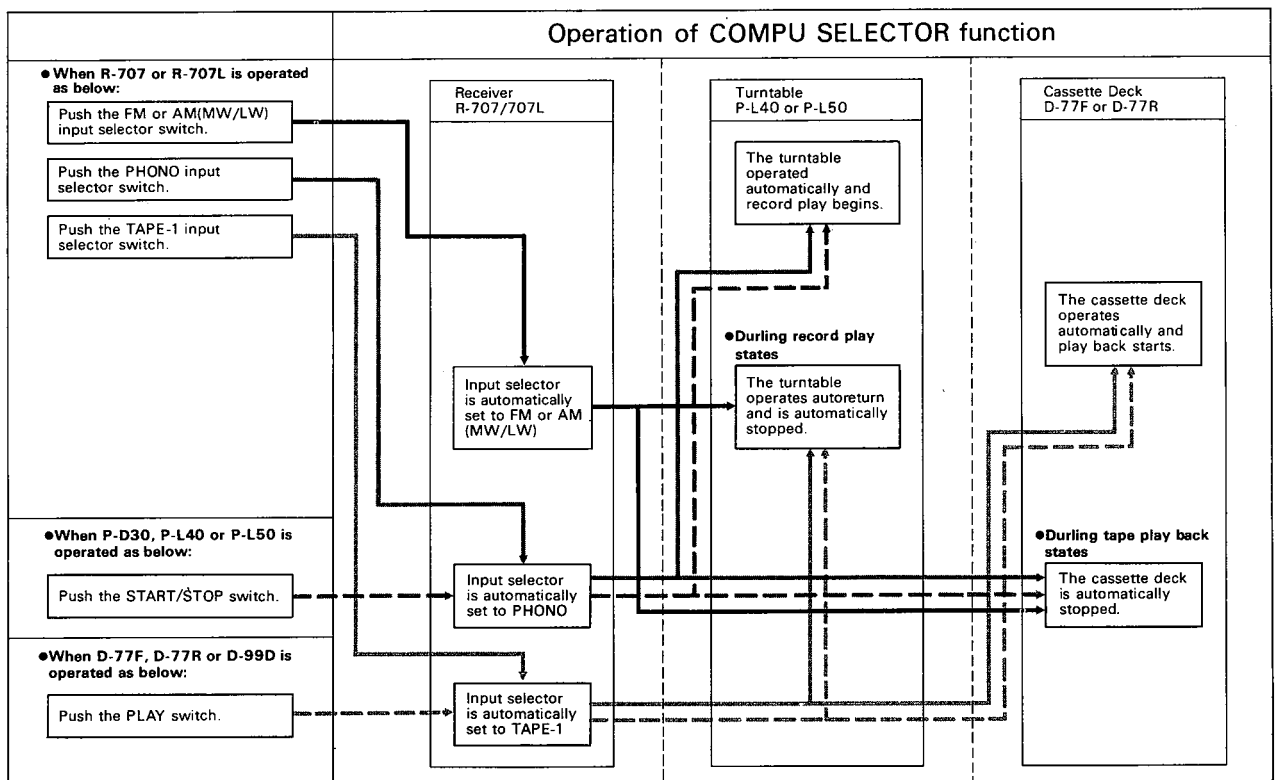

3. ADJUSTMENTS

◆ ADJUSTMENT FOR FM

- There are two kind in indication FM SSG output attenuator
 - Attenuator with marking of 75Ω open open indication type.
 - Attenuator with marking of 75Ω load or close load or close indication type.
- FM SSG output level in this FM adjustment are described as open indication type.
- To feed FM signal, a dummy antenna circuit as Fig. 2-2 must be connected between FM SSG output and ANT terminal (300Ω) of the unit.

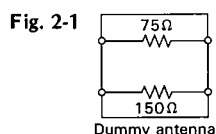

- The following table shows relations among FM SSG attenuator indication (dB), available power ratio (dBf) and antenna terminal voltage (dB/μV) in each indication type.

	FM SSG Attenuator Indication	Available Power Ratio	Antenna Terminal Voltage
Open indication type	0 dB	-0.8 dBf	-6 dB/μV
	66 dB	65.2 dBf	60 dB/μV
Load or close indication type	0 dB	5.2 dBf	0 dB/μV
	60 dB	65.2 dBf	60 dB/μV

3-1. FM Adjustment (See Top View on Page 12)

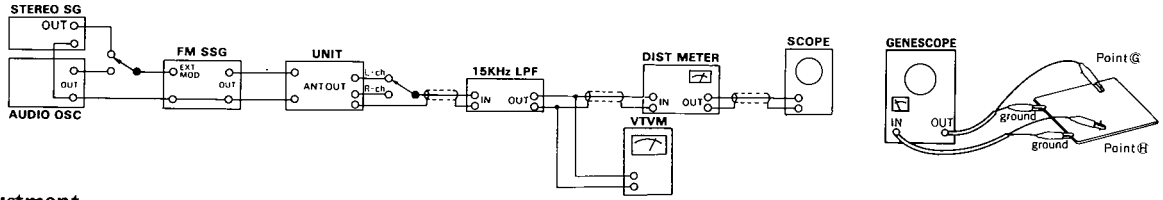

1) FM IF, Adjustment

- Note: 1. SELECTOR FM
 2. FM MUTING/MODE OFF/MONO

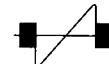
STEP	SUBJECT	FEED SIGNAL		MEASURE OUTPUT	ADJUST	ADJUST FOR	REMARKS
		FROM	TO				
1.	Reference Frequency Adj.	No Input	—	Between Point (A) (Pin 24 of fIC1) & Earth Freq. counter • See Parts Location F-3893 on Page 7.	FTC1 (F-3893)	25 kHz	• Short between Point (B) & Point (C) (Pin 36 & 42 of fIC1)
2.	IF Coil Adj.	98MHz ANT Input 20dBf (14.8dB), 1kHz (100% MOD.), FM SSG	ANT terminal 300Ω	Between Point (D) (dVR1, F-3862) & DC Volt Meter • See Parts Location F-3862 on Page 6.	IFT Coil (Front-end)	Max. DC Volt	
3.	Discriminator Coil Adj. In case of using Genescope	1	No Input	Between Point (E) & Point (F) (Across dR41, F-3767) DC Volt Meter • See Parts Location F-3767 on Page 8	dT2 (F-3767)	DC 0V	• Repeat procedures as stated in subject 1 & 2. 
		2	Output 80dB, Genescope	Point (G)	Between Point (H) (dD2) & Earth • See Parts Location F-3767 on Page 8	dT3 (F-3767)	
	Discriminator Coil Adj. In case of using Dist meter	1	No Input	Between Point (E) & Point (F) (Across dR41, F-3767) DC Volt Meter • See Parts Location F-3767 on Page 8	dT2 (F-3767)	DC 0V	• Repeat procedures as stated in subject 1 & 2. • Since the dT1 has already adjusted, perform only a fine adjustment in this procedure.
		2	98MHz ANT Input 65dBf (59.8dB), 1kHz (100% MOD.), FM SSG	ANT terminal 300Ω	• REC OUT L-CH or R-CH VTVM & SCOPE	dT3, (F-3767)	

2) FM STEREO Adjustment

- Note: 1. SELECTOR FM
 2. FM MUTING/MODE ON/AUTO

STEP	SUBJECT	FEED SIGNAL		MEASURE OUTPUT	ADJUST	ADJUST FOR	REMARKS
		FROM	TO				
1.	PLL VCO Adj.	98MHz ANT Input 65dBf (59.8dB), FM SSG, Pilot 19kHz (9% MOD.), R or L MODE 1kHz + Pilot (100% MOD.), STEREO SG	ANT terminal 300Ω	Stereo indicator	dVR2 (F-3767)	Light indicator	Adjust the dVR2 within center of lighting level
	PLL VCO Adj. In case of using Freq. counter	98MHz ANT Input 65dBf (59.8dB), FM SSG, No MOD.	Same as above	Between Point (I) (Pin 10 of dIC2) & Earth, Freq. counter • See Parts Location F-3767 on Page 8	dVR2 (F-3767)	19kHz ± 50Hz	
2.	Muting level Adj.	98MHz ANT Input 22dBf (16.8dB), FM SSG Pilot 19kHz (9% MOD.), L or R MODE 1kHz + Pilot (100% MOD.), STEREO SG.	Same as above	Stereo indicator or OUTPUT L-CH or R-CH VTVM & SCOPE	dVR1 (F-3862)	Output Signal comes out.	

3-2. AM Adjustment (See Parts Location F-3862 on Page 6 and Top View on Page 12)

Note: SELECTOR AM (MW)

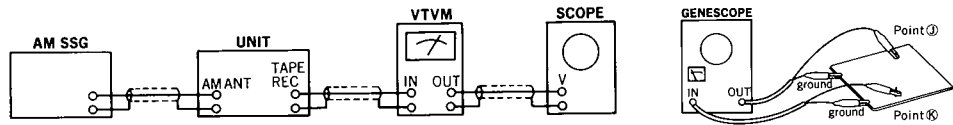

(1) AM IF, RF Adjustment & MW (AM) Tuning Adjustment

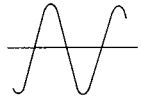
STEP	SUBJECT	FEED SIGNAL		MEASURE OUTPUT	ADJUST	ADJUST FOR	REMARKS
		FROM	TO				
1.	IF Coil Adj.	Genescope Output 60dB	Point ① (eTC2, F-3862)	Between Point ② (eR26) & Earth • See Parts Location F-3862 on Page 6	eCF1, eL2 (F-3746)	Max. Waveform	
2.	522kHz (or 520kHz) Tuning Adj.	No Input	—	Between Point ③ (eR1, F-3862) & Earth DC Volt Meter	eT3 (F-3862)	1V	Before adjustments of step 2 and 3, tune the upper (1710kHz), lower (522kHz) band edge frequency as below procedure.
3.	1710kHz Tuning Adj.	No Input	—	Same as above	eTC2 (F-3862)	9V	
4.	603kHz (or 600kHz) RF Adj.	603kHz (or 600kHz) ANT Input 30dB 400Hz (30% MOD.), AM SSG	ANT terminal	REC OUT L-CH or R-CH VTVM & Scope	eT1 (F-3862)	Max. Output	
5.	1404kHz (or 1400kHz) RF Adj.	1400kHz (or 1400kHz) ANT Input 30dB 400Hz (30% MOD.), AM SSG	Same as above	REC OUT L-CH or R-CH VTVM & Scope	eTC1 (F-3862)	Max. Output	

(2) LW Tuning Adjustment (R-707L Only)

Note: SELECTOR LW (R-707L)

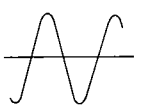
STEP	SUBJECT	FEED SIGNAL		MEASURE OUTPUT	ADJUST	ADJUST FOR	REMARKS
		FROM	TO				
1.	153kHz Tuning Adj.	No Input	—	Between Point ④ (eR1, F-3862) & Earth DC Volt Meter	eT4 (F-3862)	1V	
2.	360kHz Tuning Adj.	No Input	—	Same as above	eTC4 (F-3862)	9V	
3.	170kHz RF Adj.	170kHz ANT Input 30dB 400Hz (30% MOD.), AM SSG	ANT terminal	REC OUT L-CH or R-CH VTVM & Scope	eT2 (F-3862)	Max. Output	
4.	300kHz RF Adj.	300kHz ANT Input 30dB 400Hz (30% MOD.) AM SSG	Same as above	REC OUT L-CH or R-CH VTVM & Scope	eTC3 (F-3862)	Max. Output	

•Abbreviations

Equipment		Others	
AM FM Generator Oscilloscope	Genescope	Antenna	ANT.
AM Standard Signal Generator	AM SSG	Modulation	MOD.
FM Standard Signal Generator	FM SSG	Total Harmonic Distortion	T.H.D.
FM Stereo Generator	Stereo SG		
Oscilloscope	Scope		
Audio Oscillator	Audio Osc.		
Distortion Meter	Dist. Meter		

4. PARTS LOCATION & PARTS LIST

•Since some of capacitors and resistors are omitted from parts lists in this Service Manual, refer to the Common Parts List for capacitors & resistors, which was appended previously to Sansui Manual.

4-1. F-3729 Power Amp. & Power Supply Circuit Board (Stock No. 00710001)

Component Side

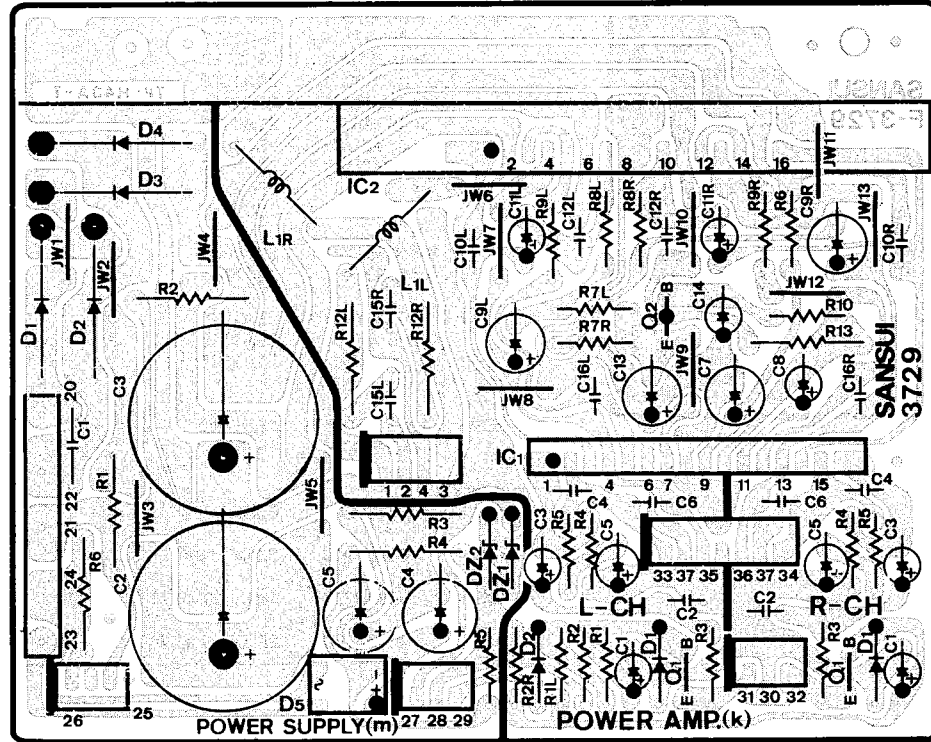

Parts List

Parts No.	Stock No.	Description	Parts No.	Stock No.	Description
•Transistor					
kQ1	46367301	2SC2458	mD1	03115300	30D2
	or 46367101	2SC2603	mD2	03115300	30D2
	or 46391901	2SC2785	mD3	03115300	30D2
kQ2	03010901	2SA992	mD4	03115300	30D2
•IC					
kIC1	46395100	STK3041	mD5	46273600	DBB10-B
kIC2	46395000	STK2250	•Zener Diode		
•Diode					
kD1, 2	03117600	1S2473D	mDZ1	46113800	05Z12
	or 46086000	1S1588	mDZ2	46113800	05Z12
kR6	46229000	100Ω 1/2W N.I.R.	•Resistor		
kR9	46229400	220Ω 1/2W N.I.R.	mR1	46251400	5.6kΩ 1W N.I.R.
kR12	46247700	4.7Ω 1W N.I.R.	mR2	46251400	5.6kΩ 1W N.I.R.
kR13	46250900	2.2kΩ 1W N.I.R.	mR3	46249800	270Ω 1W N.I.R.
kC2, 4	46137200	220pF 50V C.C.	mR4	46249800	270Ω 1W N.I.R.
kC16	07216300	0.027μF 25V C.C.	mC1, 21	08680400	10000pF 500V C.C.
kL1	46394500, 1	Inductor Coil, Filter	mC2	46395200	4700μF 50V E.C.
			mC3	46395200	4700μF 50V E.C.

•Abbreviations

C.R. : Carbon Resistor	E.B. : Bi-Polar Electrolytic Capacitor
S.R. : Solid Resistor	E.BL. : Low Leak Bi-Polar Electrolytic Capacitor
Ce.R. : Cement Resistor	Ta.C. : Tantalum Capacitor
M.R. : Metal Film Resistor	F.C. : Film Capacitor
F.R. : Fusing Resistor	M.P. : Metalized Paper Capacitor
N.I.R. : Non-Inflammable Resistor	P.C. : Polystyrene Capacitor
C.C. : Ceramic Capacitor	G.C. : Gimmic Capacitor
C.T. : Ceramic Capacitor, Temperature Compensation	V.R. : Variable Resistor
E.C. : Electrolytic Capacitor	S.V.R. : Semi Variable Resistor
E.L. : Low Leak Electrolytic Capacitor	SW. : Switch

4-2. F-3862 FM, AM RF & Preset Circuit Board (Stock No. 00709001 = R-707/00709005 = R-707L)

Component Side

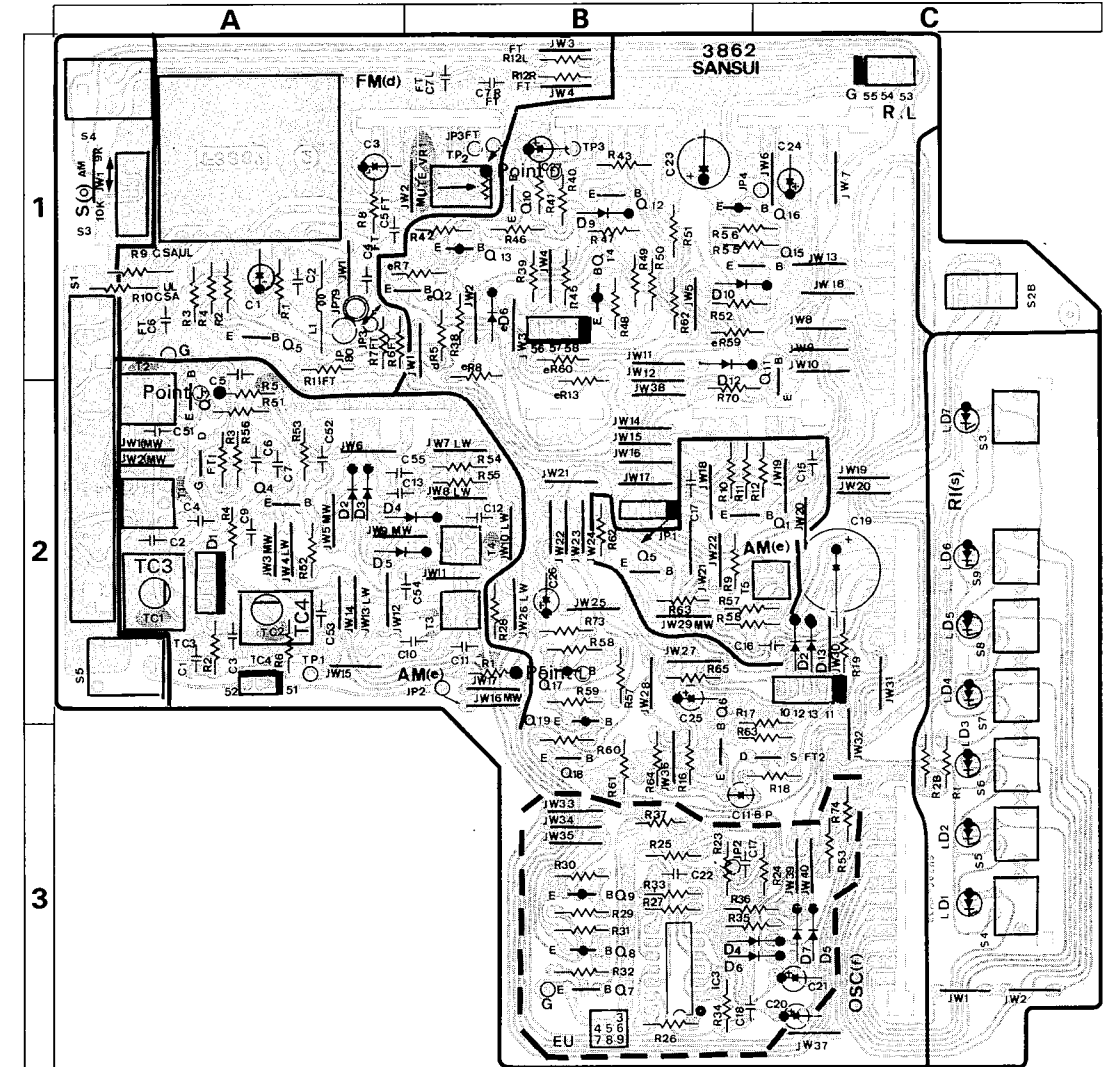

Parts List

Parts No.	Stock No.	Description	Parts No.	Stock No.	Description
dZ1	46170000	FM Frontend Pack	•Trimmer Capacitor		
•Transistor			eTC1, 2	46095600	20pF (R-707)
dQ5	46367301	2SC2458	eTC3, 4	46370700	16pF (R-707L)
	or 46367101	2SC2603	•Coil		
	or 46391901	2SC2785	eT1	46394600	AM RF Coil
•Diode			eT2	46397900	AM RF Coil (R-707L)
dD1, 2	03111600	1S2473D	eT3	46398200	AM RF Coil
	or 03111800	1S1588	eT4	46398000	AM RF Coil (R-707L)
dL1	07250300	Peaking Coil 2.2μH	eT5	46413600	AM IF Coil
dVR1	10370700	10kΩ (B) SVR, mute adj.	•Transistor		
•Transistor			fQ6, 7	46367301	2SC2458
eQ1	46393201	2SC2786		or 46367101	2SC2603
eQ2	46367301	2SC2458		or 46391901	2SC2785
	or 46367101	2SC2603	fQ8, 9	46367201	2SA1048
	or 46391901	2SC2785		or 46367001	2SA1115
eQ3, 4	46118801	2SC2878		or 46392001	2SA1175
eQ5	46391901	2SC2785	fQ10~12	46367301	2SC2458
•FET				or 46367101	2SC2603
eFT1	46393000, 1	2SK192A-Y, GR		or 46391901	2SC2785
•Varactor Diode			fQ13, 14	46367201	2SA1048
eD1	46146300	KV1236Z		or 46367001	2SA1115
•Diode				or 46392001	2SA1175
eD2~6	46086000	1S1588			
	or 03117600	1S2473D			
eR64	46229000	100Ω 1/2W N.I.R.			

to be continued▶

Parts List <F-3862>

Parts No.	Stock No.	Description
fQ15	46367301	2SC2458
	or 46367101	2SC2603
	or 46391901	2SC2785
fQ16, 17, 19	46367201	2SA1048
	or 46367001	2SA1115
	or 46392001	2SA1175
fQ18	46367301	2SC2458
	or 46367101	2SC2603
	or 46391901	2SC2785
•FET		
fFT2	03703001, 2	2SK117-Y, GR
	or 03703401, 2	2SK163-K2, L1
•IC		
fIC3	03604100	TC4011P

Parts No.	Stock No.	Description
•Diode		
fD4~7	03117600	1S2473D
	or 46086000	1S1588
fD9, 10,	03117600	1S2473D
fD12	or 46086000	1S1588
fD13, 15	03117600	1S2473D
	or 46086000	1S1588
•Capacitor		
fC11	08451900	3.3μF 50V E.B.
fC19	46462600	3900μF 6.3V E.L.
fR73	46229000	100Ω 1/2W N.I.R.
oS2	46361000	Push SW., FM MUTING/MODE
oS6	46177200	Slide SW., AM STEP (R-707)
	46364200	4P Antenna Terminal
sLD1~6	07250900	LED TLG-123
sS3~9	46395900	Push SW., MEMORY, FM/AM PRESET

4-3. F-3893 Control Circuit Board (Stock No. 00709401)

Component Side

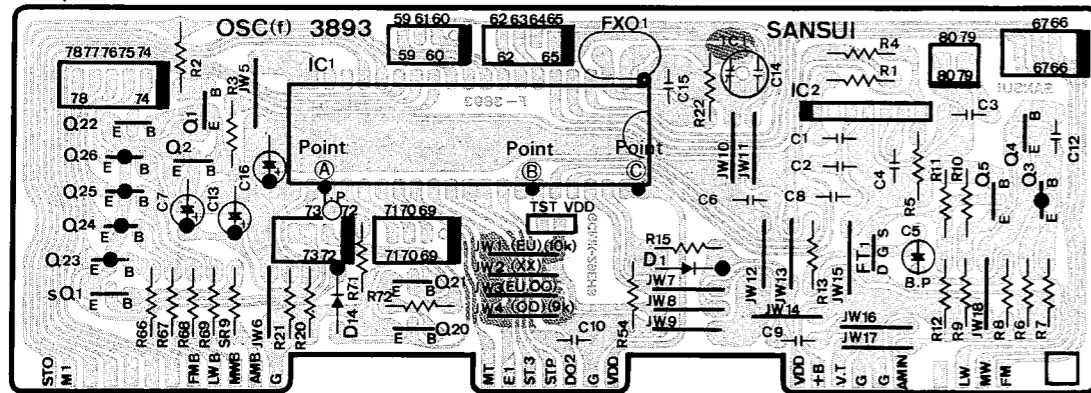

Parts List

Parts No.	Stock No.	Description
•Transistor		
fQ1, 2, 4	46367301	2SC2458
	or 46367101	2SC2603
	or 46391901	2SC2785
fQ3	46367201	2SA1048
	or 46367001	2SA1115
	or 46392001	2SA1175
fQ5	46367301	2SC2458
	or 46367101	2SC2603
	or 46391901	2SC2785
fQ20~22	46367301	2SC2458
	or 46367101	2SC2603
	or 46391901	2SC2785
fQ23~	46367201	2SA1048
fQ26	or 46367001	2SA1115
	or 46392001	2SA1175
•FET		
fFT1	03703001, 2	2SK117-Y, GR
	or 03703401, 2	2SK163-K2, L1

Parts No.	Stock No.	Description
•IC		
fIC1	46397300	TC9147P
fIC2	07225000	TD6104P
FXO1	07237700	Quartz Element
•Diode		
fD1, 2	03117600	1S2473D
	or 46086000	1S1588
fD14	03117600	1S2473D
	or 46086000	1S1588
fC5	08451700	1μF 50V E.B.
fTC1	46095800	45pF
•Transistor		
sQ1	46367301	2SC2458
	or 46367101	2SC2603
	or 46391901	2SC2785

4-4. F-3875 COMPU Selector Control Circuit Board (Stock No. 00709701)

Component Side

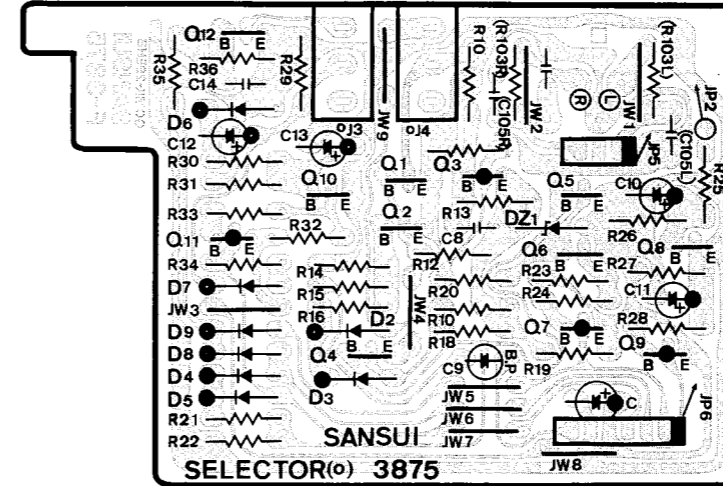

Parts List

Parts No.	Stock No.	Description
•Transistor		
oQ1, 2	46367301	2SC2458
	or 46367101	2SC2603
	or 46391901	2SC2785
oQ3, 7, 9	46367201	2SA1048
	or 46367001	2SA1115
	or 46392001	2SA1175
oQ4~6	46367301	2SC2458
	or 46367101	2SC2603
	or 46391901	2SC2785
oQ8, 10,	46367301	2SC2458
12		
	or 46367101	2SC2603
	or 46391901	2SC2785
oQ11	46367201	2SA1048
	or 46367001	2SA1115
	or 46392001	2SA1175
•Diode		
oD2~9	03117600	1S2473D
	or 46086000	1S1588
•Zener Diode		
oDZ1	46111200	05Z5.1
oC9	08450800	3.3μF 16V E.C.
oJ3, 4	46148200	Jack, COMPU SELECTOR
oZ2	46363700	2P Terminal, PHONO

4-5. F-3874 Analog Switch Circuit Board (Stock No. 00709601)

Component Side

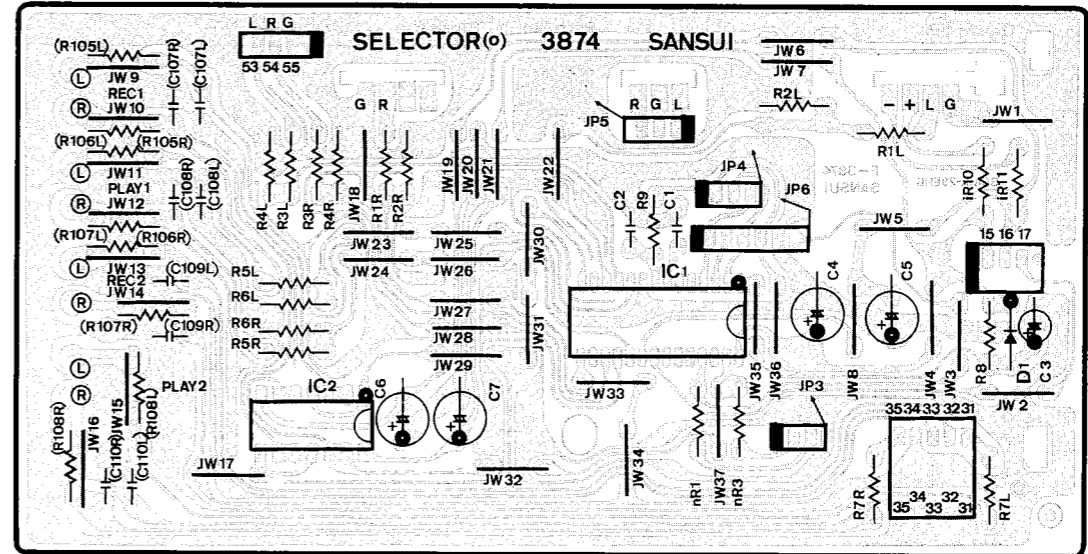

Parts List

Parts No.	Stock No.	Description
•Resistor		
iR10	46229000	100Ω 1/2W N.I.R.
iR11	46229000	100Ω 1/2W N.I.R.
nR1, 3	46230400	1.5kΩ 1/2W N.I.R.
•IC		
oIC1	46394800	LC7815H
oIC2	46255000	LC4066BH

Parts No.	Stock No.	Description
•Diode		
oD1	03117600	1S2473D
	or 46086000	1S1588
oC107~	46137600	470pF 50V C.C.
oC110		
oZ3	46363800	4P Terminal, TAPE-1
oZ4	46371500	4P Terminal, TAPE-2

4-6. F-3725 EQ. Amp. Circuit Board

Component Side

(Stock No. 00695501)

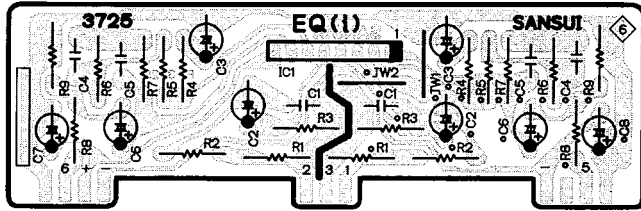

Parts List

Parts No.	Stock No.	Description
•IC		
iIC1	46078900	M5218L
iC1	46137200	220pF 50V C.C.

4-7. F-3767 FM IF Circuit Board (Stock No. 00708301)

Component Side

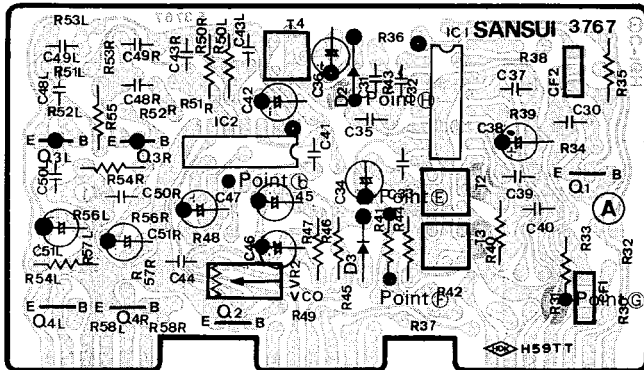

Parts List

Parts No.	Stock No.	Description
•Transistor		
dQ1	46393201	2SC2786
dQ2, 4	46391901	2SC2785
dQ3	46392001	2SA1175
•IC		
dIC1	07191200	LA1231N
dIC2	03603000	HA1156W
•Diode		
dD2	03117600	1S2473
dD3	03117600	1S2473
dC36	08451400	4.7 μ F 25V E.B.
dC42	08451200	2.2 μ F 25V E.B.
dCF1, 2	46202500	Ceramic Filter
dT2	46369100	FM IF Coil
dT3	46369200	FM IF Coil
dVR2	07218000	6.8k Ω (B) S.V.R., VCO

4-8. F-3746 AM Tuner Circuit Board

Component Side

(Stock No. 00708101)

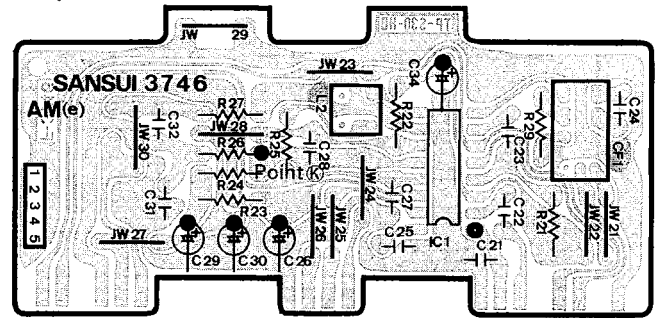

Parts List

Parts No.	Stock No.	Description
•IC		
eIC1	03603900	HA1197
eCF1	07254000	Ceramic Filter SFL450G3
eL2	46369600	AM IF Coil

* Concerning Printed Resistor and Printed Silver Pattern

In this model, printed circuit board is used on which carbon resin resistance and silver foil pattern are coated. And it is impossible to replace those parts. Therefore, please keep following procedures when repairing or ordering the parts.

1. When repairing the printed resistor, cut off center portion of the resistor to make complete open circuit. Then solder 1/3 W type carbon resistor to conductor side of the PCB.
2. When repairing the printed silver pattern, solder lead wire to conductor side of the PCB.
3. When ordering the 1/3 W type carbon resistor, read the resistance value from the schematic diagram, and refer to "Common Parts List for Resistors and Capacitors".

4-9. F-3873 Digitally Display Circuit Board (Stock No. 00709501)

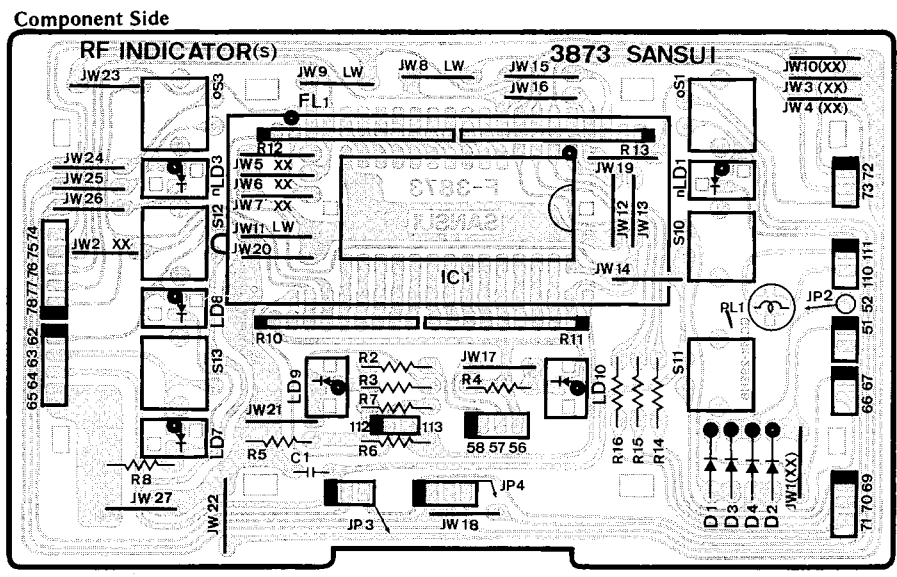

Parts List

Parts No.	Stock No.	Description
nLD1, 3	46176900	LED TLS-123
nPL1	46315900	Pilot Lamp 12V 1.5A
oS1, 6	46395900	Push SW., TAPE, PHONO
●IC		
sIC1	46410100	TD6301AP
●Diode		
sD1~4	03117600 or 46086000	1S2473D 1S1588

Parts No.	Stock No.	Description
sFL1	46335600	FG78F2, Display Tube
sLD7, 8,	46176900	LED TLS-123
sLD10	or 46470200	LED SEL2210
sLD9	07250900 or 46470300	LED TLG-123 LED SEL-2410
●Array Resistor		
sR10, 11	46045900	8-10K
sR12, 13	46049600	10-10K
sS10~13	46395900	Push SW., FM, AM, AUTO, MANU

● Note: The following circuit boards are not supplied as the assembled. However, the individual parts on the circuit boards are provided for orders.

4-10. F-3877 Volume & Loudness Control Circuit Board

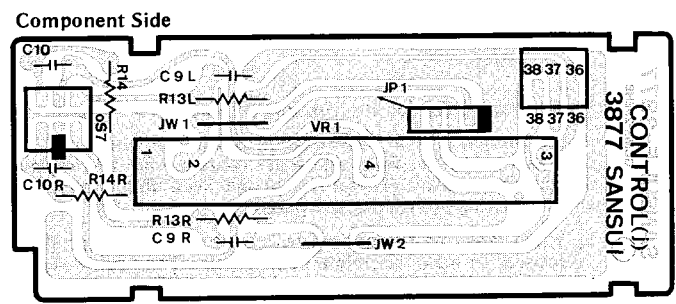

Parts List

Parts No.	Stock No.	Description
jC9	46137500	390pF 50V C.C.
jC10	07216200	0.022μF 25V C.C.
jVR1	46395300	150kΩ x 2 Slide VR, VOLUME
oS7	46360900	Push SW., LOUDNESS

4-11. F-3876 Tone & Balance VR Circuit Board

Component Side

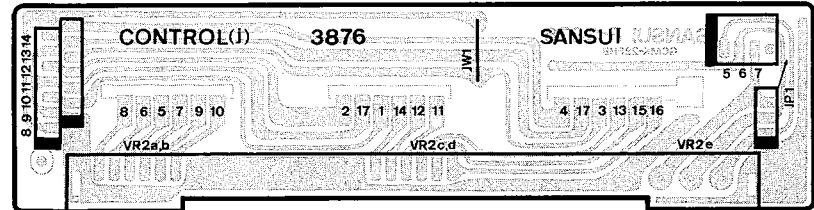

Parts List

Parts No.	Stock No.	Description
jVR2	46363100	50kΩ x 2 VR & 150kΩ

4-12. F-3726 Tone Control Circuit Board

Component Side

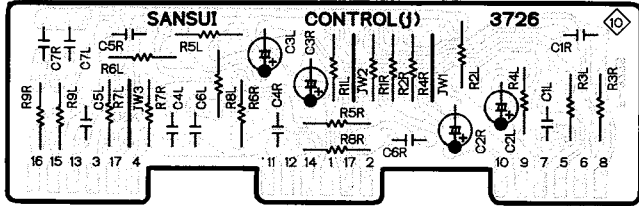

Parts List

Parts No.	Stock No.	Description
jC7	07216800	68000pF 25V C.C.

4-16. F-3887 Power Supply Circuit Board

Component Side

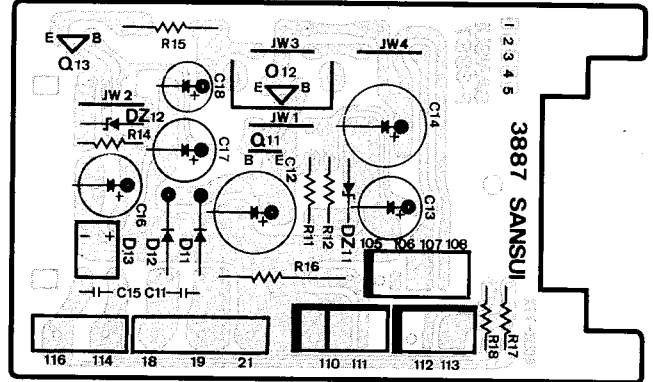

Parts List

Parts No.	Stock No.	Description
•Transistor		
mQ11	07194801	2SC1815
	or 03068301	2SC2320
	or 03059501	2SC945
	or 46367301	2SC2458
	or 46367101	2SC2603
	or 46391901	2SC2785
	mQ12, 13	03083901 2SD313AL
•Diode		
mD11, 12	03117700	10E-2
mD13	46273600	DBB10-B
•Zener Diode		
mDZ11	03159800	EQA01-14R
mDZ12	46101800	05Z6.8-X
•Resistor		
mR14	46229400	220Ω 1/2W N.I.R.
mR15	46227000	2.2Ω 1/2W N.I.R.
mR16	00188900	33Ω 2W N.I.R.
mR17, 18	46228400	33Ω 1/2W N.I.R.
•Capacitor		
mC11	08680400	0.01μF 500V C.C.

4-13. F-3727 POWER Switch Circuit Board

Component Side

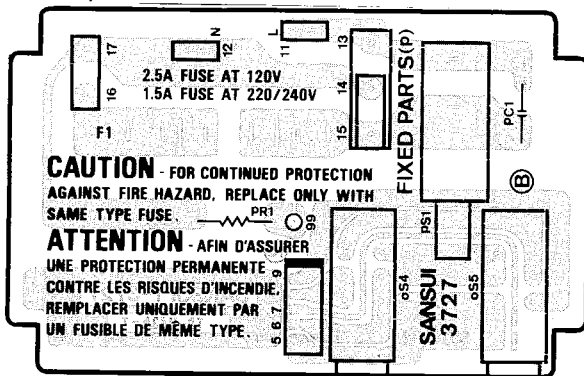

Parts List

Parts No.	Stock No.	Description
oS4	46414000	Push SW., Signal ON/OFF
oS5	46360800	Push SW., Signal ON/OFF
pC1	46425800	0.01μF 400V C.C.
pF1	07189000	4A 250V (120V)
	07188600	2A 250V (220/240V)
pS1	46364300	Push SW., POWER

4-14. F-3731 Speaker Selector Circuit Board

Parts List

Parts No.	Stock No.	Description
kR11	46229400	220Ω 1/2W N.I.R.
oS3	46361100	Push SW., SPEAKER
oJ1	46265700	Jack

4-15. F-3732 Speaker Terminal Circuit Board

Parts List

Parts No.	Stock No.	Description
kR101, kR102	46227800	10Ω 1/2W N.I.R.
	46364100	8P Push Terminal, speaker

4-17. F-3863 Tuning Switch Circuit Board

Parts List

Parts No.	Stock No.	Description
sS1, 2	46396700	Push SW., TUNING

4-18. F-3865 Tape-2 Switch Circuit Board

Parts List

Parts No.	Stock No.	Description
oS11	46361000	Push SW.

5. OTHER PARTS

5-1. Display Stage

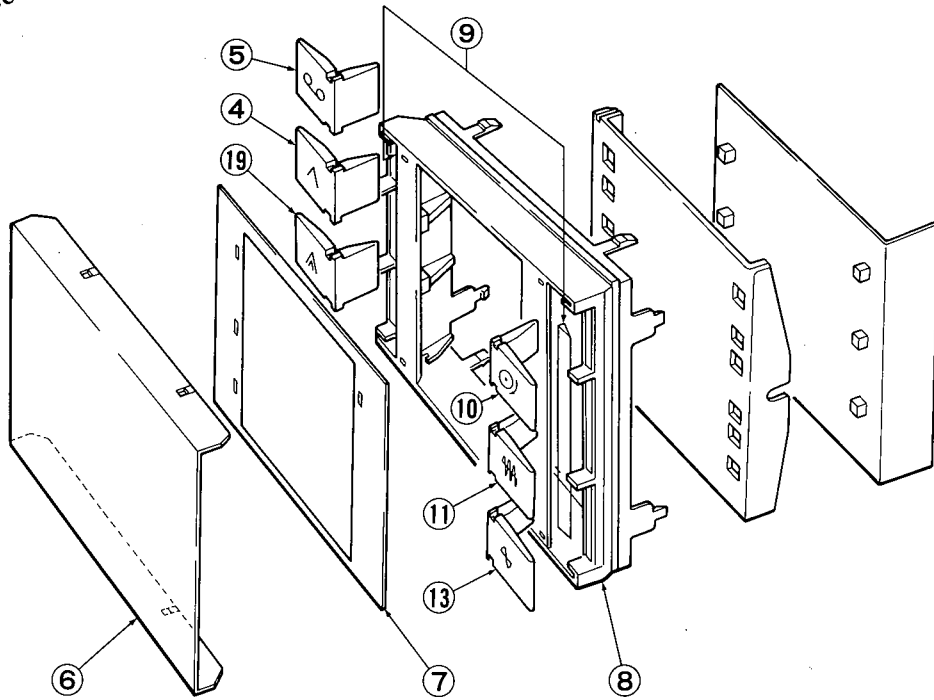

Parts List <Display Stage>

Parts No.	Stock No.	Description
4	07924000	Knob, AUTO
	46395900	Push SW., AUTO
5	07925000	Knob, TAPE-1
	46395900	Push SW., TAPE-1
6	47012000	Display Cover (R-707)
	47012100	Display Cover (R-707L)
7	07953900	Display Panel
8	47011700	Display Holder
9	47025800	Cushion Rubber

Parts No.	Stock No.	Description
10	07924400	Knob, PHONO
	46395900	Push SW., PHONO
11	07924300	Knob, FM
	46395900	Push SW., FM
13	07924200	Knob, AM
	46395900	Push SW., AM
19	07924100	Knob, MANUAL
	46395900	Push SW., MANUAL

5-2. Front View

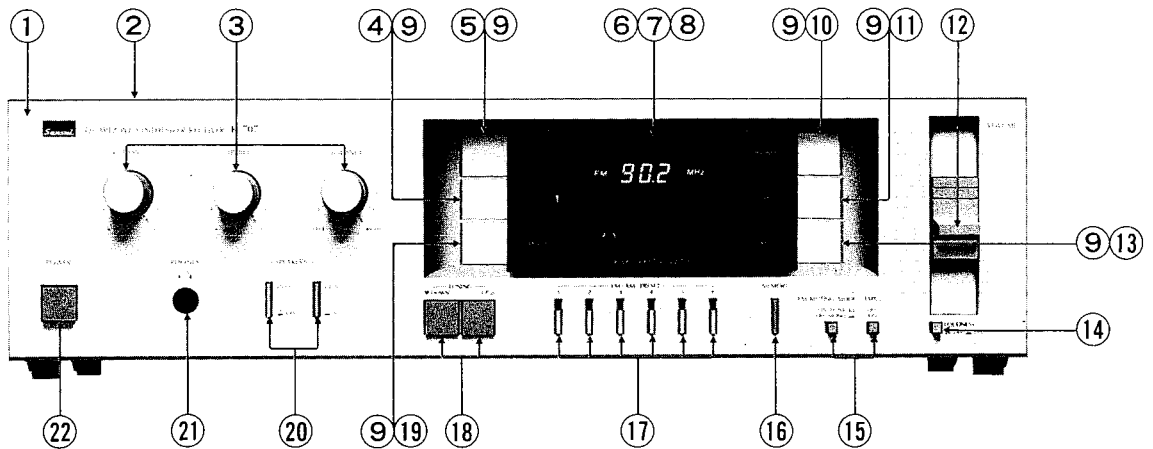

5-3. Top View

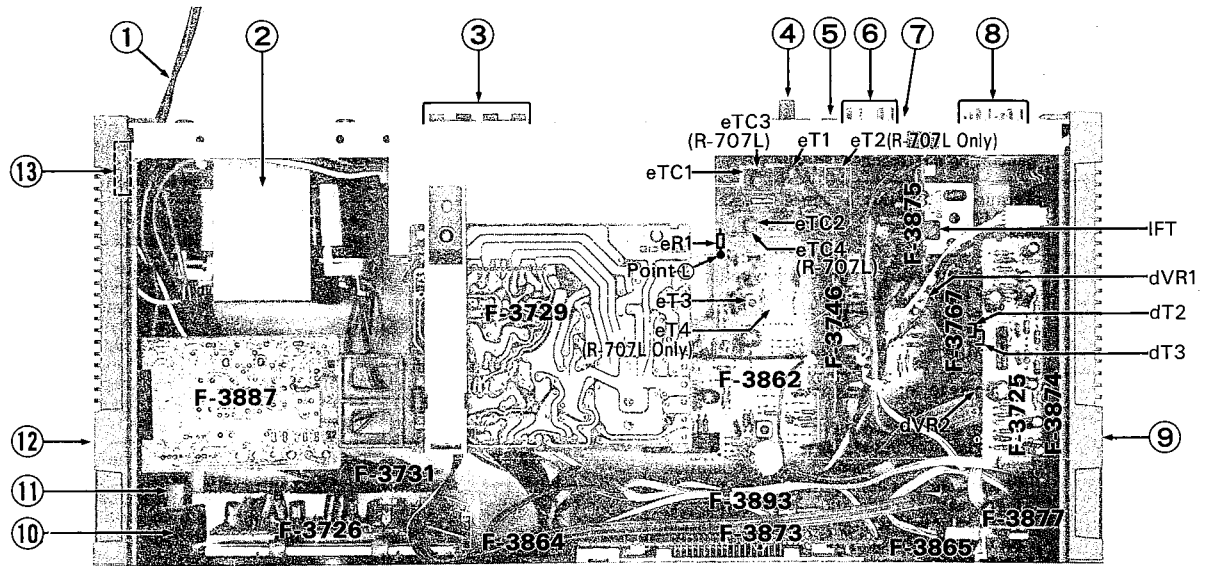

Parts List <Front View>

Parts No.	Stock No.	Description
1	07978200	Front Panel Ass'y (R-707)
	07978300	Front Panel Ass'y (R-707L)
2	07952400	Bonnet
3	07932400	Knob, BASS, TREBLE, BALANCE
	46363100	50k Ω x 2 250k Ω VR, BASS, TREBLE, BALANCE
4	07924000	Knob, AUTO
	46395900	Push SW., AUTO
5	07925000	Knob, TAPE-1
	46395900	Push SW., TAPE-1
6	47012000	Display Cover (R-707)
	47012100	Display Cover (R-707L)
7	07953900	Display Panel
8	47011700	Display Holder
9	47025800	Cushion Rubber
10	07924400	Knob, PHONO
	46395900	Push SW., PHONO
11	07924300	Knob, FM
	46395900	Push SW., FM
12	07932600	Knob, VOLUME
	46395300	150k Ω Slide VR, VOLUME
13	07924200	Knob, AM
	46395900	Push SW., AM
14	07917200	Knob, LOUDNESS
	46360900	Push SW., LOUDNESS
15	07931500	Knob, FM MUTING/MODE, TAPE-2
	46361000	Push SW., FM MUTING/MODE, TAPE-2
16	47021100	Knob, MEMORY
	46395900	Push SW., MEMORY
17	07931100	Knob, FM/AM PRESET
	46395900	Push SW., FM/AM PRESET
18	07911300	Knob, TUNING
	46396700	Push SW., TUNING
19	07924100	Knob, MANUAL
	46395900	Push SW., MANUAL
20	47005500	Knob, SPEAKERS
	46361100	Push SW., SPEAKERS
21	46265700	Jack, PHONES
22	07971210	Knob, POWER
	46364300	Push SW., POWER

Parts List <Top View>

Parts No.	Stock No.	Description
1	38004700	Power Supply Cord (R-707)
	38004500	Power Supply Cord (R-707L)
2	15009201	Power Transformer (R-707)
	15009205	Power Transformer (R-707L)
3	46364100	8P Push Terminal, speaker
4	22301500	Ground Terminal
5	46364200	Antenna Terminal
6	46363700	2P Terminal, PHONO
7	46148200	Jack, COMPU SELECTOR
8	46371500	4P Terminal, TAPE-1, TAPE-2
9	07952700	Side Panel-R
10	07934100	Joint Shaft (C),
11	07934000	Joint Shaft (B),
12	07952600	Side Panel-L
13	07917700	AC Cord Cover
	46399400	AC OUTLETS (R-707)
	46161000	AC OUTLETS (R-707L)
	07204700	Slide SW., VOLTAGE SELECTOR (R-707L)

6. TERMINAL FUNCTION & INTERIOR BLOCK DIAGRAM OF IC

• Interior block diagram of LC7815H and LC4066BH are shown on page 2.

• Terminal Function of LSI-TC9147P

Pin No.	Pin name	Description of Function and Operation
2, 3	X _T X _T	Terminals to connect a quartz oscillator for generating a reference frequency.
4 5 6	FM MW LW	Terminals to input a signal for switching FM/MW/LW band.
7 8	MANUAL AUTO	Terminal to input a signal for switching the manual operation to automatic search operation or vice versa in the UP/DOWN tuning mode. "H": Automatic, "L": Manual
9 10	UP DOWN	Terminals to input a signal from the tuning key. * In manual operation: When the key is kept depressed for 0.3 sec or more in one-step/one-push step feeding, the operation changes to fast forwarding; when the key is released, the operation stops at the next stop. In this case, even if there is a station on the way, the station is neglected. * In automatic search operation: When the key is depressed once, the automatic search operation starts and stops automatically after having selected the desired station.
11	STO	Terminal to input a signal for storing data in the preset memory unit. Input/output terminal in which a LED driver is provided. * When depressing the STO key, the STO lamp comes on. Next, when any desired memory No. key is depressed, the data on receiving frequency is written into the memory unit and the STO lamp goes off. * When the STO key is depressed and the memory No. key is not depressed, the frequency data is released automatically.
12 17	M1 M6	Terminals to input a signal for designating memory address. Input/output terminals in which a LED driver is provided. * Terminals M ₁ to M ₆ designate the addresses of FM memory unit in FM receiving and the addresses of AM memory unit in AM receiving. * When depressing the STO key and any desired station key of M ₁ to M ₆ , the data is written into the memory unit. * When depressing any desired station key of M ₁ to M ₆ , the data is read out.
22	OSC 2	Terminal to connect a condenser and resistor for the oscillator for determining the speed of AM automatic search operation.
23	OSC 1	Terminal to connect a condenser and resistor for the oscillator for determining the speed of FM automatic search operation.
24 25 26 27	0/5 CK2 CK1 DATA	Terminals to output the data for displaying the received frequency digitally and a timing signal. The data fed to the driver TD6301P for displaying a static frequency and the timing signal are outputted once only when the frequency is updated in such case as when the power supply is tuned on, the UP/DOWN key is depressed, the automatic scanning operation is made, the data are read out of the memory unit, or FM/AM is switched. In the ordinary receiving state, this terminal is fixed to a "L" level. * 0/5: For displaying 50 kHz during FM receiving in Europe. * Data: Binary coded frequency data and receiving band. * CK-1, CK-2: Initialize and transfer clock signals.

Pin No.	Pin name	Description of Function and Operation																		
28	MUTE	Terminal to output the muting signal. The terminal is kept in "L" level in ordinary state, and in "H" level in muting.																		
29 30	E2 E1	Terminals to input a signal for selecting destinations of Japan, USA, and Europe. <table border="1" style="margin-left: 20px;"> <thead> <tr> <th>E₁</th> <th>E₂</th> <th>Mode</th> </tr> </thead> <tbody> <tr> <td>0</td> <td>0</td> <td>Japan</td> </tr> <tr> <td>1</td> <td>0</td> <td>Europe</td> </tr> <tr> <td>0</td> <td>1</td> <td>USA</td> </tr> <tr> <td>1</td> <td>1</td> <td>USA (MW 9kHz)</td> </tr> <tr> <td></td> <td></td> <td>USA (MW 10kHz)</td> </tr> </tbody> </table> * Inputs of terminals E ₁ and E ₂ are read and latched in INH = L state and in FM/AM switching.	E ₁	E ₂	Mode	0	0	Japan	1	0	Europe	0	1	USA	1	1	USA (MW 9kHz)			USA (MW 10kHz)
E ₁	E ₂	Mode																		
0	0	Japan																		
1	0	Europe																		
0	1	USA																		
1	1	USA (MW 9kHz)																		
		USA (MW 10kHz)																		
31	STOP 3	When a 1F450 kHz signal is applied to this terminal during automatic search operation, the scanning operation stops.																		
32	STOP 2	Terminal to input a signal for performing the automatic search stop. When a "H" level signal is applied to STOP 1 and this terminal during automatic search operation, the scanning operation stops.																		
33	STOP 1	Terminal to input a signal for slowing the speed of scanning operation. When a "H" level signal is applied to this terminal during automatic search operation, the speed of scanning operation halves.																		
34 35	DO-2 DO-1	Terminals to output a signal from a phase comparator. These terminals can be used for FM and AM, separately, since the same signal is outputted from the terminals D ₀ -1 and D ₀ -2 at the same time.																		
36	TEST	Terminal to input a signal of test mode. Test mode in "H" level.																		
37	FM _{IN}	Terminal to input a signal from the FM programmable counter. An amplifier is provided in the input.																		
38	PSC	Terminal to output a signal for controlling the Prescaler IC of TD6104P.																		
39	AM _{IN}	Terminal to input a signal from the AM programmable counter. An amplifier is provided in the input.																		
40	INH	Terminal to input a signal of inhibit. Ordinary operation in "H" level; inhibit operation in "L" level.																		
41	INT	Terminal to input an initialize signal. This terminal changes to H level in the ordinary operation and to L level in the initialize operation.																		
42 1	V _{DD} GND	Power supply terminals. 5V ± 0.5V.																		

● TC9147P (PLL & Control IC)

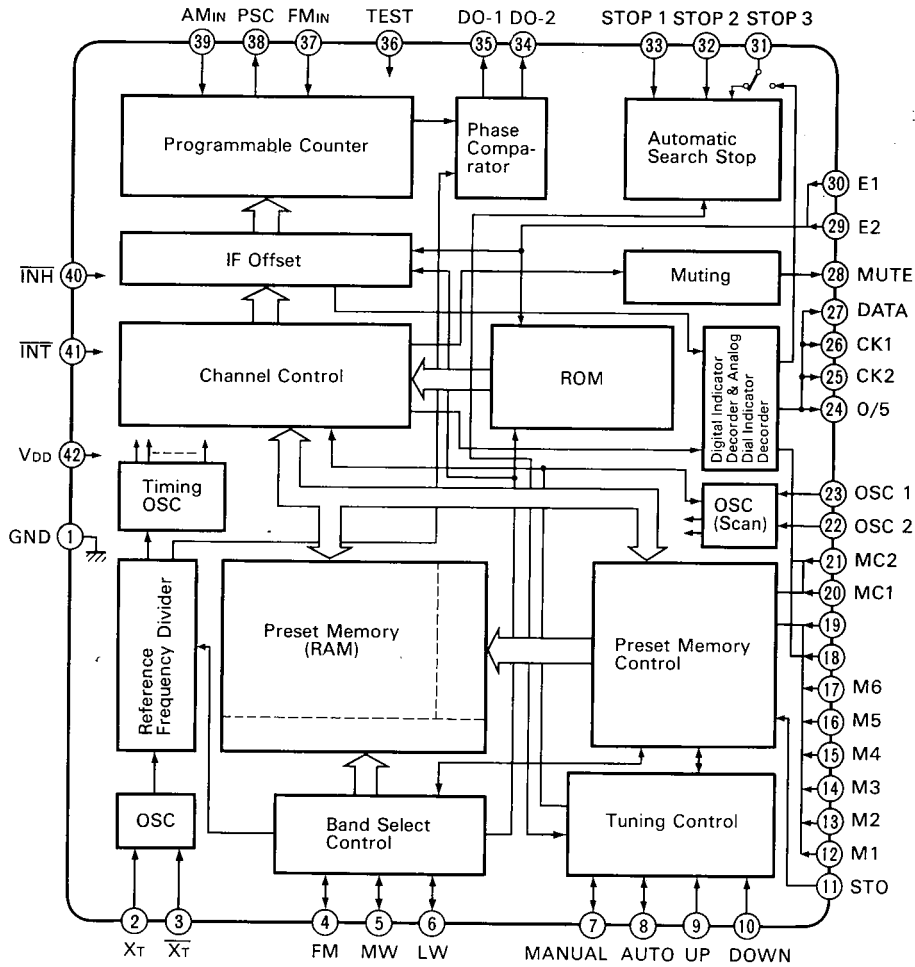

● TD6104P (Prescaler IC)

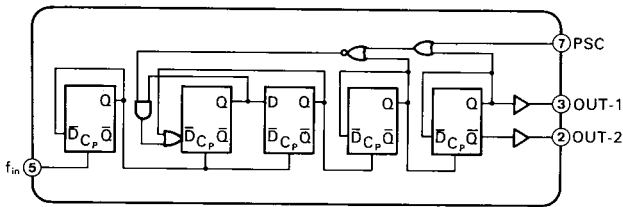

● TC4011P (Quad NAND IC)

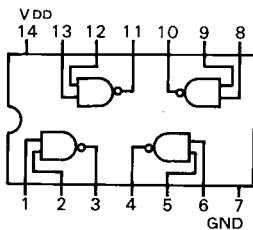

● Terminal Function of LSI-TD6104P

Pin No.	Pin Name	Description of Function and Operation
2	OUT-2	Terminal to output an inversed signal of terminal OUT-1. An additional resistor is necessary because of an open-emitter circuit. This terminal is kept open in the ordinary state.
3	OUT-1	Terminal to output a signal obtained by dividing the input signal from the division frequency output terminal fin into 1/30 or 1/32. * Output level: 0.5(V) minimum.
5	fin	Terminal to input a signal from the FM local oscillator. * Frequency range: 60 ~ 140 MHz * Input level: 75 ~ 300 mVrms
6	C	Terminal to connect a pass-condenser for the bias circuit. A condenser of 2200 pF is connected between this terminal and ground.
7	PSC	Terminal to switch the frequency division ratio. $V_{psc} \geq 2(V) : 1/32$ $V_{psc} \leq 1(V) : 1/30$
1	Vcc	Power supply terminal $V_{cc} = 5V$ $I_{cc} = TYP 5mA, MAX 10mA$
4	GND	Ground

• STK2250 (AF Power Amp. IC)

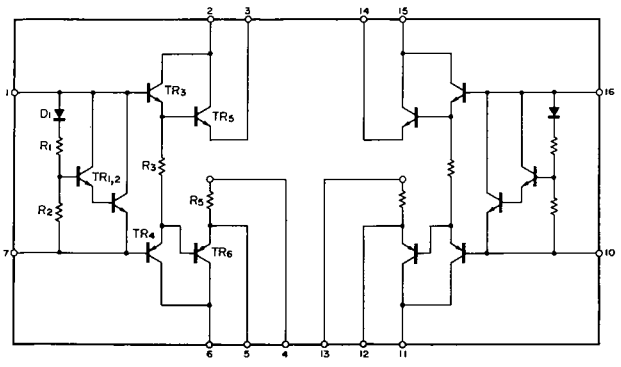

• M5218L (Audio PRE Amp. IC)

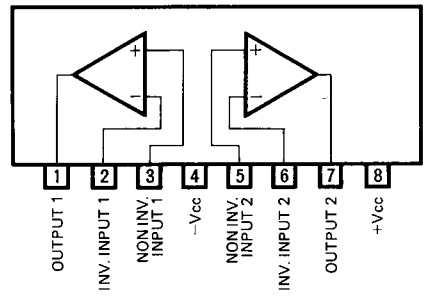

• STK3041 (Driver Amplifier IC)

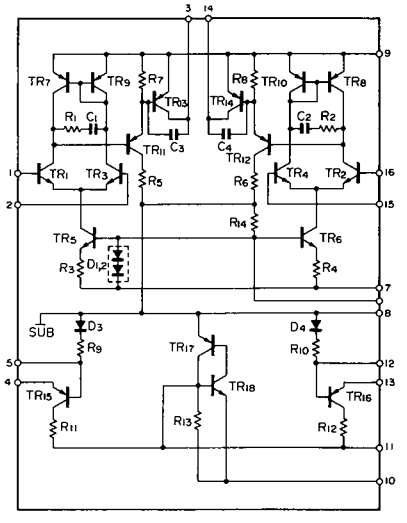

• LA1231N (IF & Quadrature Detector IC)

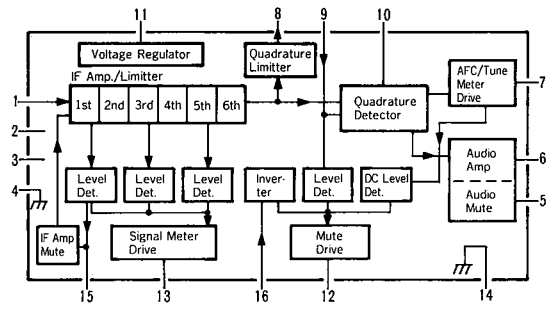

• HA1197 (AM Tuner IC)

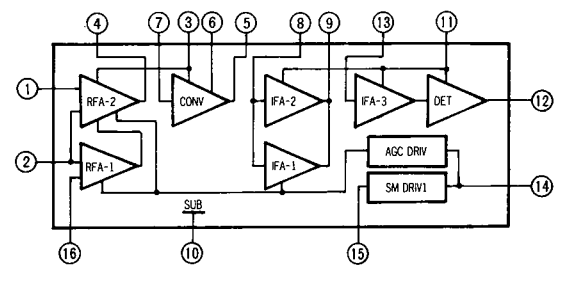

• TD6301P (7 Segment Decoder IC)

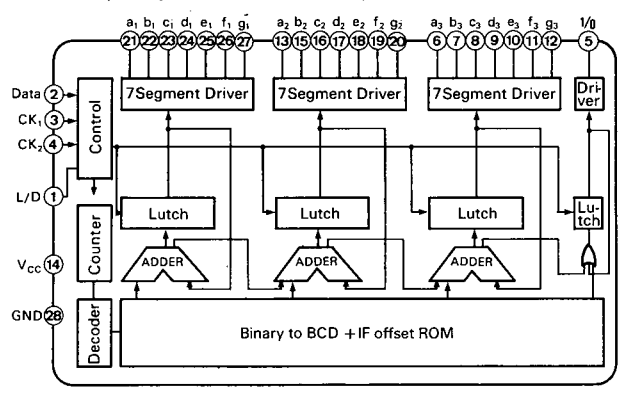

• HA1156 (MPX IC)

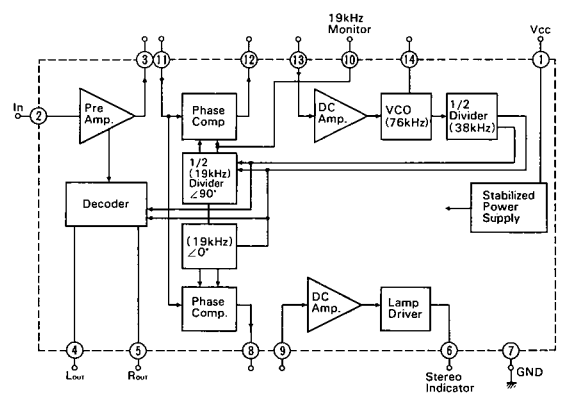

7. SCHEMATIC DIAGRAM 7-1. Tuner Section <R-707>

•Design and specifications subject to change without notice for improvement.
•La présentation et les spécifications sont susceptibles d'être modifiées sans préavis par suites d'améliorations éventuelles.
•Änderungen, die dem technischen Fortschritt dienen, bleiben vorbehalten.

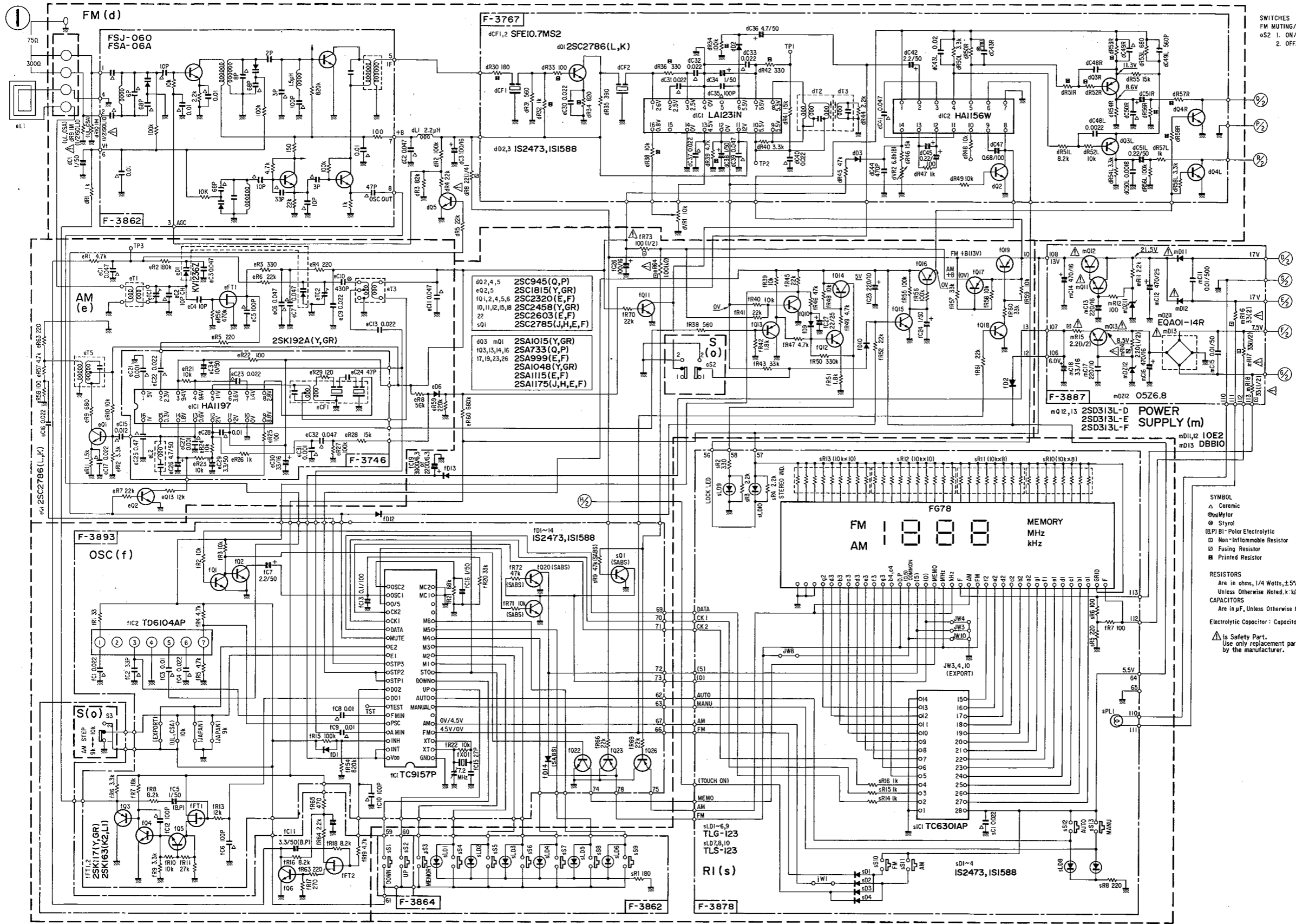

SWITCHES
FM MUTING/MODE
S2 1. ON/AUTO
2. OFF/MONO

SYMBOL
 ▲ Ceramic
 ⊕ Mylar
 ⊙ Styrol
 (P) Bi-Polar Electrolytic
 □ Non-Inflammable Resistor
 ⊞ Fusing Resistor
 ■ Printed Resistor

RESISTORS
 Are in ohms, 1/4 Watts, ±5% Tolerance
 Unless Otherwise Noted. k: kΩ, M: MΩ

CAPACITORS
 Are in μF, Unless Otherwise Noted. P: pF

Electrolytic Capacitor: Capacitance(μF)/Volt (V)

⚠ is Safety Part.
 Use only replacement parts recommended
 by the manufacturer.

1

2

3

4

5

*Design and specifications subject to change without notice for improvement.
 *La présentation et les spécifications sont susceptibles d'être modifiées sans préavis par suites d'améliorations éventuelles.
 *Änderungen, die dem technischen Fortschritt dienen, bleiben vorbehalten.

7-2. Tuner Section <R-707L>

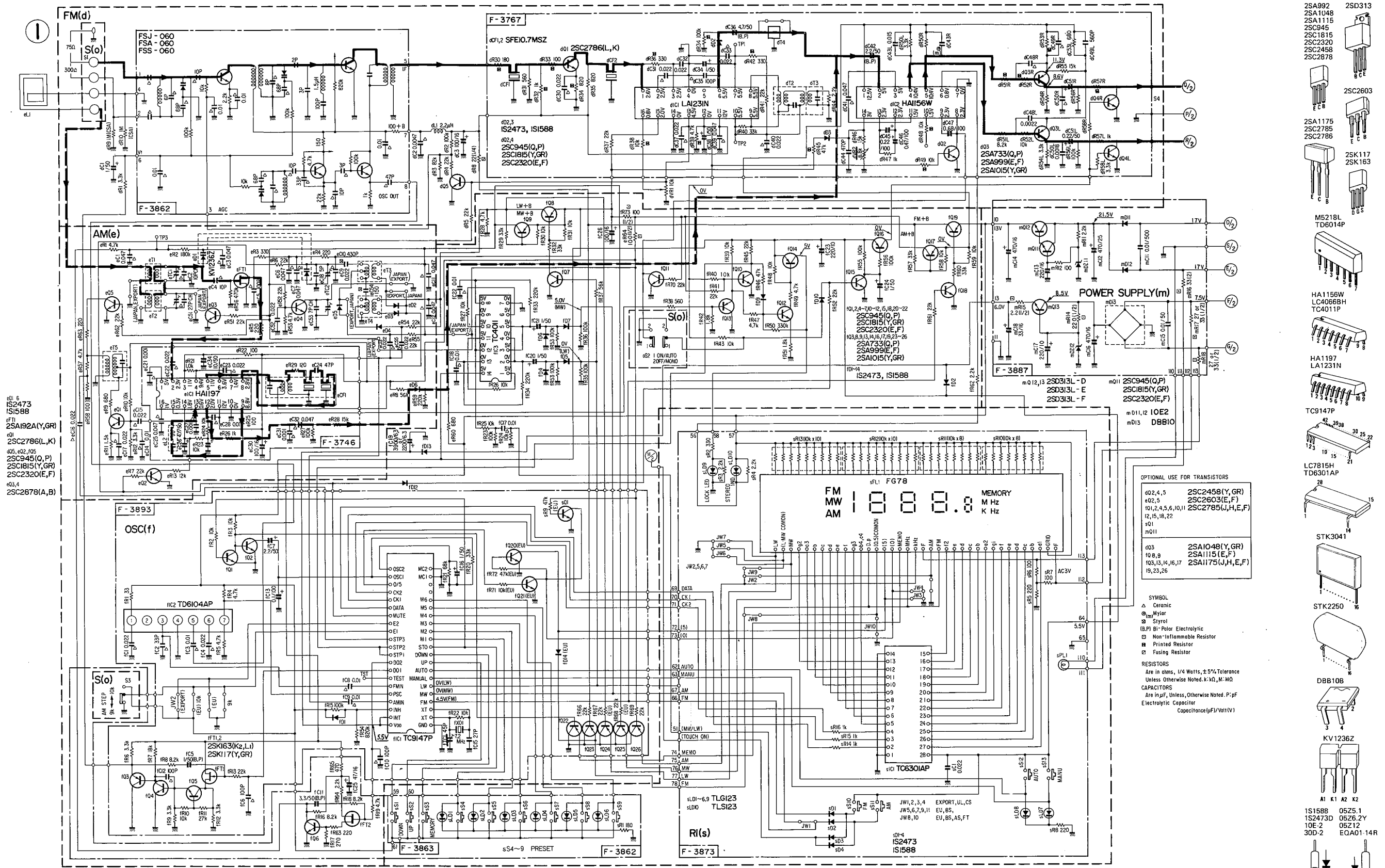

- IC1 25A733
- IC2 25A1048
- IC3 25A1115
- IC4 25C945
- IC5 25C1815
- IC6 25C2320
- IC7 25C2458
- IC8 25C2878

OPTIONAL USE FOR TRANSISTORS

IC2, 4, 5	2SC2458 (Y, GR)
IC2, 5	2SC2603 (E, F)
IC1, 2, 4, 5, 6, 10, 11	2SC2785 (J, H, E, F)
IC2, 15, 18, 22	
S01	
M011	
IC3	2SA1048 (Y, GR)
IC8, 9	2SA1115 (E, F)
IC3, 13, 14, 16, 17	2SA1175 (J, H, E, F)
IC9, 23, 26	

SYMBOL
 △ Ceramic
 □ Mylar
 ○ Styrol
 (B.P) Bi-Polar Electrolytic
 □ Non-Inflammable Resistor
 ■ Printed Resistor
 □ Fusing Resistor

RESISTORS
 Are in ohms, 1/4 Watts, ±5% Tolerance
 Unless Otherwise Noted. K:kΩ, M:MΩ

CAPACITORS
 Are in μF, Unless, Otherwise Noted. P:pF
 Electrolytic Capacitor Capacitance μF/Volt(V)

- 2SA992
- 2SA1048
- 2SA1115
- 2SC945
- 2SC1815
- 2SC2320
- 2SC2458
- 2SC2878
- 2SD313
- 2SC2603
- 2SA1175
- 2SC2785
- 2SC2786
- 2SK117
- 2SK163

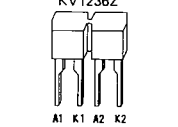
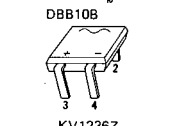
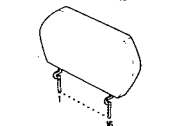
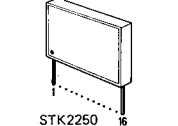
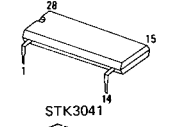
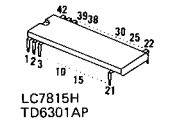
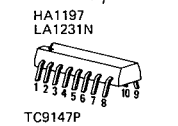
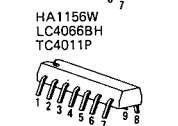
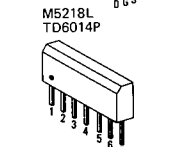

- AI K1 A2 K2
- IS1588 05Z5.1
- IS2473D 05Z6.2Y
- IOE-2 05Z12
- 30D-2 EOA01-14R

— FM Signal Line
 - - - MW/LW Signal Line

1
 2
 3
 4
 5

7-3. Audio Section <R-707/707L>

*Design and specifications subject to change without notice for improvement.
 *La présentation et les spécifications sont susceptibles d'être modifiées sans préavis par suites d'améliorations éventuelles.
 *Änderungen, die dem technischen Fortschritt dienen, bleiben vorbehalten.

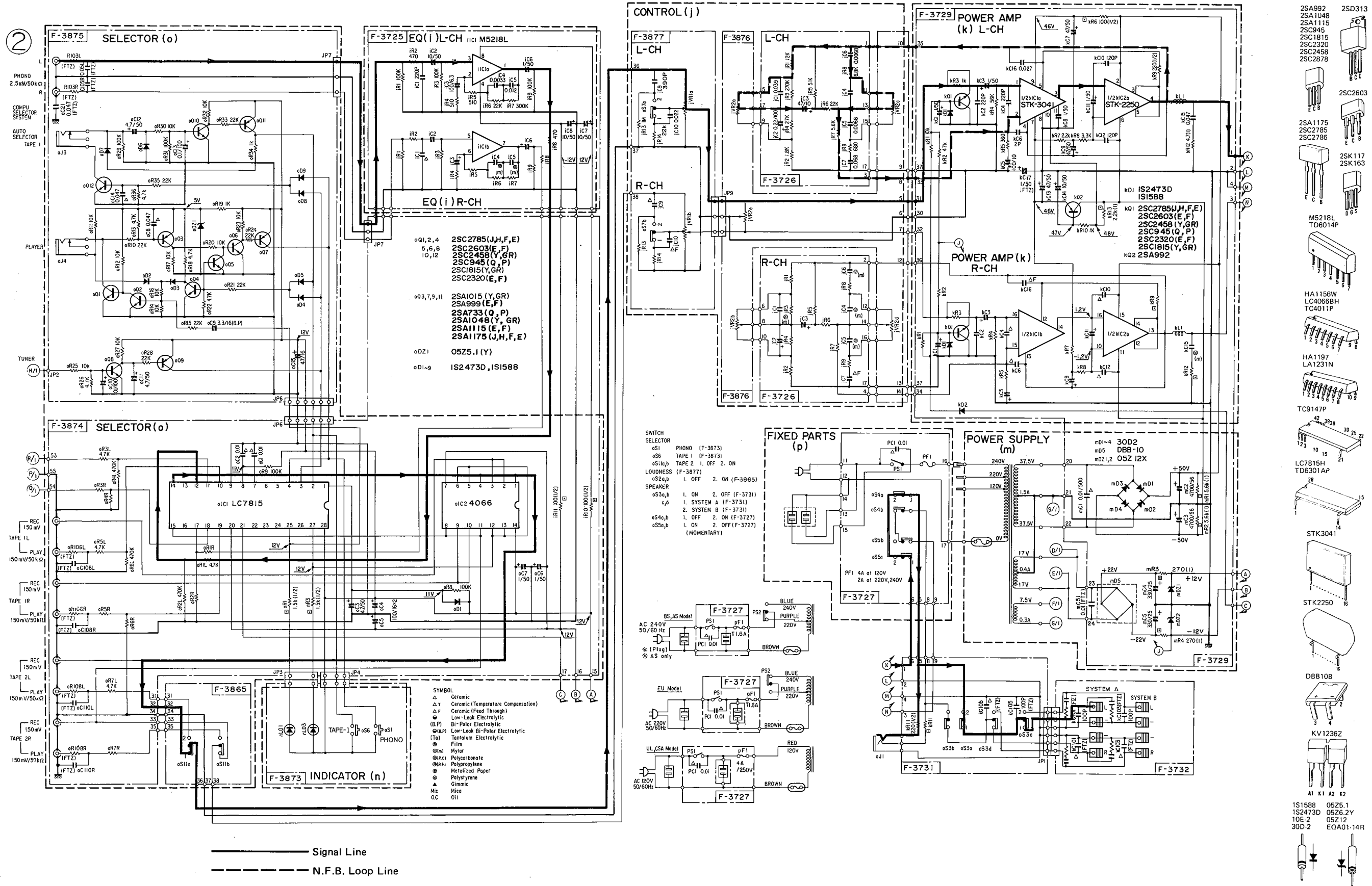

1
2
3
4
5

8. MAIN PARTS REPLACEMENT

A. Side Panel L (R) (See Fig. 8-1)

- 1) Remove bonnet and bottom plate.
- 2) Undo (H) hooks from the F-3874 circuit board.
- 3) Remove the screw (Sx) fixing side panel L (R) from rear panel side.
- 4) Shift the position of the side panel L (R) 2 cm in the arrow direction (1) and then pull it the arrow direction (2) to remove the side panel L (R).

Fig. 8-1

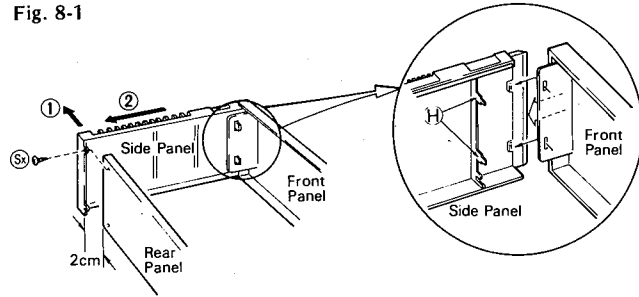

B. Display Stage

- 1) Perform "Section A. Side Panel R." first.
- 2) Remove the F-3873 circuit board.
- 3) Pull out the display stage.

9. NOTES

9-1. Notice when the user moves from 9 kHz to 10 kHz step area, or vice versa, in AM broadcasting frequency.

AM programs are being broadcast under channel plans which, depending on the broadcasting area in the world, are characterized by different channels (frequency intervals) between broadcasting stations. In North, South, and Central America, this channel is 10 kHz whereas in the rest of these areas, it is 9 kHz.

This unit is a synthesizer tuner which varies the reception frequency at each 9 kHz or 10 kHz channel (frequency interval) during auto search reception. If the client uses the unit in an area with a different channel plan, he may not be able to receive AM stations. The unit he has purchased has been originally adjusted to the channel in his area. It is therefore necessary to change over the channel setting if he moves to an area with a different channel plan.

It is impossible to receive AM broadcasting in Automatic Tuning operation. In this case, use the AM 9 kHz/10 kHz selection switch (oS3) installed on the circuit board F-3862, in accordance with Table 9-1.

If no switch oS3 is installed, change the position where the Jumper Wire is connected.

C. Front Panel Ass'y

- 1) Perform "Section B. Display Stage." first.
- 2) Remove the F-3877 circuit board with variable resistor.
- 3) Remove the F-3731 circuit board with phones jack and speaker switches.
- 4) Pluck out knobs (BASS, TREBLE, BALANCE)

Fig. 8-2

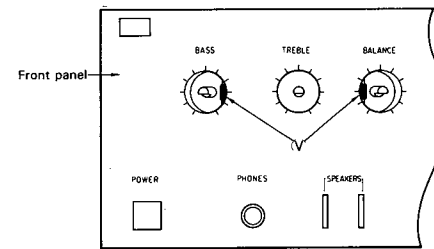

- 5) Undo (V) hooks from front panel (See Fig. 8-2) to remove the F-3876 circuit board.
- 6) Remove the F-3864 circuit board with tuning switches.
- 7) Remove the F-3877 circuit board holder.

D. Attachment of Front Panel Ass'y

- 1) Perform "Section C. Front Panel Ass'y inversely." first.

Note: Sure to insert knobs (PRESET, MEMORY, MUTING/MODE, TAPE-2) in holes of front panel before installing the side panel R.

10. PACKING LIST

Parts No.	Stock No.	Description
1	91263810	Vinyl Bag
2	07949000	Styrofoam Packing
3	07981100	Carton Case <R-707>
	07981300	Carton Case <R-707L>

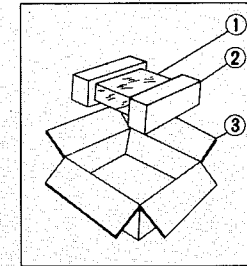

11. ACCESSORY LIST

Stock No.	Description
46356900	Operating Instruction <R-707>
46357000	Operating Instruction <R-707L>
46051700	FM Antenna
07563000	Antenna Holder
46145700	AM Loop Antenna

9-2. Notice when the user moves from 100 kHz to 50 kHz step area, or vice versa, in FM broadcasting frequency.

In this case, change the position where the Parts is connected on the circuit board F-3893 in accordance with Table 9-2.

(In most of countries, frequency-step between two FM stations is every 100 kHz, but in some areas of Europe, it is 50 kHz asides.)

Table 9-1.

Parts	10 kHz frequency step	9 kHz frequency step
Switch, oS3	Set 10 kHz	Set 9 kHz

Table 9-2.

Frequency step		Jumper Wire <F-3893>			
AM	FM	JW1	JW2	JW3	JW4
9k	100k	Remove	Connect	Remove	Remove
10k	100k	Connect	Connect	Remove	Remove
9k	50k	Connect	Remove	Connect	Remove
*9k	50k	Remove	Remove	Connect	Connect

* South African Bureau of Standard

SANSUI ELECTRIC CO., LTD.:

SANSUI ELECTRONICS CORPORATION:

SANSUI ELECTRONICS (U.K.) LTD.:
SANSUI ELECTRONICS G.M.B.H.:

14-1, Izumi 2-chome, Suginami-ku, Tokyo 168 Japan
PHONE: (03) 324-8891/TELEX: 232-2076 (International Division)
1250 Valley Brook Ave. Lyndhurst, N.J. 07071 U.S.A.
333 West Alondra Blvd. Gardena, California 90247 U.S.A.
3036 Koapaka St. Honolulu, Hawaii 96819 U.S.A.

Unit 10A, Lyon Industrial Estate, Rockware Avenue, Greenford, Middx UB6, OAA, England
Paul Ehrlich Strasse 8, 6074 Rödermark 2, West Germany

(SM1-69)

Printed in Japan (O20030M) <Stock No. 36471100>