

SERVICE MANUAL

SPECIFICATION

MODEL:RZ-5100/5110/5200AV

AMPLIFIER

1. When SURROUND is "OFF"

Sensitivity and Impedance

PHONO:2.5mV/47kΩ

CD,TAPE,AV:180mV/47kΩ

Frequency Response

PHONO(RIAA STANDARD CURVE)
:50Hz ~ 15KHz(±1dB)

CD,TAPE,AV:30Hz ~ 75KHz

Signal to Noise Ratio

PHONO (IHF-A) :65dB

CD,TAPE,AV (IHF-A) :85dB

RZ-5100AV(ASIA)/RZ-5200AV(FTC POWER):

70W,30Hz ~ 20KHz,8ohm,0.5% THD

RZ-5110AV/RZ-5100AV(Europe)(DIN POWER):

80W,1KHz,8ohm,0.5% THD

2. When SURROUND is "ON" (4 Ch surround mode)

Power Output

RZ-5100AV(ASIA)/RZ-5200AV

Front : 50 + 50W (1KHz,0.1% THD,8ohm)

Rear : 15 + 15W (1KHz,0.5% THD,8ohm)

RZ-5110AV/RZ-5100AV(Europe)(DIN POWER):

Front : 50 + 50W (1KHz,0.1% THD,8ohm)

Rear : 15 + 15W (1KHz,0.5% THD,8ohm)

3. When Dolby Pro Logic is "ON"

Power output

RZ-5100AV(ASIA)/RZ-5200AV

Front : 50 + 50W (1KHz,0.1% THD,8ohm)

Center : 50W (1KHz,0.1% THD,8ohm)

Rear : 15 + 15W (1KHz,0.5% THD,8ohm)

RZ-5110AV,RZ-5100AV(Europe)(DIN POWER):

Front : 50 + 50W (1KHz,0.1% THD,8ohm)

Center : 50W (1KHz,0.1% THD,8ohm)

Rear : 15 + 15W (1KHz,0.5% THD,8ohm)

TUNER

1. FM SECTION

Frequency Range : 87.50MHz to 108.00MHz

Europe:(50KHz step)

ASIA,America:(100KHz step)

Sensitivity(S/N 30dB) : 3.0μV

Total Harmonic Distortion

MONO:0.2%, STEREO:0.5%

Signal to Noise Ratio

MONO:65dB, STEREO:60dB

Frequency Response : 20Hz ~ 15KHz

Image Rejection : 60dB

Stereo Separation(1KHz) : 40dB

2. AM SECTION

Frequency Range :

Europe,ASIA : 522KHz to 1620KHz(9KHz step)

America : 530KHz to 1720KHz(10KHz step)

Sensitivity(S/N 30dB) : 60dB

Total Harmonic Distortion : 2%

Signal to Noise Ratio : 40dB

Image Rejection : 35dB

GENERAL

Power consumption

RZ-5110AV/RZ-5100AV(Europe) : 170W

RZ-5100AV(ASIA)/RZ-5200AV(STD) : 160W

RZ-5200AV(UL) : 180W

Power supply

RZ-5110AV/RZ-5100AV(Europe) : 230V,50Hz

RZ-5100AV(ASIA)/RZ-5200AV(STD):115V,230V/50Hz,60Hz

RZ-5200AV(UL) : 120V,60Hz

Dimension(W×H×D) : 430×147×398 mm

Weight : 9.35Kg

Standard accessories

Remote control unit.....1

Operator's manual.....1

CONTENTS

SAFETY INSTRUCTIONS.....	3
MEASUREMENTS AND ADJUSTMENTS.....	4
ADJUSTMENT POINT.....	7
IC PIN FUNCTION.....	9
ACTIVE DEVICES VOLTAGE.....	16
WIRING DIAGRAM.....	19
BLOCK DIAGRAM.....	21
SCHEMATIC DIAGRAM.....	25
PRINTED CIRCUIT BOARDS.....	37
EXPLODED VIEW.....	45
PARTS LIST.....	51

SAFETY INSTRUCTIONS

PRECAUTIONS DURING SERVICING

1. Parts identified by the \triangle (*) symbol parts are critical for safety. Replace only with parts number specified.
2. In addition to safety, other parts and assemblies are specified for conformance with such regulations as those applying to spurious radiation. These must also be replaced only with specified replacements. Examples: RF converters, tuner units, antenna selectswitches, RF cables, noise blocking capacitors, noise blocking filters, etc.
3. Use specified internal wiring. Note especially:
 - 1) Wires covered with PVC tubing
 - 2) Double insulated wires
 - 3) High voltage leads
4. Use specified insulating materials for hazardous live parts. Note especially:
 - 1) Insulation Tape
 - 2) PVC tubing
 - 3) Spacers (insulating barriers)
 - 4) Insulation sheets for transistors
 - 5) Plastic screws for fixing micro switches
5. When replacing AC primary side components (transformers, power cords, noise blocking capacitors, etc.), wrap ends of wires securely about the terminals before soldering.

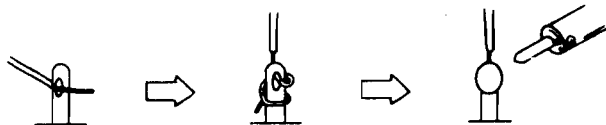

6. Make sure that wires do not contact heat producing parts (heat sinks, oxide metal film resistors, fusible resistors, etc.).
7. Check that replaced wires do not contact sharp edged or pointed parts.
8. Also check areas surrounding repaired locations.
9. Make sure that foreign objects (screws, solder droplets, etc.) do not remain inside the set.

MAKE YOUR CONTRIBUTION TO PROTECT THE ENVIRONMENT

Used batteries with the ISO symbol for recycling as well as small accumulators (rechargeable batteries), mini-batteries (cells) and starter batteries should not be thrown into the garbage can.



Please leave them at an appropriate depot. All other household batteries can be thrown out with the household waste.

SAFETY CHECK AFTER SERVICING

After servicing, make measurements of leakage-current or resistance in order to determine that exposed parts are acceptably insulated from the supply circuit.

The leakage-current measurement should be done between accessible metal parts (such as chassis, ground terminal, microphone jacks, signal input/output connectors, etc.) and the earth ground through a resistor of 1500 ohms paralleled with a 0.15 μ F capacitor, under the unit's normal working conditions.

The leakage-current should be less than 0.5mA rms AC. The resistance measurement should be done between accessible exposed metal parts and power cord plug prongs with the power switch (if included) "ON". The resistance should be more than 2.2M Ohms.

PRECAUTIONS IN REPAIRING

When repairing or adjusting the unit, please note the following points.

1. Do not put excessive pressure on the mechanical part (operation part), including the pick-up block, as extremely high mechanical precision is required in these parts.
2. When the base is removed for repair adjustment, make sure that there are no metal objects in the narrow gap between the P. C. board or the mecha parts and the base.
3. The Micro-Computer and the CD signal processing ICs can be damaged by static electricity or leakage from a soldering iron during repairing. While soldering, please take the precautions against leakage as in the illustration.

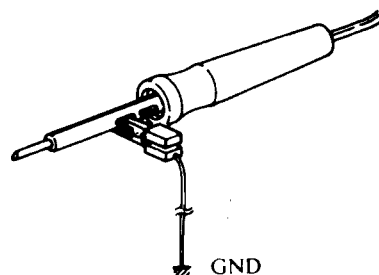

4. Do not loosen any screws in the pick-up block. When handling the pick-up block, please refer to the points to NOTE when replacing the pick-up block.
5. Keep safety for hazardous invisible Laser Radiation, DO NOT watch the Laser Beam (Objective lens) directly.
6. Models for some countries, laser warning labels are affixed on the unit and inside of the unit, as shown below. Read it carefully for your safety, when repairing or adjusting the unit.

MEASUREMENTS AND ADJUSTMENTS

ALIGNMENT INSTRUCTIONS

EQUIPMENT NEEDED:

- AM Signal Generator
- FM Signal Generator
- Oscilloscope
- VTVM (AC,DC)
- Test loop antenna (AM Adjustment)
- Dummy antenna (FM Adjustment)
- Stereo signal modulator (RDS IN:EUROPE Only)

IMPORTANT

1. Check power-source voltage.
2. Set the function switch to band aligned.
3. Keep the signal input as low as possible to adjust accurately.
4. Modulation and modulation frequency.

Band \ Item	Modulation	Modulation frequency
AM	30%	400Hz
FM	100% (75KHz Dec.)	400Hz

1. TUNING FREQUENCY RANGE ADJUSTMENTS

(FM,AM) DC VOLTMETER CONNECT TO TEST POINT TP54 AND GND

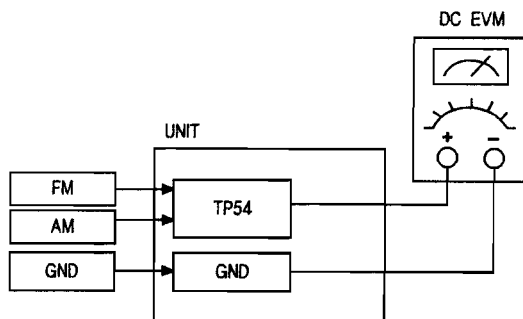

(EUROPE/ASIA)

NO	Band	Frequency	Adjust for	Adjustment
1	FM	87.50MHz	1.5V	L7
2	AM	522KHz	1V	L502

(AMERICA)

NO	Band	Frequency	Adjust for	Adjustment
1	FM	87.50MHz	1.5V	L7
2	AM	530KHz	1V	L502

2. AM TRACKING ADJUSTMENT

Signal Generator Connects to the AM ANT. Coil through the loop antenna.

Adjust for the indication of VTVM of the wave form scope to be maximum.

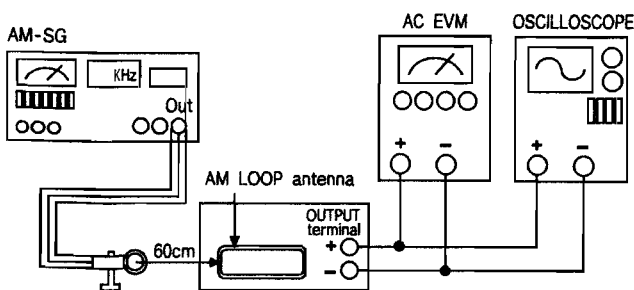

(EUROPE/ASIA)

Band	Step	Frequency	Adjust for	Adjustment
AM	1	612KHz	Maximum sensitivity	L501,L502
	2	1503KHz	Maximum sensitivity	CT51
	3	Repeat steps 1 and 2 several times		

(AMERICA)

Band	Step	Frequency	Adjust for	Adjustment
AM	1	610KHz	Maximum sensitivity	L501,L502
	2	1500KHz	Maximum sensitivity	CT51
	3	Repeat steps 1 and 2 several times		

3. FM RF ADJUSTMENT

Signal Generator Connects to the FM ANT JACK(FM IN) through the dummy.

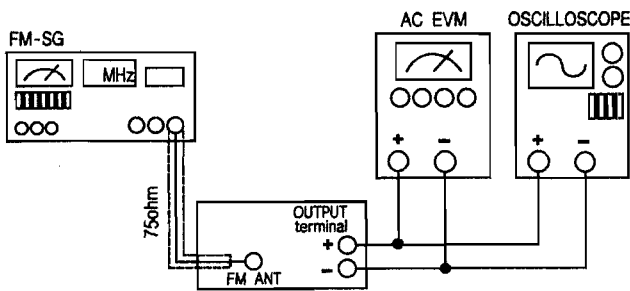

No.	Frequency	Adjust for	Adjustment
1	87.50MHz	Maximum sensitivity	L2,L5,L6
2	Repeat steps 1 and 2 several times		

4. FM MONO DISTORTION ADJUSTMENT

DC VOLTMETER CONNECT TO TP51(-),TP52(+) Through the choke coil(100uH)

Signal Generator Connects to the FM ANT JACK(FM IN) through the dummy.

Distortion Meter..... Connect to the output.

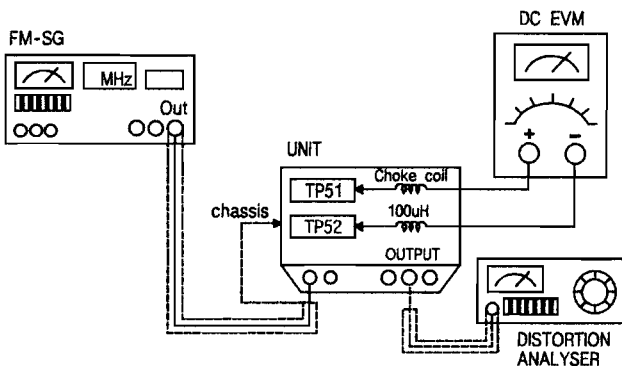

No.	Frequency	Adjust for	Adjustment
1	100.10MHz	DC Voltmeter 0V	T501
2	100.10MHz	Minimum T.H.D.	T502
3	Repeat steps 1 and 2 several times		

5. FM STEREO SEPARATION

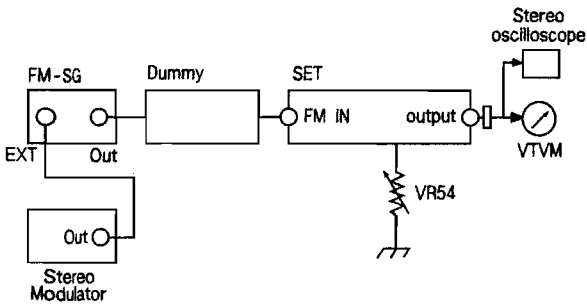

Pilot signal	Adjust for	Adjustment
ON	Different of R or L must be maximum	VR54

NOTE : In case of adjusting the stereo separation of input is L(or R) channel,R (or L) channel must be maximum.

6. FM/AM AUTO STOP LEVEL ADJUSTMENT

FM Signal Generator Connect to the FM ANT JACK(FM IN) through the dummy.

Signal Generator Connect to the AM ANT. Coil through the loop antenna.

(EUROPE/ASIA)

Band	Step	Frequency	Adjust for	Adjustment
FM	1	100.1MHz, 35dB	TUNED Display OFF	VR52
	2	100.1MHz, 35dB	TUNED Display ON	VR52
AM	1	999KHz, 80dB	TUNED Display OFF	VR51
	2	999KHz, 80dB	TUNED Display ON	VR51

(AMERICA)

Band	Step	Frequency	Adjust for	Adjustment
AM	1	990KHz, 80dB	TUNED Display OFF	VR51
	2	990KHz, 80dB	TUNED Display ON	VR51

7. FM RDS ADJUSTMENT (EUROPE Only)

FM Signal Generator(RDS IN) Connect to the FM ANT JACK(FM IN) through the dummy.

Oscilloscope..... Connect to TP53(+) GND(-)

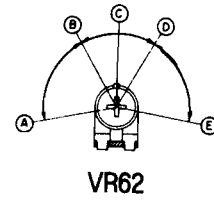
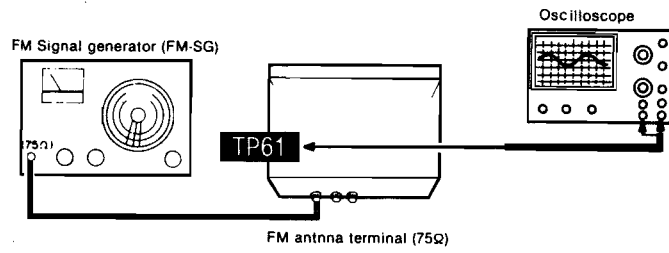

- A-B,D-E : RDS OFF position.
- B-D : RDS ON position.(indicator lighting)
- C : Adjust point of RDS circuit.
(TP53:1.0 ~ 1.2V)

ADJUSTMENT POINT

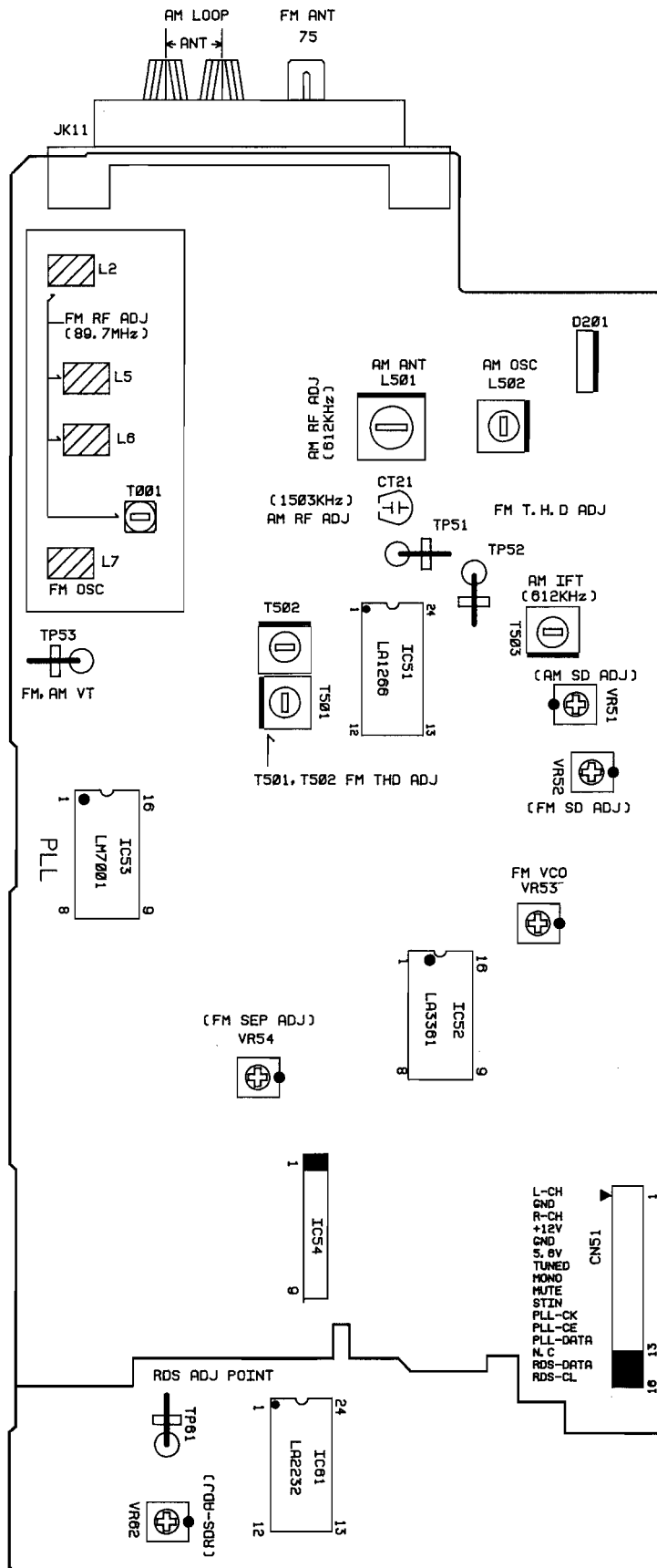

(EUROPE ONLY)

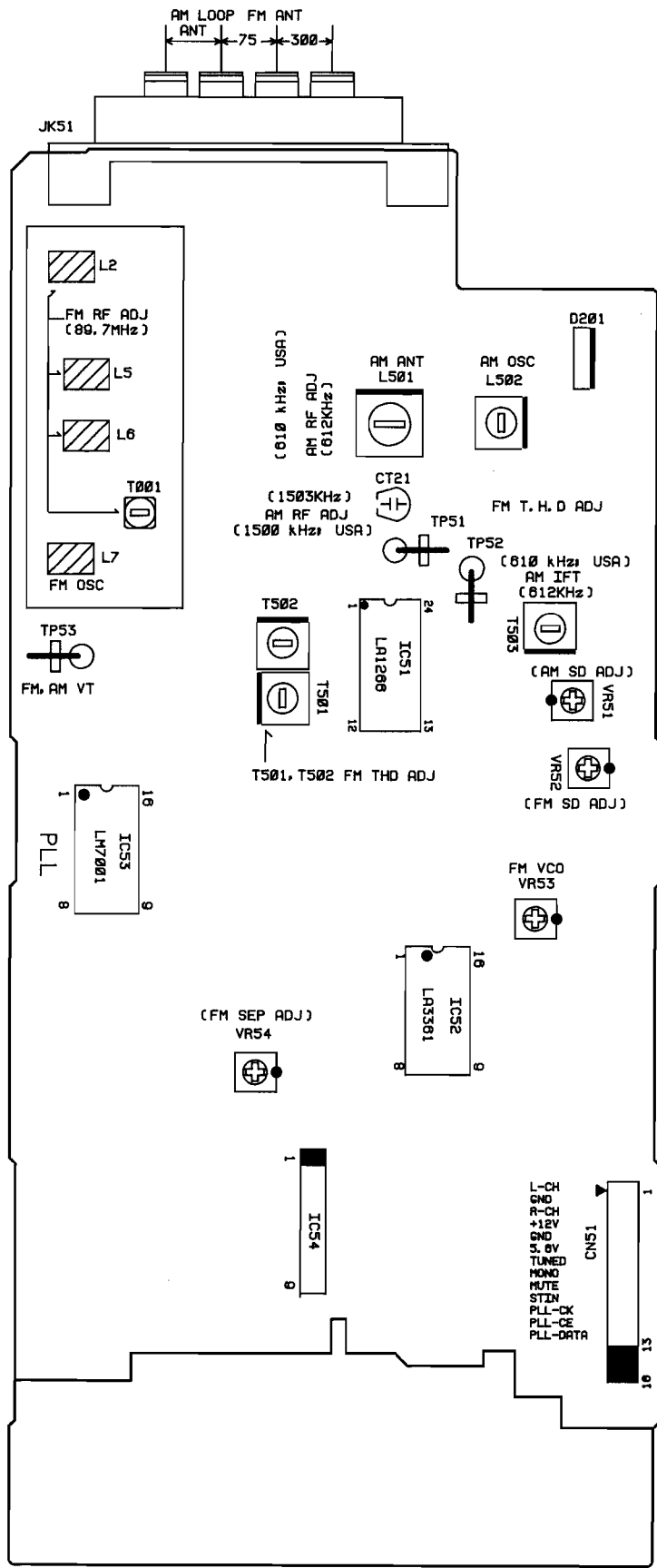

(ASIA, USA, ETC)

IC PIN FUNCTION (IC : ANAM1174M)

PIN No.	PIN NAME	I/O	DESCRIPTION
1	VDD	-	Power supply (+5V)
2 ~5	OPTION	I	Devices option port
6	TUNER MUTE	O	Tuner mute on/off control output
7	MONO	I	MONO control input
8	RDS MUTE	O	RDS mute on/off control output
9	FUNCTION MUTE	O	Function mute on/off control output
10	N.C	-	Non connection
11	RDS DATA	O	RDS data output
12	N.C	-	Non connection
13	RDS CLOCK	O	RDS clock output
14	STEREO IN	I	Stereo in control input
15	TUNED	I	Tuned control input
16	PROTECT IN	I	Input form protection circuit
17~21	KEY MATRIX	I	Key MATRIX ports
22	VSS	-	GND
23	AVSS	-	GND
24	VAREF	-	A/D convertor reference voltage
25	VDD	-	Power supply (+5V)
26	BACK UP	I	Back-up mode control input
27	TEST	-	GND
28,29	N.C	-	Non connection
30	VSS	-	GND
31	XIN	I	8MHz Crystal connecting terminal
32	XOUT	O	8MHz Crystal connecting terminal
33	RESET	I	System reset pulse input
34	REMOTE IN	I	Remote control signal input
35		-	
36		-	
37	POWER ON/OFF	O	Power on/off control output
38	SURROUND ON/OFF	O	Surround on/off control output
39	-20dB MUTE	O	-20dB mute on/off control output
40	REMOTE OUT	O	System remote control output
41	SURROUND CLOCK	O	Surround clock output
42	PLL CE	O	PLL CE output
43	STROBE	O	STROBE output
44	REQ	O	REQ output
45	CLOCK	O	CLOCK output
46	DATA	O	DATA output
47	AV2 CONTROL	O	AV2 Video function control output
48	AV1 CONTROL	O	AV1 Video function control output
49	CD CONTROL	O	CD Video function control output
50	VFLP	-	(-33V) Negative power supply for FIP blinking
51~74	SEGMENT	O	FIP SEGMENT control outputs
75~89	GRID	O	FIP grid control outputs
90	N.C	-	Non connection
91	VR UP	O	Volume UP control outputs
92	VR DOWN	O	Volume DOWN control outputs
93	VR LED	O	Volume LED ON/OFF control outputs
94	POWER LED	O	Power LED ON/OFF control outputs
95~98	N.C	-	Non connection
99,100	SEGMENT	O	FIP SEGMENT control outputs

(U-COM FUNCTION : BVIANAM1174 T)

**PIN ASSIGNMENTS
(TOP VIEW)**

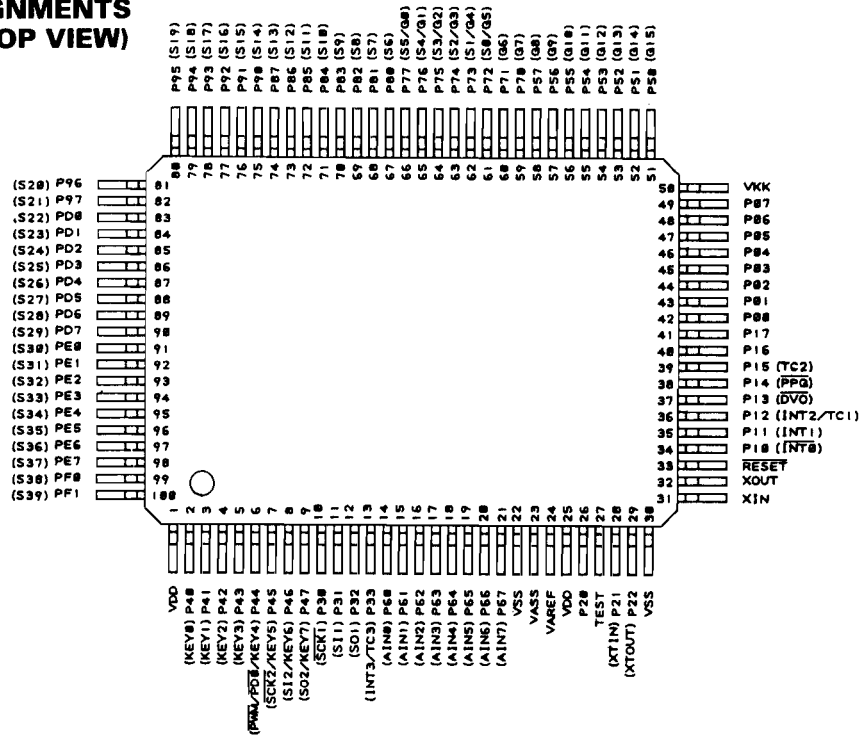

BLOCK DIAGRAM

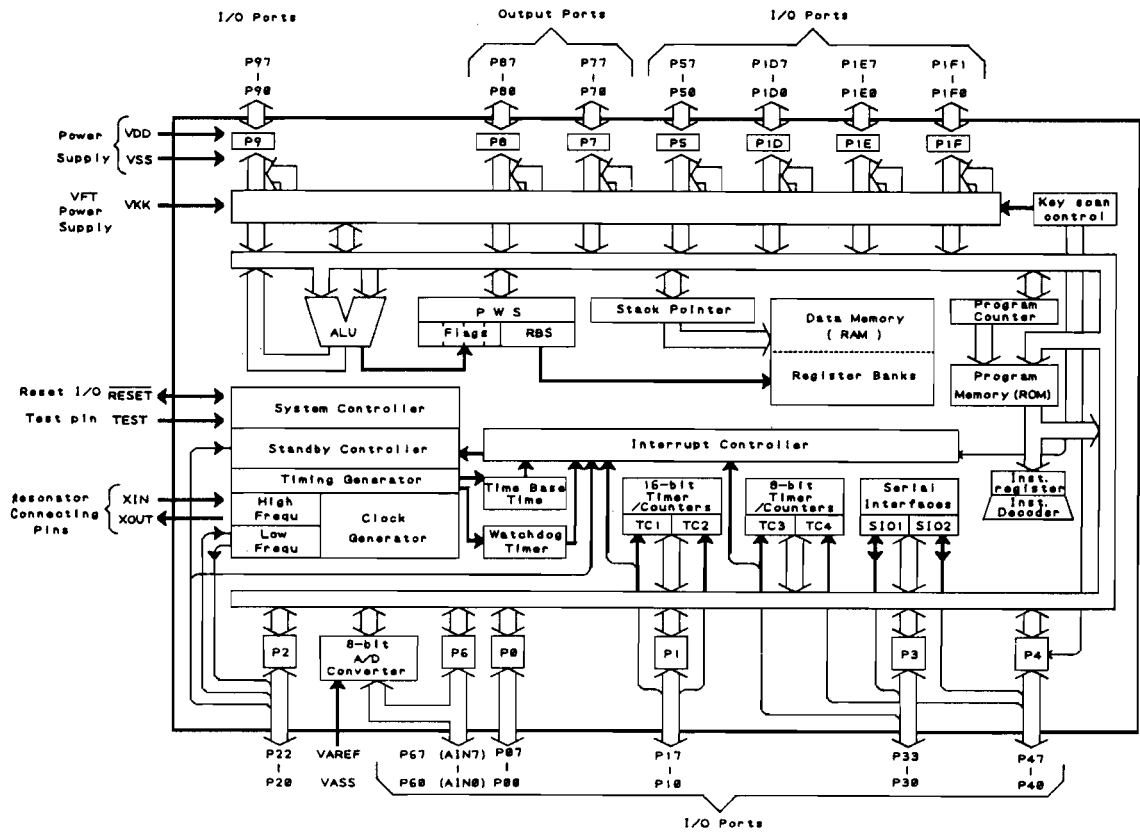

NJN7311AL

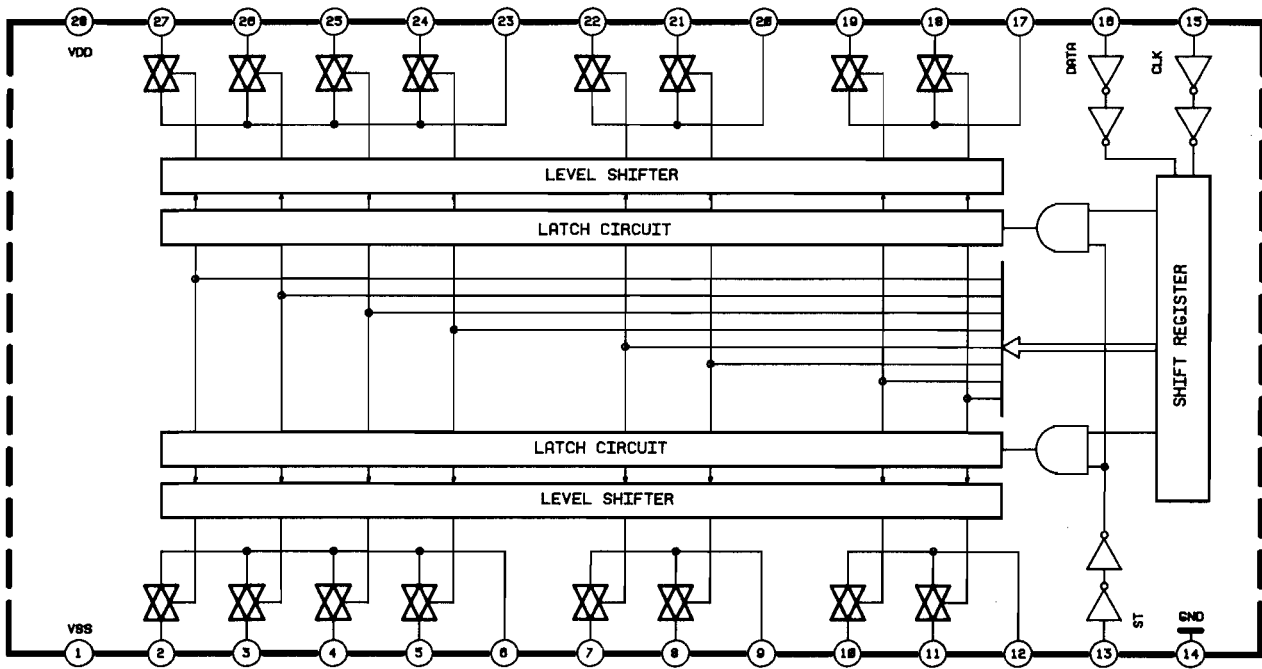

NJN7313AL

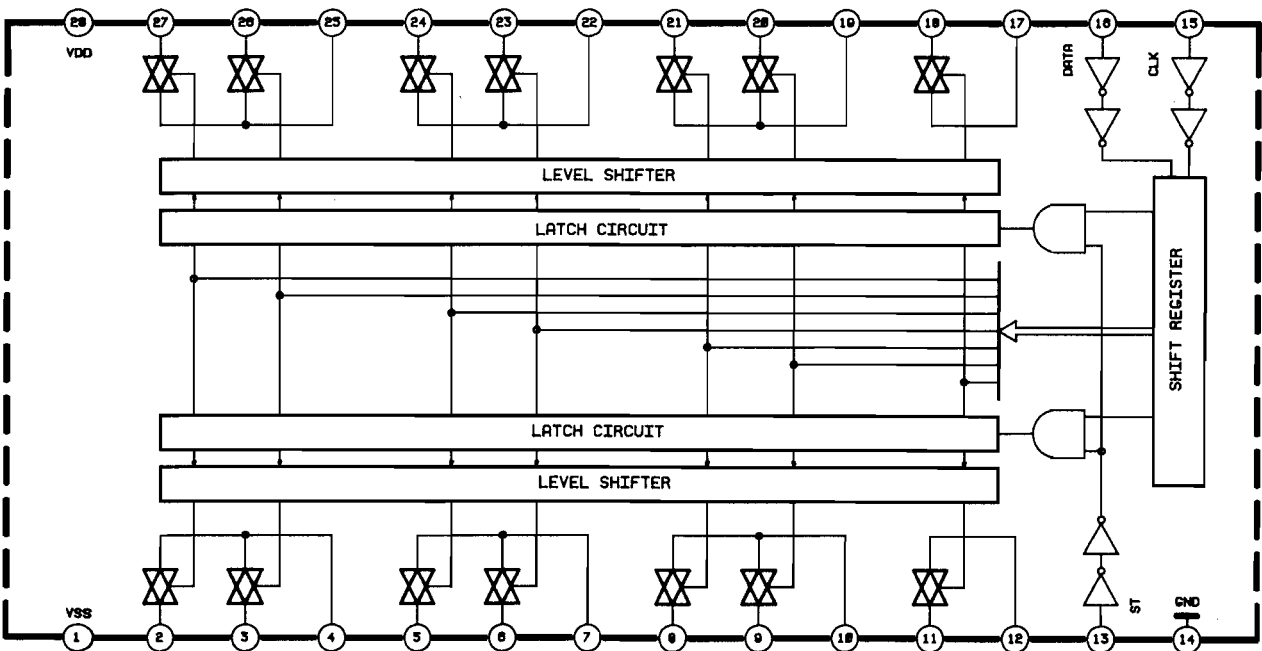

NJN4558S, KIA6259S

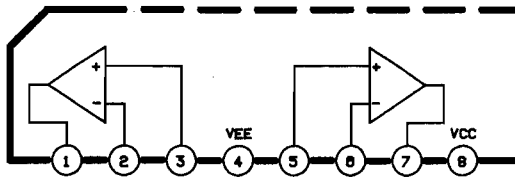

LM7001 PLL

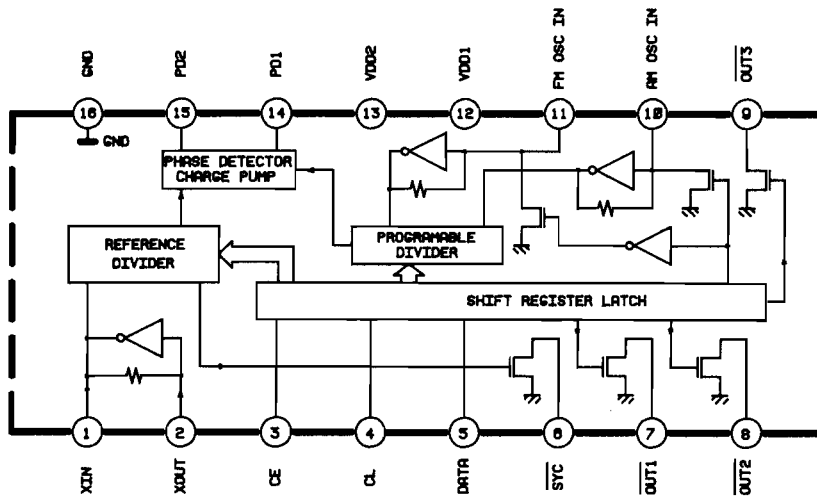

MJU9702D

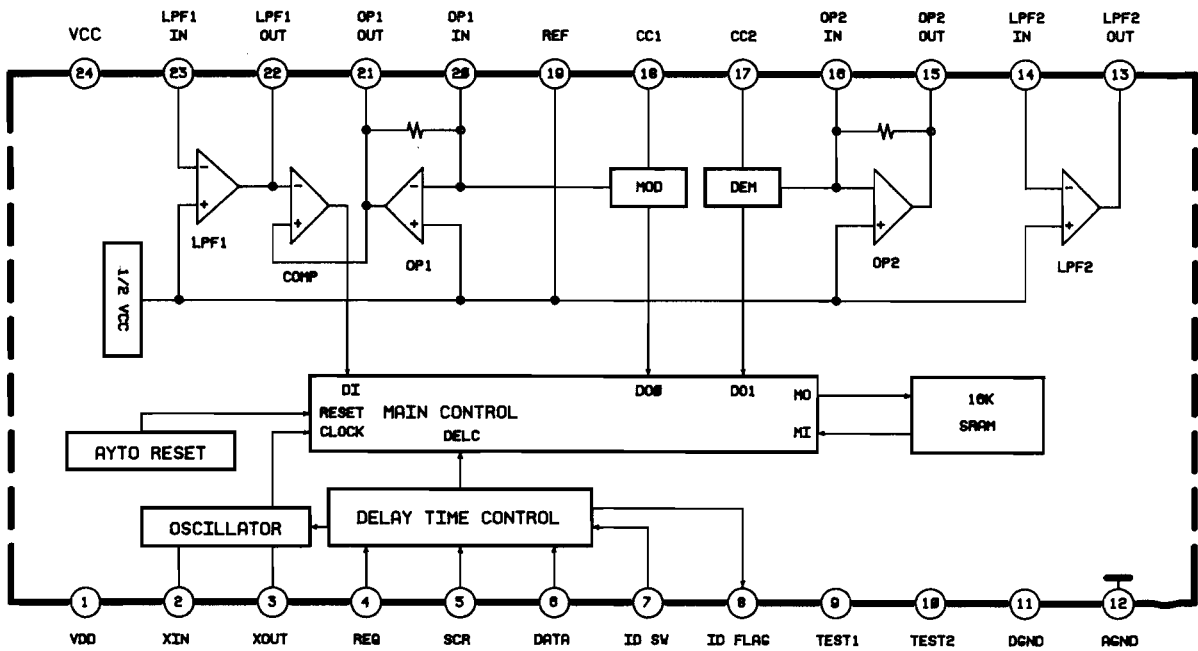

LA1266 FM IF & AM RF/IF

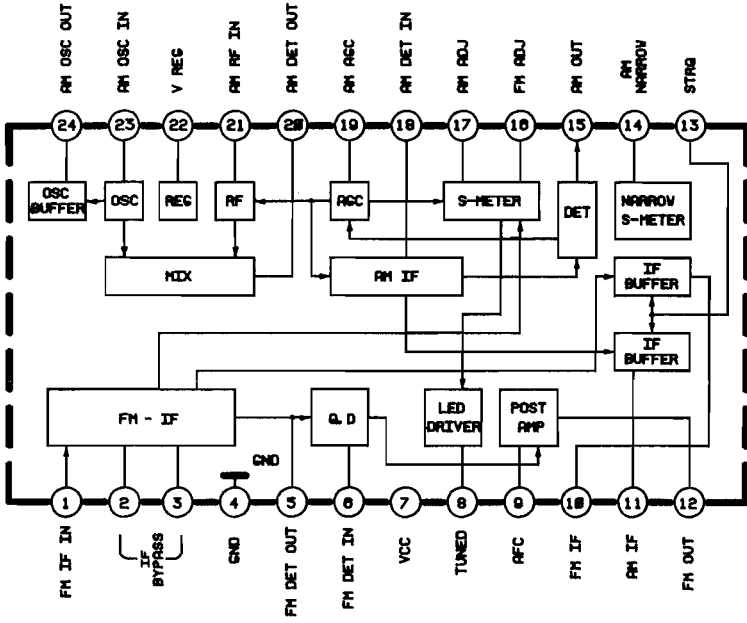

LA3361 MPX

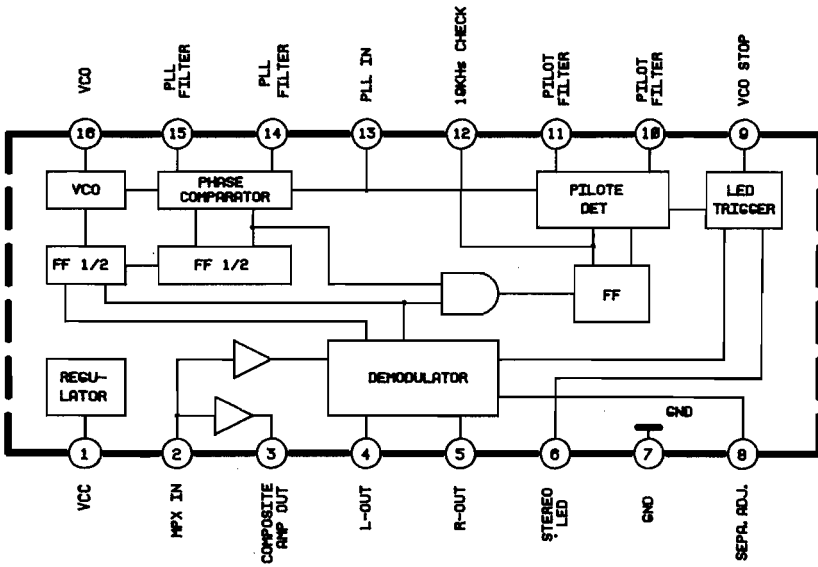

RESVA30CC
RESVL30CC

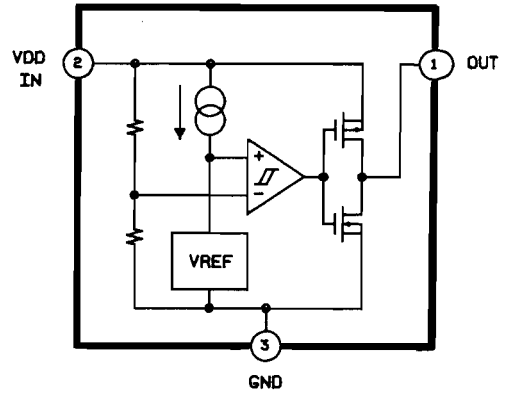

GD 4066B

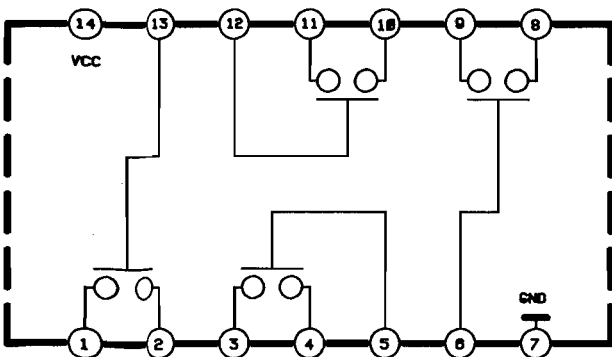

MC4558S

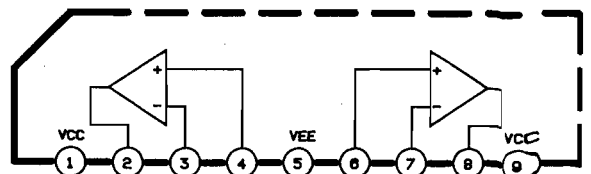



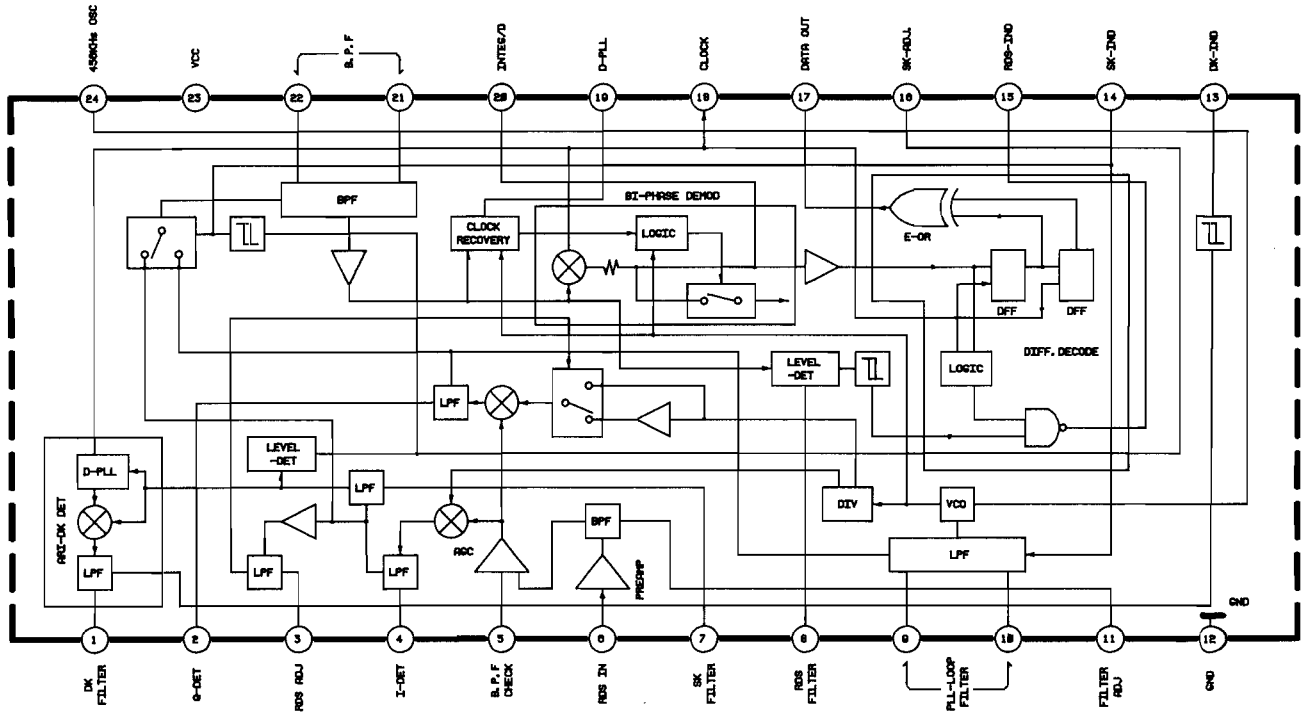

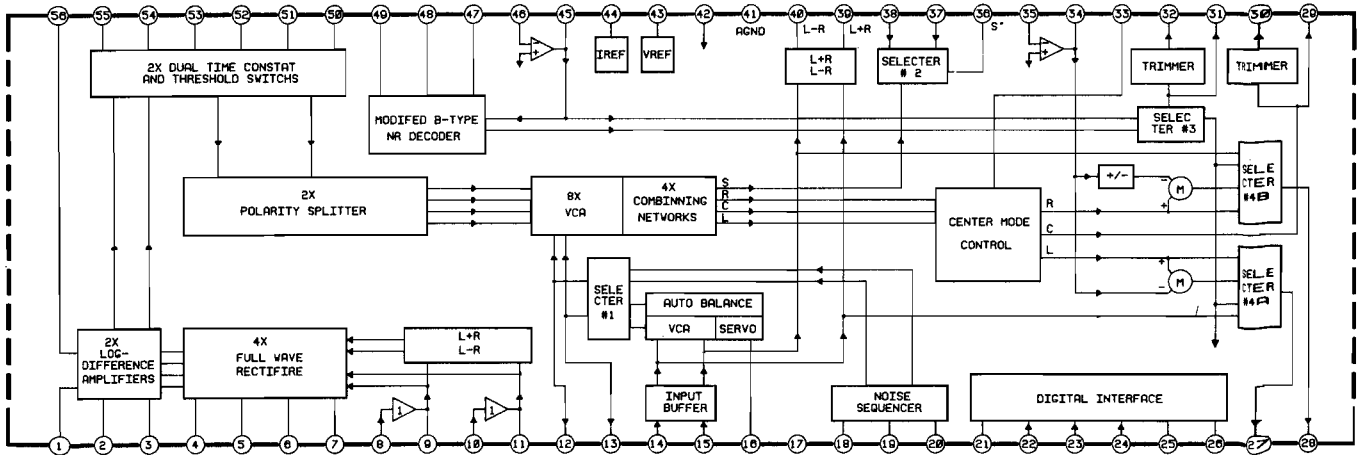

LA2232 RDS ENCODER

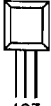

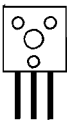
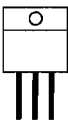
NJW1102L

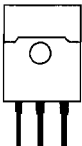
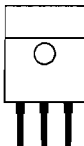

<p>T0-92S</p>  <p>1, EMITTER 2, COLLECTOR 3, BASE</p> <p>123</p> <p>DTA114YS DTC114YS 2SC1740SR KSC2785Y DTC114TS KSR2208 KSA1175Y KSD1021Y KSA811Y</p>	<p>T0-92</p>  <p>1, EMITTER 2, COLLECTOR 3, BASE</p> <p>123</p> <p>KTC2878B KSA902F KSA733CY KSC945CY KTA1271Y KTC3203Y KTC31920</p>	<p>T0-92L</p>  <p>1, EMITTER 2, COLLECTOR 3, BASE</p> <p>1 2 3</p> <p>KSA916Y KSC2316Y</p>
<p>T0-126</p>  <p>1, EMITTER 2, COLLECTOR 3, BASE</p> <p>1 2 3</p> <p>KSA1220A KSC2090A</p>	<p>T0-220</p>  <p>1, BASE 2, COLLECTOR 3, EMITTER</p> <p>1 2 3</p> <p>KSD288Y KSA614Y</p>	<p>T0-220F</p>  <p>1, BASE 2, COLLECTOR 3, EMITTER</p> <p>1 2 3</p> <p>2SD1585L</p>
<p>T0-3P</p>  <p>1, BASE 2, COLLECTOR 3, EMITTER</p> <p>1 2 3</p> <p>2SA1694 2SC4467</p>	<p>T0-3PF</p>  <p>1, BASE 2, COLLECTOR 3, EMITTER</p> <p>1 2 3</p> <p>KTD9980 KT87780</p>	<p>T0-220</p>  <p>1, INPUT 2, GND 3, OUTPUT</p> <p>1 2 3</p> <p>MC7805C MC7812C MC7912C</p>

ACTIVE DEVICES VOLTAGE

TEST CONDITION

- Function : CD (No signal)
- Surround mode : OFF (BYPASS)
- Unit : V

Ref. No.	E	C	B	Ref. No.	E	C	B
Q1,Q2	0	0	-11.7	Q713,Q714	-0.6	-54.4	-1.1
Q101,Q103	0	0	-11.7	Q715,Q716	0	57.3	0.6
Q102,Q104	0	0	-11.9	Q717,Q718	0	-57.3	-0.6
Q105,Q106	0.6	-52.6	0	Q719,Q720	0	0	-11.7
Q107,Q108	0.6	-52.6	0	Q721,Q722	0	0	-11.9
Q109,Q110	-1.1	1.2	-0.5	Q723,Q724	0	11.7	0
Q111,Q112	-53.1	-0.6	-52.6	Q725	11.8	0	11.8
Q113,Q114	-53.1	-1.1	-52.6	Q726	0	11.5	0
Q115,Q116	0.6	54.4	1.2	Q727	0	11.7	0
Q117,Q118	-0.6	-54.4	-1.1	Q728	0	11.7	0
Q119,Q120	0	57.3	0.6	Q729	0	1.1	0
Q121,Q122	0	-57.3	-0.6	Q730	12	0	12
Q123,Q124	0	11.7	0	Q801	55	57	55.6
Q125	12	0	12	Q802	57	56	55
Q126	0	12	0	Q803	0	0	0.6
Q127	0	12	0	Q804	-55	-57	-55.6
Q128	12	0	12	Q805	-57	-56	-55.7
Q130	0	11.7	0	Q806	12	-53	0
Q131,Q132	0	0	2.1	Q807	0	12	11.4
Q261,Q262,Q263	3.2	0	2.6	Q808	0	0	0.6
Q264,Q265,Q266	3.7	2	3.1	Q901	5.6	5.6	5
Q701,Q702	0.6	-52.6	0	Q902	0	4.9	0
Q703,Q704	0.6	-52.6	0	Q904	4.5	0	4.5
Q705,Q706	-53.1	-0.6	-52.6	Q905	5	0	5
Q707,Q708	-53.1	-1.1	-52.6	Q908	5	5	0
Q709,Q710	-1.1	1.2	-0.5	Q909	0	0	5
Q711,Q712	0.6	54.4	1.2	Q910	0	5.6	0

IC27		
PIN No.	DESCRIPTION	VOLTAGE
1	IN/OUT 1	0
2	OUT/IN 1	2.6
3	OUT/IN 2	2.6
4	IN/OUT 2	0
5	CONT 2	0
6	CONT 3	0
7	VSS	0
8	IN/OUT 3	0
9	OUT/IN 3	2.6
10	OUT/IN 4	2.6
11	IN/OUT 4	0
12	CONT 4	0
13	CONT 1	0
14	VCC	6

IC1,IC4,IC31,IC32,IC35		
PIN No.	DESCRIPTION	VOLTAGE
1	A OUTPUT	0
2	A - INPUT	0
3	A + INPUT	0
4	VEE	-11.7
5	B + INPUT	0
6	B - INPUT	0
7	B OUTPUT	0
8	VCC	11.7

IC42		
PIN No.	DESCRIPTION	VOLTAGE
1	RLC2	4
2	RLC1	4
3	RLC4	3.6
4	RLC7	3.6
5	RLC3	4
6	RLC8	4
7	RLC6	3.4
8	LLI	4
9	LBPF	4
10	RLI	4
11	RBPF	4
12	LT	4
13	RT	4
14	LIN	4
15	RIN	4
16	HOLDC	4
17	VCC	10
18	NGC3	4
19	NGC2	4
20	NGC1	2.5
21	VDD	4.8
22	DATA	DATA
23	SCK	SCK
24	REQ	REQ
25	IDS	0
26	VSS	0
27	LOUT	4
28	ROUT	4
29	CT	4
30	COUT	4
31	ST	4
32	SOUT	4
33	CMC	4
34	SMRO	4
35	SMRI	4
36	SD	4
37	SIMB	4
38	SIMA	4
39	L+R	4
40	L-R	4
41	GND	0
42	VREF	4
43	VREFG	4
44	IREF	1.4
45	DBIN	4
46	LPIN	4
47	DBC1	4
48	DBC2	4
49	DBC3	0
50	PSC3	4
51	PSC6	4
52	PSC2	4
53	PSC5	4
54	PSC1	4
55	PSC4	4
56	RLC5	3.4

IC2,IC3		
PIN No.	DESCRIPTION	VOLTAGE
1	VEE	-12
2	L1/L1	0
3	L2/L2	0
4	L3/LCOM1	0
5	L4/L3	0
6	LCOM1/L4	0
7	LS/LCOM2	0
8	L6/L5	0
9	LCOM2/L6	0
10	L7/LCOM3	0
11	L8/L7	0
12	LCOM3/LCOM4	0
13	STROBE	STROBE
14	GND	0
15	CK	CK
16	DATA	DATA
17	RCOM3/RCOM4	0
18	R8/R7	0
19	R7/RCOM3	0
20	RCOM2/R6	0
21	R6/R5	0
22	R5/RCOM2	0
23	RCOM1/R4	0
24	R4/R3	0
25	R3/RCOM1	0
26	R2/R2	0
27	R1/R1	0
28	VDD	11.7

IC43		
PIN No.	DESCRIPTION	VOLTAGE
1	VDD	4.7
2	XIN	1MHz
3	XOUT	1MHz
4	REQ	REQ
5	SCK	SCK
6	DATA	DATA
7	IDSW	0
8	IDFLAG	4.7
9	TEST1	0
10	TEST2	0
11	DGND	0
12	AGND	0
13	LPF2OUT	2.4
14	LPF2IN	2.4
15	OP2OUT	2.4
16	OP2IN	2.4
17	CC2	0.7
18	CC1	0.7
19	PEF	2.4
20	OP1IN	2.4
21	OP1OUT	2.4
22	LPF1OUT	2.4
23	LPF1IN	2.4
24	VCC	4.7

IC54		
PIN No.	DESCRIPTION	VOLTAGE
1	VCC	10.4
2	A OUTPUT	5.2
3	A - INPUT	5.2
4	A + INPUT	5.2
5	VEE	0
6	B + INPUT	5.2
7	B - INPUT	5.2
8	B OUTPUT	5.2
9	VCC	10.4

IC81		
PIN No.	DESCRIPTION	VOLTAGE
1	INPUT	18.3
2	GND	0
3	OUTPUT	12

IC82		
PIN No.	DESCRIPTION	VOLTAGE
1	GND	0
2	INPUT	-20
3	OUTPUT	-12

IC83		
PIN No.	DESCRIPTION	VOLTAGE
1	INPUT	11.5
2	GND	0
3	OUTPUT	5

IC84		
PIN No.	DESCRIPTION	VOLTAGE
1	INPUT	10.3
2	GND	0.6
3	OUTPUT	5.6

IC92		
PIN No.	DESCRIPTION	VOLTAGE
1	VOUT	5
2	GND	0
3	VCC	5

IC93		
PIN No.	DESCRIPTION	VOLTAGE
1	OUT	5
2	VDD	5
3	GND	0

IC51			
PIN No.	DESCRIPTION	FM	AM
1	FM IF IN	2.4	1
2	IF BYPASS	2.4	1
3	IF BYPASS	2.4	1
4	GND	0	0
5	FM DET OUT	10.7	10.7
6	FM DET IN	10.7	10.7
7	VCC	10.7	10.7
8	TUNED	0	0
9	AFC	3.7	3.7
10	FM IF		N.C
11	AM IF		N.C
12	FM OUT	3.2	3.1
13	STRQ		N.C
14	AM NARROW	1.2	1.2
15	AM OUT	1.5	2.0
16	FM ADJ	1.5	0.6
17	AM ADJ	0	1.2
18	AM DET IN	2.4	2.0
19	AM AGC	1.5	1.4
20	AM DET OUT	0	10.7
21	AM RF IN	3.9	3.6
22	V REG	3.9	3.6
23	AM OSC IN	3.9	3.6
24	AM OSC OUT	3.2	2.2

IC62 (RDS)		
PIN No.	DESCRIPTION	VOLTAGE
1	DK FILTER	1.6
2	Q - DET	1.5
3	RDS ADJ	N.C
4	I - DET	1.4
5	B.P.F CHECK	2.3
6	RDS IN	2.4
7	SK FILTER	2.8
8	RDS FILTER	1.2
9	PLL LOOP FILTER	1.5
10	PLL LOOP FILTER	0
11	FILTER ADJ	0.7
12	GND	0
13	DK - IND	N.C
14	SK - IND	N.C
15	RDS - IND	N.C
16	SK - ADJ	0
17	DATA OUT	DATA
18	CLOCK	CLOCK
19	D - PLL	1.5
20	INTEG/D	1.1
21	B.P.F	2.1
22	B.P.F	2.1
23	VCC	4.3
24	456KHz OSC	456KHz OSC

IC53			
PIN No.	DESCRIPTION	FM	AM
1	X IN	7.2MHz	
2	X OUT	7.2MHz	
3	CE	CE	
4	CL	CL	
5	DATA	DATA	
6	SYC	N.C	
7	OUT 1	N.C	
8	OUT 2	0	10.7
9	OUT 3	0	3.9
10	AM OSC IN	AM OSC	
11	FM OSC IN	FM OSC	
12	VDD 1	4.8	
13	VDD 2	4.8	
14	PD 1	N.C	
15	PD 2	1.2	
16	GND	0	

IC52		
PIN No.	DESCRIPTION	VOLTAGE
1	VCC	9.7
2	MPX IN	2.4
3	COMP. AMP OUT	1.7
4	L - OUT	1.5
5	R - OUT	1.5
6	STEREO LED	5
7	GND	0
8	SEPA. ADJ	0.5
9	VCO STOP	0.8
10	PILOT FILTER	1.4
11	PILOT FILTER	1.4
12	19KHz CHECK	1
13	PLL IN	1.4
14	PLL FILTER	1.4
15	PLL FILTER	1.4
16	VCO	0.8

WIRING DIAGRAM

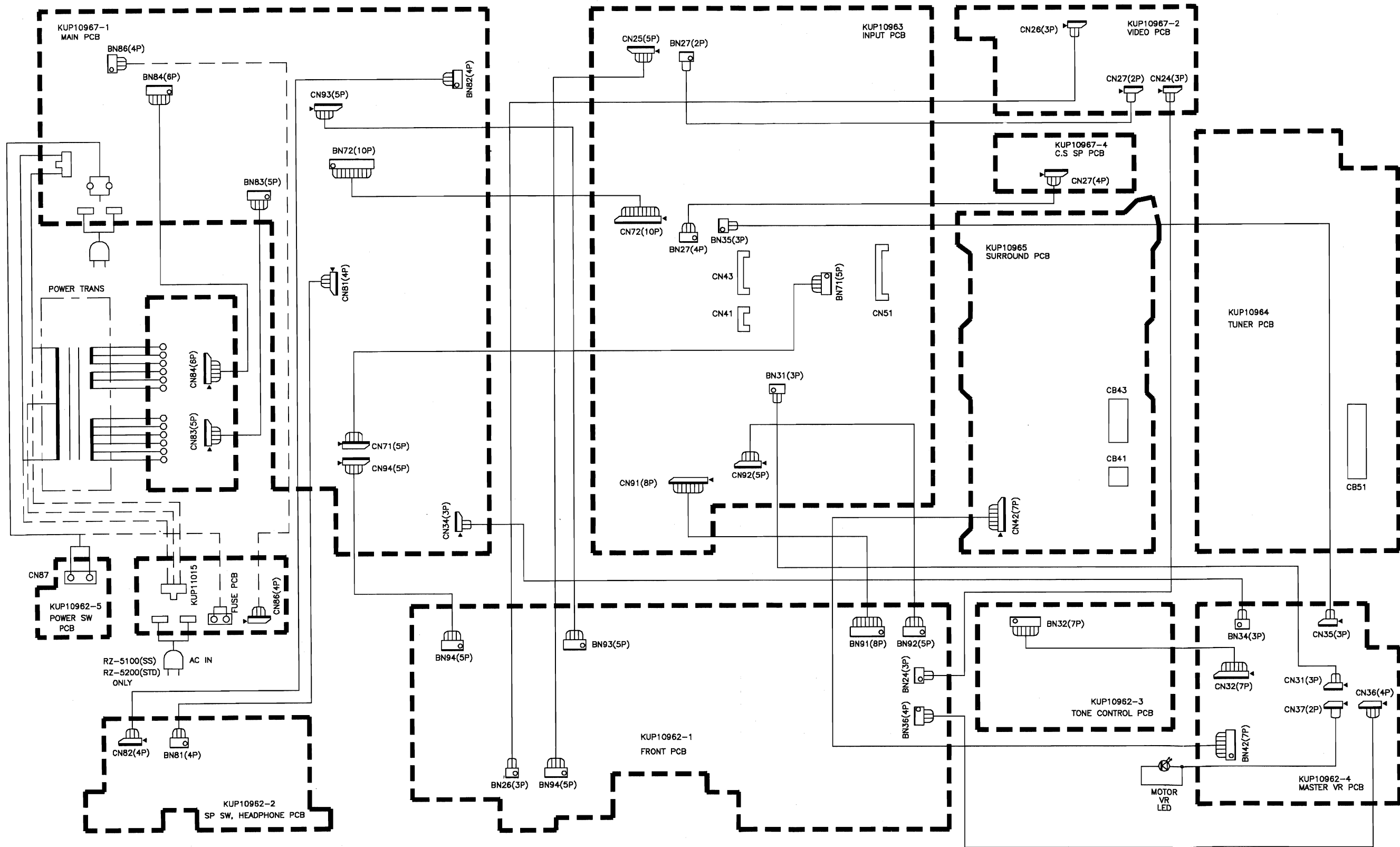

BLOCK DIAGRAM (TUNER)

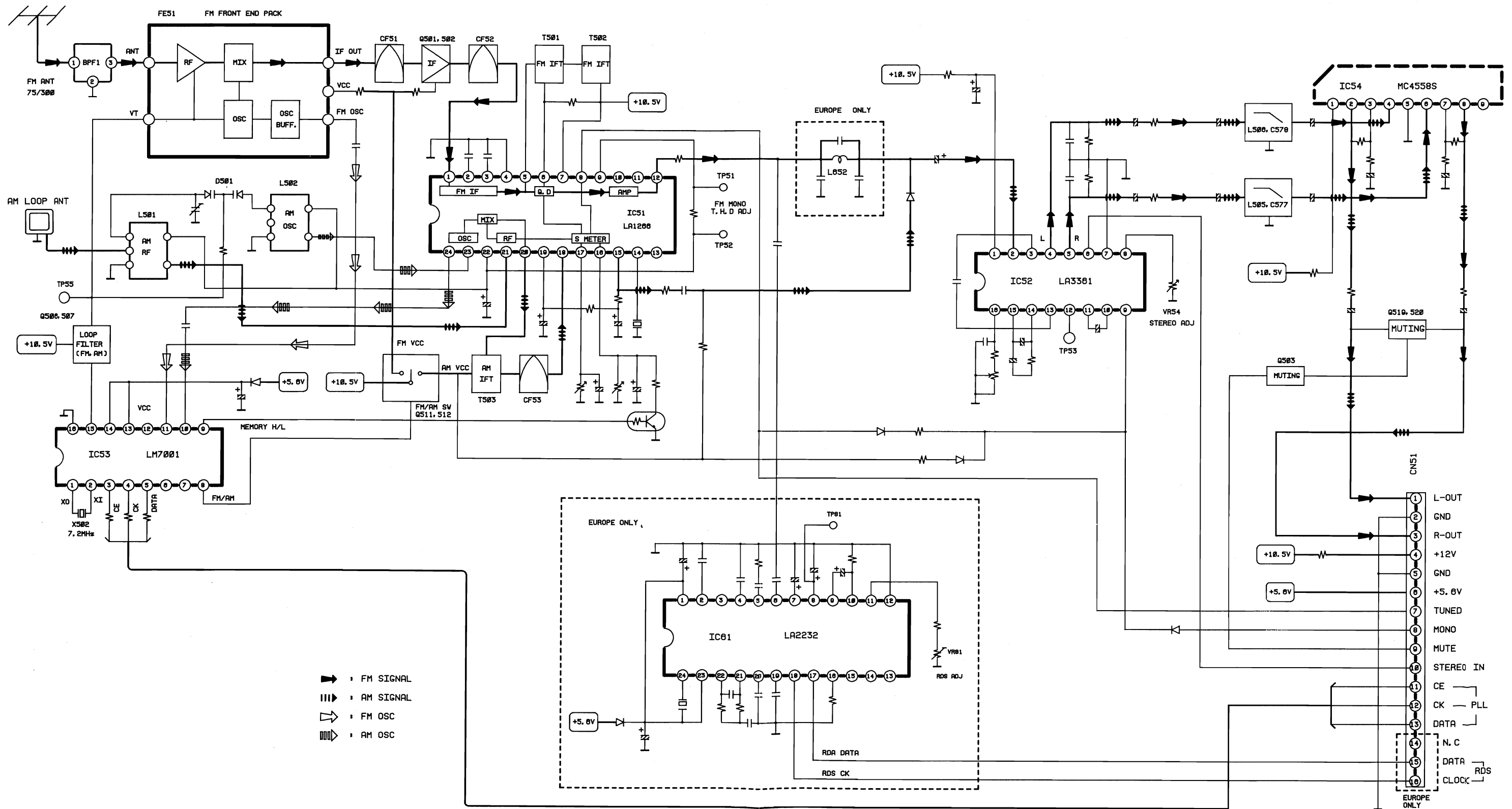

BLOCK DIAGRAM

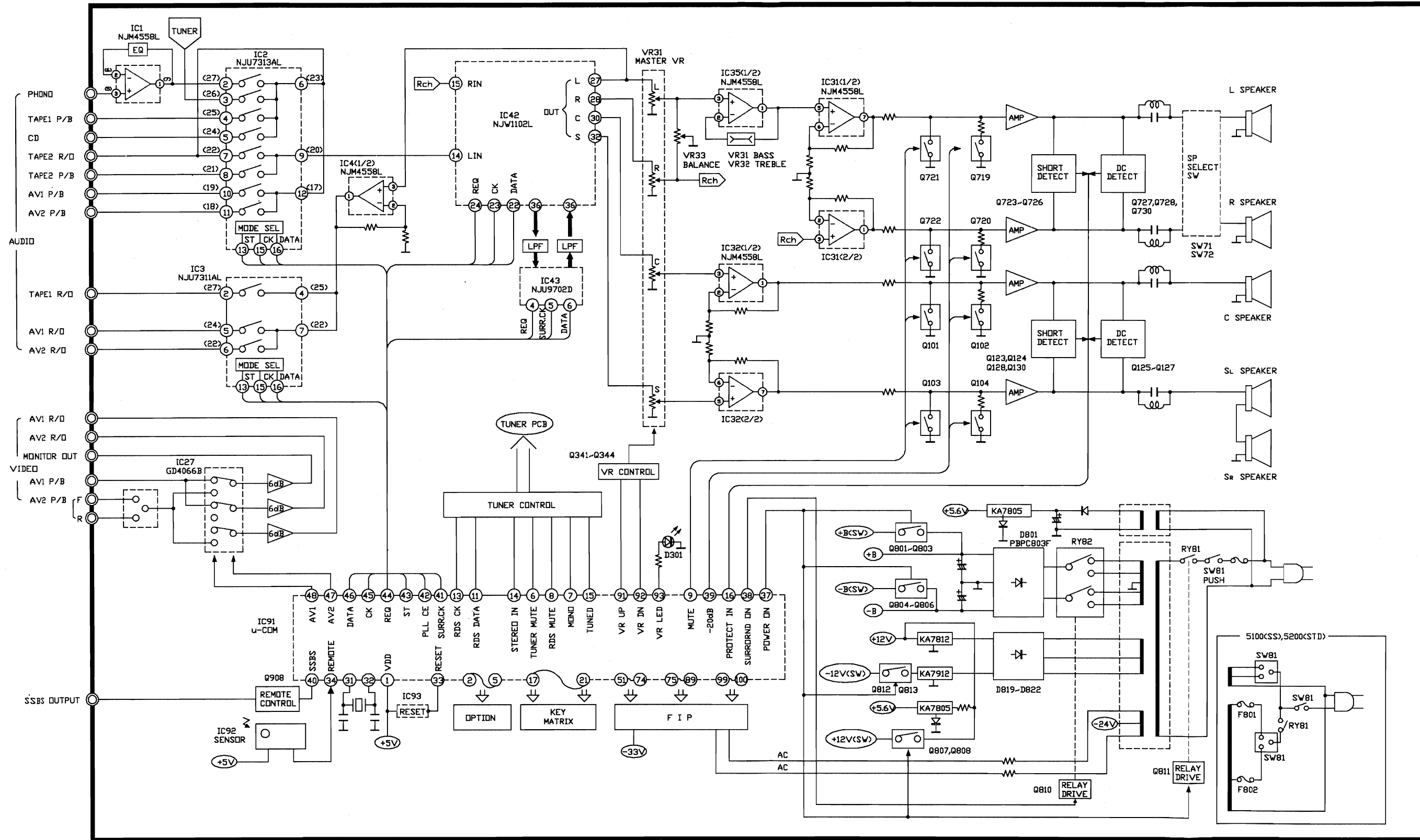

SCHEMATIC DIAGRAM (TUNER)

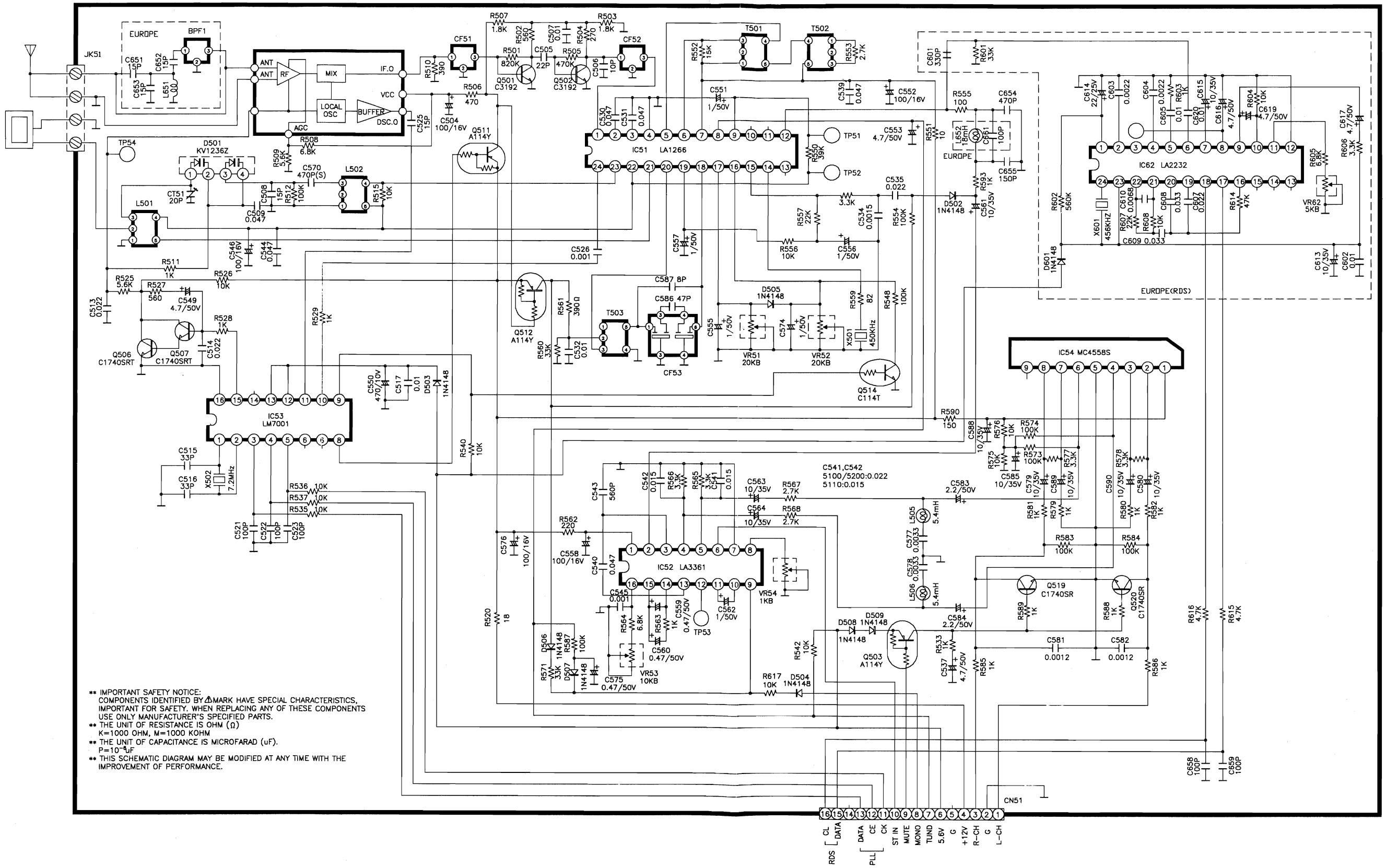

** IMPORTANT SAFETY NOTICE:
 COMPONENTS IDENTIFIED BY Δ MARK HAVE SPECIAL CHARACTERISTICS.
 IMPORTANT FOR SAFETY. WHEN REPLACING ANY OF THESE COMPONENTS
 USE ONLY MANUFACTURER'S SPECIFIED PARTS.
 ** THE UNIT OF RESISTANCE IS OHM (Ω)
 K=1000 OHM, M=1000 KOHM
 ** THE UNIT OF CAPACITANCE IS MICROFARAD (μ F).
 P= 10^{-12} F
 ** THIS SCHEMATIC DIAGRAM MAY BE MODIFIED AT ANY TIME WITH THE
 IMPROVEMENT OF PERFORMANCE.

15 14 13 12 11 10 9 8 7 6 5 4 3 2 1
 CL DATA RDS DATA CE CK ST IN MUTE MONO TUNED G +12V R-CH G L-CH

SCHEMATIC DIAGRAM (MAIN)

- IMPORTANT SAFETY NOTICE: COMPONENTS IDENTIFIED BY Δ MARK HAVE SPECIAL CHARACTERISTICS. IMPORTANT FOR SAFETY, WHEN REPLACING ANY OF THESE COMPONENTS USE ONLY MANUFACTURER'S SPECIFIED PARTS.
- THE UNIT OF RESISTANCE IS OHM (Ω)
K=1000 OHM, M=1000 KOHM
- THE UNIT OF CAPACITANCE IS MICROFARAD (μ F).
P=10⁻¹² μ F
- THIS SCHEMATIC DIAGRAM MAY BE MODIFIED AT ANY TIME WITH THE IMPROVEMENT OF PERFORMANCE.

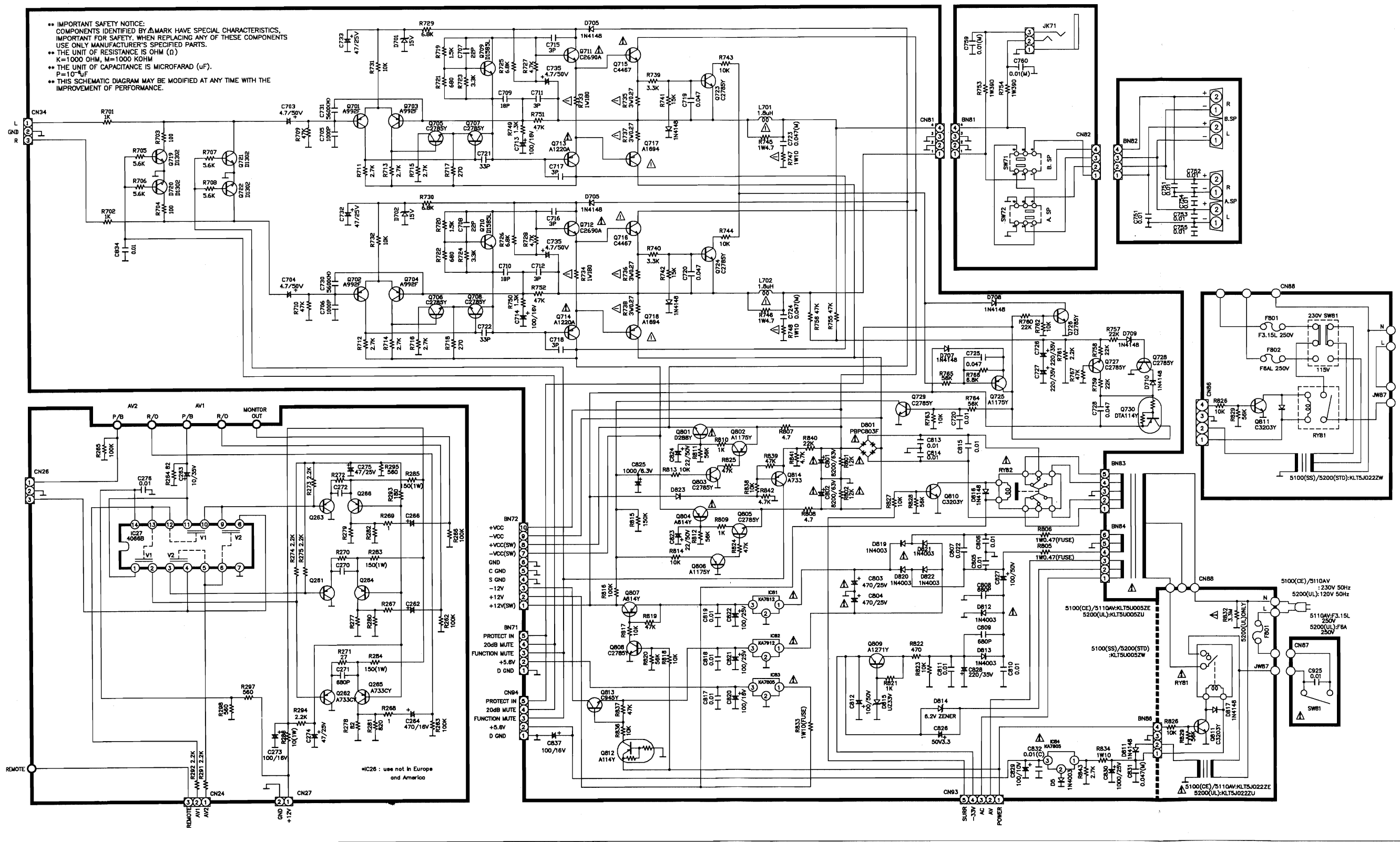

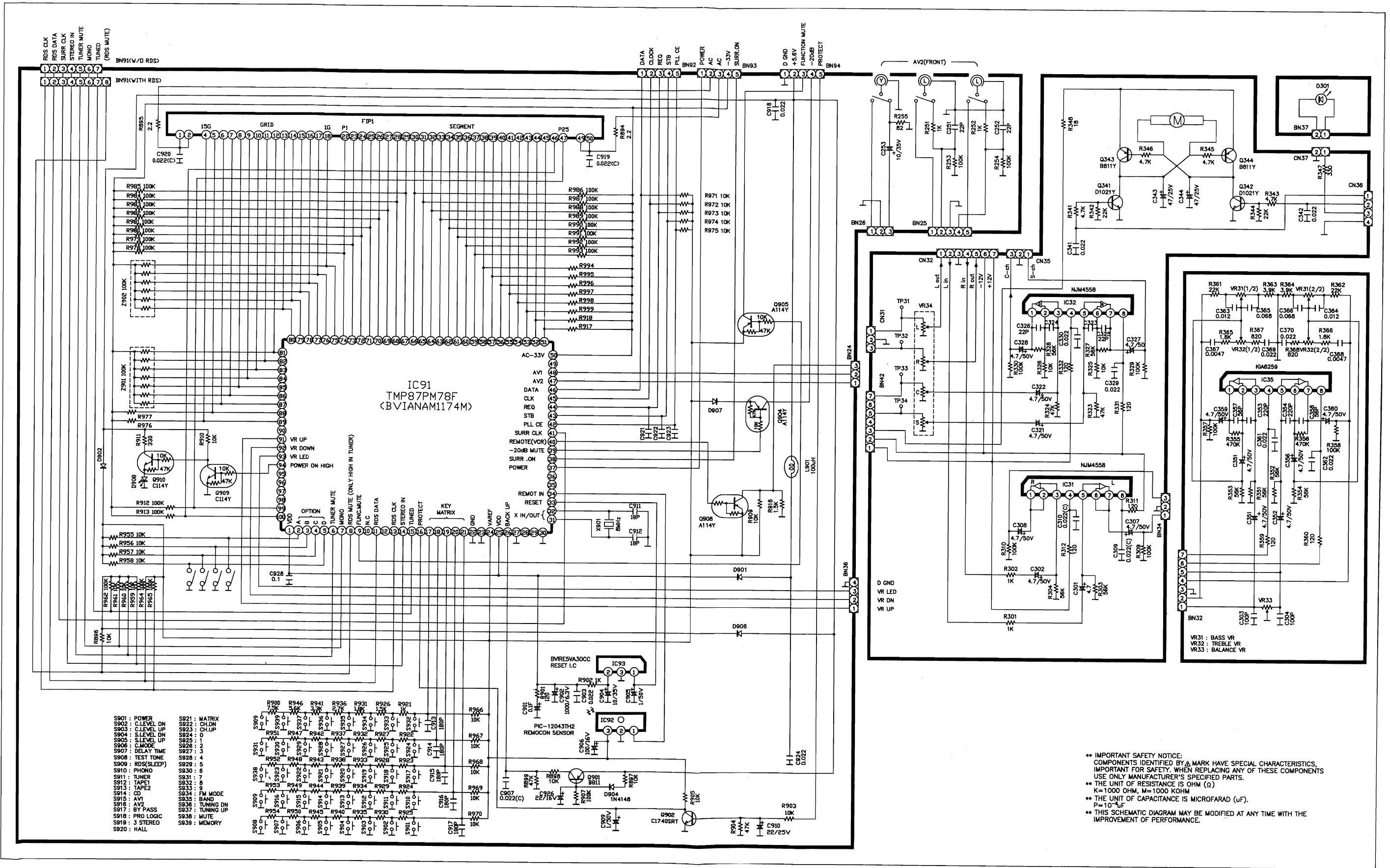

SCHEMATIC DIAGRAM (SURROUND)

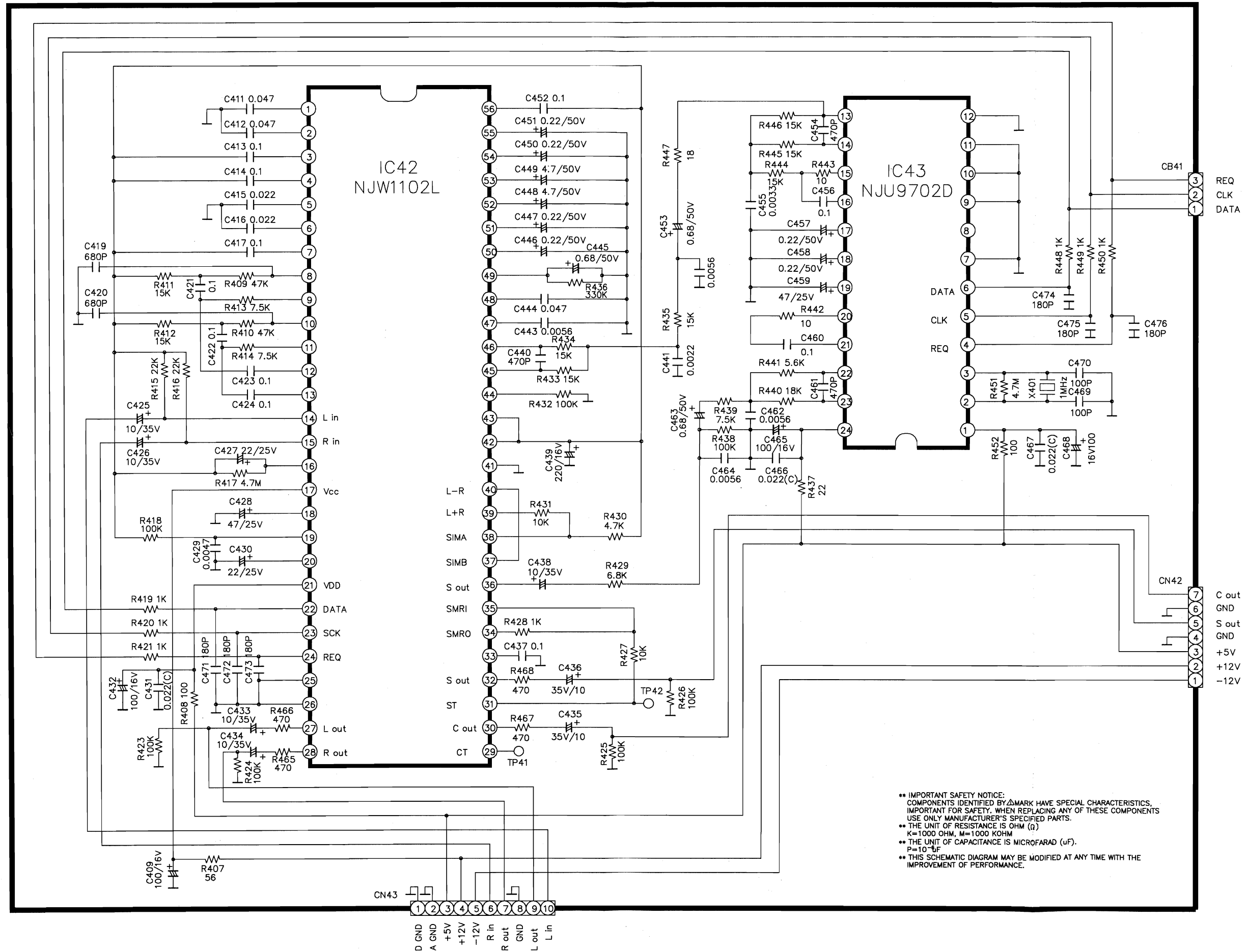

SCHEMATIC DIAGRAM (INPUT)

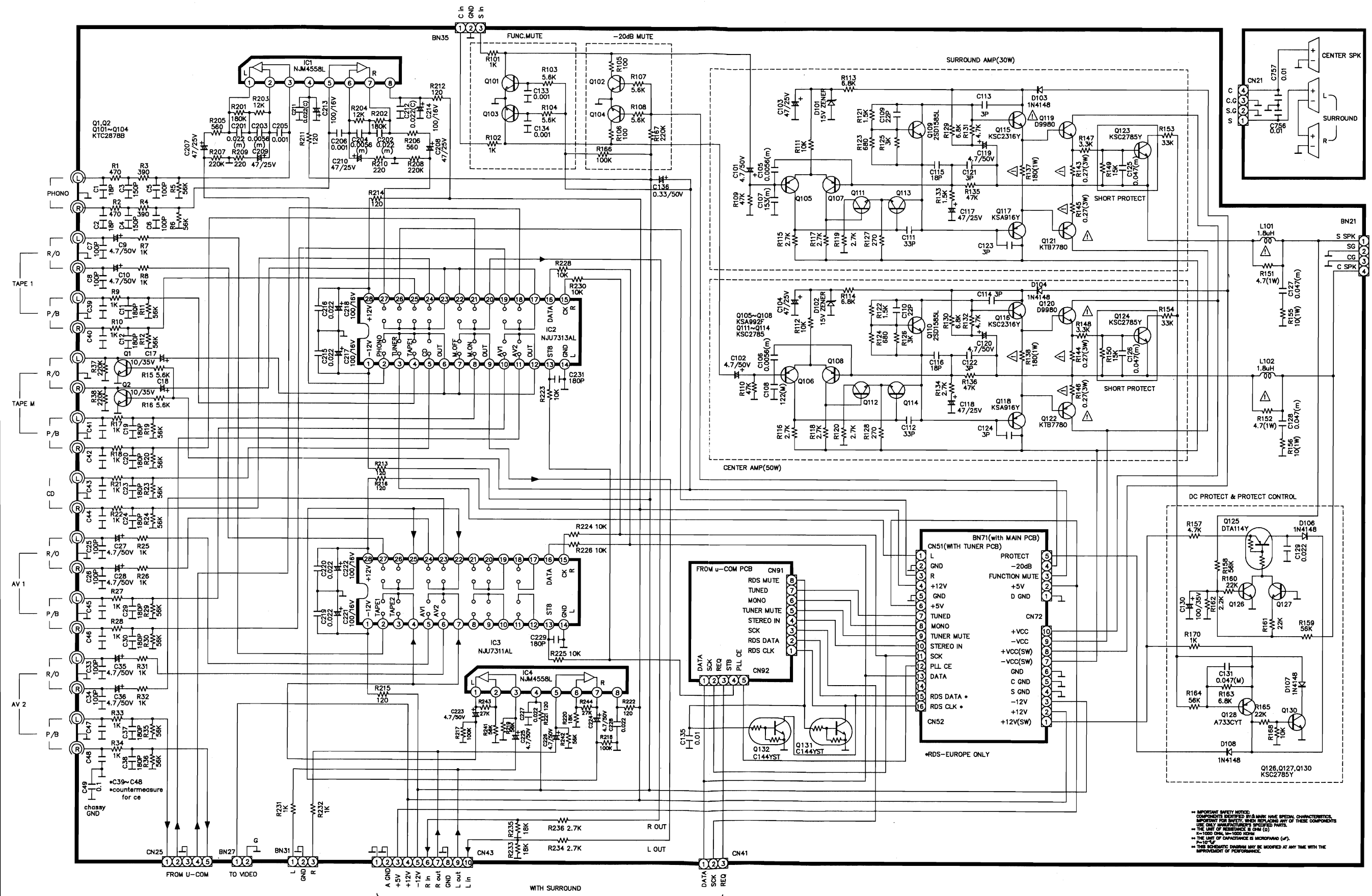

IMPORTANT SAFETY NOTICE:
 COMPONENTS IDENTIFIED BY THIS MARKING SYSTEM MAY HAVE SPECIAL CHARACTERISTICS. IMPORTANT FOR SAFETY, WHEN REPLACING ANY OF THESE COMPONENTS, USE ONLY MANUFACTURERS SPECIFIED PARTS.
 * THE LIMIT OF RESISTANCE IS OHM (Ω)
 * 1=100 OHM, 1K=1000 OHM
 * THE LIMIT OF CAPACITANCE IS MICROFARAD (μF), 1=10 μF
 * THIS SCHEMATIC DIAGRAM MAY BE MODIFIED AT ANY TIME WITH THE IMPROVEMENT OF PERFORMANCE.

SCHEMATIC DIAGRAM (REMOCON)

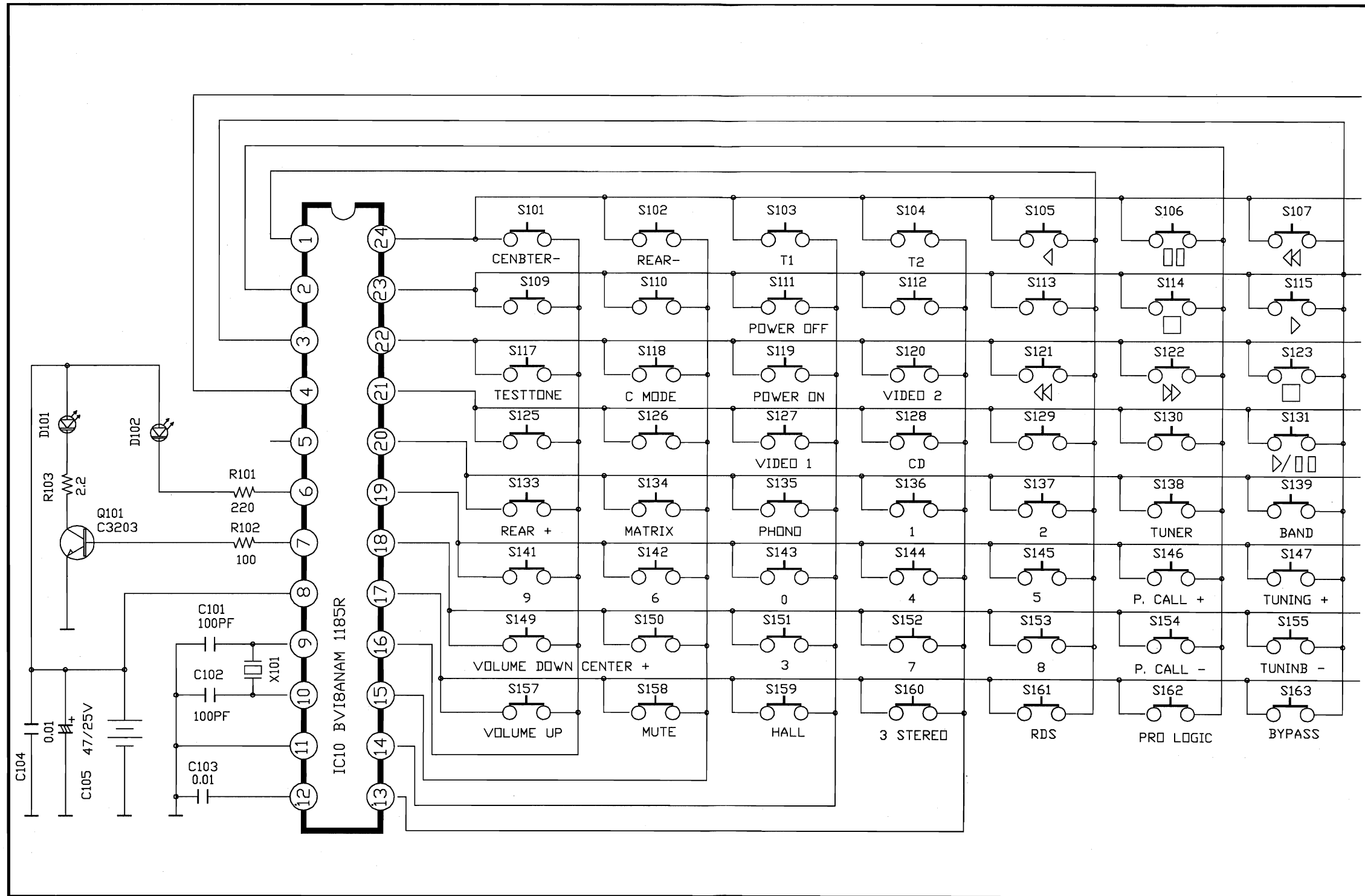

PRINTED CIRCUIT BOARDS

TUNER PCB

FUSE PCB

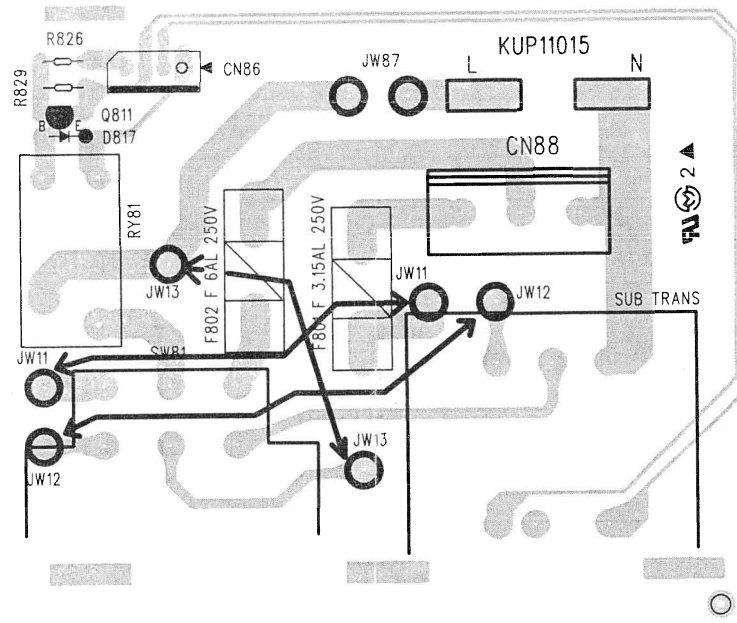

SURROUND PCB

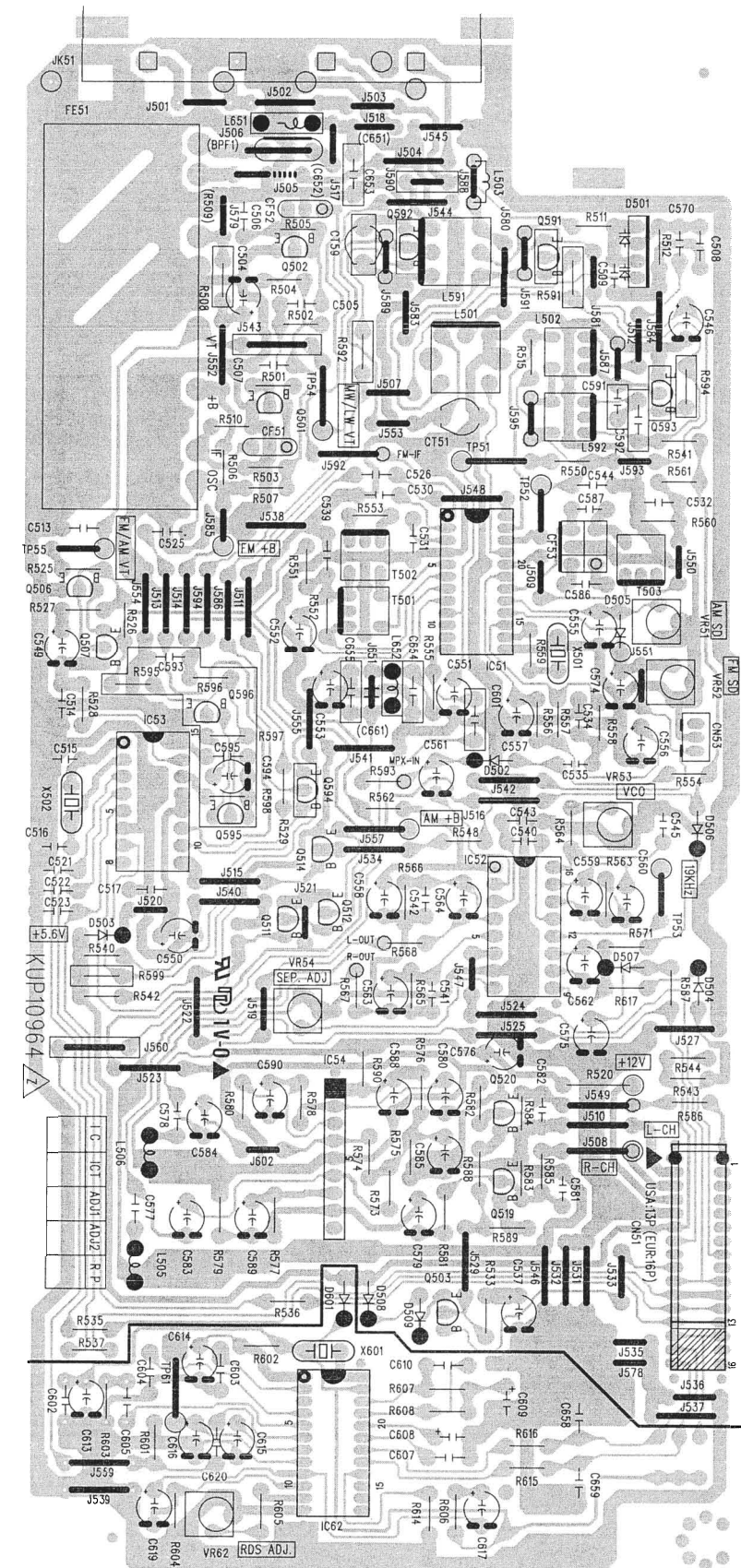
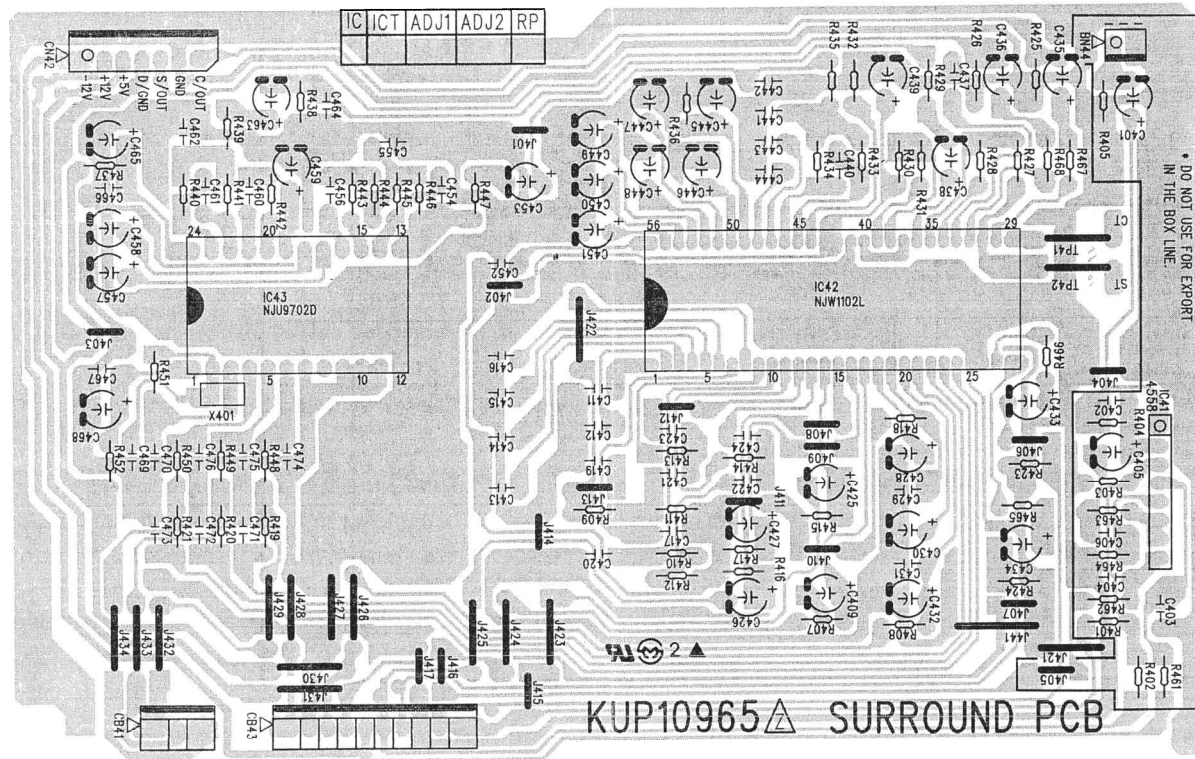

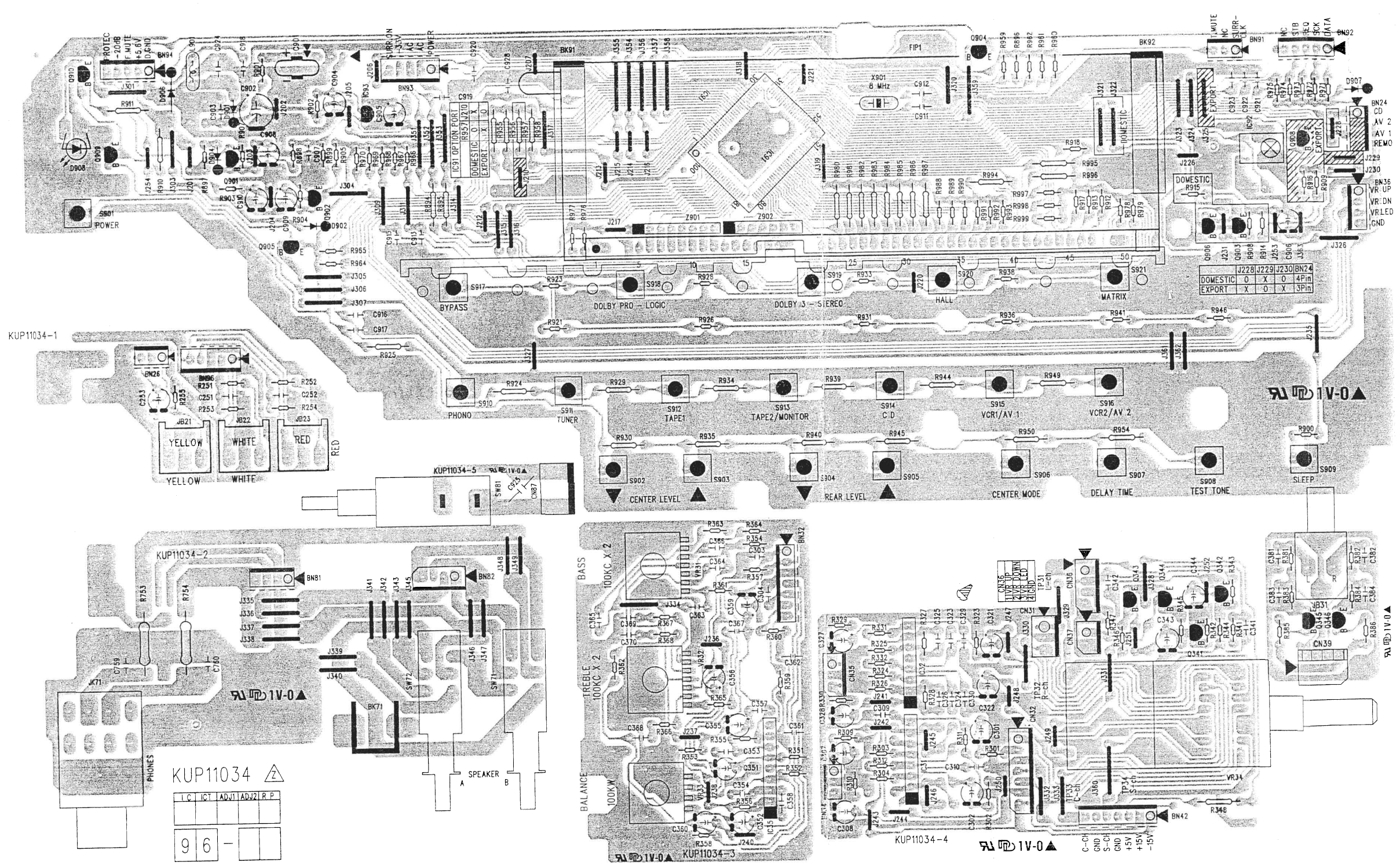

KUP11034

C	IC	AD-1	AD-2	R	P
9	6	-			

AV-5100 (FRONT PCB)

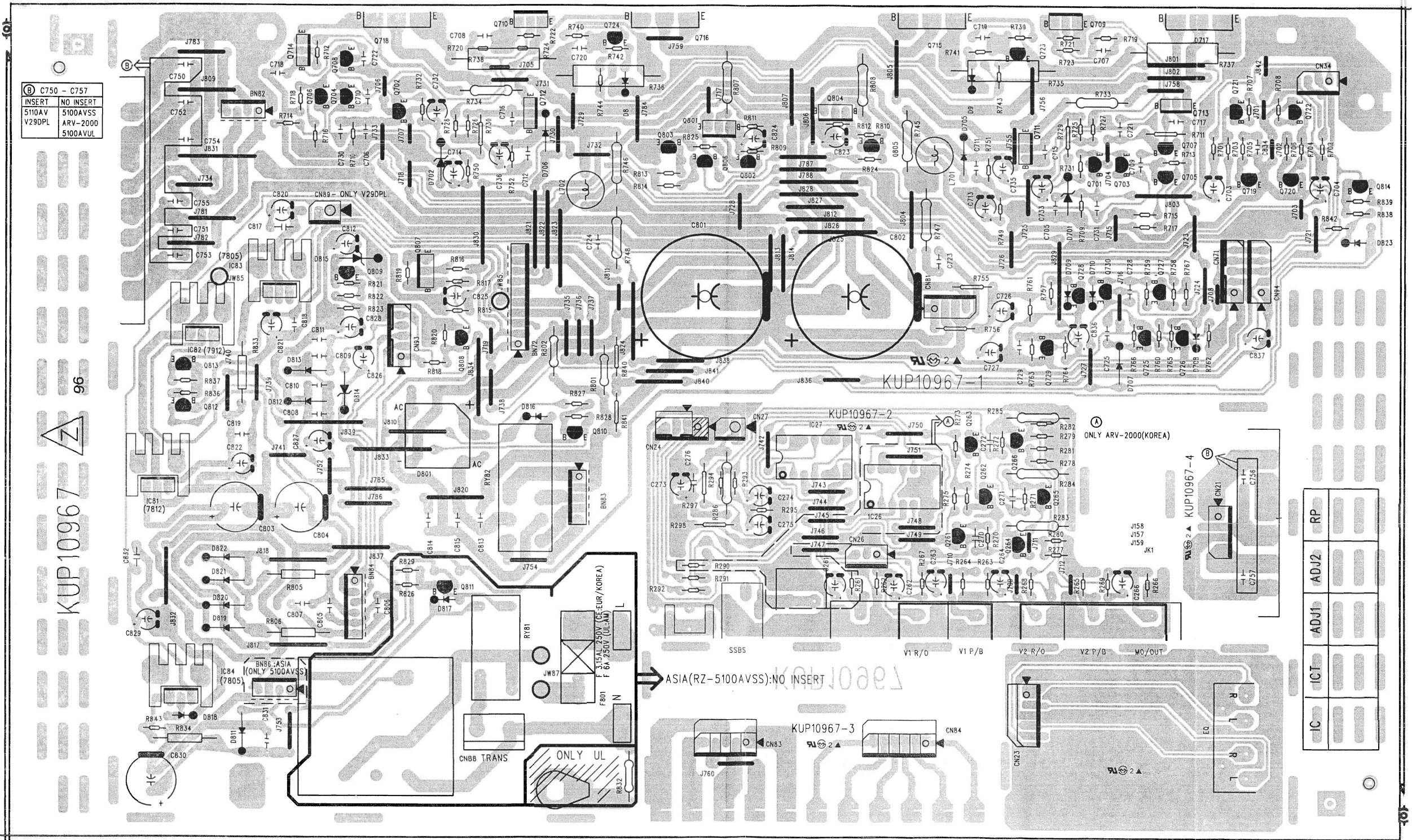

FRONT PCB

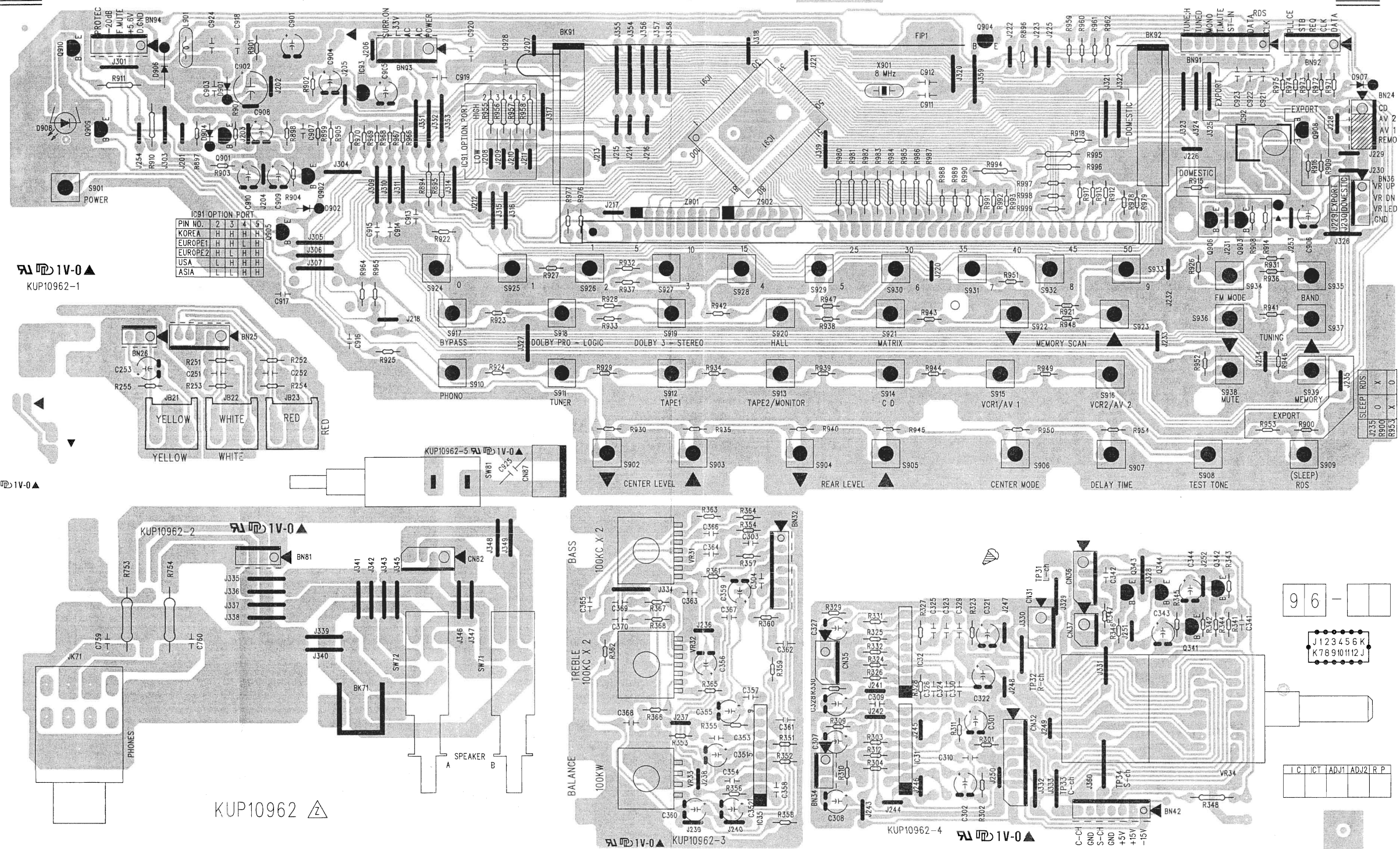

IC91 OPTION PORT

PIN NO.	1	2	3	4	5
KOREA	H	H	H	H	H
EUROPE1	H	H	H	H	H
EUROPE2	H	L	H	H	H
USA	L	L	H	H	H
ASIA	L	L	L	H	H

(SLEEP) ROS	J335	0	X	0
EXP	R900	0	X	0
EXP	R901	X	0	0

KUP10962

INPUT PCB

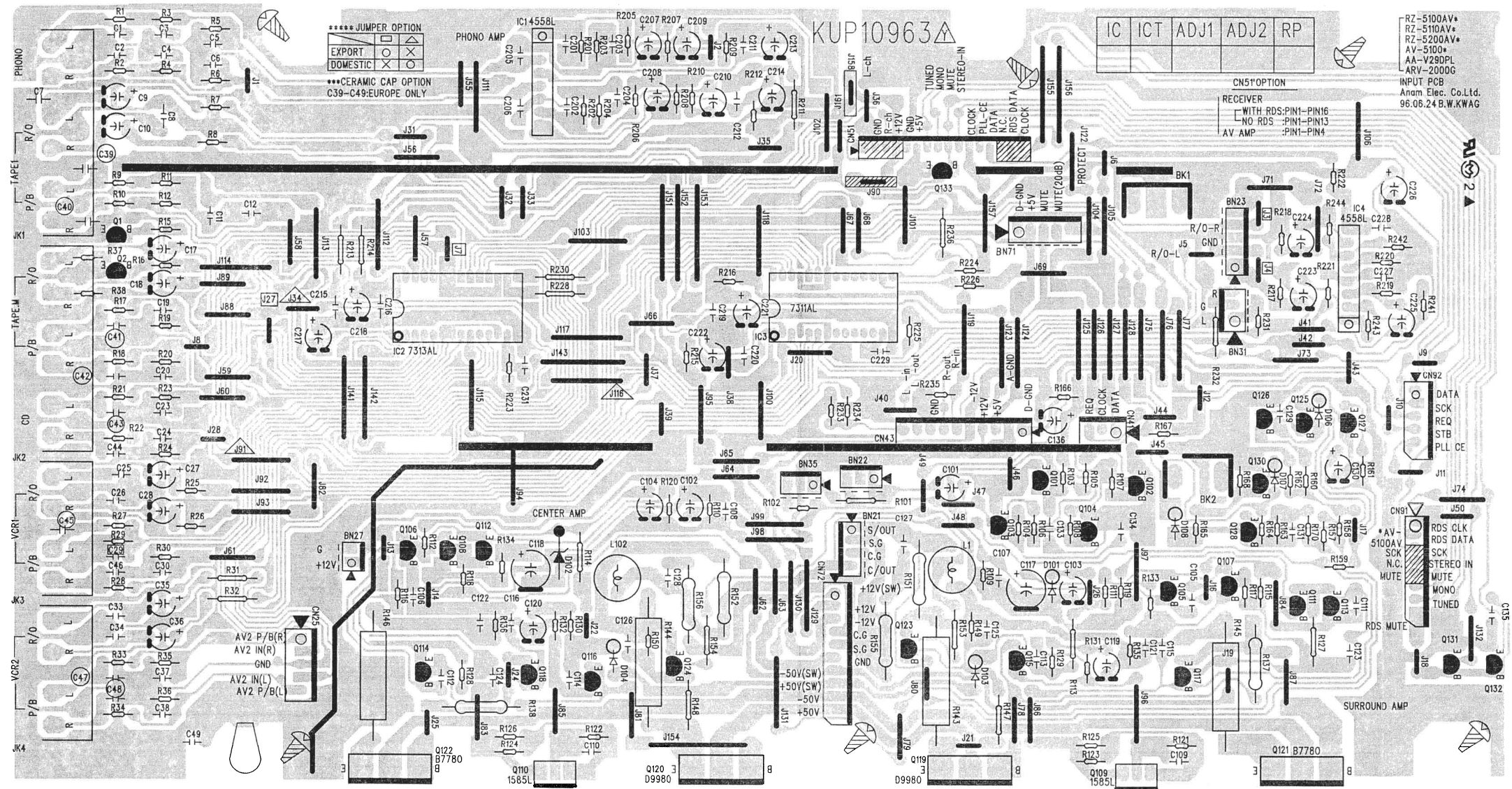

EXPLODED VIEW (RZ-5100AV)

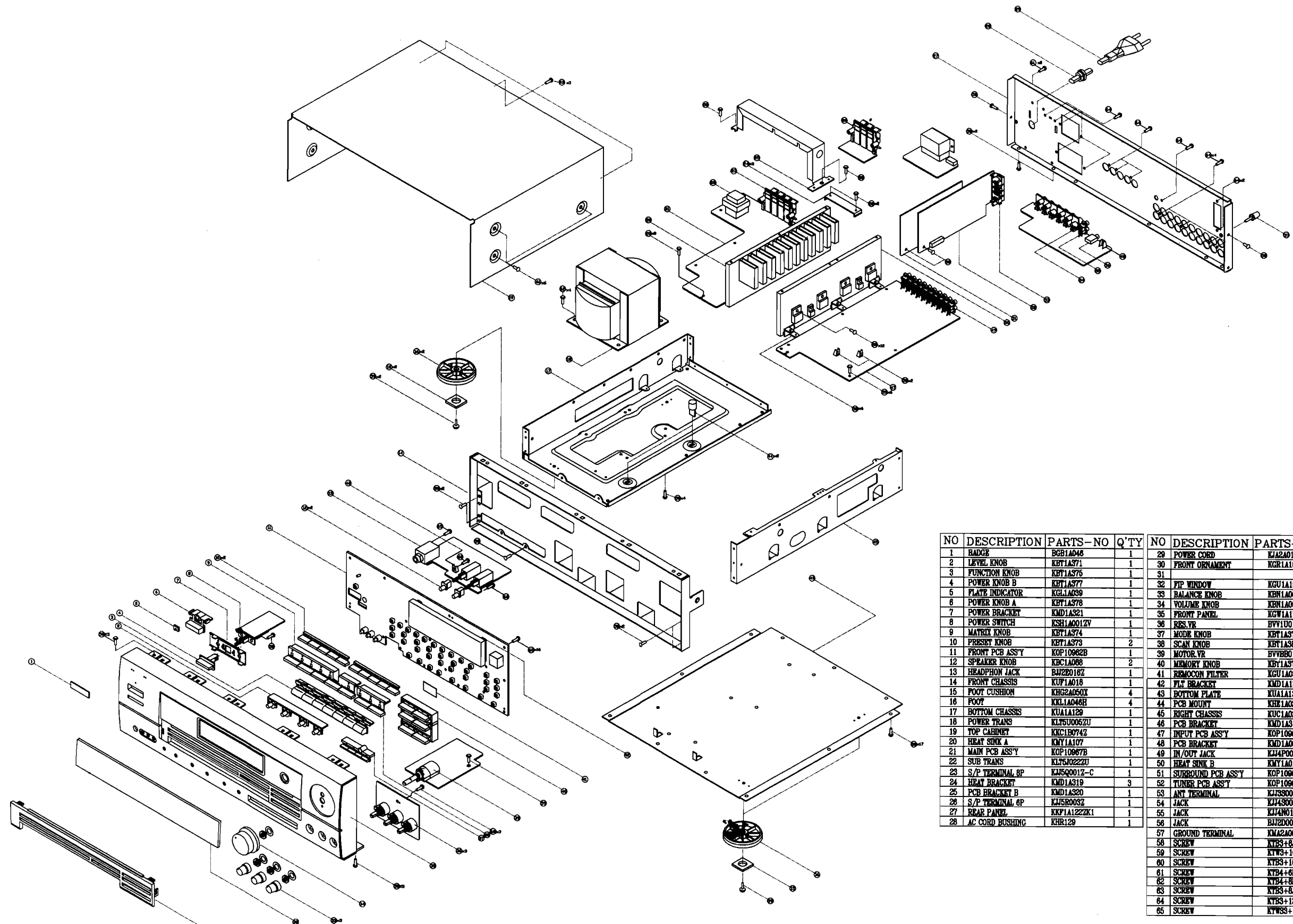

NO	DESCRIPTION	PARTS-NO	Q'TY	NO	DESCRIPTION	PARTS-NO	Q'TY
1	RADGE	BGB1A046	1	29	POWER CORD	KJA2A013Z	1
2	LEVEL KNOB	KBT1A371	1	30	FRONT ORNAMENT	KGR1A101Z	1
3	FUNCTION KNOB	KBT1A376	1	31			
4	POWER KNOB B	KBT1A377	1	32	FIP WINDOW	KGU1A151Z	1
5	PLATE INDICATOR	KGL1A039	1	33	BALANCE KNOB	KBN1A067	3
6	POWER KNOB A	KBT1A378	1	34	VOLUME KNOB	KBN1A066	1
7	POWER BRACKET	KMD1A321	1	35	FRONT PANEL	KGW1A174	1
8	POWER SWITCH	KSH1A001ZV	1	36	RES.VR	BVY1D01W104Z	1
9	MATRIX KNOB	KBT1A374	1	37	MODE KNOB	KBT1A372	1
10	PRESSET KNOB	KBT1A373	2	38	SCAN KNOB	KBT1A381	1
11	FRONT PCB ASS'Y	KOP10962B	1	39	MOTOR.VR	BVYB801A104Z	1
12	SPEAKER KNOB	KBC1A068	2	40	MEMORY KNOB	KBY1A376	1
13	HEADPHON JACK	BJZ2D16Z	1	41	REMOCON FILTER	KGU1A026	1
14	FRONT CHASSIS	KUF1A018	1	42	FLT BRACKET	KMD1A127	1
15	FOOT CUSHION	KHGR2A050Y	4	43	BOTTOM PLATE	KUJ1A130	1
16	FOOT	KK1A1046H	4	44	PCB MOUNT	KHE1A023	1
17	BOTTOM CHASSIS	KUJ1A129	1	45	RIGHT CHASSIS	KUC1A029	1
18	POWER TRANS	KL75J005ZU	1	46	PCB BRACKET	KMD1A318	6
19	TOP CABINET	KKC1B074Z	1	47	INPUT PCB ASS'Y	KOP10963B	1
20	HEAT SINK A	KMY1A107	1	48	PCB BRACKET	KMD1A061	4
21	MAIN PCB ASS'Y	KOP10967B	1	49	IN/OUT JACK	KJ4P0022-K	1
22	SUB TRANS	KL75J022ZU	1	50	HEAT SINK B	KMY1A018	1
23	S/P TERMINAL 8P	KJ55Q001Z-C	1	51	SURROUND PCB ASS'Y	KOP10965B	1
24	HEAT BRACKET	KMD1A319	3	52	TUNER PCB ASS'Y	KOP10964	1
25	PCB BRACKET B	KMD1A320	1	53	ANT TERMINAL	KJ3S006Z	1
26	S/P TERMINAL 6P	KJ55R003Z	1	54	JACK	KJ4W006Z	1
27	REAR PANEL	KK71A122ZK1	1	55	JACK	KJ4W010Z	1
28	AC CORD BUSHING	KHR129	1	56	JACK	BJZD003Z	1
				57	GROUND TERMINAL	KMA2A001	1
				58	SCREW	KYB3+8J	46
				59	SCREW	KYB3+10J	11
				60	SCREW	KYB3+10C	21
				61	SCREW	KYB4+6PFZ	6
				62	SCREW	KYB4+8P	4
				63	SCREW	KYB3+8PFZ	9
				64	SCREW	KYB3+120PFZ	15
				65	SCREW	KYB33+10C	1

EXPLODED VIEW (RZ-5110AV)

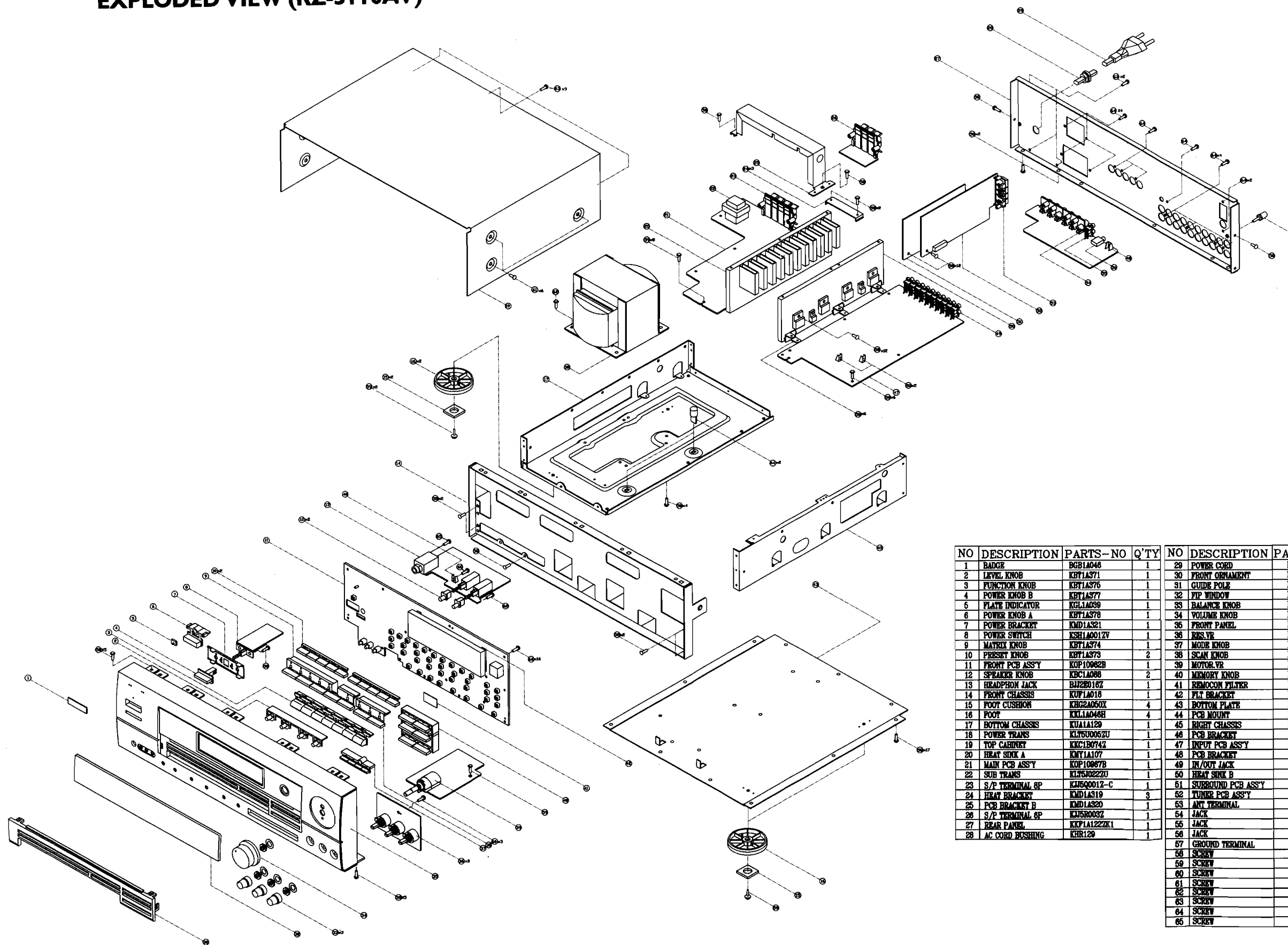

NO	DESCRIPTION	PARTS-NO	Q'TY	NO	DESCRIPTION	PARTS-NO	Q'TY
1	BADGE	BGB1A046	1	29	POWER CORD	KJA2A013Z	1
2	LEVEL KNOB	KBT1A571	1	30	FRONT ORNAMENT	KGR1A101Z	1
3	FUNCTION KNOB	KBT1A576	1	31	GUIDE POLE	KDP1A015	2
4	POWER KNOB B	KBT1A577	1	32	VIP WINDOW	KGU1A151Z	1
5	PLATE INDICATOR	KGL1A058	1	33	BALANCE KNOB	KBN1A087	3
6	POWER KNOB A	KBT1A578	1	34	VOLUME KNOB	KBN1A055	1
7	POWER BRACKET	KMD1A521	1	35	FRONT PANEL	KGV1A174	1
8	POWER SWITCH	KSH1A001ZV	1	36	RES.VR	BVY1D01W104Z	1
9	MATRIX KNOB	KBT1A574	1	37	MODE KNOB	KBT1A572	1
10	PRESET KNOB	KBT1A573	2	38	SCAN KNOB	KBT1A581	1
11	FRONT PCB ASS'Y	KOP10982B	1	39	MOTOR.VR	BVVB01A104Z	1
12	SPEAKER KNOB	KBC1A088	2	40	MEMORY KNOB	KBT1A576	1
13	HEADPHN JACK	BJJ2E018Z	1	41	REMCON FILTER	KGU1A026	1
14	FRONT CHASSIS	KUF1A018	1	42	FLT BRACKET	KMD1A127	1
15	FOOT CUSHION	KHC2A050X	4	43	BOTTOM PLATE	KU1A130	1
16	FOOT	KK1A046H	4	44	PCB MOUNT	KHE1A023	1
17	BOTTOM CHASSIS	KU1A129	1	45	RIGHT CHASSIS	KUC1A029	1
18	POWER TRANS	KL76U0062U	1	46	PCB BRACKET	KMD1A318	6
19	TOP CABINET	KKC1B074Z	1	47	INPUT PCB ASS'Y	KOP10965B	1
20	HEAT SINK A	KMY1A107	1	48	PCB BRACKET	KOP1A081	4
21	MAIN PCB ASS'Y	KOP10987B	1	49	IN/OUT JACK	KJ4P002Z-K	1
22	SUB TRANS	KL76U0222U	1	50	HEAT SINK B	KMY1A018	1
23	S/P TERMINAL 8P	KJ5G001Z-C	1	51	SURROUND PCB ASS'Y	KOP10965B	1
24	HEAT BRACKET	KMD1A319	3	52	TUNER PCB ASS'Y	KOP10964	1
25	PCB BRACKET B	KMD1A320	1	53	ANT TERMINAL	KJ3S006Z	1
26	S/P TERMINAL 6P	KJ5R003Z	1	54	JACK	KJ4S005Z	1
27	REAR PANEL	KKP1A1222K1	1	55	JACK	KJ4N010Z	1
28	AC CORD BUSHING	KHR129	1	56	JACK	BJJ2E003Z	1
				57	GROUND TERMINAL	KMA2A001	1
				58	SCREW	KYB3+6J	46
				59	SCREW	KYB3+10J	11
				60	SCREW	KYB3+10G	21
				61	SCREW	KYB4+6PFZ	6
				62	SCREW	KYB4+8P	4
				63	SCREW	KYB3+8PFZ	9
				64	SCREW	KYB3+12CFZ	15
				65	SCREW	KYB3+10G	1

EXPLODED VIEW (RZ-5200AV)

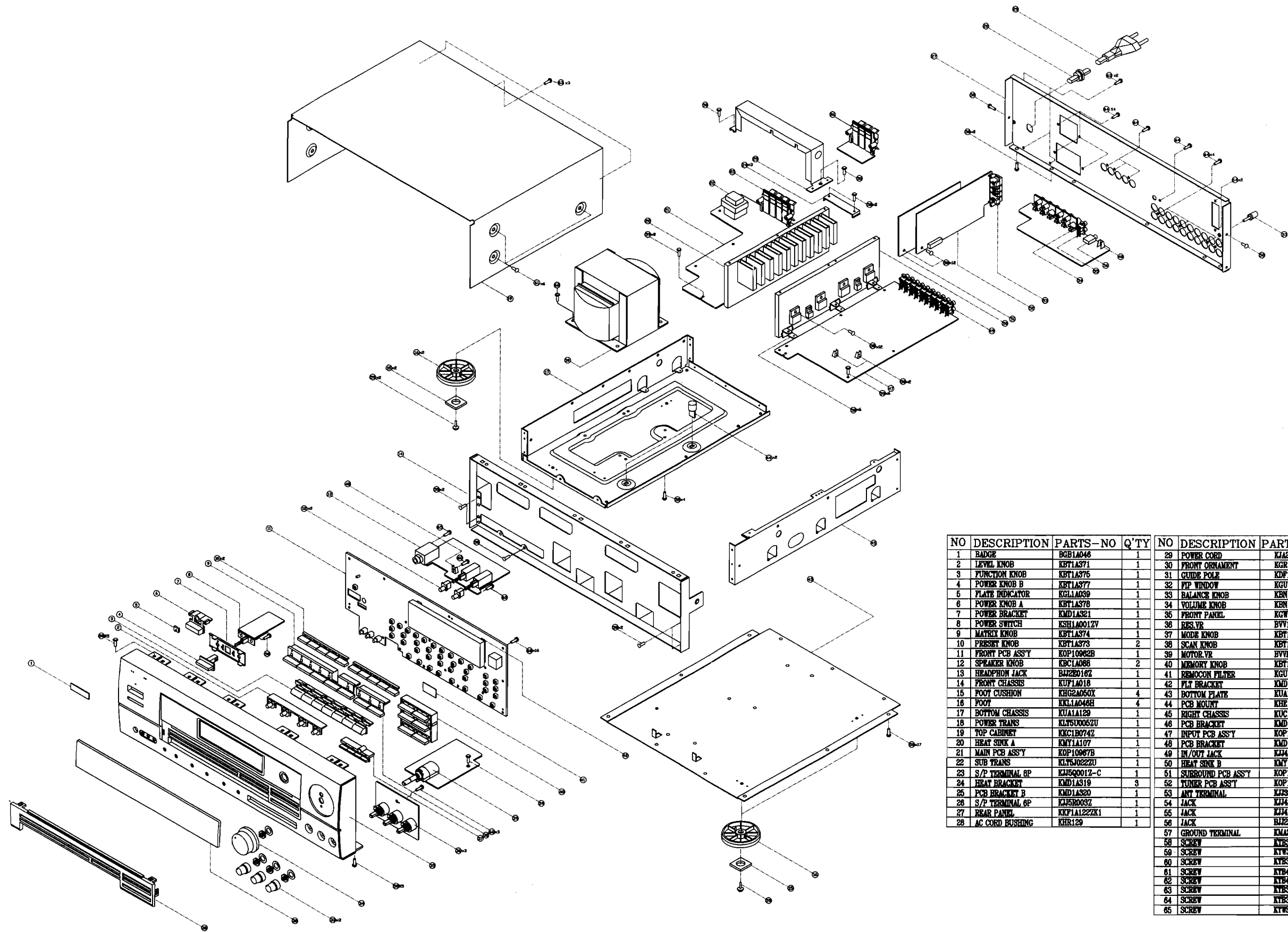

NO	DESCRIPTION	PARTS-NO	Q'TY	NO	DESCRIPTION	PARTS-NO	Q'TY
1	RADGE	BGB1A046	1	29	POWER CORD	KJA2A013Z	1
2	LEVEL KNOB	KBT1A371	1	30	FRONT ORNAMENT	KGR1A101Z	1
3	FUNCTION KNOB	KBT1A376	1	31	GUIDE POLE	KDF1A015	2
4	POWER KNOB B	KBT1A377	1	32	PIP WINDOW	KGU1A161Z	1
5	PLATE INDICATOR	KGL1A039	1	33	BALANCE KNOB	KBN1A067	3
6	POWER KNOB A	KBT1A378	1	34	VOLUME KNOB	KBN1A066	1
7	POWER BRACKET	KMD1A321	1	35	FRONT PANEL	KCV1A174	1
8	POWER SWITCH	KSH1A001ZV	1	38	RES.VR	BVY1U01W104Z	1
9	MATRIX KNOB	KBT1A374	1	37	MODE KNOB	KBT1A372	1
10	PRESET KNOB	KBT1A373	2	38	SCAN KNOB	KBT1A381	1
11	FRONT PCB ASS'Y	KOP10662B	1	39	MOTOR.VR	BVYBB01A104Z	1
12	SPEAKER KNOB	KBC1A066	2	40	MEMORY KNOB	KBT1A376	1
13	HEADPHON JACK	BAJ2B016Z	1	41	MEMOCON FILTER	KGU1A026	1
14	FRONT CHASSIS	KUPLA018	1	42	FLT BRACKET	KMD1A127	1
15	FOOT CUSHION	KHG2A060X	4	43	BOTTOM PLATE	KUA1A130	1
16	FOOT	KK1A046H	4	44	PCB MOUNT	KHE1A023	1
17	BOTTOM CHASSIS	KUA1A129	1	45	RIGHT CHASSIS	KUC1A029	1
18	POWER TRANS	KLTSU0062U	1	46	PCB BRACKET	KMD1A318	6
19	TOP CABINET	KXC1B074Z	1	47	INPUT PCB ASS'Y	KOP10663B	1
20	HEAT SINK A	KMY1A107	1	48	PCB BRACKET	KMD1A061	4
21	MAIN PCB ASS'Y	KOP10667B	1	49	IN/OUT JACK	KJ4P002Z-K	1
22	SUB TRANS	KLTSJ022ZU	1	50	HEAT SINK B	KMY1A018	1
23	S/P TERMINAL 8P	KJ5Q001Z-C	1	51	SUBROUND PCB ASS'Y	KOP10665B	1
24	HEAT BRACKET	KMD1A319	3	52	TUNER PCB ASS'Y	KOP10664	1
25	PCB BRACKET B	KMD1A320	1	53	ANT TERMINAL	KJ5S006Z	1
26	S/P TERMINAL 8P	KJ5R003Z	1	54	JACK	KJ4S006Z	1
27	REAR PANEL	KKPLA122ZK1	1	55	JACK	KJ4N010Z	1
28	AC CORD BUSHING	KHR129	1	56	JACK	BU2B003Z	1
				57	GROUND TERMINAL	KMA2A001	1
				58	SCREW	KTB3+10J	46
				59	SCREW	KTB3+10J	11
				60	SCREW	KTB3+10G	21
				61	SCREW	KTB4+8PFZ	6
				62	SCREW	KTB4+8F	4
				63	SCREW	KTB3+8JPFZ	9
				64	SCREW	KTB3+12GFZ	15
				65	SCREW	KTB3+10G	1

PARTS LIST

ATTENTION

1. When placing an order for parts, be sure to list the Part No., Model No. and the description of each part. Otherwise, the non-delivery of the part or the delivery of a wrong part may result.
2. Please make sure that Part No. is correct when ordering.
If not, a part different from the one you ordered may be delivered.
3. Since the parts shown in Parts List of Preliminary Service Manual may have been the subject of changes, please use this Parts List for all future reference.

HOW TO USE THIS PARTS LIST

1. This Parts List lists those parts which are considered necessary for repairs. Other common parts, such as resistors and capacitors, are listed in the "Common List for Service Parts" from which these parts should be selected and stocked.
2. Parts not shown in the Parts List and "Common List for Service Parts" will not in principle be supplied.
3. How to read the Parts List.

■ Resistor and Capacitor

- Notes :
- Part numbers are indicated for most mechanical parts.
Please use this part number for parts order.
 - IMPORTANT SAFETY NOTICE.
Components identified by \triangle mark have special characteristics important for safety.
When replacing any of these components, use only manufacture's specified parts.
 - The unit of resistance is OHM(Ω)
K=1000(Ω), M=1000(K Ω)
 - The unit of capacitance is MICROFARAD(μ F).
P=10⁻⁶ μ F

■ Numbering System of Resistor

Example

$\frac{KRD}{Type} \quad \frac{25}{Wattage} \quad \frac{F}{Shape} \quad \frac{J}{Tolerance} \quad \frac{101}{Value}$

Resistor Type	Wattage	Tolerance
KRD:Carbon	20:1/5W	F:= \pm 1%
KRG:Metal Oxide	25:1/4W 50:1/2W 1:1W	J:= \pm 5% K:= \pm 10%
KRF:Metal Cement	2:2W 3:3W	

■ Numbering System of Capacitor

Example

$\frac{KCKR}{Type} \quad \frac{1H}{Voltage} \quad \frac{101}{Value} \quad \frac{K}{Tolerance} \quad \frac{B}{Peculiarity}$

Capacitor Type	Voltage		Tolerance
	ECEA Type	Other	
KCB: Ceramic	OJ:6.3V	1H:50V DC	C: \pm 0.25pF
KCC: Ceramic	1A:10V	1:125V DC	G: \pm 2%
KCK: Ceramic	1C:16V	KC:400V AC	J: \pm 5%
KCFR: Semiconductor	1E:25V		K: \pm 10%
KCQI: Polyester	1H:50V		Z: +80%, -20%
KCQP: Polypropylene	1V:35V		
KCQS: Polystyrol			

WARNING

\triangle (*) INDICATES SAFETY CRITICAL COMPONENTS. FOR CONTINUED SAFETY, REPLACE SAFETY CRITICAL COMPONENTS ONLY WITH MANUFACTURE'S RECOMMENDED PARTS.

AVERTISSEMENT

\triangle (*) IL INDIQUE LES COMPOSANTS CRITIQUES DE SÉCURITÉ. POUR MAINTENIR LE DEGRÉ DE SÉCURITÉ DE L'APPAREIL, NE REMPLACER QUE DES PIÈCES RECOMMANDÉES PAR LE FABRICANT.

ELECTRICAL PARTS LIST

REF.No.	PART No.	DESCRIPTION	REF.No.	PART No.	DESCRIPTION
P.C BOARD BLOCK PART No.			D908	KVD342VCF02T085	L.E.D, RED
	PART No.	DESCRIPTION	BN24	KWZRZ5100AV24	WIRE ASS'Y
	1. KOP10962	FRONT PCB ASS'Y	BN25	KWZRZ5100AV25	WIRE ASS'Y
	2. KOP10963	INPUT PCB ASS'Y	BN26	KWZRZ5100AV26	WIRE ASS'Y
	3. KOP10964	TUNER PCB ASS'Y	BN32	KWZRZ5100AV32	WIRE ASS'Y
	4. KOP10965	SURROUND PCB ASS'Y	BN34	KWZRZ5100AV34	WIRE ASS'Y
	5. KOP10967	MAIN PCB ASS'Y	BN36	KWZRZ5100AV36	WIRE ASS'Y
	6. KOP11015	FUSE PCB ASS'Y	BN37	KWZRZ5100AV37	WIRE ASS'Y
FRONT PCB BLOCK CONSISTS FOLLOWING P.C.B.			BN42	KWZRZ5100AV42	WIRE ASS'Y
<ul style="list-style-type: none"> · u-COM P.C. BOARD · SP SWITCH P.C. BOARD · TONE CONTROL P.C. BOARD · MASTER VR P.C. BOARD · POWER SWITCH P.C. BOARD 			BN81	KWZRZ5100AV81	WIRE ASS'Y
INPUT PCB BLOCK CONSISTS FOLLOWING P.C.B.			BN91	KWZRZ5100AV91	WIRE ASS'Y
<ul style="list-style-type: none"> · INPUT & C/S AMP P.C. BOARD 			BN92	KWZRZ5100AV92	WIRE ASS'Y
TUNER PCB BLOCK CONSISTS FOLLOWING P.C.B.			BN93	KWZRZ5100AV93	WIRE ASS'Y
<ul style="list-style-type: none"> · TUNER AMP P.C. BOARD 			BN94	KWZRZ5100AV94	WIRE ASS'Y
SURROUND PCB BLOCK CONSISTS FOLLOWING P.C.B.			CN31	KJP03GA09ZG	WAFER
<ul style="list-style-type: none"> · SURROUND P.C. BOARD 			CN32	KJP07GA01ZM	WAFER
MAIN PCB BLOCK CONSISTS FOLLOWING P.C.B.			CN35	KJP03GA01ZM	WAFER
<ul style="list-style-type: none"> · POWER & L/R AMP P.C. BOARD · VIDEO CONTROL P.C. BOARD · POWER SUPPLY P.C. BOARD · C/S SPEAKER P.C. BOARD 			CN36	KJP04GA01ZM	WAFER
			CN37	KJP02GA01ZM	WAFER
			CN82	KJP04GA01ZM	WAFER
			CN87	KJP02KA060ZY	WAFER
			C901	BCES5R5V104	CAP , GOLD
			C902	KCEA0JH102B	CAP , ELECT
			C925	BCKWKC103MF	CAP , CERAMIC
			FIP1	KFLSVA15MM03	F.I.P.
			JB21	KJJ4M017Z	JACK , VCR
			JB22	KJJ4M018Z	JACK , VCR
			JB23	KJJ4M019Z	JACK , VCR
			JK71	BJJ2E019Z	JACK , HEADPHONE
			L901	KLQ02C100KT	COIL
			S901~S939	BST1A014ZT	SW , TACT
			SW71,SW72	KSH2B017Z	SW , PUSH
			SW81	KSH1A001ZV	SW , PUSH
			VR31,VR32	BVV2X01C104Z	RES , VARIABLE
			VR33	BVV1U01W104Z	RES , VARIABLE
			VR34	BVVBB01A104Z	RES , VARIABLE
			X901	KOX08000E160C	CRYSTAL
			Z901	KRGSN7X104J	RES , NETWORK
			Z902	KRGSN6X104J	RES , NETWORK
1. FRONT PCB			2. INPUT PCB		
IC31,IC32	BVINJM4558L	I.C , OP AMP	IC1	BVINJM4558L	I.C , OP AMP
IC35	KVIA6259S	I.C , OP AMP	IC2	BVINJU7313L	I.C , FUNC. SEL
IC91	BVIANAM1174M	I.C , u-COM	IC3	BVINJU7311L	I.C , FUNC. SEL
IC92	BRVPIC12043	I.C , SENSOR	IC4	BVINJM4558L	I.C , OP AMP
IC93	BVIRE5VA30CC	I.C , RESET	Q1,Q2	KVTKTC2878BT	T.R
Q341,Q342	KVTKSD1021YT	T.R	Q101,Q102	KVTKTC2878BT	T.R
Q343,Q344	KVTKSB811YT	T.R	Q103,Q104	KVTKTC2878BT	T.R
Q901	KVTKSB811YT	T.R	Q105,Q106	KVTKSA992FT	T.R
Q902	KVT2SC1740SRT	T.R			
Q904,Q905	KVTDTA114YST	T.R			
Q908	KVTDTA114YST	T.R			
Q909,Q910	KVTDTC114YST	T.R			
D301	KVDDL22VR	L.E.D , RED			
D901,D902	KVD1N4148MT	DIODE			
D904	KVD1N4148MT	DIODE			
D906	KVD1N4148T	DIODE			
D907	KVD1N4148MT	DIODE			

REF.No.	PART No.	DESCRIPTION	REF.No.	PART No.	DESCRIPTION
Q109,Q110	BVT2SD1585L	T.R	Q511,Q512	KVTDTA114YST	T.R
Q111,Q112	KVTKSC2785YT	T.R	Q514	KVTDTC114TST	T.R
Q113,Q114	KVTKSC2785YT	T.R	Q519,Q520	KVT2SC1740SRT	T.R
Q115,Q116	KVTKSC2316YT	T.R	D501	KVDKV1236Z	DIODE , VARICAP
Q117,Q118	KVTKSA916YT	T.R	D502~D509	KVD1N4148MT	DIODE
Q119,Q120	KVTKTD9980	T.R	D601	KVD1N4148MT	DIODE
Q121,Q122	KVTKSD7780	T.R	BPF1	BRVBPM88	B.P.F
Q123,Q124	KVTKSC2785YT	T.R	CB51	KJP13HB53ZG	WAFER , HOUSING (UL/SS)
Q125	KVTDTA114YST	T.R	CB51	KJP16HB53ZG	WAFER , HOUSING (CE)
Q126,Q127	KVTKSC2785YT	T.R	CF51,CF52	BVFE107MSH-A	FILTER , CERAMIC
Q128	KVTKSA733CYT	T.R	CF53	BVFSFZ450F	FILTER , CERAMIC
Q130	KVTKSC2785YT	T.R	CT51	KCRA020S12	CAP , VARIABLE
Q131,Q132	KVTDTC114TST	T.R	FE51	KNVFTA3508H	PACK , TUNER
D101	KVDMTZ15BT	DIODE , ZENER	FE51	KNVFTA4460H	PACK , TUNER
D102	KVDUZ15BMT	DIODE , ZENER	JK51	KJJ3S006Z	TERMINAL , ANT
D103,D104	KVD1N4148MT	DIODE	JK51	KJJ3S007Z	TERMINAL , ANT
D106~D108	KVD1N4148MT	DIODE	JW51	KWE820270AA	WIRE ASS'Y
BN21	KWZRZ5100AV21	WIRE ASS'Y	JW52	KWZNT20001	WIRE ASS'Y
BN27	KWZRZ5100AV27	WIRE ASS'Y	L501	KLA2C005	COIL , AM ANT2
BN31	KWZRZ5100AV31	WIRE ASS'Y	L502	KLO2B008Z	COIL , AM OSC
BN35	KWZRZ5100AV35	WIRE ASS'Y	L505,L506	KLQB542KLZ	COIL
BN71	KWZRZ5100AV71	WIRE ASS'Y	L651	KLA4Y106Z	COIL , FILTER
CN25	KJP05GA09ZG	WAFER	L652	KLQA183KW	COIL
CN41	KJP03GA63ZY	WAFER	T501	KLI3B020-G	I.F.T , FM
CN43	KJP10GA63ZY	WAFER	T502	KLI3B021-G	I.F.T , FM
CN51	KJP13GA52ZG	WAFER (UL/SS)	T503	KLI2B105-G	I.F.T , FM
CN51	KJP16GA52ZG	WAFER (CE)	VR51,VR52	BVN1PA203B01T	RES , SEMI FIXED
CN72	KJP10GA01ZM	WAFER	VR53,VR54	BVN1PA103B01T	RES , SEMI FIXED
CN91	KJP08GA01ZM	WAFER	VR62	BVN1PA502B01T	RES , SEMI FIXED
CN92	KJP05GA01ZM	WAFER	X501	BVFBFU450C4N	FILTER , CERAMIC
L101,102	KLEYK1R8KA	COIL	X502	KOX07200A200C	CRYSTAL
R137,R138	KRG1ANJ181H	RES , METAL OXIDE FILM	X601	BVFC5B456F33	RESONATOR , CERAMIC
R143~R146	KRF3CJR27H	RES , CEMENT			
R151,R152	KRG1ANJ4R7H	RES , METAL OXIDE FILM			
R155,R156	KRG1ANJ100H	RES , METAL OXIDE FILM			
	KJJ4P014Z	JACK , IN/OUT			
	KJJ4R012Z	TERMINAL , IN/OUT			
3. TUNER P.C.B			4. SURROUND P.C.B		
IC51	BVILA1266	I.C , FM IF & AM RF,IF	IC42	BVINJW1102L	I.C , PRO LOGIC
IC52	BVILA3361	I.C , MPX	IC43	BVINJU9702D	I.C , DELAY
IC53	BVILM7001	I.C , PLL	CB41	KJP03HB60ZY	HOUSING
IC54	KVIMC4558S	I.C , OP AMP	CB43	KJP10HB60ZY	HOUSING
IC62	BVILA2232	I.C , RDS	X401	BVFKBR-1000H	RESONATOR , CERAMIC
Q501,Q502	KVTKTC31920T	T.R			
Q503	KVTDTA114YST	T.R			
Q506,Q507	KVT2SC1740SRT	T.R			
			5. MAIN P.C.B		
			IC27	KVIGD4066B	I.C , SWITCHING
			IC81	KVIMC7812C	I.C , REGULATOR
			IC82	KVIMC7912C	I.C , REGULATOR
			IC83,IC84	KVIMC7805C	I.C , REGULATOR
			Q261~Q266	KVTKSA733CYT	T.R
			Q701~Q704	KVTKSA992FT	T.R

REF.No.	PART No.	DESCRIPTION	REF.No.	PART No.	DESCRIPTION
Q705~Q708	KVTKSC2785YT	T.R	C801,C802	KCETS63V822U	CAP , ELECT
Q709,Q710	BVT2SD1585L	T.R	C803,C804	KCEA1EH471E	CAP , ELECT
Q711,Q712	KVTKSC2690A	T.R	C825	KCEA0JH102B	CAP , ELECT
Q713,Q714	KVTKSA1220A	T.R	C830	KCEA1EH102E	CAP , ELECT
Q715,Q716	BVT2SC4467	T.R	JW85	KWED202100PP	WIRE
Q717,Q718	BVT2SA1694	T.R	JW87	KWZRZ5100AV87	WIRE ASS'Y
Q719~Q722	KVTKTC2878BT	T.R	L701,L702	KLEYK1R8KA	COIL
Q723,Q724	KVTKSC2785YT	T.R	RY81	KSL1A007ZE	RELAY
Q725	KVTKSA1175YT	T.R	RY82	KSL4B003ZW	RELAY
Q726~Q729	KVTKSC2785YT	T.R	R283~R285	KRG1ANJ151H	RES,METAL OXIDE FILM
Q730	KVTKSR2206T	T.R	R286	KRG1ANJ100H	RES,METAL OXIDE FILM
Q801	KVTKTD288Y	T.R	R733,R734	KRG1ANJ181H	RES,METAL OXIDE FILM
Q802	KVTKSA1175YT	T.R	R735~R738	KRF3CJR27H	RES , CEMENT
Q803	KVTKSC2785YT	T.R	R745,R746	KRG1ANJ4R7H	RES,METAL OXIDE FILM
Q804	KVTKSA614Y	T.R	R747,R748	KRG1ANJ100H	RES,METAL OXIDE FILM
Q805	KVTKSC2785YT	T.R	R801,R802	KRD50FJ123T	RES , CARBON
Q806	KVTKSA1175YT	T.R	R805,R806	KRQ1CJR47	RES , FUSE
Q807	KVTKSA614Y	T.R	R807,R808	KRG1ANJ4R7H	RES,METAL OXIDE FILM
Q808	KVTKSC2785YT	T.R	R832	KRD50TJ335T	RES , CARBON
Q809	KVTKTA1271YT	T.R	R833	KRQ1CJ100	RES , FUSE
Q810,Q811	KVTKTC3203YT	T.R	R834	KRG1ANJ100H	RES,METAL OXIDE FILM
Q812	KVTDTA114YST	T.R		BJJ2D003Z	JACK , STEREO
Q813	KVTKSC945CYT	T.R		KJJ4N012Z	JACK , BOARD
Q814	KVTKSA733CYT	T.R		KJJ4S005Z	JACK , VCR
D8,D9	KVDIN4148MT	DIODE		KJJ5Q001Z-C	TERMINAL,SPEAKER 8P
D701,D702	KVDUZ15BMT	DIODE , ZENER		KJJ5R004Z	TERMINAL , SPEAKER
D705~D707	KVDIN4148T	DIODE		KLT5J022ZE	TRANS , SUB (CE)
D708~D710	KVDIN4148MT	DIODE		KLT5J022ZW	TRANS , SUB (SS)
D801	BVDPBPC803F	DIODE , BRIDGE		KLT5J022ZU	TRANS , SUB (UL)
D811~D813	KVD1N4003ST	DIODE , RECT			
D814	KVDUZ6.2BMT	DIODE , ZENER		6. FUSE P.C.B	
D815	KVDUZ33BMT	DIODE , ZENER	Q811	KVTKTC3203YT	T.R
D816~D818	KVD1N4148MT	DIODE	D817	KVD1N4148MT	DIODE
D819~D822	KVD1N4003ST	DIODE , RECT	CN86	KJP04GA01ZM	WAFER
D823	KVD1N4148MT	DIODE	CN88	KJP03KA060ZY	WAFER
BN72	KWZRZ5100AV72	WIRE ASS'Y	JW11	KWEP215110VV	WIRE
BN82	KWZRZ5100AV82	WIRE ASS'Y	JW12	KWEP212120VV	WIRE
BN83	KWZRZ5100AV83	WIRE ASS'Y	JW13	KWEP202110VV	WIRE
BN84	KWZRZ5100AV84	WIRE ASS'Y	JW87	KWZRZ5100AV87	WIRE ASS'Y
CN21	KJP04GA01ZM	WIRE ASS'Y	RY81	KSL1A007ZE	RELAY
CN24	KJP03GA09ZG	WAFER	SW81	KSS2B003Y	SW , SLIDE
CN26	KJP03GA01ZM	WAFER		7. MISCELLANEOUS	
CN27	KJP02GA01ZM	WAFER		KSA1A008Z	AM LOOP ANT ASS'Y (CE)
CN34	KJP03GA01ZM	WAFER		KSA1A009Z	ANT , AM LOOP(UL/SS)
CN71	KJP05GA09ZG	WAFER		KSA1A010Z	ANT , FM T (UL/SS)
CN81	KJP04GA01ZM	WAFER		KLT5U005ZE	TRANS , MAIN (CE)
CN83	KJP05GB03ZM	WAFER		KLT5U005ZU	TRANS , MAIN (UL)
CN84	KJP06GB03ZM	WAFER		KLT5U005ZW	TRANS , MAIN (SS)
CN88	KJP02KA060ZY	WAFER		KBA2C3150NRE	FUSE (CE)
CN93	KJP05GA09ZG	WAFER		KBA2C3150NRU	FUSE (SS)
CN94	KJP05GA01ZM	WAFER		KBA2C6000NRU	FUSE (UL/SS)

山水電気株式會社

〒962-04 福島県須賀川市大字滑川字関の上 22 番地

22, AZA SEKINOUE, OAZA NAMEGAWA, SUKAGAWA-SHI, FUKUSHIMA-KEN 962-04, JAPAN