

SANSUI

RZ-5900 RZ-3900

STEREO RECEIVER

SERVICE MANUAL

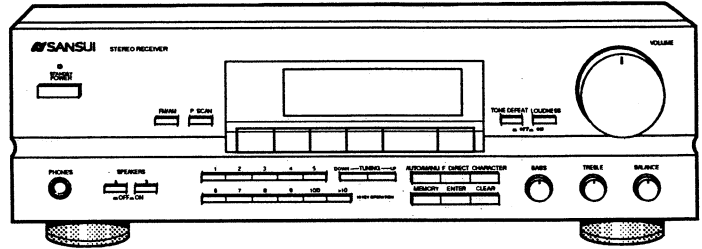

CAUTION

1. Parts identified the \triangle symbol on the schematic diagram and the parts list are critical for safety. Use only replacement parts that have critical characteristics recommended by the manufacturer.
2. Make leakage-current for resistance measurements to determine that exposed parts are acceptably insulated from the supply circuit before returning the appliance to the customer.

Notice

- The symbols, UL, CSA, SS, EU, UK, IPT, GE, and XX on the Parts list and the schematic diagram mean followings respectively.

UL Manufactured for U.S.A market.
(Underwriters Laboratories approved model.)
CSA Manufactured for Canadian market.
SS Manufactured for Saudi Arabian market.
EU Manufactured for European market.
UK Manufactured for United Kingdom market.
IPT Manufactured for Italy market.
GE Manufactured for F.R. Germany market.
XX(EXPORT) Standard Version.
NON MARK Common Parts.

- Design and specifications subject to changes without notice for improvements.
- Due to local laws and regulations, this unit sold in some areas are not equipped with variable voltage selectors.

Notice for Parts

1. Some printed circuit board are not supplied assembled. To separate these in this Service Manual, the stock numbers are not indicated for these boards. However, stock numbers for individual parts are indicated.
2. Since some capacitors and resistors are omitted from parts lists in service manual, refer to the Common Parts List for capacitors and resistors, which was issued on June 1987.
3. Abbreviations in this Parts List are as follows.

Abbreviations List

C.R.	:Carbon Resistor	E.B.L.	:Low Leak Bi-Polar Electrolytic Capacitor
S.R.	:Solid Resistor	Ta.C.	:Tantalum Capacitor
Ce.R.	:Cement Resistor	F.C.	:Film Capacitor
M.R.	:Metal Film Resistor	M.P.	:Metalized Paper Capacitor
F.R.	:Fusing Resistor	P.C.	:Polystyrene Capacitor
N.I.R.	:Non-Inflammable Resistor	M.M.C.	:Metalized Mylar Capacitor
A.R.	:Array Resistor	A.C.	:Array Capacitor
C.C.	:Ceramic Capacitor	V.R.	:Variable Resistor
C.T.	:Ceramic Capacitor, Temperature Compensation	S.V.R.	:Semi Variable Resistor
E.C.	:Electrolytic Capacitor	SW.	:Switch
E.L.	:Low Leak Electrolytic Capacitor	Chip.R.	:Chip Resistor
E.B.	:Bi-Polar Electrolytic Capacitor	Chip.C.	:Chip Capacitor

1. BLOCK DIAGRAM

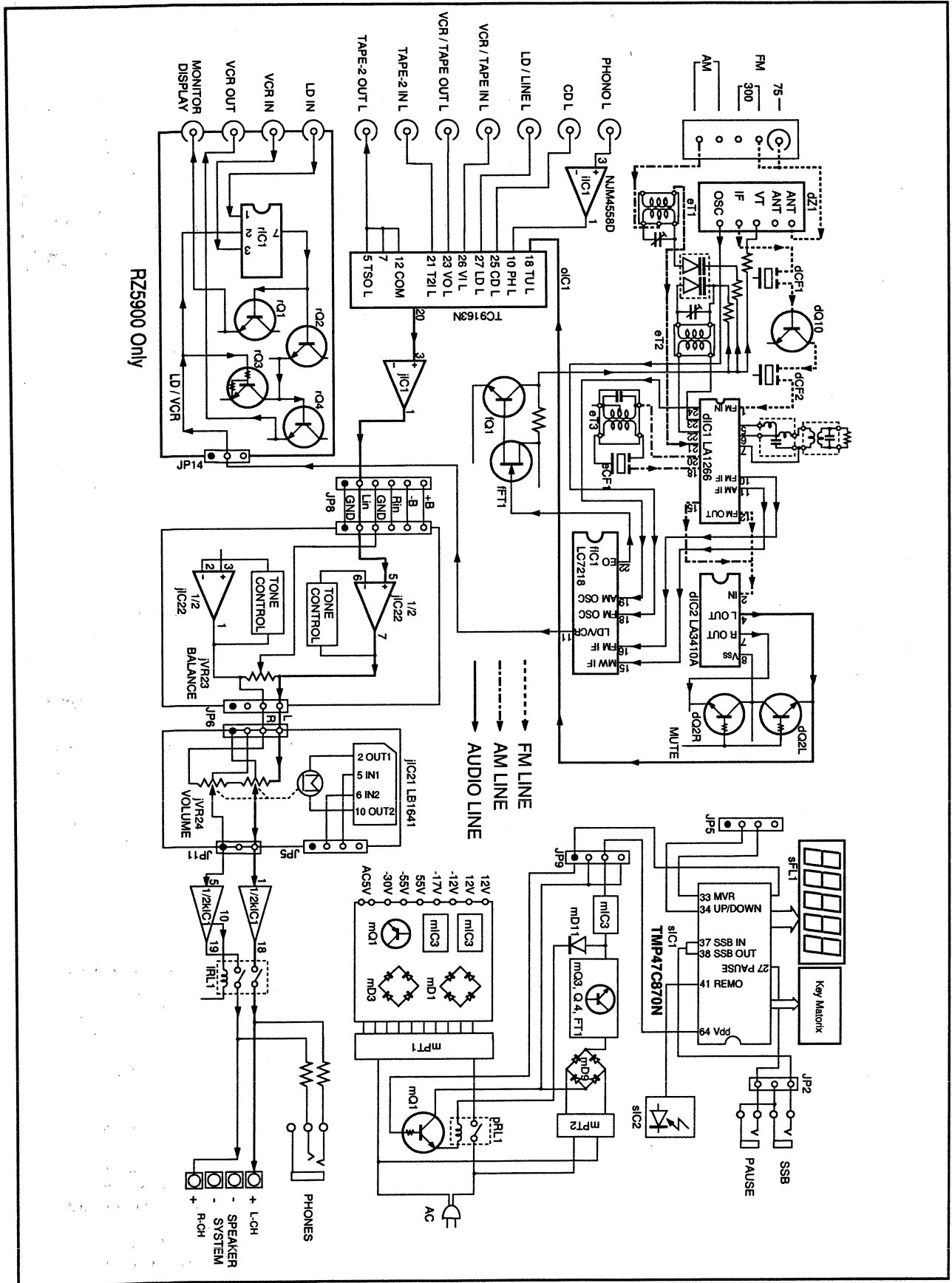

2. SCHEMATIC DIAGRAM 2-1. RZ-5900

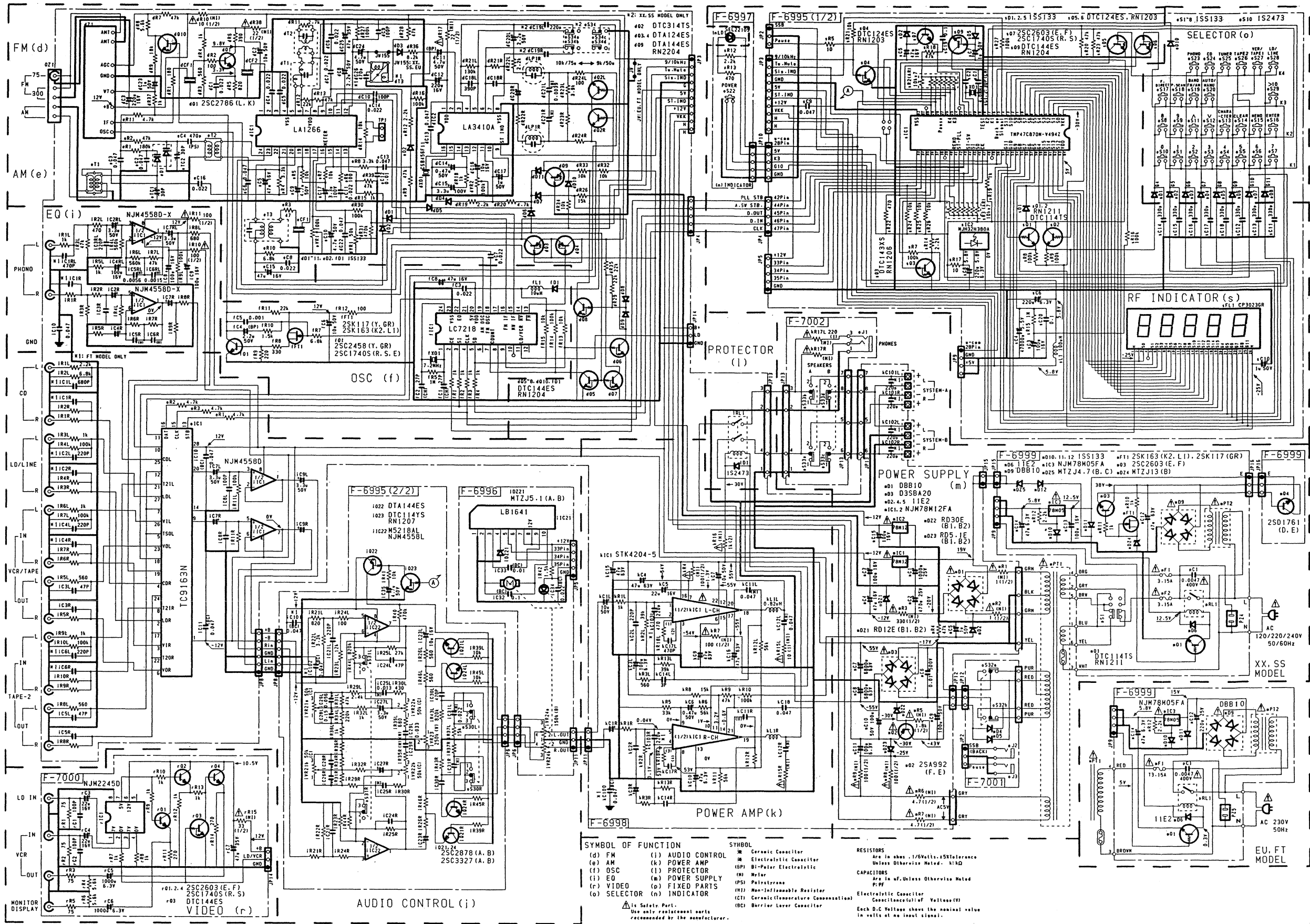

2-2. RZ-3900

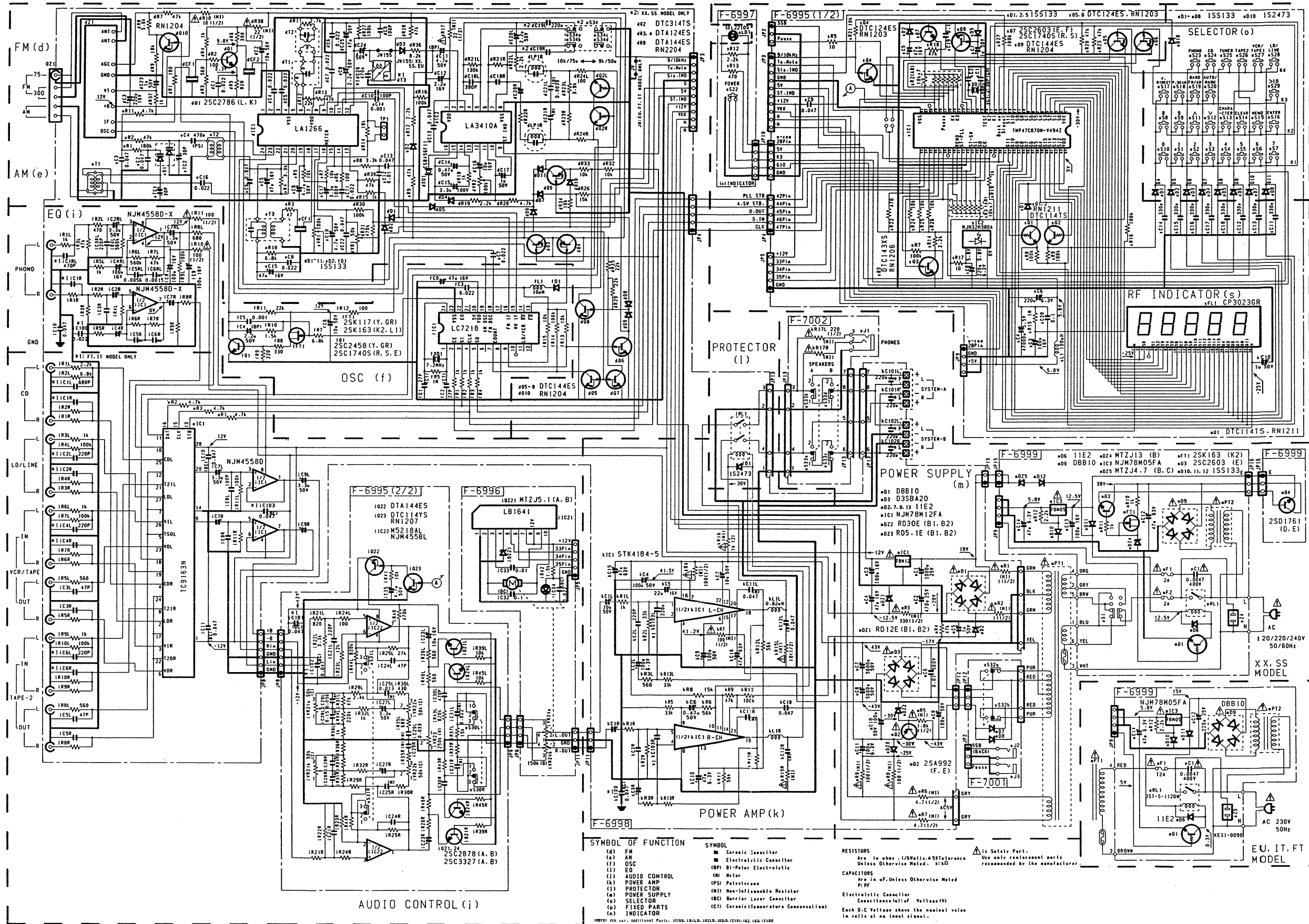

3. ADJUSTMENT

(1) FM IF ADJUSTMENT

Note : 1. SELECTOR FM 2. AUTO/MANU. MANU.

STEP	SUBJECT	FEED SIGNAL		MEASURE OUTPUT	ADJUST	ADJUST FOR DC 0V ±30mV	REMARKS
		FROM	TO				
1	Discriminator Coil Adj.	1	98MHz ANT Input, 65dBf(59.8dB), 1kHz (100% MOD.), FM SSG.	FM ANT Terminal	Across the ITP1, DC Volt Meter.	dT1 (F-6998)	• Repeat procedures as stated in subject 1 & 2.
		2	Same as above	Same as above	REC OUT L or R-CH Tuned Indicator	dT1 (F-6998)	

(2) FM STEREO ADJUSTMENT

Note : 1. SELECTOR FM 2. AUTO/MANU. AUTO

STEP	SUBJECT	FEED SIGNAL		MEASURE OUTPUT	ADJUST	ADJUST FOR	REMARKS
		FROM	TO				
1	Separation Adj.	98MHz ANT Input, 65dBf(59.8dB),FM SSG Pilot(9% MOD.), L MODE 1kHz + Pilot (100% MOD.), STEREO SG.	FM ANT Terminal	REC OUT L-CH AC Volt Meter & Scope	—	—	• Confirm R → L-CH
				REC OUT R-CH AC Volt Meter & Scope	dVR2 (F-6998)	Max. Separation	
2	Muting Level Adj.	98MHz ANT Input, 25dBf(14.8dB),FM SSG Pilot(9% MOD.), L MODE 1kHz + Pilot (100% MOD.), STEREO SG.	FM ANT Terminal	Stereo indicator OUTPUT L-CH or R-CH, AC Volt Meter & Scope	dVR1 (F-6998)	Set to 24 dBf and the output to fade away	

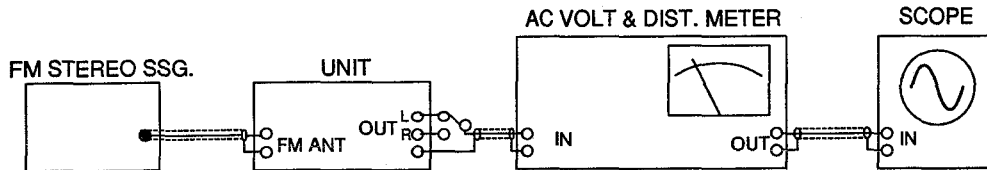

• F-6998 Adjustment Points

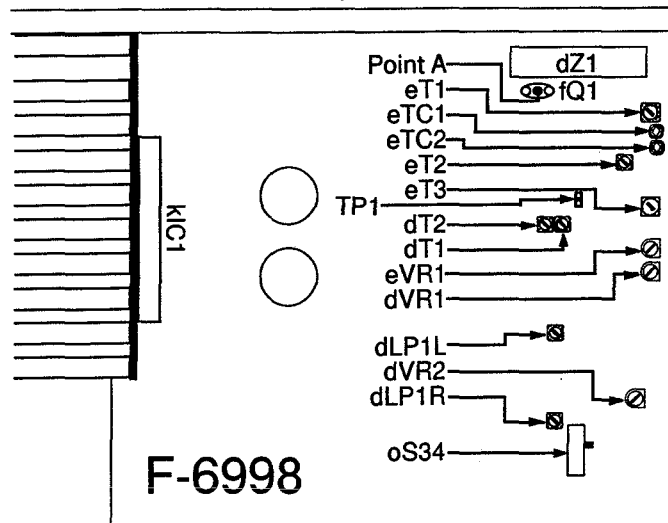

(3) AM ADJUSTMENT

Note : 1. SELECTORAM 2. AUTO/MANU.AUTO

STEP	SUBJECT	FEED SIGNAL		MEASURE OUTPUT	ADJUST	ADJUST FOR	REMARKS
		FROM	TO				
1.	IF Coil Adj.	1400kHz (or 1404kHz) ANT Input 55dB/m 400Hz (30% MOD.), AM SSG	ANT Terminal	REC OUT L or R-CH AC Volt Meter & Scope	eT3 (F-6998)	Max. Waveform	
2.	530kHz (or 531kHz) Tunning Adj.	No Input		Between Point A (col- lector of IQ1) & GND, DC Volt Meter	eT2 (F-6998)	DC 1.0V ±0.1V	• Repeat procedures as stared in subject 2 & 3
3.	1710kHz (or 1602kHz)	No Input		Same as above	eTC2 (F-6998)	DC 9.0V ±0.1V (or DC 8.0V ±0.1V)	
4.	600kHz (or 603kHz) RF Adj.	600kHz (or 603kHz) ANT Input 30dB/m 400Hz (30% MOD.), AM SSG	ANT Terminal	REC OUT L or R-CH AC Volt Meter & Scope	eT1 (F-6998)	Max. Output	• Repeat procedures as stared in subject 4 & 5
5.	1400kHz (or 1404kHz) RF Adj.	1400kHz (or 1404kHz) ANT Input 30dB/m 400Hz (30% MOD.), AM SSG	ANT Terminal	REC OUT L or R-CH AC Volt Meter & Scope	eTC1 (F-6998)	Max. Output	
6.	Signal Indica- tor Level Adj.	1000kHz (or 999kHz) ANT Input 70dB/m 400Hz (30% MOD.), AM SSG	ANT Terminal	Signal Indicator of FL Display	eVR1 (F-6998)	Make all signal Indi- cators lighting up.	

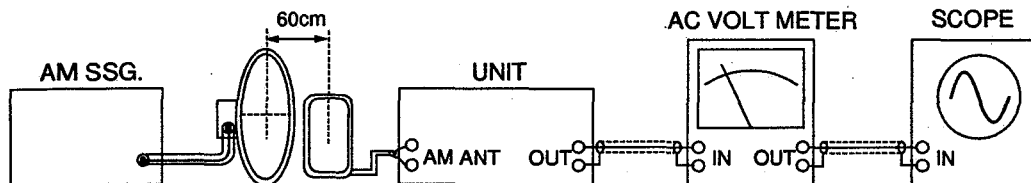

4. INTERIOR BLOCK DIAGRAM & TERMINAL FUNCTION OF ICs

LA1266 <AM/FM IF AMP>

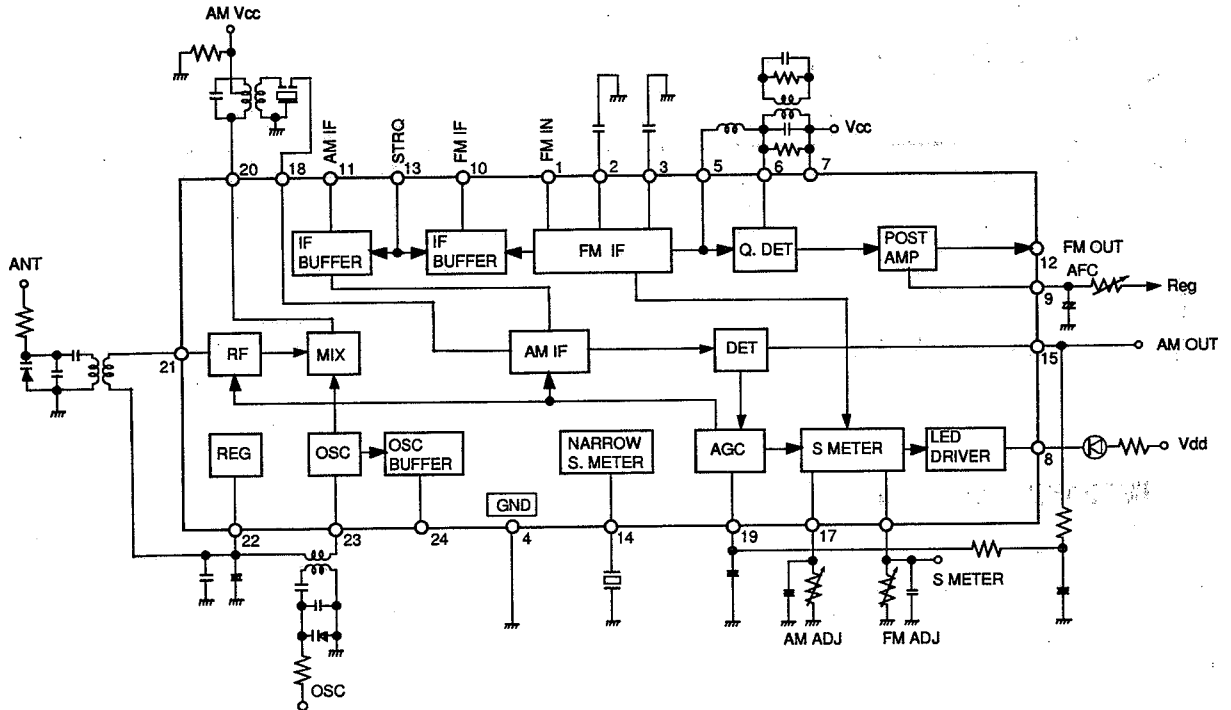

LA3410A <PLL FM MPX DEMODULATOR>

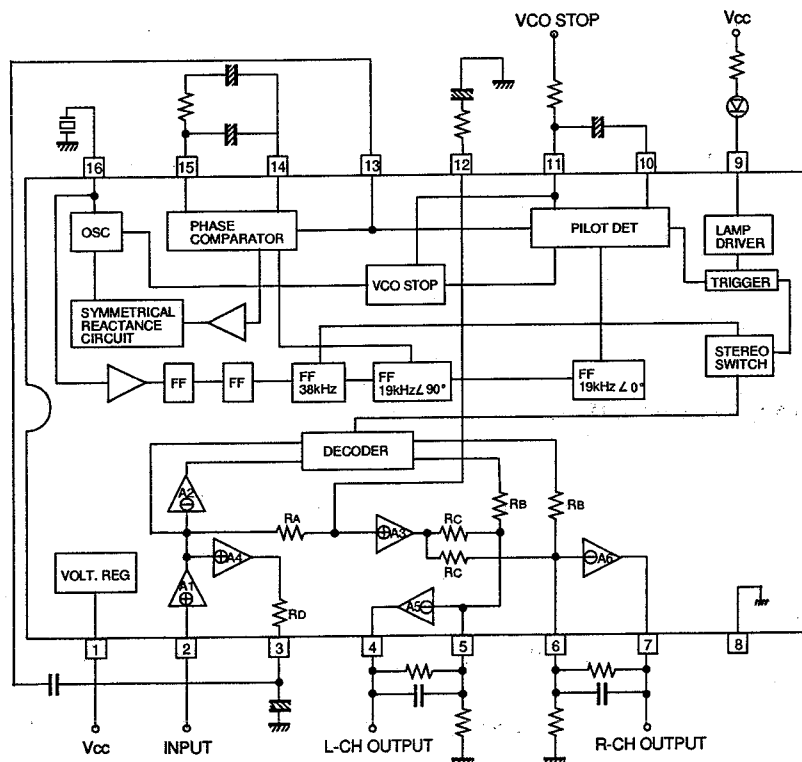

LC7218 <PLL SYNTHESIZER>

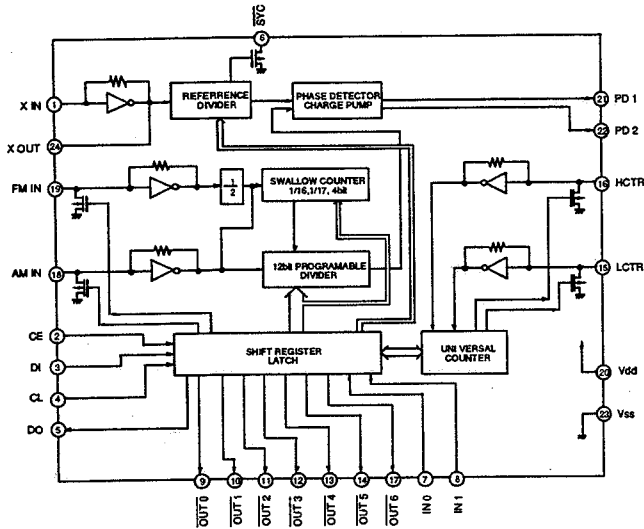

TC9163N <ANALOG SWITCH>

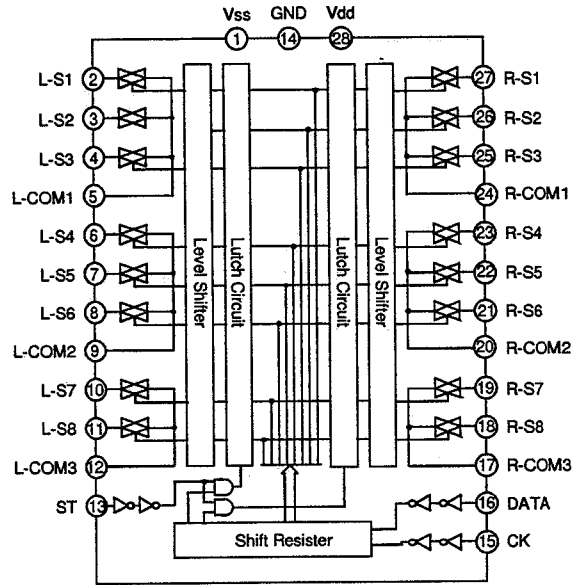

NJM2245D <ANALOG SWITCH>

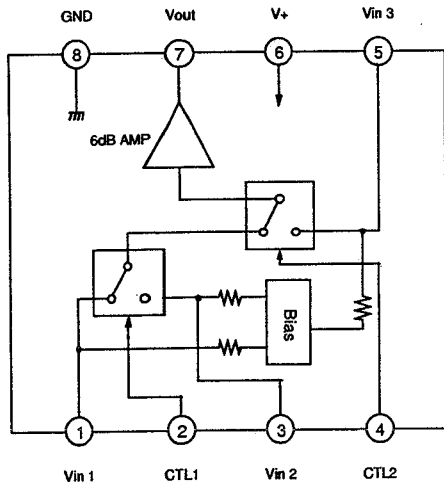

CTL1	CTL2	Vout
L	L	Vin 1
H	L	Vin 2
L/H	H	Vin 3

M5218AL/NJM4558AL <OP AMP>

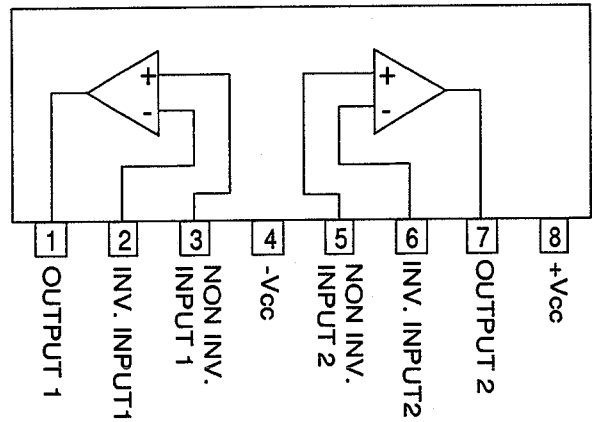

NJM4558D <OP AMP>

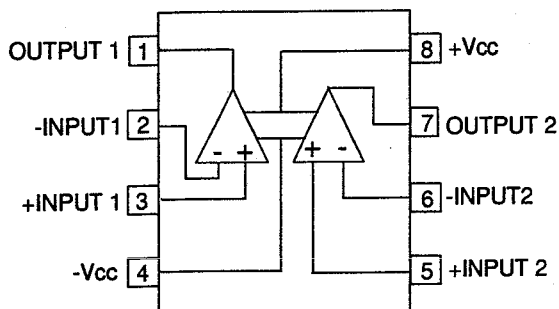

LB1641 <MOTOR DRIVER>

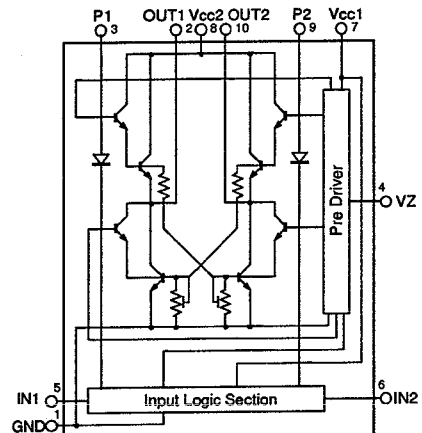

STK4204-5 <POWER AMP>

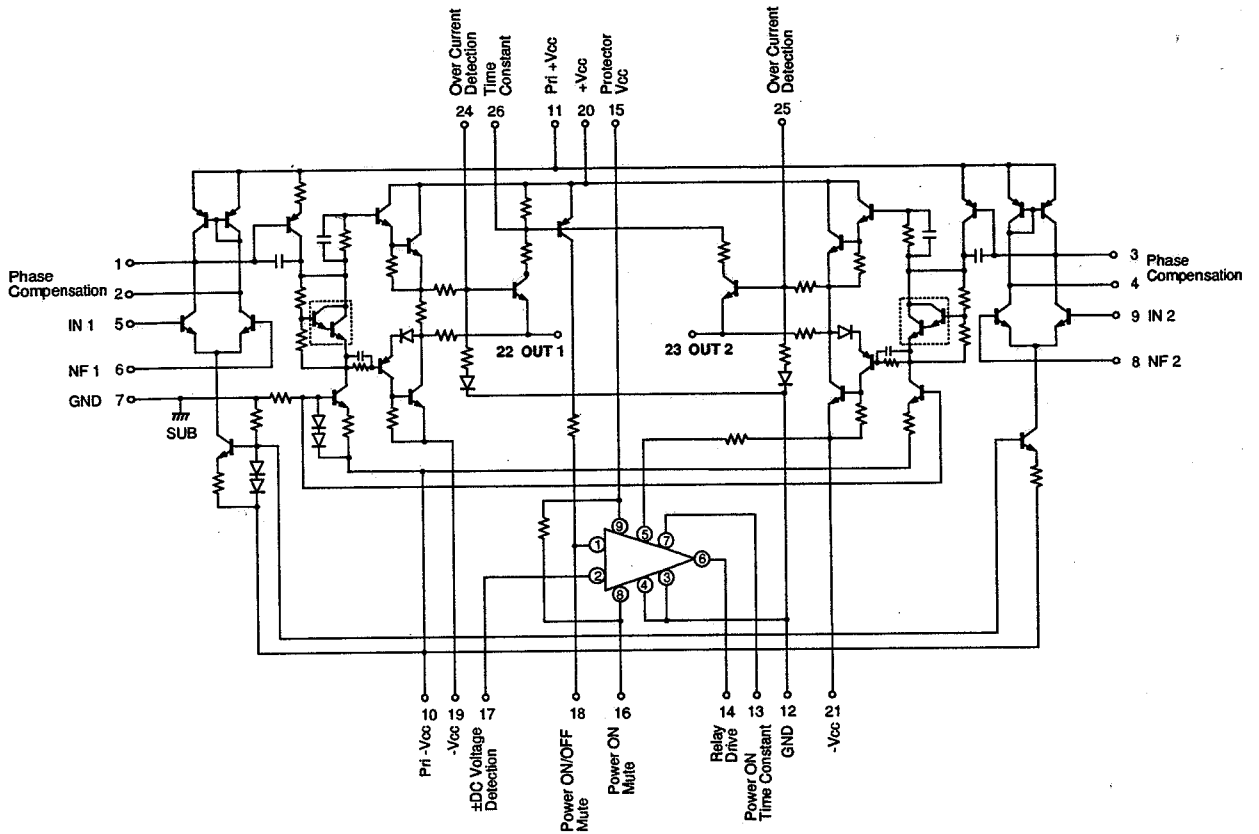

STK4184-5 <POWER AMP>

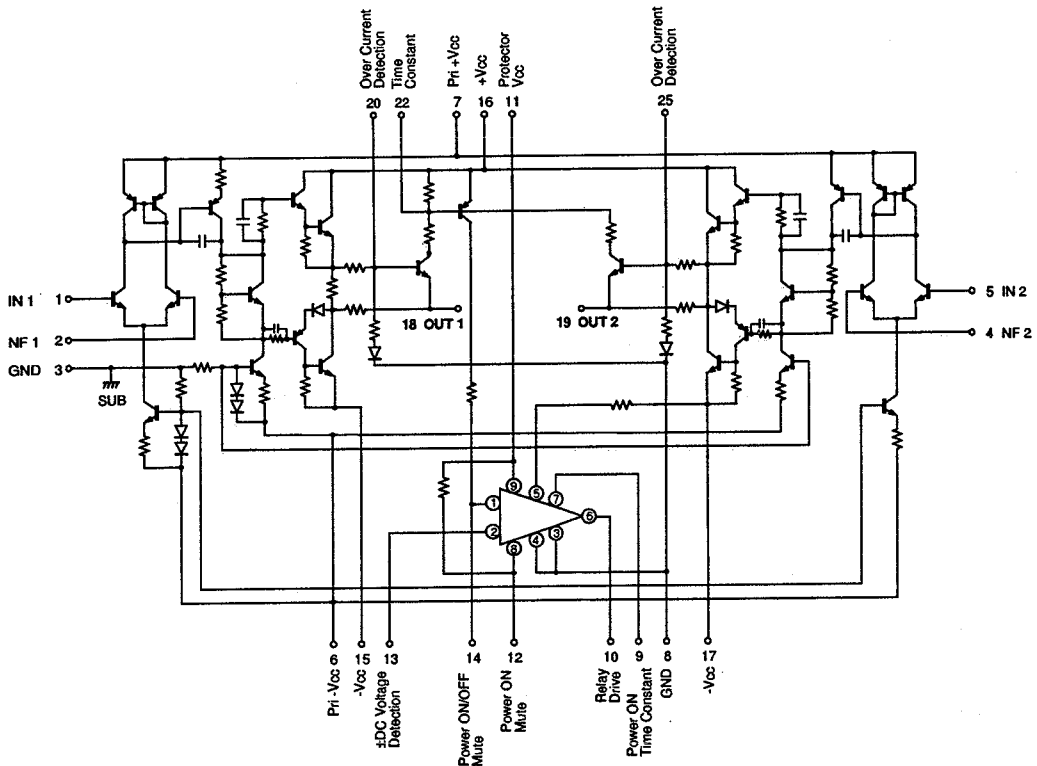

TMP47C870N-V494Z <SYSTEM CONTROLLER>

Pin No.	Pin Name	I/O	Description
2 – 13 60 – 63	S0 – S11 S15 – S12	O	Terminals for outputting segment signals to FL display.
52 – 59	G11 – G4	O	Terminals for outputting grid signals to FL display and key matrix return timing signals.
14	METER	I	Terminal for inputting analog signal for Signal Indicator of FL display.
15	BACK UP	I	Terminal to input back-up voltage.
16, 17 24, 25	K1, K2 $\overline{K3}, \overline{K4}$	I	Terminal for inputting a key return signal from externally connected key matrix.
22	BACK UP IN	I	Terminal to input back-up signal. "L" = BACK UP, "H" = RUN
27	PAUSE	O	Terminal to output signal for PAUSE.
28	POWER	O	Terminal to output a signal for power ON/OFF. This terminal changes to HIGH level in POWER ON mode and to LOW level in POWER OFF (STANDBY) mode.
29	MUTE	O	Terminal to output muting signal. These terminals are kept in "L" level in ordinary state, and in "H" level in muting. The muting signal is outputted in the following modes.
33	VR UP	O	Terminal to output a signal for volume UP. This terminal outputs a LOW level signal during volume up operation.
34	VR DOWN	O	Terminal to output a signal for volume DOWN. This terminal outputs a LOW level signal during volume down operation.
35	VR LED	O	Terminal to output a signal for volume LED. This terminal outputs pulses during volume up/down operation.
36	MUTE	O	Terminal to output muting signal. these terminals are kept in "L" level in ordinary state, and in "H" level muting. The muting signal is outputted in the following modes.
37	SSB IN	I	Terminal to input serial buss data.
38	SSB OUT	O	Terminal to output serial data.
41	REMOTE	I	Terminal to input a signal from the remote controller.
42	STB-PLL	O	Terminal to output a signal for chip selector.
44	STB-SW	O	Serial interfaces for STB (Strobe Pulse Output)
45 46 47	SI SO CK	I O O	Serial interfaces for SI (Serial data input), SO (Serial data output), and CK (Serial clock output).
48	ST. IND	I	Terminal to input a signal for FM STEREO indicator of FL display. When this terminal is LOW, STEREO indicator of FL display is lighted.

5. PARTS LOCATION ON BOARD

F-6995. CONTROL BOARD

COMPONENT SIDE

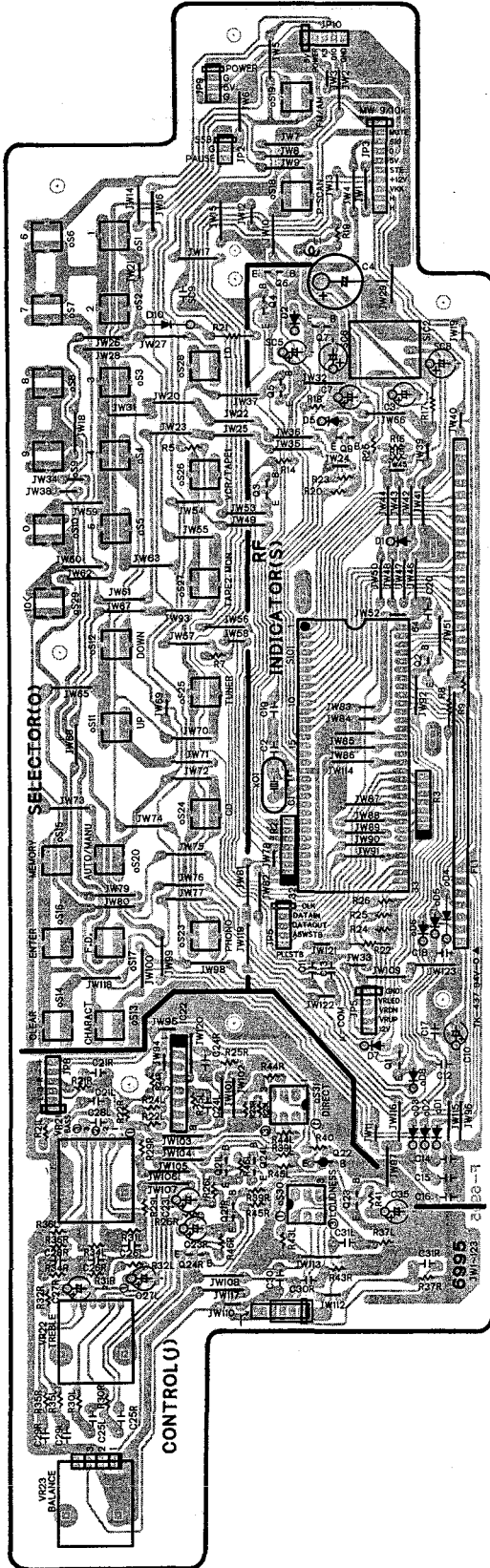

F-6999. POWER SUPPLY BOARD

COMPONENT SIDE

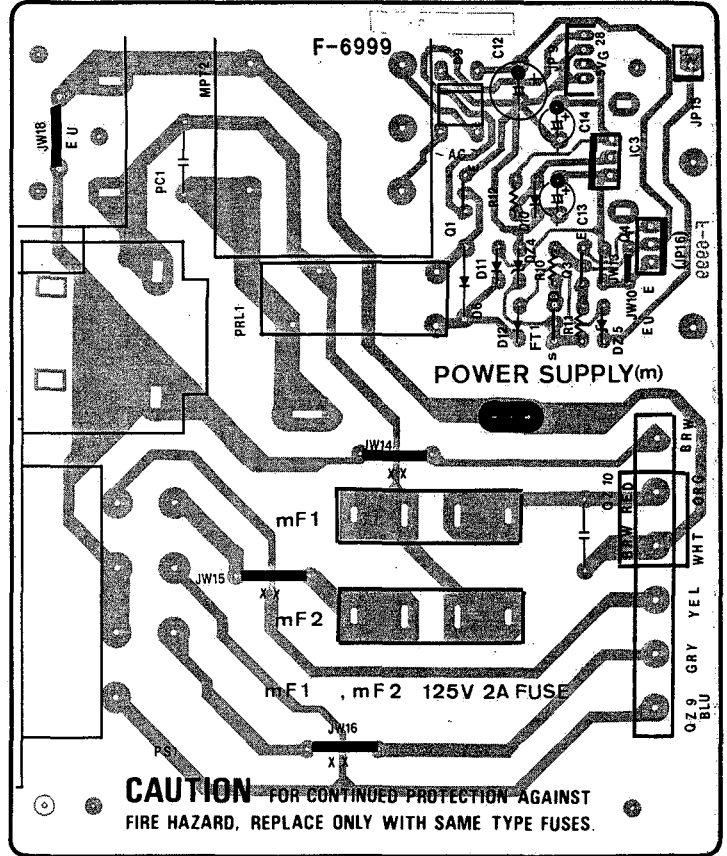

F-7000. VIDEO BOARD

COMPONENT SIDE

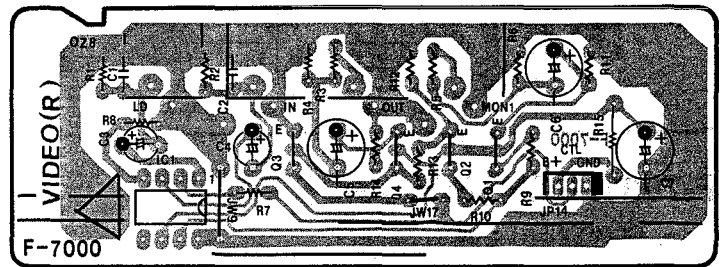

F-7002. SP SW. BOARD

COMPONENT SIDE

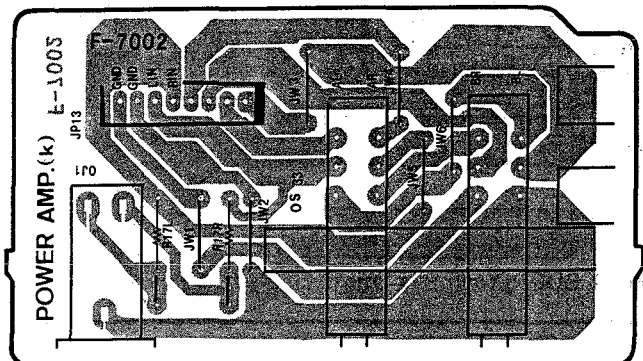

F-6998 MAIN BOARD

COMPONENT SIDE

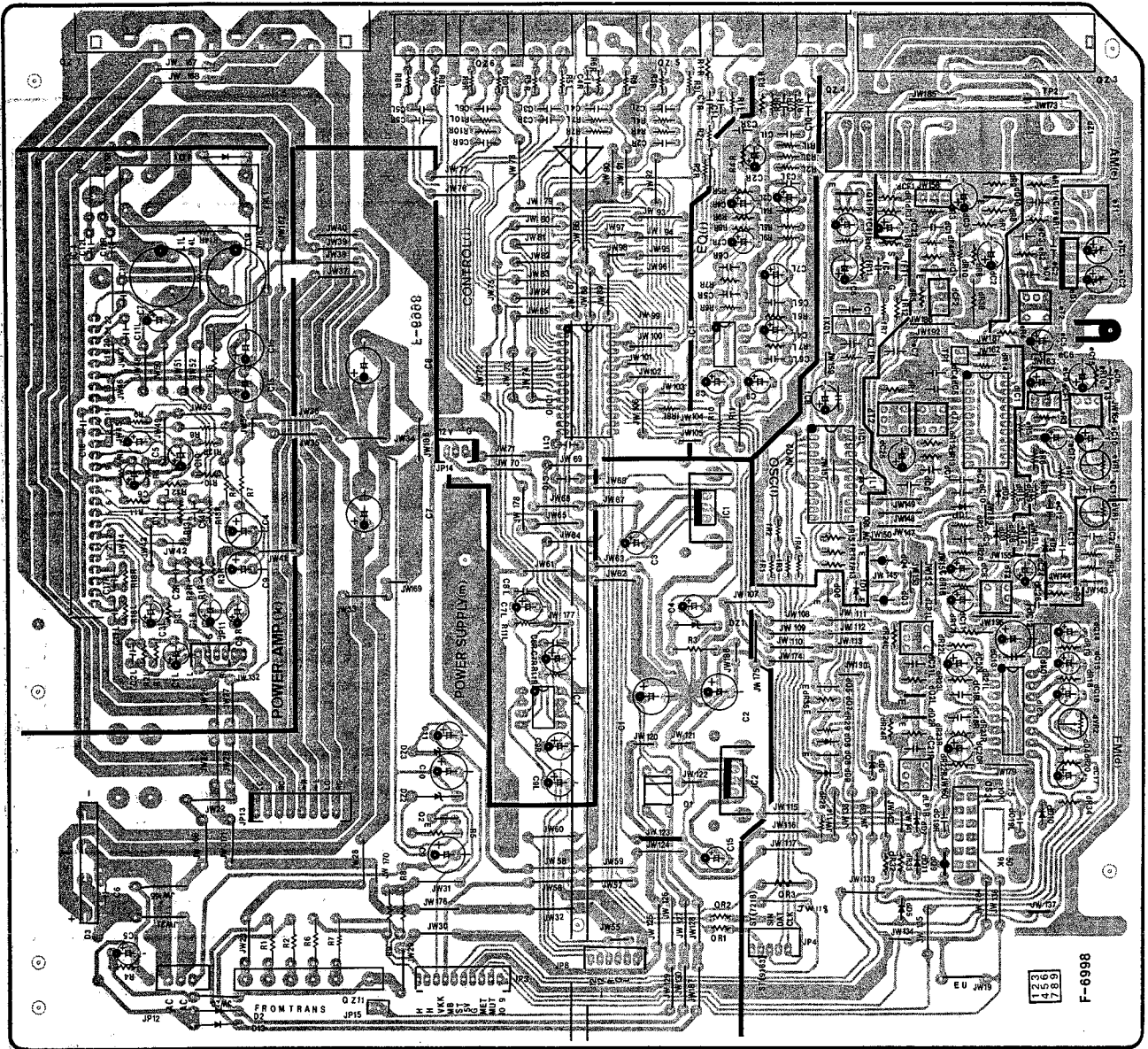

F-7001. CONTROL JACK BOARD

COMPONENT SIDE

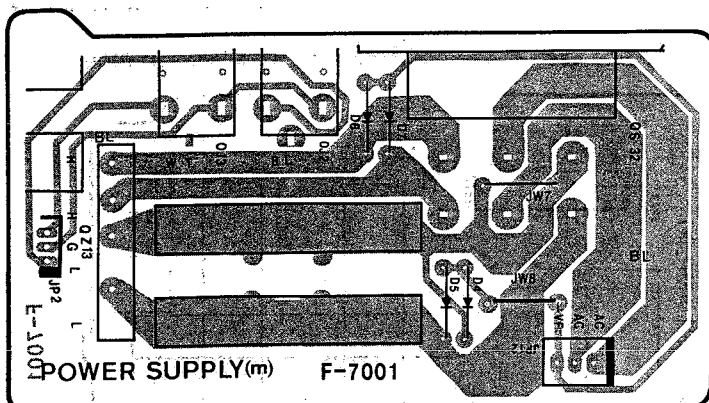

F-6996. VOLUME BOARD

COMPONENT SIDE

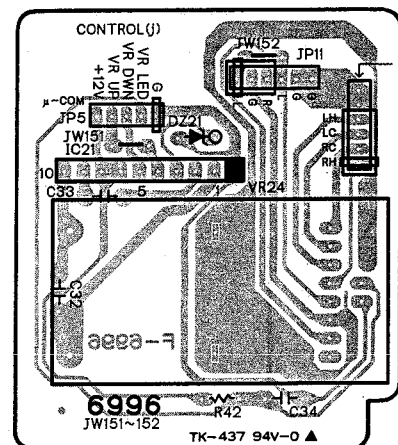

6. PARTS LIST OF BOARD

F-6995. CONTROL BOARD

<Stock No. 01369501> (RZ-5900)

<Stock No. 01370501> (RZ-3900)

Parts No.	Stock No.	Description
• TRANSISTOR		
jQ22	46834200	DTA144ES
jQ23	48171600	DTC114YS
	or 49388600	RN1207
jQ24	46604301	2SC3327
• IC		
jIC22	49439500	NJM4558L OPAMP
	or 49541200	M5218AL OPAMP
jVR21	83364200	V.R., BASS
jVR22	83364200	V.R., TREBLE
jVR23	83364100	V.R., BALANCE
• DIODE		
oD1 to 8	46464100	1SS133
oD10	03117600	1S2473
oS1 to 20	49326300	PUSH SW. SKHVBF 5H160G
oS23 to 29	49326300	PUSH SW. SKHVBF 5H160G
oS30	46563500	PUSH SW.
oS31	46563500	PUSH SW.
sIC2	49913300	REMOTE RECEIVER UNIT
• TRANSISTOR		
sQ1	48223100	DTC114TS
	or 49389000	RN1211
sQ2	48223100	DTC114TS
	or 49389000	RN1211
sQ3	48230800	DTC143XS
	or 49388500	RN1206
sQ4	46367101	2SC2603
	or 48058801	2SC1740S
sQ5	46719900	DTC124ES
	or 49388200	RN1203
sQ6	46719900	DTC124ES
	or 49388200	RN1203
sQ7	46367101	2SC2603
	or 48058801	2SC1740S
sQ9	46834300	DTC144ES
	or 49388300	RN1204

Parts No.	Stock No.	Description
• IC		
sIC1	49918200	TMP47C870N-V494Z
sXO1	48241600	CERAMIC OSC ELEMENT KBR-4.0MS
• DIODE		
sD1	46464100	1SS133
sD2	46464100	1SS133
sD5	46464100	1SS133
sFL1	49317100	FL. DISPLAY TUBE CP3023GR
sR2	49346000	A.R. 7X 10 KΩ
sR3	49346000	A.R. 7X 10 KΩ
sC4	49299400	E.C. 5.5V 0.047 μF
sC9	49416900	C.C. 50V 0.047 μF
sC11	48663200	C.C. 50V 330 PF
sC13	48663200	C.C. 50V 330 PF
sC18	48663200	C.C. 50V 330 PF
sC19	49417000	C.C. 50V 0.1 μF
sC20	49417000	C.C. 50V 0.1 μF
sL1	46205100	INDUCTOR 100 μH

F-6996. VOLUME CONTROL

BOARD

<Stock No. 01369601> (RZ-5900)

<Stock No. 01370601> (RZ-3900)

Parts No.	Stock No.	Description
• TRANSISTOR		
jQ21	46540801	2SC2878
	or 46604301	2SC3327
• IC		
jIC21	48982600	LB1641
• ZENER DIODE		
jDZ21	49676100	MTZJ5.1A
	or 49676200	MTZJ5.1B

Parts No.	Stock No.	Description
jVR24	49917700	V.R.

F-6997. POWER SW. BOARD

Parts No.	Stock No.	Description
NLD1	49378800	L.E.D. SEL2210S
oS22	49326300	PUSH SW. SKHVBF 5H160G

F-6998. MAIN BOARD

<Stock No. 01369001> (RZ-5900)
 <Stock No. 01370001> (RZ-3900)

Parts No.	Stock No.	Description
dZ1	49592200	FM PACK FE337-A07 (XX, SS)
	or 49592100	FM PACK FE415-G11 (EU, IPT, GE)

• TRANSISTOR

dQ1	46393201	2SC2786
dQ2	48840500	DTC314TS
dQ3	46719800	DTA124ES
dQ4	46719800	DTA124ES
dQ5	46834300	DTC144ES
	or 49388300	RN1204
dQ6	46834300	DTC144ES
	or 49388300	RN1204
dQ7	46834300	DTC144ES
	or 49388300	RN1204
dQ8	46834300	DTC144ES
	or 49388300	RN1204
dQ9	46834200	DTA144ES
	or 49390500	RN2204
dQ10	46834300	DTC144ES
	or 49388300	RN1204

• IC

dIC1	48715100	LA1266
dIC2	48491000	LA3410A
dXO1	48272800	CERAMIC OSC ELEMENT CSB456

Parts No.	Stock No.	Description
-----------	-----------	-------------

• DIODE

dD1 to 12	46464100	1SS133
△ dR10	49850900	N.I.R. 1/2W 10'
△ dR17	49851300	N.I.R. 1/2W 22
△ dR38	49851300	N.I.R. 1/2W 22
dC1	48426900	C.C. 25V 22000 PF
dC4	48426900	C.C. 25V 22000 PF
dC5	48426900	C.C. 25V 22000 PF
dC6	48426900	C.C. 25V 22000 PF
dC7	48426900	C.C. 25V 22000 PF
dC9	48662600	C.C. 50V 100 PF
dC10	48662600	C.C. 50V 100 PF
dC11	48103700	E.B. 50V 4.7 μF
dC13	49416900	C.C. 50V 0.047μF
dC22	49416900	C.C. 50V 0.047μF
dCF1	46202500	CERAMIC FILTER SFE10.7MS2 RED (XX, SS)
	or 48064800	CERAMIC FILTER SFE10.7MS3G RED (EU, IPT, GE)
dCF2	46202500	CERAMIC FILTER SFE10.7MS2 RED (XX, SS)
	or 48064800	CERAMIC FILTER SFE10.7MS3G RED (EU, IPT, GE)
dLP1	49914800	LOW PASS FILTER (19/38KHZ)
dT1	49912100	FM IF COIL
dT2	49912200	FM IF COIL
dT3	49632000	ADJ. CH. FL (IPT, GE)
dVR1	83333900	S.V.R.
dVR2	83334000	S.V.R.
eD1	46708400	VOLTAGE V.C. DIODE SVC321
• DIODE		
eD2	46464100	1SS133
eC2	49416900	C.C. 50V 0.047μF
eC3	49416900	C.C. 50V 0.047μF
eC6	49416900	C.C. 50V 0.047μF
eC7	48426900	C.C. 25V 22000 PF
eC8	48426900	C.C. 25V 22000 PF
eC11	48426900	C.C. 25V 22000 PF
eC12	48666200	C.C. 16V 0.01 μF

<F-6998>

Parts No.	Stock No.	Description
eC13	49416900	C.C. 50V 0.047μF
eC14	48663800	C.C. 50V 1000 PF
eC16	48426900	C.C. 25V 22000 PF
eTC1	46095700	TRIMMER CAPACITOR 30PF
or	46162900	TRIMMER CAPACITOR 30PF
eTC2	46095700	TRIMMER CAPACITOR 30PF
or	46162900	TRIMMER CAPACITOR 30PF
eCF1	48865700	CERAMIC FILTER BFGFL-450
eT1	49594600	AM RF COIL
or	83295500	AM RF COIL
eT2	49591800	AM RF COIL
or	83228100	MW OSC COIL P-7SB
or	83295400	AM RF COIL
eT3	48072000	AM IF COIL
eVR1	83334000	S.V.R.
• TRANSISTOR		
fQ1	46367301	2SC2458
or	48058801	2SC1740S
• FET		
fFT1	46643501	2SK163-K2
or	46643502	2SK163-L1
or	46643601	2SK117-Y
or	46643602	2SK117-GR
• IC		
fIC1	49317500	LC7218
fXO1	49837400	QUARTZ ELEMENT 7.200M
fIR16	49852100	N.I.R. 1/2W 100
fC3	48426900	C.C. 25V 22000 PF
fC4	48103500	E.B. 50V 2.2 μF
fC5	48663800	C.C. 50V 1000 PF
fL1	49797600	INDUCTOR
• IC		
iIC1	07208900	NJM4558D-X

Parts No.	Stock No.	Description
Δ IR10	49852100	N.I.R. 1/2W 100
Δ IR11	49852100	N.I.R. 1/2W 100
IC3	48663000	C.C. 50V 220 PF
• IC		
jIC1	03607700	NJM4558D
jC3	48660200	C.C. 50V 47 PF
jC5	48660200	C.C. 50V 47 PF
jC8	48662600	C.C. 50V 100 PF
• IC		
Δ kIC1	49918400	STK4204MK5 (RZ-5900)
Δ kIC1	49918300	STK4184MK5 (RZ-3900)
Δ KR4	49852100	N.I.R. 1/2W 100
Δ KR7	49852100	N.I.R. 1/2W 100
Δ KR15	49864100	N.I.R. 1W 10
Δ KR16	49880100	N.I.R. 2W 1K
KC2	48663000	C.C. 50V 220 PF
KC17	48663400	C.C. 50V 470 PF (RZ-5900)
KC18	49416900	C.C. 50V 0.047μF
KL1	46851901	COIL 0.82 μH
• DIODE		
ID1	03117600	1S2473
IRL1	49658800	RELAY
• TRANSISTOR		
Δ mQ2	46581601	2SA 992
• IC		
Δ miC1	49440800	NJM78M12FA
Δ miC2	49440800	NJM78M12FA (RZ-5900)
• DIODE		
Δ mD1	46273600	DBB10B
mD2	48123600	11E2
Δ mD3	49708100	D3SBA20
• ZENER DIODE		
mDZ1	46827400	RD12E-B1
or	46827500	RD12E-B2
mDZ2	46830500	RD30E-B1
or	46830600	RD30E-B2

<F-6998>

Parts No.	Stock No.	Description
mDZ3	46824600	RD5.1E-B1
	or 46824700	RD5.1E-B2
Δ mR1	49849700	N.I.R. 1/2W 1
Δ mR2	49849700	N.I.R. 1/2W 1
Δ mR3	49852700	N.I.R. 1/2W 330
Δ mR5	49853600	N.I.R. 1/2W 1.8K
Δ mR6	49850500	N.I.R. 1/2W 4.7
Δ mR7	49850500	N.I.R. 1/2W 4.7
Δ mR8	49852100	N.I.R. 1/2W 100
Δ mR9	49852100	N.I.R. 1/2W 100
mC6	08680400	0.01 μF 500V C.C.
mC7	49417500	E.C. 63V 6800 μF
mC8	49417500	E.C. 63V 6800 μF
• IC		
oIC1	49312200	TC9163N ANALOG SW.
oC1	49428400	C.C. 16V 4700 PF (XX, SS)
	or 49574100	C.C. 16V 4200 PF (XX, SS)
oS34	49599400	SLIDE SW. (XX, SS)
qZ4	49623000	TERMINAL BOARD 2P
qZ5	48864700	TERMINAL BOARD 6P
qZ6	49588200	TERMINAL BOARD 6P
qZ3	48848600	ANTENNA TERMINAL (XX, SS)
	or 48848500	ANTENNA TERMINAL (EU, GE)
qZ7	83364300	8P TERMINAL

F-6999. POWER SUPPLY BOARD

<Stock No. 01369101> (RZ-5900)

<Stock No. 01370101> (RZ-3900)

Parts No.	Stock No.	Description
• TRANSISTOR		
mQ1	48223100	DTC114TS
	or 49389000	RN1211
mQ3	46367101	2SC2603
	or 48058801	2SC1740S

Parts No. Stock No. Description

• FET		
mFT1	46643501	2SK163-K2
	or 46643502	2SK163-L1
	or 46643602	2SK117-GR
• IC		
Δ mIC3	49440400	NJM78M05FA
• DIODE		
mD6	48123600	11E2
Δ mD9	46273600	DBB10B
mD10	46464100	1SS133
mD11	46464100	1SS133
mD12	46464100	1SS133 (XX, SS)
• ZENER DIODE		
mDZ4	49679300	MTZJ13B (XX, SS)
mDZ5	49675900	MTZJ4.7B (XX, SS)
	or 49676000	MTZJ4.7C (XX, SS)
Δ mF1	49593800	FUSE 3.15A (XX, SS) (RZ-5900)
Δ	or 49297400	FUSE T3.15A 250V (EU, GE) (RZ-5900)
Δ mF2	49593800	FUSE 3.15A (XX, SS) (RZ-5900)
Δ mF1	49593600	FUSE 2A (XX, SS) (RZ-3900)
Δ	or 49297200	FUSE 2A (EU, IPT, GE) (RZ-3900)
Δ mF2	49593600	FUSE 2A (XX, SS) (RZ-3900)
Δ mPT2	15040001	POWER TRANSFORMER A3370 XX-B (XX, SS)
Δ	or 15040005	POWER TRANSFORMER A3371 EU-B (EU, GE)
Δ pC1	48733400	4700 PF 400V C.C.
pS1	49912600	SLIDE SW. (XX, SS)
pRL1	83364400	RELAY
Δ pZ4	49745300	AC OUTLET (XX, SS)
Δ	49723000	AC OUTLET (EU, IPT, GE)
Δ pZ9	38005700	POWER SUPPLY CORD (XX)
Δ	48837700	POWER SUPPLY CORD (SS)
Δ	49299300	POWER SUPPLY CORD (EU, IPT, GE)

F-7001. CONTROL JACK BOARD

Parts No.	Stock No.	Description
• DIODE		
mD4	48123600	11E2 (RZ-5900)
mD5	48123600	11E2 (RZ-5900)
mD7	48123600	11E2 (RZ-3900)
mD8	48123600	11E2 (RZ-3900)
oS32	49442310	SLIDE SW.
oJ2	48985400	MINI JACK
oJ3	48985400	MINI JACK

**F-7002. SPEAKER SW. & HEAD
PHONES BOARD**

Parts No.	Stock No.	Description
△ kR17	49865700	N.I.R. 1W 220 (RZ-5900)
△ kR17	49852500	N.I.R. 1/2W 220 (RZ-3900)
oS33	49917600	PUSH SW.
oJ1	83265000	JACK

**F-7048. VILTAGE REGURATOR
TR BOARD**

Parts No.	Stock No.	Description
• TRANSISTOR		
△ mQ4	48509401	2SD1761 (XX, SS)

RZ-5900 Only

F-7000. VIDEO BOARD

<Stock No. 01369201>

Parts No.	Stock No.	Description
qZ8	49917500	TERMINAL BOARD
• TRANSISTOR		
rQ1	46367101	2SC2603
	or 48058801	2SC1740S
rQ2	46367101	2SC2603
	or 48058801	2SC1740S
rQ3	46834300	DTC144ES
rQ4	46367101	2SC2603
	or 48058801	2SC1740S
• IC		
rIC1	49475500	NJM2245D
rR15	49851500	N.I.R. 1/2W 33
rC1	48662600	C.C. 50V 100 PF
rC2	48662600	C.C. 50V 100 PF

7. OTHER PARTS

• FRONT VIEW

Parts No.	Stock No.	Description	Parts No.	Stock No.	Description
1	85116000	KNOB, POWER	10	85116800	KNOB LENZ, VOLUME
2	85117100	LENZ, STANDBY	11	85116700	KNOB, VOLUME
3	05051200	LOGO BADGE H5 G	12	85117000	KNOB, BASS/TREBLE/BALANCE
4	85115400	FRONT PANEL (RZ-5900)	13	85047300	LEG
4	85115500	FRONT PANEL (RZ-3900)	14	84650100	LEG SHEET
5	85116300	KNOB, FM/AM, P. SCAN	15	85116500	KNOB, AUTOMANU,
6	85115600	WINDOW	16	85116500	KNOB, MEMORY,
7	85117300	KNOB, SELECTOR	17	85116100	KNOB, TUNNING
8	85127100	BONNET (RZ-5900/3900)	18	85115700	KNOB, TEN KEY 6 - 9, 10/0 >10
or 85141700	85141700	BONNET (EU, GE) (RZ-5900)	19	85115800	KNOB, TEN KEY 1 - 5
9	85117500	TONE DEFEET / LOUDNESS	20	85117500	KNOB, SPEAKER A/B,

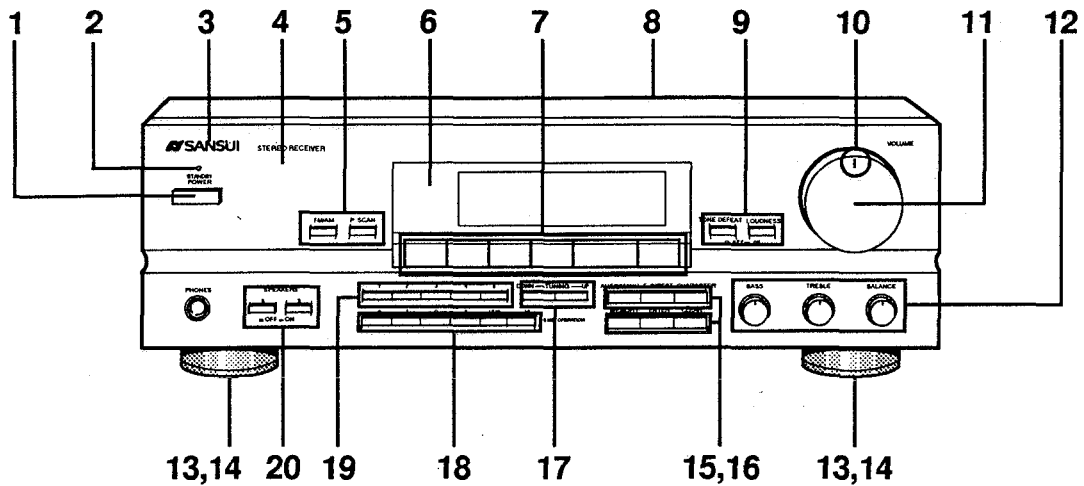

• TOP VIEW

Parts No.	Stock No.	Description
△ mPT1	83335501	POWER TRANSFORMER (XX, SS), (RZ-5900)
△	or 83335505	POWER TRANSFORMER (EU, GE), (RZ-5900)
△	83335601	POWER TRANSFORMER (XX, SS), (RZ-3900)
△	or 83335605	POWER TRANSFORMER (EU, IPT, GE), (RZ-3900)

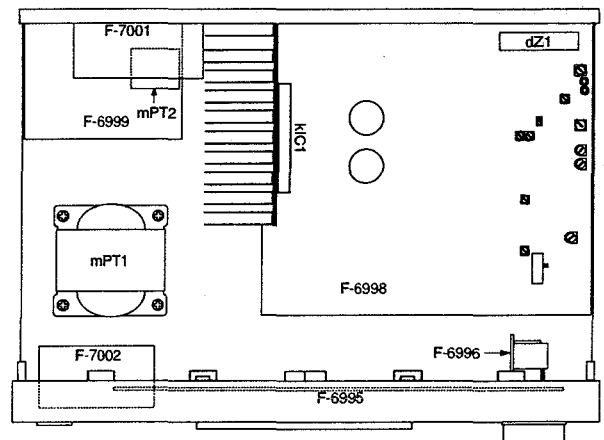

8. PACKING LIST

Parts No.	Stock No.	Description
1	85129200	CARTON CASE (RZ-5900)
1	85129300	CARTON CASE (RZ-3900)
2	85128900	STYROFOAM PACKING (R)
3	85129500	POLY SHEET
4	85129400	POLY BAG
5	85129000	STYROFOAM PACKING (L)

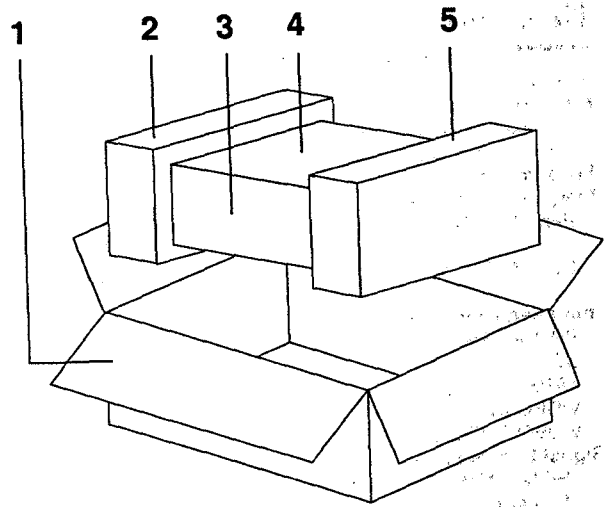

9. ACCESSORY LIST

Stock No.	Description
49919200	REMOTE CONTROL UNIT RS-1570 BATTERY ASSY (2PC)
83041000	AM LOOP ANTENNA
46051700	FM ANTENNA WIRE
49335000	ANTENNA CONNECTOR (EU, GE)
82029300	OPERATING INSTRUCTIONS (E. S. T.), (RZ-5900)
82029400	OPERATING INSTRUCTIONS (E. F. S. G. I. Sw. N. P.), (RZ-5900)
82029100	OPERATING INSTRUCTIONS (E. S. T.), (RZ-3900)
82029200	OPERATING INSTRUCTIONS (E. F. S. G. I. Sw. N. P.), (RZ-3900)

• NOTE

E.S.T. : English, Spanish and Old Chinese Character Version.
 E.F.S.G.I.Sw.N.P. : English, French, Spanish, German, Italian, Swedish,
 Netherlands and Portuguese Version.

Specifications

RZ-5900

Power output

Min. RMS, both channels driven, from 20 to 20,000 Hz, with no more than 0.05% total harmonic distortion.

70 watts per channel into 8 ohms.

Load impedance 4 to 16 ohms

Frequency response

PHONO (MM) 20 to 20,000 Hz, +0.5 dB, -0.5 dB
(at 1 watt)

CD, TAPE-1,2, LINE/LD ... 10 to 70,000 Hz, +1 dB, -3 dB
(at 1 watt)

Input sensitivity and impedance (at 1 kHz)

PHONO (MM) 2.5 mV/47 kohms

CD 200 mV/47 kohms

TAPE-1,2, LINE/LD 150 mV/47 kohms

VIDEO IN (LD, VCR) 1 V p-p / 75ohms

VIDEO OUT (VCR, MONITOR) 1 V p-p / 75ohms

Signal to noise ratio (Over all, 0 dB=1 watt, A-network)

PHONO (MM) 73 dB

CD, TAPE-1,2, LINE/LD ... 90dB

Controls

BASS ±8 dB at 50 Hz

TREBLE ±8 dB at 10 kHz

LOUDNESS (VOLUME: -30dB position)

..... +10 dB at 50 Hz

..... +6 dB at 10 kHz

FM Section

Tuning range 87.5 to 108 MHz

Usable sensitivity

Mono 11.2 dBf (2.0 μV/IHF T-100)

50 dB quieting sensitivity

Mono 17.2 dBf

Stereo 38.2 dBf

Signal to noise ratio at 65 dBf

Mono 76 dB

Stereo 70 dB

Distortion at 65 dBf

Mono less than 0.2 % at 1,000 Hz

Stereo less than 0.3 % at 1,000 Hz

Stereo separation 40 dB at 1,000 Hz

Frequency response 30 to 15,000 Hz +1 dB, -3 dB

Antenna input impedance . 75 ohms unbalanced

300 ohms balanced

AM Section

Tuning range 531 to 1,602 kHz (9 kHz)

530 to 1,710 kHz (10 kHz)

Usable sensitivity 55 dB/m (562 μV/m)

Signal to noise ratio 45 dB (antenna input 85 dB/m)

Others

Power requirements. 120 V/220 V/240 V

50/60 Hz

For U.S.A. and Canada 120 V (60 Hz)

Power consumption 300 watts

Dimensions 430 mm (16-15/16") W

133 mm (5-1/4") H

340 mm (13-7/16") D

Weight 7.9 kg (17.4 lbs) net

RZ-3900

Power output

Min. RMS, both channels driven, from 20 to 20,000 Hz, with no more than 0.09% total harmonic distortion.

40 watts per channel into 8 ohms.

Load impedance 4 to 16 ohms

Frequency response

PHONO (MM) 20 to 20,000 Hz, +0.5 dB, -0.5 dB
(at 1 watt)

CD, TAPE-1,2, LINE/LD ... 10 to 70,000 Hz, +1 dB, -3 dB
(at 1 watt)

Input sensitivity and impedance (at 1 kHz)

PHONO (MM) 2.5 mV/47 kohms

CD 200 mV/47 kohms

TAPE-1,2, LINE/LD 150 mV/47 kohms

Signal to noise ratio (Over all, 0 dB=1 watt, A-network)

PHONO (MM) 73 dB

CD, TAPE-1,2, LINE/LD ... 90dB

Controls

BASS ±8 dB at 50 Hz

TREBLE ±7 dB at 10 kHz

LOUDNESS (VOLUME: -30dB position)

..... +10 dB at 50 Hz

..... +6 dB at 10 kHz

FM Section

Tuning range 87.5 to 108 MHz

Usable sensitivity

Mono 13.2 dBf (2.5 μV/IHF T-100)

50 dB quieting sensitivity

Mono 18.0 dBf

Stereo 40 dBf

Signal to noise ratio at 65 dBf

Mono 76 dB

Stereo 70 dB

Distortion at 65 dBf

Mono less than 0.3 % at 1,000 Hz

Stereo less than 0.5 % at 1,000 Hz

Stereo separation 40 dB at 1,000 Hz

Frequency response 30 to 15,000 Hz +1 dB, -3 dB

Antenna input impedance . 75 ohms unbalanced

300 ohms balanced

AM Section

Tuning range 531 to 1,602 kHz (9 kHz)

530 to 1,710 kHz (10 kHz)

Usable sensitivity 55 dB/m (562 μV/m)

Signal to noise ratio 40 dB (antenna input 85 dB/m)

Others

Power requirements. 120 V/220 V/240 V

50/60 Hz

For U.S.A. and Canada 120 V (60 Hz)

Power consumption 200 watts

Dimensions 430 mm (16-15/16") W

133 mm (5-1/4") H

340 mm (13-7/16") D

Weight 6.5 kg (14.3 lbs) net



SANSUI ELECTRIC CO.,LTD.:

J Tower 7F. 1-1 Nikko-cho, Fuchu-si Tokyo 183, Japan

PHONE: 0423-30-7412 / FAX: 0423-51-6163

SANSUI USA INC.:

17150 South Margay Ave. Carson, California 90746 U.S.A.

SANSUI DEUTSCHLAND G.M.B.H.:

Paul Ehrlich Strasse 8, 6074Rödermark 2, F. R. Germany

山水電気株式会社

東京都府中市日鋼町1番1 Jタワー7F(〒183)

R2890/2900

(SM 2-377)

Printed in Japan (1993.12.P)

<Stock No.36572100>