

SANSUI SERVICE MANUAL

RZ-8100AV

A/V RECEIVER with SURROUND Circuit
For World Market Model, Black Color.

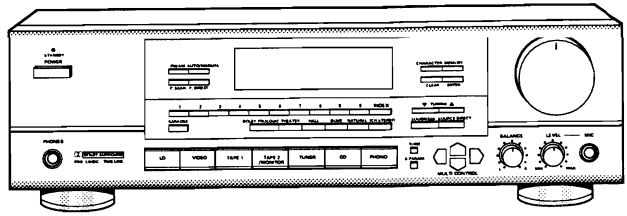

RZ-8150AV

A/V RECEIVER with SURROUND Circuit
For World Market Model, Gold Color.

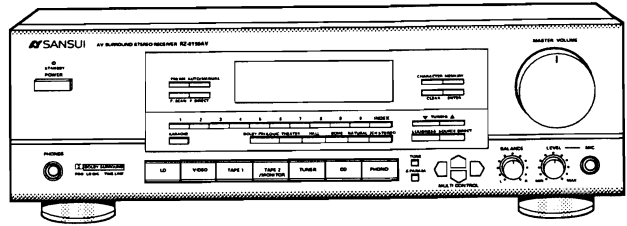

AV-7100

A/V AMPLIFIER with SURROUND Circuit
For World Market Model, Black Color.

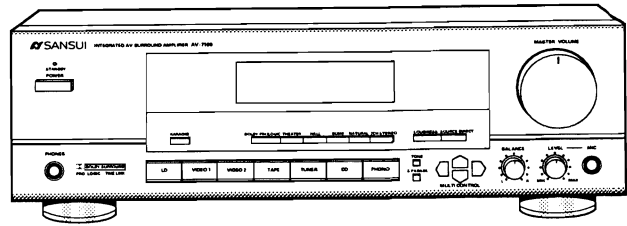

AV-7150

A/V AMPLIFIER with SURROUND Circuit
For World Market Model, Gold Color.

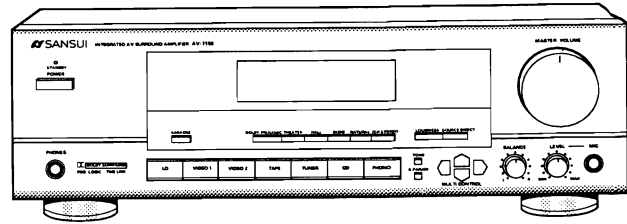

AV-7700

A/V AMPLIFIER with SURROUND Circuit
This Model is For Japan Market Only!!

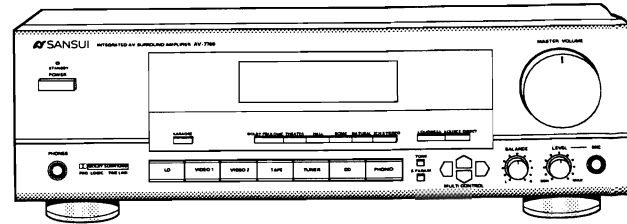

Variation of Two Colors (Black & Gold). この製品は、日本国内向け専用です。

- Design and specifications subject to changes without notice for improvements.
- Due to local laws and regulations, this unit sold in some areas are not equipped with variable voltage selector.
- 本機の意匠及び仕様の一部は、改良の為、予告無く変更する事が有ります。

- Dolby noise reduction manufactured under license from Dolby Laboratories Licensing Corporation.
- "DOLBY" and the double-D symbol  are trademarks of Dolby Laboratories Licensing Corporation.
- ドルビー、DOLBY、ダブルD記号  は、ドルビー・ラボラトリーズ・ライセンシング・コーポレーションの登録商標です。
- 本機は、ドルビー・ラボラトリーズ・ライセンシング・コーポレーションからの実施権に基づき製造されて居ます。

AV-7700

AV-7150

AV-7100

RZ-8150AV

RZ-8100AV

CAUTION (注意)

1. Parts identified the Δ symbol on the schematic diagram and the parts list are critical for safety. Use only replacement parts that have critical characteristics recommended by the manufacturer.
 2. Make leakage-current for resistance measurements to determine that exposed parts are acceptably insulated from the supply circuit before returning the appliance to the customer.
- Δ 印がついている部品は、安全性を維持するために、重要な部品です。
これらの部品を交換する際には、必ず指定された部品を使用して下さい。

Notice / 告知

The symbols, **OO**, **UL**, **CSA**, **SS**, **EU**, **IPT**, **FTZ** and **XX** on the parts list and the schematic diagram mean followings respectively.

日本国向け製品専用部品には"**OO**"マークが付いて居ます。

- OO** Manufactured for **Japanese** market.
 - UL** Manufactured for **U.S.A.** market. (Underwriters Laboratories approved model.)
 - CSA** Manufactured for **Canadian** market.
 - SS** Manufactured for **Saudi Arabian** market.
 - EU** Manufactured for **European** market.
 - IPT** Manufactured for **Italian** market.
 - FTZ** Manufactured for **F. R. Germanic** market.
 - XX** **Standard** Version.
 - ***(EXPORT)*** (Non **Japanese** market.)
 - Non Mark** **Common parts**.
- マークの無い部品は全仕向け共通です。

Table of Contents / 目次

2	Caution / 注意書
2	Notice / 告知
2	Table of contents / 目次
2	Guaide of model / 機種案内
3	Specifications / 仕様"#1"
5	Block Diagram / ブロック図"#2"
8	Schematic Diagram / 回路図"#3"
13	Adjustment / 調整方法 "#4"
15	Interior Block Diagram & terminal Function of ICs / IC の内部図"#5"
21	Parts Location on Printed Circuit Board / 基板の部品配置図"#6"
27	Parts List of Printed Circuit Board / プリント基板の部品表 "#7"
37	Mechanism Parts List / 機構部品表"#8"
39	Packing list / 梱包材部品表"#9"
39	Accessory List / 付属品部品表"#10"
40	Packing list / 梱包材部品表"#11"
40	Accessory List / 付属品部品表"#12"

Model name marker "**????**" in top of any page indicate be written of this model here. 各頁上部に記載されて居ます機種名の **記号** は、その機種に就いての記述が盛り込まれて居ることを示して居ます。

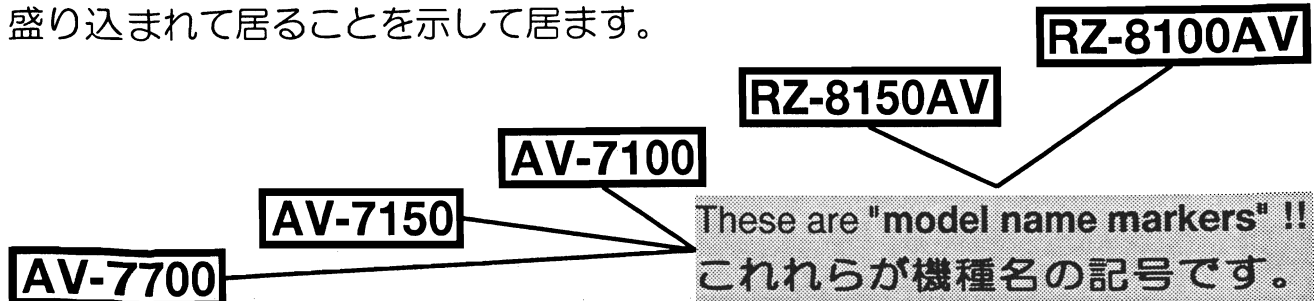

RZ-8100AV**RZ-8150AV****AV-7100****AV-7150**

1. SPECIFICATIONS

Tuner Department (For receiver only!! * For the other markets than Japanese!!)

F. M. (V. H. F. band) Section

Tuning range 87.5MHz to 108.0MHz
 (50.0kHz step)
 Usable sensitivity 14.8dBf (Monophonic)
 50dB quieting sensitivity 42.0dBf (Stereophonic)
 21.0dBf (Monophonic)
 Signal to noise ratio (at 65dBf) ... 65.0dB (Stereophonic)
 70.0dB (Monophonic)
 Frequency response 30Hz to 15kHz (± 1 dB)
 Total harmonic distortion with noise (at 65dBf, A. F. 1kHz)
 (Stereophonic) less than 0.5%
 (Monophonic) less than 0.4%
 Capture ratio 1.5dB
 Alternate channel selectivity 50.0dB (± 400 Hz)
 Spurious response ratio 70.0dB
 Image response ratio 40.0dB

I. F. response ratio 80.0dB
 R. F. intermodulation 55.0dB
 A. M. suppression ratio 50.0dB
 Stereo-separation (at 1kHz) 40.0dB
 Antenna input impedance 75 Ω (Unbalanced)

A.M. (M.F.) Section

Tuning range 531kHz to 1602kHz
 (9kHz step)
 530kHz to 1710kHz
 (10kHz step)
 Usable sensitivity(on loop antenna) 55dB/m
 Selectivity (difference ± 9 kHz) 20dB
 Signal to noise ratio (at 80dB/m) 45dB
 Total harmonic distortion with noise (at 80dB/m, 30% modulation)
 less than 0.7%

Amplifier Department

Main Amplifier Section

Output power (2 channels mode) (Front 2 channels driven)
 Power band width (at 20Hz~20kHz & less than 0.2% THD)
 (UL, SS & XX) 100Wr.m.s. each channel into 8 Ω
 (EU, IPT & FTZ) 50Wr.m.s. each channel into 8 Ω
 Rated power (at 1kHz & less than 0.03% T.H.D.)
 (UL, SS & XX) 115Wr.m.s. each channel into 8 Ω
 Rated power "D.I.N." (at 1kHz & less than 1% T.H.D.)
 (EU, IPT & FTZ) 100Wr.m.s. each channel into 4 Ω
 Output power (Surround mode) (All channels driven)
 Rated power (at 1kHz & less than 1% T.H.D.)
 (UL, SS & XX) Front 75Wr.m.s. each channels into 8 Ω
 Rear 25Wr.m.s. each channels into 8 Ω
 Center 75Wr.m.s. single channel into 8 Ω
 (EU, IPT & FTZ) Front 60Wr.m.s. each channels into 4 Ω
 Rear 25Wr.m.s. each channels into 8 Ω
 Center 60Wr.m.s. single channel into 4 Ω
 Load impedance
 (UL, SS & XX) 8 Ω ~16 Ω (Front & Center channel)
 (EU, IPT & FTZ) 4 Ω ~16 Ω (Front & Center channel)
 8 Ω ~16 Ω (Rear channel)

Pre Amplifier Section

Audio input sensitivity and impedance at 1kHz
 MICROPHONE 0.3mV / 10k Ω
 PHONO (M. M.) 2.5mV / 47k Ω
 The other input terminals 150mV / 47k Ω
 Maximum input capability (at 1kHz & less than 0.1% THD)
 PHONO (M. M.) 110mVr.m.s.
 Audio output voltage at 1kHz 150mVr.m.s. into 47k Ω
 Frequency response (Over-all at 1W)
 PHONO (M. M.) 20Hz to 20kHz (± 0.5 dB)
 The other input terminals 10Hz to 70kHz (± 1 dB)
 Signal to noise ratio (into I.H.F.-A 202 network at 1W)
 PHONO (M. M.) more than 74dB
 The other input terminals more than 78dB

Stereophonic channel separation (at 1kHz)
 PHONO (M. M.) 60dB
 The other input terminals 65dB
 Channel separation (at 1kHz) 75dB
 Tone controls
 BASS ± 10 dB (at 50Hz)
 TREBLE ± 10 dB (at 15kHz)
 Loudness control (at 30dB attenuate point from full volume)
 +9dB (at 50Hz), +6dB (at 10kHz)
 Audio muting -40dB (at 1kHz)

Surround Section

Sounds delay time 15~30mSec. (Dolby surround)
 5~50mSec. (Theater surround)
 5~100mSec. (The others)

Video Section

Input sensitivity and impedance ... 1 Vp-p / 75 Ω
 Output voltage and impedance 1 Vp-p / 75 Ω
 Frequency Response 5Hz to 10MHz (± 3 dB)

General Section (The others)

Power requirements
 UL A.C. 120V / 60Hz
 EU, IPT, FTZ A.C. 230V / 50Hz
 SS, XX A.C. 120, 220, 230 ~ 240V / 50, 60Hz
 Power consumption
 UL 390W / 490VA
 EU, IPT, FTZ 560W
 SS, XX 390W
 Dimensions Width 430mm / 16-15/16inches
 Height 144mm / 5-11/16inches
 Depth 350mm / 13-13/16inches
 Weight
 (Receiver) 11.5kg / 25.4 lbs (net)
 (Amplifier) 11.4kg / 25.1 lbs (net)

1. 仕様

主増幅(メイン・アンプ)部

出力(2チャンネル・モード) (フロント2チャンネル動作時)	
帯域実効出力 (20Hz~20kHz,全高調波歪率0.2%以内)	85Wr.m.s./6Ω
最大実効出力(EIAJ) (1kHz,全高調波歪率10%以内)	120Wr.m.s./6Ω
出力(サラウンド・モード) (全チャンネル動作時)	
最大実効出力(EIAJ) (1kHz,全高調波歪率10%以内)	
前面(フロント)	80Wr.m.s./6Ω
背面(リア)	30Wr.m.s./6Ω
中央(センター)	80Wr.m.s./6Ω
出力負荷インピーダンス	6Ω~16Ω

全置増幅(プリ・アンプ)部

入力感度/入力インピーダンス(1kHz)	
マイクロホン	0.3mVr.m.s./10kΩ
フォノ(M. M.)	2.5mVr.m.s./47kΩ
その他の入力端子	150mVr.m.s./47kΩ
最大許容入力 (1kHz,全高調波歪率0.1%以内)	
フォノ(M. M.)	110mVr.m.s.
出力電圧(1kHz)	150mVr.m.s./47kΩ
周波数特性 (スピーカー端子にて1Wr.m.s.)	
フォノ(M. M.)	20Hz~20kHz (±0.5dB)
その他の入力端子	10Hz~70kHz (±3dB)
S/N比 (1Wr.m.s.,I.H.F. A-202ネットワーク使用)	
フォノ(M. M.)	74dB以上
その他の入力端子	78dB以上
ステレオ・チャンネル・セパレーション(1kHz)	
フォノ(M. M.)	60dB
その他の入力端子	65dB
チャンネル・セパレーション(1kHz)	75dB
音質調整(トーン・コントロール)	
低域(バス)	±10dB(50Hz)
高域(トリアル)	±10dB(15kHz)
聴感補正(ラウドネス) (ポリューム30dB減衰時)	
低域	+9dB(50Hz)
高域	+6dB(10kHz)
オーディオ・ミューティング	-40dB(1kHz)

サラウンド部

音声遅延時間(サウンド・ディレイ・タイム)	
ドルビー・サラウンド	15~30mSec.
シアター・サラウンド	5~50mSec.
その他のサラウンド	5~100mSec.

映像(ビデオ)部

入力感度/入力インピーダンス	1Vp-p/75Ω
出力電圧/出力インピーダンス	1Vp-p/75Ω
周波数特性	5Hz~10MHz(±3dB)

総合部

電源電圧	A.C. 100V/50, 60Hz
定格消費電力	205W
製品寸法	
幅	430mm
高さ	144mm
奥行	350mm
製品質量	11.4kg

2. BLOCK DIAGRAM / ブロック図

2-1. System Control, Power Supply & Multi Channel Main Amplifiers / システム・コントロール、電源、多チャンネル主増幅器

POWER SUPPLY & POWER AMP

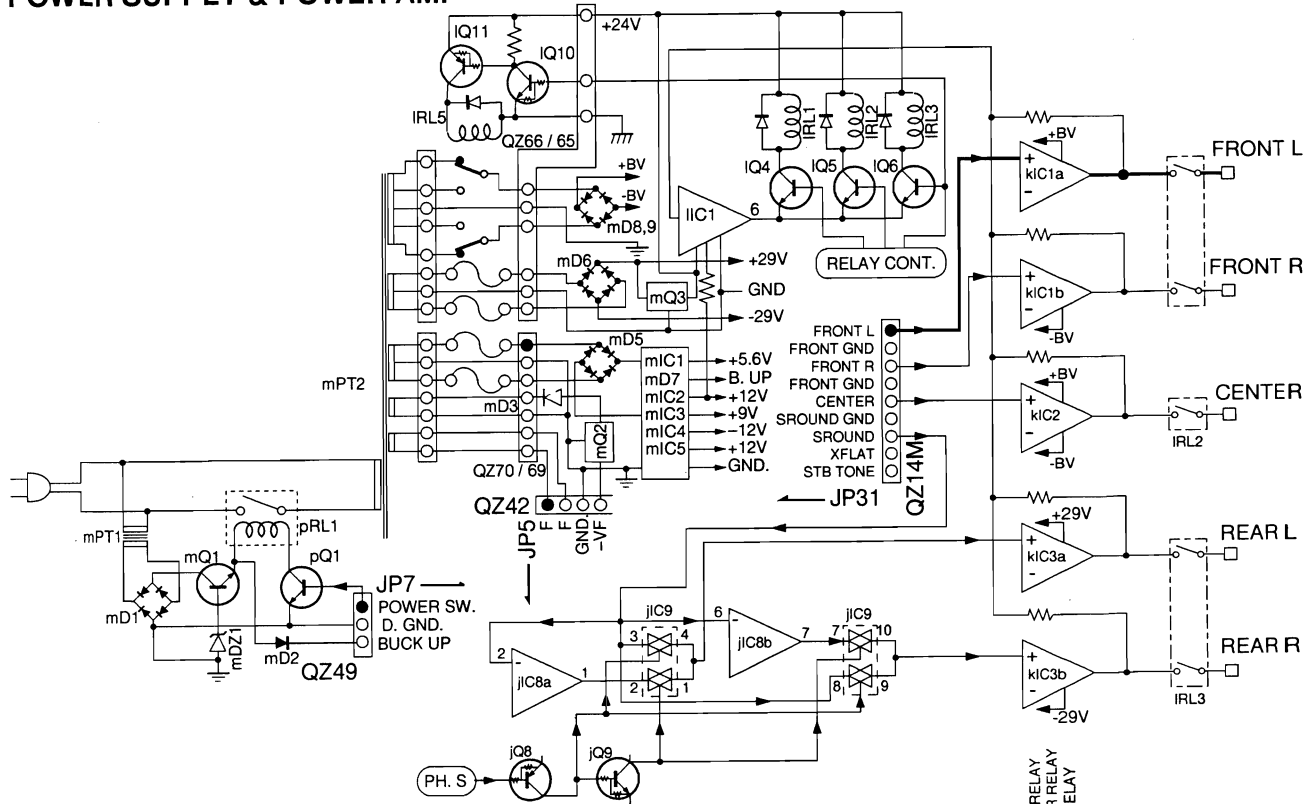

SYSTEM CONTROL

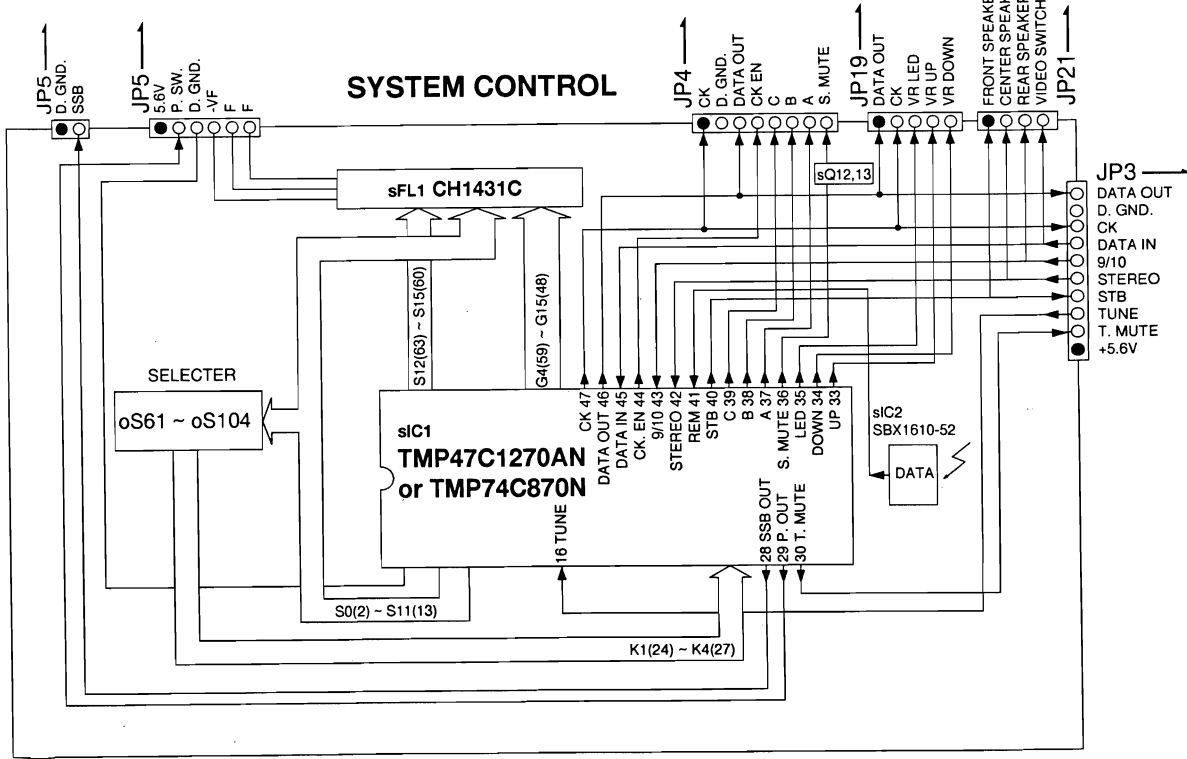

2-2. Tuner, Micro-phone, Video, Audio Selector & Pri Amplifier Circuit ／受信、マイク、ビデオ、音響切り替え及び前置増幅器回路

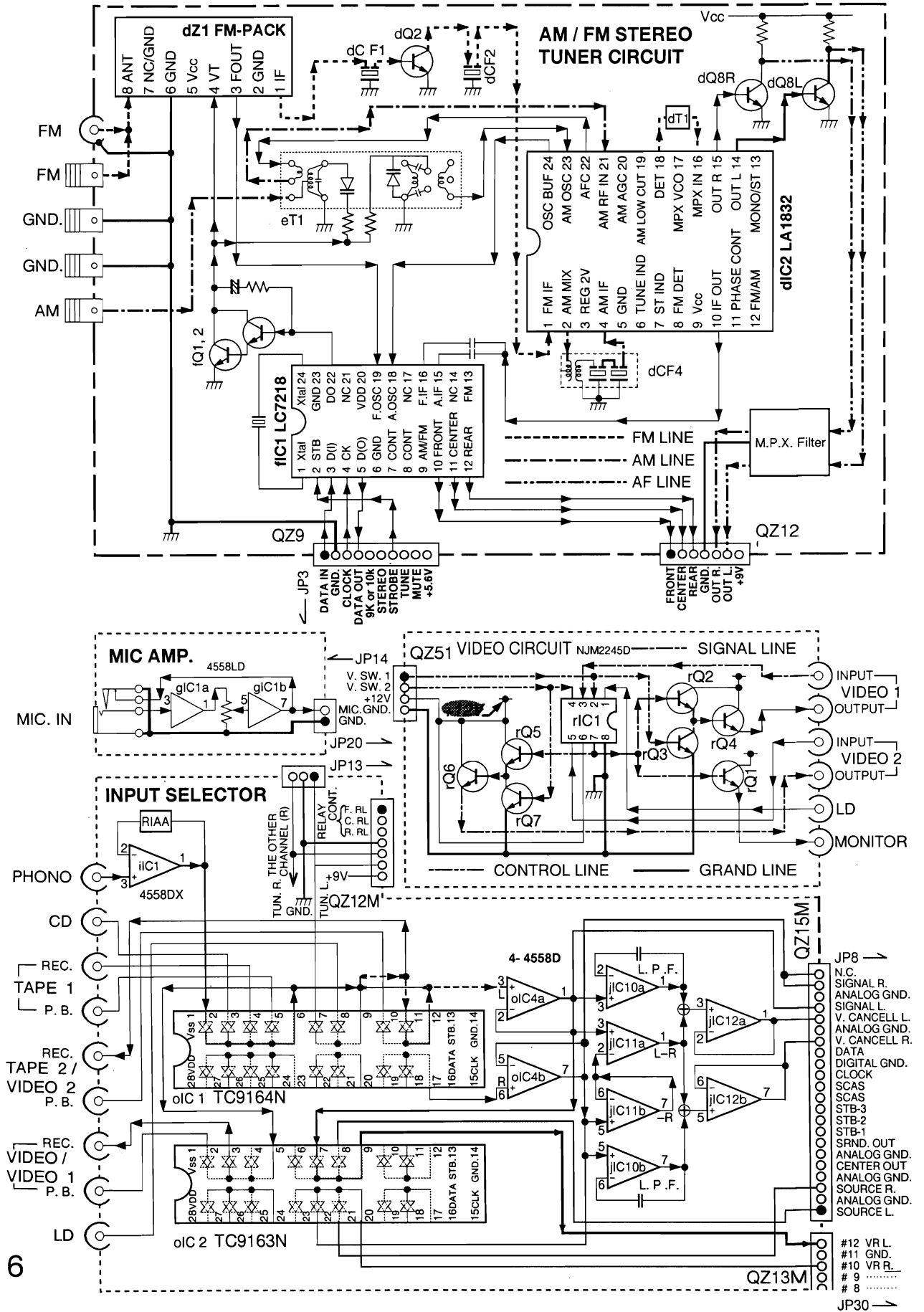

#12 VR L.
#11 GND.
#10 VR R.
#9
#8
JP30

RZ-8100AV

RZ-8150AV

AV-7100

AV-7150

AV-7700

2-3. Audio Control Circuit (Attenuation, Loudness, Tone, Surround)
 / 音響調整回路 (減衰量、聴感補正、音質、サラウンド)

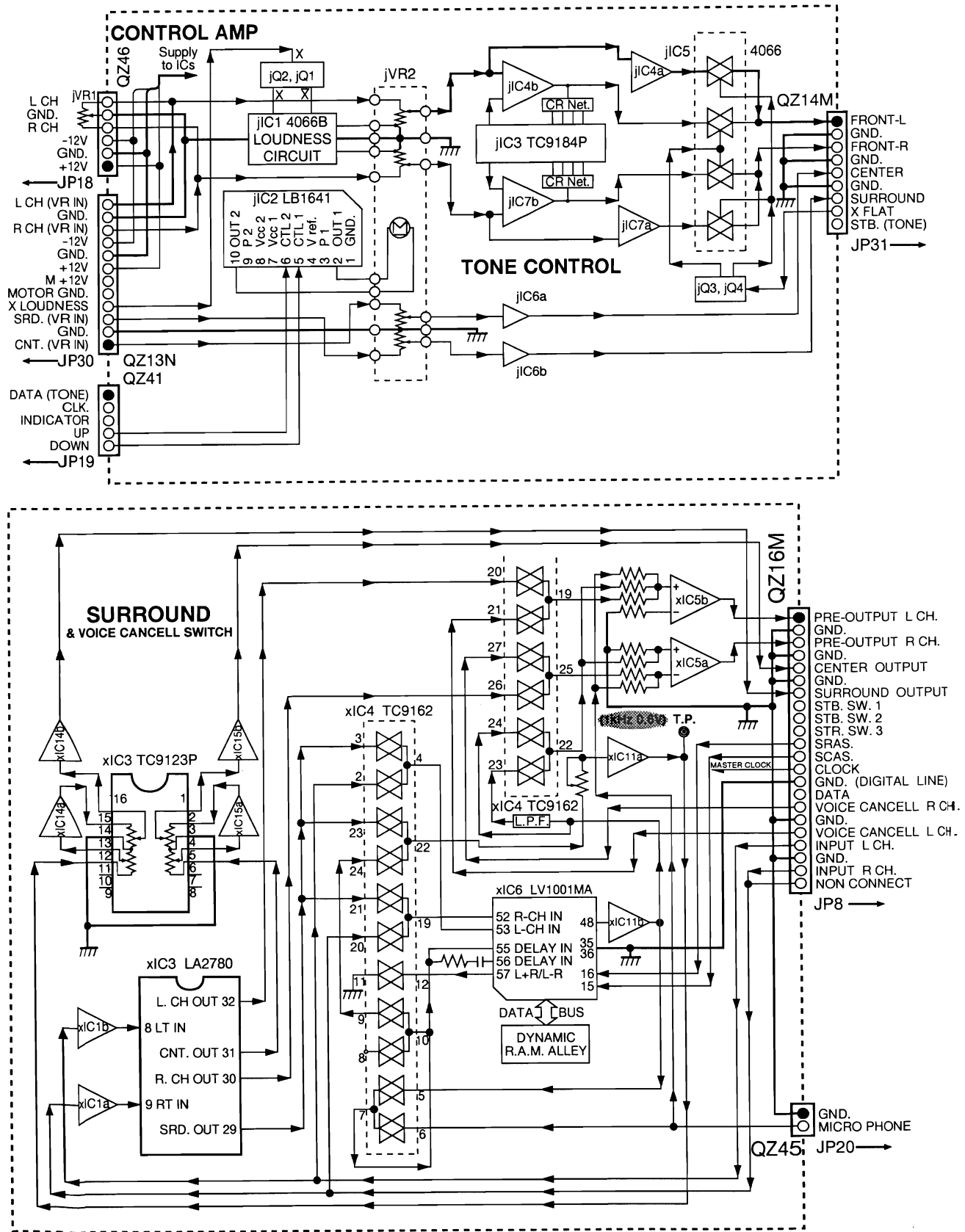

3. SCHEMATIC DIAGRAM / 回路図 3-1. Indicator Circuit / 表示回路

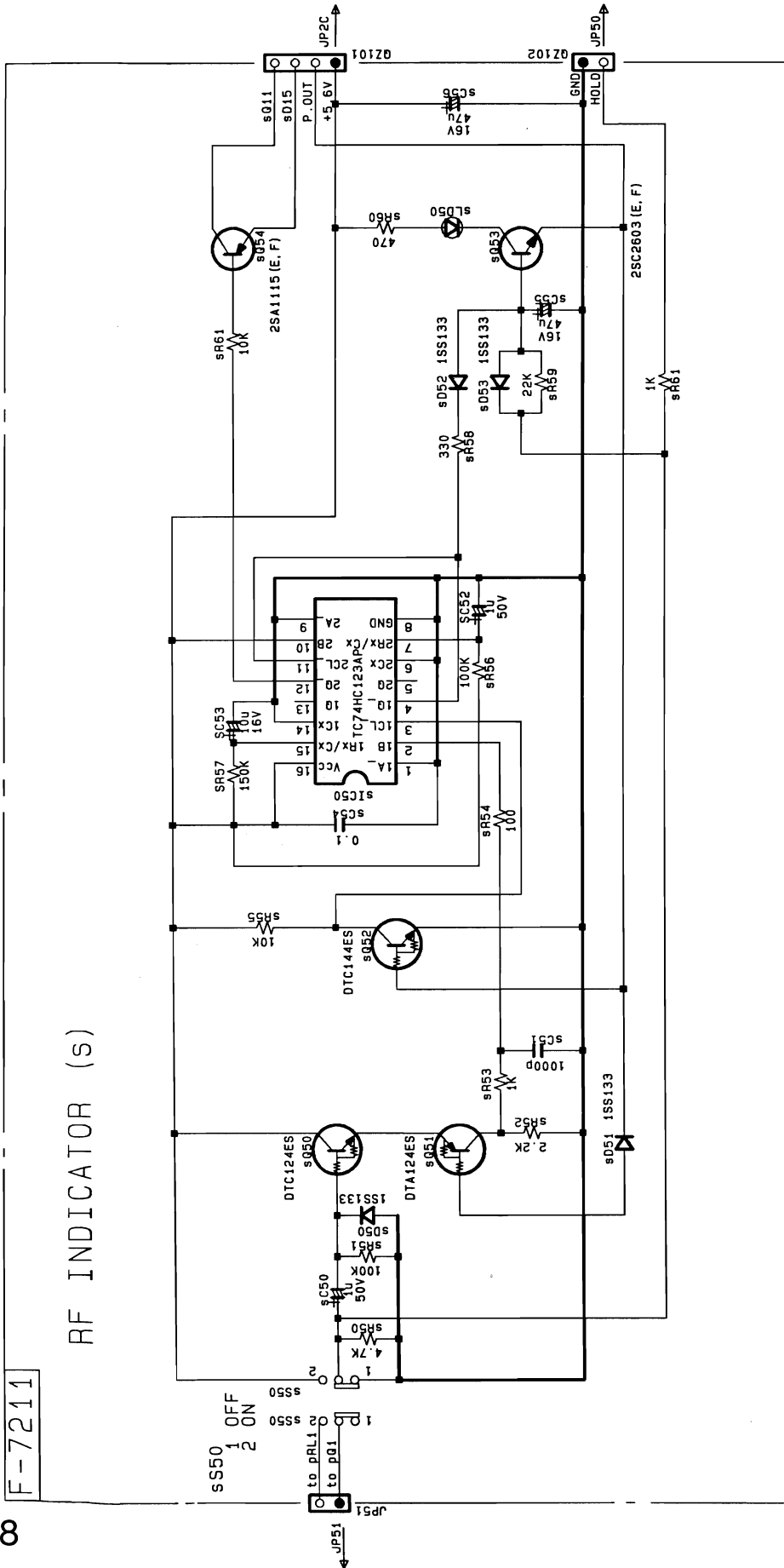

RF INDICATOR (S)

F-7211

SYMBOL OF FUNCTION

- (j) CONTROL
- (k) POWER AMP
- (l) PROTECTOR
- (m) POWER SUPPLY
- (o) SELECTOR
- (p) FIXED PARTS

RESISTORS
 Are in ohms, 1/6Watts, #5%Tolerance
 Unless Otherwise Noted. k:kilo Ohms

CAPACITORS
 Are in uF, Unless Otherwise Noted
 p: pF

Electrolytic Capacitor
 Capacitance (uF) / Voltage (V)

Each D.C Voltage shows the nominal value
 in volts at no input signal.

▲ is Safety part.
 Use only replacement parts
 recommended by manufacturer.

2-2. System Control Circuit, For A.C. Power Line Circuit & Power Transformer / システム・コントロール回路、電源一次回路及び、電源用変成器

• Design and specifications subject to changes without notice for improvements. • 本機の意匠 (デザイン) 及び仕様の一部は改良の為、予告無く変更する事が有ります。

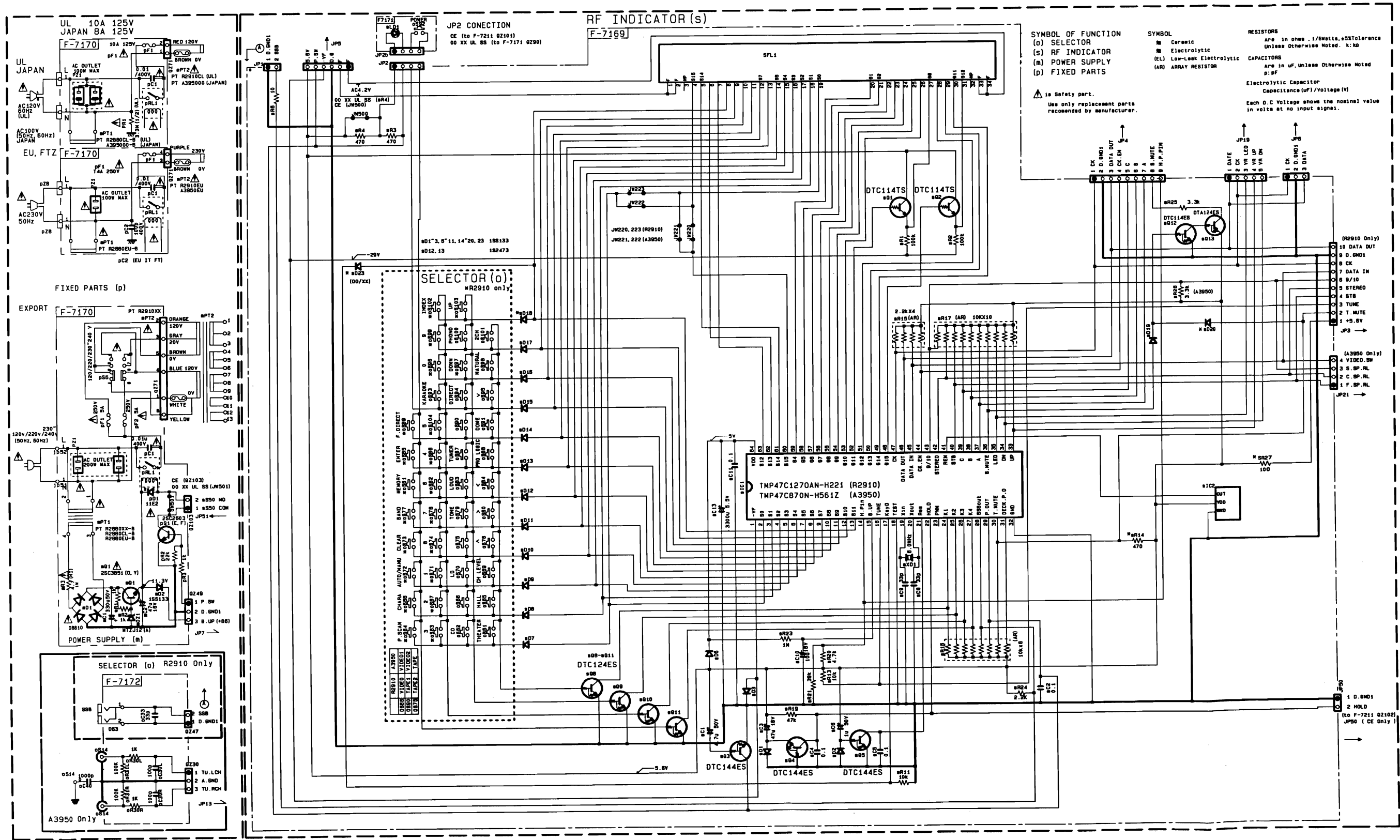

2-3. Analog Sound Control, Digital Signal Processor & Microphone Amplifier Circuit
 /音量・音質調整回路、デジタル・シグナル・プロセッサ回路及び、マイクロ・フォン増幅回路

・Design and specifications subject to changes without notice for improvements.
 ・本機の意匠(デザイン)及び仕様の一部は改良の為、予告無く変更する事が有ります。

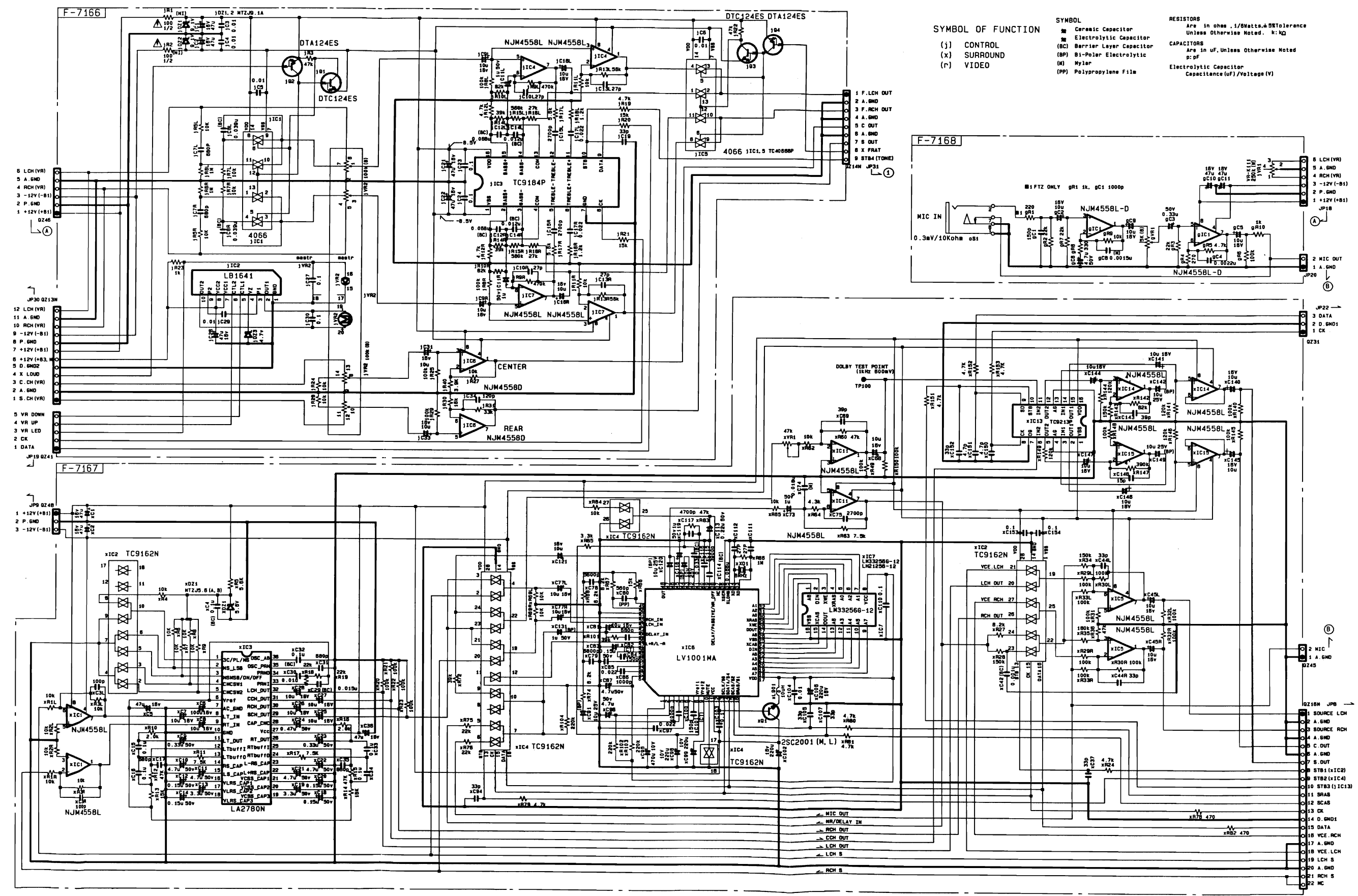

2-4. Input Selector, Amplifiers, Power Supply & Video Selector Circuit
 / 入力切り替え回路、増幅回路、電源回路及び、ビデオ切り替え回路

• Design and specifications subject to changes without notice for improvements.
 • 本機の意匠(デザイン)及び仕様の一部は改良の為、予告無く変更する事が有ります。

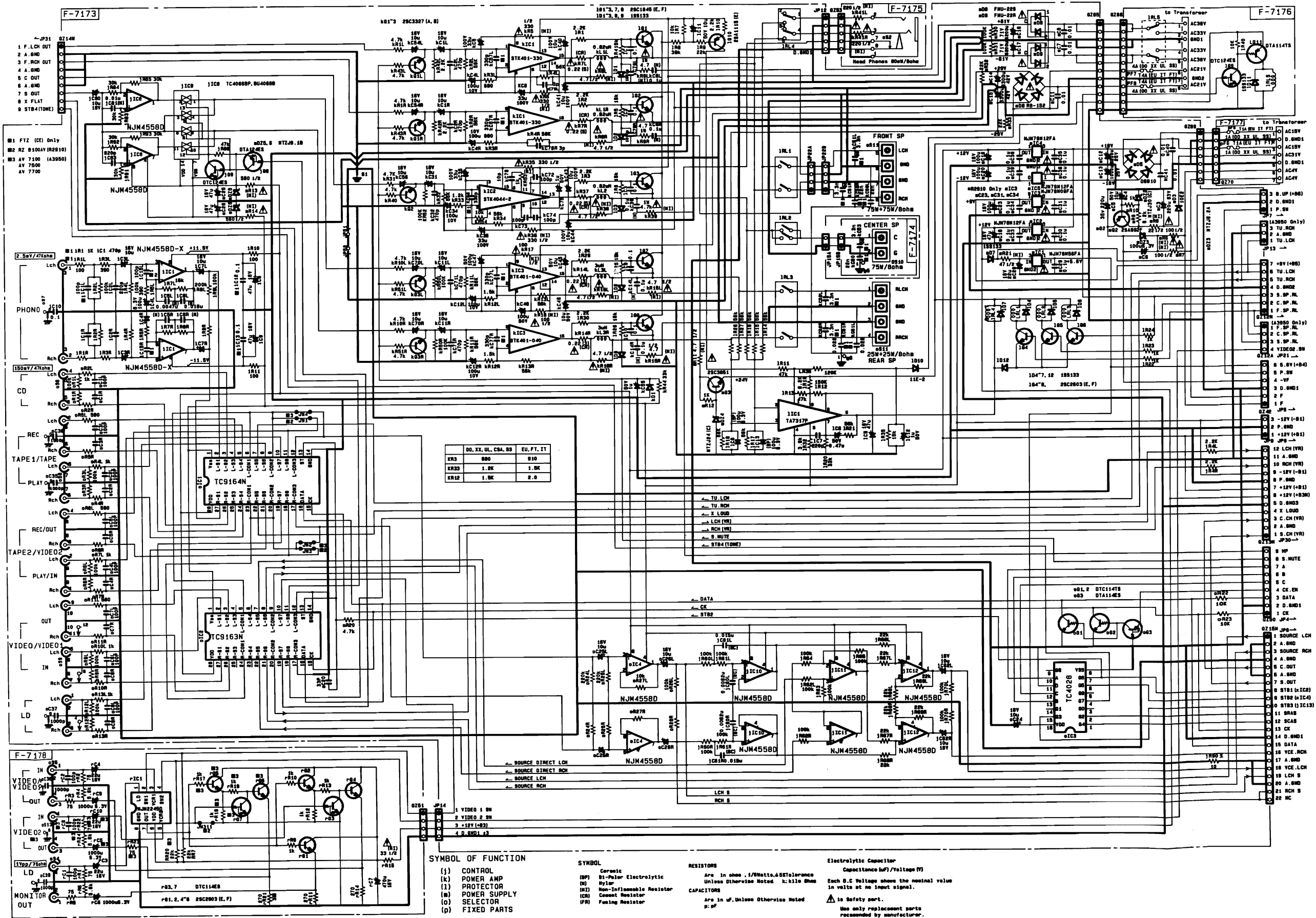

2-5. TUNER CIRCUIT / チューナー回路

• Design and specifications subject to changes without notice for improvements.
 • 本機の意匠 (デザイン) 及び仕様の一部は改良の為、予告無く変更する事が有ります。

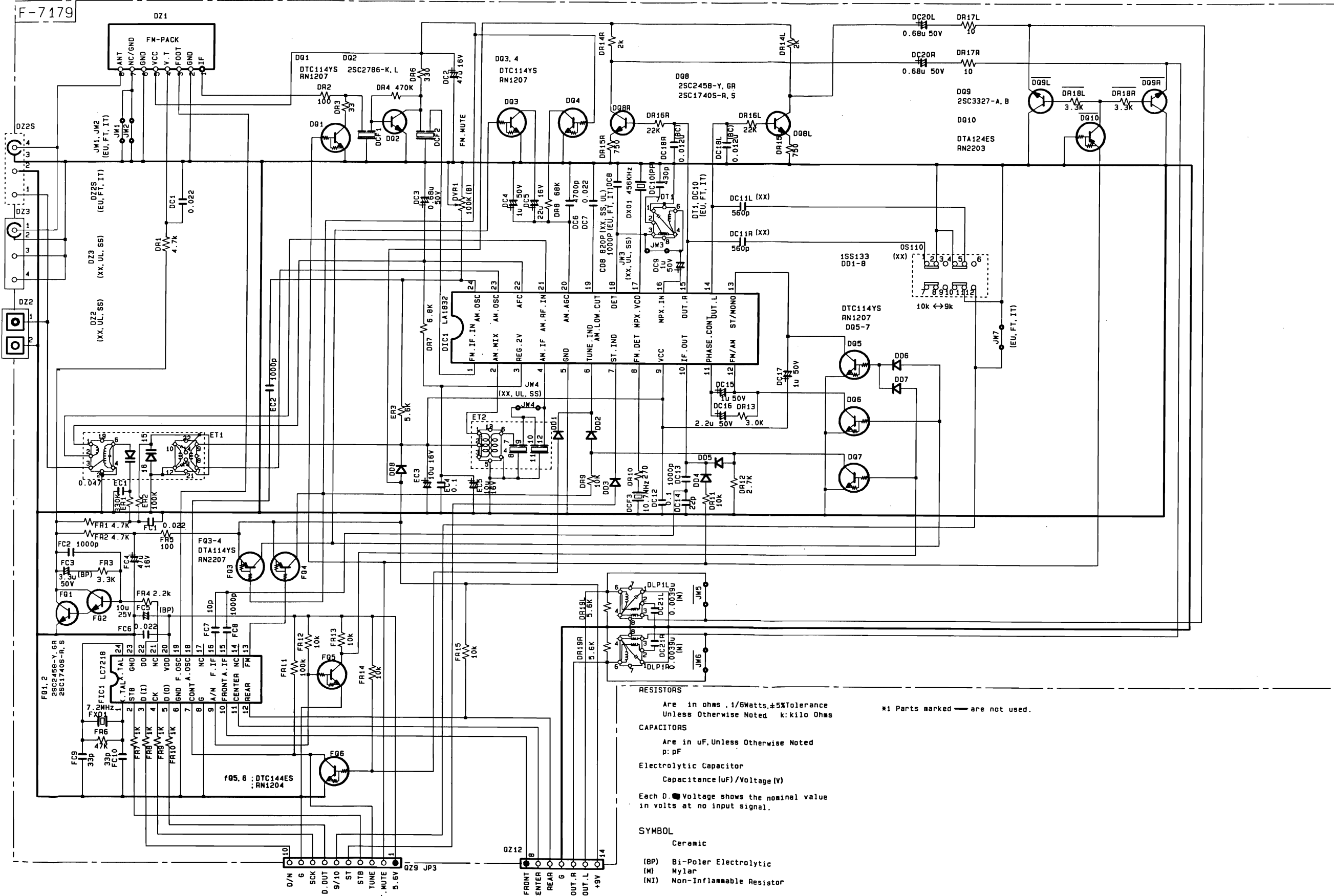

4. ADJUSTMENT / 調整方法

3-1. DOLBY PROLOGIC SURROUND LEVEL ADJUSTMENT (Fig. 1) / ドルビー・プロロジック・サラウンド・レベル調整 (Fig. 1)

NOTE / (条件書き) : (Board Number : F - 7167) Fig. 1 F - 7167

1. Input Selector Switch " CD "
2. Surround Mode Switch " DOLBY PROLOGIC "
3. " SOURCE DIRECT " Switch " Off "
4. And setting S - Signal Generator and A.C. Millivolt Meter.

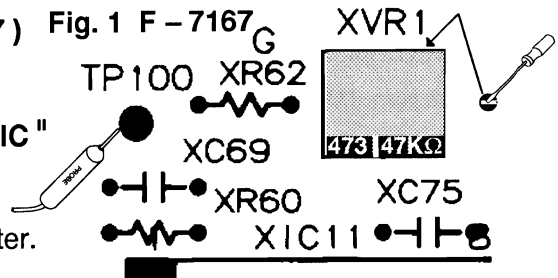

1. Remove the Bonnet.
2. Setting are shown in " NOTE " and the " POWER (STANDBY) " key switch pushed On.
3. Put the feed S - signal (Both L-ch. and R-ch. 212mVr.m.s. at 1kHz *out-phase*) to " CD " input terminals.
4. Put the high impedance probe between " TP100 " and GND. .
5. Adjust " xVR1 " to get the 600mVr.m.s. .
NOTICE : *out-phase* is " COSINE WAVE " and " SINE WAVE " signals on each channels.

1. ボンネットを外す。(小ネジ9本/側面並び背面に各3本)
2. 用意(準備)は"条件書き"参照、電源スイッチ投入。
3. "CD"入力端子にS-signalを加える。
(S - signal に就いては左側括弧内を参照下さい。)
4. "TP100"とGND.間にハイ・インピーダンス・プローブを接続する。
5. "xVR1"を600mVr.m.s.に調整する。
告知 : *out-phase*とは各々のチャンネルに余弦波及び、正弦波が載っている信号の事です。

3-2. TUNER SECTION ADJUSTMENT (For receiver only!!) (Board Number : F - 7179) (For the other markets than Japanese!!)

3-2-1. F.M. STEREOPHONIC DISTORTION ADJUSTMENT (Fig. 2 and Fig. 4)

- NOTE :
1. Input Selector Switch " TUNER "
 2. Tuning Band Selector Switch " FM "
 3. Tuning Mode Switch " TUNING AUTO "
 4. SOURCE DIRECT " On "
 5. And setting F.M. STEREOPHONIC Signal Generator, A.C. Milli-Volt & Distortion Meter and Wave Scope.

Fig. 2

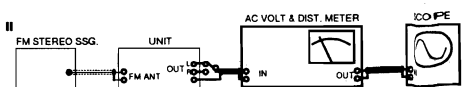

(Connections of F.M. Tuning Test)

1. Remove the Bonnet.
2. Connections are shown in " Fig. 2 " and the " POWER (STANDBY) " key switch pushed On.
3. Put the feed radio frequency signal of stereophonic full modulation on Left channel only at 1kHz carried by frequency modulation wave of 65dBf at 98MHz from F.M. Stereophonic Signal Generator to " FM Antenna terminal " in the model.
4. Adjust the ferrite core in Intermediate Frequency Transformer on " F.M. Front-end (Pack) " to get minimum noise and distortion level on Left channel of REC (OUT) terminal at TAPE 1, TAPE 2 / MONITOR or VIDEO.

3-2-2. F.M. MUTING LEVEL ADJUSTMENT (Fig. 2 and Fig. 4)

NOTE : 1. Input Selector Switch " **TUNER** " 2. Tuning Band Selector Switch " **FM** "
 3. Tuning Mode Switch " **TUNING AUTO** " 4. SOURCE DIRECT " **On** "
 5. And setting F.M. STEREOPHONIC Signal Generator, A.C. Milli-Volt & Distortion Meter and Wave Scope.

1. Remove the Bonnet.
 2. Connections are shown in " **Fig. 2** " (before the page : **13** / section number : **3-2-1**) and the " **POWER (STANDBY)** " key switch pushed On.
 3. Put the feed radio frequency signal of monophonic full modulation at 1kHz carried by frequency modulation wave at **98MHz** from F.M. Stereophonic Signal Generator to " **FM Antenna terminal** " in the model.
 4. Adjust the " **dVR1** " to get, at the Time radio frequency signal carried by frequency modulation wave at 25dBf, signals on both channels output terminals at 1kHz and each the time and radio frequency signal carried by frequency modulation wave at 24dBf, non signals on both channels output terminals at 1kHz.
- * *Output terminals are REC (OUT) terminal at TAPE 1, TAPE 2 / MONITOR or VIDEO.

3-2-3. A.M. INTERMEDIATE FREQUENCY TRANSFORMER ADJUSTMENT (Fig. 3 and Fig. 4)

NOTE : 1. Input Selector Switch " **TUNER** "
 2. Tuning Band Selector Switch " **AM** "
 3. Tuning Mode Switch " **TUNING AUTO** "
 4. SOURCE DIRECT " **On** "
 5. And setting A.M. Signal Generator, A.C. Milli-Volt Meter and Wave Scope.

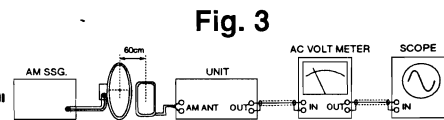

1. Remove the Bonnet.
 2. Connections are shown in " **Fig. 3** " and the " **POWER (STANDBY)** " key switch pushed On.
 3. Put the feed radio frequency signal of monophonic full modulation at 400Hz carried by amplitude modulation wave of **55dBm** at **1000kHz** or **999kHz** from A.M. Monophonic Signal Generator to " **AM Antenna terminal** " in the model.
 4. Adjust the " **eT2** " to get, at the maximum output signal level on output terminals .
- * *Output terminals are REC (OUT) terminal at TAPE 1, TAPE 2 / MONITOR or VIDEO. * *

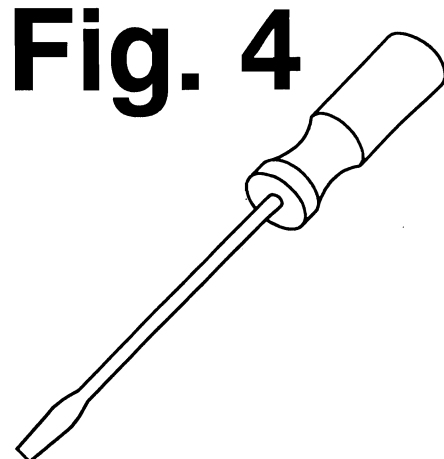
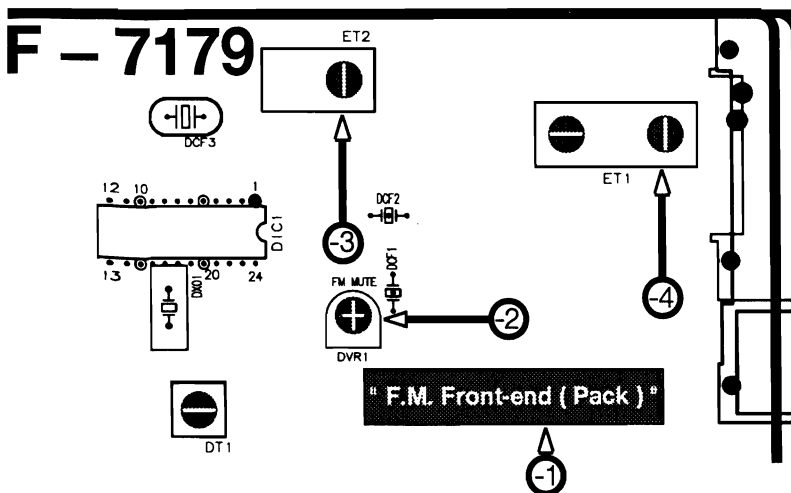

RZ-8100AV RZ-8150AV

3-2-4. A.M. TRACKING LEVEL ADJUSTMENT (Fig. 3 and Fig. 4) [Seni-Adjustment Free !!]

NOTE : 1. Input Selector Switch "TUNER " 2. Tuning Band Selector Switch " AM " 3. Tuning Mode Switch " TUNING AUTO " 4. SOURCE DIRECT " On " 5. And setting A.M. Signal Generator, A.C. Milli-Volt Meter and Wave Scope.

Must be A.M. TRACKING LEVEL ADJUSTMENT if out of A.M. Usable Sensitivity in standard specifications at model code " R2910 ".

It is the signal to noise ratio more than 20dB on output terminal at put the feed radio frequency signal of monophonic full modulation at 400Hz carried by amplitude modulation wave of **64dBm** at **1000kHz** or **999kHz** from A.M. Monophonic Signal Generator to " **AM Antenna terminal** ".

1. Remove the Bonnet.
2. Connections are shown in " Fig. 3 " (before the page : 13 / section number : 3-2-3) and the " **POWER (STANDBY)** " key switch pushed On.
3. Put the feed radio frequency signal of monophonic full modulation at 400Hz carried by amplitude modulation wave of **55dBm** to **60dBm** at **600kHz** or **603kHz** from A.M. Monophonic Signal Generator to " **AM Antenna terminal** " in the model.
4. Adjust the " **ferrite core near the antenna terminal of eT2** " to get, at the maximum output signal level on output terminals .
* *Output terminals are REC (OUT) terminal at TAPE 1, TAPE 2 / MONITOR or VIDEO.* *

5. INTERIOR BLOCK DIAGRAM & TERMINAL FUNCTION OF ICs / 使用ICの内部ブロック図及び、端子機能

* *(For receiver only!! * For the other markets than Japanese!!) * *

● LA1832 < FM / AM RF MPX >

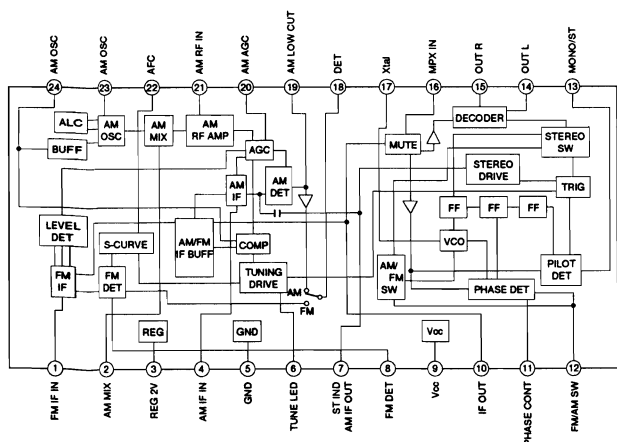

● LC7218

<PLL FREQUENCY SYNTHESIZER>

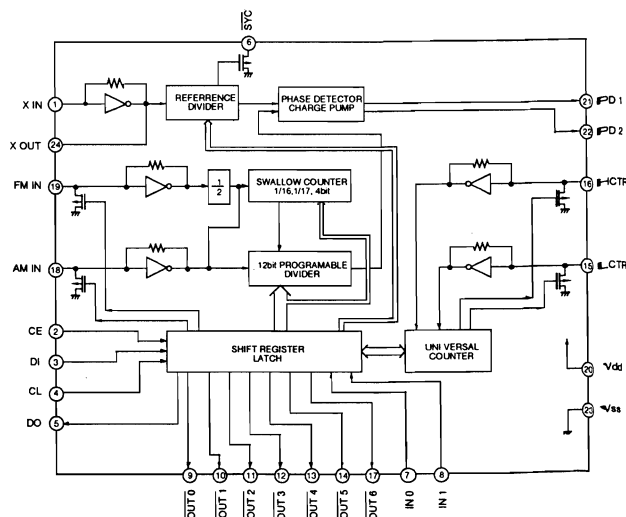

* *(For all models !! * For World wide markets !!) * *

● TC9184P

< TONE CONTROL CIRCUIT >

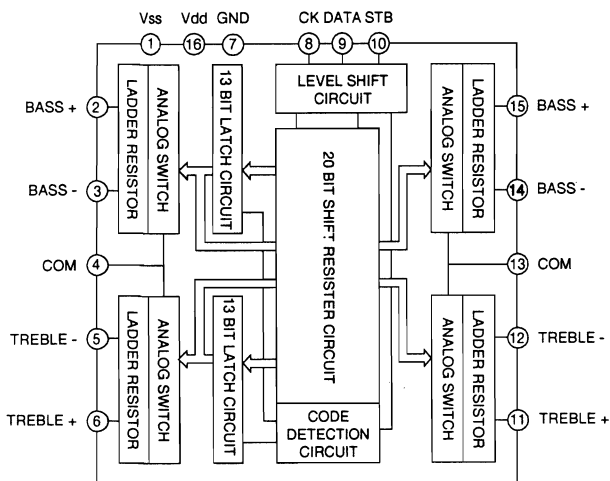

● LB1641

< MOTOR DRIVE CIRCUIT >

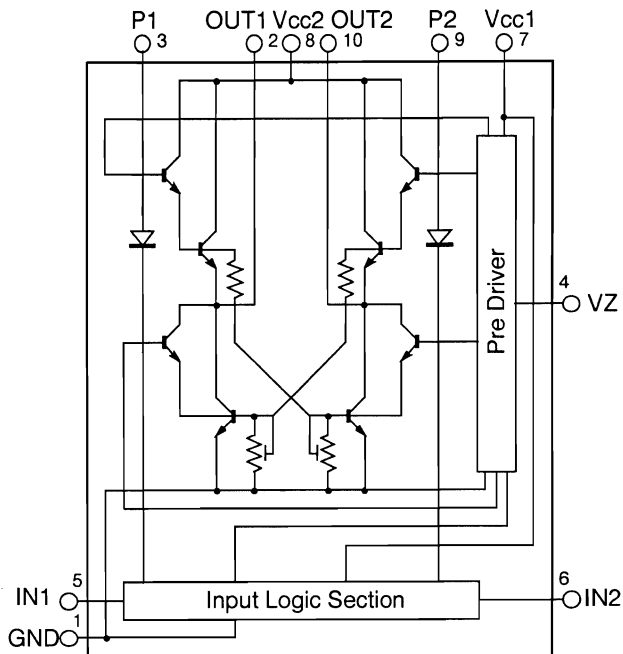

● 4558D, 4558L & 4558DX

< DUAL OPERATIONAL AMPLIFIERS >

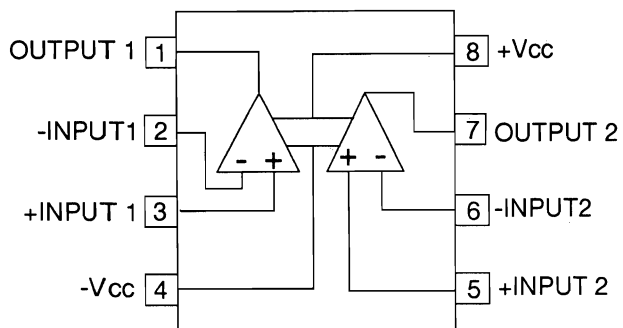

● 4066

< QUAD ANALOG SWITCHES >

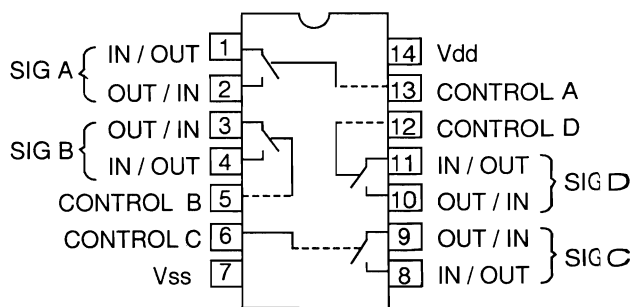

● TC9213P

< ATTENUATORS CIRCUIT >

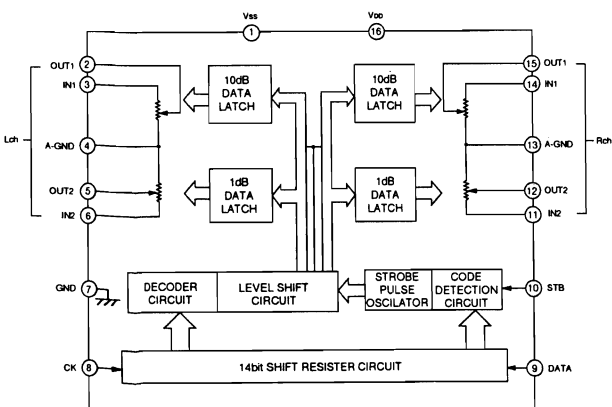

● **LV1001MA < DOLBY SURROUND PASSIVE DECODER >**

BLOCK DIAGRAM

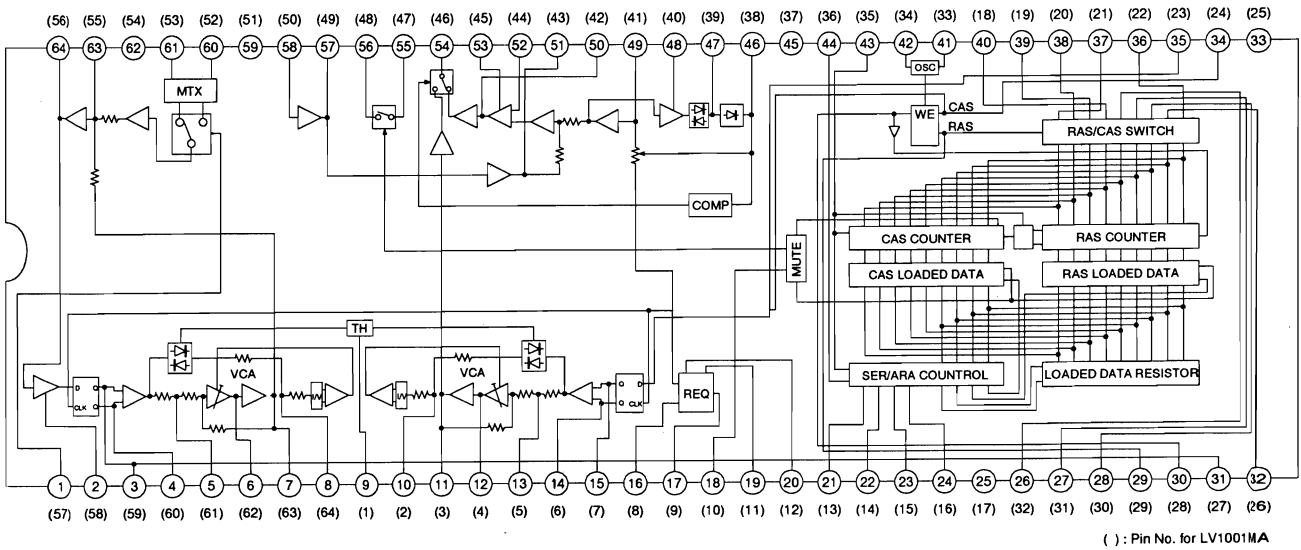

TERMINAL FUNCTION

Pin No.	Description
1(57)	Delay input signal mode select switch (L+R / L-R)
2(58)	Filter for supply voltage on comparator
3, 15(7, 59)	Input filter for rectifier
4, 14(6, 60)	Input filter for rectifier
5, 13(5, 61)	Capacitor for pre-emphasis
6, 12(4, 62)	Capacitor for sliding band filter
7(63)	Capacitor for sliding band filter and local decoder output
8, 10(2, 64)	Capacitor for smoothing of rectifier output
9(1)	De-couple capacitor for threshold voltage
11(3)	Capacitor for sliding band filter and Delayed output
16(8)	Reference voltage
17(9)	Reference voltage
18(10)	Mute control
19(11)	Vcc
20(12)	Output for Vdd
21(13)	Clock input for serial input, data input for parallel input mode
22(14)	Data input for serial input, data for parallel input mode
23(15)	Column address selection for serial input, data input for parallel input mode
24(16)	Row address selection for serial input, data input for parallel input mode
25(17)	Vdd

Pin No.	Description
26 to 40	Connection to memory device
18 to 32	Connection to memory device
33(25)	Vss
41(33)	X'tal resonator for oscillator
42(34)	X'tal resonator for oscillator
43(35)	Long or short mode selection
44(36)	Serial or Parallel mode selection
45(37)	For test mode
46(38)	Smoothing for NR rectifier
47(39)	Smoothing for NR rectifier
48(40)	Capacitor for weighting on side chain path
49(41)	Input for variable resistor
50(42)	NR output
51(43)	7kHz low pass filter output
52(44)	Input for NR
53(45)	Capacitor for de-couple on NR
54(46)	Delay output for NR output
55(47)	Input for mute circuit
56(48)	Output for mute circuit
57(49)	Output for 7kHz low pass filter
58(50)	Input for 7kHz low pass filter
59(51)	GND
60(52)	Input for right channel
61(53)	Input for left channel
62(54)	Capacitor for de-couple on Fixed matrix output
63(55)	Noise shaping and delay input
64(56)	Noise shaping output

● LM33256G – 12

<<DYNAMIC RANDOM ACCESS MEMORY>>

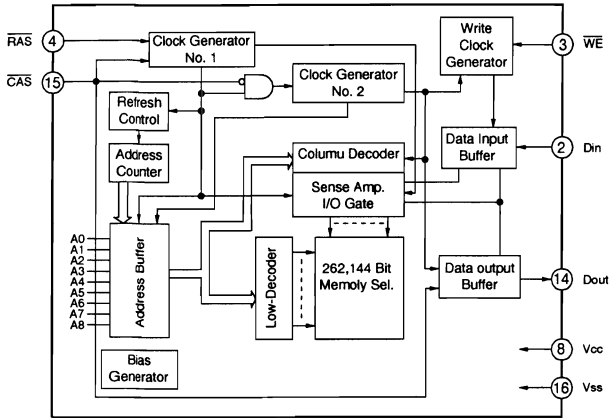

Terminal Function

Pin No.	Symbol	Pin Name
2	Din	Data input
3	WE	Write Enable
4	RAS	Row address strobe
8	Vcc	Power supply (+5V)
14	Dout	Data output
15	CAS	Column address strobe
16	Vss	Power supply (0V)
1, 5, 6, 7, 9 ~ 13	A0 ~ A8	Address input

● LA2780N

<<PLL FREQUENCY SYNTHESIZER>>

Block Diagram

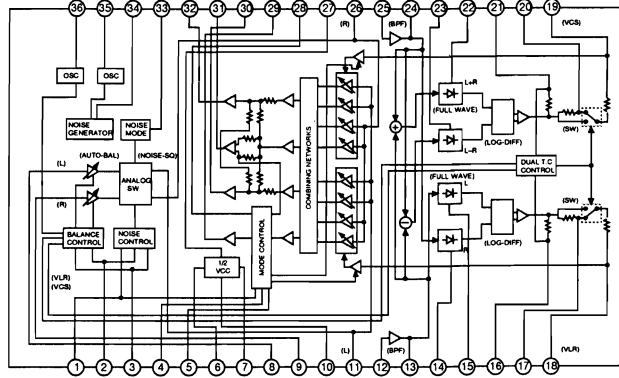

Explanation of Pin Function

1	Switch for 3 Channel Logic/Pro Logic/Noise Sequencer	19	VCS Smoothing Capacitor for Dual Time Constant
2	Noise Sequencer LSB	20	VCS Smoothing Capacitor for Dual Time Constant
3	Noise Sequencer MSB/Auto Balance On/Off Switch	21	VCS Smoothing Capacitor for Dual Time Constant Threshold
4	Center Mode Control Switch 1	22	L - R Smoothing Capacitor for Full Wave Rectifier
5	Center Mode Control Switch 2	23	L - R Smoothing Capacitor for Full Wave Rectifier
6	VREF	24	RT Buffer Output for Full Wave Rectifier
7	AC GND	25	RT Buffer Input for Full Wave Rectifier
8	LT Input	26	RT Output (Noise Sequencer/Auto Balance Output)
9	RT Input	27	VCC
10	GND	28	Capacitor for Center Mode Control
11	LT Output (Noise Sequencer/Auto Balance Output)	29	S Channel Output
12	LT Buffer Input for Full Wave Rectifier	30	R Channel Output
13	LT Buffer Output for Full Wave Rectifier	31	C Channel Output
14	R Smoothing Capacitor for Full Wave Rectifier	32	L Channel Output
15	L Smoothing Capacitor for Full Wave Rectifier	33	Pseudo Random Noise Input
16	VLR Smoothing Capacitor for Dual Time Constant Threshold	34	Pseudo Random Noise Output
17	VLR Smoothing Capacitor for Dual Time Constant	35	Oscillation Capacitor for Pseudo Random Noise Generator
18	VLR Smoothing Capacitor for Dual Time Constant	36	Oscillation Capacitor for Auto Balance

Notes on using this IC

- Switching pop noise
Switching pop noise occurs at output channels, front side in center mode control, and surround side in 3 channel logic control. Since these noise is marked, please add mute circuits at output stages in mode control.
- Measurement for matrix rejection
Measure matrix rejection in wide mode.
- Control pins for auto balance
*Setting pin2
Pin2 is set to "H" when auto balance is activated. In noise sequencer mode, refer noise sequencer setting.
*Setting pin3
Pin3 is used as auto balance on mode in "H" and stop mode in "L". In auto balance stop mode, balance adjustment circuit hold in the condition in which left and right channel are set to the same balance (not adjusted condition).

● TC9162N

<<COMPLEX ANALOG MULTIPLEX>>

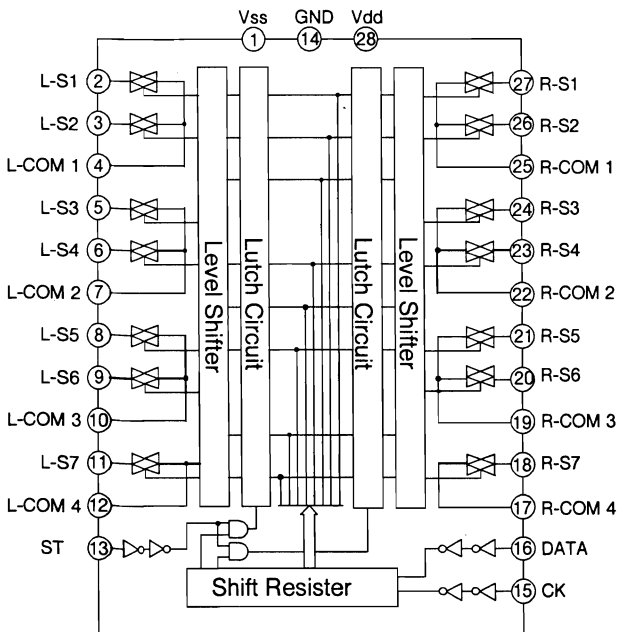

Mode Control Map

Mode	Pin1	Pin2	Pin3	Pin4	Pin5
Normal	Open	H	X	L	L
Phantom	Open	H	X	H	L
Wide	Open	H	X	L	H
3 Channel Logic	H	H	X	X	X
Auto Balance On	X	H	H	X	X
Auto Balance Off	X	H	L	X	X
Noise Sequencer L Channel Output	L	L	L	X	X
Noise Sequencer C Channel Output	L	H	L	X	X
Noise Sequencer R Channel Output	L	L	H	X	X
Noise Sequencer S Channel Output	L	H	H	X	X
Pro Logic Off Mode	H	H	X	H	H

RZ-8100AV**RZ-8150AV****AV-7100****AV-7150****AV-7700**

● **TMP47C1270AN – H221 < MICRO PROCESSING UNIT >**

Pin No.	Pin Name	I/O	Function
1	Vf		FL POWER SUPPLY
2 ~ 13	S0 ~ S11	O	FL SEGMENT OUTPUT
14	K00	I	HEAD PHONE INPUT
15	K01	I	BACK UP VOLTAGE INPUT
16	K02	I	FREQUENCY COUNT (TUNED)
17	K03	I	KEY INPUT DIODE
18	TEST		GND
19 ~ 20	XIN/OUT		QUARTZ OSCILLATOR (6MHz)
21	RESET		RESET SIGNAL INPUT
22	HOLD		HOLD SIGNAL INPUT
23	PWM	O	PROTECTOR OUTPUT
24 ~ 27	K1 ~ K4	I	KEY INPUT
28	SSB PUT	O	SSB OUT
29	P. OUT	O	POWER ON/OFF SIGNAL
30	T. MUTE	O	TUNER MUTE SIGNAL
31	DECK P. O.	O	DECK PAUSE SIGNAL OUT
32	GND		

Pin No.	Pin Name	I/O	Function
33	UP	O	VOLUME UP
34	DN	O	VOLUME DOWN
35	LED	O	VOLUME LED
36	S. MUTE	O	SIGNAL MUTE
37	A	O	TC4028 A
38	B	O	TC4028 B
39	C	O	TC4028 C
40	STB	O	LC7218 STB
41	REM	I	REMOTE SIGNAL INPUT
42	STEREO	I	STEREO ON/OFF
43	9/10	I	9k/10k
44	CK EN	O	CLOCK ENABLE OUT
45	DATA IN	I	SERIAL DATA INPUT
46	DATA OUT	O	SERIAL DATA OUTPUT
47	CK	O	SERIAL CLOCK OUTPUT
48 ~ 59	G15 ~ G4	O	FL DIGIT OUTPUT
60 ~ 63	S15 ~ S12	O	FL SEGMENT OUTPUT
64	Vdd		5V

• **KEY MATRIX**

S	TACT SWITCH				DIODE(K03)	
	K0 IN1	K1 IN2	K2 IN3	K3 IN4	USED(H)	NOT USED(L)
S00	THEATER	CD	10KEY 3	PRESET SCAN		
S01	HALL	VIDEO	10KEY 2	CHARACTER		
S02	SOUND PARAM.	LD	10KEY 1	AUTO / MANU		
S03	MULTI FUN. LEFT	TAPE-2 / MON	10KEY 8	CLEAR		
S04	MULTI FUN. UP	TONE	10KEY 7	BAND		
S05	MULTI FUN. DOWN	LOUDNESS	10KEY 6	MEMORY		
S06	PRO-LOGIC	TUNER	10KEY 4	ENTER		
S07	DOVE	TAPE-1	10KEY 5	F. DIRECT		
S08	MULTI FUN. RIGHT	SOURCE DIRECT	KARAOKE	POWER		
S09	NATURAL	TUNING DOWN	10KEY 0 / 10		LW USED	LW NOT USED
S10	2 CH STEREO	PHONO	10KEY 9		D. LOW	D. HIGH
S11		TUNING UP	INDEX STATION M.		JAPAN	EXPORT

● TC9163P

<COMPLEX ANALOG MULTIPLEX>

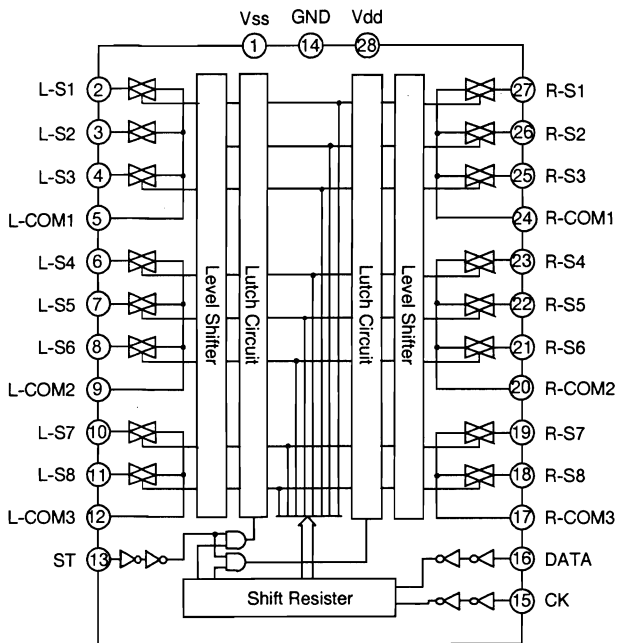

● TC9163P

<COMPLEX ANALOG MULTIPLEX>

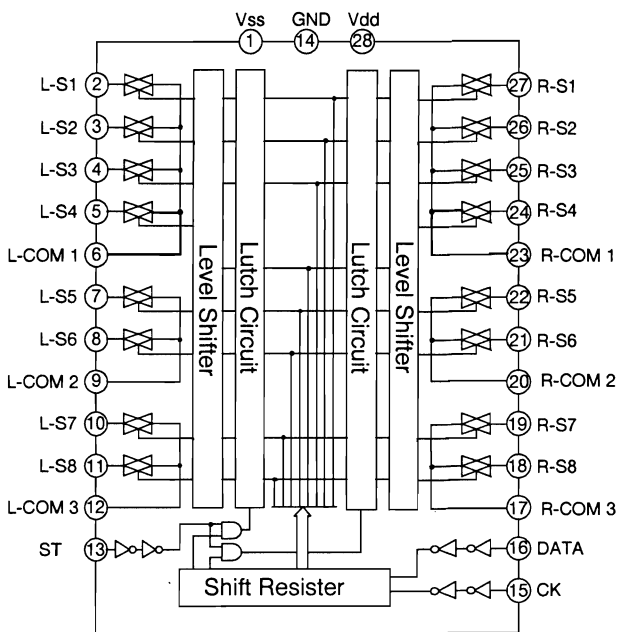

● STK401 - 40 & STK401 - 330

<HYBRID MAIN AMPLIFIER CIRCUIT>

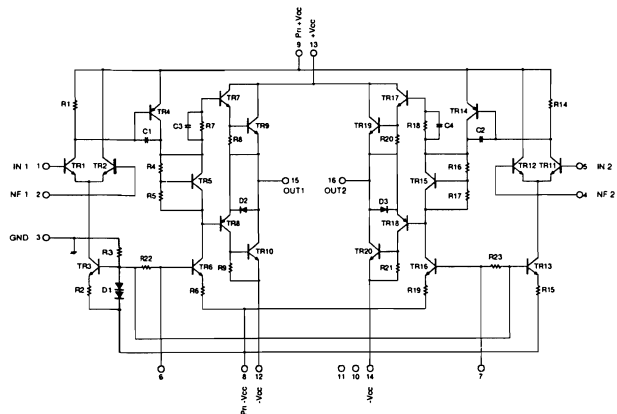

● 4028PB <BCD - DECIMAL DECODER>

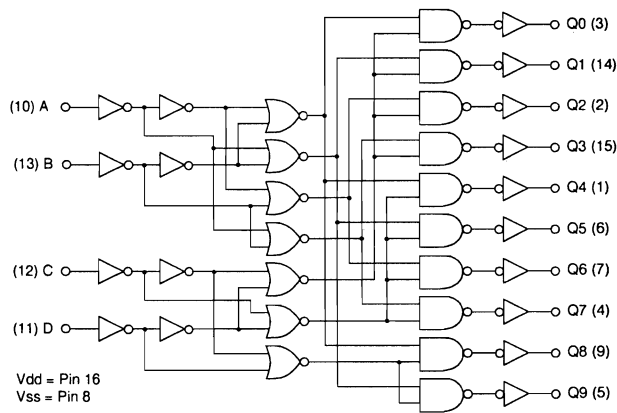

● TC7317P <PROTECTOR CIRCUIT>

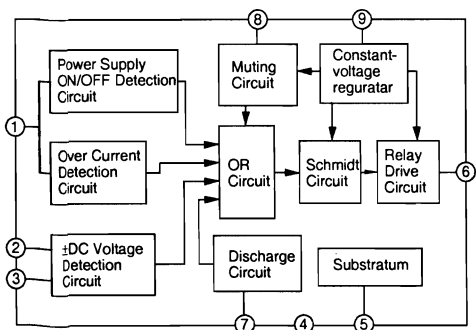

INPUT				OUTPUT									
D	C	B	A	Q9	Q8	Q7	Q6	Q5	Q4	Q3	Q2	Q1	Q0
L	L	L	L	L	L	L	L	L	L	L	L	L	H
L	L	L	H	L	L	L	L	L	L	L	L	H	L
L	L	H	L	L	L	L	L	L	L	L	H	L	L
L	L	H	H	L	L	L	L	L	L	H	L	L	L
L	H	L	L	L	L	L	L	L	H	L	L	L	L
L	H	L	H	L	L	L	L	L	L	L	L	L	L
L	H	H	L	L	L	L	L	L	L	L	L	L	L
L	H	H	H	L	L	L	L	L	L	L	L	L	L
H	L	L	L	L	H	L	L	L	L	L	L	L	L
H	L	L	H	L	H	L	L	L	L	L	L	L	L
H	L	H	L	L	L	L	L	L	L	L	L	L	L
H	L	H	H	L	L	L	L	L	L	L	L	L	L
H	H	L	L	L	L	L	L	L	L	L	L	L	L
H	H	L	H	L	L	L	L	L	L	L	L	L	L
H	H	H	L	L	L	L	L	L	L	L	L	L	L
H	H	H	H	L	L	L	L	L	L	L	L	L	L

● JM2245D < VIDEO SELECTOR >

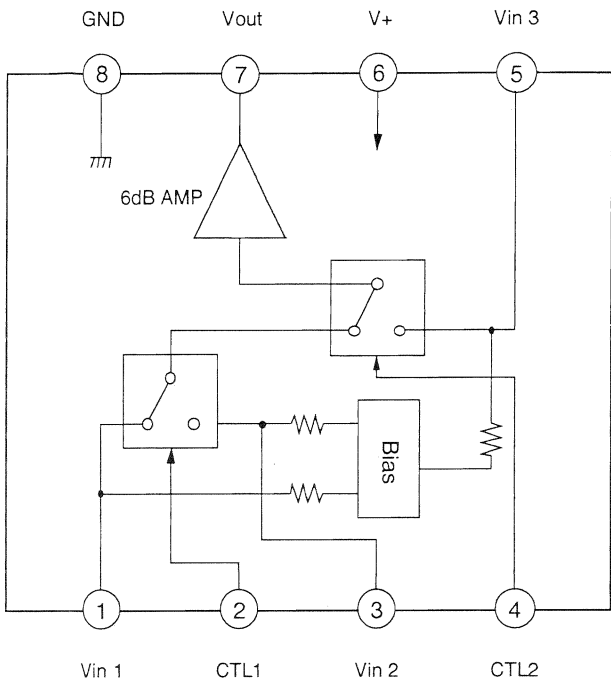

CTL1	CTL2	Vout
L	L	Vin 1
H	L	Vin 2
L/H	H	Vin 3

● 74HC123AP < DUAL MONOSTABLE MULTIVIBRATOR >

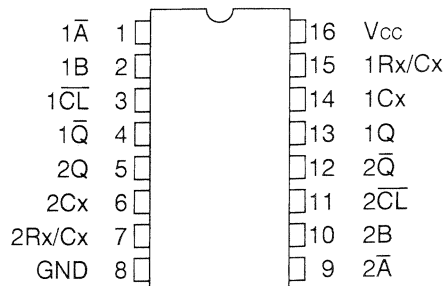

(TOP VIEW)

INPUT			OUTPUT		NOTE
A	B	CL	Q	Q̄	
L	H	H	⌋	⌋	OUTPUT ENABLE
X	L	H	L	H	INHIBIT
H	X	H	L	H	INHIBIT
L	L	H	⌋	⌋	OUTPUT ENABLE
L	H	L	⌋	⌋	OUTPUT ENABLE
X	X	L	L	H	INHIBIT

X: Don't Care

6. PARTS LOCATION ON PRINTED CIRCUIT BOARD / プリント基板の部品配置図

● F-7166 < AUDIO CONTROL BOARD > (COMPONENT SIDE VIEW)

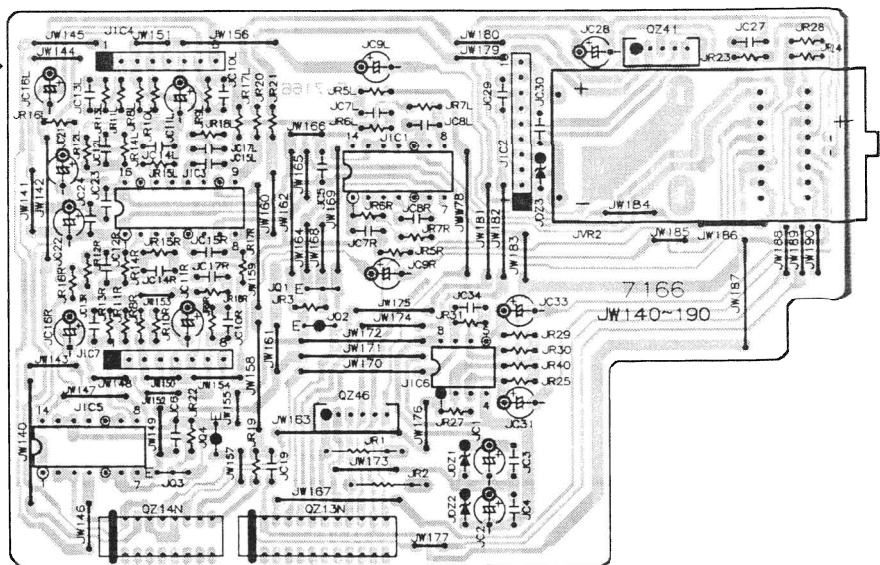

● F - 7167 < D.S.P. - SURROUND & VOICE CANCEL BOARD >
(COMPONENT SIDE VIEW)

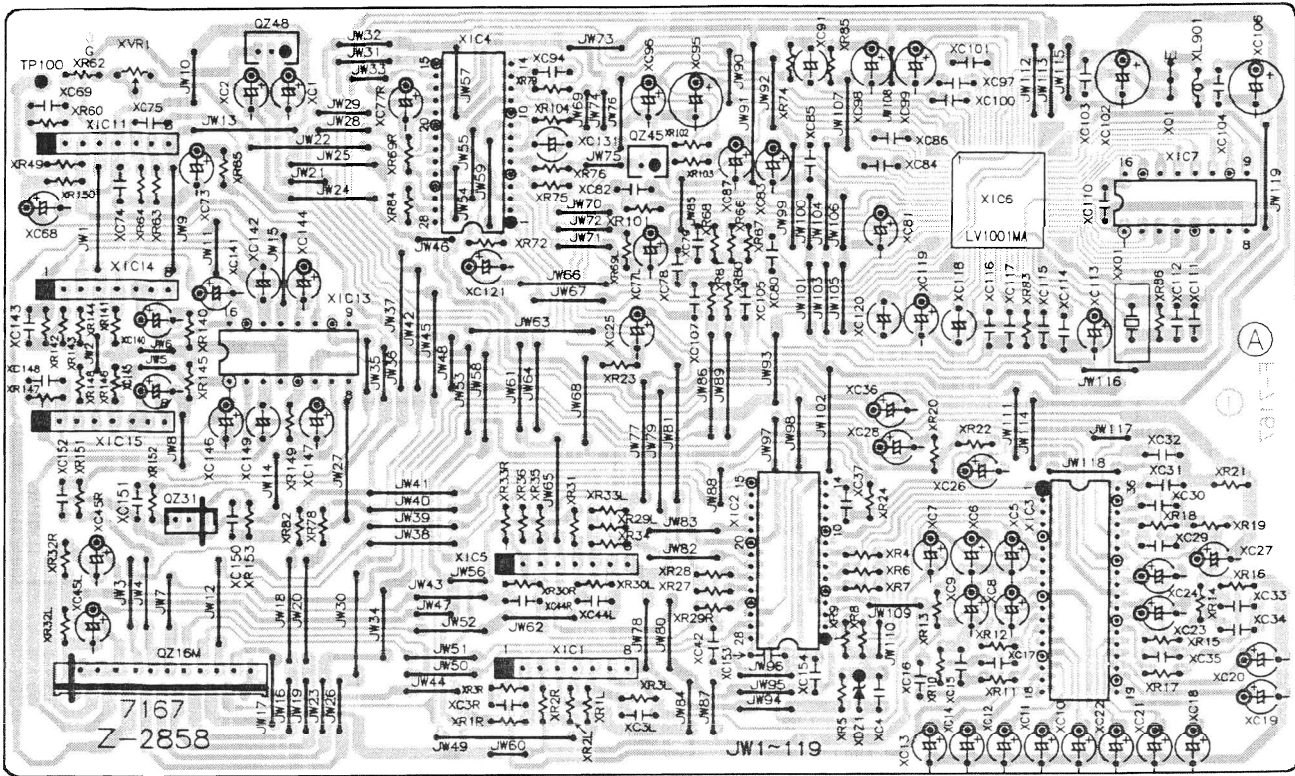

● F - 7168 < MICROPHONE AMPLIFIER BOARD > (COMPONENT SIDE VIEW)

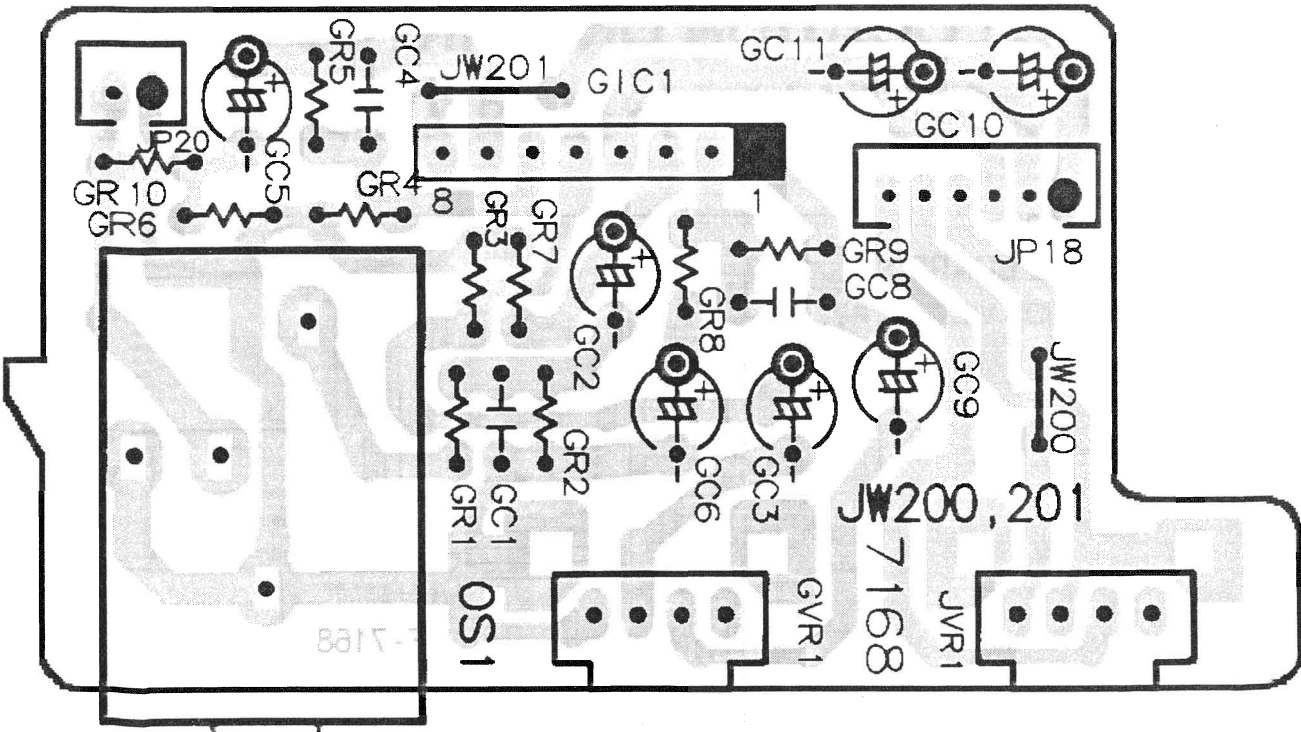

RZ-8100AV

RZ-8150AV

AV-7100

AV-7150

AV-7700

● F - 7169 < SYSTEM CONTROL & DISPLAY BOARD > (COMPONENT SIDE VIEW)

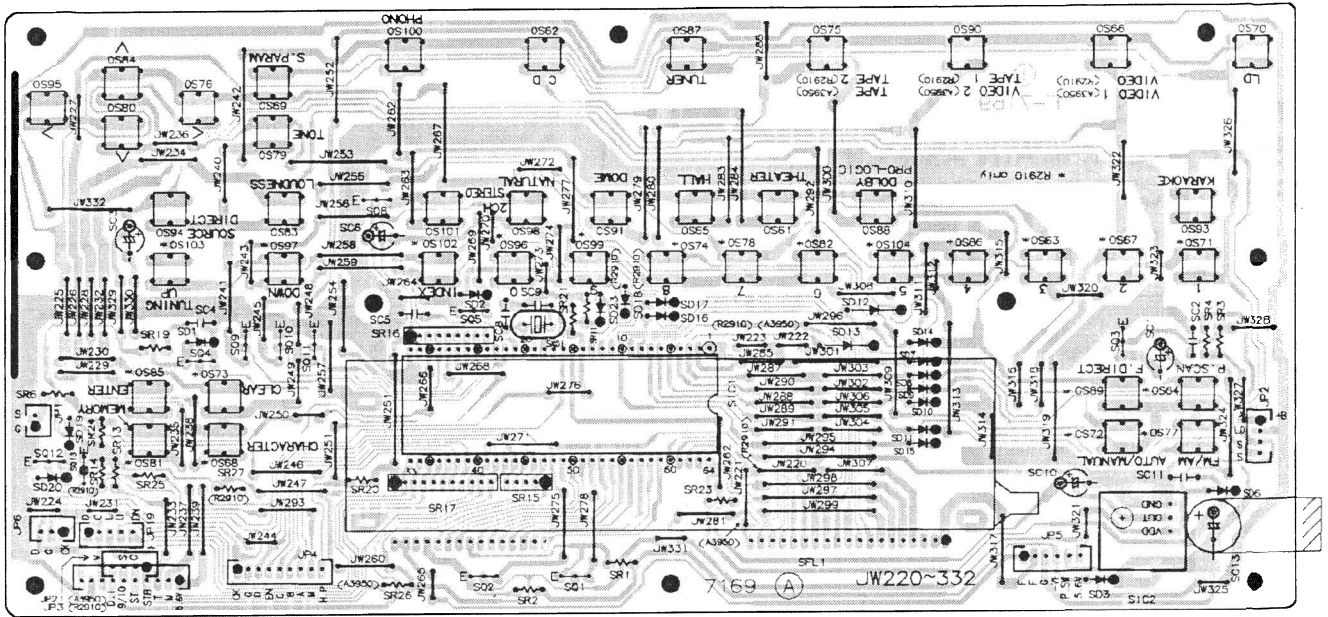

● F - 7170 < A.C. POWER CONTROL & LINE BOARD > (COMPONENT SIDE VIEW)

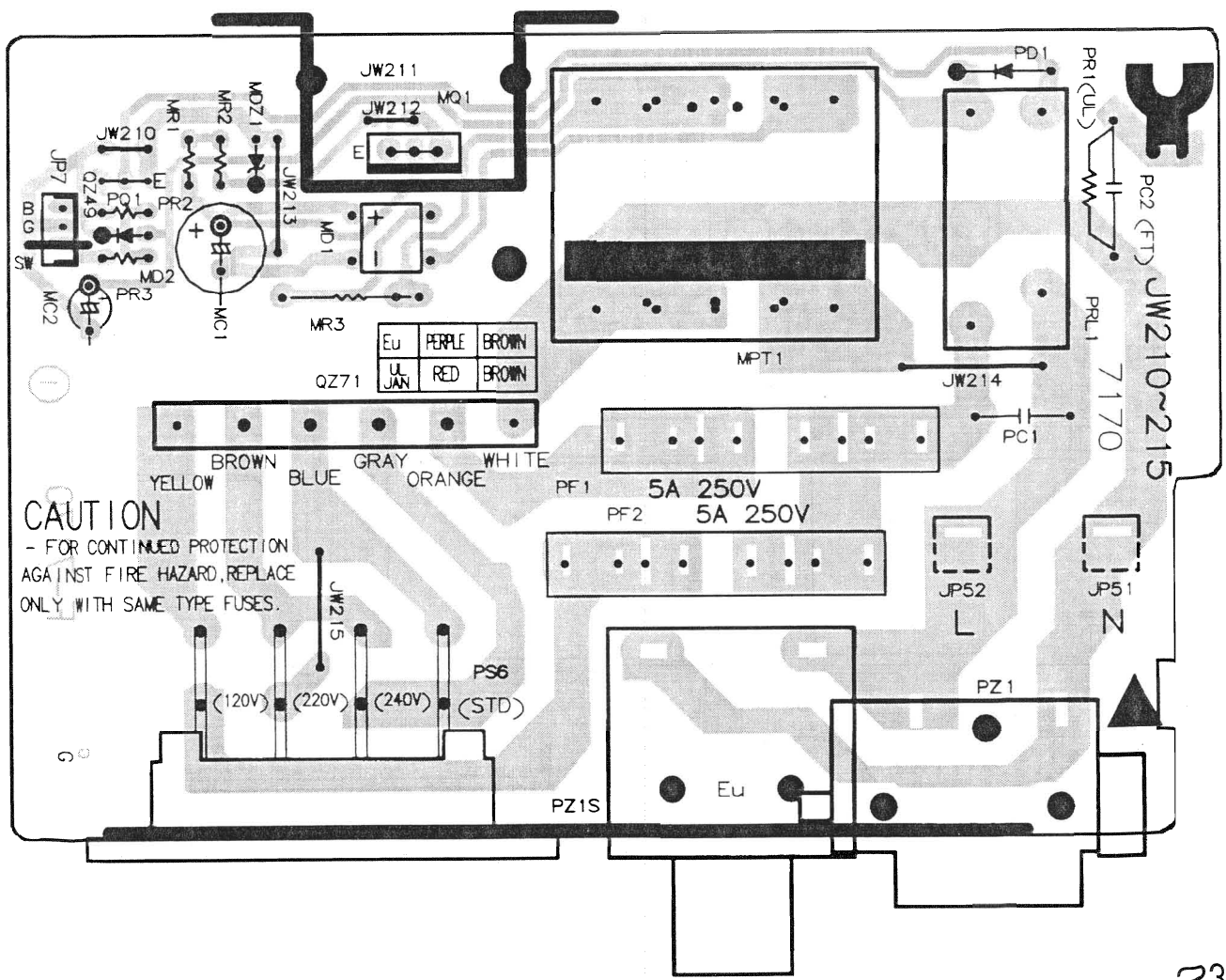

AV-7700

AV-7150

AV-7100

RZ-8150AV

RZ-8100AV

● F - 7171

◀ POWER KEY SWITCH BOARD ▶

(COMPONENT SIDE VIEW)

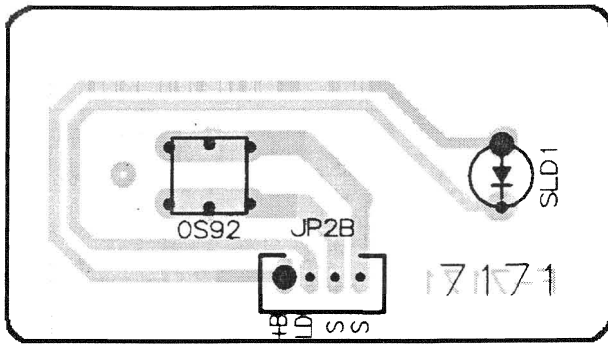

● F - 7173 ◀ MAIN BOARD (AUDIO SELECTOR, MAIN AMPLIFIER, PROTECTOR & POWER SUPPLY) ▶

(COMPONENT SIDE VIEW)

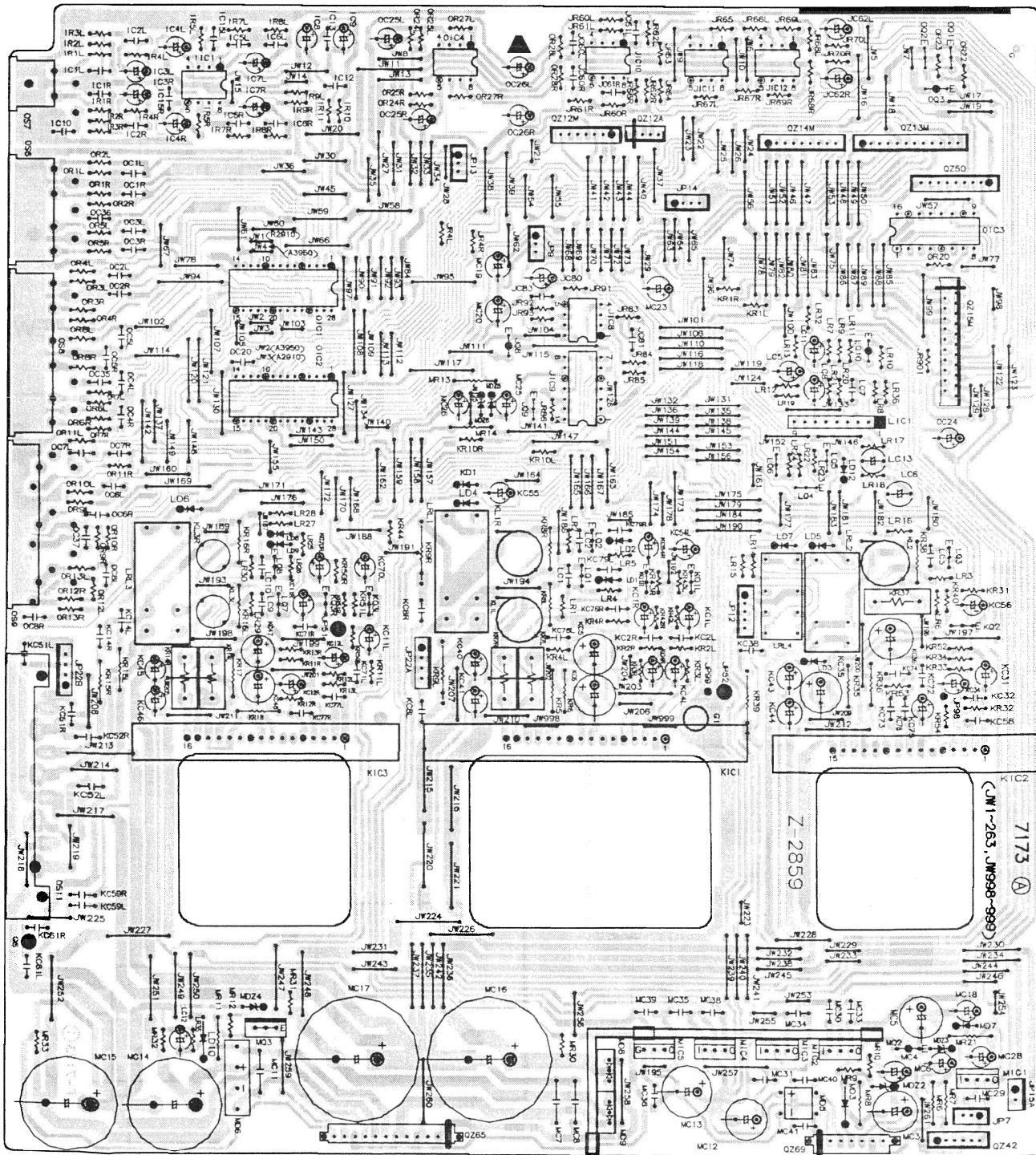

RZ-8100AV

RZ-8150AV

AV-7100

AV-7150

AV-7700

● F - 7174

◀ CENTER SPEAKER TERMINAL BOARD ▶
(COMPONENT SIDE VIEW)

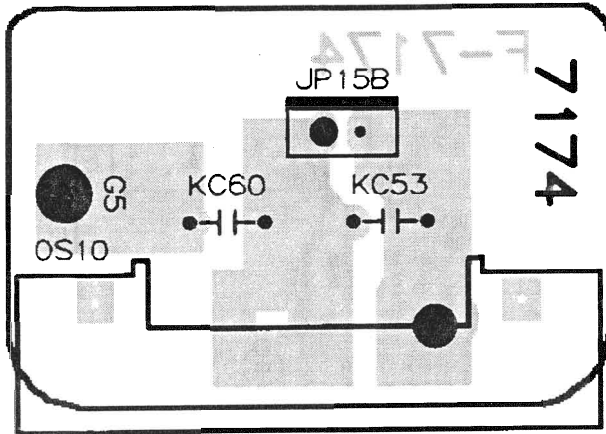

● F - 7175

◀ HEADPHONE JACK TERMINAL BOARD ▶
(COMPONENT SIDE VIEW)

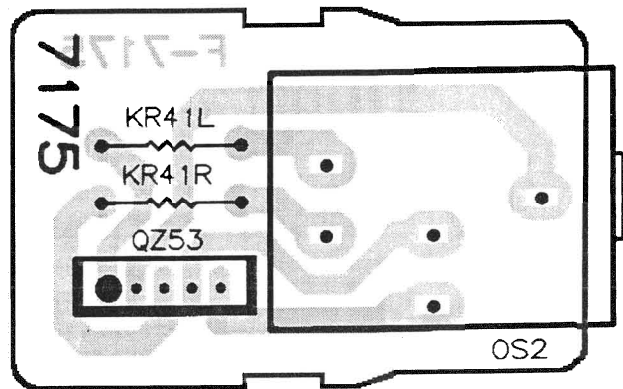

● F - 7176

◀ OUTPUT POWER SELECTOR BOARD ▶ (COMPONENT SIDE VIEW)

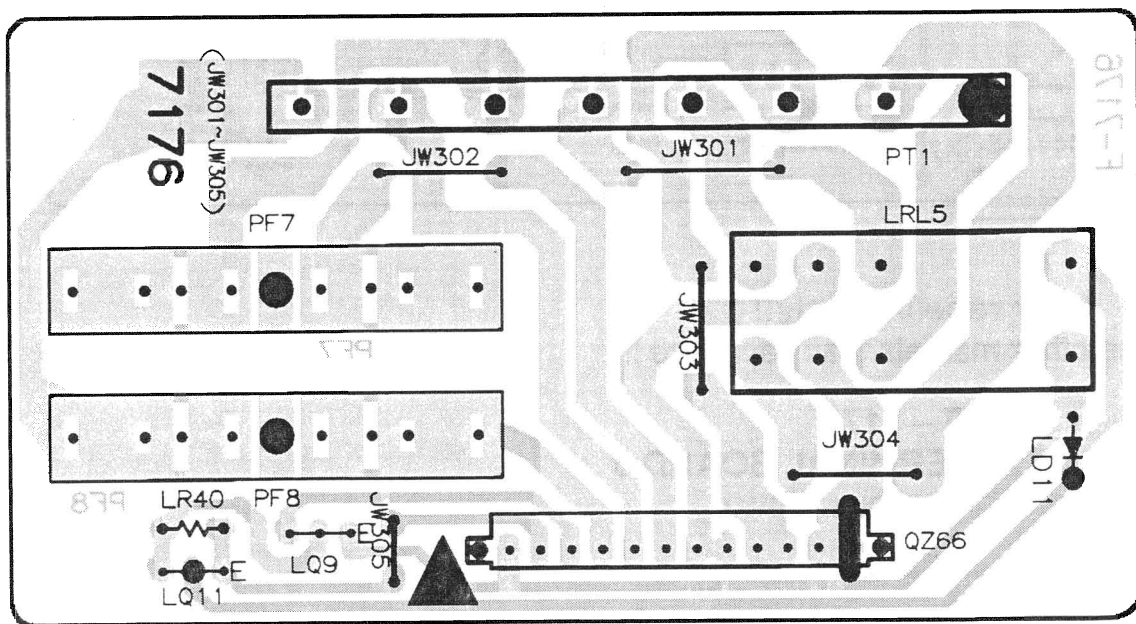

● F - 7177 ◀ SECONDARY FUSE BOARD ▶
(COMPONENT SIDE VIEW)

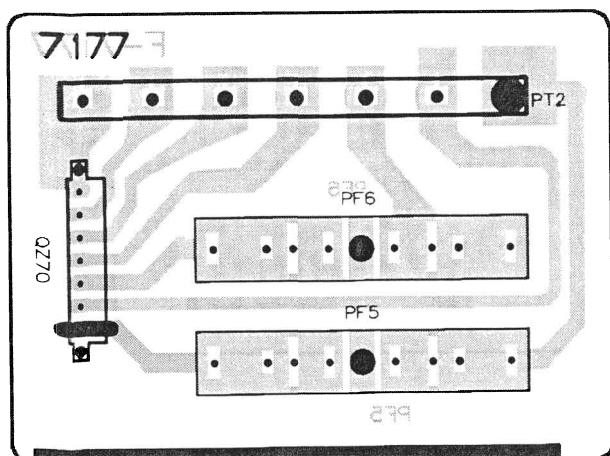

● F - 7178 ◀ VIDEO SELECTOR BOARD ▶
(COMPONENT SIDE VIEW)

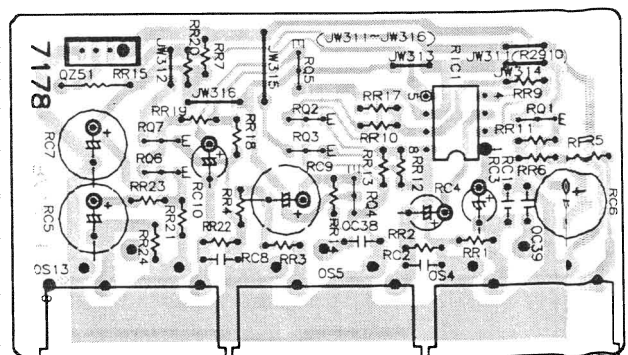

AV-7700

AV-7150

AV-7100

RZ-8150AV

RZ-8100AV

*(For receiver only!! * For the other markets than Japanese!!) *

● F - 7179 < MICROPHONE AMPLIFIER BOARD > (COMPONENT SIDE VIEW)

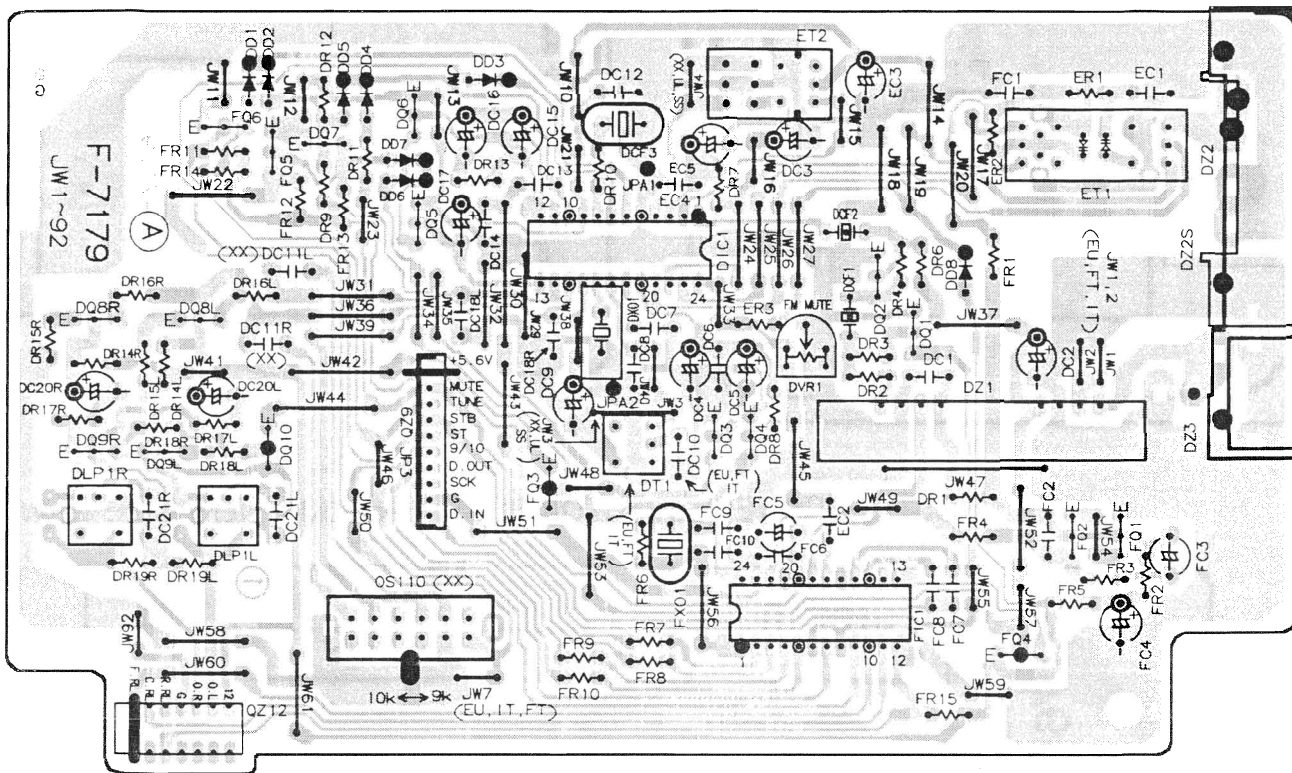

(For receiver only!!)

(For the other markets than Japanese !!)

● F - 7172

< BUS - LINE TERMINAL BOARD >

(COMPONENT SIDE VIEW)

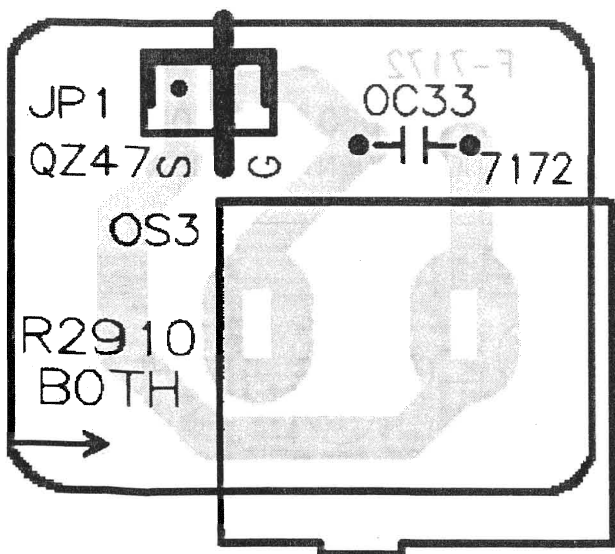

● F - 7211 < DE - BUG CIRCUIT BOARD >

(COMPONENT SIDE VIEW)

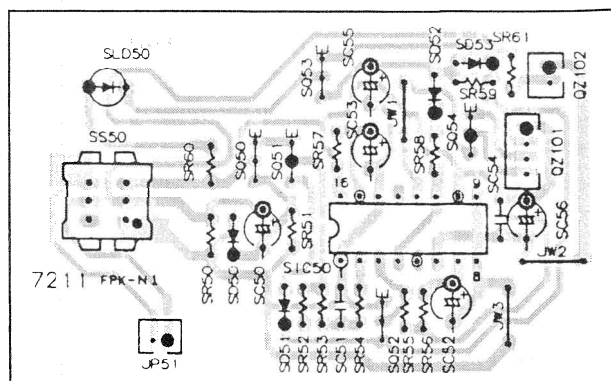

7. PARTS LIST OF PRINTED CIRCUIT BOARD ／プリント基板部品表

Notice for Parts

- Some printed circuit board are not supplied assembled. To separate these in this Service Manual, the stock numbers are not indicated for these boards. However, stock numbers for individual parts are indicated.
- Since some capacitors and resistors are omitted from parts lists in service manual, refer to the Common Parts List for capacitors and resistors, which was issued on June 1987.
- Abbreviations in this Parts List are as follows.

部品供給上の注意

- プリント基板の中には、アッセンブリー供給できないものがあります。基板番号の後にストック番号の付いていないものは、アッセンブリー供給できませんのでご注意ください。ただし、基板上の個々の部品については供給いたします。
- 部品表に記載されていない、抵抗・コンデンサーがあります。それらについては、1987年3月発行の新規標準抵抗・コンデンサーパーツ・リストを参照してください。
- このマニュアルには、略語が使用されており、それらについては略語表を参照してください。

Abbreviations List

A.C. : Array Capacitor	E.C. : Electrolytic Capacitor	A.R. : Array Resistor
C.C. : Ceramic Capacitor	E.L. : Low Leak Electrolytic Capacitor	C.R. : Carbon Resistor
C.T. : Ceramic Capacitor, Temperature Compensation	F.C. : Film Capacitor	Ce.R. : Cement Resistor
Chip.C. : Chip Capacitor	M.M.C. : Metalized Mylar Capacitor	Chip.R. : Chip Resistor
E.B. : Bi-Polar Electrolytic Capacitor	M.P. : Metalized Paper Capacitor	F.R. : Fusing Resistor
E.B.L. : Low Leak Bi-Polar Electrolytic Capacitor	P.C. : Polystyrene Capacitor	M.R. : Metal Film Resistor
	Ta.C. : Tantalum Capacitor	N.I.R. : Non-Inflammable Resistor
	SW. : Switch	S.R. : Solid Resistor
		S.V.R. : Semi Variable Resistor
		V.R. : Variable Resistor

* * (For amplifier only !! * Model Name : AV - 7100 , AV - 7150 , AV - 7700) * *

● F - 7166B AUDIO CONTROL BOARD

< Stock No. 01408700 ,5 > / 音声調整基板

Parts No. Stock No. Description

● TRANSISTOR

jQ1	46719900	DTC124ES
jQ2	46719800	DTA124ES
jQ3	46719900	DTC124ES
jQ4	46719800	DTA124ES

● IC

jIC1	07224800	TC4066BP
	or 46421000	μPD4066BC
	or 48063800	BU4066B
jIC2	48982600	LB1641
jIC3	49558900	TC9184P
jIC4	49439500	NJM4558L OPAMP
jIC5	07224800	TC4066BP

Parts No. Stock No. Description

or 46421000 μPD4066BC

or 48063800 BU4066B

jIC6 03607700 NJM4558D OPAMP

jIC7 49439500 NJM4558L OPAMP

● ZENER DIODE

jDZ1 49677900 MTZJ9.1A

or 49678000 MTZJ9.1B

jDZ2 49677900 MTZJ9.1A

or 49678000 MTZJ9.1B

jDZ3 49675800 MTZJ4.7A

or 49675900 MTZJ4.7B

△jR1 49852100 N.I.R 1/2W 100 Ω

△jR2 49852100 N.I.R 1/2W 100 Ω

jVR2 49957600 V.R. 100 KΩ (B) X 4 WITH LEAD.

△pF7 49593900 FUSE 125V 4A

AV-7700**AV-7150****AV-7100****● F - 7167B D.S.P. - SURROUND & VOICE CANCEL BOARD / サラウンド基板**

< Stock No. 01408800 >

Parts No. Stock No. Description

●TRANSISTOR

xQ1 46359801 2SC2001

●IC

xIC1 49439500 NJM4558L OPAMP

xIC2 49471900 TC9162N

xIC3 49915800 LA2780N

xIC4 49471900 TC9162N

xIC5 49439500 NJM4558L OPAMP

xIC6 49915900 LV1001MA

xIC7 49916000 LM33256G-12

or 49916200 LH21256-12

or 49963700 LC32256P-80

xIC11 49439500 NJM4558L OPAMP

xIC13 49440100 TC9213P

xIC14 49439500 NJM4558L OPAMP

xIC15 49439500 NJM4558L OPAMP

xXO1 49774600 QUARTZ ELEMENT HC-49/S 8MHz

●ZENER DIODE

xDZ1 49676400 MTZJ5.6A

or 49676500 MTZJ5.6B

xC84 49929300 F.C. 100V 150pF APS (P.P.)

xC101 49929300 F.C. 100V 150pF APS (P.P.)

xL901 48289400 INDUCTOR 10 μ H AXIAL FERRIxVR1 48079600 S.V.R. 47 k Ω (B)**● F - 7169B**

Parts No. Stock No. Description

sIC2 49550900 REMOTE CONTIROL RECEIVER SBX1610-52

●TRANSISTOR

sQ1, 2 48223100 DTC114TS

sQ3 to 5 46834300 DTC144ES

sQ8, 9 46719900 DTC124ES

sQ10,11 46719900 DTC124ES

sQ12 48217800 DTC114ES

sQ13 46719800 DTA124ES

●ICsIC1 49959100 **M. P. U.** TMP47C870N-H561Z

sXO1 49745500 QUARTZ ELEMENT HC-49/S 6MHz

●DIODE

sD1

to 11 46464100 1SS133

sD12,13 03117600 1S2473

sD14

to 19 46464100 1SS133

sFL1 49959000 F.L. DISPLAY TUBE R CH1431C

sR15 48765400 A.R. 4 - 2.2 k Ω sR16 48773600 A.R. 8 - 10 k Ω sR17 48777300 A.R. 10 - 10 k Ω sC2 to 11 49417000 C.C. 50V 0.1 μ FsC13 48797300 E.L. 5.5V 3300 μ F (for Back Up)**● F - 7170B A.C. POWER CONTROL & LINE BOARD / 電源一次コントロール基板**

< Stock No. 01409100, 1, 2, 5 >

Parts No. Stock No. Description

●TRANSISTOR Δ mQ1 48508801 2SC3851**●DIODE** Δ mD1 46273600 DBB10B

mD2 46464100 1SS133

●ZENER DIODE

mDZ1 49678900 MTZJ12A

or 49679000 MTZJ12B

 Δ mR3 49863700 N.I.R. 1W 4.7 Ω Δ mPT1 15046000 POWER TRANSFORMER A395000-B

83335901 POWER TRANSFORMER R3950XX-B

83335902 POWER TRANSFORMER R3950CL-B

83335905 POWER TRANSFORMER R3950EU-B

●TRANSISTOR

pQ1 46367101 2SC2603

●DIODE Δ pD1 48123600 11E2**● F - 7168B MICROPHONE AMPLIFIER**< Stock No. 01408900 > **BOARD / マイク基板**

Parts No. Stock No. Description

●IC

gIC1 49472700 NJM4558L - D OPAMP

gC1 48662800 C.C. 50V 150 pF

gVR1 49957400 V.R. 5k Ω (B)jVR1 49957500 V.R. 250k Ω (W)

oS1 83375600 JACK HTJ - 064 - 03PG

● F - 7169B SYSTEM CONTROL & DISPLAY BOARD / システム・コントロール表示基板

< Stock No. 01409000 >

Parts No. Stock No. Description

oS61 to 101 49326300 PUSH SW. SKHVBE 5H160G TACT

● F - 7170B

Parts No.	Stock No.	Description
△pC1	46425800	C.C. 250V 0.01 μF
△pC2	48938300	C.C. 400V 100 pF (EU, FTZ, IPT)
△pF1	49594200	FUSE 125V 8A (OO)
	49628100	FUSE 5A (XX, SS)
	49594300	FUSE 125V 10A (UL, CSA)
	49297500	FUSE 250V T4A (EU, FTZ, IPT)
△pF2	49628100	FUSE 5A (XX, SS)
△pZ6	49912600	SLIDE SW. (XX, SS)
△pRL1	49523900	A.C. POWER RELAY VS12MB-NR TV8
△pZ1	49925900	OUTLET CCT1304-0111 (OO, XX, SS)
	49926000	OUTLET CCT1304-0211W (UL, CSA)
	49723000	OUTLET KE31-0090 (EU, FTZ, IPT)

● F - 7171B POWER KEY SWITCH BOARD

< Stock No. 01409200 > / 電源釦スイッチ基板

Parts No.	Stock No.	Description
oS92	49326300	PUSH SW. SKHVBE 5H160G TACT
sLD1	83383300	L.E.D. (RED) L1344ITTNB57.5

● F - 7172B BUS - LINE TERMINAL BOARD

< Stock No. 01409300 > / コントロール端子基板

Parts No.	Stock No.	Description
oC40	48663800	C.C. 50V 1000 pF
oS3	49958900	JACK (2/PCS.) JAM1796-02
oS14	83376500	TERMINAL BOARD HSP222V121 2P

● F - 7173B MAIN CIRCUIT BOARD

< Stock No. 01409500 > / 主回路基板

Parts No.	Stock No.	Description
●IC		
iIC1	07208900	NJM4558D-X OPAMP
iC10	49417000	C.C. 50V 0.1μF
●TRANSISTOR		
jQ8	46719800	DTA124ES
jQ9	46719900	DTC124ES
●IC		
jiC8	03607700	NJM4558D OPAMP
jiC9	07224800	TC4066BP
	or 46421000	μPD4066BC
	or 48063800	BU4066B
jiC10	03607700	NJM4558D OPAMP

● F - 7173B

Parts No.	Stock No.	Description
jiC11	03607700	NJM4558D OPAMP
jiC12	03607700	NJM4558D OPAMP
jC60	48666100	C.C. 50V 8200 pF
●TRANSISTOR		
kQ1	46604301	2SC3327
kQ2	46604301	2SC3327
kQ3	46604301	2SC3327
●IC		
△kiC1	49958700	STK401 - 330
△kiC2	49958600	STK4044MK2
△kiC3	49923500	STK401 - 040
●DIODE		
kD1	46464100	1SS133
△kR5	49852700	N.I.R. 1/2W 330 Ω
△kR6	49852700	N.I.R. 1/2W 330 Ω
△kR7	49284100	Ce.R. 5W 0.22 Ω
△kR8	49850500	N.I.R. 1/2W 4.7 Ω
△kR9	49863700	N.I.R. 1W 4.7 Ω
△kR14	49283300	Ce.R. 3W 0.22 Ω
△kR15	49850500	N.I.R. 1/2W 4.7 Ω
△kR16	49850500	N.I.R. 1/2W 4.7 Ω
△kR17	49852100	N.I.R. 1/2W 100 Ω
△kR18	49852100	N.I.R. 1/2W 100 Ω
△kR35	49852700	N.I.R. 1/2W 330 Ω
△kR36	49852700	N.I.R. 1/2W 330 Ω
△kR37	49284100	Ce.R. 5W 0.22 Ω
△kR38	49850500	N.I.R. 1/2W 4.7 Ω
△kR39	49863700	N.I.R. 1W 4.7 Ω
kC2	48663400	C.C. 50V 470 pF
kC32	48663400	C.C. 50V 470 pF
kC71	48663400	C.C. 50V 470 pF
kC79	48663800	C.C. 50V 1000 pF
△kL1	46851901	INDUCTOR 0.82 μH (COIL)
△kL2	46851901	INDUCTOR 0.82 μH (COIL)
△kL3	49920600	INDUCTOR 3 μH (COIL)
	or 83363900	INDUCTOR 3 μH (COIL)
●TRANSISTOR		
IQ1	46581701	2SC1845
IQ2	46581701	2SC1845
IQ3	46581701	2SC1845
IQ4	46367101	2SC2603
IQ5	46367101	2SC2603
IQ6	46367101	2SC2603
IQ7	46581701	2SC1845
IQ8	46581701	2SC1845
IQ10	46367001	2SA1115
●IC		
iIC1	46207600	TA7317P

AV-7700**AV-7150****AV-7100****● F - 7173B**

Parts No. Stock No. Description

●DIODE

ID1

to 9 46464100 1SS133

△ID10 48123600 11E2

or 83035300 11E2

ID12 46464100 1SS133

IC1 49417000 C.C. 50V 0.1 μF

IC2 49417000 C.C. 50V 0.1 μF

IC3 49417000 C.C. 50V 0.1 μF

IC6 48101500 E.B. 6.3V 100 μF

IC9 49417000 C.C. 50V 0.1 μF

IC10 49417000 C.C. 50V 0.1 μF

IC13 48101500 E.B. 6.3V 100 μF

IRL1 49962400 RELAY (SPEAKER) OMI-SS-224LM

IRL2 49730300 RELAY (SPEAKER) OSA-SS-224DM3

IRL3 49962400 RELAY (SPEAKER) OMI-SS-224LM

IRL4 49964100 RELAY (LEAD) OVR-SH-224L

●TRANSISTOR

mQ2 46581601 2SA 992

△mQ3 48508801 2SC3851

●IC

△mIC1 49772500 NJM78M56FA

△mIC2 49440800 NJM78M12FA

△mIC4 49440800 NJM78M12FA

△mIC5 49435600 NJM79M12FA

●DIODE

△mD3 03117700 10E2

△mD5 46273600 DBB10B

△mD6 03117000 RB152-LFF

mD7 46464100 1SS133

△mD8 48667600 FMU-22S

△mD9 48667700 FMU-22R

●ZENER DIODE

mDZ2 49516900 MTZJ30C

mDZ3 49676700 MTZJ6.2A

or 49676800 MTZJ6.2B

mDZ4 49516100 MTZJ24C

mDZ5 49677900 MTZJ9.1A

or 49678000 MTZJ9.1B

mDZ6 49677900 MTZJ9.1A

or 49678000 MTZJ9.1B

△mR6 49852100 N.I.R. 1/2W 100 Ω

△mR7 49852100 N.I.R. 1/2W 100 Ω

△mR8 49851300 N.I.R. 1/2W 22 Ω

△mR11 49850500 N.I.R. 1/2W 4.7 Ω

△mR13 49853000 N.I.R. 1/2W 560 Ω

● F - 7173B

Parts No. Stock No. Description

△mR14 49853000 N.I.R. 1/2W 560 Ω

△mR21 49851700 N.I.R. 1/2W 47 Ω

△mC7 0380500 C.C. 500V 0.01 μF

△mC8 0380500 C.C. 500V 0.01 μF

△mC11 0380500 C.C. 500V 0.01 μF

mC14 49961000 E.C. 42WV 3300 μF

mC15 49961000 E.C. 42WV 3300 μF

△mC16 48845500 E.C. 71WV 8200 μF

△mC17 48845500 E.C. 71WV 8200 μF

mC29

to 39 48748400 C.C. 50V 0.1 μF

●TRANSISTOR

oQ1 48223100 DTC114TS

oQ2 48223100 DTC114TS

oQ3 48229600 DTA114ES

●IC

oIC1 49475700 TC9164N

oIC2 49312200 TC9163N

oIC3 48223300 TC4028BP

oIC4 03607700 NJM4558D OPAMP

oS6 83376900 TERMINAL BOARD HSP224V81 4P

oS7 83376500 TERMINAL BOARD HSP222V121 2P

oS8 83377600 TERMINAL BOARD HSP226V901 6P

oS9 83377300 TERMINAL BOARD HSP226V81 6P

oS13 83382000 TERMINAL BOARD HSP232V1Y 2P

oS11 83376100 SP. - TERMINAL 8P HSP-308V-11

qZ73 49666700 FLAT CABLE L125-22P FFC 2896

● F - 7174B CENTER SPEAKER TERMINAL BOARD / センター・スピーカー端子基板

<Stock No. 01409600 >

Parts No. Stock No. Description

oS10 83375900 SP. - TERMINAL 2P HSP-302V-04

● F - 7175B HEADPHONE JACK TERMINAL BOARD / ヘッド・ホン・ジャック端子基板

<Stock No. 01409700 >

Parts No. Stock No. Description

△kR41 49852500 N.I.R. 1/2W 220 Ω

oS2 83375700 JACK HTJ-064-07NG

AV-7100**AV-7150****AV-7700**

● **F - 7176B OUTPUT POWER SELECTOR BOARD / スピーカー出力調節基板**

< Stock No. 01409800 , 5 >

Parts No. Stock No. Description

●TRANSISTOR

IQ9 46719900 DTC124ES
IQ11 48229400 DTA114TS

●DIODE

ID11 46464100 1SS133
△IRL5 49958500 RELAY OMI-SS-224L
△pF8 49593900 FUSE 125V 4A (00, XX, UL, CSA, SS)
49297500 FUSE 250V T4A (EU, FTZ, IPT)

● **F - 7177B SECONDARY FUSE BOARD**

< Stock No. 01409900 > / 二次ヒューズ基板

Parts No. Stock No. Description

△pF5 49593300 FUSE 125V 1A (00, XX, UL, CSA, SS)
△pF6 49593300 FUSE 125V 1A (00, XX, UL, CSA, SS)

● **F - 7178B VIDEO SELECTOR BOARD**

< Stock No. 01410000 > / ビデオ切り替え基板

Parts No. Stock No. Description

oC38 48663800 C.C. 50V 1000 pF
oC39 48663800 C.C. 50V 1000 pF
oS4 83382000 TERMINAL BOARD HSP232V1Y 2P
oS5 83382000 TERMINAL BOARD HSP232V1Y 2P

●TRANSISTOR

rQ1 46367101 2SC2603
rQ2 46367101 2SC2603
rQ3 46834300 DTC144ES
or 49388300 RN1204
rQ4 46367101 2SC2603
rQ5 46367101 2SC2603
rQ6 46367101 2SC2603
rQ7 46834300 DTC144ES
or 49388300 RN1204

●IC

rIC1 49475500 NJM2245D VIDEO SWITCH
△rR15 49851500 N.I.R. 1/2W 33 Ω
rC1 48662600 C.C. 50V 100 pF
rC2 48662600 C.C. 50V 100 pF
rC8 48662600 C.C. 50V 100 pF

● **F - 7211B DE - BUG CIRCUIT SELECTOR**

< Stock No. 01410000 > BOARD (EU, IPT, FTZ only)

Parts No. Stock No. Description

●TRANSISTOR

sQ50 46719900 DTC124ES
sQ51 46719800 DTA124ES
sQ52 46834300 DTC144ES
sQ53 46367101 2SC2603
sQ54 46367101 2SA1115

●IC

sIC50 49741000 TC74HC123AP

●DIODE

sD50
to 53 46464100 1SS133
sLD50 83383300 L.E.D. (RED) L1344ITTNB57.5
sC51 48663800 C.C. 50V 1000 pF
sC54 49417000 C.C. 50V 0.1 μF
sS50 49367900 PUSH SWITCH SPEC 2 CIRCUIT

FIXED PARTS

Parts No. Stock No. Description

△mPT2 15045900 POWER TRANSFORMER A3950 00
15045801 POWER TRANSFORMER R2910 XX
15045902 POWER TRANSFORMER R2910 CL
15045905 POWER TRANSFORMER R2910 EU
oS12 22301510 GRAND TERMINAL KD41 - 0042
△pZ2 49511510 POWER SUPPLY CORD (00)
46321000 POWER SUPPLY CORD (XX)
48187800 POWER SUPPLY CORD (UL,CSA)
or 83384600 POWER SUPPLY CORD (UL,CSA)
48837700 POWER SUPPLY CORD (SS)
or 83384200 POWER SUPPLY CORD (SS)
49299300 POWER SUPPLY CORD (EU,IPT,FTZ)
or 83384300 POWER SUPPLY CORD (EU,IPT,FTZ)
△pZ5 49374300 STRAIN RELIEF CORD BUSH 2φ4

* NOTE

Last figure of stock number in "< >" means the destination for market.

If you are not found out the number, will be shown in stock number smaller than it.

0: JAPAN, 1: EXPORT, 2: U. S. A., 3: CANADA,
4: MID. EAST, 5: EUROPE, 7: ITALY,
8: GERMANY (C E STANDARD)

* *(For receiver only!! * For the other markets than Japanese!!) * *

● F - 7166A AUDIO CONTROL BOARD

< Stock No. 01407101 >

Parts No. Stock No. Description

●TRANSISTOR

jQ1 46719900 DTC124ES
jQ2 46719800 DTA124ES
jQ3 46719900 DTC124ES
jQ4 46719800 DTA124ES

●IC

jIC1 07224800 TC4066BP
or 46421000 μ PD4066BC
or 48063800 BU4066B
jIC2 48982600 LB1641
jIC3 49558900 TC9184P
jIC4 49439500 NJM4558L OPAMP
jIC5 07224800 TC4066BP
or 46421000 μ PD4066BC
or 48063800 BU4066B
jIC6 03607700 NJM4558D OPAMP
jIC7 49439500 NJM4558L OPAMP

●ZENER DIODE

jDZ1 49677900 MTZJ9.1A
or 49678000 MTZJ9.1B
jDZ2 49677900 MTZJ9.1A
or 49678000 MTZJ9.1B
jDZ3 49675800 MTZJ4.7A
or 49675900 MTZJ4.7B
 Δ jR1 49852100 N.I.R. 1/2W 100 Ω
 Δ jR2 49852100 N.I.R. 1/2W 100 Ω
jC3 48666200 C.C. 16V 0.01 μ F
jC4 48666200 C.C. 16V 0.01 μ F
jC5 48666200 C.C. 16V 0.01 μ F
jC6 48666200 C.C. 16V 0.01 μ F
jC7 48663600 C.C. 50V 680 pF
jC10 48659600 C.C. 50V 27 pF
jC13 48659600 C.C. 50V 27 pF
jC15 48665500 C.C. 50V 2700 pF
jC17 48426900 C.C. 25V 22000 pF
jC19 48659800 C.C. 50V 33 pF
jC23 49417000 C.C. 50V 0.1 μ F
jC24 49417000 C.C. 50V 0.1 μ F
jC27 49417000 C.C. 50V 0.1 μ F
jC29 48666200 C.C. 16V 0.01 μ F
jC30 49417000 C.C. 50V 0.1 μ F
jC34 48662700 C.C. 50V 120 pF
jVR2 49957600 V.R. 100 k Ω (B) X 4 WITH L.E.D.
 Δ pF7 49593900 FUSE 125V 4A
 Δ pF8 49593900 FUSE 125V 4A

● F - 7167A D.S.P. - SURROUND & VOICE
CANCELL BOARD

< Stock No. 01407201 >

Parts No. Stock No. Description

●TRANSISTOR

xQ1 46359801 2SC2001

●IC

xIC1 49439500 NJM4558L OPAMP
xIC2 49471900 TC9162N
xIC3 49915800 LA2780N
xIC4 49471900 TC9162N
xIC5 49439500 NJM4558L OPAMP
xIC6 49915900 LV1001MA
xIC7 49916000 LM33256G-12
or 49916200 LH21256-12
or 49963700 LC32256P-80
xIC11 49439500 NJM4558L OPAMP
xIC13 49440100 TC9213P
xIC14 49439500 NJM4558L OPAMP
xIC15 49439500 NJM4558L OPAMP
xXO1 49774600 QUARTZ ELEMENT HC-49/S 8MHz

●ZENER DIODE

xDZ1 49676400 MTZJ5.6A
or 49676500 MTZJ5.6B
xC3 48662600 C.C. 50V 100 pF
xC4 49417000 C.C. 50V 0.1 μ F
xC15 48748400 C.C. 50V 0.1 μ F
xC16 48748400 C.C. 50V 0.1 μ F
xC17 48663600 C.C. 50V 680 pF
xC31 48663600 C.C. 50V 680 pF
xC32 48748400 C.C. 50V 0.1 μ F
xC33 48748400 C.C. 50V 0.1 μ F
xC34 48748400 C.C. 50V 0.1 μ F
xC35 48663600 C.C. 50V 680 pF
xC37 48659800 C.C. 50V 33 pF
xC44 48659800 C.C. 50V 33 pF
xC69 48660000 C.C. 50V 39 pF
xC75 48665500 C.C. 50V 2700 pF
xC84 49929300 F.C. 100V 150pF APS (P. P.)
xC85 48426900 C.C. 25V 22000 pF
xC91 48102500 E.B. 25V 10 μ F
xC94 48659800 C.C. 50V 33 pF
xC97 48426900 C.C. 25V 22000 pF
xC101 49929300 F.C. 100V 150pF APS (P. P.)
xC103 49417000 C.C. 50V 0.1 μ F
xC104 48666200 C.C. 16V 0.01 μ F
xC105 48659800 C.C. 50V 33 pF
xC107 48659800 C.C. 50V 33 pF
xC110 49417000 C.C. 50V 0.1 μ F

RZ-8100AV**RZ-8150AV****● F - 7167A**

Parts No. Stock No. Description

xC111	48659600	C.C. 50V 27 pF
xC112	48659600	C.C. 50V 27 pF
xC115	48665700	C.C. 50V 3900 pF
xC117	48665800	C.C. 50V 4700 pF
xC118	48102500	E.B. 25V 10 μ F
xC120	48102500	E.B. 25V 10 μ F
xC131	48103400	E.B. 50V 1 μ F
xC142	48102500	E.B. 25V 10 μ F
xC143	48660000	C.C. 50V 39 pF
xC148	48659000	C.C. 50V 15 pF
xC149	48102500	E.B. 25V 10 μ F
xC150	48658200	C.C. 50V 4.7 pF
xC151	48658200	C.C. 50V 4.7 pF
xC152	48659800	C.C. 50V 33 pF
xC153	49417000	C.C. 50V 0.1 μ F
xC154	49417000	C.C. 50V 0.1 μ F

● F - 7168A MICROPHONE AMPLIFIER BOARD

< Stock No. 01407301 >

Parts No. Stock No. Description

●IC		
gIC1	49472700	NJM4558L-D OPAMP
gC1	48662800	C.C. 50V 150 pF
gVR1	49957400	V.R. 5 k Ω (B)
jVR1	49957500	V.R. 250 k Ω (W)
oS1	83375600	JACK HTJ - 064 - 03PG

● F - 7169A SYSTEM CONTROL & DISPLAY BOARD

< Stock No. 01407401 >

Parts No. Stock No. Description

oS61		
to 104	49326300	PUSH SW. SKHVBE 5H160G TACT
sIC2	49550900	REMOTE CONTIROL RECEIVER SBX1610-52
●TRANSISTOR		
sQ1, 2	48223100	DTC114TS
sQ3 to 5	46834300	DTC144ES
sQ8		
to 11	46719900	DTC124ES
sQ12	48217800	DTC114ES
sQ13	46719800	DTA124ES
●IC		
sIC1	49922000	M. P. U. TMP47C1270AN-H221
sXO1	49745500	QUARTZ ELEMENT HC-49/S 6MHz

● F - 7169A

Parts No. Stock No. Description

●DIODE		
sD1		
to 11	46464100	1SS133
sD12	03117600	1S2473T77
sD13	03117600	1S2473T77
sD14		
to 20	46464100	1SS133
sFL1	49920100	F.L. DISPLAY TUBE R CH1226C
sR15	48765400	A.R. 4 - 2.2 k Ω
sR16	48773600	A.R. 8 - 10 k Ω
sR17	48777300	A.R. 10 - 10 k Ω
sC2	49417000	C.C. 50V 0.1 μ F
sC4, 5	49417000	C.C. 50V 0.1 μ F
sC11	49417000	C.C. 50V 0.1 μ F
sC13	48797300	E.L. 5.5V 3300 μ F (for Back Up)

● F - 7170A A.C. POWER CONTROL & LINE BOARD

< Stock No. 01407501 >

Parts No. Stock No. Description

●TRANSISTOR		
Δ mQ1	48508801	2SC3851
●DIODE		
Δ mD1	46273600	DBB10B
mD2	46464100	1SS133
●ZENER DIODE		
mDZ1	49678900	MTZJ12A
or	49679000	MTZJ12B
Δ mR3	49863700	N.I.R. 1W 4.7 Ω
Δ mPT1	83335901	POWER TRANSFORMER R3950XX-B
	83335902	POWER TRANSFORMER R3950QL-B
	83335905	POWER TRANSFORMER R3950EJ-B
●TRANSISTOR		
pQ1	46367101	2SC2603
●DIODE		
Δ pD1	48123600	11E2
Δ pC1	46425800	C.C. 250V 0.01 μ F
Δ pF1	49628100	FUSE 5A (XX, S)
	49594300	FUSE 125V 10A (UL, CSA)
	49297500	FUSE 250V T4A (EU, FTZ, PT)
Δ pF2	49628100	FUSE 5A (XX, S)
pZ6	49912600	SLIDE SW. (XX, S)
Δ pRL1	49523900	A.C. POWER RELAY VS12MB-NR \sqrt{V} 8
Δ pZ1	49925900	OUTLET CCT1304-0111 (XX, S)
	49926000	OUTLET CCT1304-0211W (UL, CSA)
	49723000	OUTLET KE31-0090 (EU, FTZ, PT)

● F - 7171A POWER KEY SWITCH BOARD

< Stock No. 01407601 >

Parts No.	Stock No.	Description
oS92	49326300	PUSH SW. SKHVBE 5H160G TACT
sLD1	83383300	L.E.D. (RED) L1344ITTNB57.5

● F - 7172A BUS - LINE TERMINAL BOARD

< Stock NO. 01407701 >

Parts No.	Stock No.	Description
oS3	49958900	JACK (2/PCS.) JAM1796-02

● F - 7173A MAIN CIRCUIT BOARD

< Stock No. 01407901 >

Parts No.	Stock No.	Description
-----------	-----------	-------------

●IC

iIC1	07208900	NJM4558D-X OPAMP
iC10	49417000	C.C. 50V 0.1 μF

●TRANSISTOR

jQ8	46719800	DTA124ES
jQ9	46719900	DTC124ES

●IC

jIC8	03607700	NJM4558D OPAMP
jIC9	07224800	TC4066BP
	or 46421000	μPD4066BC
	or 48063800	BU4066B

jIC10	03607700	NJM4558D OPAMP
jIC11	03607700	NJM4558D OPAMP
jIC12	03607700	NJM4558D OPAMP
jC60	48666100	C.C. 50V 8200 pF

●TRANSISTOR

kQ1	46604301	2SC3327
kQ2	46604301	2SC3327
kQ3	46604301	2SC3327

●IC

ΔkIC1	49958700	STK401 - 330
ΔkIC2	49958600	STK4044MK2
ΔkIC3	49923500	STK401 - 040

●DIODE

kD1	46464100	1SS133
ΔkR5	49852700	N.I.R. 1/2W 330 Ω
ΔkR6	49852700	N.I.R. 1/2W 330 Ω
ΔkR7	49284100	Ce.R. 5W 0.22 Ω
ΔkR8	49850500	N.I.R. 1/2W 4.7 Ω
ΔkR9	49863700	N.I.R. 1W 4.7 Ω

● F - 7173A

Parts No. Stock No. Description

ΔkR14	49283300	Ce.R. 3W 0.22 Ω
ΔkR15	49850500	N.I.R. 1/2W 4.7 Ω
ΔkR16	49850500	N.I.R. 1/2W 4.7 Ω
ΔkR17	49852100	N.I.R. 1/2W 100 Ω
ΔkR18	49852100	N.I.R. 1/2W 100 Ω
ΔkR35	49852700	N.I.R. 1/2W 330 Ω
ΔkR36	49852700	N.I.R. 1/2W 330 Ω
ΔkR37	49284100	Ce.R. 5W 0.22 Ω
ΔkR38	49850500	N.I.R. 1/2W 4.7 Ω
ΔkR39	49863700	N.I.R. 1W 4.7 Ω
kC2	48663400	C.C. 50V 470 pF
kC32	48663400	C.C. 50V 470 pF
kC71	48663400	C.C. 50V 470 pF
kC79	48663800	C.C. 50V 1000 pF
kL1	46851901	INDUCTOR 0.82 μH (COIL)
kL2	46851901	INDUCTOR 0.82 μH (COIL)
kL3	49920600	INDUCTOR 3 μH (COIL)
	or 83363900	INDUCTOR 3 μH (COIL)

●TRANSISTOR

IQ1 to 3	46581701	2SC1845
IQ4 to 6	46367101	2SC2603
IQ7	46581701	2SC1845
IQ8	46581701	2SC1845
IQ10	46367001	2SA1115

●IC

iIC1	46207600	TA7317P
------	----------	---------

●DIODE

ID1 to 9	46464100	1SS133
ΔID10	48123600	11E2
	or 83035300	11E2
ID12	46464100	1SS133
IC1 to 3	49417000	C.C. 50V 0.1 μF
IC6	48101500	E.B. 6.3V 100 μF
IC9	49417000	C.C. 50V 0.1 μF
IC10	49417000	C.C. 50V 0.1 μF
IC13	48101500	E.B. 6.3V 100 μF
IRL1	49962400	RELAY (SPEAKER) OMI-SS-224LM
IRL2	49730300	RELAY (SPEAKER) OSA-SS-224DM3
IRL3	49962400	RELAY (SPEAKER) OMI-SS-224LM
IRL4	49964100	RELAY (LEAD) OVR-SH-224L

●TRANSISTOR

mQ2	46581601	2SA 992
ΔmQ3	48508801	2SC3851

●IC

ΔmIC1	49772500	NJM78M56FA
ΔmIC2,4	49440800	NJM78M12FA
ΔmIC3	49440700	NJM78M09FA
ΔmIC5	49435600	NJM79M12FA

RZ-8100AV**RZ-8150AV****● F - 7173A**

Parts No. Stock No. Description

●DIODE

△mD3 03117700 10E2
 △mD5 46273600 DBB10B
 △mD6 03117000 RB152-LFF
 mD7 46464100 1SS133
 △mD8 48667600 FMU-22S
 △mD9 48667700 FMU-22R

●ZENER DIODE

mDZ2 49516900 MTZJ30C
 mDZ3 49676700 MTZJ6.2A
 or 49676800 MTZJ6.2B
 mDZ4 49516100 MTZJ24C
 mDZ5 49677900 MTZJ9.1A
 or 49678000 MTZJ9.1B
 mDZ6 49677900 MTZJ9.1A
 or 49678000 MTZJ9.1B
 △mR6 49852100 N.I.R. 1/2W 100 Ω
 △mR7 49852100 N.I.R. 1/2W 100 Ω
 △mR8 49851300 N.I.R. 1/2W 22 Ω
 △mR11 49850500 N.I.R. 1/2W 4.7 Ω
 △mR13 49853000 N.I.R. 1/2W 560 Ω
 △mR14 49853000 N.I.R. 1/2W 560 Ω
 △mR21 49851700 N.I.R. 1/2W 47 Ω
 △mC7 00380500 C.C. 500V 0.01 μF
 △mC8 00380500 C.C. 500V 0.01 μF
 △mC11 00380500 C.C. 500V 0.01 μF
 mC14 49961000 E.C. 42WV 3300 μF
 mC15 49961000 E.C. 42WV 3300 μF
 △mC16 48845500 E.C. 71WV 8200 μF
 △mC17 48845500 E.C. 71WV 8200 μF
 mC29
 to 39 48748400 C.C. 50V 0.1 μF

●TRANSISTOR

oQ1 48223100 DTC114TS
 oQ2 48223100 DTC114TS
 oQ3 48229600 DTA114ES

●IC

oIC1 49475700 TC9164N
 oIC2 49312200 TC9163N
 oIC3 48223300 TC4028BP
 oIC4 03607700 NJM4558D OPAMP
 oS6 83376900 TERMINAL BOARD HSP224V81 4P
 oS7 83376500 TERMINAL BOARD HSP222V121 2P
 oS8 83377600 TERMINAL BOARD HSP226V901 6P
 oS9 83377300 TERMINAL BOARD HSP226V81 6P
 oS11 83376100 SP. - TERMINAL 8P HSP-308V-11
 qZ73 49666700 FLAT CABLE L125-22P FFC 2896

● F - 7174B CENTER SPEAKER TERMINAL BOARD

< Stock No. 01408001 >

Parts No. Stock No. Description

oS10 83375900 SP. - TERMINAL 2P HSP-302V-04

● F - 7175B HEADPHONE JACK TERMINAL BOARD

< Stock No. 01408101 >

Parts No. Stock No. Description

△kR41 49852500 N.I.R. 1/2W 220 Ω
 oS2 83375700 JACK HTJ-064-07NG

● F - 7176B OUTPUT POWER SELECTOR BOARD

< Stock No. 01408201 >

Parts No. Stock No. Description

●TRANSISTOR

IQ9 46719900 DTC124ES
 IQ11 48229400 DTA114TS

●DIODE

ID11 46464100 1SS133
 △IRL5 49958500 RELAY OMI-SS-224L
 xVR1 48079600 S.V.R. 47 kΩ (B)

● F - 7177A SECONDARY FUSE BOARD

< Stock No. 01408301 >

Parts No. Stock No. Description

△pF5 49593300 FUSE 125V 1A (00, XX, UL, CSA, SS)
 or 49296900 FUSE 250V T1A (EU, IPT, FTZ)
 △pF6 49593300 FUSE 125V 1A (00, XX, UL, CSA, SS)
 or 49296900 FUSE 250V T1A (EU, IPT, FTZ)

● F - 7178B VIDEO SELECTOR BOARD

< Stock No. 01408401 >

Parts No. Stock No. Description

oC38 48663800 C.C. 50V 1000 pF
 oC39 48663800 C.C. 50V 1000 pF
 oS4 83382000 TERMINAL BOARD HSP232V1Y 2P
 oS5 83382000 TERMINAL BOARD

●TRANSISTOR

rQ1, 2 46367101 2SC2603

● F - 7178A

Parts No. Stock No. Description

rQ3 46834300 DTC144ES
or 49388300 RN1204
rQ4 46367101 2SC2603

●IC

rIC1 49475500 NJM2245D VIDEO SWITCH
△rR15 49851500 N.I.R. 1/2W 33 Ω
rC1 48662600 C.C. 50V 100 pF
rC2 48662600 C.C. 50V 100 pF

● F - 7179A TUNNING CIRCUIT BOARD

< Stock No. 01408501 >

Parts No. Stock No. Description

dZ1 49954000 FRONT END UNIT TFFJ2U1

●TRANSISTOR

dQ1 48171600 DTC114YS
or 49388600 RN1207
dQ2 46393201 2SC2786
dQ3 to 7 48171600 DTC114YS
or 49388600 RN1207
dQ8 46367301 2SC2458
or 48058801 2SC1740S

●IC

dIC1 49948100 LA1832
dXO1 49591000 QUARTZ ELEMENT CSB456F15 MPX

●DIODE

dD1 to 8 46464100 1SS133
dC1 48426900 C.C. 25V 22000 pF
dC6 48665800 C.C. 50V 4700 pF
dC7 48426900 C.C. 25V 22000 pF
dC8 48663700 C.C. 50V 820 pF (XX, UL, CSA, SS)
48663800 C.C. 50V 1000 pF (EU, IPT, FTZ)
dC11 48663500 C.C. 50V 560 pF (XX, SS)
dC12 49417000 C.C. 50V 0.1 μF
dC13 48663800 C.C. 50V 1000 pF
dC14 48659400 C.C. 50V 22 pF
dC18 49428900 C.C. 16V 12000 pF (XX, SS, EU, IPT, FTZ)
49429100 C.C. 16V 18000 pF (UL, CSA)
dCF1, 2 46202500 CERAMIC FILTER (XX, UL, CSA, SS)
SFE10.7MS2H-A (R)
48064800 CERAMIC FILTER (EU, IPT, FTZ)
SFE10.7MS3GH-A (R)
dCF3 49947800 CERAMIC FILTER CDA10.7MG46-A
dLP1 49914800 LOW PASS FILTER (19 / 38kHz)
dVR1 46634900 S.V.R. 100 kΩ (B)
dZ3 48719000 ANTENNA TERMINAL T5945-A 1PL

● F - 7178A

Parts No. Stock No. Description

dZ2 83377800 ANTENNA TERMINAL 2P
HSP-302V-02 (XX, UL, CSA, SS)
83376400 ANTENNA TERMINAL 2-2P
HSP-312V-02 (EU, IPT, FTZ)
eC1 49416900 C.C. 50V 0.047 μF
eC2 48663800 C.C. 50V 1000 pF
eC4 49417000 C.C. 50V 0.1 μF
eT1 49952700 **A.M. R.F.** COIL AT-0923
eT2 49591100 CERAMIC FILTER CF-0812 (XX, UL, CSA, SS)
49591200 CERAMIC FILTER CF-0816 (EU, IPT, FTZ)

●TRANSISTOR

fQ1, 2 46367301 2SC2458
or 48058801 2SC1740S
fQ3, 4 48183400 DTA114YS
or 49390800 RN2207
fQ5, 6 46834300 DTC144ES
or 49388300 RN1204

●IC

fIC1 49317500 LC7218
fXO1 49773500 QUARTZ ELEMENT HC-49/U 7.2MHz
fC1, 6 48426900 C.C. 25V 22000 pF
fC2, 8 48663800 C.C. 50V 1000 pF
fC3 48103600 E.B. 50V 3.3 μF
fC5 48102500 E.B. 25V 10 μF
fC7 48658600 C.C. 50V 10 pF
fC9, 10 48659600 C.C. 50V 27 pF
oS110 49599400 SLIDE SW. SSSU14 (XX, SS)

● F - 7211B DE - BUG CIRCUIT SELECTOR< Stock No. 01410000 > **BOARD** (EU, IPT, FTZ only)

Parts No. Stock No. Description

●TRANSISTOR

sQ50 46719900 DTC124ES
sQ51 46719800 DTA124ES
sQ52 46834300 DTC144ES
sQ53 46367101 2SC2603
sQ54 46367101 2SA1115

●IC

sIC50 49741000 TC74HC123AP

●DIODE

sD50
to 53 46464100 1SS133
sLD50 83383300 L.E.D. (RED) L1344ITTNB57.5
sC51 48663800 C.C. 50V 1000 pF
sC54 49417000 C.C. 50V 0.1 μF
sS50 49367900 PUSH SWITCH SPEC 2 CIRCUIT

RZ-8100AV**RZ-8150AV****AV-7100****AV-7150****AV-7700****FIXED PARTS**

Parts No.	Stock No.	Description
△mPT2	15045801	POWER TRANSFORMER R2910 XX
	15045902	POWER TRANSFORMER R2910 CL
	15045905	POWER TRANSFORMER R2910 EU
△oS12	22301510	GRAND TERMINAL KD41 - 0042
	△pZ2	46321000
or 83384600	48187800	POWER SUPPLY CORD (UL,CSA)
	48837700	POWER SUPPLY CORD (SS)
	49299300	POWER SUPPLY CORD (EU,IPT,FTZ)
	or 83384200	POWER SUPPLY CORD (SS)
	or 83384300	POWER SUPPLY CORD (EU,IPT,FTZ)
△pZ5	49374300	STRAIN RELIEF CORD BUSH 2104

***NOTE**

Last figure of stock number in "< >" means the destination for market.

If you are not found out the number, will be shown in stock number smaller than it.

- 1 : EXPORT , 2 : U. S. A. , 3 : CANADA ,
 4 : MID. EAST , 5 : EUROPE , 7 : ITALY ,
 8 : GERMANY (C E STANDARD)

Stock No.	Description
85178700	LEG (D : 55 X H : 13)
05283600	LEG CUSHION (□ 15 X 15)

8. MECHANISM PARTS LIST / 機構部品表**●AMPLIFIER < AV-7100, AV7150 & AV7700 >**

Parts No.	Stock No.	Description
1	85174400	FRONT PANEL ALUMINIUM GOLD
	85174300	FRONT PANEL ALUMINIUM BLACK
	85184200	FRONT PANEL (JAPAN) GOLD
2	85197000	FRONT PANEL (JAPAN) BLACK
	85174810	KNOB ACC. (B.- PANEL.) GOLD
3	85174710	KNOB ACC. (B.- PANEL.) BLACK
	85180400	BONNET GOLD
	85178100	BONNET BLACK
4	85183200	BONNET (EU , IPT , FTZ) GOLD
	85183100	BONNET (EU , IPT , FTZ) BLACK
	85175010	WINDOW
5	85179500	SUB PANEL PLASTICS GOLD
	85179400	SUB PANEL PLASTICS BLACK
6	85175400	KNOB MASTER VOLUME GOLD
	85175300	KNOB MASTER VOLUME BLACK
7	85175800	KNOB INPUT SELECTOR GOLD
	85175700	KNOB INPUT SELECTOR BLACK
8	85166400	KNOB VOLUME GOLD
	85166300	KNOB VOLUME BLACK
9	85176000	KNOB MULTI CONTROL GOLD
	85175900	KNOB MULTI CONTROL BLACK
10	05272600	LOGO BADGE SANSUI GOLD
	05051200	LOGO BADGE SANSUI BLACK
11	85166900	INDICATOR STANDBY
12	85180200	INDICATOR MASTER VOL. KNOB
13	85211900	KNOB POWER (EU,IPT,FTZ) GOLD
	85211800	KNOB POWER (EU,IPT,FTZ) BLACK

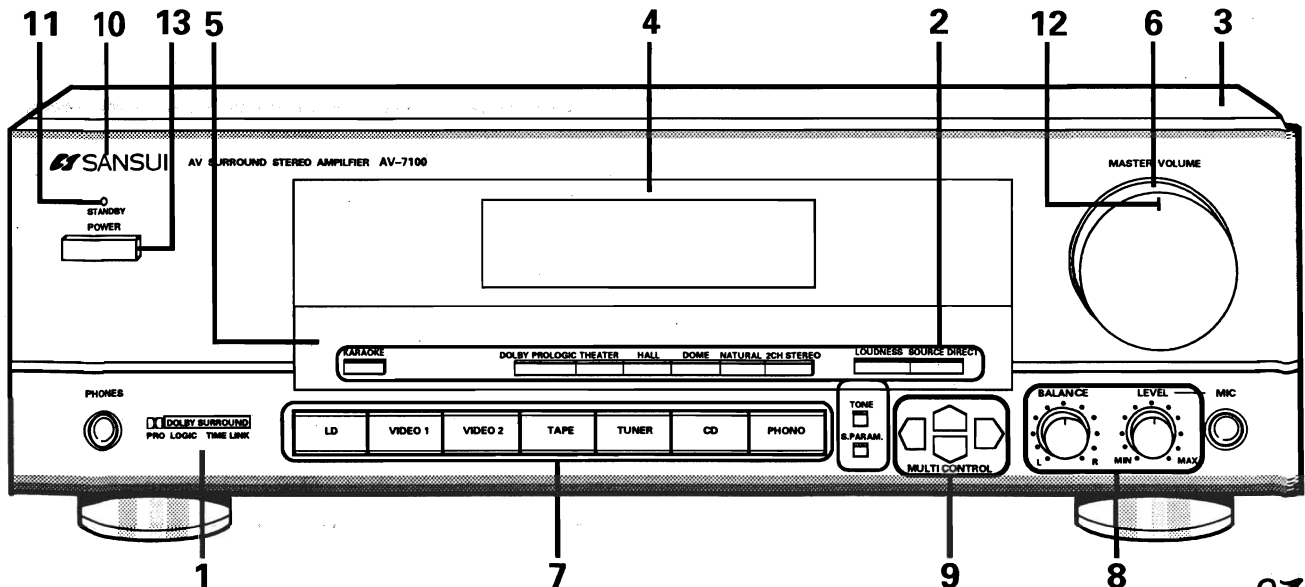

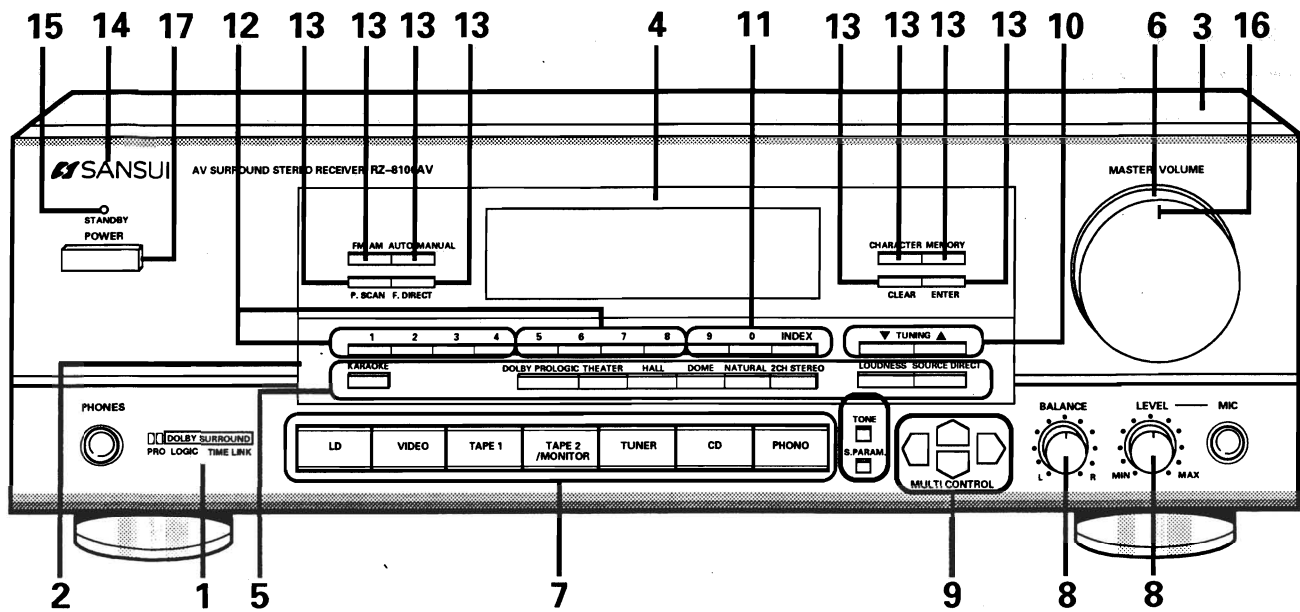
AV-7700**AV-7150****AV-7100****RZ-8150AV****RZ-8100AV**

●RECEIVER ◀ RZ-8100AV & RZ-8100AV ▶

Parts No. Stock No. Description

1	85174200 FRONT PANEL ALUMINIUM GOLD	
	85174100 FRONT PANEL ALUMINIUM BLACK	
2	85174810 KNOB ACC. (B.- PANEL.) GOLD	
	85174710 KNOB ACC. (B.- PANEL.) BLACK	
3	85180400 BONNET GOLD	
	85178100 BONNET BLACK	
	85183200 BONNET (EU, IPT, FTZ) GOLD	
	85183100 BONNET (EU, IPT, FTZ) BLACK	
4	85174910 WINDOW	
5	85175200 SUB PANEL PLASTICS GOLD	
	85175100 SUB PANEL PLASTICS BLACK	
6	85175400 KNOB MASTER VOLUME GOLD	
	85175300 KNOB MASTER VOLUME BLACK	
7	85175600 KNOB INPUT SELECTOR GOLD	
	85175500 INPUT SELECTOR BLACK	
8	85166400 KNOB VOLUME GOLD	
	85166300 KNOB VOLUME BLACK	

Parts No. Stock No. Description

9	85176000 KNOB MULTI CONTROL GOLD	
	85175900 KNOB MULTI CONTROL BLACK	
10	85176200 KNOB 2-PIECES GOLD	
	85176100 KNOB 2-PIECES BLACK	
11	85176400 KNOB 3-PIECES GOLD	
	85176300 KNOB 3-PIECES BLACK	
12	85176600 KNOB 4-PIECES GOLD	
	85176500 KNOB 4-PIECES BLACK	
13	85184500 KNOB SINGLE (ON THE WINDOW)	
14	05272600 LOGO BADGE SANSUI GOLD	
	05051200 LOGO BADGE SANSUI BLACK	
15	85166900 INDICATOR STANDBY	
16	85180200 INDICATOR MASTER VOL. KNOB	
17	85211900 KNOB POWER (EU, IPT, FTZ) GOLD	
	85211800 KNOB POWER (EU, IPT, FTZ) BLACK	
	85178700 LEG (D : 55 X H : 13)	
	05283600 LEG CUSHION (□ 15 X 15)	

●BOTH MODEL ◀ AMPLIFIER & RECEIVER ▶

Stock No. Description

85184300	GRILLE (ON BONNET EU, IPT, FTZ) GOLD
85183300	GRILLE (ON BONNET EU, IPT, FTZ) BLACK
85179600	FL FILTER ANBER (FOR BLACK MODEL)
85179700	FL FILTER PINK (FOR GOLD MODEL)
85179600	FL FILTER PINK (FOR JAPAN MODEL)

9. PACKING LIST

／ 梱包材部品表

●AMPLIFIER < AV-7100, AV7150 & AV7700 >

Parts No. Stock No. Description

1	85179900 CARTON CASE	GOLD
	85179800 CARTON CASE	BLACK
	85180100 CARTON CASE (JAPAN)	GOLD
	85180000 CARTON CASE (JAPAN)	BLACK
2	85178800 POLYSTYRENE FOAM PACKING	LEFT
3	85178900 POLYSTYRENE FOAM PACKING	RIGHT
4	85203800 POLYETHYLEN BAG	LARGE

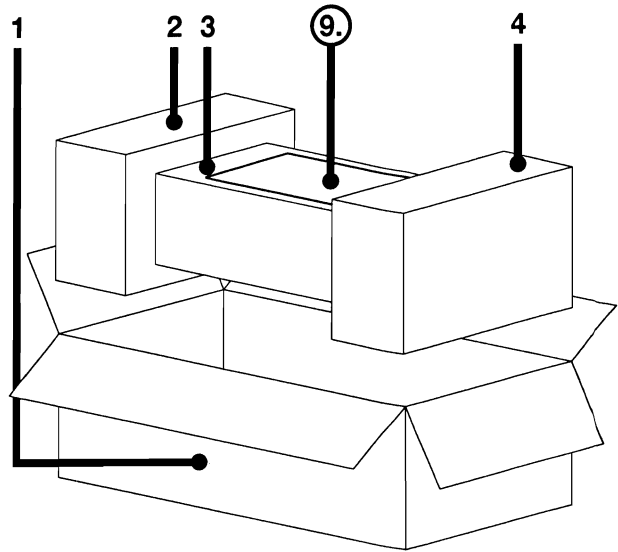

10. ACCESSORY LIST

／ 付属品部品表

●AMPLIFIER < >

Stock No. Description

49958800	REMOTE CONTROL UNIT	RS - 1700
	DRY BATTERY CELL ASS'Y (2PCS., R6 / SUM3)	
47852000	POLYETHYLEN BAG	SMALL
82036000	OPERATING INSTRUCTION	*(J)
82036100	OPERATING INSTRUCTION	*(E , F , S)
82036200	OPERATING INSTRUCTION	*(8L)
82036300	OPERATING INSTRUCTION	*(ET)

***NOTE**

- J : Japanese Version.
- E, F, S : English, French and Spanish Version.
- 8 L : English, French, Spanish, German, Italian, Swedish, Portuguese and Netherlands Version.
- E, T : English and Old Chinese Character Version.

RZ-8150AV**RZ-8100AV**

11. PACKING LIST

●RECEIVER < RZ-8100AV & RZ-8100AV >

Parts No. Stock No. Description

1	85179100	CARTON CASE	GOLD
	85179000	CARTON CASE	BLACK
2	85178800	POLYSTYRENE FOAM PACKING	LEFT
3	85178900	POLYSTYRENE FOAM PACKING	RIGHT
4	85203800	POLYETHYLEN BAG	LARGE

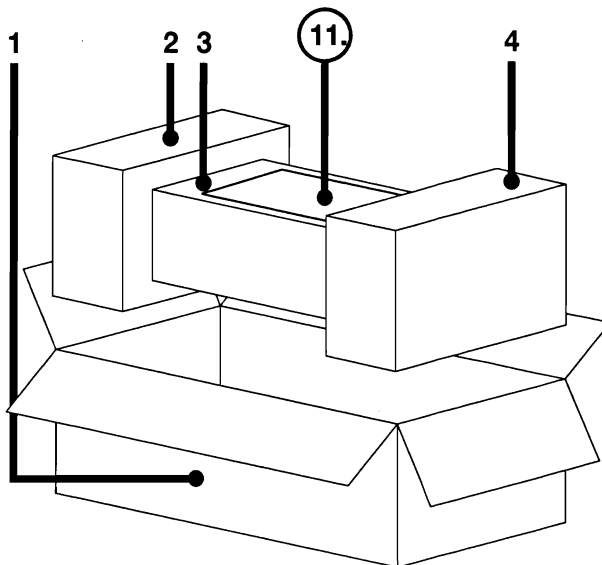

12. ACCESSORY LIST

●RECEIVER < RZ-8100AV & RZ-8100AV >

Stock No. Description

49919100	REMOTE CONTROL UNIT	RS-1560
	DRY BATTERY CELL ASS'Y (2PCS., R6/SUM3)	
83382100	A. M. ANTENNA	(R. F. LOOP COIL)
83390500	F. M. ANTENNA	(T-TYPE WIRE)
83390400	F. M. ANTENNA	(T-TYPE EUROPE)
49335000	ANTENNA CONNECTOR	(EUROPE)
47852000	POLYETHYLEN BAG	SMALL
82035700	OPERATING INSTRUCTION	*(E, F, S)
82035800	OPERATING INSTRUCTION	*(8L)
82035900	OPERATING INSTRUCTION	*(ET)

***NOTE**

E, F, S : English, French and Spanish Version.

8 L : English, French, Spanish, German, Italian, Swedish, Portuguese and Netherlands Version.

E, T : English and Old Chinese Character Version.

36732800
SM RZ8100AV/AV7100

824054 Liefermenge: 1

SANSUI

SANSUI ELECTRIC CO., LTD. :

22 Sekinoue, Namekawa, Sukagawa-shi, Hukusima 962-04, Japan
Phone: (0248) 75-4174 / Fax: (0248) 76-6445

SANSUI INTERNATIONAL CO., LTD. :

Units B10-B11, 2/F, Block B Hoplite Industrial Centre 3-5 Wang Tai Road,
Kowloon Bay Kowloon, Honk Kong

SANSUI USA INC. :

17150 South Margay Ave. Carson, California 90746 U.S.A.

SANSUI DEUTSCHLAND G.M.B.H. :

Paul Ehrlich Strasse 8, 6074Rödermark 2, F. R. Germany

山水電気株式会社

福島県須賀川市大字滑川字関の上22 (〒962-04)

A3850 & R2910 (SM 2-428) Printed in Hong Kong (1996.06.SI) <Stock No.36732800>