

# SERVICE MANUAL

STEREO CASSETTE TAPE DECK

## SANSUI SC-1100/1110



### SPECIFICATIONS

TRACK . . . . .	4-Track (2-Channel Stereo)
TAPE SPEED . . . . .	4.8 cm/sec. (1-7/8 ips)
HEADS . . . . .	Record/Playback: Hard Permalloy Head
	Erase: Ferrite Head
MOTOR . . . . .	Electronically Controlled DC Motor
WOW AND FLUTTER . . . . .	within 0.08% WRMS
FAST WIND TIME . . . . .	approximately 75 sec. (C-60)
FREQUENCY RESPONSE (Record/Playback)	
Normal Tape (LH)	30 to 13,000 Hz (35 to 12,500 Hz ±3 dB)
Chromium Tape	30 to 16,000 Hz (35 to 13,000 Hz ±3 dB)
SIGNAL TO NOISE RATIO (Record/Playback)	
Chromium Tape	without Dolby Noise Reduction better than 54 dB (weighted)
	with Dolby Noise Reduction better than 64 dB (above 5 kHz)
ERASURE FACTOR . . . . .	more than 60 dB at 1,000 Hz
INPUT SENSITIVITY & IMPEDANCE (0 VU, 1,000 Hz)	
MIC . . . . .	0.2 mV 200Ω ~ 10 kΩ
LINE . . . . .	70 mV 100 kΩ
	DIN Connector Socket
	0.2 mV 4.7 kΩ
OUTPUT LEVEL (0 VU, 1,000 Hz)	
LINE . . . . .	400 mV
	DIN Connector Socket
	400 mV
HEADPHONE IMPEDANCE . . . . .	8Ω
BIAS FREQUENCY . . . . .	85 kHz
POWER REQUIREMENTS	
Voltage . . . . .	100, 120, 220, 240V 50/60 Hz
	120V (Usable 110 ~ 130V) 60 Hz
	(For U.S.A. & Canada only)
Consumption . . . . .	13W (rated)
DIMENSIONS . . . . .	451 mm (17-3/4") W, 170 mm (6-3/4") H, 307 mm (12-1/8") D (SC-1100)
WEIGHT . . . . .	6.4 kg (14.1 lbs.) net (SC-1100)
	7.9 kg (17.4 lbs.) packed (SC-1100)
DIMENSIONS . . . . .	430 mm (17") W, 160 mm (6-3/8") H, 307 mm (12-1/8") D (SC-1110)
WEIGHT . . . . .	6.8 kg (15.0 lbs.) net (SC-1110)
	8.3 kg (18.3 lbs.) packed (SC-1110)

† Dolby is a trademark of Dolby Laboratories, Inc.

\* Design and specifications subject to change without notice for improvements.

**Sansui**

SANSUI ELECTRIC CO., LTD.

# 1. BLOCK DIAGRAM

## ◇Recording Operation Block Diagram

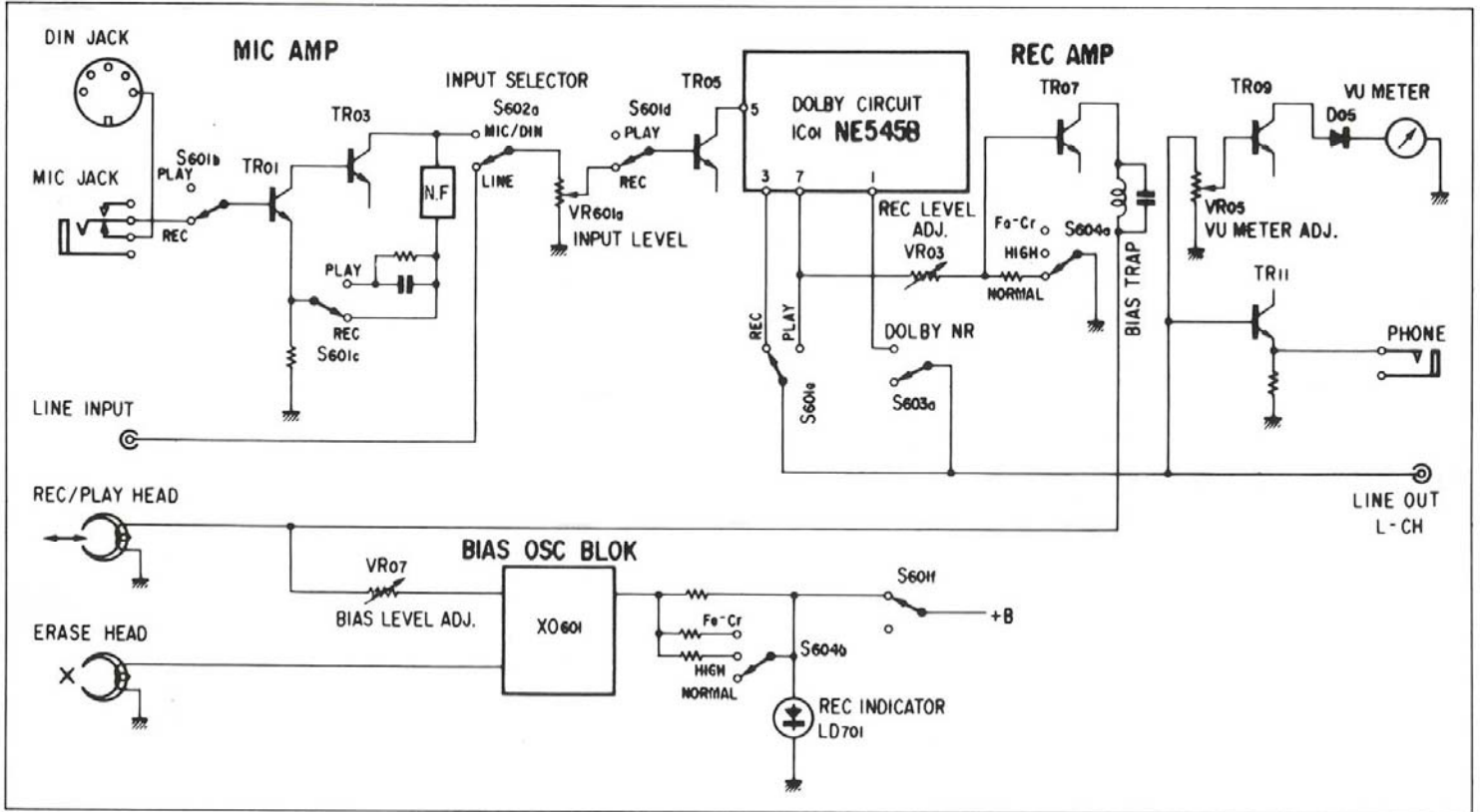

## ◇Playback Operation Block Diagram

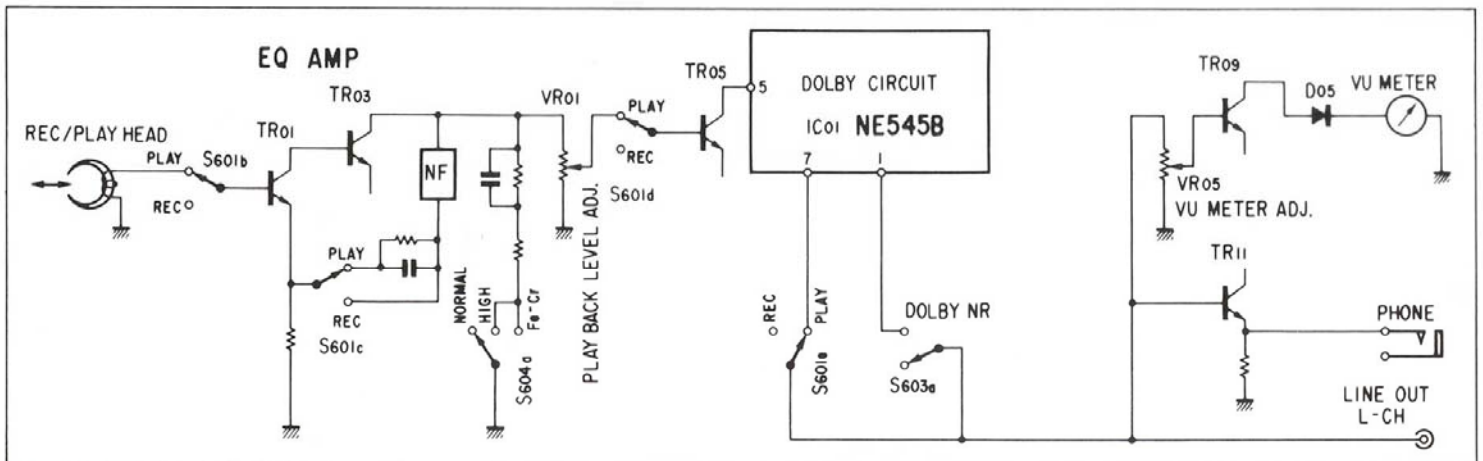

# 2. ADJUSTMENTS

\* List of Sansui Test Tapes

Name of test tape	Recorded Frequency	Description
SCT-S3K	3 kHz	Speed Check, Wow & Flutter Check
SCT-L400N	400 Hz	Playback level and VU meter level adjustment
SCT-F1K	1 kHz	High frequency equalization check
SCT-F10KN	10 kHz	REC/PB head adjustment
SCT-SA [HIGH (CrO <sub>2</sub> )]		Recording bias adjustment
SCT-LH [NORMAL (LH)]		REC/PB level adjustment
SCT-CS (Fe-Cr)		Frequency response check
SCT-F40	40 Hz	Playback frequency response check

## 1) Tape Speed Adjustment

- Note: (1) Use Sansui Test Tape, SCT-S3K (3 kHz signals are recorded on the tape).  
 (2) Connections are shown below.

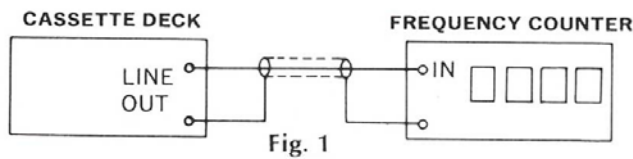

SUBJECT	INPUT SIGNAL	CHECK POINT	SETTING	ADJUST FOR	ADJUST	DESCRIPTION
TAPE SPEED ADJ.	Test Tape SCT-S3K	LINE OUT	Depress the PLAY button and playback the Test Tape, SCT-S3K	3000 Hz ±2%	If not, turn semi-variable resistor as Fig. 2 until 3000 Hz ±2% is obtained.	Use small screw driver.

## 2) Playback Adjustment

- Note: (1) Before this adjustment, clean REC/P.B head surface.  
 (2) Demagnetize the head by demagnetizer, if necessary.  
 (3) For this adjustment, use Sansui Test Tape, SCT-F10KN, SCT-L400N and SCT-F1K.  
 (4) Set the Dolby switch to be OFF.  
 (5) Connections are shown below.

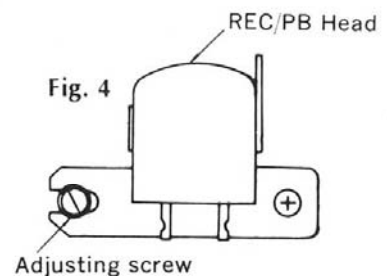
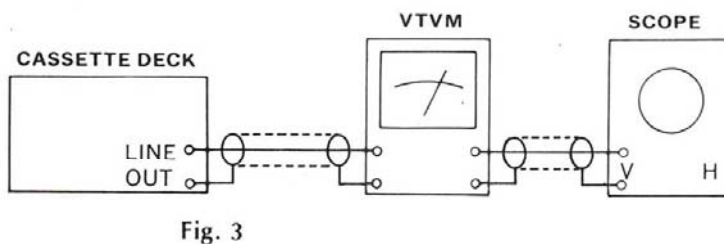

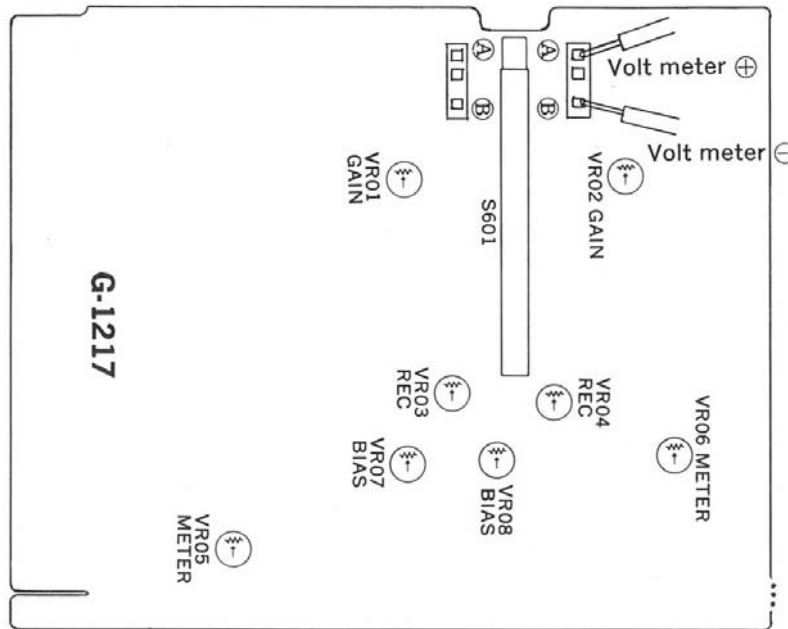

Fig. 5 **G-1217 Main Circuit Board**

※By turning all adjustment volumes clockwise, each level of Rec, Play, Meter and Bias Current is increased.

SUBJECT	INPUT SIGNAL	CHECK POINT	SETTING	ADJUST FOR	DESCRIPTION
REC/PB Head Adj.	SCT-F10KN	LINE OUT	Depress the PLAY button and playback the test Tape, SCT-F10KN	Adjust the azimuth adjusting screw in Fig. 4 and tape guide for the maximum reading on the VTVM on both channels.	After this adjustment, lock the screw with paint.
Playback Level Adj.	SCT-L400N	LINE OUT	Set TAPE SELECTOR to NORMAL (LH) position Depress the PLAY button and playback the Test Tape, SCT-L400N	Adjust VR01 (47 k $\Omega$ ) for L-CH and VR02 (47 k $\Omega$ ) for R-CH for the reading of 560 mV $\pm$ 1 dB on VTVM (See Fig. 5)	Set same level (560 mV) $\pm$ 1 dB on both channels
VU meter Level Adj.			Adjust VR05 (15 k $\Omega$ ) for L-CH and VR06 (15 k $\Omega$ ) for R-CH for the reading of +3VU $\pm$ 1VU on VTVM (See Fig. 5).		
High frequency Equalization Check	SCT-F1K and SCT-F10KN	LINE OUT	Set TAPE SELECTOR to NORMAL (LH) position. Depress the PLAY button and playback the Test Tape, SCT-F1K and SCT-F10KN	Confirm that the difference of output levels from SCT-F1K and SCT-F10KN is within $\pm$ 4 dB	In playback of SCT-10KN, set the TAPE SELECTOR to HIGH (CrO <sub>2</sub> ) position, then confirm the indication on VTVM dropping down approximately 4 dB.

### 3) Recording Adjustment

(1) Connection.

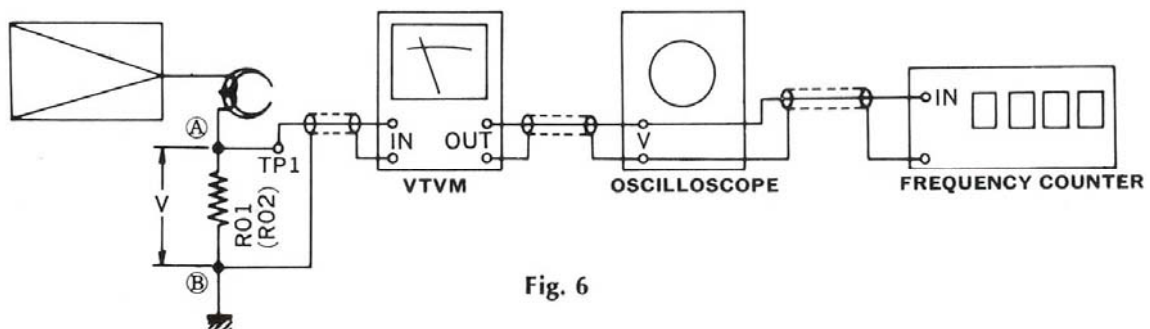

Fig. 6



SUBJECT	INPUT SIGNAL	CHECK POINT	SETTING	ADJUST	DESCRIPTION
Recording bias Adj.		Voltage value between A and B of R01 & R02 (See Fig. 6)	Depress REC and PLAY buttons.  Set TAPE SELECTOR to HIGH (CrO <sub>2</sub> ) position.  Set TAPE SELECTOR to NORMAL (LH) position. Set TAPE SELECTOR to Fe-Cr position.	Adjust VR07 (100kΩ) for L-CH and VR08 (100kΩ) for R-CH for the reading of 80 mV between A and B in Fig. 6 on both channels.  Confirm the indication on V T V M shows 46 mV. Confirm the indication on V T V M shows 60 mV.	
Bias Frequency		Same as above	Set TAPE SELECTOR to NORMAL position.	Confirm that frequency counter shows 85 kHz ±10 kHz.-	

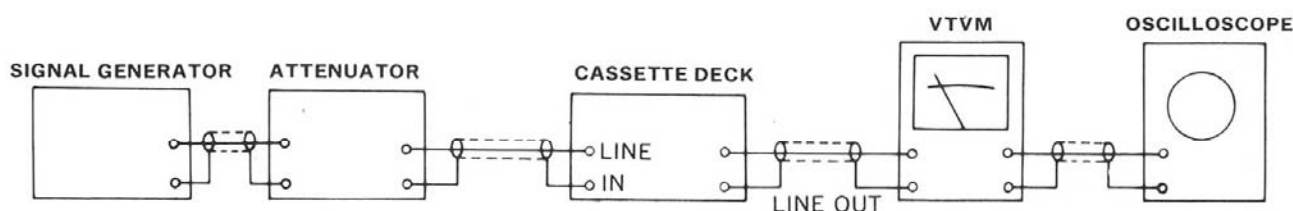

Fig. 7

SUBJECT	INPUT SIGNAL	CHECK POINT	SETTING	ADJUST FOR	DESCRIPTION
REC Level Adj. HIGH (CrO <sub>2</sub> )	Use recording HIGH (CrO <sub>2</sub> ) tape SCT-SA  Feed 1 kHz, 70 mV (0 dB) from S.G into LINE IN.	LINE OUT	Set TAPE SELECTOR to HIGH (CrO <sub>2</sub> ) position 1. Depress PAUSE, PLAY and REC button. 2. Adjust the MIC/LINE volume for obtaining 0 dB on the VU meters. 3. Push off the PAUSE button, then record the 1 kHz signal. 4. Play back the 1 kHz signal. 5. Confirm that the output levels on both channels are 400 mV ±2 dB on V T V M	1. If not, turn VR03 (15 kΩ) for L-CH and VR04 (15 kΩ) for R-CH until output Level, 400 mV ±2 dB on both channels are obtained. 2. Repeat this REC Level adj. until the indication on V T V M will be 400 mV ±2 dB. (See Fig. 5)	
Frequency Response Adj. HIGH (CrO <sub>2</sub> )	Feed 1 kHz, 7 mV (-20dB) and 10 kHz; 7 mV (-20dB) from S.G. into LINE IN.	LINE OUT	Set TAPE SELECTOR to HIGH (CrO <sub>2</sub> ) position. 1. Record the 1 kHz and 10 kHz signals from S.G. 2. Play back the 1 kHz and 10 kHz signals, then confirm that the difference of output levels between 1 kHz and 10 kHz are within 0 dB against that of 1 kHz.	1. If not, adjust VR07 (100 kΩ) for L-CH and VR08 (100 kΩ) for R-CH slightly until difference of output levels between 1 kHz and 10 kHz recorded are within 0 dB against that of 1 kHz (See Fig. 5)	As VR07 and VR08 are previously adjusted in step of Bias Adjustment, turn them slightly, if necessary. (See Fig. 5)

※TAPE SELECTOR position

TAPE	MODE	TAPE SELECTOR position	
		REC	PLAY
AGFA	Hifi-Low-Noise SUPER	normal (LH)	normal (LH)
BASF	LN		
	LH		
	LH super		
FUJI FILM	FL		
	FX		
	FX Duo		
MAXELL	LN UD-XLI		
SCOTCH	LD		
	LH		
	CRYSTAL		
SONY	LOW-NOISE HF		
TDK	D		
	SD		
	ED		

TAPE	MODE	TAPE SELECTOR position	
		REC	PLAY
AGFA	STEREO CHROM	high (CrO <sub>2</sub> )	high (CrO <sub>2</sub> )
BASF	chromdioxid		
MAXELL	UD-XLI		
SONY	CR		
TDK	SA		
BASF	ferrochrom	Fe-Cr	Fe-Cr
SCOTCH	CLASSIC		
SONY	DUAD		
SCOTCH	Master	normal (LH)	high (CrO <sub>2</sub> )
TDK	AD	normal (LH)	normal (LH)
FUJI FILM	FX Jr		
MAXELL	UD		

# 4. PARTS LOCATION & PARTS LIST

Since some of capacitors and resistors are omitted from parts lists in this Service Manual, refer to the common parts list for capacitors & resistors which was appended previously to each Sansui Manual.

## 1) G-1217 Main Circuit Board (Stock No. 7620091) (SC-1100) Conductor Side (Stock No. 7620111) (SC-1110)

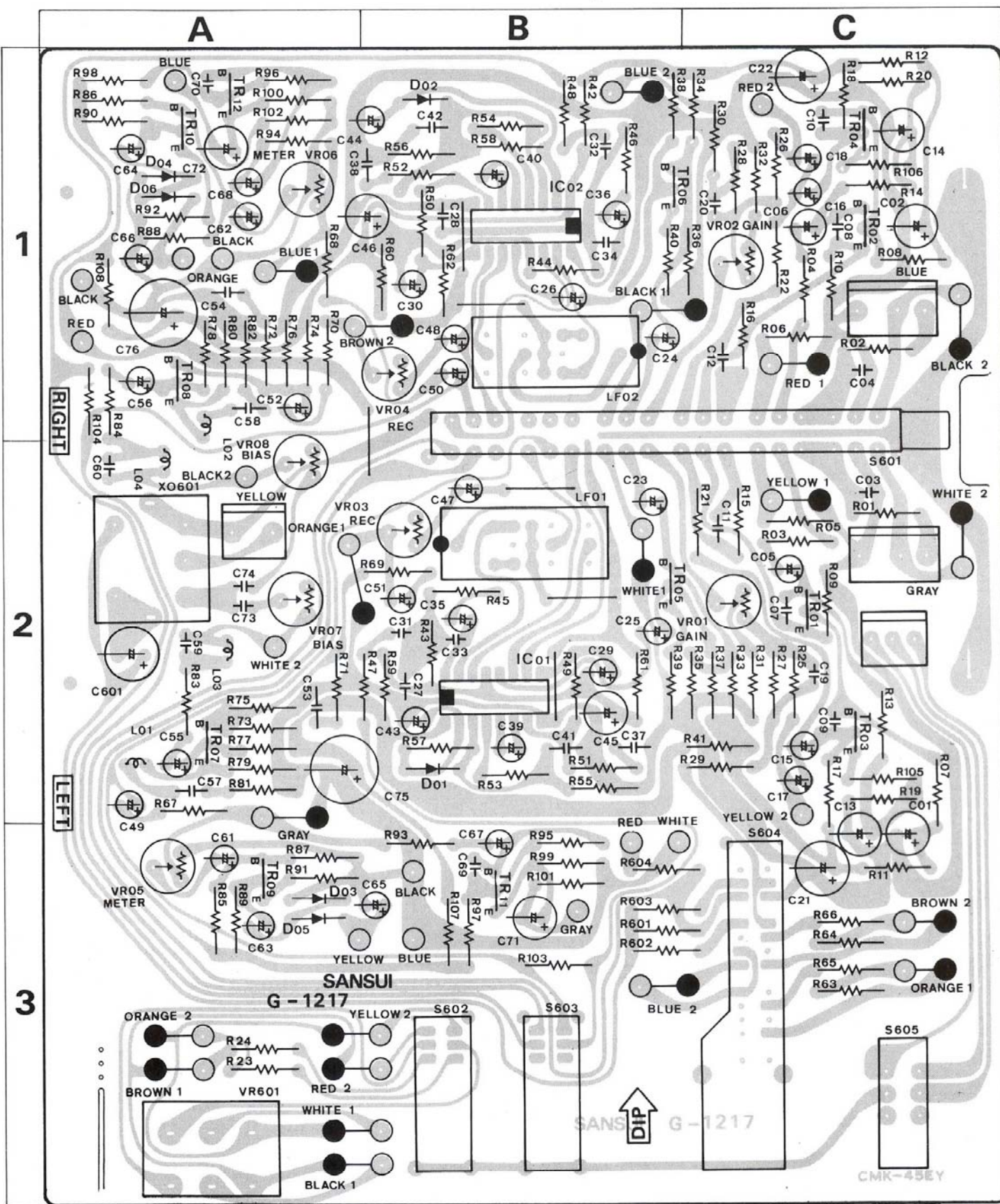



Parts List (G-1217)

Parts No.	Stock No.	Description	Position
TR01 ~ 06	0306091, 2	2SC1312R (G), (H)	Transisto 1, 2C 1 ~ 3A
TR07 ~ 12	0305951, 2	2SC945 (Q, (P)	
IC 01, 02	0360340	NE545B	IC 2B, 1B
D 01 ~ 06	0310331	1N60	Diode 1 ~ 3A
C 59, 60	0620101	100 pF	50V P.C. 2A
L 01, 02	4900170	4.7 mH	Inductor 2A 2A
L 03, 04	4290310	33 mH	
LF 01, 02	0910390	Ceramic Filter	1, 2B
VR01, 02	1035170	47 kΩ (B) VR, pb level	2C, 1C
VR03, 04	1035140	15 kΩ (B) VR, rec level	2B, 1B
VR05, 06	1035140	15 kΩ (B) VR, VU meter level	3A, 1A

Parts No.	Stock No.	Description	Position
VR07, 08	1035190	100 kΩ (B) VR, bias level	2A
VR601	1020280	50 kΩ (A) x 2 VR, input level	3A
S 601	1110340	Slide Switch, rec-play switch	1, 2C
S 602	1171130	Lever Switch, input selector	3B
S 603	1171130	Lever Switch, dolby NR	3B
S 604	1190440	Rotary Switch, tape selector	3C
S 605	1131450	Push Switch, tape lead-in	3C
XO601	0825030	OSC block	3A
	2410840	3P Pin Ass'y Type B	
	2410910	2P Pin Ass'y Type E	
	2410920	3P Pin Ass'y Type E	

2) G-1218 Power Supply Circuit Board (Stock No. 7502411) (SC-1100)  
(Stock No. 7502571) (SC-1110)

Conductor Side

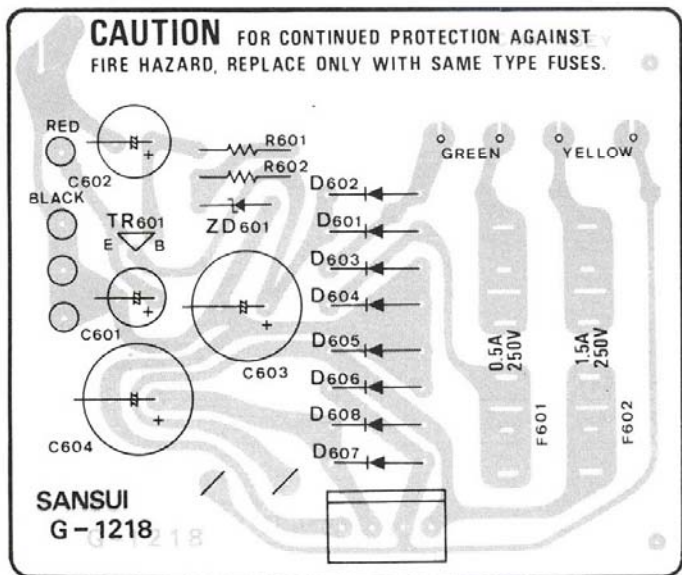

Parts List

Parts No.	Stock No.	Description
TR601	0308392, 3	2SD313AL (E), (F) Transistor
D 601 ~ 608	0310340	10D1 (1S2226) Diode
ZD601	0315990	EQA01-15R Zener Diode
F 601	0432210	0.5A 250V AC Fuse
F 602	0432230	1.5A 250V AC Fuse
	2310220	Fuse Holder
	2410850	4P Pin Ass'y Type B

3) G-1232 Voltage Selector Circuit Board (Stock No. 7690321) (SC-1100)  
(Stock No. 7690361) (SC-1110)

Conductor Side

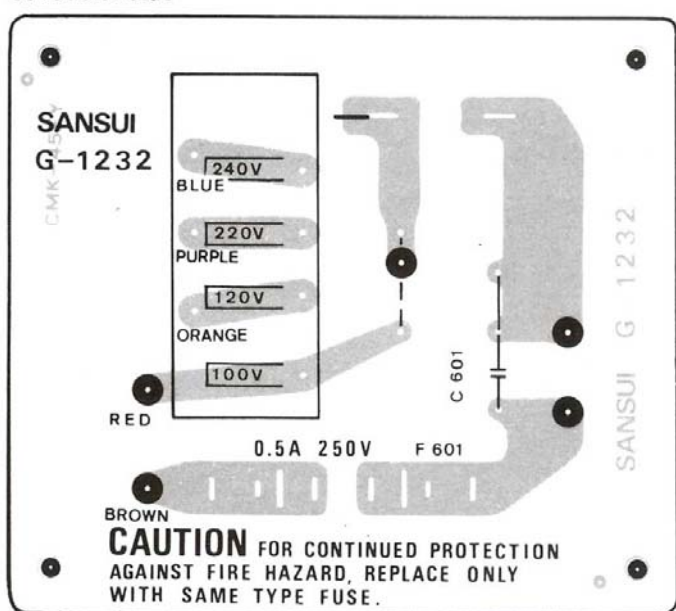

Parts List

Parts No.	Stock No.	Description
C 601	0659801	0.01 μF 150V C.C.
F 601	0432210	0.5A 250V Power Fuse

#### 4) G-1230 Lead-in and Shut-off Circuit Board (Stock No. 7595750)

Conductor Side

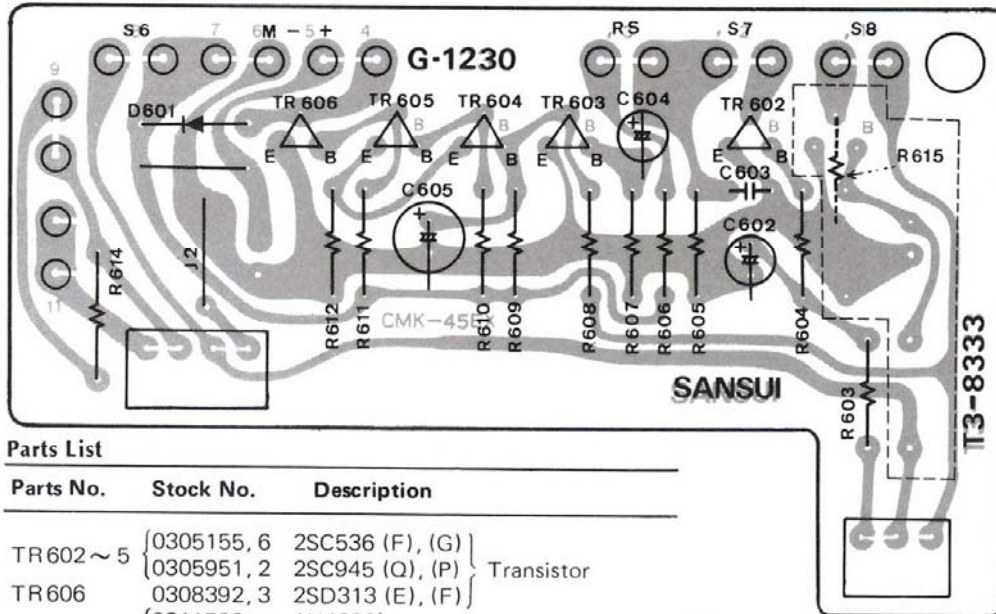

##### Parts List

Parts No.	Stock No.	Description
TR602 ~ 5	{0305155, 6 0305951, 2 0308392, 3}	{2SC536 (F), (G) 2SC945 (Q), (P) 2SD313 (E), (F)}
TR606	{0311500 0310340}	{1N4002 10D1}
D 601	{0311500 0310340}	{1N4002 10D1}
R 614	0200101	100Ω 1/2W N.I.R.
	2420500	3P Pin Ass'y Type A
	2020510	4P Pin Ass'y Type A

#### 5) G-1219 Input-Output Circuit Board (Stock No. 7690291) (SC-1100) (Stock No. 7960331) (SC-1110)

Conductor Side

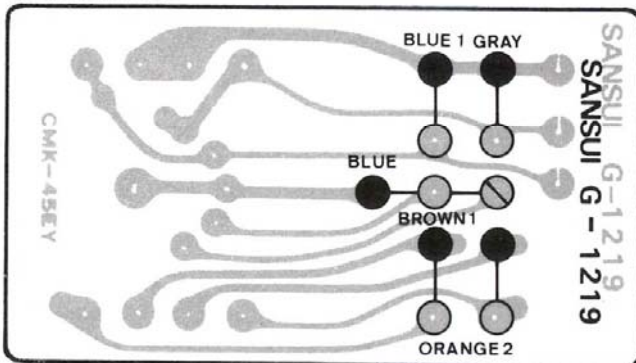

##### Parts List

Parts No.	Stock No.	Description
	7710100	Input-Output Terminal Ass'y

#### 6) G-1220 Microphone Jack Circuit Board (Stock No. 7690301) (SC-1100) (Stock No. 7690341) (SC-1110)

Conductor Side

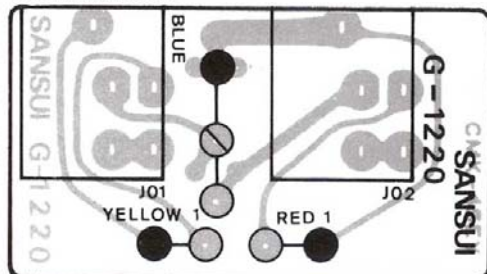

##### Parts List

Parts No.	Stock No.	Description
	2430330	Microphone Jack

#### 7) G-1231 Headphone Jack Circuit Board (Stock No. 7690311) (SC-1100) (Stock No. 7690351) (SC-1110)

Conductor Side

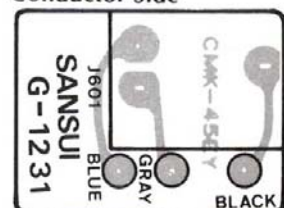

##### Parts List

Parts No.	Stock NO.	Description
	2430320	Headphone Jack



# 4. DISASSEMBLY WITH EXPLODED VIEWS & PARTS LIST

## Front View

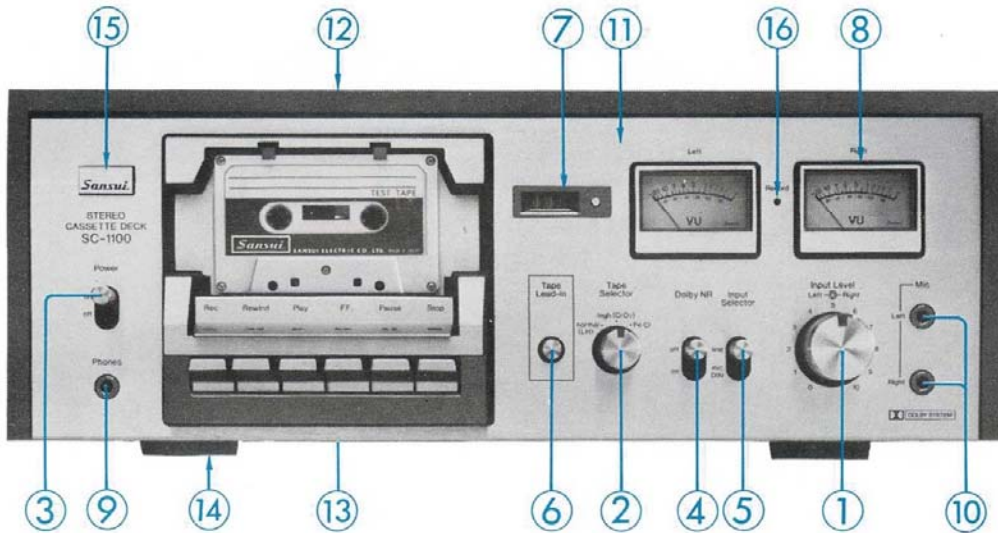

### Parts List

Parts No.	Stock No.	Description
1	5310220	WI-8 Type L-ch knob (SC-1100)
	5310200	WO-11 Type R-ch knob (SC-1100)
	5310270	WI-10 Type L-ch knob (SC-1110)
	5310280	WO-13 Type R-ch knob (SC-1110)
	1020280, 1	50 kΩ (A) x 2 VR, input level
	2	5310240
5310260		E-17 Type knob (SC-1110)
5326680		Lever Switch knob (SC-1100)
3	5326611	Lever Switch knob (SC-1110)
	1171600	Lever Switch, power (SC-1100)
4	1171640	Lever Switch, power (SC-1110)
	5326680	Lever Switch knob (SC-1100)
5	5326611	Lever Switch knob (SC-1110)
	1171130	Lever Switch, dolby NR
	5326680	Lever Switch knob (SC-1100)
6	5326611	Lever Switch knob (SC-1110)
	1171130	Lever Switch, input selector
	5326660	Push Switch knob (SC-1100)
	5320430	Push Switch knob (SC-1110)

Parts No.	Stock No.	Description
7	1131450	Push Switch, tape lead-in
	5430130	Tape Counter Ass'y
8	0400610	Counter Lamp 8V 65 mA
	4301100	VU Meter
9	2430320	Headphone Jack
10	2430330	Microphone Jack
11	7000140	Front Panel Ass'y (SC-1100)
	7000160	Front Panel Ass'y (SC-1110)
12	5740230	Wood Bonnet (SC-1100)
	5236560	Bushing (SC-1100)
13	5109931	B Type Screw, 4 x 20 (SC-1100)
	5000030	Bonnet (SC-1110)
	5109937	B Type Screw, 4 x 12 (SC-1110)
14	5120561	P Type Washer (SC-1110)
	5050220	Bottom plate
15	5109122	BT Type Screw, 3 x 8
16	5507070	Leg
	5332080	Sansui Badge
	0319020	Light Emitted Diode (red), rec lamp

## ● Figures

### Connectors & Pin Ass'y

#### Connectors

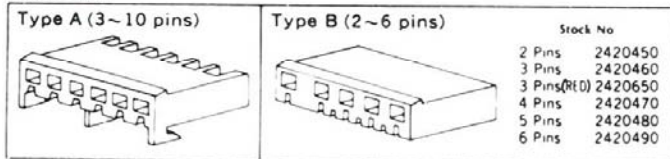

NOTE: Since stock number of female connectors (type B) with wires are not shown in each parts list of Complete circuit board, please refer to the above parts list when ordering the connector

#### Pin Ass'y

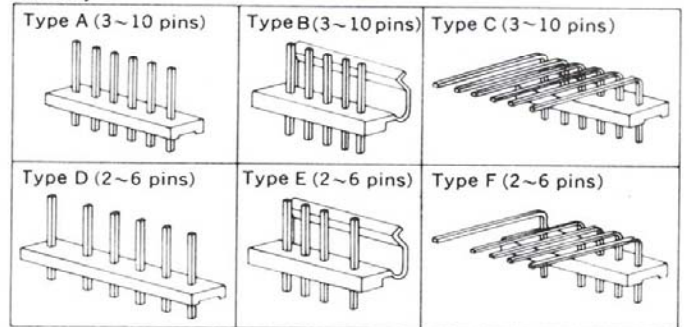

### Abbreviations

<b>C.R.</b> : Carbon Resistor	<b>E.C.</b> : Electrolytic Capacitor
<b>S.R.</b> : Solid Resistor	<b>BP.E.C.</b> : Bi-Polar Electrolytic Capacitor
<b>Ce.R.</b> : Cement Resistor	<b>C.C.</b> : Ceramic Capacitor
<b>M.R.</b> : Metal Film Resistor	<b>Mi.C.</b> : Mica Capacitor
<b>F.R.</b> : Fusing Resistor	<b>O.C.</b> : Oil Capacitor
<b>N.I.R.</b> : Non-Inflammable Resistor	<b>P.C.</b> : Polystyrene Capacitor
<b>M.C.</b> : Mylar Capacitor	<b>T.C.</b> : Tantalum Capacitor

# Top View

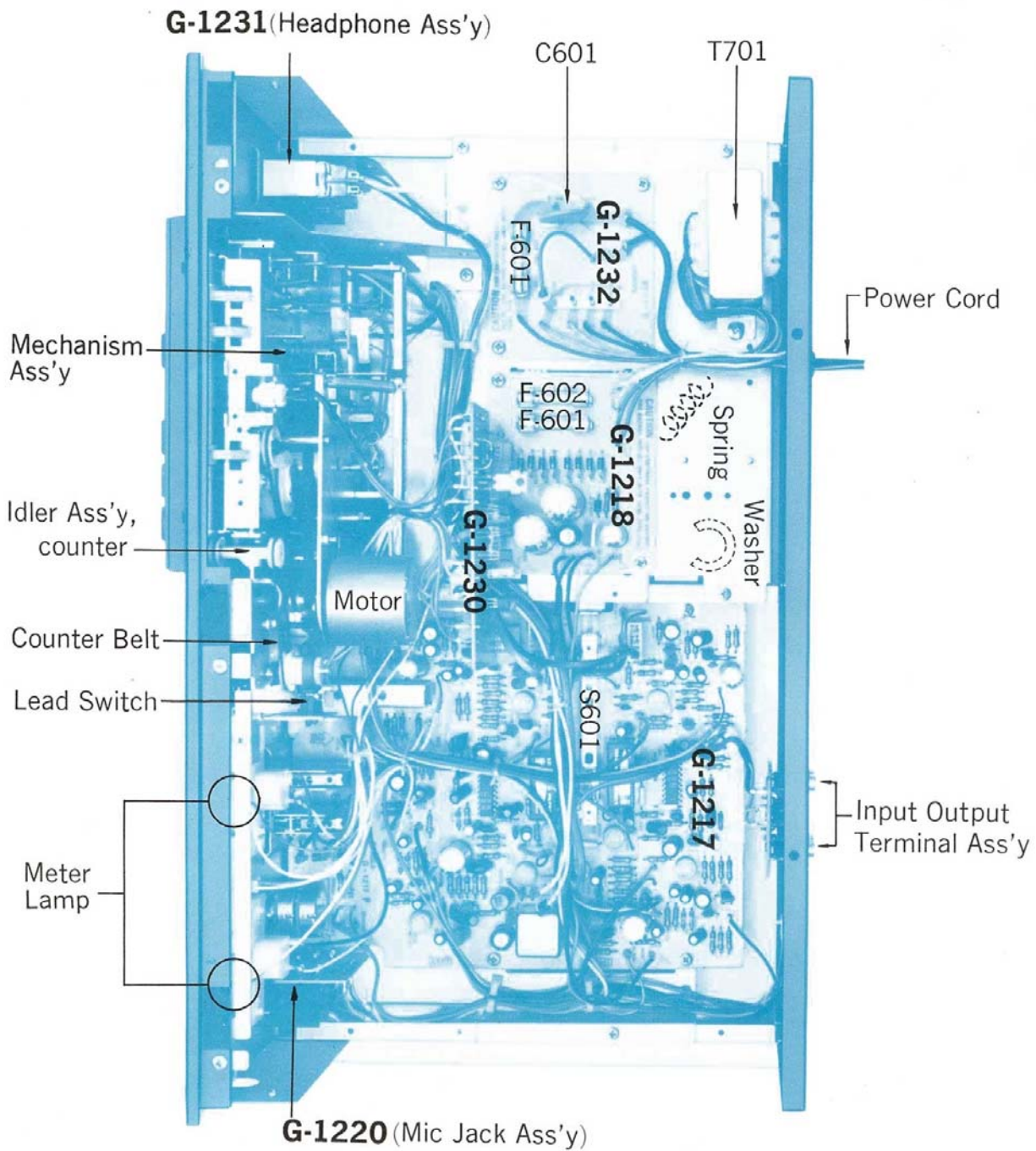

## Parts List

Parts No.	Stock No.	Description
C 601	0659801	0.01 $\mu$ F 150V C.C.
S 601	1110340	Slide Switch, rec-play
F 01	0432210	0.5A 250V
F 02	0432230	1.5A 250V
F 601	0432210	0.5A 250V Power Fuse
PL 701, 2	0400570	12V 75 mA VU Meter Light Ass'y
T 701	4002440	Power Transformer
	5109929	WT Type Screw, 4 x 8
	3800010	Power Cord
	3910600	Cord Stopper
	7710100	Input-Output Terminal
	7690301	G-1220 Mic Jack Circuit Board
	7690311	G-1231 Headphone Jack Circuit Board
	6500780	Spring

Parts No.	Stock No.	Description
	4320530	Motor
	5500540	Rubber, motor
	5107911	BSA Type Screw, M2.6 x 7
	5120121	P Type Washer, 2.6 $\phi$
	7060220	Motor Pulley
	5105502	SC Type Screw, M2 x 3
	5430130	Tape Counter Ass'y
	0400610	Counter Lamp 8V 65 mA
	1190350	Lead Switch
	6030220	Counter Belt (B)
	7060250	Counter Idler Ass'y
	7160100	Mechanism Ass'y (SC-1100)
	7160110	Mechanism Ass'y (SC-1110)



Disassembly of the Mechanism Ass'y

- ① ~ ③⑩
- ③① ~ ⑥⑩
- ⑥① ~ ⑨⑩
- ⑨① ~ ⑨⑦

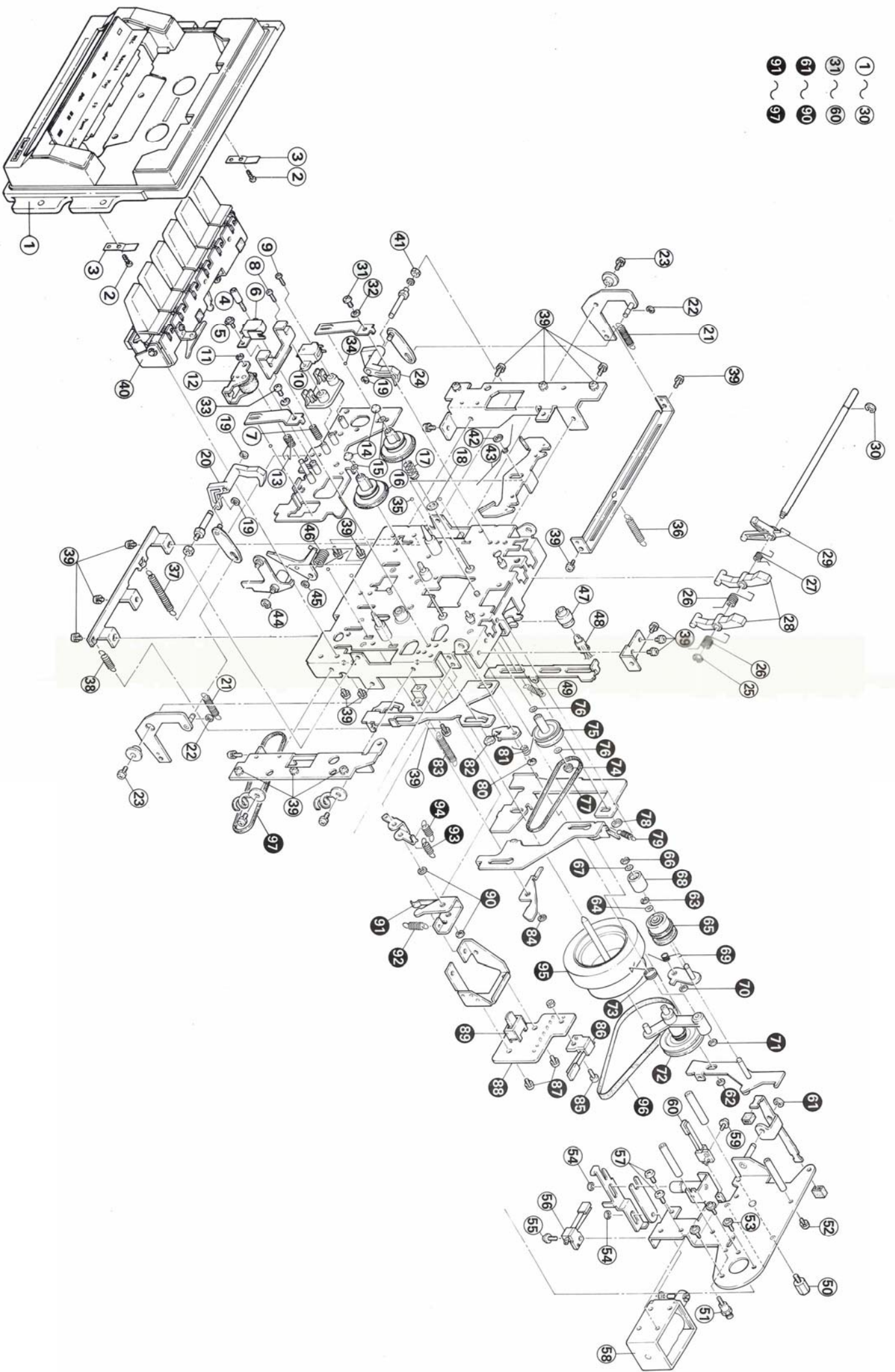



**Parts List**

Parts No.	Stock No.	Description	Parts No.	Stock No.	Description
1	7010150	Mechanism Cover	49	6901080	Spring, rec lever rod
2	5103502	P Type Screw, M2 x 6	50	5160310	Hex. Screw, M2.6
3	6400150	Plate Spring	51	5160330	Hex. Screw,
4	5160350	SS Type Screw, head adjustment	52	5107812	BSA Type Screw, M2.6 x 6
5	5103004	P Type Screw, M2 x 6	53	{ 5107911	P Type Screw, M2.6 x 7
6	4536020	REC/P.B Head	53	{ 5120121	P Type Washer, 2.6φ
7	6901100	Spring, head adjustment	54	5151011	E Type Washer, 2.5φ
8	5103044	P Type Screw, M2 x 8	55	5109920	W Type Screw, M2.6 x 5
9	5103004	P Type Screw, M2 x 6	56	1190360	Leaf Switch, pause
10	{ 4526010	Erase Head	57	5103042	B Type Screw, M3 x 5
	{ 4526020		58	4340160	Plunger Solenoid
11	5151002	E Type Washer, 2φ	59	5109920	W Type Screw, M2.6 x 5
12	7060160	Pinch Roller Arm Ass'y	60	1190560	Leaf Switch, FF
13	6901180	Spring, pinch roller	61	5151005	E Type Washer, 3.2φ
14	5370090	Cap	62	5151011	E Type Washer, 2.5φ
15	5180380	P Type Washer, 1.8φ	63	5151002	E Type Washer, 2φ
16	7150080	Reel Hub (B) Ass'y	64	5180410	P Type Washer, 2.5φ
17	6901340	Spring, back tension	65	7160170	Idler (A) Ass'y
18	5180490	P Type Washer, 6.2φ	66	5151001	E Type Washer, 1.5φ
19	5151011	E Type Washer, 2.5φ	67	5180430	P Type Washer, 2.1φ
20	5260390	Right Nail, cassette half cramper	68	7060180	Idler (B) Ass'y
21	6901440	Spring, nail	69	6901200	Spring, idler (B) arm
22	5151002	E Type Washer, 2φ	70	5151002	E Type Washer, 2φ
23	5107812	BSA Type Screw, M2.6 x 6	71	5151011	E Type Washer, 2.5φ
24	5260400	Left Nail, cassette half cramper	72	7060240	Tension Arm Ass'y
25	5151011	E Type Washer, 2.5φ	73	6901350	Spring, roller arm
26	6901420	Spring, upper nail	74	5370090	Cap
27	6901430	Spring, rec nail	75	7060200	Idler Ass'y
28	6500950	Upper Nail, cassette holder	76	5180420	P Type Washer, 1.6φ
29	6500960	Rec Prevention Nail	77	6030140	Tension Belt
30	5151004	E Type Washer, 3φ	78	5151011	E Type Washer, 2.5φ
31	5103022	P Type Screw, M2.6 x 4	79	6901130	Spring, FF Lever
32	5121320	S Type Washer, 2.6φ	80	5151011	E Type Washer, 2.5φ
33	5103023	P Type Screw, M2.6 x 5	81	6901160	Spring, pause rock plate
34	6540040	Steel Ball 2.5φ	82	5160300	Nut, M2.6
35	6540030	Steel Ball 2φ	83	6901370	Spring, plunger extraction
36	6901450	Spring, arm bar	84	5151011	E Type Washer, 2.5φ
37	6901120	Spring, brake lever rod	85	5103025	P Type Screw, M2.6 x 8
38	6901190	Spring, pause lever rod	86	1190550	Leaf Switch, motor
39	5107811	BSA Type Screw, M2.6 x 4	87	5107812	BSA Type Screw, M2.6 x 6
40	{ 7050110	Control Button Ass'y (SC-1100)	88	7690530	Mute Circuit Board Ass'y
	{ 7050130		89	1110370	Slide Switch, mute
41	5110241	Hex. Nut, M3	90	5151002	E Type Washer, 2φ
42	5151011	E Type Washer, 2.5φ	91	6500790	Plate Spring Lever, mute
43	6901090	Spring, brake lever	92	6901460	Spring, mute
44	5151004	E Type Washer, 3φ	93	6901500	Spring, REWIND lever
45	5151011	E Type Washer, 2.5φ	94	6901170	Spring, FR lever
46	6901470	Spring, rec arm	95	7040200	Flywheel Ass'y
47	5600010	Lamp Tube	96	6030130	Capstan Belt
48	0400630	Lamp, cassette half 12V 100 mA	97	6030160	Counter Belt (B).

**Abbreviations**

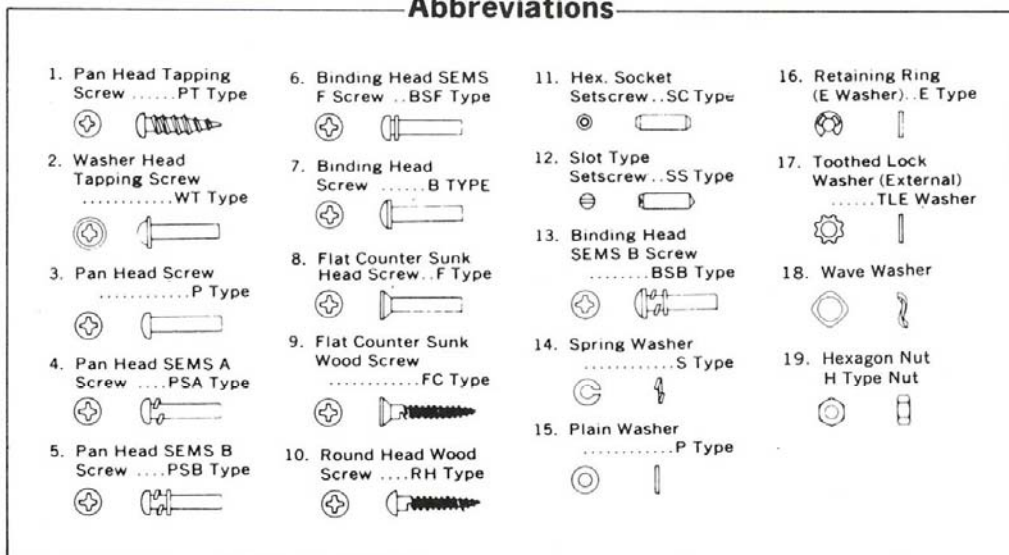

# 5. OPERATION OF MECHANISM

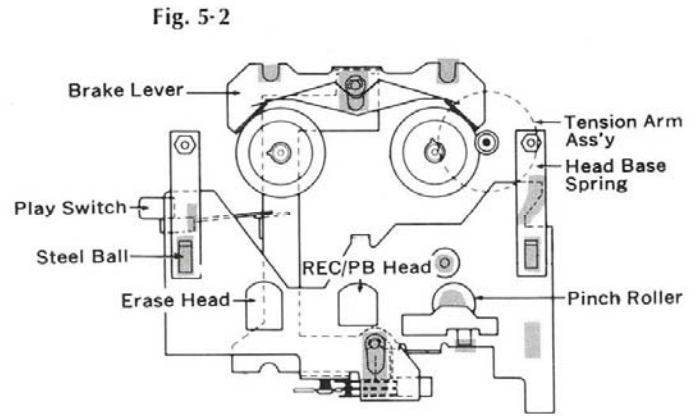
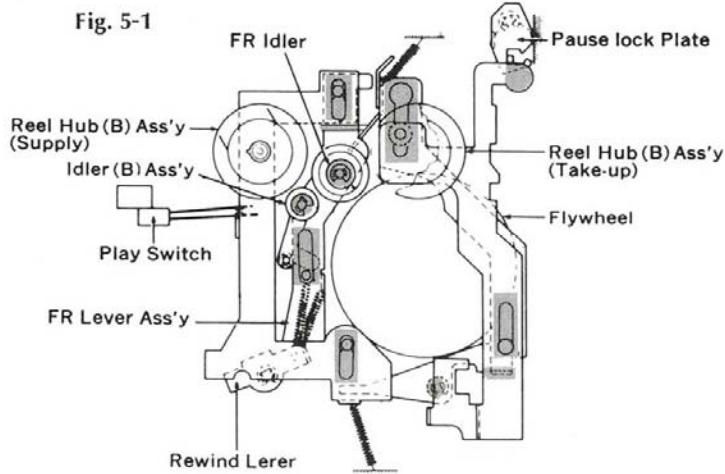

## 1) Driving Mechanism (See Fig. 5-3)

Motor begins to rotate by pushing the REWIND, PLAY and FF button. The Driving Motor is electronically controlled DC Motor. Driving Torque is transmitted to Take-up Pulley by Motor Pulley and Capstan Belt through Flywheel. They are always rotating when the cassette tape is running.

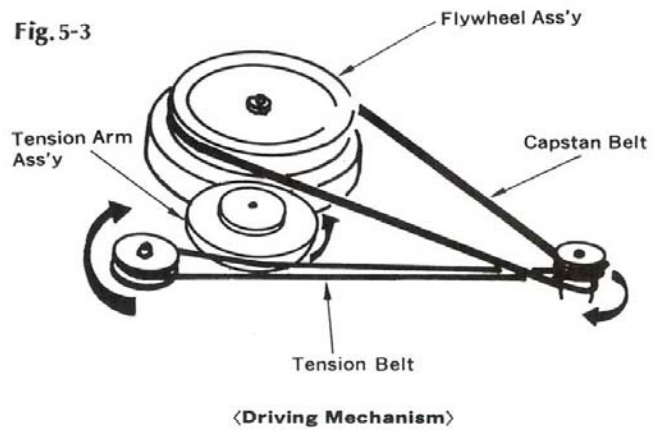

## 2) Forward Mode (See Fig. 5-4, 5-5, & 5-6)

When the PLAY Button is pushed, the head base moves toward the Reel Hub. It makes the Take-up Pulley Shaft bear against the Reel Hub. At the same time, the Brake is released by Brake Lever and Pinch Roller bears against the Capstan Pulley through tape. In accordance with the above, cassette tape gets constant speed running.

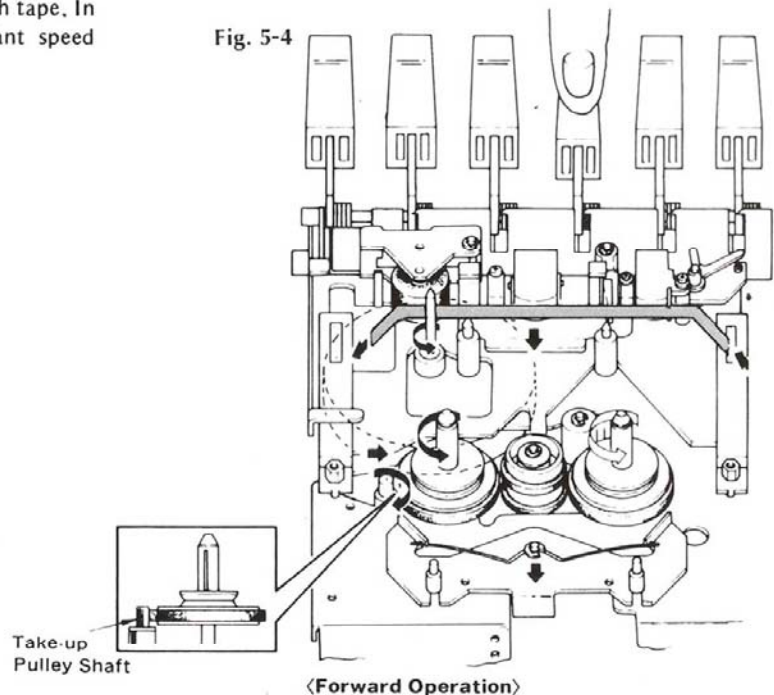



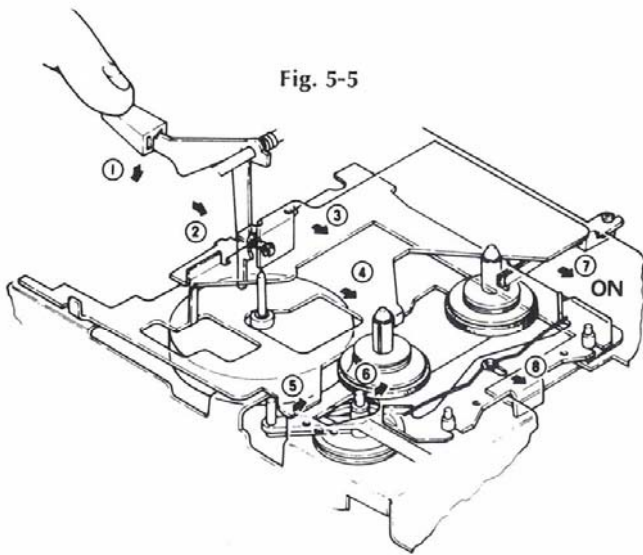

Fig. 5-5

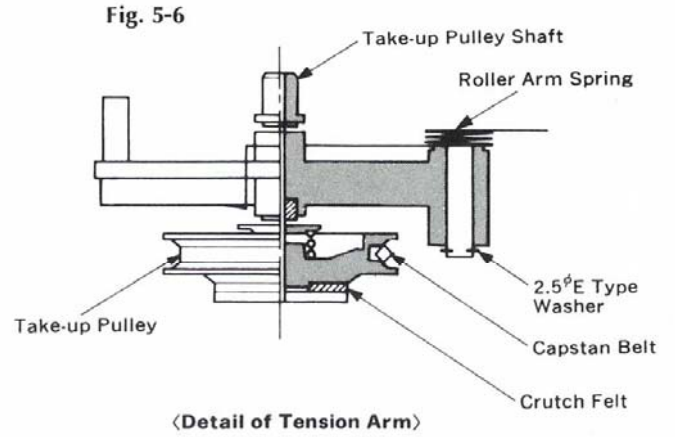

Fig. 5-6

<Detail of Tension Arm>

### 3) Fast Forward & Rewind Operation (See Fig. 5-7, 5-8, 5-9, 5-10 & 5-11)

When the FF Button is pushed, the FR Idler bears against the Flywheel and Reel hub. When the REWIND button is pushed, the above Mechanism is operated through REWIND Idler between FR Idler and Reel hub. The take-up torque in FF MODE is transmitted from Flywheel next FR Idler to Reel hub and REWIND torque is transmitted from Flywheel next FR Idler and REWIND Idler to Reel hub. Abnormal torque occurred by tape starting, tape stopping or other causes is absorbed by slipping of felt around FR Idler.

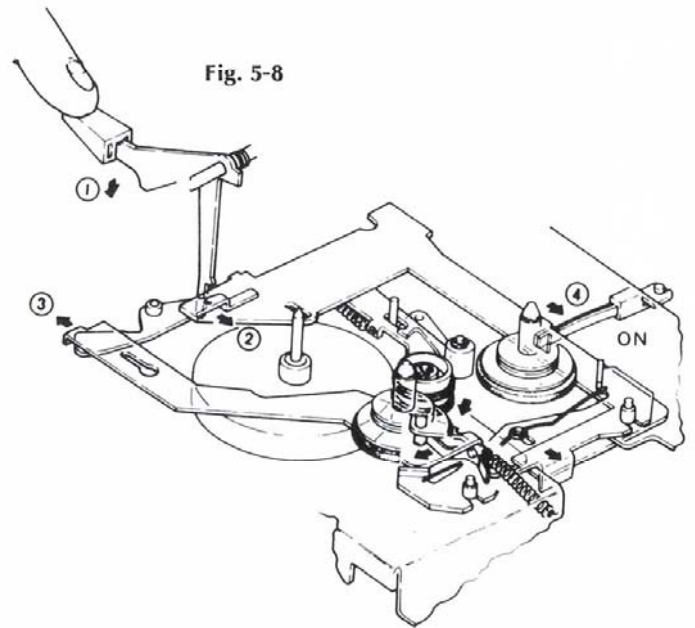

Fig. 5-8

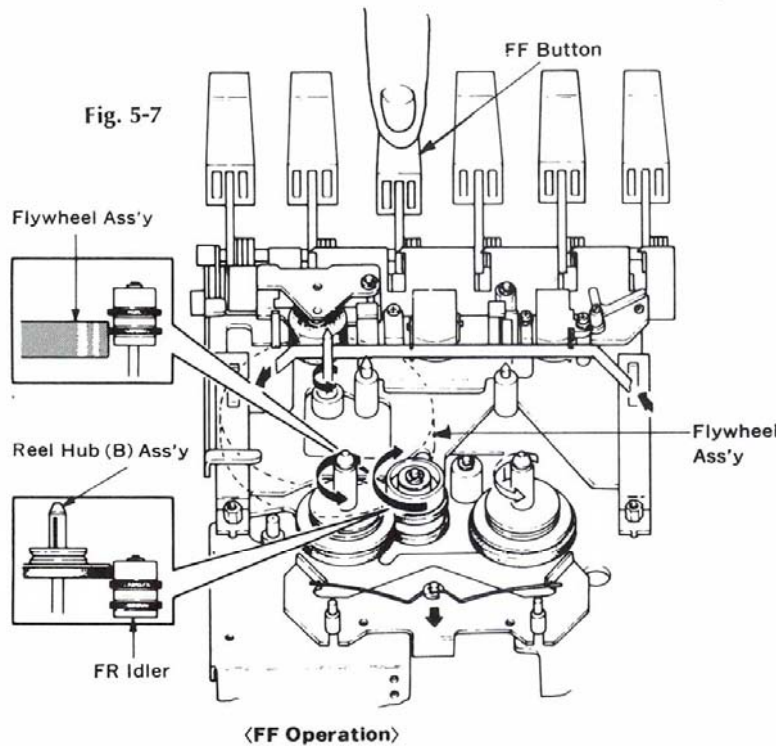

Fig. 5-7

<FF Operation>

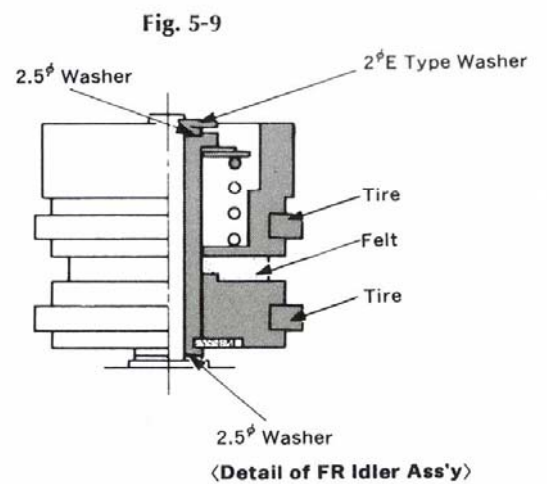
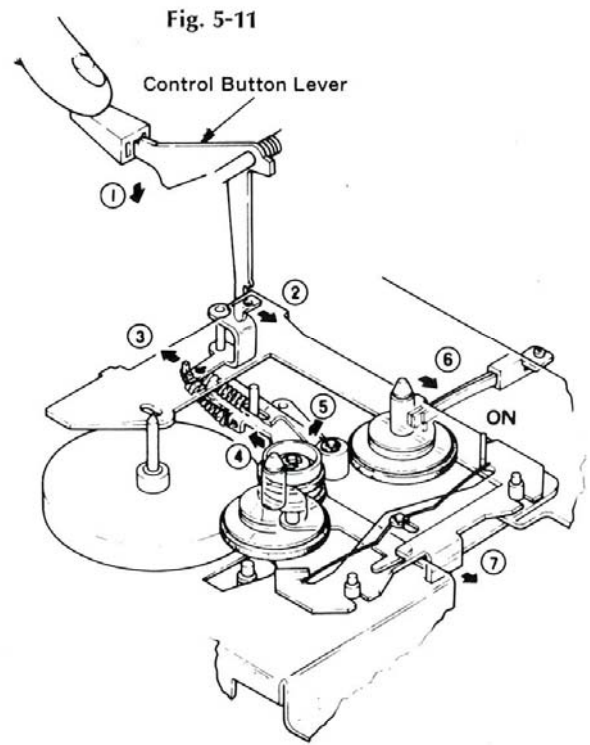
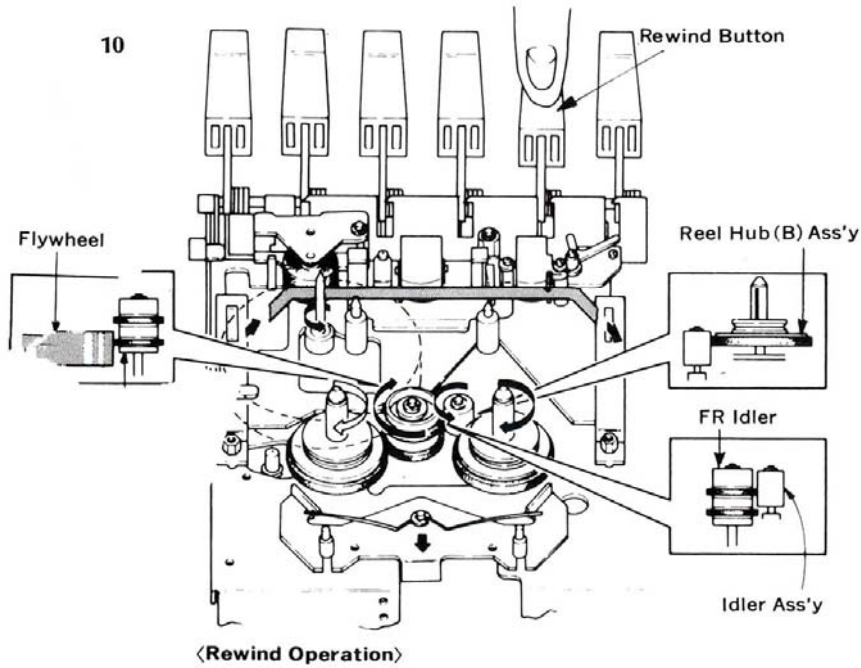

Fig. 5-9

<Detail of FR Idler Ass'y>





### e Mode (See Fig. 5-12)

Button is only operated in PLAY or REC MODE. When REVERSE Button is pushed, the Pinch Roller is disengaged from the Drive shaft and Take-up Pulley shaft is disengaged from the Drive shaft. It stops tape running.

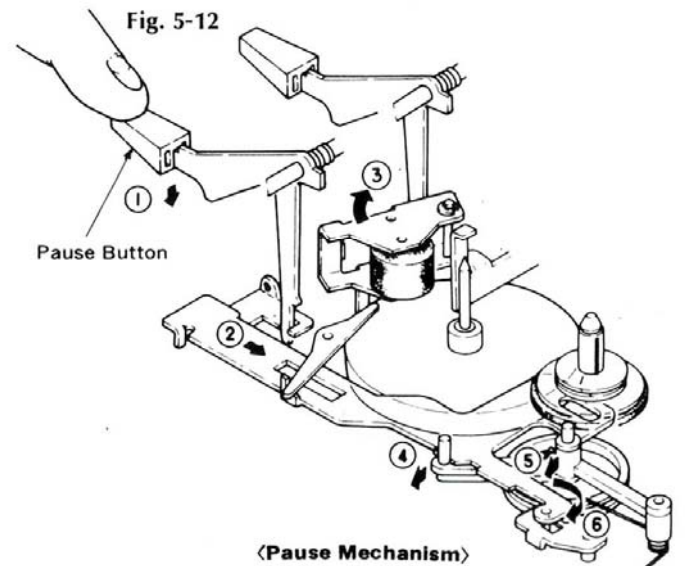

### 5) REC Mode

Tape transport mechanism is same as that of PLAY MODE operation. A cassette has "tabs" on the side opposite to that exposing the bare tape. If they are broken off, the cassette will prevent the depression of RECORD Button. When the Record Button and the PLAY Button are pushed, the slide switch on G-1217 main circuit board is changed from PLAY MODE to REC MODE.



## 7. OPERATION OF LEAD-IN & AUTOMATIC SHUT-OFF CIRCUIT

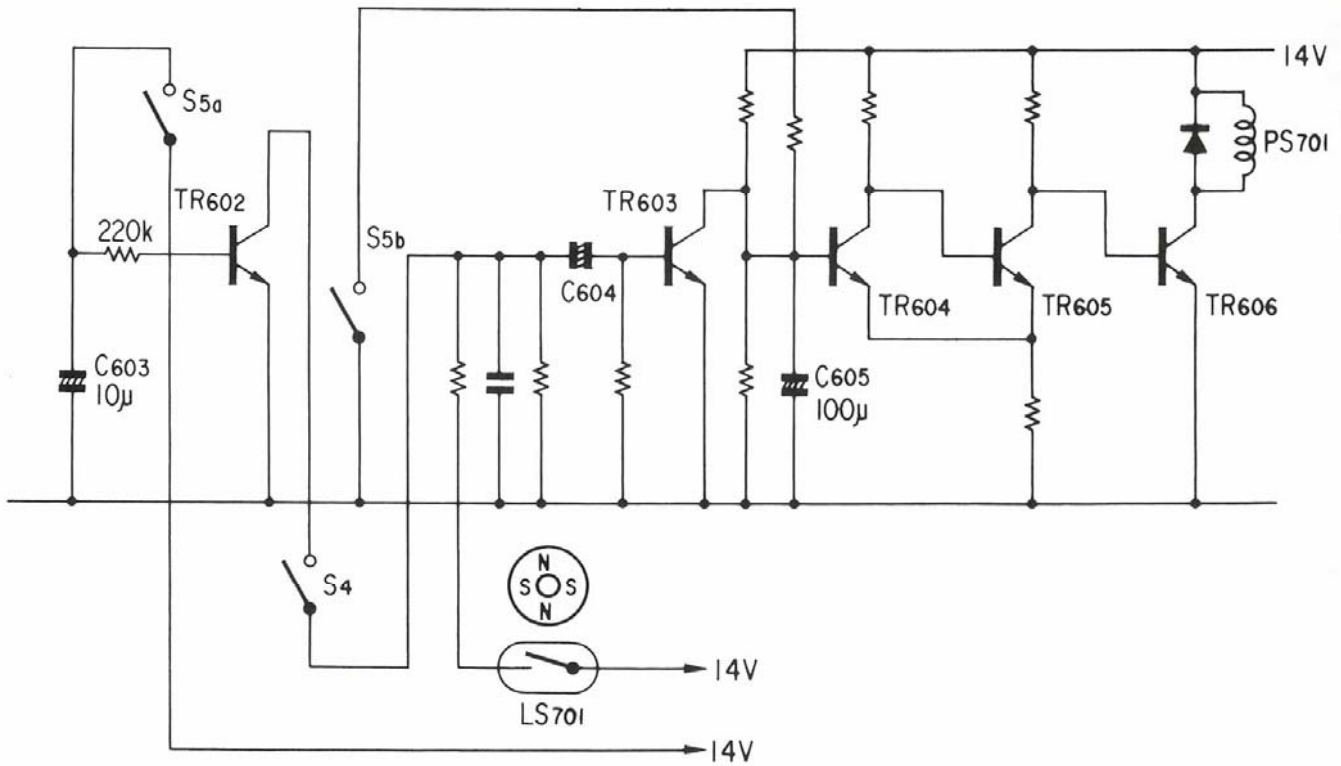

### ◇Operation of Automatic Shut-off Circuit

1. While the tape is running, the lead switch (LS701) repeats turning on and off, so that TR603 also repeats turning on and off, and charging-current is always flowing through the capacitor (C605).  
As a result, TR604 is OFF, TR605 is ON, TR606 is OFF, so that the solenoid does not function.
2. When the tape running is stopped, the lead switch stops turning on and off, so that bias voltage of TR603 is not supplied and TR603 turns OFF.  
After TR603 turns off, TR604 is ON, TR605 is OFF, and TR606 is ON, so that the solenoid begins functioning, by collector current of TR606 as automatic shut-off system.

### ◇Operation of Lead-in Circuit

1. When the lead-in switch (S5a, b) is turned on, the capacitor (C605) discharges and TR602 becomes ON for a while by the current charged in the capacitor (C603).
2. When the FF switch (S4) turns on, signal from lead switch goes to chassis (ground) through the TR602
3. For a few second (while the leader-tape is running), charging-current flows through the capacitor (C605).  
After the capacitor is charged, TR604 is ON, TR605 is OFF and TR606 is ON, so that the solenoid functions as lead-in system by collector current of TR606.



## 8. PACKING LIST

Parts No.	Stock No.	Description
1	9010100	Dust Cover Case
2	9116690	Vinyl Cover
	9120050	Polyethylene Sheet (SC-1100 only)
3	9030130	Stylofoam Packing (SC-1100)
	9030140	Stylofoam Packing (SC-1110)
4	9000382	Carton Case (SC-1100)
	9000391	Carton Case (SC-1110)
5	5996080	Curly Stopper

## 9. ACCESSORY PARTS LIST

Parts No.	Stock No.	Description
	9230170	Schematic Diagram
	9202790	Operating Instructions (SC-1100)
	9202800	Operating Instructions (SC-1110)
	9430030	Head Cleaning Pen
	3810280	Input-Output Cord
	5010080	Dust Cover
	5390080	Rack Mounting Adaptor (each) (SC-1110 only)

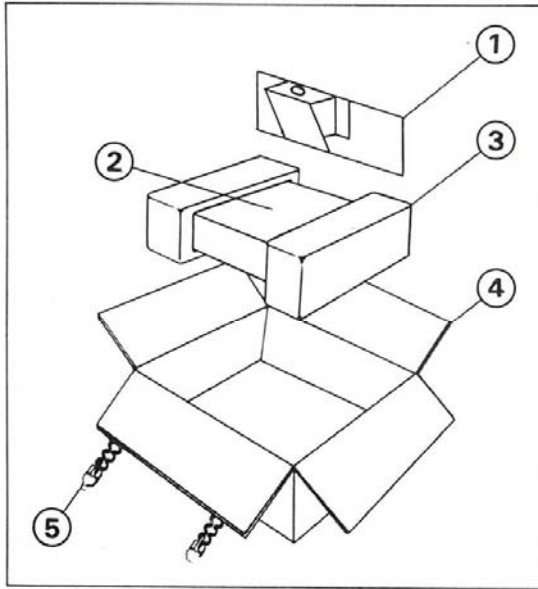

MEMO



SANSUI ELECTRONICS CORPORATION: 55-11 Queens Blvd. Woodside, N.Y. 11377 U.S.A.  
333 West Alondra Blvd. Gardena, California 90247 U.S.A.  
3036 Koapaka St. Honolulu, Hawaii 96819 U.S.A.

SANSUI AUDIO EUROPE N.V.: North Trade Bldg (9th floor) Noorderlaan 133-Bus 1,2030 Antwerp, Belgium  
SANSUI AUDIO EUROPE S.A.: Arabella center, 6 Frankfurt AM Main, Lyoner Strasse 44-48, West Germany

SANSUI ELECTRIC COMPANY LTD.: 14-1, Izumi 2-chome, Suginamiku, Tokyo 168 Japan PHONE: (03) 323-1111/TELEX:232-2076