

# SERVICE MANUAL

STEREO CASSETTE TAPE DECK

**SANSUI SC-2000**  
**SC-2002**  
**SC-3000**  
**SC-3003**



*Sansui*

SANSUI ELECTRIC CO., LTD.

This service manual is designed for service engineers to repair, adjust, maintain and order the replacement parts of the SC-2000, SC-2002, SC-3000, SC-3003 correctly.

When ordering the parts, use the stock number and parts name specifically referring to the Parts Location and Parts Lists.

For general usage and maintenance of the unit, please refer to the Operating Instructions attached with the unit.

## TABLE OF CONTENTS

<u>Section</u>	<u>Title</u>	<u>Page</u>
<b>1.</b>	<b>SPECIFICATIONS</b>	<b>2</b>
<b>2.</b>	<b>BLOCK DIAGRAM</b>	<b>2</b>
<b>3.</b>	<b>ADJUSTMENTS</b>	<b>3</b>
3-1.	Tape Speed Adjustment	3
3-2.	Playback Adjustment	3, 4
3-3.	Recording Adjustment	4
<b>4.</b>	<b>TROUBLESHOOTING CHART</b>	<b>5, 6</b>
<b>5.</b>	<b>PARTS LOCATIONS AND PARTS LIST</b>	<b>7</b>
5-1.	G-1197 Main Circuit Board	7, 8
5-2.	G-1198 Power Circuit Board	8
5-3.	G-1199 Shut-off Circuit Board	9
5-4.	G-1200 L.E.D. Circuit Board	9
5-5.	G-1201 Switch Circuit Board	9
5-6.	G-1211 L.E.D. Circuit Board	9
5-7.	G-1212 Switch Circuit Board	9
5-8.	Figures	9
<b>6.</b>	<b>DISASSEMBLY WITH EXPLODED VIEWS AND PARTS LIST</b>	<b>10</b>
6-1.	Hardware Nomenclature	10
6-2.	Disassembly of the Chassis Section	11, 12
6-3.	Disassembly of the Mechanism Ass'y	13, 14
	◇ Paking List	14
	◇ Accessory Parts List	14
<b>7.</b>	<b>OPERATION OF MECHANISM</b>	<b>15</b>
7-1.	Driving Mechanism	15
7-2.	Forward Mode	15, 16
7-3.	REC Mode	16
7-4.	Fast Forward and Rewind Operation	16
7-5.	Pause Mode	16
<b>8.</b>	<b>SCHEMATIC DIAGRAM</b>	<b>17</b>
8-1.	SC-2000, SC-2002 Schematic Diagram	17
8-2.	SC-3000, SC-3003 Schematic Diagram	18
<b>9.</b>	<b>REPLACEMENT OF MAIN PARTS</b>	<b>19</b>
9-1.	Replacement of Mechanism Ass'y	19
9-2.	Replacement of Cassette Ass'y	19
9-3.	Replacement of Cassette well and Cassette lid	19

# 1. SPECIFICATIONS

TRACK ..... 4-Track (2-Channel Stereo)  
 TAPE SPEED ..... 4.8cm/sec (1- $\frac{7}{8}$  ips)  
 HEADS ..... Record/Playback Hard  
                   Permalloy Head  
                   Erase Ferrite Head  
 MOTOR ..... Electronically Speed Controlled  
                   DC Motor  
 WOW AND FLUTTER .. Within 0.1% WRMS  
                           (SC-2000, SC-2002)  
                           Within 0.09% WRMS  
                           (SC-3000, SC-3003)  
 FAST WIND TIME ..... within 75 seconds (C-60)  
 FREQUENCY RESPONSE (Record/Playback)  
   Normal Tape (LH) ... 30 to 13,000Hz (35 to 11,000Hz  
                                    $\pm 3$ dB)  
   Chromium Tape ..... 30 to 15,000Hz (35 to 12,000Hz  
                                    $\pm 3$ dB) (SC-2000, SC-2002)  
                                   30 to 16,000Hz (35 to 13,000Hz  
                                    $\pm 3$ dB) (SC-3000, SC-3003)  
 SIGNAL TO NOISE RATIO (Record/Playback)  
   Chromium Tape (without Dolby Noise Reduction  
   Effect) ..... better than 50dB (weighted)  
   Dolby Noise Reduction Effect  
                   ..... better than 60dB (above 5kHz)

ERASURE FACTOR ..... more than 60dB at 1,000Hz  
 INPUT SENSITIVITY & IMPEDANCE (0 VU, 1,000Hz)  
   MIC-L, R ..... 0.5mV 600 $\Omega$ ~10k $\Omega$   
   LINE ..... 70mV 100k $\Omega$   
   DIN Connector Socket  
                   ..... 4.3mV 8k $\Omega$   
 OUTPUT LEVEL (0 VU, 1,000Hz)  
   LINE ..... 300mV  
   DIN Connector Socket  
                   ..... 300mV  
 HEADPHONES ..... 8 $\Omega$   
 BIAS FREQUENCY ..... 85kHz  
 POWER REQUIREMENTS  
   Voltage ..... 100, 120, 220, 240V 50/60Hz  
                   120V (Usable 110-130V)  
                   (For U.S.A. & Canada only)  
   Consumption ..... 12.5W (rated)  
 DIMENSIONS ..... (17- $\frac{3}{8}$ " W, 158mm  
                           (6- $\frac{1}{4}$ " H, 290mm (11- $\frac{7}{16}$ " D  
 WEIGHT ..... 8kg (17.6 lbs.) net  
                   10kg (22.0 lbs.) packed

† Dolby is a trademark of Dolby Laboratories, Inc.  
 \* Design and specification subject to change without notice for improvements.

# 2. BLOCK DIAGRAM

RECORDING OPERATION BLOCK DIAGRAM

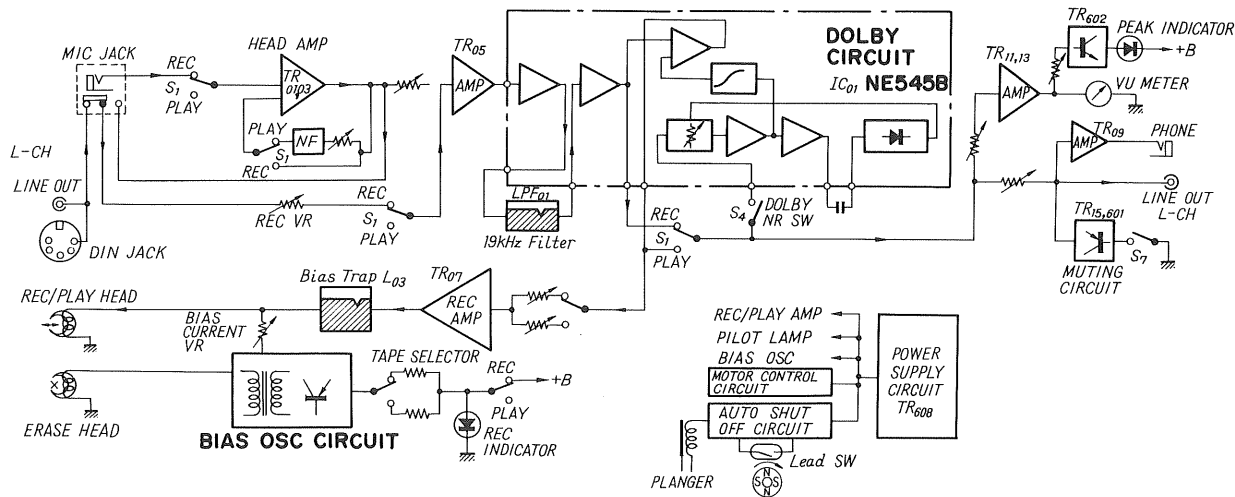

PLAYBACK OPERATION BLOCK DIAGRAM

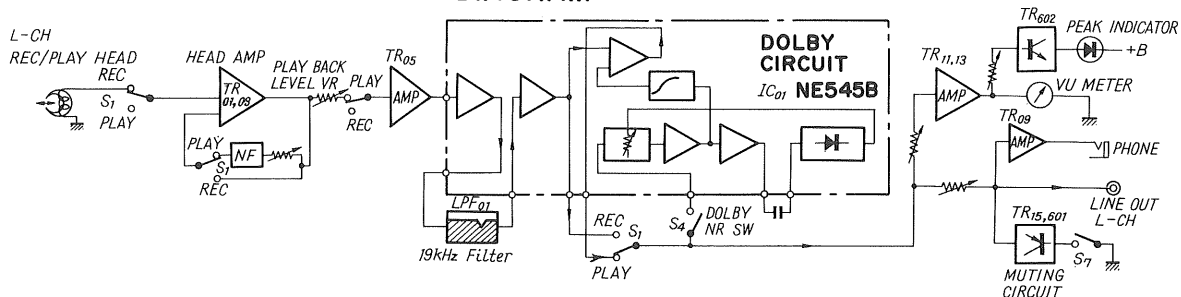

### 3. ADJUSTMENTS

\* The List of Sansui Test Tapes

Name of test tape	Recorded Frequency	Description
SCT-S3K	3kHz	Speed Check, Wow & Flutter Check
SCT-L400N	400Hz	Playback level adjustment and VU meter level adjustment
SCT-F1K	1kHz	High frequency equalization adjustment
SCT-F10KN	10kHz	REC/PB head adjustment
SCT-FCB6 (NORMAL)		Recording bias adjustment
SCT-FCR (CHROMIUM)		REC/PB level adjustment
		Frequency response check
SCT-F40	40Hz	Playback frequency reponse check

#### 3-1. Tape Speed Adjustment

- Note: (1) Use Sansui Test Tape, SCT-S3K (3kHz signals are recorded on the tape).  
 (2) Connections

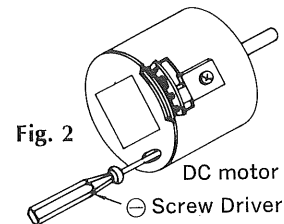
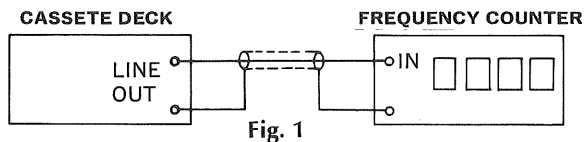

SUBJECT	INPUT SIGNAL	CHECK POINT	SETTING	ADJUST FOR	ADJUST	DESCRIPTION
TAPE SPEED ADJ.	Test Tape SCT-S3K	LINE OUT	Depress the PLAY button and playback the Test Tape, SCT-S3K	3000Hz $\pm 2\%$	If not, turn semi-variable resistor as Fig. 2 until 3000Hz $\pm 2\%$ is obtained.	Use small screw driver.

#### 3-2. Playback Adjustment

- Note: (1) Before this adjustment, clean REC/P.B head surface.  
 (2) Demagnetize the head by demagnetizer, if necessary.  
 (3) For this adjustment, use Sansui Test Tape, SCT-F10KN, SCT-L400N and SCT-F1K.  
 (4) Set the OUTPUT LEVEL volume to maximum and the Dolby switch to OUT.  
 (5) Connections

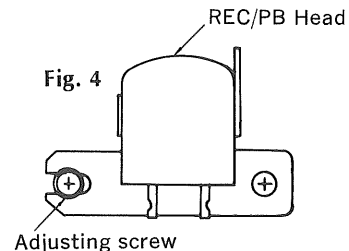
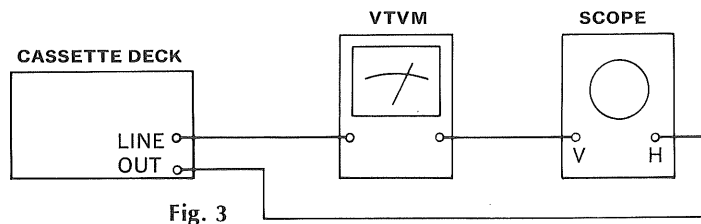

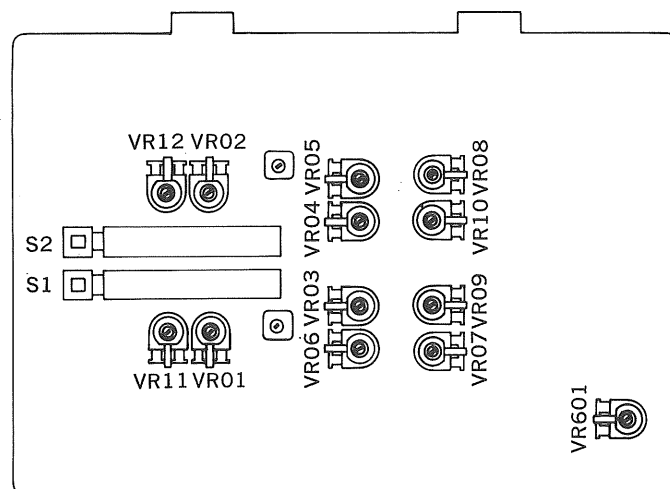

Fig. 5 G-1197 Main Circuit Board

SUBJECT	INPUT SIGNAL	CHECK POINT	SETTING	ADJUST FOR	DESCRIPTION
REC/PB Head Adj.	SCT-FIOKN	LINE OUT	Depress the PLAY button and playback the test Tape, SCT-FIOKN	Adjust the azimuth adjusting screw in Fig. 4 and tape guide for the maximum reading on the VTVM on both channels.	After this adjustment, lock the screw with paint.
Playback Level Adj.	SCT-L400N	LINE OUT	Depress the PLAY button and playback the Test Tape, SCT-L400N	Adjust VR01 (20kΩ) for L-CH and VR02 (20kΩ) for R-CH for the reading of 378mV ±2dB on VTVM (See Fig. 5)	Set same level (378mV ±20dB) on both channels
VU meter level Adj.				Adjust VR07 (10kΩ) for L-CH and VR08 (10kΩ) for R-CH for the reading of +2VU ±1VU on VTVM (See Fig. 5).	
High frequency Equalization Adj.	SCT-FIK and SCT-F10KN	LINE OUT	Playback Test Tapes, SCT-FIK and SCT-FIOKN	Adjust VR11 (50kΩ) for L-CH and VR12 (50kΩ) for R-CH so that the difference of output levels from SCT-FIK and SCT-FIOKN is within +3dB ~ -5dB.	In playback of SCT-10KN, set the TAPE SELECTOR to CHROMIUM, then confirm the indication on V.T.V.M drops down approximately -4dB.

### 3-3. Recording Adjustments

(1) Connection

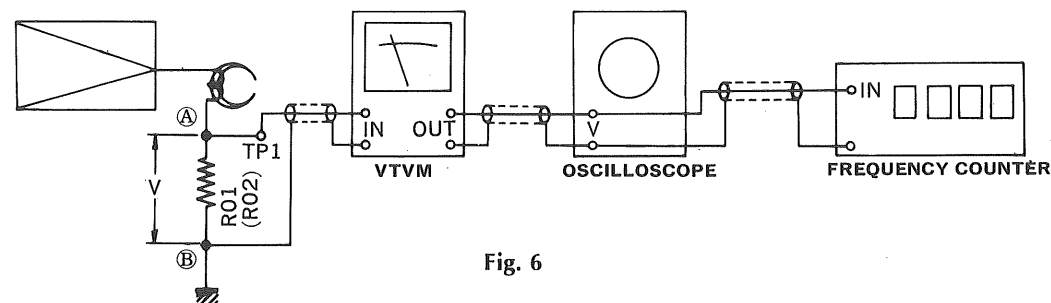

Fig. 6

SUBJECT	INPUT SIGNAL	CHECK POINT	SETTING	ADJUST	DESCRIPTION
Recording bias Adj.	Use recording LH tape.	Voltage value between (A) and (B) of R01 & R02 (See Fig. 6)	Depress REC and PLAY buttons.	Set TAPE SELECTOR to NORMAL (LH) position.	Adjust VR01 (20kΩ) for L-CH and VR02 (20kΩ) for R-CH for the reading of 4mV between (A) and (B) in Fig. 6 on both channels.
	Use recording CHROMIUM tape.		Set TAPE SELECTOR to CHROMIUM position.		
Bias Frequency Adj.		Same as above	Set TAPE SELECTOR to NORMAL or CHROMIUM position		Confirm that frequency counter shows 85kHz ±10kHz.

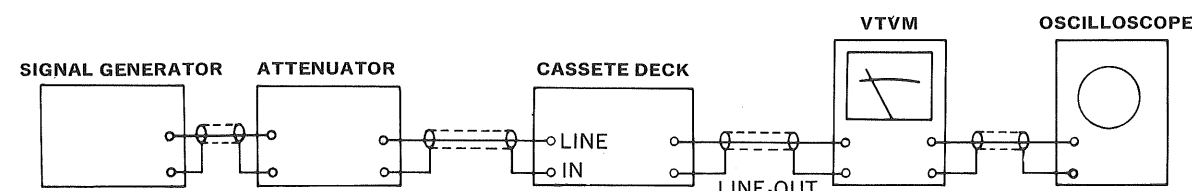

Fig. 7

SUBJECT	INPUT SIGNAL	CHECK POINT	SETTING	ADJUST FOR	DESCRIPTION
REC/P.B Level Adj. (NORMAL)	Use recording LH tape SCT-FCB6.  Feed 1kHz, 7mV (-20dB) from S.G. into LINE IN.	LINE OUT	Set TAPE SELECTOR to NORMAL (LH) position. 1. Depress PAUSE, PLAY and REC button. 2. Adjust the MIC/LINE volume for obtaining 0dB on the VU meters 3. Push off the PAUSE button, then record the 1kHz signal. 4. Playback the 1kHz signal. 5. Confirm that the output levels on both channels are 300mV ±2dB on V.T.V.M.	1. If not, turn VR05(10kΩ) for L-CH and VR06 (10kΩ) for R-CH until output Level, 300mV ±2dB on both channels are obtained. 2. Repeat this REC/P.B. Level adj. until the indication on V.T.V.M. will be 300mV ±2dB.	
REC/P.B Level Adj. (CHROMIUM)	Use CHROMIUM tape SCT-FCR	LINE OUT	Set TAPE SELECTOR to CHROMIUM position.	1. Confirm that the output levels on both channels are 300mV ±2dB on V.T.V.M. If not, turn VR03 (20kΩ) for L-CH and VR04 (20kΩ) for R-CH until indication on V.T.V.M. will be 300mV ±2dB	
	Same as above		Same as above		
Frequency Response Adj. (NORMAL)	Feed 1kHz, 7mV (-20dB) and 10kHz; 7mV (-20dB) from S.G. in to LINE IN.	LINE OUT	Set TAPE SELECTOR to NORMAL position. 1. Record the 1kHz and 10kHz signals from S.G. 2. Playback the 1kHz and 10kHz signals, then confirm that the difference of output levels between 1kHz and 10kHz recorded are within 0dB against that of 1kHz.	1. If not, adjust VR09 (100kΩ) for L-CH and VR10 (100kΩ) for R-CH slightly until difference of output levels between 1kHz and 10kHz recorded are within 0dB against that of 1kHz.	As VR09 and VR10 are previously adjusted in step of Bias Adjustment, turn then slightly, if necessary.
Peak Indicator Lighting Adj.	Feed 1kHz, 140mV (+6dB) from S.G. in to LINE IN.	VU meter	Depress REC and PLAY button Confirm that the peak Indicator is continuously lit by +6dB input level.	If not, adjust VR601 until the indicator is lit by +6dB	

## 4. TROUBLESHOOTING CHART

### AMPLIFIER SECTION

#### 1. No Output Signal & Recording Impossible

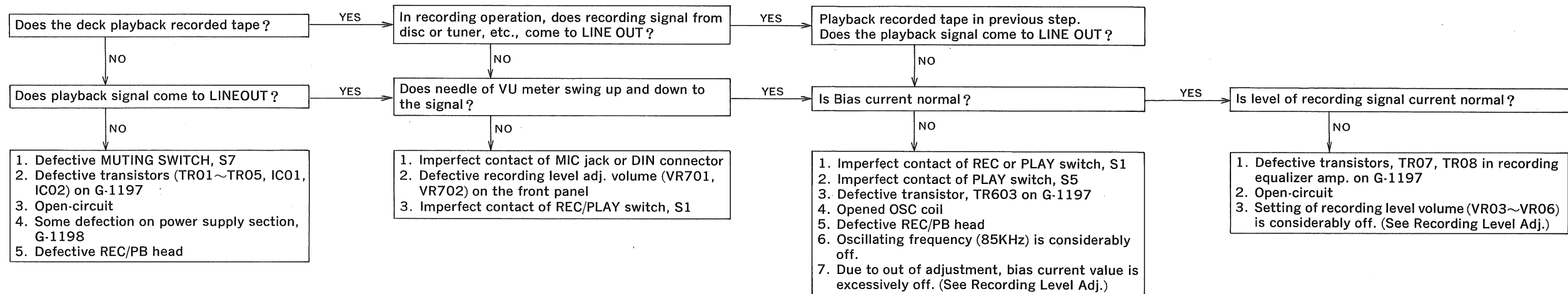

#### 2. Sound Distorted

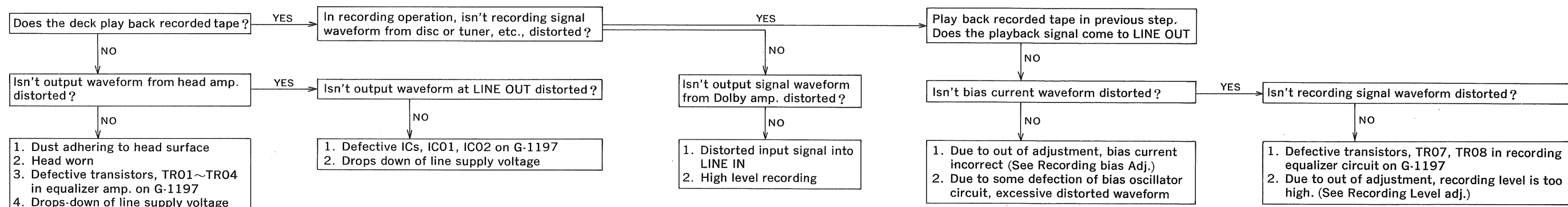

### SHUT-OFF CIRCUIT SECTION

#### 1. Automatic stop inoperative

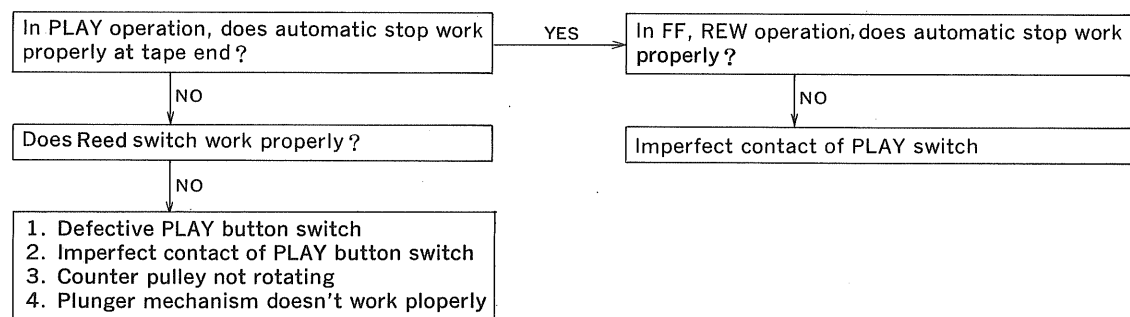

## TAPE TRANSPORT MECHANISM SECTION

### 1. No Tape Running or Tape Speed not Normal

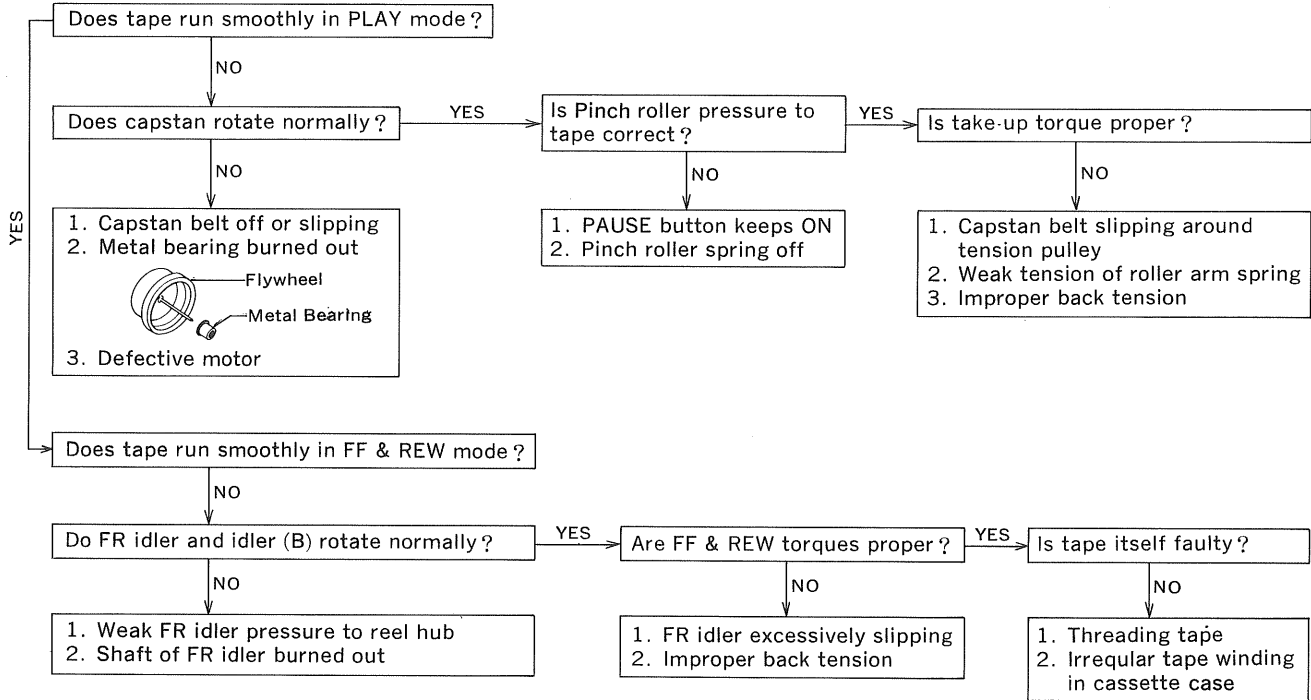

### 2. Abnormal Playback Sound

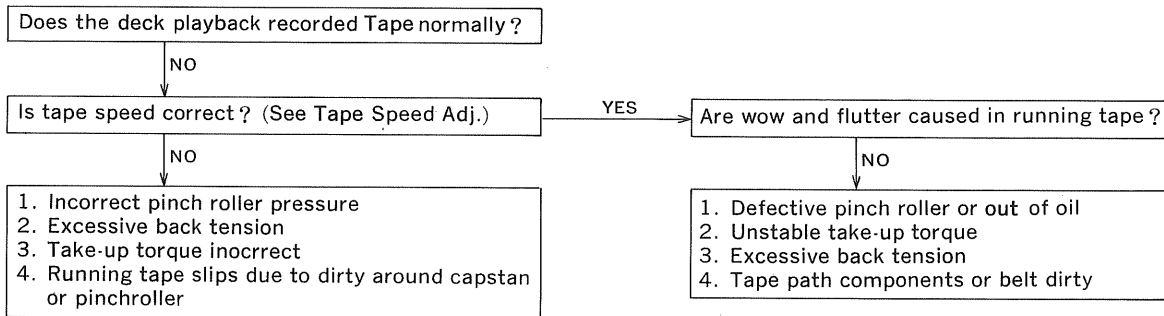

### 3. Each button inoperative

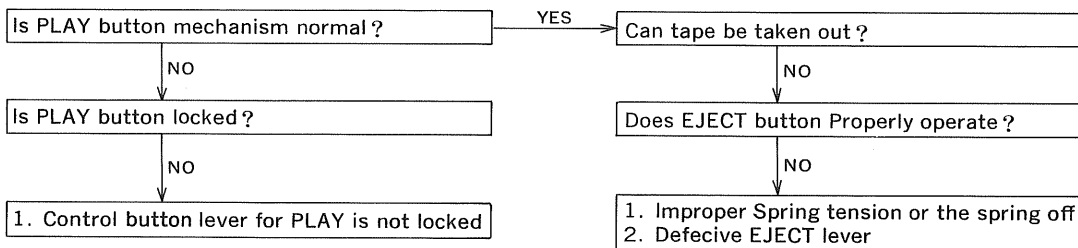

# 5. PARTS LOCATIONS AND PARTS LISTS

5-1. G-1197 Main Circuit Board (Stock No. 7990270 Complete Circuit Board... SC-2000, SC-2002)  
 (Stock No. 7590191 Complete Circuit Board... SC-3000, SC-3003)  
 Conductor side

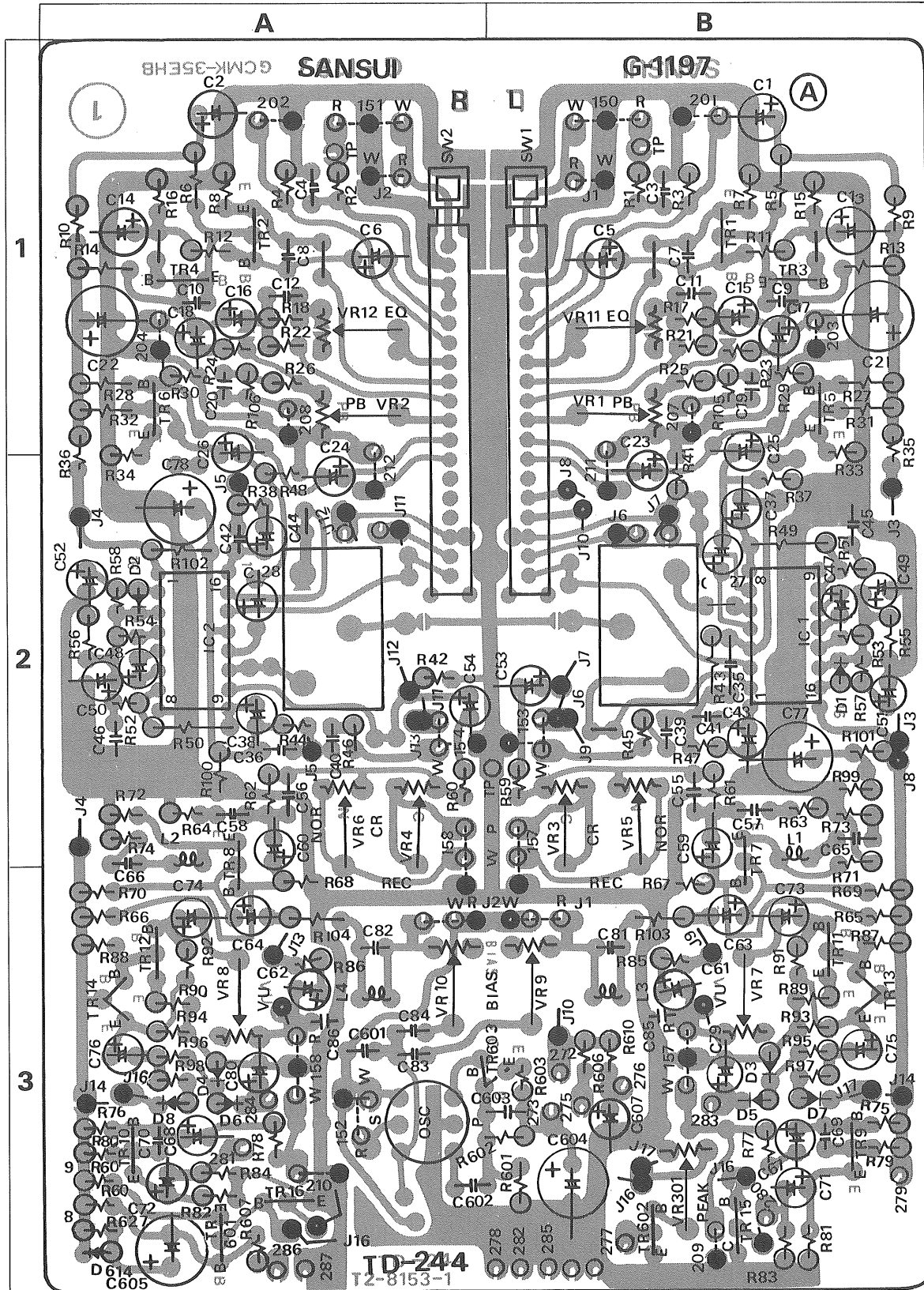





5-3. G-1199 Shut-off Circuit Board (Stock No. 7690200 Complete Circuit Board)

Conductor Side

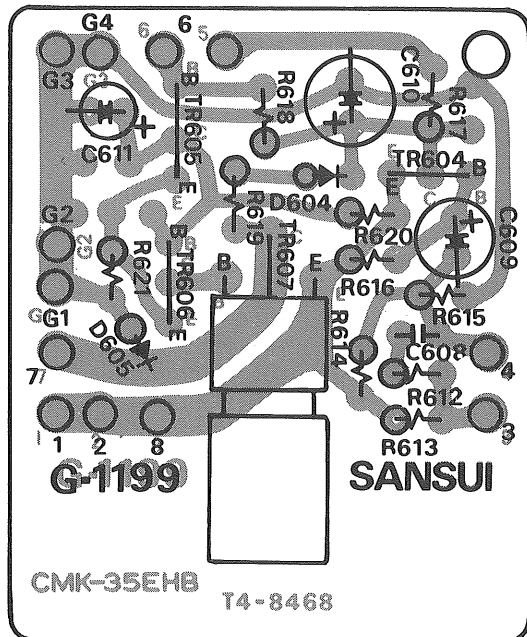

Parts List

Parts No.	Stock No.	Description
TR604	0300810	2SA564 (R)
TR605	0305542	2SC828 (R)
TR606	0305542	2SC828 (R)
TR607	0300820	2SA699 (R)
		Transistor
D604	0311510	TD960016-1
D605	0311500	1N4002
		Diode
C608	0600106	0.001 $\mu$ F 50V M.C.
C609	0512220	22 $\mu$ F
C610	0519006	47 $\mu$ F 16V E.C.
C611	0512100	10 $\mu$ F
R612	0106221	220 $\Omega$
R613	0106332	3.3k $\Omega$
R614	0106153	15k $\Omega$
R615	0106332	3.3k $\Omega$
R616	0106332	3.3k $\Omega$
R617	0106332	3.3k $\Omega$
R618	0106153	15k $\Omega$
R619	0106103	10k $\Omega$
R620	0106102	1k $\Omega$
R621	0106471	470 $\Omega$
		1/4 W C.R.

5-6. G-1211 L.E.D. Circuit Board (Stock No. 7690240 Complete Circuit Board) (SC-2000, SC-2002)

Conductor Side

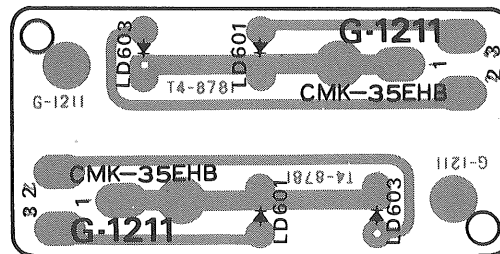

Parts List

Parts No.	Stock No.	Description
LD601	0319070	Light Emitted Diode, RECORD
LD603	0319080	Light Emitted Diode, DOLBY NR
	2420440	5P Connector

5-4. G-1200 L.E.D. Circuit Board (Stock No. 7690230 Complete Circuit Board) (SC-3000, SC-3003)

Conductor Side

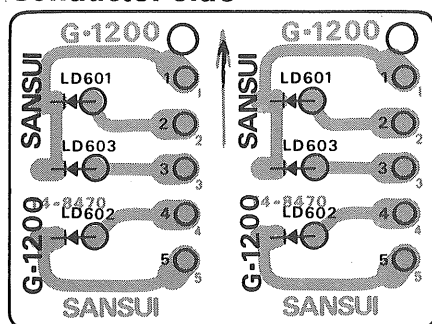

Parts List

Parts No.	Stock No.	Description
LD601	0319070	Light Emitted Diode Ass'y, RECORD
LD602	0319070	Light Emitted Diode Ass'y, PEAK
LD603	0319080	Light Emitted Diode Ass'y, DOLBY NR
	2420440	5P Connector

5-5. G-1201 Switch Circuit Board (Stock No. 7690210 Complete Circuit Board) (SC-3000, SC-3003)

Conductor Side

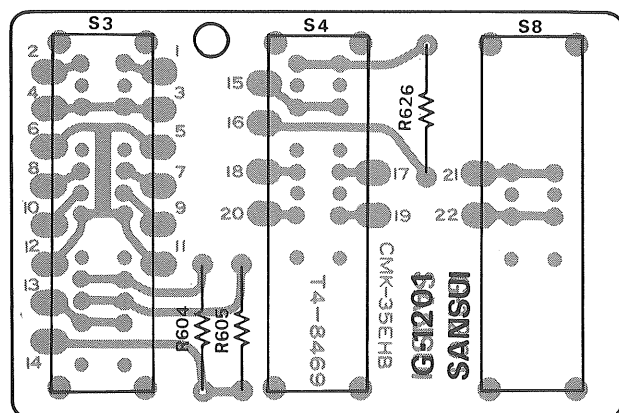

Parts List

Parts No.	Stock No.	Description
R604	0107820	82 $\Omega$
R605	0107391	390 $\Omega$
R626	0107102	1k $\Omega$
		1/4 W C.R.
S3	1171540	Slide Switch, TAPE SELECTOR
S4	1171550	Slide Switch, DOLBY NR
S8	1171560	Slide Switch, MEMORY

5-8. Figures













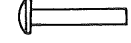



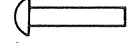

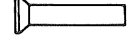

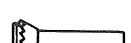

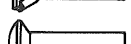

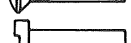

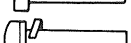

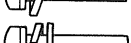

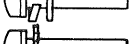

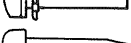

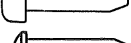

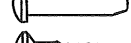

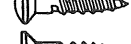



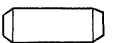



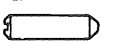

SEMICONDUCTORS	COMPLETE CIRCUIT BOARD	SEMICONDUCTORS	COMPLETE CIRCUIT BOARD
2SC1226 2SA699	 BCE	G-1198 G-1199	1N4002 TD96016-1 0A-90
2SA564 2SC828 2SC1327 2SC644	 ECB	G-1197 G-1199	MA1160A
2SB22	 ECB	G-1197	1S188
NE545B	 1 2 3 4 5 6 7 8	G-1197	

Abbreviations

C.R. : Carbon Resistor	BP.E.C.: Bi-Polar Electrolytic Capacitor
S.R. : Solid Resistor	C.C. : Ceramic Capacitor
Ce.R. : Cement Resistor	Mi.C. : Mica Capacitor
M.R. : Metallized Film Resistor	O.C. : Oil Capacitor
M.C. : Mylar Capacitor	P.C. : Polystyrene Capacitor
E.C. : Electrolytic Capacitor	T.C. : Tantalum Capacitor

# 6. DISASSEMBLY WITH EXPLODED VIEWS AND PARTS LIST

## 6-1. Hardware Nomenclature

	Name	Abbreviation	Type		
<b>SCREW</b>	Pan Head Screw	P			
	Binding Head Screw	B			
	Binding Head Screw (Dog Point)	BD			
	Round Head Screw	R			
	Flat Countersunk Head Screw	F			
	Flat Countersunk Head SEMS Screw (E-Type)	FSE			
	Oval Countersunk Head Screw	O			
	Flat Fillister Screw	FS			
	Binding Head SEMS Screw (A Type)	BSA			
	Binding Head SEMS Screw (B Type)	BSB			
	Binding Head SEMS Screw (C Type)	BSC			
	Pan Head Tapping Screw	PT			
	Binding Head Tapping Screw	BT			
	Oval Countersunk Wood Screw	OC			(JIS)
	Flat Countersunk Wood Screw	FC			(JIS)
Round Head Wood Screw	RH			(JIS)	
<b>SETSCREW</b>	Hex Socket Setscrew (Flat Point)	SF			
	Hex Socket Setscrew (Cone Point)	SC			
	Slot Type Setscrew	SS			
<b>WASHER</b>	Retaining Ring (E Washer)	E			
	Plane Washer	P			
	Spring Washer	S			
	Corrugated Washer	C			
	Toothed Lock Washer (Internal)	TLI			
Toothed Lock Washer (External)	TLE				

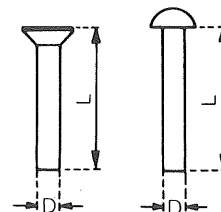
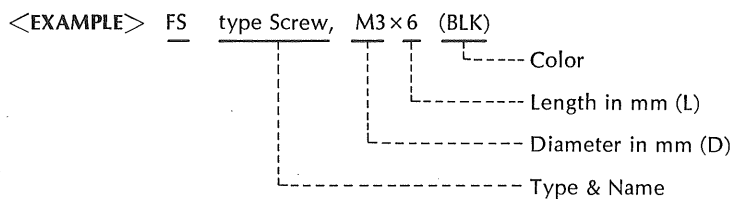

All screws conform to ISO standards, unless otherwise noted.

### 6-2. Disassembly of the Chassis Section

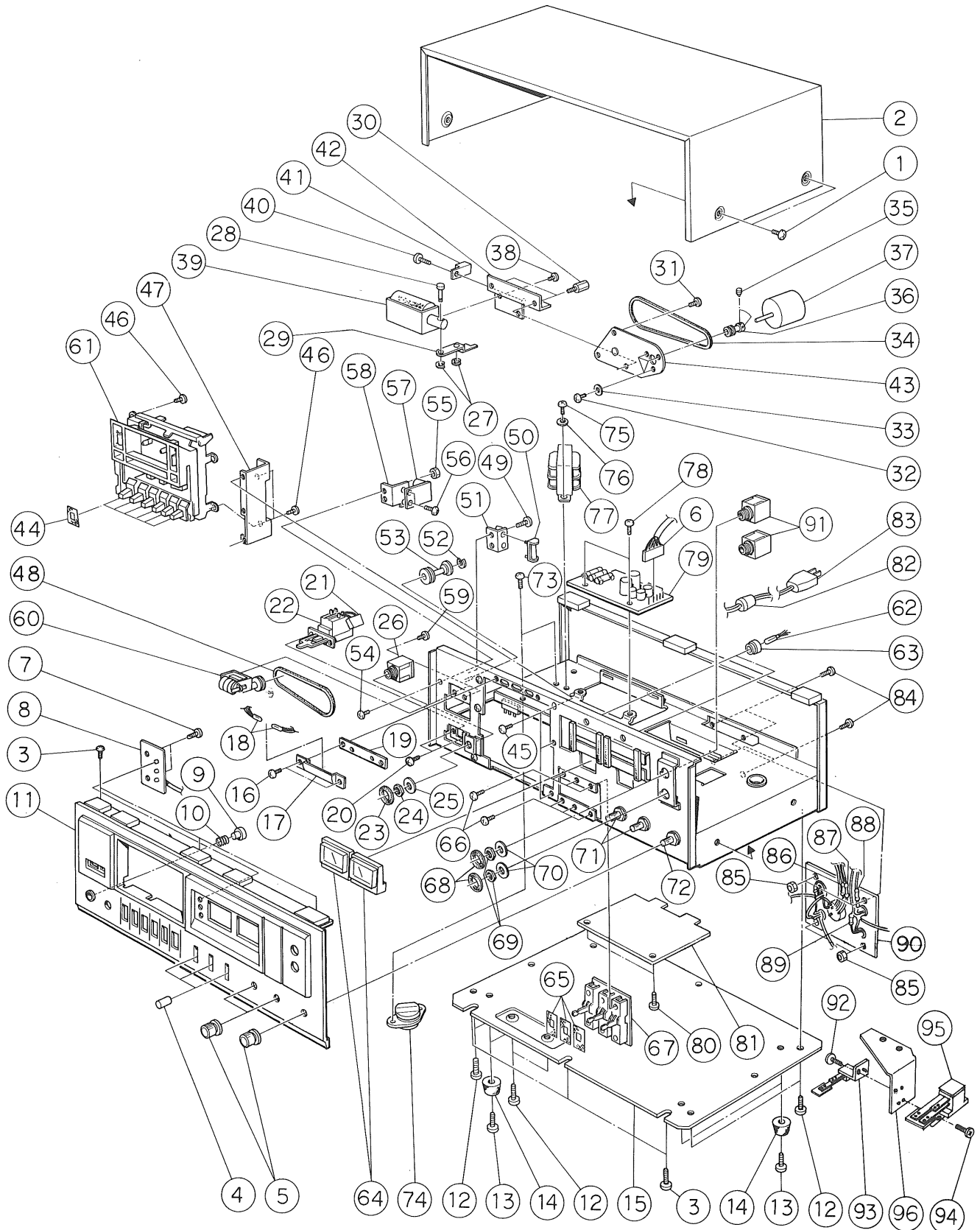

Parts List

Parts No.	Stock No.	Description	Parts No.	Stock No.	Description
1	5101162	B Type Screw, M4 × 8	55	5110241	Hex. Nut, M3
2	5000010	Metal Bonnet	56	5109911	B Type Screw, M3 × 6
3	5109122	BT Type Screw, M3 × 8	57	7690200	G-1199 Shut-off Circuit Board
4	7106130	C Type Knob, lever switch	58		Bracket, shut-off Circuit Board
5	5318410	TY (S-47) Type Knob, level control	59	5101042	B Type Screw, M3 × 5
6	2420440	5P Connector	60	{ 5430070	Tape Counter . . . . . SC-3000, 3003
7	5103521	BT Type Screw, M2.6 × 6		{ 5430080	Tape Counter . . . . . SC-2000, 2002
8	7690230	G-1200 L.E.D Circuit Board . . . . . SC-3000, 3003	61		Mechanism Ass'y
	7690240	G-1211 L.E.D Circuit Board . . . . . SC-2000, 2002	62	0400530	Pilot Lamp (14V 80mA)
9	7106140	Push Button (A), power switch	63	5440040	Lamp Tube
10	6906032	Spring, power switch	64	4300930	VU Meter
11	7000090	Front Panel Ass'y . . . . . SC-3000	65	5040470	Switch Mask
	7000110	Front Panel Ass'y . . . . . SC-3003	66	5107811	PSA Type Screw, M2.6 × 4
	7000100	Front Panel Ass'y . . . . . SC-2000	67	7690240	G-1201 Switch Circuit Board . . . . . SC-3000, 3003
	7000120	Front Panel Ass'y . . . . . SC-2002		7690250	G-1212 Switch Circuit Board . . . . . SC-2000, 2002
12	5109122	BT Type Screw, M3 × 8	68	5040480	Jack Mask
13	5109915	B Type Screw, M3 × 12	69		Hex. Nut, M12
14	5510120	Rubber Feet	70		P Type Washer, 12φ
15	5050200	Bottom Plate	71	1000340	Semi Variable Resistor
16	5109122	BT Type Screw, M3 × 8	72	1011090	Semi Variable Resistor
17	5440050	Lamp Filter	73	5107853	PSA Type Screw, M3 × 6
18	0420070	Pilot Lamp (8P 100mA)	74	2410970	Voltage Selector
	5440060	Lamp Tube	75	5109916	P Type Screw, M4 × 5
19	7690220	G-1202 Lamp Circuit Board	76	5120161	P Type Washer, 4φ
20	5107853	PSA Type Screw, M3 × 6	77	4002370	Power Transformer
21	0659801	Ceramic Capacitor 0.01μF 150V	78	5109918	PT Type Screw, M3 × 8
	5616220	Tube (For Capacitor)	79	7501480	G-1198 Power Circuit Board
22	1131200	Power Switch	80	5109918	PT Type Screw, M3 × 8
23	5040480	Jack Mask	81	7690190	G-1197 Main Circuit Board . . . . . SC-3000, 3003
24		Hex. Nut, M12		7690270	G-1197 Main Circuit Board . . . . . SC-2000, 2002
25		P Type Washer, 12φ	82	3910490	Cord Clip
26	2430190	Headphone Jack	83	3800261	Power Cord
27	5151002	E Type Washer, 2φ	84	5100344	B Type Screw, M3 × 8
28		Shaft, plunger solenoid	85	5110241	Hex. Nut, M3
29		Shut-off Lever	86	0107474	Carbon Resistor 470kΩ ¼W
30	5160310	Screw, M2.6	87	0107474	Carbon Resistor 470kΩ ¼W
31	5107812	PSA Type Screw, M2.6 × 6	88	0107823	Carbon Resistor 82kΩ ¼W
32	5103323	P Type Screw, M2.6 × 6	89	0107823	Carbon Resistor 82kΩ ¼W
33	5120120	P Type Washer, 2.6φ	90	7710090	Input-Output Terminal Ass'y
34	6030140	Tension Belt	91	2430170	Microphone Jack
35	5105502	SC Type Screw, M2 × 3	92	5100221	B Type Screw, M2.6 × 4
36	7060220	Motor Pulley	93	1190330	Leaf Switch (H-7159), PLAY
37	4320360	Motor	94	5100221	B Type Screw, M2.6 × 4
38	5101042	B Type Screw, M3 × 5	95	1190320	Leaf, switch (H-7158), REWIND . . . . . SC-3000, 3003
39	4340150	Plunger Solenoid			
40	5107811	PSA Type Screw, M2.6 × 4	96		Bracket, leaf switch
41	1190340	Leaf Switch (H-7160), PAUSE			
42		Bracket, plunger solenoid			
43		Retainer, flywheel			
44	5040460	Button Mask			
45	5107853	PSA Type Screw, M3 × 6			
46	5107812	PSA Type Screw, M2.6 × 6			
47		Bracket, mechanism ass'y			
48	6030150	Counter Belt			
49	5107853	PSA Type Screw, M3 × 6			
50	5500570	Rubber Holder, reed switch			
	1190350	Reed Switch			
51		Bracket, reed switch			
52		E Type Washes, 1.0φ			
53	7060210	Counter Idler Ass'y			
54	5107853	PSA Type Screw, M3 × 6			

### 6-3. Disassembly of the Mechanism Ass'y

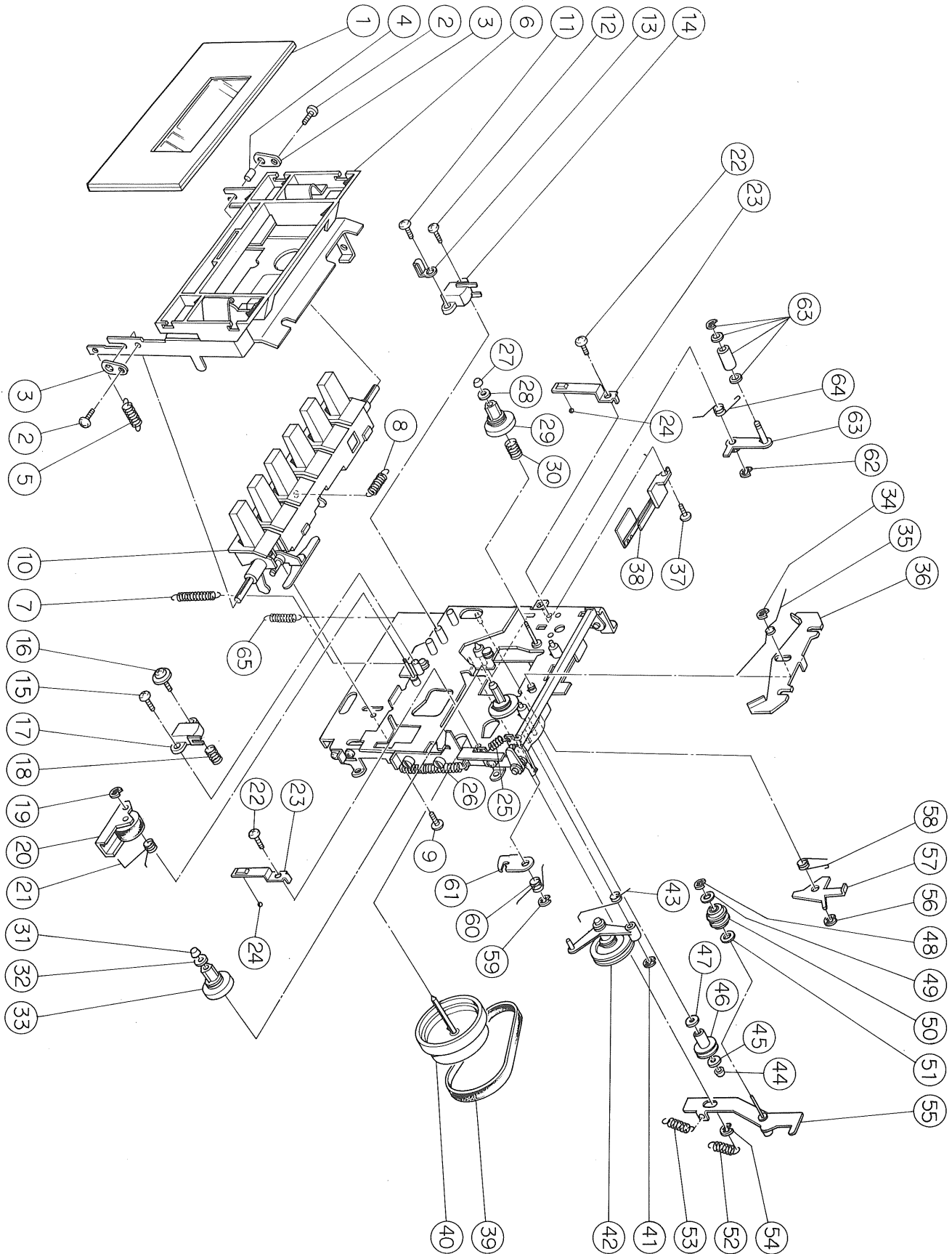

## Parts List

Parts No.	Stock No.	Description
1	7010101	Cassette Lid Ass'y. .SC-2000, SC-3000
	7010130	Cassette Lid Ass'y. .SC-2002
	7010110	Cassette Lid Ass'y. .SC-3003
2	5107811	PSA Type Screw, M2.6 X 4
3		Holder, cassette well
4		Spacer
5	6901250	Spring, cassette UP
6	7010121	Cassette Well Ass'y
7	6901110	Spring, head
8		Spring, stop operation
9	5107812	PSA Type Screw, M2.6 X 6
10	7050080	Control Button Ass'y
11	5107803	PSA Type Screw, M2 X 6
12	5109920	WT Type Screw, M2 X 6
13		Lug Terminal
14	4526010	Erase Head (WY-241Z)
15	5107802	PSA Type Screw, M2 X 5
16	5109920	WT Type Screw, M2 X 5
17	4536010	REC/P.B Head (HN-424822)
18	6901100	Spring, erase head adjustment
19	5151002	E Type Washer, 2φ
20	7060160	Pinch Roller Arm Ass'y
21	6901180	Spring, pinch roller
22	5103022	P Type Screw, M2.6 X 4
23	6901070	Spring, head base stopper
24	6540040	Steel Ball 2.5φ
25	6901290	Spring, timing lever
26	6901270	Spring, hook lever
27	5370090	Cap
28	5180380	P Type Washer, 1.8φ
29	7150070	Reel Hub(B) Ass'y
30	6901340	Spring, back tension
31	5370090	Cap
32	5180380	P Type Washer, 1.8φ
33	7150070	Reel Hub(B) Ass'y
34	5151011	E Type Washer, 2.5φ
35	6901090	Spring, brake lever
36		Brake Lever
37	5107812	PSA Type Screw, M2.6 X 6
38	1190310	Leaf Switch (H-7157), REWIND
39	6030130	Capstan Belt
40	7040200	Flywheel Ass'y
41	5151011	E Type Washer, 2.5φ
42	7060190	Tension Arm Ass'y
43	6901150	Spring, roller arm
44	5370090	Cap
45		P Type Washer, 1φ
46	7060200	Idler Ass'y
47	5180420	P Type Washer, 1.6φ
48	5151011	E Type Washer, 2.5φ
49	5180410	P Type Washer, 2.5φ
50	7060170	Idler(A) Ass'y
51	5180410	P Type Washer, 2.5φ
52	6901140	Spring, REWIND lever
53	6901170	Spring, FR lever
54	5151011	E Type Washer, 2.5φ
55	7160060	FR Lever Ass'y
56	5151011	E Type Washer, 2.5φ
57		REC Lever
58	6901210	Spring, REC lever
59	5151011	E Type Washer, 2.5φ
60	6801160	Spring, pause rock plate

Parts No.	Stock No.	Description
61		PAUSE Rock Plate
62		E Type Washer, 1.5φ
63	7060180	Idler(B) Ass'y
64	6901200	Spring, idler(B) lever
65	6901190	Spring, PAUSE lever

## ◆ Packing List

Parts No.	Stock No.	Description
1	9010090	Inner Packing
2	9110090	Vinyl Cover
3	9020010	Stylofoam Packing
4	9000330	Carton Case (SC-2000)
	9000340	Carton Case (SC-3003)
	9000350	Carton Case (SC-3000)
	9000360	Carton Case (SC-2002)
5	5996080	Curl Stopper

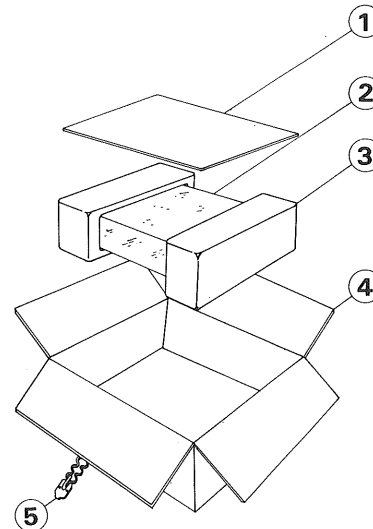

## ◆ Accessory Parts List

Stock No.	Description
9230130	Schematic Diagram (SC-3000)
9230140	Schematic Diagram (SC-3003)
9230150	Schematic Diagram (SC-2000)
9230160	Schematic Diagram (SC-2002)
9209450	Operating Instructions (SC-3000)
9209640	Operating Instructions (SC-3003)
9209650	Operating Instructions (SC-2000)
9209670	Operating Instructions (SC-2002)
9430031	Head Cleaning Pen
3810240	Input-Output Cord

## 7. OPERATION OF MECHANISM

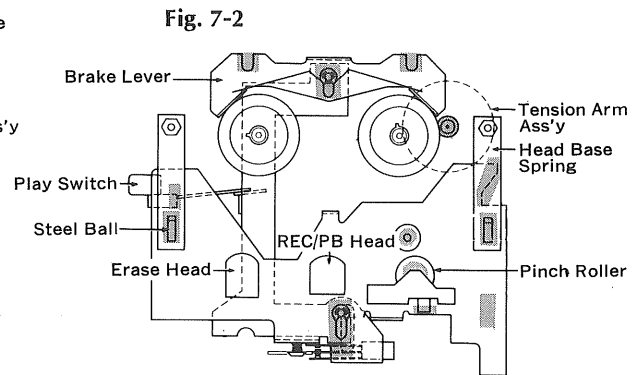
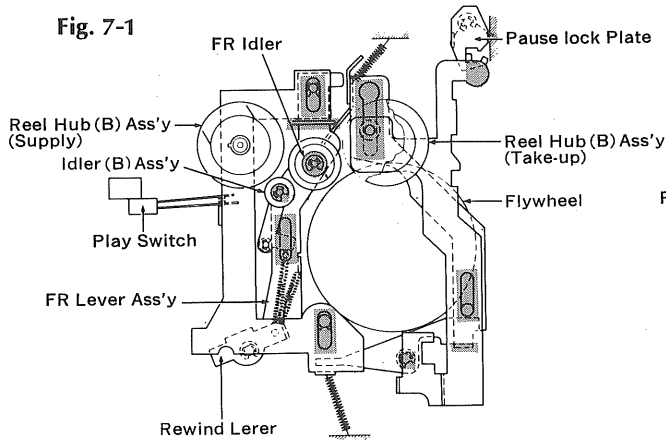

### 7-1. Driving Mechanism (See Fig. 7-3, 7-4)

Motor begins to rotate by pushing the REWIND, PLAY and FF button. The Driving Motor is electronically controlled DC Motor.

Driving Torque is transmitted to Take-up Pulley by Motor Pulley and Capstan Belt through Flywheel. They are always rotating when the cassette tape is running.

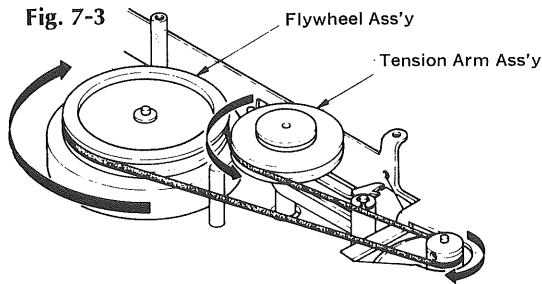

<Driving Mechanism>

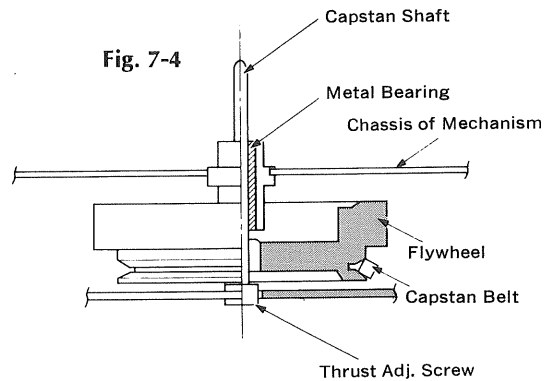

<Detail of Flywheel Ass'y>

### 7-2. Forward Mode (See Fig. 7-5, 7-6 and 7-7)

When the PLAY Button is pushed, the head base moves toward the Reel Hub. It makes the Take-up Pulley Shaft bear against the Reel Hub. At the same time, the Brake is released by Brake Lever and Pinch Roller bears against the Capstan Pulley through tape. In accordance with the above, cassette tape gets constant speed running.

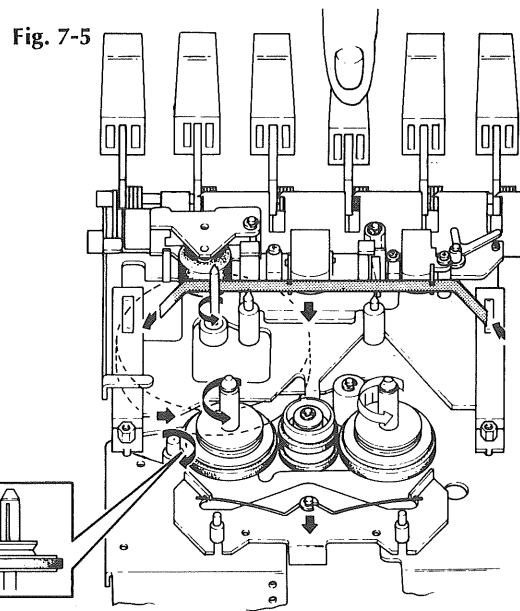

<Forward Operation>



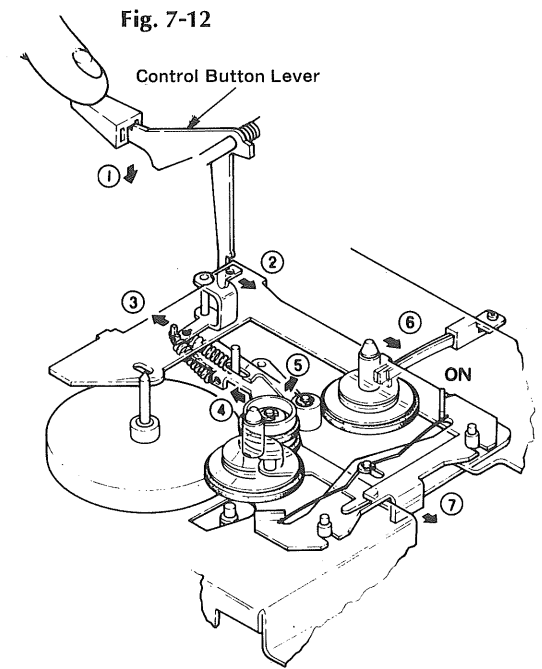
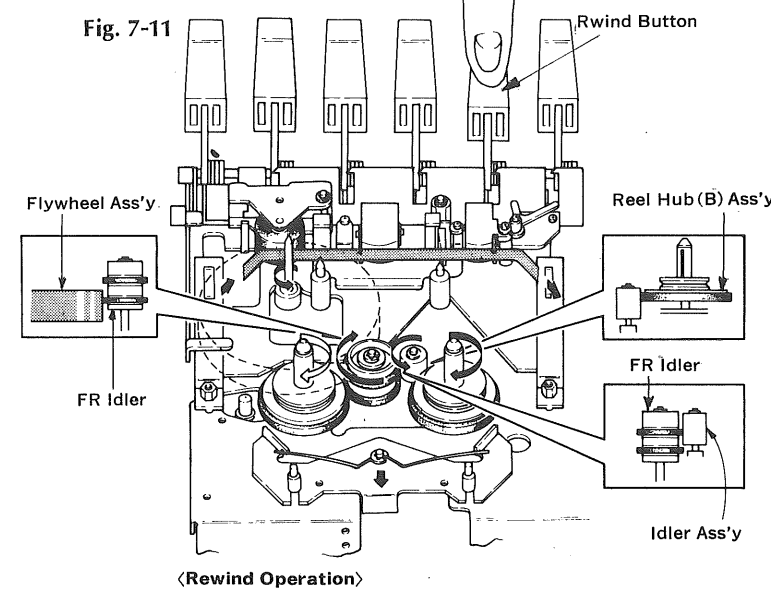
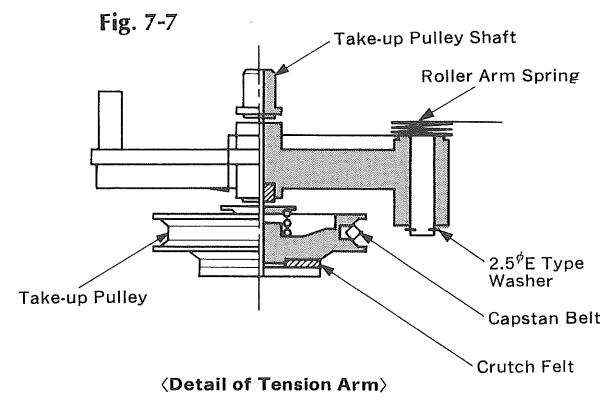
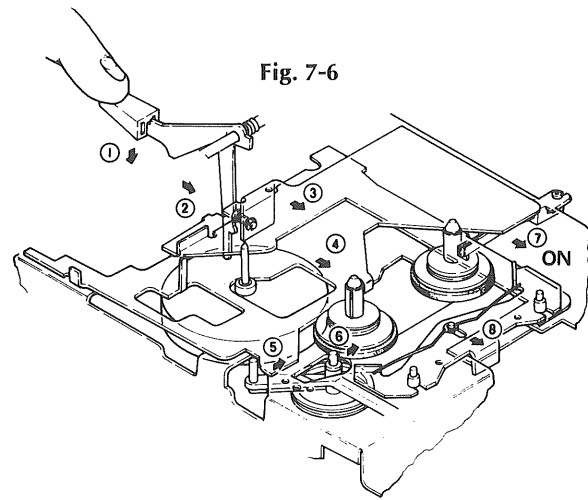

**7-3. Fast Forward and Rewind Operation (See Fig. 7-8, 7-9, 7-10, 7-11 and 7-12)**

When the FF Button is pushed, the FR Idler bears against the Flywheel and Reel hub. When the REWIND button is pushed, the above Mechanism is operated through REWIND Idler between FR Idler and Reel hub. The take-up torque in FF MODE is transmitted from

Flywheel next FR Idler to Reel hub and REWIND torque is transmitted from Flywheel next FR Idler and REWIND Idler to Reel hub. Abnormal torque occurred by tape starting, tape stopping or other causes is absorbed by slipping of felt around FR Idler.

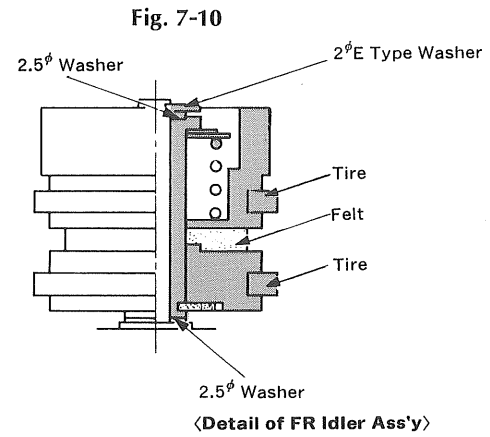
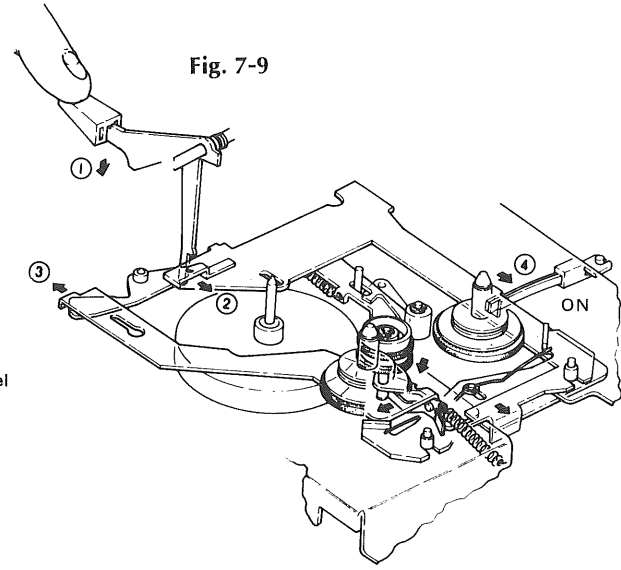
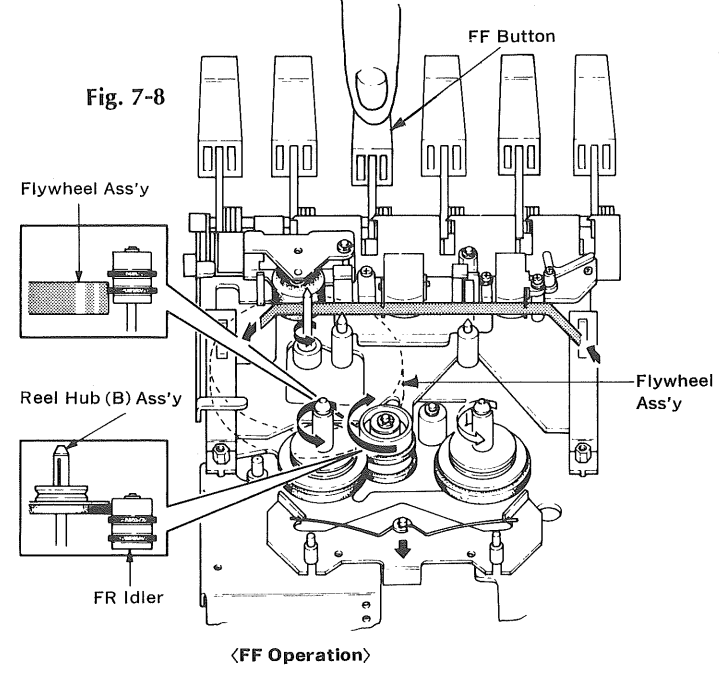

**7-4. Pause Mode (See Fig. 7-13)**

PAUSE Button is only operated in PLAY or REC MODE. When the PAUSE Button is pushed, the Pinch Roller is disengaged from Capstan shaft and Take-up Pulley shaft is disengaged from the Reel hub. It stops tape running.

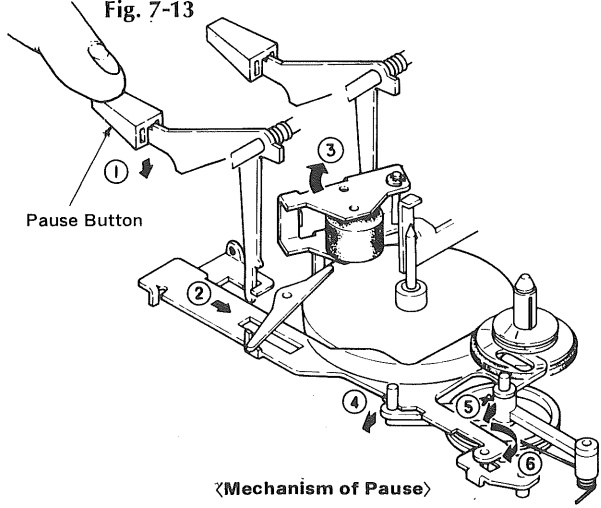

**7-5. REC Mode**

Tape transport mechanism is same as that of PLAY MODE operation. A cassette has "tabs" on the side opposite to that exposing the bare tape. If they are broken off, the cassette will prevent the depression of RECORD Button. When the Record Button and the PLAY Button are pushed, the slide switch on G-1197 main circuit board is changed from PLAY MODE to REC MODE.

# 8. SCHEMATIC DIAGRAM / 8-1. SC-2000, SC-2002 Schematic Diagram

\* La présentation et les spécifications sont susceptibles d'être modifiées sans préavis par suites d'améliorations éventuelles.  
 \* Änderungen, die dem technischen Fortschritt dienen, bleiben vorbehalten.  
 \* Design and specifications subject to change without notice for improvements.

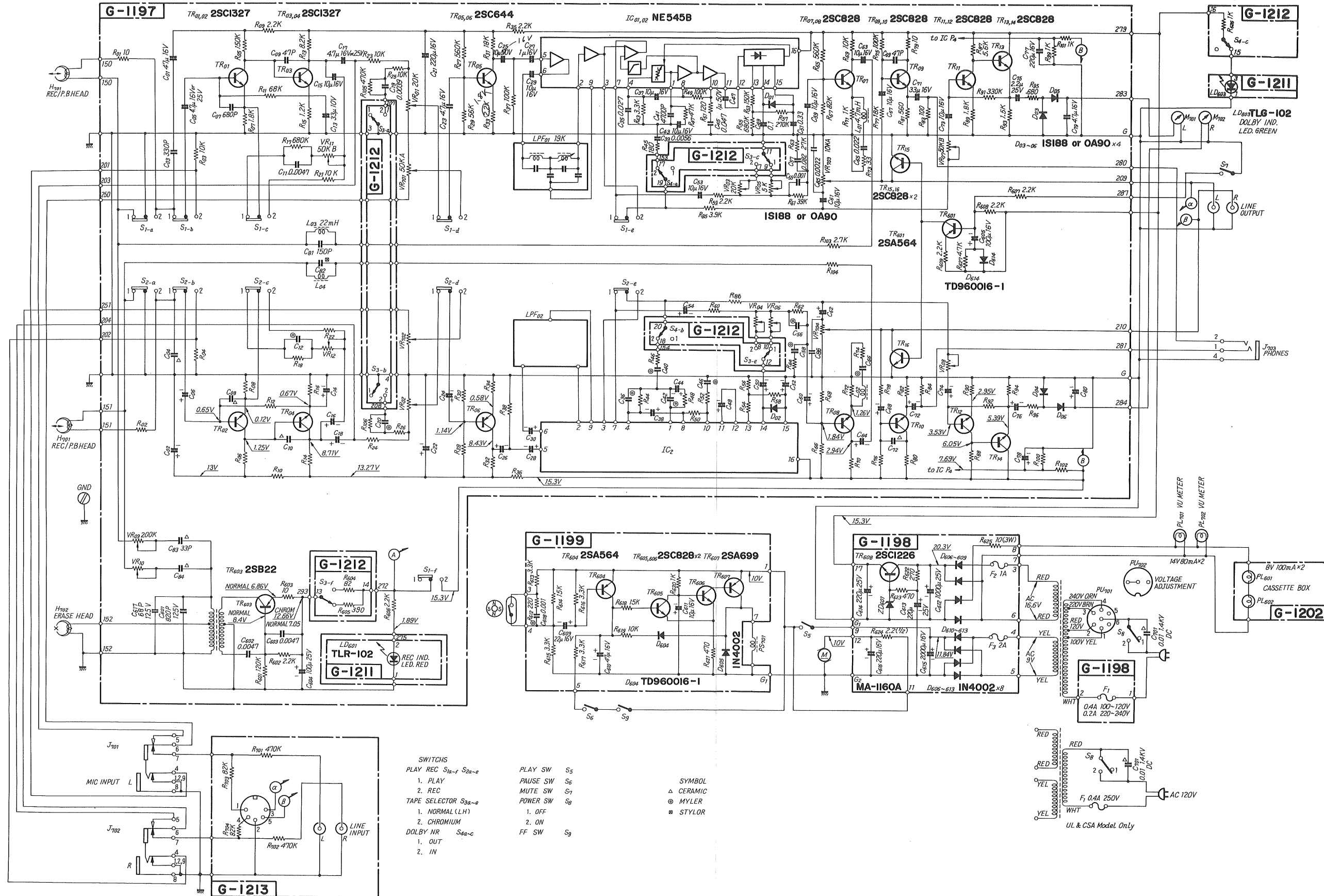

### 8-2. SC-3000, SC-3003 Schematic Diagram

\* La présentation et les spécifications sont susceptibles d'être modifiées sans préavis par suites d'améliorations éventuelles.  
 \* Änderungen, die dem technischen Fortschritt dienen, bleiben vorbehalten.  
 \* Design and specifications subject to change without notice for improvements.

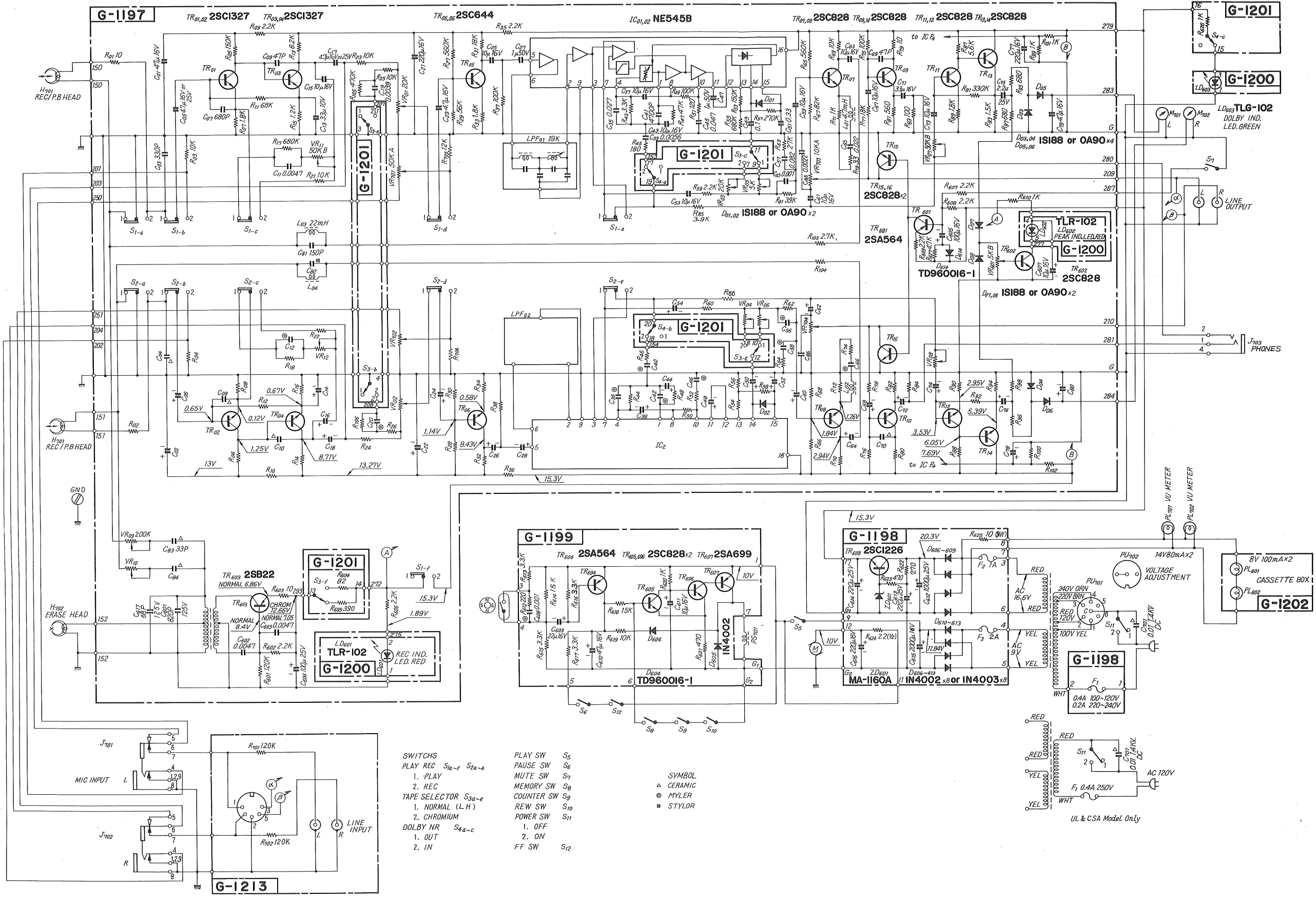

- |                            |                   |               |
|----------------------------|-------------------|---------------|
| <b>SWITCHES</b>            | <b>PLAY SW</b> S5 | <b>SYMBOL</b> |
| PLAY REC S1a~f S2a~e       | PAUSE SW S6       | ▲ CERAMIC     |
| 1. PLAY S1                 | MUTE SW S7        | ● MYLER       |
| 2. REC S2                  | MEMORY SW S8      | ■ STYLOR      |
| <b>TAPE SELECTOR S3a~e</b> | COUNTER SW S9     |               |
| 1. NORMAL (L.H.) S3a       | REW SW S10        |               |
| 2. CHROMIUM S3b            | POWER SW S11      |               |
| <b>DOLBY NR S4a~c</b>      | 1. OFF S11-1      |               |
| 1. OUT S4a                 | 2. ON S11-2       |               |
| 2. IN S4b                  | FF SW S12         |               |

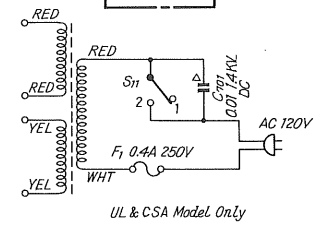

## 9. REPLACEMENT OF MAIN PARTS

### 9-1. Replacement of Mechanism Ass'y (See Fig. 9-1)

1. Remove screw ① and plunger solenoid ②.
2. Remove screw ③, capstan belt ④ and Flywheel holder ⑤.
3. Remove screw ⑥, ⑦, and Mechanism Ass'y will be easily off.

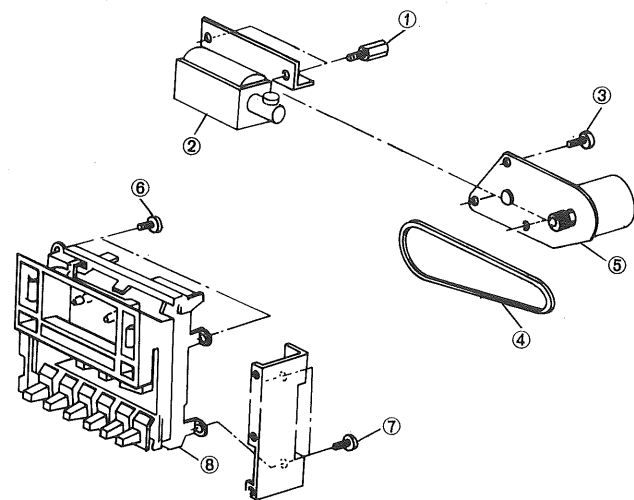

Fig 9-1

### 9-2. Replacement of Cassette Well Ass'y (See Fig. 9-2)

1. Depress EJECT button.
2. Remove screws ① and ② on both sides in Fig. 9-2.
3. Move up the retainer (A), then release it from (B).
4. Pull the cassette well toward the front, and it will be easily off.

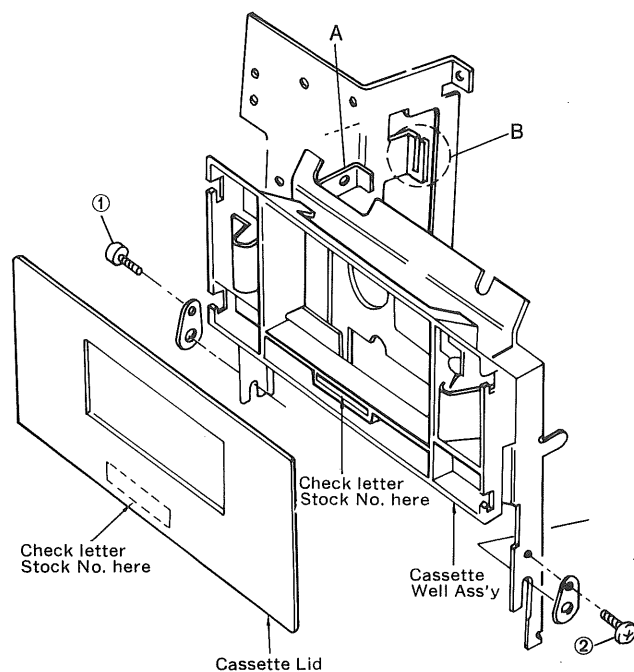

Fig. 9-2 Type A Cassette well & Cassette lid

### 10-3. Replacement of Cassette well and Cassette lid

SC-3000 and SC-3003, both Cassette decks use either type A or type B, cassette well and cassette lid as shown in the list, Please confirm either the parts of type A or B installed in the cassette deck. If necessary, order them together with the model name, stock No. parts name specifically referring to the followings.

Model	Type	Parts name	Stock No.
SC-3000 & SC-3003	A	Cassette well Ass'y	7010121
		Cassette lid	7010101
SC-3000 & SC-3003	B	Cassette well Ass'y	7010120
		Cassette lid	7010100