

SERVICE MANUAL

STEREO CASSETTE TAPE DECK

SANSUI SC-2100/2110 3100/3110



SPECIFICATIONS

* SC-2100/2110	
TRACK	4-Track (2-Channel Stereo)
TAPE SPEED	4.8 cm/sec. (1-7/8 ips)
HEADS	Record/Playback: Hard Permalloy Head Erase: Ferrite Head
MOTOR	Electronically Controlled DC Motor
WOW AND FLUTTER	within 0.08% WRMS
FAST WIND TIME	approximately 75 sec. (C-60)
FREQUENCY RESPONSE (Record/Playback)	
Normal Tape (LH)	25 to 14,000Hz (30 to 13,000Hz ±3dB)
Ferrichrome Tape	25 to 16,000Hz (30 to 14,000Hz ±3dB)
SIGNAL TO NOISE RATIO (Record/Playback)	
Ferrichrome Tape (without Dolby Noise Reduction Effect)	better than 57dB (weighted)
With Dolby Noise Reduction	better than 67dB (above 5kHz)
ERASURE FACTOR	more than 60dB at 1,000Hz
INPUT SENSITIVITY & IMPEDANCE (0 VU, 1,000Hz)	
MIC	0.2mV 200Ω ~ 10kΩ
LINE	70mV 100kΩ
DIN Connector Socket	0.2mV 4.7kΩ
OUTPUT LEVEL (0 VU, 1,000Hz)	
LINE	400mV
DIN Connector Socket	400mV
HEADPHONE IMPEDANCE	8Ω
BIAS FREQUENCY	85kHz
POWER REQUIREMENTS	
Voltage	100, 120, 220, 240V 50/60Hz 120V (Usable 110 ~ 130V) 60Hz (For USA & Canada only)
Consumption	14.5W (rated)
DIMENSIONS	
SC-2100	456mm (18")W, 198mm (7-7/8")H, 322mm (12-3/4")D
SC-2110	430mm (17")W, 171mm (6-3/4")H, 322mm (12-3/4")D
WEIGHT	8.3kg (18.3 lbs.) net 10.2kg (22.5 lbs.) packed
* SC-3100/3110	
TRACK	4-Track (2-Channel Stereo)
TAPE SPEED	4.8 cm/sec. (1-7/8 ips)
HEADS	Record/Playback: Hard Permalloy Head Erase: Ferrite Head
MOTOR	FG Servo DC motor
WOW AND FLUTTER	within 0.06% WRMS
FAST WIND TIME	within 75 sec. (C-60)
FREQUENCY RESPONSE (Record/Playback)	
Normal Tape (LH)	25 to 14,000Hz (30 to 13,000Hz ±3dB)
Ferrichrome Tape	25 to 16,000Hz (30 to 14,000Hz ±3dB)
SIGNAL TO NOISE RATIO (Record/Playback)	
Ferrichrome Tape (without Dolby Noise Reduction Effect)	better than 57dB (weighted)
With Dolby Noise Reduction	better than 67dB (above 5kHz)
ERASURE FACTOR	more than 60dB at 1,000Hz
INPUT SENSITIVITY & IMPEDANCE (0 VU, 1,000Hz)	
MIC	0.2mV 200Ω ~ 10kΩ
LINE	70mV 100kΩ
DIN Connector Socket	0.2mV 4.7kΩ
OUTPUT LEVEL (0 VU, 1,000Hz)	
LINE	400mV
DIN Connector Socket	400mV
HEADPHONE IMPEDANCE	8Ω
BIAS FREQUENCY	85kHz
POWER REQUIREMENTS	
Voltage	100, 120, 220, 240V 50/60Hz 120V (Usable 110 ~ 130V) 60Hz (For USA & Canada only)
Consumption	14.5W (rated)
DIMENSIONS	
SC-3100	456mm (18")W, 198mm (7-7/8")H, 322mm (12-3/4")D
SC-3110	430mm (17")W, 171mm (6-3/4")H, 322mm (12-3/4")D
WEIGHT	8.3kg (18.3 lbs.) net 10.2kg (22.5 lbs.) packed

Sansui

SANSUI ELECTRIC CO., LTD.

* Designed and specifications subject to change without notice for improvements.

†Dolby is a trademark of Dolby Laboratories, Inc.

1. BLOCK DIAGRAM

1) SC-2100/2110

◇Recording Operation Block Diagram

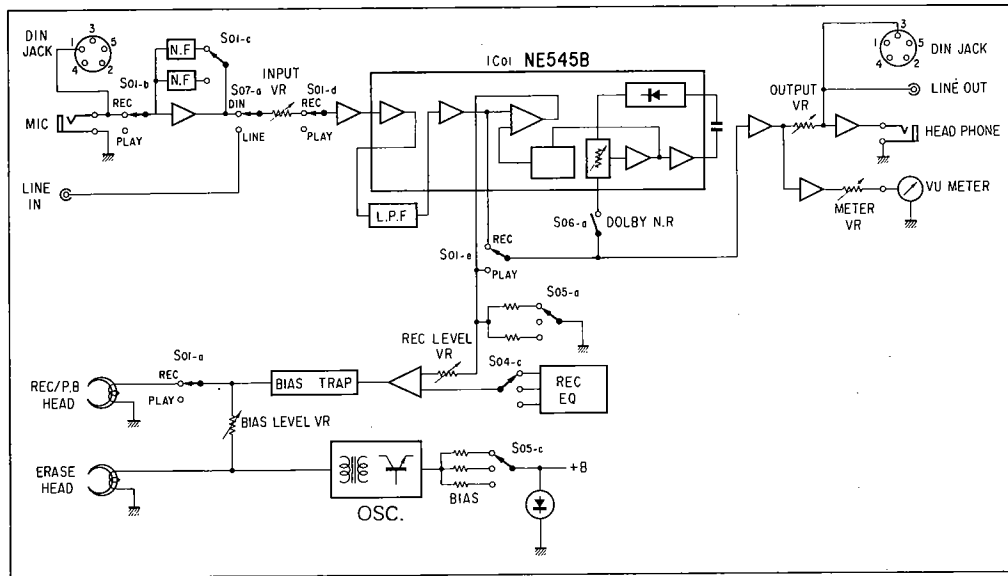

◇Playback Operation Block Diagram

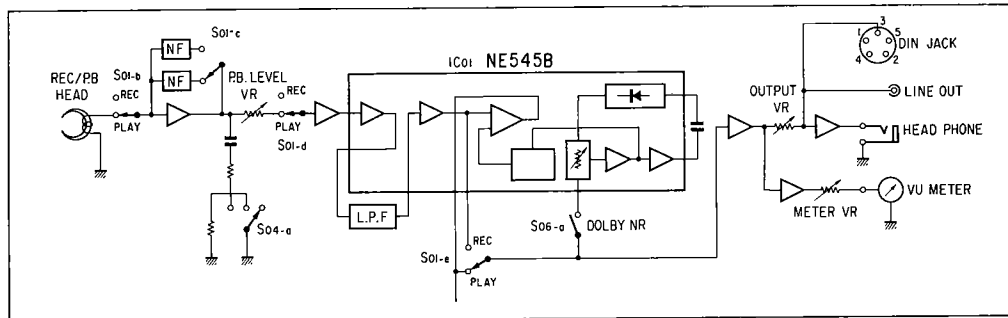

2) SC-3100/3110

◇Recording Operation Block Diagram

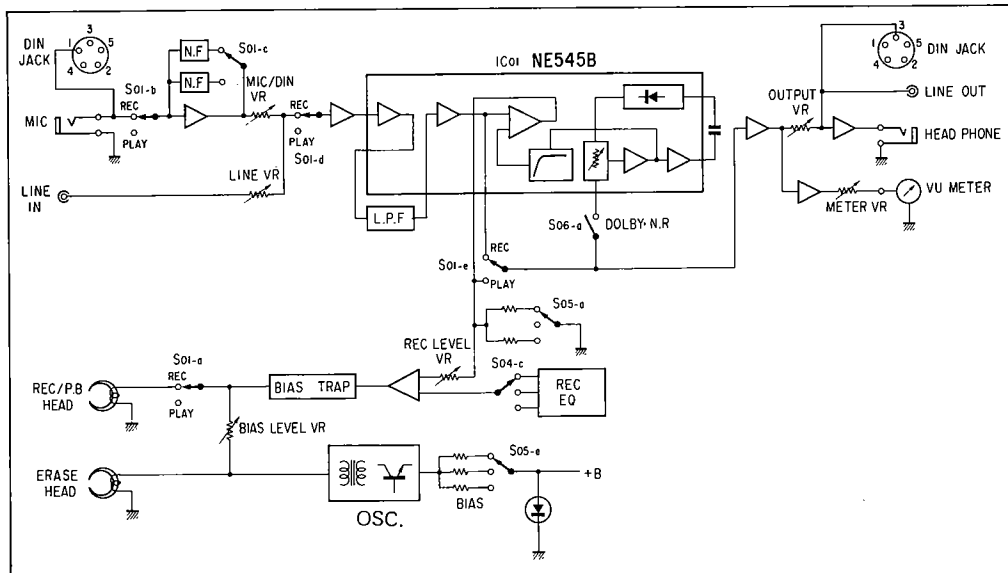

<SC-3100/3110>

◊Playback Operation Block Diagram

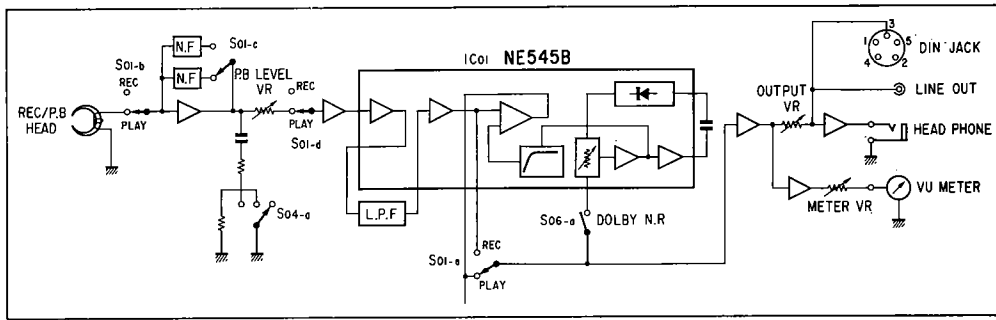

2. OPERATION

1) Timer Start (Recording)

- 1) In recording mode, make Pause switch ON.
- 2) When Power switch is turned ON, TR613 is OFF and TR614 is ON while charging current flows into C633.
- 3) After C633 has been charged, TR614 becomes OFF that the charging current flows into C634. This charging current turns ON the TR615 that base voltage of TR609 is drawn to ground voltage.
- 4) TR609 turns ON that SL701 functions to release the Pause lock.
- 5) As a result, the unit starts recording after a little time lag defined by R639 and C633 when power is switched ON.

2) Tape Lead-in (See Fig. 2-1)

Since TR610 and TR611 operate as a monostable multivibrator, a negative pulse appears at base of TR611 by turning on the switch S08-a that TR612 turns ON while the pulse appears. S08-a also turns ON TR610 that the LED starts lighting. When TR612 becomes ON, TR607 is OFF, TR608 is ON, TR609 is ON that PLUNGER functions. To function the PLUNGER has Time Constant defined by C628, R629 and this Time Constant determines the time of TAPE LEAD-IN.

Fig. 2-1

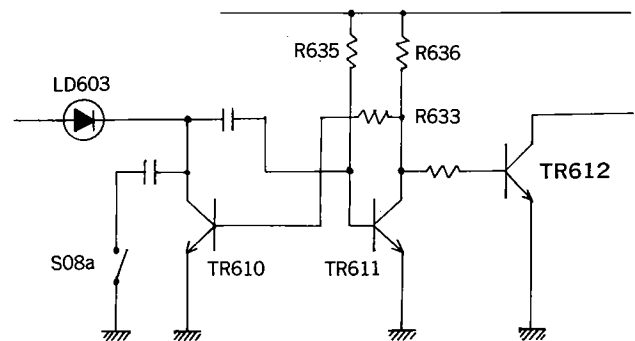

3) Muting (See Fig. 2-2)

- 1) Excepting PLAY Mode, the switch S10-b is always ON and base voltage of TR601 is about +B/2 that TR601 is ON and MUTING circuit functions.
- 2) When PLAY button is depressed, the switch S10-b turns OFF so that base voltage of TR601 starts gradually increasing and turns OFF TR601.
- 3) While the switch S10-b is ON, C601 has been charged therefore to increase the base voltage of TR601, it has time delay defined by C601 and R601.
- 4) When TR601 is turned OFF, TR13 and TR14 become OFF that MUTING is released.
- 5) Resultly, output signal appears with time delay to avoid in-stable function after PLAY button is pushed.

Fig. 2-2

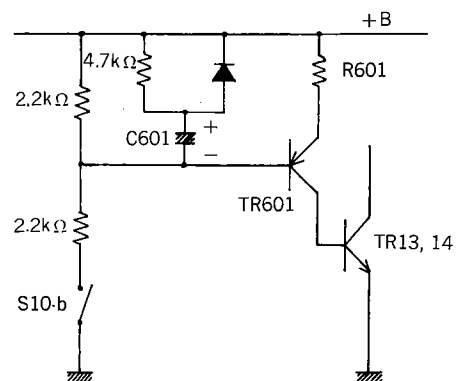

3. OPERATION OF MECHANISM

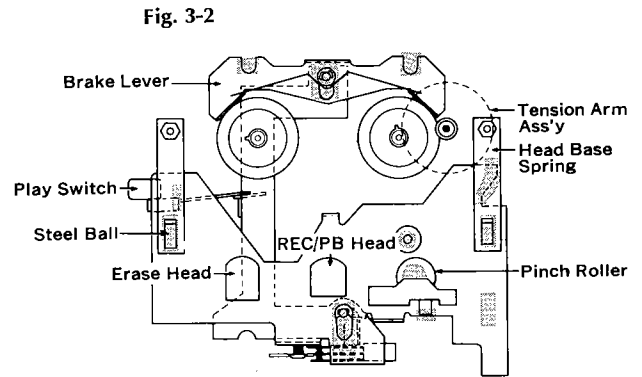
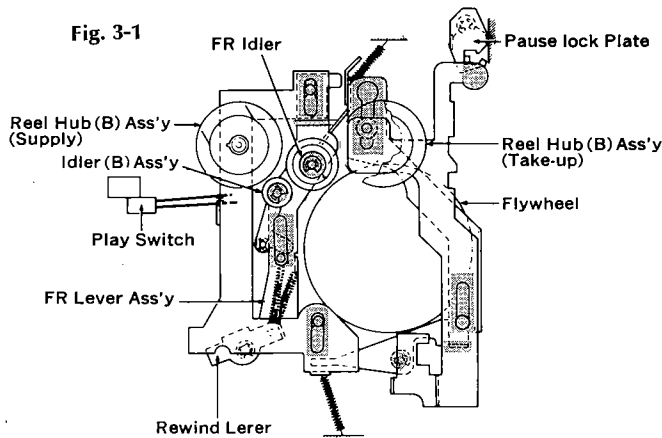

1) Driving Mechanism (See Fig. 3-3)

Motor begins to rotate by pushing the REWIND, PLAY and FF button. The Driving Motor is electronically controlled DC Motor. Driving Torque is transmitted to Take-up Pulley by Motor Pulley and Capstan Belt through Flywheel. They are always rotating when the cassette tape is running.

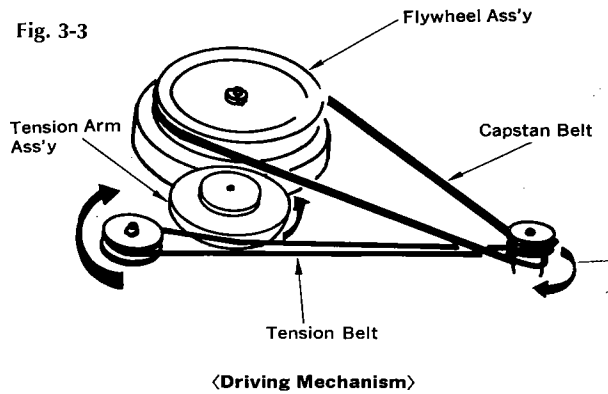

2) Forward Mode (See Fig. 3-4, 3-5, & 3-6)

When the PLAY Button is pushed, the head base moves toward the Reel Hub. It makes the Take-up Pulley Shaft bear against the Reel Hub. At the same time, the Brake is released by Brake Lever and Pinch Roller bears against the Capstan Pulley through tape. In accordance with the above, cassette tape gets constant speed running.

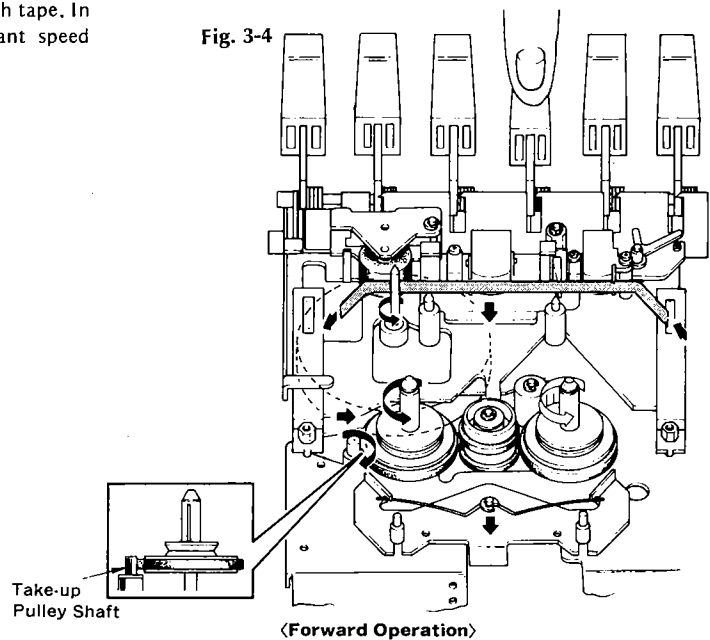

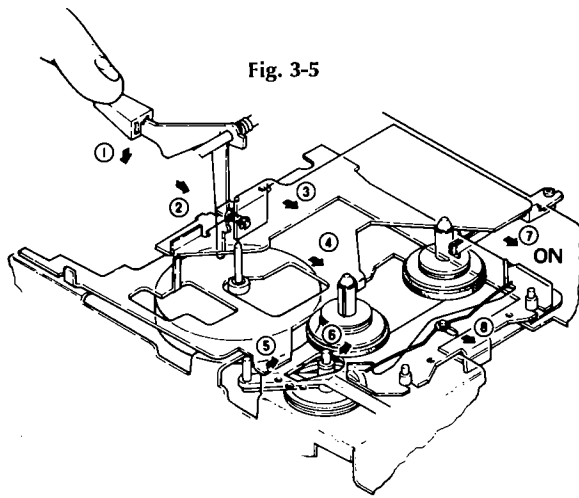

Fig. 3-5

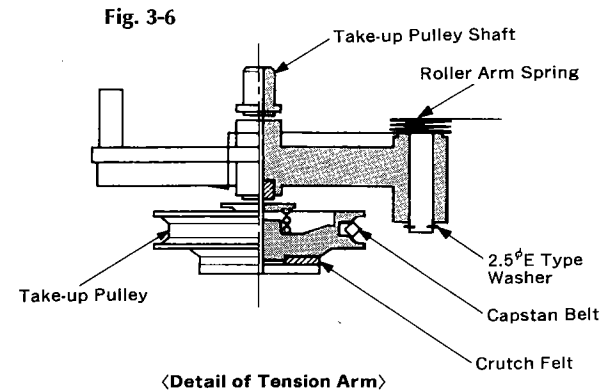

Fig. 3-6

<Detail of Tension Arm>

3) Fast Forward & Rewind Operation (See Fig. 3-7, 3-8, 3-9, 3-10 & 3-11)

When the FF Button is pushed, the FR Idler bears against the Flywheel and Reel hub. When the REWIND button is pushed, the above Mechanism is operated through REWIND Idler between FR Idler and Reel hub. The take-up torque in FF MODE is transmitted from Flywheel next FR Idler to Reel hub and REWIND torque is transmitted from Flywheel next FR Idler and REWIND Idler to Reel hub. Abnormal torque occurred by tape starting, tape stopping or other causes is absorbed by slipping of felt around FR Idler.

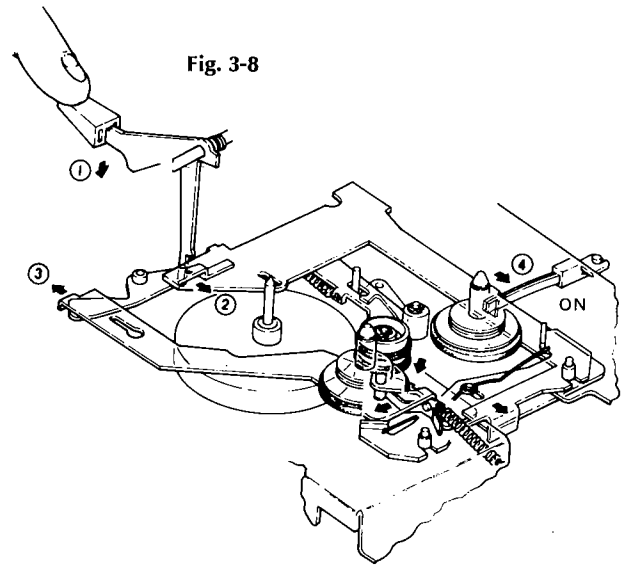

Fig. 3-8

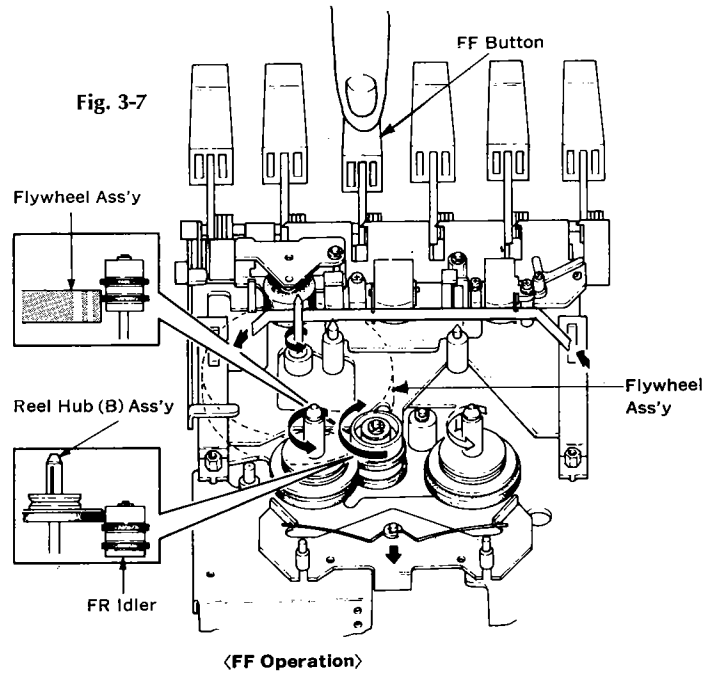

Fig. 3-7

<FF Operation>

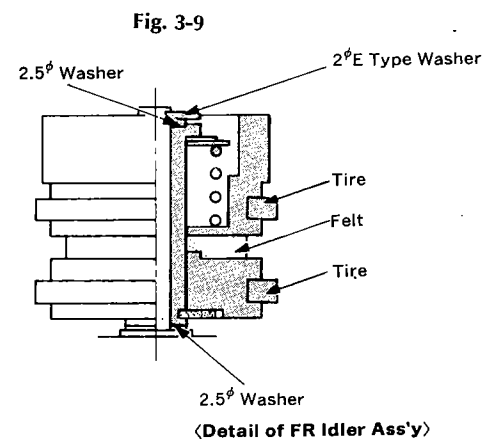

Fig. 3-9

<Detail of FR Idler Ass'y>

Fig. 3-10

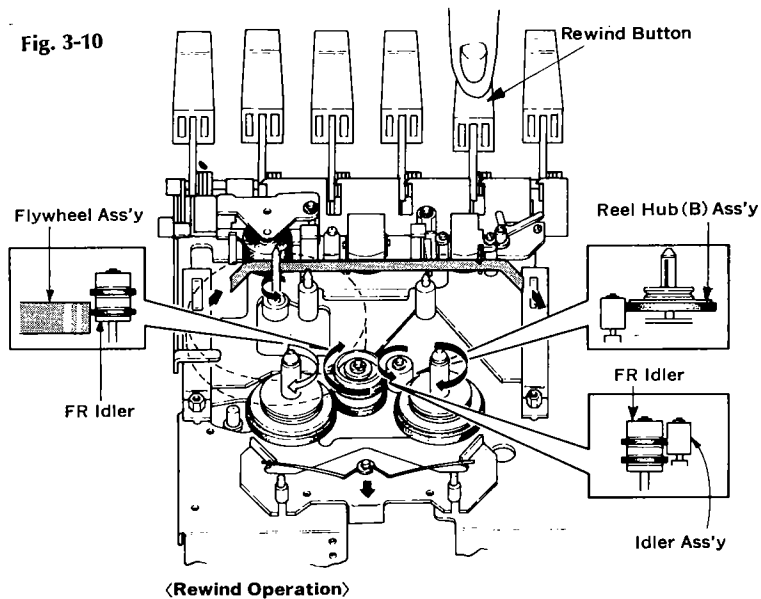
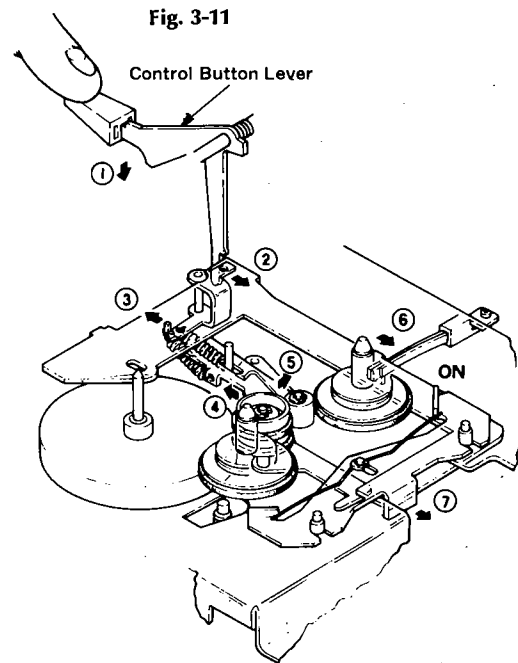

Fig. 3-11



4) Pause Mode (See Fig. 3-12)

PAUSE Button is only operated in PLAY or REC MODE. When the PAUSE Button is pushed, the Pinch Roller is disengaged from Capstan shaft and Take-up Pulley shaft is disengaged from the Reel hub. It stops tape running.

Fig. 3-12

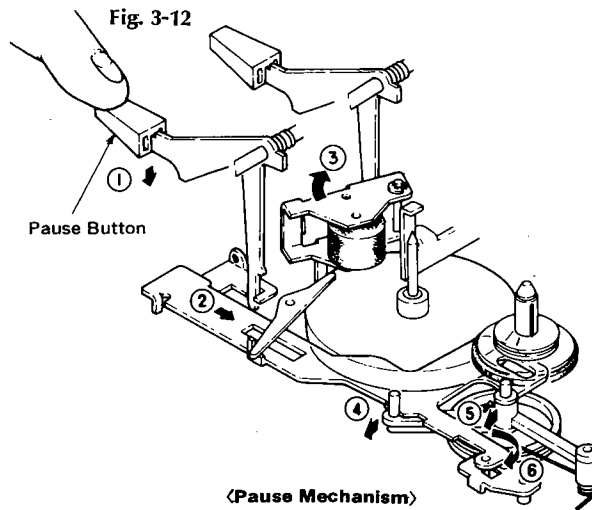

5) REC Mode

Tape transport mechanism is same as that of PLAY MODE operation. A cassette has "tabs" on the side opposite to that exposing the bare tape. If they are broken off, the cassette will prevent the depression of RECORD Button. When the Record Button and the PLAY Button are pushed, the slide switch on G-1217 main circuit board is changed from PLAY MODE to REC MODE.

3. ADJUSTMENTS

1) Tape Speed Adjustment

- Note: (1) Use Sansui Test Tape, SCT-S3K (3 kHz signals are recorded on the tape).
(2) Connections are shown below.

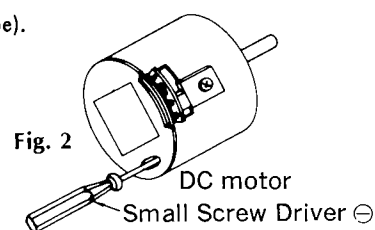
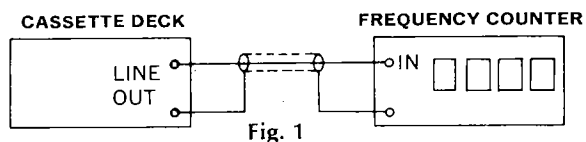

SUBJECT	INPUT SIGNAL	CHECK POINT	SETTING	ADJUST FOR	ADJUST	REMARKS
TAPE SPEED ADJ.	Test Tape SCT-S3K	LINE OUT	Depress the PLAY button and playback the Test Tape, SCT-S3K	3000 Hz $\pm 1.5\%$	If not, turn semi-variable resistor as Fig. 2 until 3000 Hz $\pm 1.5\%$ is obtained.	Use small screw driver.

2) Playback Adjustment

- Note: (1) Before this adjustment, clean REC/P.B head surface.
(2) Demagnetize the head by demagnetizer, if necessary.
(3) For this adjustment, use Sansui Test Tape, SCT- F10KN, SCT-L400N and SCT-F1K.
(4) Set the Dolby switch to be OFF.
(5) Connections are shown below.

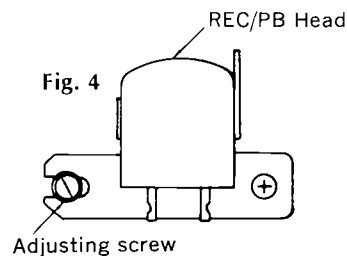
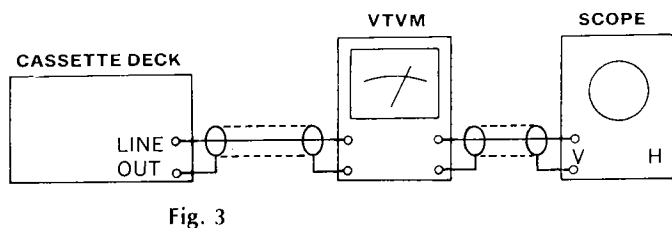

SUBJECT	INPUT SIGNAL	CHECK POINT	SETTING	ADJUST FOR	REMARKS
REC/PB Head Adj.	SCT-F10KN	LINE OUT	Depress the PLAY button and playback the test Tape, SCT-F10KN	Adjust the azimuth adjusting screw in Fig. 4 and tape guide for the maximum reading on the VTVM on both channels.	After this adjustment, lock the screw with paint.
Playback Level Adj.	SCT-L400N	LINE OUT	Set EQ SELECTOR to NORMAL (LH) position	Adjust VR1 (20 k Ω) for L-CH and VR2 (20 k Ω) for R-CH for the reading of 560 mV ± 2 dB on VTVM (See Fig. 5).	Set same level (560 mV) ± 2 dB on both channels.
VU meter Level Adj.			Depress the PLAY button and playback the Test Tape, SCT-L400N	Adjust VR3 (10 k Ω) for L-CH and VR4 (10 k Ω) for R-CH for the reading of +3VU ± 1 VU on VU meter (See Fig. 5).	
High frequency Equalization Check	SCT-F1K and SCT-F10KN	LINE OUT	Set EQ SELECTOR to NORMAL (LH) position. Depress the PLAY button and playback the Test Tape, SCT-F1K and SCT-F10KN	Confirm that the difference of output levels from SCT-F1K and SCT-F10KN is within ± 3 dB.	In playback of SCT-10KN, set the EQ SELECTOR to HIGH (CrO ₂) position, then confirm the indication on VTVM dropping down approximately 4 dB \sim 5 dB.

3) Recording Adjustment

(1) Connection.

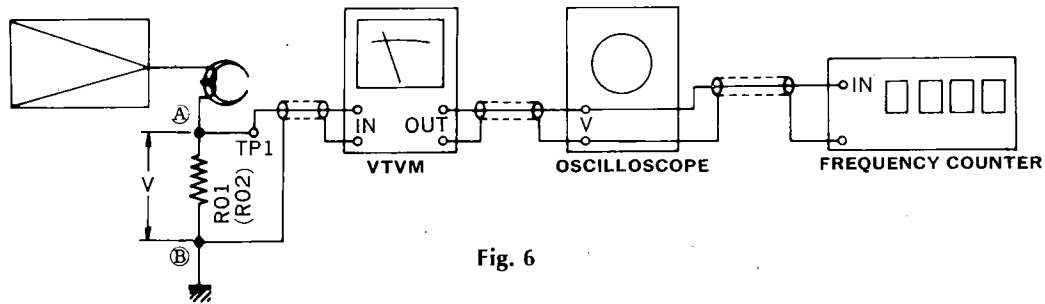

Fig. 6

SUBJECT	INPUT SIGNAL	CHECK POINT	SETTING	ADJUST	REMARKS
Recording bias Adj.		Voltage value between A and B of R01 & R02 (See Fig. 6)	Depress REC and PLAY buttons. Set BIAS SELECTOR to HIGH (CrO ₂) position. Set BIAS SELECTOR to NORMAL (LH) position. Set BIAS SELECTOR to Fe-Cr position.	Adjust VR7 (100 kΩ) for L-CH and VR8 (100 kΩ) for R-CH for the reading of 7.0mV (700 μA) between A and B in Fig. 6 on both channel. Confirm the indication on VTVM shows 4.2mV (420 μA). Confirm the indication on VTVM shows 5.3mV (530 μA).	
Bias Frequency		Same as above	Set BIAS SELECTOR to NORMAL position.	Confirm that frequency counter shows 85 kHz ±5 kHz.	

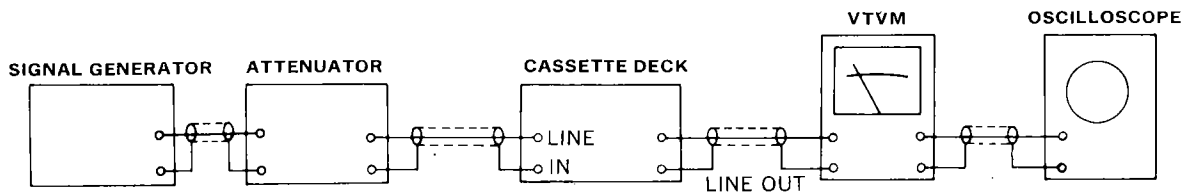

Fig. 7

SUBJECT	INPUT SIGNAL	CHECK POINT	SETTING	ADJUST FOR	REMARKS
REC Level Adj. HIGH (CrO ₂)	Use recording HIGH (CrO ₂) tape SCT-SA Feed 1 kHz, 70 mV (0 dB) from S.G. into LINE IN.	LINE OUT	Set BIAS & EQ SELECTOR to HIGH (CrO ₂) position 1. Depress PAUSE, PLAY and REC button. 2. Adjust the MIC/LINE volume for obtaining 0 dB on the VU meters. 3. Push off the PAUSE button, then record the 1 kHz signal. 4. Play back the 1 kHz signal. 5. Confirm that the output levels on both channels are 400 mV ±2 dB on VTVM	1. If not, turn VR5 (10 kΩ) for L-CH and VR6 (10 kΩ) for R-CH until output Level. 400 mV ±2 dB on both channel are obtained. 2. Repeat this REC Level adj. until the indication on VTVM will be 400 mV ±2 dB. (See Fig. 5)	
Frequency Response Adj. HIGH (CrO ₂)	Feed 1 kHz, 7 mV (-20dB) and 10 kHz; 7 mV (-20dB) from S.G. into LINE IN.	LINE OUT	Set BIAS & EQ SELECTOR to HIGH (CrO ₂) position. 1. Record the 1 kHz and 10 kHz signals from S.G. 2. Play back the 1 kHz and 10 kHz signals, then confirm that the difference of output levels between 1 kHz and 10 kHz are within 0 dB against that of 1 kHz.	1. If not, adjust VR7 (100 kΩ) for L-CH and VR8 (100 kΩ) for R-CH slightly until difference of output levels between 1 kHz and 10 kHz recorded are within 0 dB against that of 1 kHz (See Fig. 5).	As VR7 and VR8 are previously adjusted in step of Bias Adjustment, turn them slightly, if necessary. (See Fig. 5)

* Adjusting Points

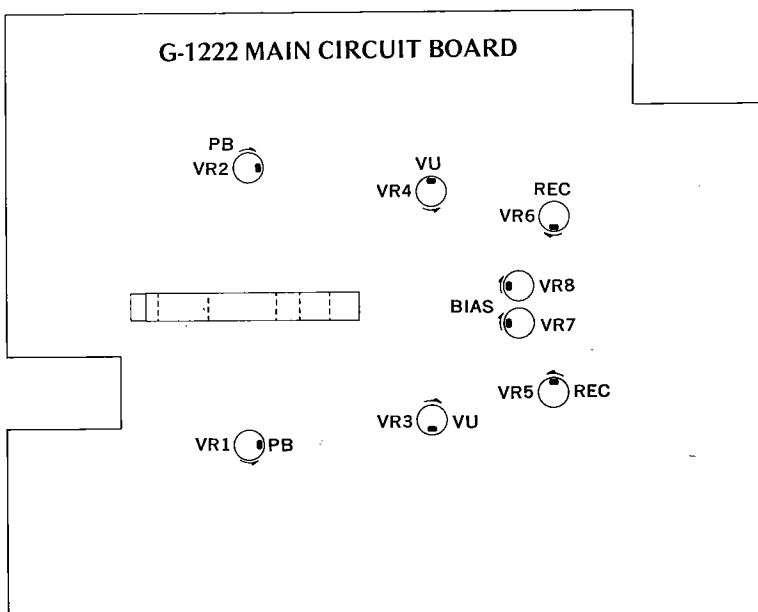

Fig. 5

By turning each adjustment VR accordingly to arrow, the levels of REC, PLAY METER, and BIAS CURRENT are increased.

* List of Sansui Test Tapes

Name of test tape	Recorded Frequency	Description
SCT-S3K	3 kHz	Speed Check, Wow & Flutter Check
SCT-L400N	400 Hz	Playback level and VU meter level adjustment
SCT-F1K	1 kHz	High frequency equalization check
SCT-F10KN	10 kHz	REC/PB head adjustment
SCT-SA [HIGH (CrO ₂)]		Recording bias adjustment
SCT-LH [NORMAL (LH)]		REC/PB level adjustment
SCT-CS (Fe-Cr)		Frequency response check
SCT-F40	40 Hz	Playback frequency response check

※TAPE SELECTOR position

TAPE BANDE TONBAND	MODE	REC	PLAY
	TAPE SELECTOR	BIAS, EQUALIZER	EQUALIZER
AGFA	Hifi-Low-Noise SUPER	normal (LH)	normal (LH)
BASF	LN		
	LH		
	LH super		
FUJI FILM	FL		
	FX		
	FX Duo		
MAXELL	LN		
	UD-XLI		
SCOTCH	LD		
	LH		
SONY	LOW-NOISE HF		
TDK	D		
	SD		
	ED		

TAPE BANDE TONBAND	MODE	REC	PLAY
	TAPE SELECTOR	BIAS, EQUALIZER	EQUALIZER
AGFA	STEREOCHROM	high (CrO ₂)	high (CrO ₂)
BASF	chromdioxid		
MAXELL	UD-XLI		
SONY	CR		
TDK	SA		
BASF	ferrochrom	Fe-Cr	Fe-Cr
SCOTCH	CLASSIC		
SONY	DUAD	normal (LH)	high (CrO ₂)
SCOTCH	Master		
TDK	AD		
FUJI FILM	FX Jr		
MAXELL	UD	normal (LH)	high (CrO ₂)

4. PARTS LOCATION & PARTS LIST

Since some of capacitors and resistors are omitted from parts lists in this Service Manual, refer to the common parts list for capacitors & resistors which was appended previously to each Sansui Manual.

1) G-1222 Main Circuit Board (Stock No. 7620100) (SC-3100/3110) Conductor Side (Stock No. 7620120) (SC-2100/2110)

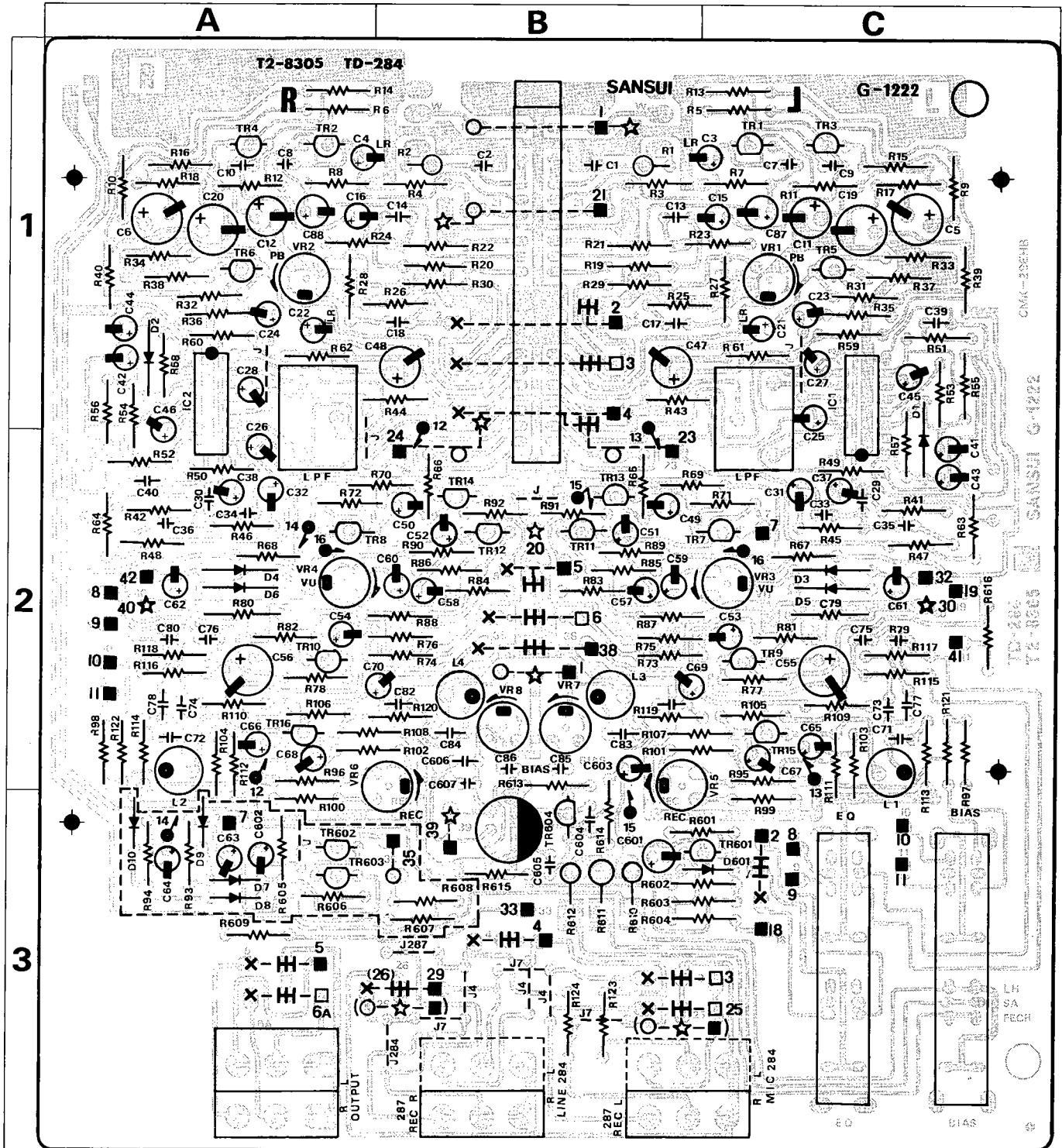

Abbreviations

C.R. : Carbon Resistor	N.I.R. : Non-Inflammable Resistor	C.C. : Ceramic Capacitor
S.R. : Solid Resistor		Mi.C. : Mica Capacitor
Ce.R. : Cement Resistor	M.C. : Mylar Capacitor	O.C. : Oil Capacitor
M.R. : Metallized Film Resistor	E.C. : Electrolytic Capacitor	P.C. : Polystyrene Capacitor
F.R. : Fusing Resistor	BP.E.C. : Bi-Polar Electrolytic Capacitor	T.C. : Tantalum Capacitor

Parts List <G-1222>

Parts No.	Stock No.	Description	Position
TR01 ~ 06	0360340	2SC1327 S, T	1A,C
TR07 ~ 16	0305156	2SC536 G	2B
	0306500	2SC828 R	
TR601	0300272	2SA659 E	3C
	0300810	2SA564	
TR602, 603	0305156	2SC536 G	3A
	0306500	2SC828 R	
TR604	0305952, 3	2SC945 P, K	3B
IC 01, 02	0360340	NE545 B dolby I.C	1C, 1A
D 01 ~ 06	0311480	1S188AM	3A
D 01 ~ 06	0311490	0A90	
D 08, 09	0311160	1S2473	
	0311580	WG-713	
D 601	0311160	1S2473	3C
	0311580	WG-713	
C 01, 02	0620331	330pF 50V P.C	1B
C 03, 04	0519008	47 μF 25V	1C, 1A
C 21, 22	0519010	10 μF 10V	1C, 1A
C 41, 42	0519113	0.1 μF 50V	2C, 1A
C 43, 44	0519112	0.33 μF 50V	2C, 1A
C 63, 64	0515478	0.47 μF 50V	3A
C 65, 66	0519114	0.15 μF 50V	2C, 2A
C 83, 84	0649003	150pF 50V	
C 87, 88	0510330	33 μF 6.3V M.C.	

Parts No.	Stock No.	Description	Position
C 601	0512220	22 F 50V E.C	3B
C 604	0600336	0.0033 F 50V M.C	3B
R 69, 70	0107225	2.2M ¼W	2B
R 79, 80	0103561	560 ¼W	2C, 2A
R 117, 118	0107122	1.2k ¼W	2C, 2A
R 610	0109006	470 ¼W	3B
R 611	0109005	56 ¼W	3B
R 612	0109007	560 ¼W	3B
L 01, 02	4290700	Inductor 4.7mH, Peaking	2C, 2A
L 03, 04	4290320	Inductor 22mH, Bias Trap	2B
	4290260	Inductor 22mH, Bias Trap	
	4220680	OSC, Coil	
	0910351	Low Pass Filter	
VR01, 02	1035150	22k (B) Playback VR	1C, 1B
VR03, 04	1035130	10k (B) Meter VR	2C, 2A
VR05, 06	1035130	10k (B) Recording VR	2B
VR07, 08	1035190	100k (B) Bias VR	2B
VR09, 10	1000350	Volume 10k (A), Input	
		(SC-2100/2110)	
VR11, 12	1011140	Volume 10k (A) x 2, Output	
VR13, 14	1020290	Volume 20k (A) x 2, Line, Mic (SC-3100 only)	
S 01, 02	1131500	PB-REC Switch	
S 03	1190540	REC Leaf Switch	
S 04, 06	1171240	Lever Switch, Equalizer, Bias	

5) G-1223 Power Supply Circuit Board

(Stock No. 7502560 XX, UL, CSA) (SC-3100/3110)
 7502564 BS, EU
 (Stock No. 7502580 XX, UL, CSA) (SC-2100/2110)
 7502584 BS, EU

Conductor Side

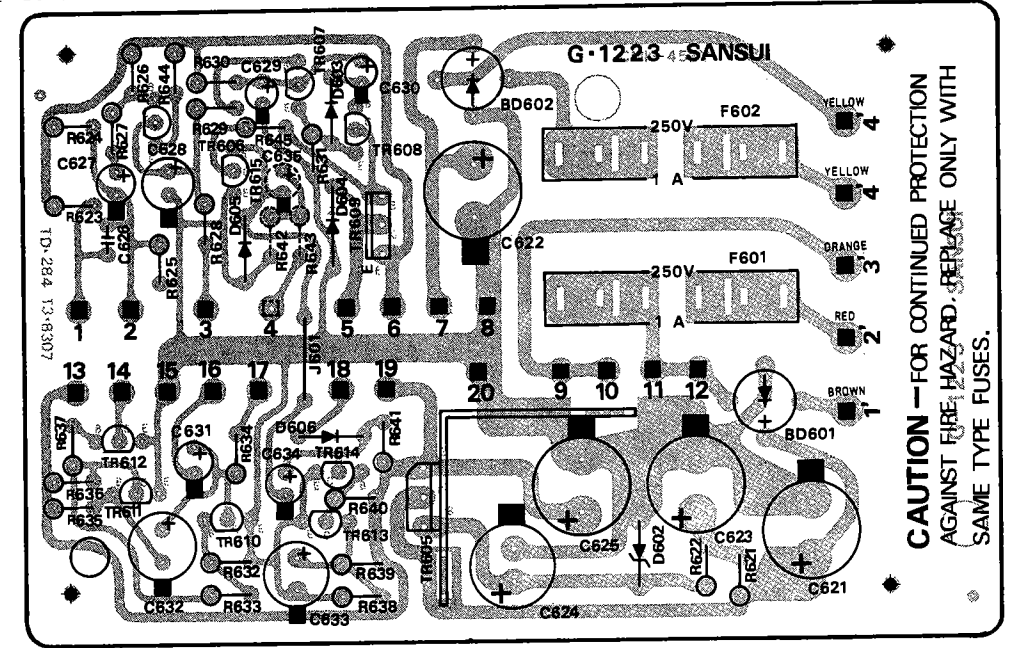

Parts List

Parts No.	Stock No.	Description
TR605	0306440, 1	2SC1226 (Q, R)
TR606	0300272	2SA659 (E)
TR607	0306560	2SC1571 (H)
	0306420	2SC1327 (T, U)
TR608	0305156	2SC536 (G)
TR609	0300940, 1, 2	2SA886 (P, Q, R)
TR610~615	0305156	2SC536 (G)
D603	0311580	WG713
	0311160	1S2473
D604	0311510	1N4002

Parts No.	Stock No.	Description
D605, 606	0311158	WG713
	0311160	1S2473
D62	0316650	WZ-177 Zener Diode
BD601, 602	0311590	WQ2 Diode
C628	0601106	0.001 μF 50V M.C
C627	0512222	22 μF 16V
C628	0519006	47 μF 16V
C630	0515229	2.2 μF 25V
C634	0519113	0.33 μF 50V
R621, 622	0109006	470Ω ¼W N.I.R.

2) G-1221 Muting Circuit Board

(Stock No. 7595640)

Conductor Side

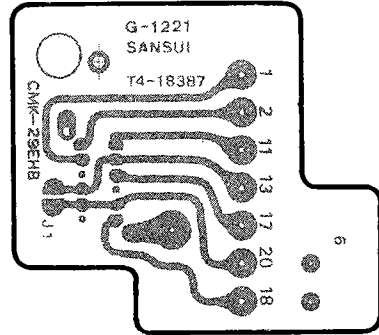

Parts List

Parts No.	Stock No.	Description
S10		Slide Switch, Play-Rec.
S13		Leaf Switch, Play

3) G-1229 LED (B) Circuit Board

(Stock No. 7595690) (SC-3100/3110)
 (Stock No. 7595740) (SC-2100/2110)

Conductor Side



Parts List

Parts No.	Stock No.	Description
LD603	0319070	TLR-102, REC
LD604	0319070	TLR-102, PEAK (SC-3100/3110)

6) G-1226 Switch Circuit Board

(Stock No. 7595960) (SC-3100/3110)
 (Stock No. 7595730) (SC-2100/2110)

Conductor Side

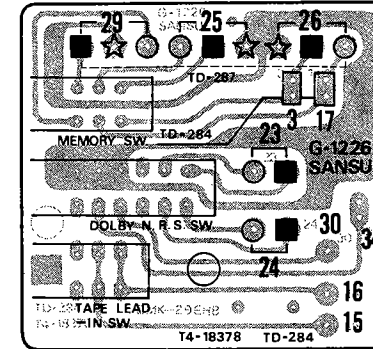

Parts List

Parts No.	Stock No.	Description
S06 ~ 08	1131510	3-Gang Push Switch

7) G-1228 LED (A) Circuit Board

(Stock No. 7595680)

Conductor Side

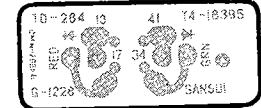

Parts List

Parts No.	Stock No.	Description
LD601	0319080	TLG-102, Dolby
LD602	0319070	TLR-102, Lead-In

4) G-1224 Input-Output Circuit Board (Stock No. 7595650)

Conductor Side

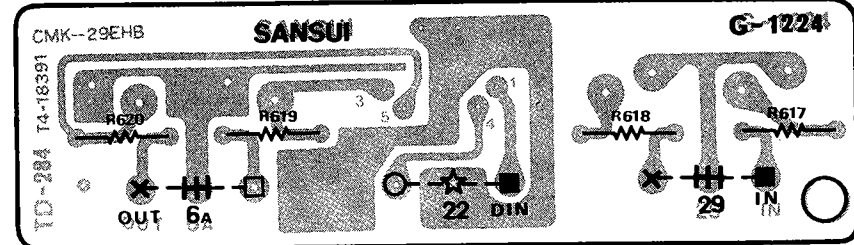

Parts List

Parts No.	Stock No.	Description
	7595650	Input-Output Jack A'ssy

SCHEMATIC DIAGRAM

SC-2100/2110

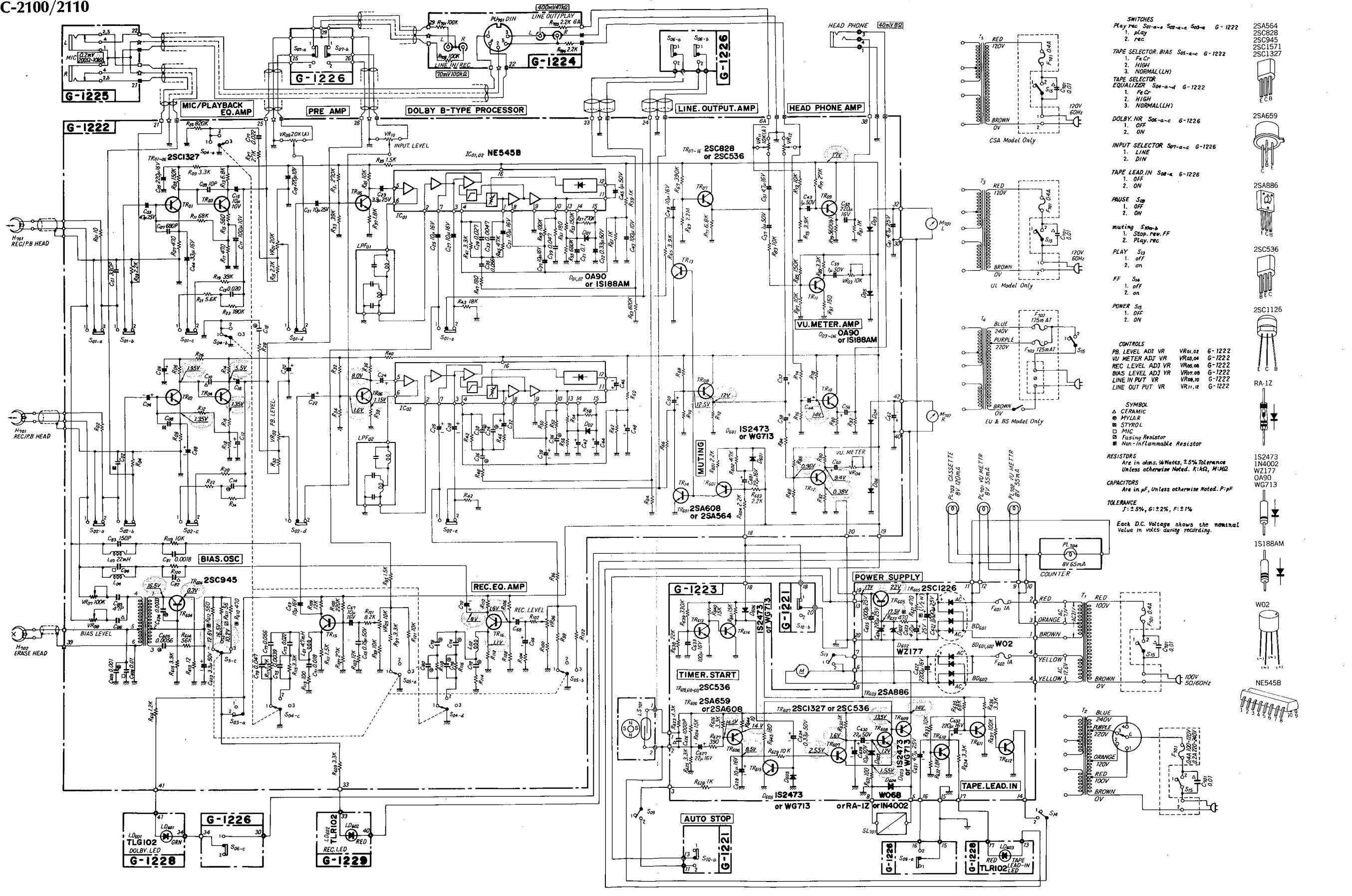

- SWITCHES**
- Play rec S01-a-e S02-a-e S03-a-e G-1222
 - 1. play
 - 2. rec
- TAPE SELECTOR BIAS S05-a-c G-1222**
1. Fe Cr
 2. HIGH
 3. NORMAL (LH)
- TAPE SELECTOR EQUALIZER S04-a-d G-1222**
1. Fe Cr
 2. HIGH
 3. NORMAL (LH)
- DOLBY NR S06-a-c G-1226**
1. OFF
 2. ON
- INPUT SELECTOR S07-a-c G-1226**
1. LINE
 2. DIN
- TAPE LEAD IN S08-e G-1226**
1. OFF
 2. ON
- PAUSE S09 G-1226**
1. OFF
 2. ON
- Muting S10-b G-1226**
1. Stop, rev. FF
 2. Play, rec
- PLAY S13 G-1226**
1. off
 2. on
- FF S14 G-1226**
1. off
 2. on
- POWER S15 G-1226**
1. OFF
 2. ON

- CONTROLS**
- PB. LEVEL ADJ VR VR01,02 G-1222
 - VU METER ADJ VR VR03,04 G-1222
 - REC. LEVEL ADJ VR VR05,06 G-1222
 - BIAS LEVEL ADJ VR VR07,08 G-1222
 - LINE IN PUT VR VR09,10 G-1222
 - LINE OUT PUT VR VR11,12 G-1222
- SYMBOL**
- ▲ CERAMIC
 - △ MYLAR
 - STYROL
 - MIC
 - ▭ Fusing Resistor
 - ▨ Non-inflammable Resistor

- RESISTORS**
- Are in ohms, 1/4 Watts, ±5% Tolerance
Unless otherwise noted. R:10K, M:1M, Ω
- CAPACITORS**
- Are in μF, Unless otherwise noted. P:pF
- TOLERANCE**
- J:±5%, G:±2%, F:±1%
- Each D.C. Voltage shows the nominal value in volts during recording.

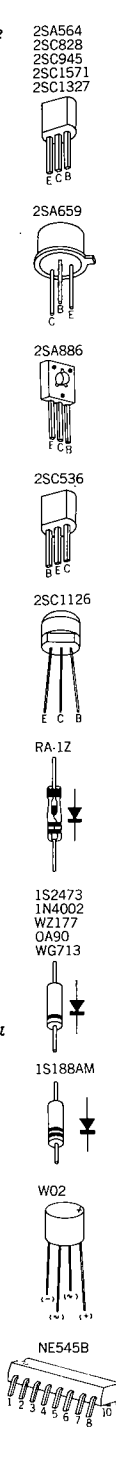

1
2
3
4
5

2) SC-3100/3110

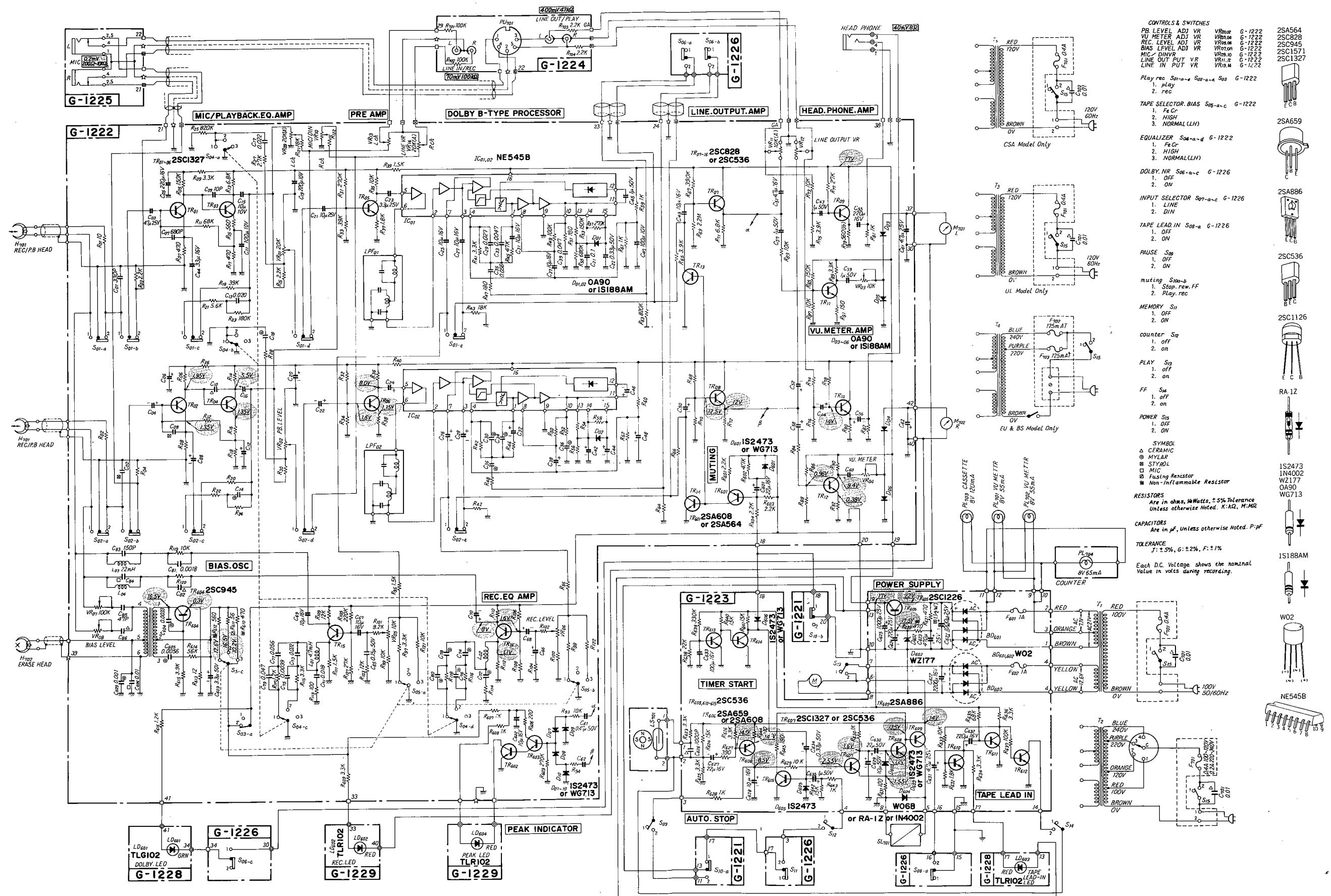

- CONTROLS & SWITCHES**
- PB LEVEL ADJ VR VR100 6-1222 2SA564
 - VU METER ADJ VR VR105 6-1222 2SC828
 - REC. LEVEL ADJ VR VR106 6-1222 2SC945
 - BIAS LEVEL ADJ VR VR107 6-1222 2SC1571
 - MIC/DINVR VR110 6-1222 2SC1327
 - LINE OUT PUT VR VR112 6-1222
 - LINE IN PUT VR VR114 6-1222
- Play rec S01-a S02-a S03 G-1222
 1. play
 2. rec
- TAPE SELECTOR BIAS S05-a-c G-1222
 1. F.C.
 2. HIGH
 3. NORMAL(LH)
- EQUALIZER S04-a-d G-1222
 1. F.C.
 2. HIGH
 3. NORMAL(LH)
- DOLBY NR S06-a-c G-1226
 1. OFF
 2. ON
- INPUT SELECTOR S07-a-c G-1226
 1. LINE
 2. DIN
- TAPE LEAD IN S08-a G-1226
 1. OFF
 2. ON
- PAUSE S09
 1. OFF
 2. ON
- Muting S10-a
 1. Stop,rew.FF
 2. Play,rec
- MEMORY S11
 1. OFF
 2. ON
- counter S12
 1. off
 2. on
- PLAY S13
 1. off
 2. on
- FF S14
 1. off
 2. on
- POWER S15
 1. OFF
 2. ON
- SYMBOLS**
 Δ CERAMIC
 ⊙ MYLAR
 ⊠ STYROL
 ⊞ MIC
 ⊞ Fusing Resistor
 ⊞ Non-inflammable Resistor
- RESISTORS**
 Are in ohms, W Watts, % Tolerance
 Unless otherwise noted. K=1K, M=1M
- CAPACITORS**
 Are in pF, Unless otherwise noted. P=pF
- TOLERANCE**
 J: ±5%, G: ±2%, F: ±1%
- Each DC Voltage shows the nominal Value in volts during recording.

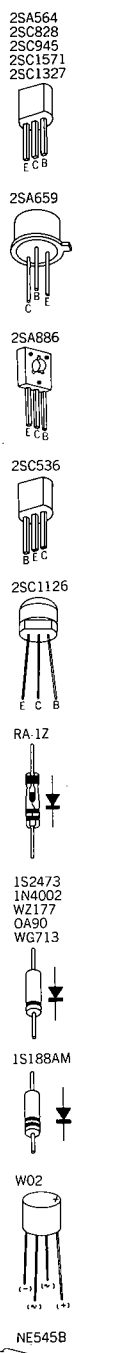

1
 2
 3
 4
 5

OTHER PARTS/Disassembly of the Mechanism Ass'y

- ① ~ ③①
- ③② ~ ⑥①
- ⑥② ~ ⑨①
- ⑨② ~ ①①①

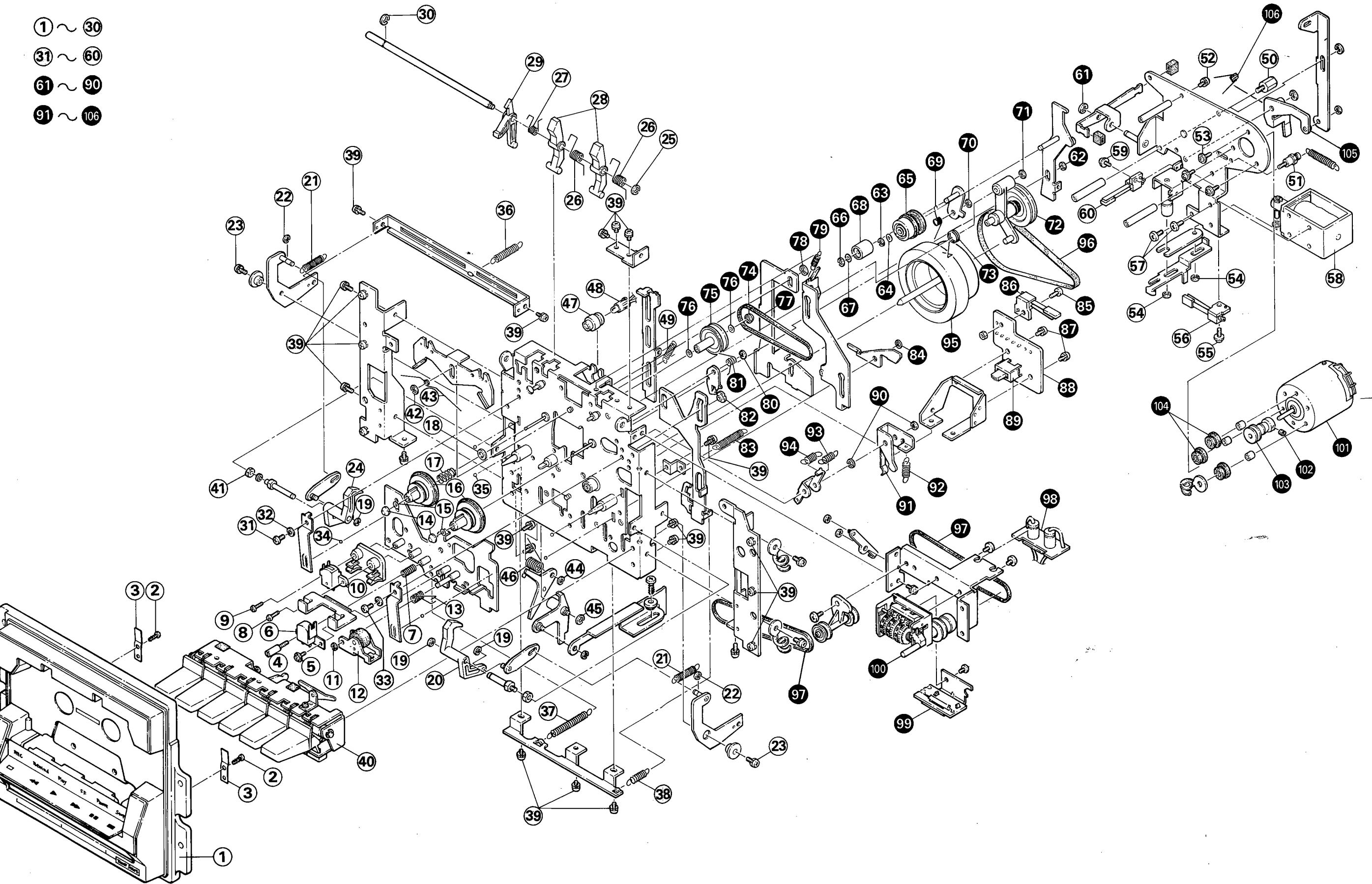

MECHANISM Ass'y (Stock No. 7160130 (SC-3100) (Stock No. 7160150 (SC-2100)
(Stock No. 7160160 (SC-3110) (Stock No. 7160170 (SC-2110)

Parts List

Parts No.	Stock No.	Description	Parts No.	Stock No.	Description
1	7010170	Mechanism Cover Ass'y	54	5151011	E Type Washer, 2.5φ
2	5103502	P Type Screw, M2 x 6	55	5109920	W Type Screw, M2.6 x 5
3	6400150	Plate Spring	56	1190560	Leaf Switch, pause
4	5160350	SS Type Screw(brass), head adjustment	57	5103042	B Type Screw, M3 x 5
5	5103004	P Type Screw, M2 x 6	58	4340160	Plunger Solenoid
6	4536020	REC/P.B Head (SC-2100/2110)	59	5109920	W Type Screw, M2.6 x 5
7	6901100	Spring, head adjustment	60	1190560	Leaf Switch, FF
8	5103044	P Type Screw, M2 x 8	61	5151005	E Type Washer, 3.2φ
9	5103004	P Type Screw, M2 x 6	62	5151011	E Type Washer, 2.5φ
10	4526010	Erase Head	63	5151002	E Type Washer, 2φ
11	5151002	E Type Washer, 2φ	64	5180410	P Type Washer, 2.5φ
12	7060160	Pinch Roller Arm Ass'y	65	7060170	Idler (A) Ass'y
13	6901180	Spring, pinch roller	66	5151001	E Type Washer, 1.5φ
14	5370090	Cap	67	5180430	P Type Washer, 2.1φ
15	5180380	P Type Washer, 1.8φ	68	7060180	Idler (B) Ass'y
16	7150080	Reel Hub (B) Ass'y (2)	69	6901200	Spring, idler (B) arm
17	6901340	Spring, back tension	70	5151002	E Type Washer, 2φ
18	5180490	P Type Washer, 6.2φ	71	5151011	E Type Washer, 2.5φ
19	5151011	E Type Washer, 2.5φ	72	7060240	Tension Arm Ass'y
20	5260390	Right Nail, cassette holder	73	6901350	Spring, roller arm
21	6901440	Spring, nail	74	5370090	Cap
22	5151002	E Type Washer, 2φ	75	7060200	Idler Ass'y
23	5107812	BSA Type Screw, M2.6 x 6	76	5180420	P Type Washer, 1.6φ
24	5260400	Left Nail, cassette holder	77	6030140	Tension Belt
25	5151011	E Type Washer, 2.5φ	78	5151011	E Type Washer, 2.5φ
26	6901420	Spring, upper nail	79	6901130	Spring, FF Lever
27	6901430	Spring, rec nail	80	5151011	E Type Washer, 2.5φ
28	6500800	Upper Nail, cassette holder	81	6901160	Spring, pause rock plate
29	6500810	Rec Prevention Nail	82	5160300	Nut, M2.6
30	5151004	E Type Washer, 3φ	83	6901370	Spring, plunger extraction
31	5103022	P Type Screw, M2.6 x 4	84	5151011	E Type Washer, 2.5φ
32	5121320	S Type Washer, 2.6φ	85	5103025	P Type Screw, M2.6 x 8
33	5103023	P Type Screw, M2.6 x 5	86	1190550	Leaf Switch, motor
34	6540040	Steel Ball 2.5φ	87	5107812	BSA Type Screw, M2.6 x 6
35	6540030	Steel Ball 2φ	88	7595641	Muting Circuit Board Ass'y
36	6901450	Spring, arm bar	89	1110350	Slide Switch, muting
37	6901120	Spring, brake lever rod	90	5151002	E Type Washer, 2φ
38	6901190	Spring, pause lever rod	91	6500790	Plate Spring Lever, mute
39	5107811	BSA Type Screw, M2.6 x 4	92	6901460	Spring, mute
40	7050110	Control Button Ass'y (SC-2100/3100)	93	6901500	Spring, REWIND lever
41	7050130	Control Button Ass'y (SC-2110/3110)	94	6901170	Spring, FR lever
42	5110241	Hex. Nut, M3	95	7040200	Flywheel Ass'y
43	5151011	E Type Washer, 2.5φ	96	6030130	Capstan Belt
44	6901090	Spring, brake lever	97	6030160	Counter Belt
45	5151004	E Type Washer, 3φ	98	7690500	Leaf Switch Ass'y
46	5151011	E Type Washer, 2.5φ	99	0400610	Lamp, counter 8V 65mA
47	6901470	Spring, rec arm	100	5430100	Tape Counter (SC-2100/2110)
48	5600010	Lamp Tube	101	5430090	Tape Counter (SC-3100/3110)
49	0400580	Lamp, 8V 120mA cassette half	101	4320520	FG Servo Motor (SC-3100/3110)
50	6901080	Spring, rec lever rod	101	4320530	Electronically Controlled DC Motor (SC-2100/2110)
51	5160310	Hex. Screw, M2.6	102	5105502	SCT Type Screw, motor pulley
52	5160330	Hex. Screw	103	6140120	Motor Pulley
53	5107812	BSA Type Screw, M2.6 x 6	104	5500540	Flowting Rubber, motor
	5107911	P Type Screw, M2.6 x 7	105	7050150	Pause lock release arm Ass'y
	5120121	P Type Washer, 2.6φ	106	6901060	Spring, Paus lock release arm Ass'y

Abbreviations

1. Pan Head Tapping ScrewPT Type	5. Pan Head SEMS B ScrewPSB Type	9. Flat Counter Sunk Wood ScrewFC Type	13. Binding Head SEMS B ScrewBSB Type	17. Toothed Lock Washer (External)TLE Washer
2. Washer Head Tapping ScrewWT Type	6. Binding Head SEMS F ScrewBSF Type	10. Round Head Wood ScrewRH Type	14. Spring WasherS Type	18. Wave Washer
3. Pan Head ScrewP Type	7. Binding Head ScrewB TYPE	11. Hex. Socket SetscrewSC Type	15. Plain WasherP Type	19. Hexagon Nut H Type Nut
4. Pan Head SEMS A ScrewPSA Type	8. Flat Counter Sunk Head ScrewF Type	12. Slot Type SetscrewSS Type	16. Retaining Ring (E Washer).....E Type	

2) Front View

• SC-3100

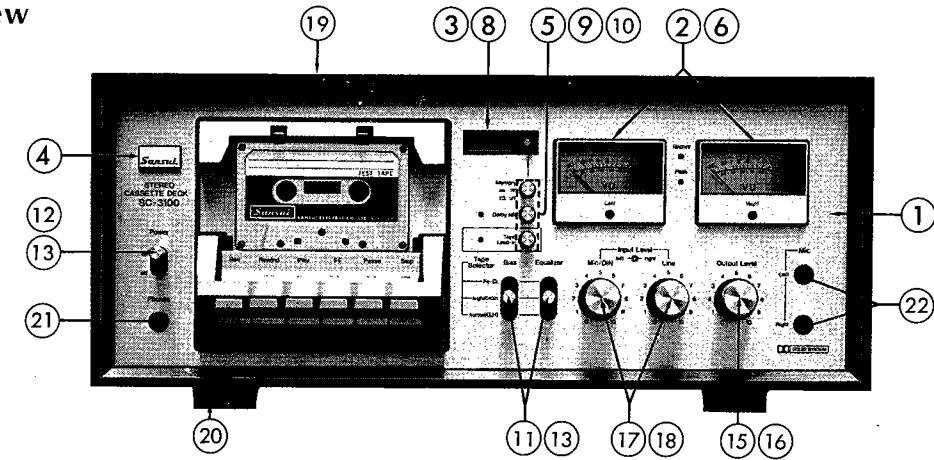

• SC2100

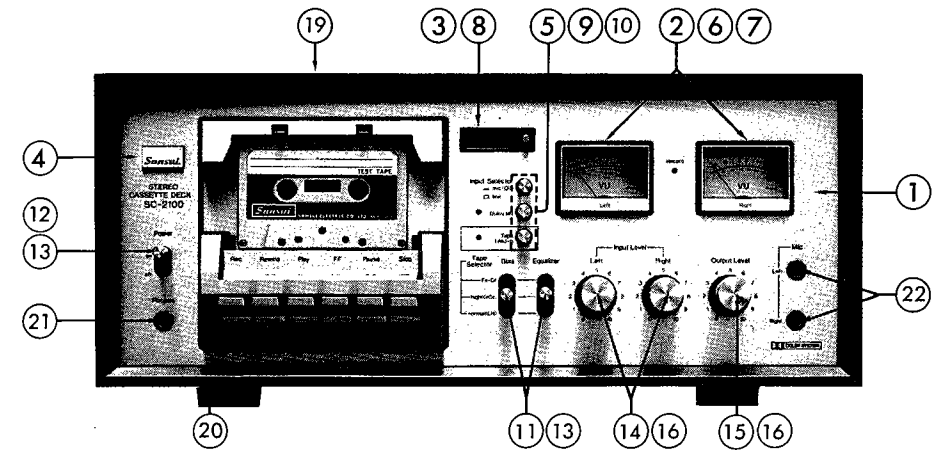

Parts List

Parts No.	Stock No.	Description	Parts No.	Stock No.	Description
1	7000170	Front Panel Ass'y (SC-3100)	13	7100010	Knob, Lever Switch (SC-2100/3100)
	7000200	Front Panel Ass'y (SC-3110)		5320520	Knob, Lever Switch (SC-2110/3110)
	7000180	Front Panel Ass'y (SC-2100)	14	VR09, 10	1000350 Volume 10kΩ (A) Input Level (SC-2100/2110)
	7000210	Front Panel Ass'y (SC-2110)	15	VR11, 12	1011140 Volume 10kΩ (A) x 2 Output Level
	5300780	Front Panel (SC-3100)	16	5310290	Knob, Input-Output Volume (SC-2100/3100)
	5301140	Front Panel (SC-3110)		5310380	Knob, Input-Output Volume (SC-2110/3110)
	5300800	Front Panel (SC-2100)	17	VR09, 10, VR13, 14	1020290 Volume, 20kΩ (A) x 2 Line, Mic, (SC-3100/3110)
	5301150	Front Panel (SC-2110)	18	5318300	Knob, Line Mic Volume (outer) (SC-3100)
2	5060330	Meter Frame		5310390	Knob, Line Mic Volume (outer) (SC-3110)
3	5060280	Counter Frame		5310310	Knob, Line Mic Volume (inner) (SC-3100)
4	5332080	Sansui Mark		5310400	Knob, Line Mic Volume (inner) (SC-3110)
5	6906410	Push Button Guide	19	5740230	Wood Case (SC-2100/3100)
6	M01, 02	VU Meter (SC-2100/2110)		5000050	Bonnet (SC-2110/3110)
	4301220	VU Meter (with Lamp)	20	5510120	Leg
	4301210	VU Meter (with Lamp) (SC-3100/3110)	21	5140424	RW Type Screw 3.1 x 14, Leg
7	0400590	Lamp 8V 120mA, VU Meter (SC-2100/2110)	22	2430290	Head Phone Jack
8	4330090	Tape Counter Ass'y (SC-3100/3110)		2430330	Mic Jack
	5430100	Tape Counter Ass'y (SC-2100/2110)			
9	5320450	Push Button Ass'y (SC-2100/3100)			
	5320530	Push Button Ass'y (SC-2110/3110)			
10	6906410	Spring, Push Button			
11	1171240	Lever Switch, Equalizer, Bias			
12	1171670	Lever Switch, Power XX			
	1171680	Lever Switch, Power UL, CSA			
	1171660	Lever Switch, Power BS, EU			

Top View

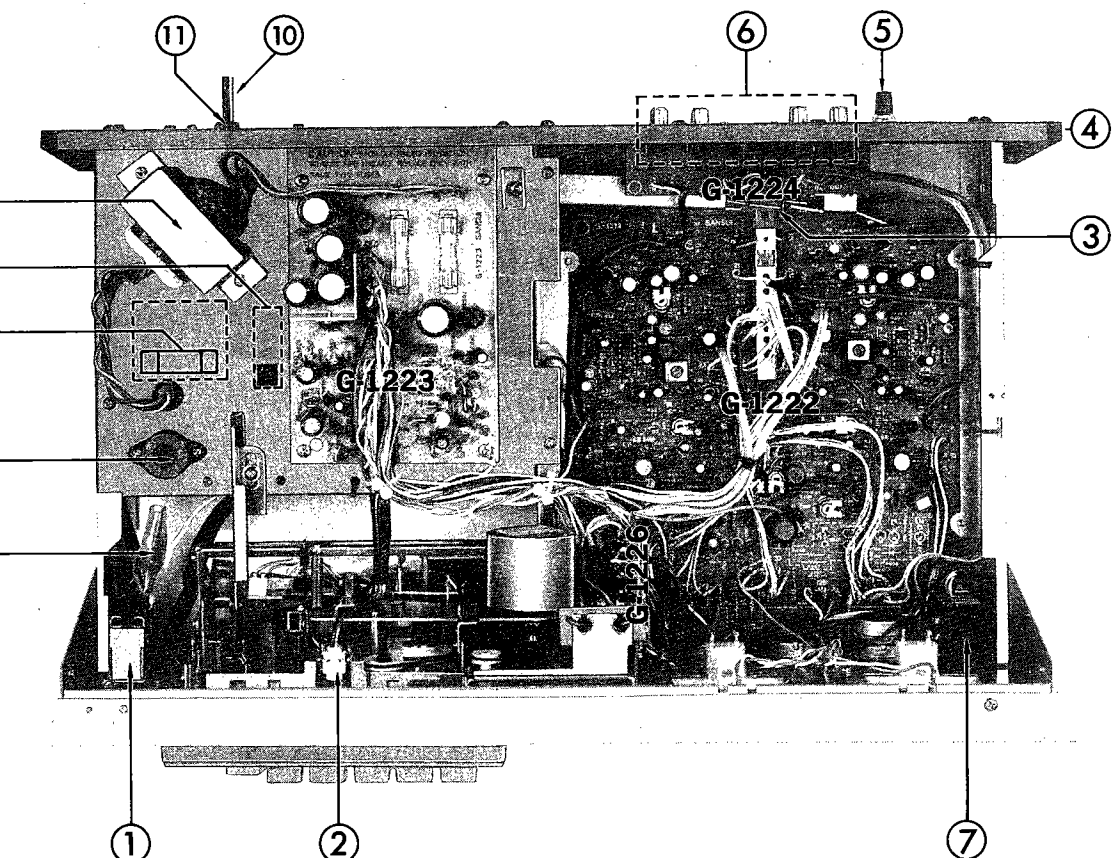

List

Parts No.	Stock No.	Description
F03	1171670	Power Switch XX
	1171680	Power Switch UL, CSA
	1171660	Power Switch BS, EU
	0400580	Lamp, 8V 120mA cassette half
	6901490	REC Plate Spring
	5300750	Rear Panel XX, UL, CSA
	5300790	Rear Panel BS, EU
	2230150	Ground Terminal
	7595650	Input-Output Jack Ass'y
	2430330	Mic Jack
F03	6901480	Spring, REC lever rod
	0431331	Fuse 0.4A 250V (AC100V ~ 120V) XX, UL, CSA
	0431241	Fuse 0.2A 250V (AC200V ~ 240V) XX
	0430950	Fuse 125mA 250V EU, BS

No.	Parts No.	Stock No.	Description
10		3800010	AC Cord XX, UL, CSA
		3800121	AC Cord EU, BS
11		3910600	Strain releaf
		4002710	Power Transformer XX
12	PT01	4002712	Power Transformer UL, CSA
		4002714	Power Transformer EU, BS
		2410820	Voltage Selector Plug XX
		2411250	Voltage Selector Socket XX
13		2411240	Voltage Selector EU, BS
		0659801	Line bypass capacitor XX, UL
		5616220	Capacitor cover, C707 XX, UL
14	C701	0635107	Line bypass capacitor CSA
		5616340	Capacitor cover C702 CSA

8. PACKING LIST

Parts No.	Stock No.	Description
1	9010110	Dust Cover Case
2	9110100	Polyethylene Bag
3	9020020	Stylofoam Packing (SC-2100/3100)
	9020040	Stylofoam Packing (SC-2110/3110)
4	9000420	Carton Case (SC-2100)
	9000450	Carton Case (SC-2110)
	9000410	Carton Case (SC-3100)
	9000440	Carton Case (SC-3110)
5	5996080	Curl Stopper

9. ACCESSORY PARTS LIST

Parts No.	Stock No.	Description
	9202850	Operating Instructions (SC-3100)
	9202860	Operating Instructions (SC-3110)
	9202820	Operating Instructions (SC-2100)
	9202830	Operating Instructions (SC-2110)
	9230180	Schematic Diagram (SC-3100/3110)
	9230190	Schematic Diagram (SC-2100/2110)
	9430031	Head Cleaning Pen
	5010070	Dust Cover
	3810280	PJP Cord

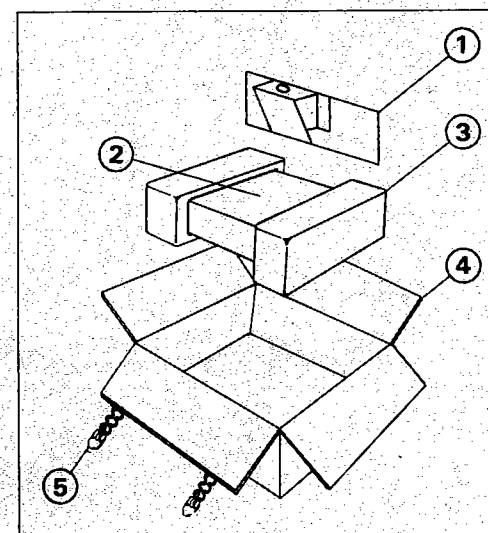

MEMO

NOTE:
AS to U.L., C.S.A., B.S., ES and XX marked in the Parts Lists, note the followings:
U.L., C.S.A. Approved parts used in the unit which is applicable to the U.S. and Canada under safety standard.
B.S. Approved parts used in the unit which is applicable to British under safety requirement.
E.U. Approved parts used in the unit which is applicable to Sweeden, Denmark, Norway, Finland, West Germany, and Switzerland under safety requirement.
XX Parts used in the unit which is applicable to other countries excepting mentioned above.
* Parts unspecified such as CSA, UL, EU & XX in "Description" are common parts.

Sansui

SANSUI ELECTRONICS CORPORATION: 55-11 Queens Blvd. Woodside, N.Y. 11377 U.S.A.
333 West Alondra Blvd. Gardena, California 90247 U.S.A.
3036 Koapaka St. Honolulu, Hawaii 96819 U.S.A.

SANSUI AUDIO EUROPE N.V.: North Trade Bldg (9th floor) Noorderlaan 133-Bus 1,2030 Antwerp, Belgium
SANSUI AUDIO EUROPE S.A.: Arabella center, 6 Frankfurt AM Main, Lyoner Strasse 44-48, West Germany

SANSUI ELECTRIC COMPANY LTD.: 14-1, Izumi 2-chome, Suginamiku, Tokyo 168 Japan PHONE: (03) 323-1111/TELEX:232-2076

SM086 Printed in Japan (876230M)