

SERVICE MANUAL

STEREO CASSETTE TAPE DECK

SANSUI SC-737



Sansui

SANSUI ELECTRIC CO., LTD.

This service manual is designed for service engineers to repair, adjust, maintain and order the replacement parts of the SC-737 correctly. When ordering the parts, use the stock number and parts name specifically referring to the Exploded Views, Parts Location and Parts List.

For general usage and maintenance of the unit, please refer to the Operating Instructions attached with the unit.

TABLE OF CONTENTS

<u>Section</u>	<u>Title</u>	<u>Page</u>	<u>Section</u>	<u>Title</u>	<u>Page</u>
1. SPECIFICATIONS		2			
2. BLOCK DIAGRAM AND LEVEL DIAGRAMS		3			
2-1.	Block Diagram	3			
2-2.	Level Diagrams	4			
3. ADJUSTMENTS		5			
3-1.	Head Adjustment	5			
3-1-1.	REC/PB Head Adjustment	5			
3-1-2.	Erase Adjustment	5			
3-2.	Playback Level Adjustment	5			
3-3.	VU Meter Level Adjustment	5			
3-4.	Recording Bias Adjustment	5			
3-4-1.	Setting TAPE SELECTOR Switch to NORMAL	5			
3-4-2.	Setting TAPE SELECTOR Switch to CHROMIUM	6			
3-5.	REC/PB Level Adjustment	6			
3-5-1.	Setting TAPE SELECTOR Switch to NORMAL	6			
3-5-2.	Setting TAPE SELECTOR Switch to CHROMIUM	7			
3-6.	Dolby Circuit Adjustment	7			
3-7.	Bias MPX Filter Adjustment	7			
3-8.	Pinch-roller Pressure Adjustment	7			
3-9.	Torque Adjustment	7			
4. TROUBLESHOOTING CHART		8			
4-1.	TROUBLESHOOTING ON THE ELECTRICAL SECTION	8			
4-1-1.	Troubleshooting on Power Supply Section	8			
4-1-2.	Troubleshooting on Recording System	8, 9			
4-1-3.	Playback System Troubles	9, 10			
4-1-4.	Troubles in Both Recording/ Playback Mode	10			
			4-1-5.	Auto Shut-off Circuit Troubles	10
			4-1-6.	Dolby Circuit Troubles	10
			4-2.	TROUBLESHOOTING ON THE MECHANICAL SECTION	11
			4-2-1.	FAST FORWARD Inoperative	11
			4-2-2.	REWIND Inoperative	11
			4-2-3.	PAUSE Inoperative	11
			4-2-4.	Incorrect Tape Speed	11
			4-2-5.	Excessive Wow and Flutter	11
			4-2-6.	Incorrect Brake	11
			4-2-7.	No Tape Movement	11
			5. PARTS LOCATIONS AND PARTS LISTS	12	
			5-1.	G-1159 Level Control Circuit Board	12
			5-2.	G-1127 REC/PB Amplifier Circuit Board	13, 14
			5-3.	G-1167 Dolby Circuit Board	15, 16
			5-4.	G-1166 Auto Shut-off Circuit Board	16
			5-5.	G-1168 Power Supply Circuit Board	16
			5-6.	G-1160 Switch Circuit Board	16
			5-7.	G-1180 CdS Circuit Board	16
			5-8.	G-1185 Fuse Circuit Board	16
			5-9.	Other Parts	17
			6. DISASSEMBLY WITH EXPLODED VIEWS, PART LOCATIONS AND PARTS LISTS	17	
			6-1.	Disassembly of the Cabinet	17, 18
			6-2.	Disassembly of the Electrical Section	19, 20
			6-3.	Disassembly of the Mechanism (Top View)	21, 22
			6-4.	Disassembly of the Mechanism (Bottom View)	23, 24
			7. SCHEMATIC DIAGRAM	25	
			8. REPLACEMENT OF MAIN PARTS	26	
			9. PACKING LIST	26	
			10. ACCESSORY PARTS LIST	26	

1. SPECIFICATIONS

TRACK	4-track (2-ch. stereo)
TAPE SPEED.....	4.8cm/sec (1 7/8 ips.)
TAPE STANDARD	PHILIPS cassette standard
HEADS	REC/PB ferrite head ERASE ferrite head
MOTOR	hysteresis synchronous type
TAPE DRIVING SYSTEM ..	belt driving system
WOW AND FLUTTER	within 0.11% (W.R.M.S.)
TAPE SPEED ACCURACY ..	within $\pm 1.5\%$
FAST WIND TIME	within 75 seconds (C-60)
FREQUENCY RESPONSE (REC/PB)	
NORMAL (L. H) TAPE....	30 to 13,000Hz (35 to 11,000Hz ± 3.0 dB)
CHROMIUM TAPE.....	30 to 16,000Hz (35 to 14,000Hz ± 3.0 dB)
SIGNAL TO NOISE RATIO (REC/PB)	
CHROMIUM TAPE (without dolby noise reduction effect)	better than 50dB (weighted)
DOLBY NOISE REDUCTION EFFECT	
.....	better than 8dB (above 5kHz)
CHANNEL SEPARATION ..	better than 38dB at 1,000Hz
ERASURE FACTOR	more than 60dB at 1,000Hz
INPUT SENSITIVITY AND IMPEDANCE (0VU, 1,000Hz)	
MIC (LEFT, RIGHT).....	0.5mV 10k Ω
MIC (CENTER)	0.5mV 10k Ω
LINE	70mV 100k Ω
DIN	14mV 30k Ω
OUTPUT LEVEL (0VU 1,000Hz)	
LINE	0.56V
DIN	0.56V
HEADPHONES	0.12mW/8 Ω
BIAS FREQUENCY	85 kHz
OTHERS	
SEMICONDUCTORS	
TRANSISTORS	41
FETs	2
ZENER DIODES	2
DIODES	17
VARISTORS.....	6
CdS	1
POWER VOLTAGE	100, 117, 220, 240V, 50/60Hz
POWER CONSUMPTION. .	22W (rated)
DIMENSIONS	464mm (18 1/4") W, 121mm (4 3/4") H, 294mm (11 3/8") D
WEIGHT	8.1 kg (17.8 lbs) net, 10 kg (22 lbs) shipping

* Design and specifications subject to change without notice for improvements.

2. BLOCK DIAGRAM AND LEVEL DIAGRAMS

2-1. Block Diagram

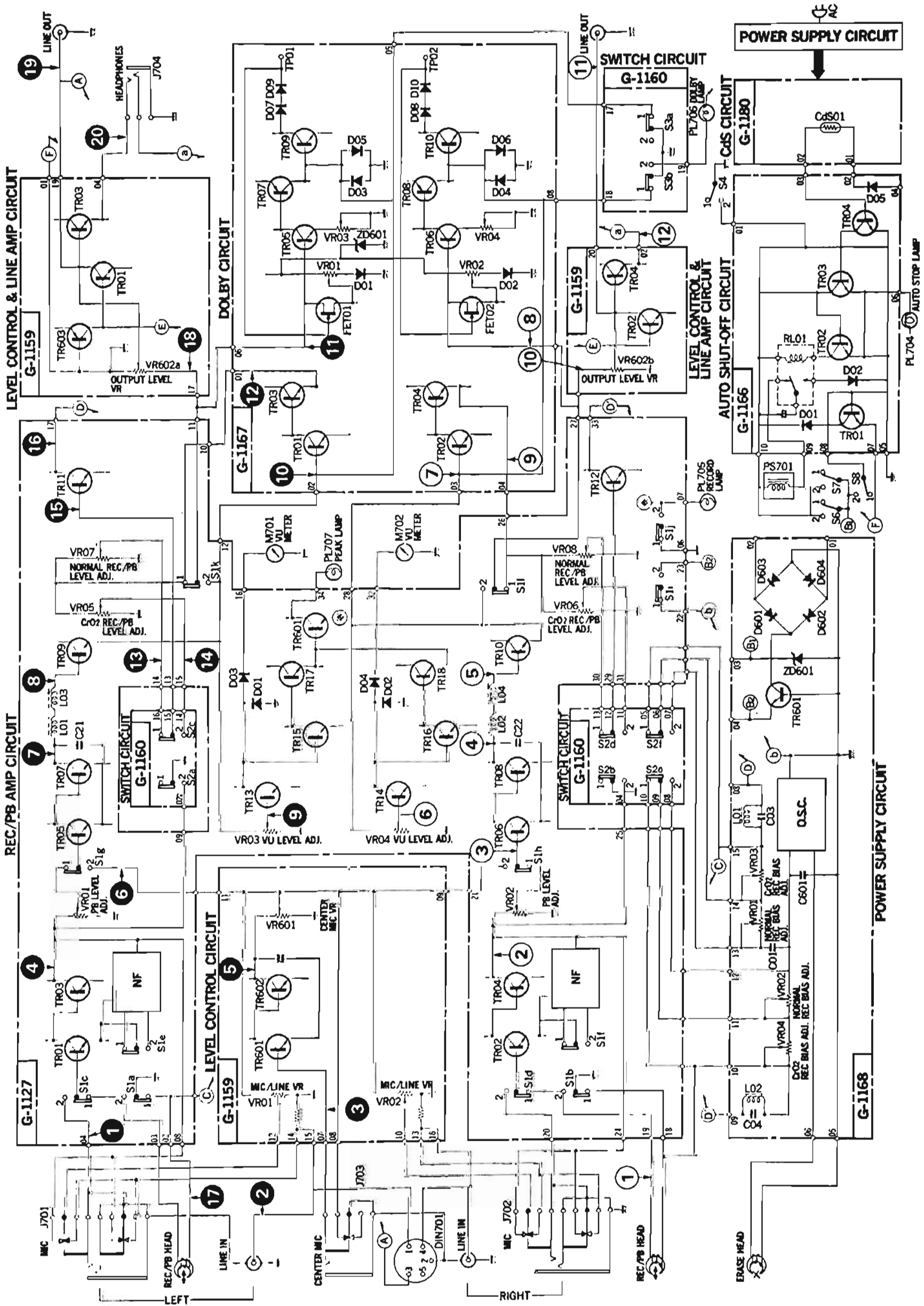

S10~k: REC PLAY SW S2a~f: TAPE SELECTOR SW S3a, b: DOLBY N.R SW S4: PAUSE SW S5: POWER SW S6: FAST FORWARD SW S7: REWIND SW S8: PLAY SW
 1. PLAY 1. NORMAL 1. OFF 1. OFF 1. OFF 1. OFF 1. OFF
 2. REC 2. CHROMIUM 2. IN 2. ON 2. ON 2. ON 2. ON

2-2. Level Diagrams

*Each number (1, 2, 3...) indicated in Level Diagrams undermentioned corresponds to the number in Block Diagram.

*Each number 1, 2, 3... → Recording Level

*Each number 1, 2, 3... → Playback Level

1. MIC/LINE volume control.....Maximum
2. CENTER MIC volume controlMaximum

3. OUTPUT LEVEL control.....Maximum

4. INPUT1kHz Sine Wave
(output impedance of 600Ω at an audio oscillator)

Note: Each voltage value is for reference and measured by a VTVM. In some recorders, the actual voltage value is in minor difference from the reference value.

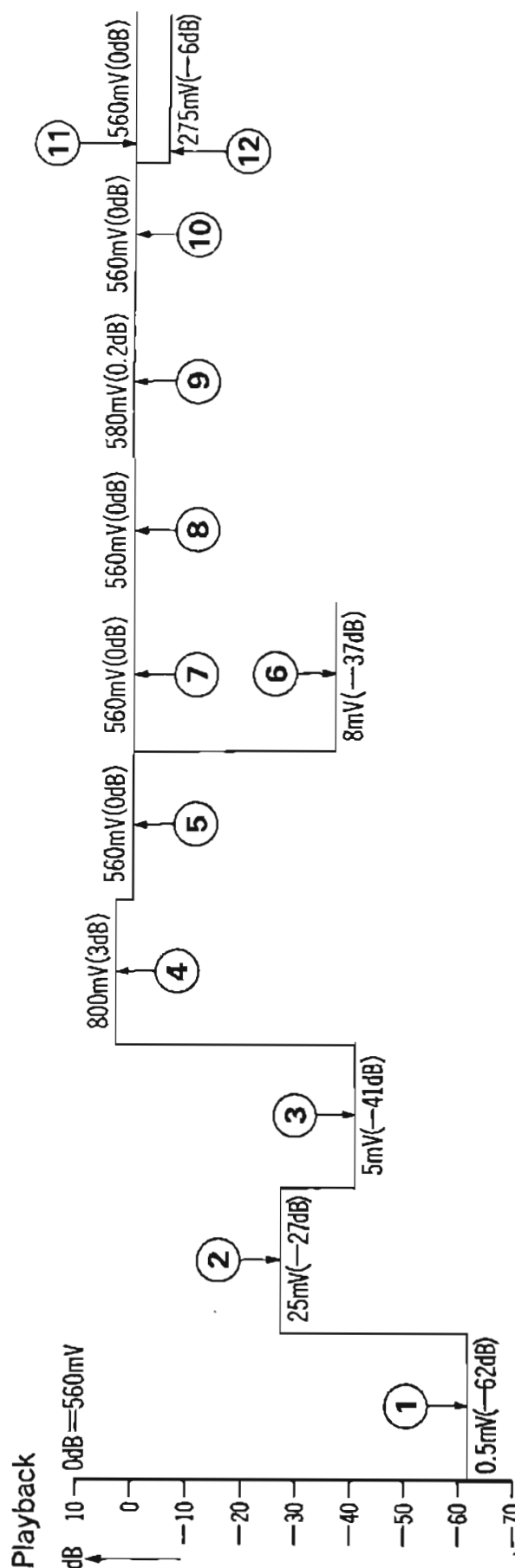
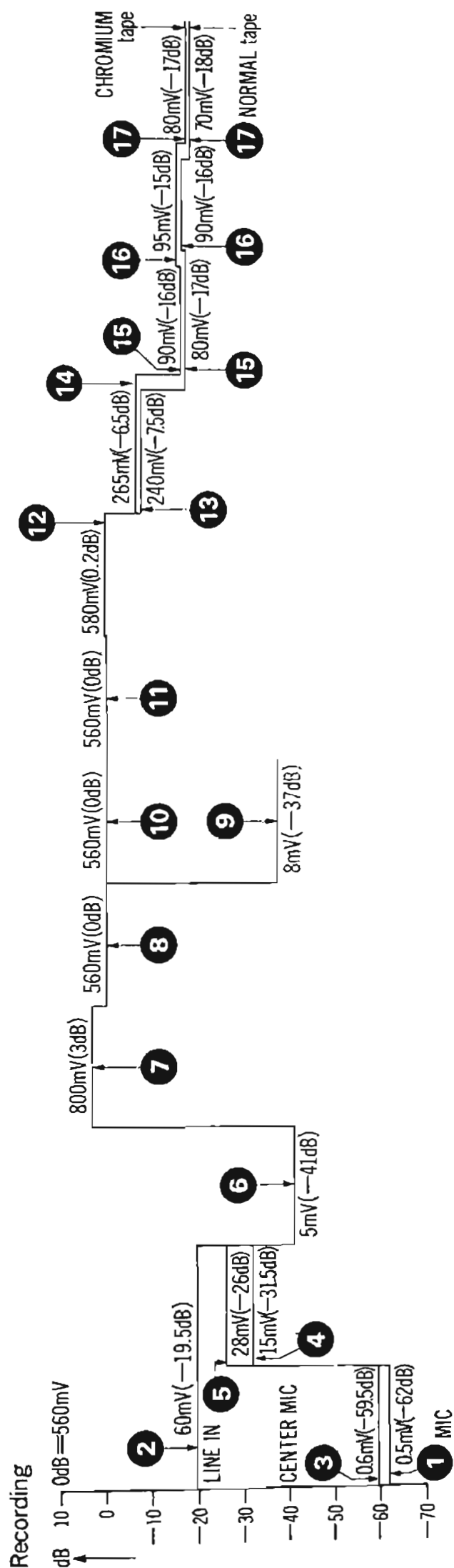

3. ADJUSTMENTS

*The List of Sansui Test Tapes

Name of test tape		Recorded Freq.	Description
NCT-L400 SCT-L400		400Hz	Playback level adjustment, VU meter level check
NCT-S3K SCT-S3K		3kHz	Speed, wow & flutter check
NCT-FCB6 SCT-FCB6			Recording bias adjustment, REC/PB level adjustment, All-over frequency (REC/ PB) check
NCT-FCR SCT-FCR			
(A)	(B)		
NCT-F63	SCT-F63	63Hz	Playback frequency check
NCT-F1K	SCT-F1K	1kHz	Playback frequency check
NCT-F10K	SCT-F10K	10kHz	Playback frequency check, REC/PB head adjustment

Note: The above test tapes in each column can be used in common each other, but on F63, F1k and F10k, use either ones in column (A) or column (B) separately due to different recorded levels between NCT- and SCT- tapes.

3-1. Head Adjustment (See Fig. 3-1)

*Notice: When replacing REC/PB Head, please follow the list below

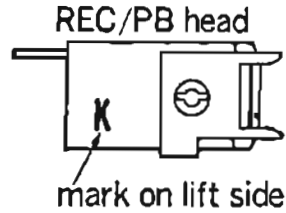
REC/PB head	Mark	Resistors to be Replaced	Parts No.
	K	4.7kΩ ¼W	F-1127 R ₁₉ , R ₂₀
	L	3.9kΩ ¼W	
	M	2.2kΩ ¼W	

3-1-1. REC/PB Head Adjustment

- 1) Set the OUTPUT LEVEL volume to maximum.
- 2) Connect a VTVM to the LINE OUTPUT terminals (L, R-ch).
- 3) Play back the 10 kHz test tape (SCT-F10K).
Adjust the azimuth adjusting screw for the maximum reading on the VTVM at both channels.

3-1-2. Erase Head Adjustment

- 1) Any adjustment on the erase head is not necessary.
* Confirm only that recorded signals on one channel of tape are completely erased or ones on another channel are not.

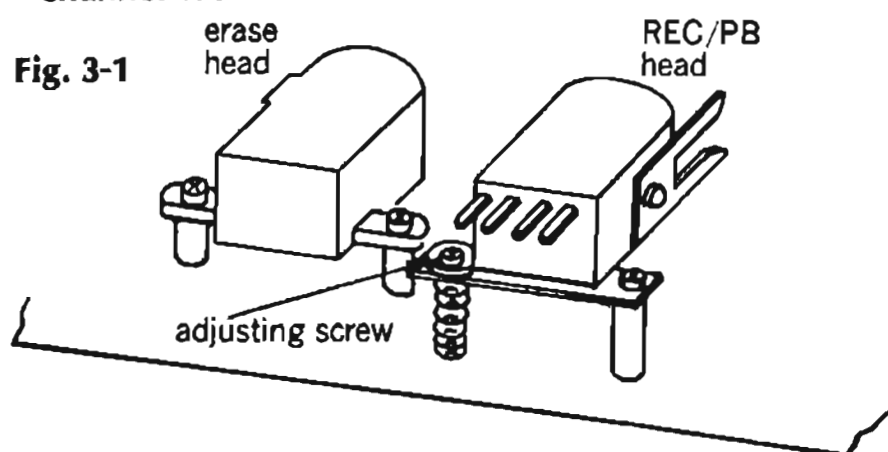

Fig. 3-1

3-2. Playback Level Adjustment

(See Fig. 3-3)

- 1) Set the OUTPUT LEVEL volume to maximum.
- 2) Connect a VTVM to the LINE OUTPUT terminals (L, R-ch).
- 3) Play back the 400 Hz test tape (SCT-L 400).
Adjust VR01 for L-ch and VR02 for R-ch on G-1127 so that the output level of playback signal on VTVM will indicate 560mV at 400Hz.
* Play back the 63 Hz, 1 kHz and 10 kHz test tapes (SCT-F63, SCT-F1K and SCT-F10K) and make sure that the both outputs are within 0± 3dB against that of 1kHz.

3-3. VU Meter Level Adjustment

(See Fig. 3-3)

- 1) Set the OUTPUT LEVEL and MIC/LINE LEVEL volumes to maximum.
- 2) Connect a VTVM to the LINE OUTPUT terminals (L, R-ch).
- 3) Supply the 1 kHz signal from an audio signal generator to the LINE INPUT terminals (L, R-ch).
- 4) Push on the PAUSE button and set the unit in the record mode.
- 5) Adjust the level volume of the audio signal generator for obtaining 560 mV on the VTVM.
- 6) Adjust VR03 for L-ch and VR04 for R-ch on G-1127 to obtain 0dB on the VU meters.

3-4. Recording Bias Adjustment

(See Fig. 3-2)

3-4-1. Setting TAPE SELECTOR Switch to NORMAL

- 1) Set the OUTPUT LEVEL and MIC/LINE LEVEL volumes to maximum.
- 2) Connect a VTVM to the LINE OUTPUT terminals (L, R-ch).
- 3) Supply the 1 kHz signal from an audio signal generator to the LINE INPUT terminals (L, R-ch).
- 4) Push on the PAUSE button and set the unit in the record mode using a Normal test tape (SCT-FCB6).
- 5) Adjust the level volume of the audio signal generator for obtaining 560mV on the VTVM.
* Make sure that the reading of the VU meter is 0dB.
- 6) Change the 1kHz signal from 560mV to 56mV (-20dB).
Push off the PAUSE button and record.
Then, change the signal from 1kHz to 10kHz (56mV) and record.
- 7) Play back the 1kHz and 10kHz signal, then confirm that difference of output levels between 1kHz and 10kHz is ±0dB (namely, confirm that the output levels of both signals which must be 56mV on VTVM respectively).

8) If the level of 10kHz signal is under 56mV, as compared with the level of 1kHz, turn VR01 for L-ch and VR02 for R-ch on G-1168 counterclockwise from conductor side.

If it is over 56mV, turn them clockwise from conductor side. When adjusting the above, repeat the steps 6), 7) until the difference of both output levels (1kHz and 10kHz) are 0dB (56mV) on VTVM.

3-4-2. Setting TAPE SELECTOR switch to CHROMIUM

- 1) Perform steps 1) through 3) of 3-4-1.
- 2) Push on the PAUSE button and set the unit in the record mode using a Chromium test tape (SCT-FCR).
- 3) Perform steps 5), 6) and 7) of 3-4-1.
- 4) If the level of 10kHz signal is under 56mV (0dB) on VTVM, turn VR03 for L-ch and VR04 for R-ch on G-1168 counterclockwise from conductor side. If it is over 56mV, turn them clockwise from conductor side. When adjusting above, repeat the step 3) until the difference of output levels (1kHz and 10kHz) are 0dB (56mV) on VTVM.

Fig. 3-2

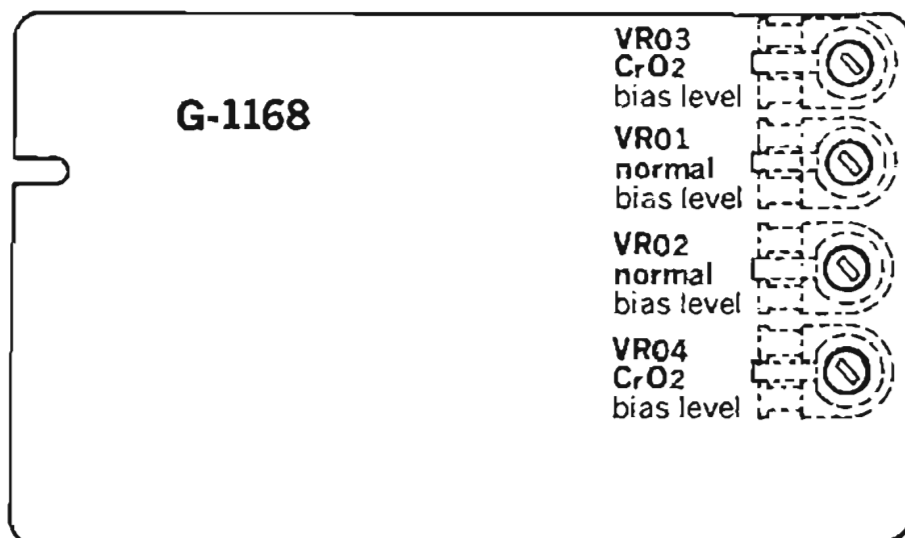

3-5. REC/PB Level Adjustment

(See Fig. 3-3)

3-5-1. Setting TAPE SELECTOR switch to NORMAL

- 1) Set the OUTPUT LEVEL and MIC/LINE LEVEL volumes to maximum.
- 2) Connect a VTVM to the LINE OUTPUT terminals (L, R-ch).
- 3) Supply the 1kHz signal from an audio signal generator to the LINE INPUT terminals (L, R-ch).
- 4) Push on the PAUSE button and set the unit in the record mode using a Normal test tape (SCT-FCB6).
- 5) Adjust the level volume for obtaining 56mV on the VTVM.
- 6) Push off the PAUSE button, then record the 1kHz signal.
- 7) Play back the 1kHz signal and confirm the output level of each channel which must be 56mV on VTVM.
- 8) If the indication of output level on each channel is under 56mV, turn VR07 for L-ch and VR08 for R-ch on G-1127 counterclockwise or if it is over 56mV, turn them clockwise from conductor side so that the output level 56mV may be obtained. Repeat the above steps 6), 7) a few times until the indication on VTVM will be exactly 56mV.

Fig. 3-3

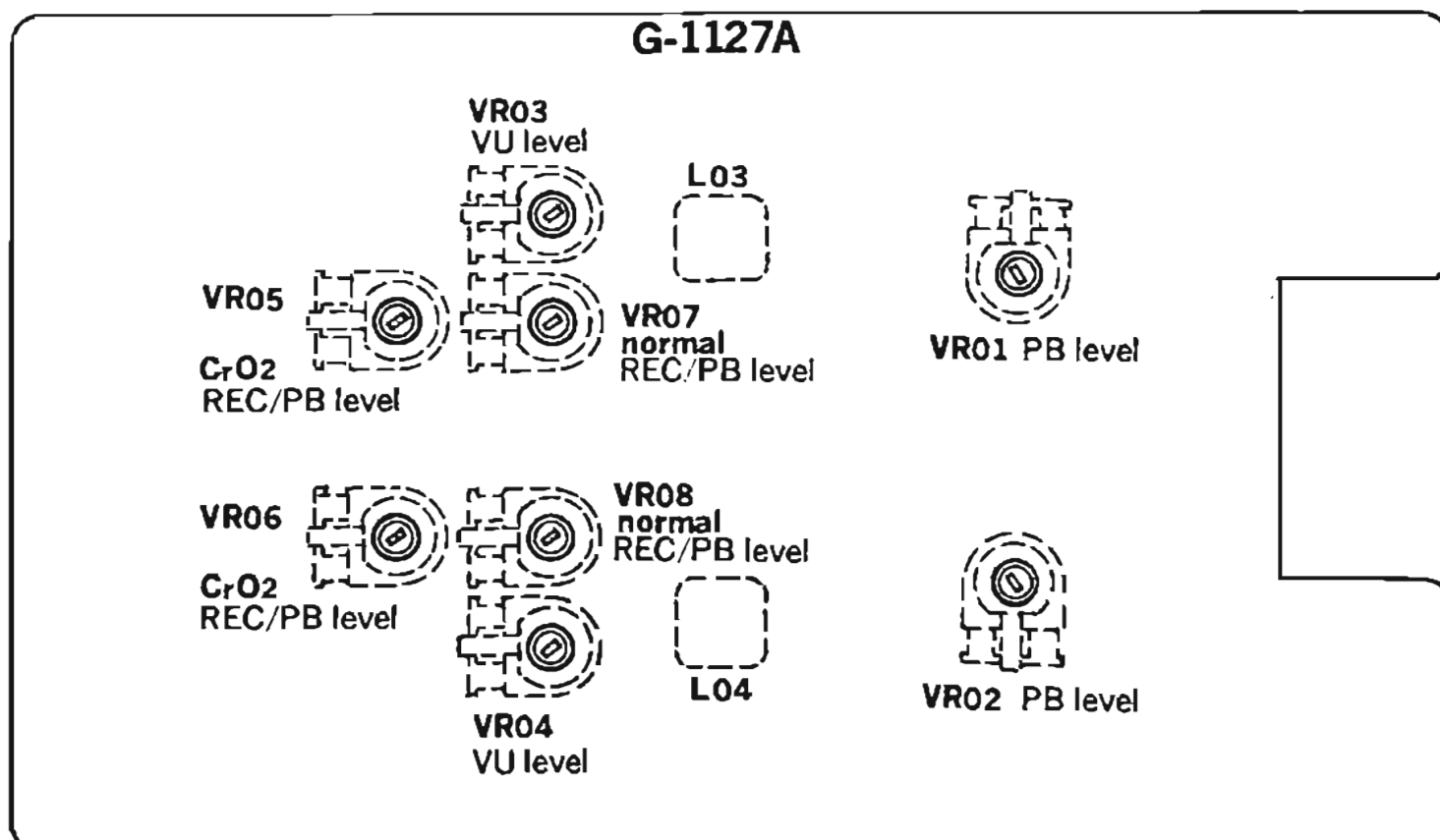

3-5-2. Setting TAPE SELECTOR switch to CHROMIUM

- 1) Perform steps 1) through 3) of 3-5-1.
- 2) Push on the PAUSE button and set the unit in the record mode using the Chromium test tape (SCT-FCR).
- 3) Perform steps 5), 6) and 7) of 3-5-1.
- 4) If the indication of output level on each channel is under 56mV, turn VR05 for L-ch and VR06 for R-ch on G-1127 counterclockwise or if it is over 56mV, turn them clockwise from conductor side so that the output level 56mV may be exactly obtained.
Repeat the above step 3) a few times until the indication on VTVM will be exactly 56mV.

3-6. Dolby Circuit Adjustment (See Fig. 3-4)

- 1) Set the MIC/LINE LEVEL volume to maximum and DOLBY switch to OUT.
- 2) Turn VR01 clockwise (viewed from the bottom side) and VR02 counterclockwise (viewed from the bottom side.)
- 3) Connect a VTVM between the terminal 01 and ground for L-ch, and terminal 04 and ground for R-ch on F-1167.
- 4) Supply the 5kHz signal from an audio signal generator to the LINE INPUT terminals (L, R-ch).
- 5) Push on the PAUSE button and set the unit in the record mode.
- 6) Adjust the output level volume of the audio signal generator for obtaining 17.5mV on the VTVM.
- 7) Ground TP01 and TP02 and set the DOLBY switch to IN.
- 8) Adjust VR03 for L-ch, and VR04 for R-ch on F-1167 until the VTVM reads 55.3mV (+10dB) higher position from 17.5mV.
- 9) Disconnect TP01 and TP02 from ground.
- 10) Adjust VR01 for L-ch, and VR02 for R-ch on F-1167 until the VTVM reads 40.9mV (-2dB) lower position from 55.3mV.
- 11) Ground TP01 and TP02 again.
Make sure that the VTVM connected between the terminal 01 and ground for L-ch, and the 04 and ground for R-ch reads 55.3mV (+2dB) higher position.

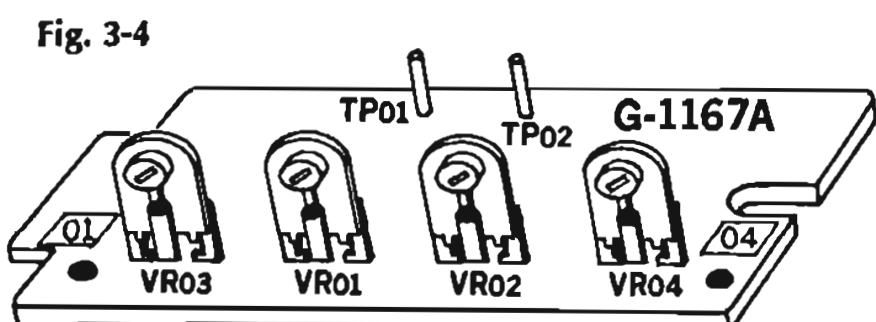

Fig. 3-4

3-7. Bias MPX Filter Adjustment (See Fig. 3-3)

*When replacing the REC/PB amp circuit board (G-1127), adjust the Bias MPX Filter.

- 1) Set the OUTPUT LEVEL and MIC/LINE LEVEL volumes to maximum.
- 2) Connect a VTVM to the LINE OUTPUT terminals (L, R-ch).
- 3) Supply the 19kHz, 10mV signal from an audio signal generator to the LINE INPUT terminals (L, R-ch).
- 4) Push on the PAUSE button and set the unit in the record mode.
- 5) Adjust L03 for L-ch and L04 for R-ch on G-1127 for obtaining the minimum reading on VTVM.

3-8. Pinch-roller Pressure Adjustment (See Fig. 3-5)

*After pushing on the PLAY button with or without cassette tape, perform the following procedures (power switch ON).

- 1) Hook the spring scale at point (A) of the roller arm as shown in Fig. 3-5.
- 2) Pull the spring scale eventually to the arrow direction until the pinch-roller stops running.
- 3) Slide the spring retainer (Part name, "Hook, pinch-roller spring") by loosening the screw so that the scale indicates $330 \pm 30g$.
- 4) Screw it up, then confirm that no considerable variation of the pressure indication on the scale is included in PLAYBACK and STOP process.

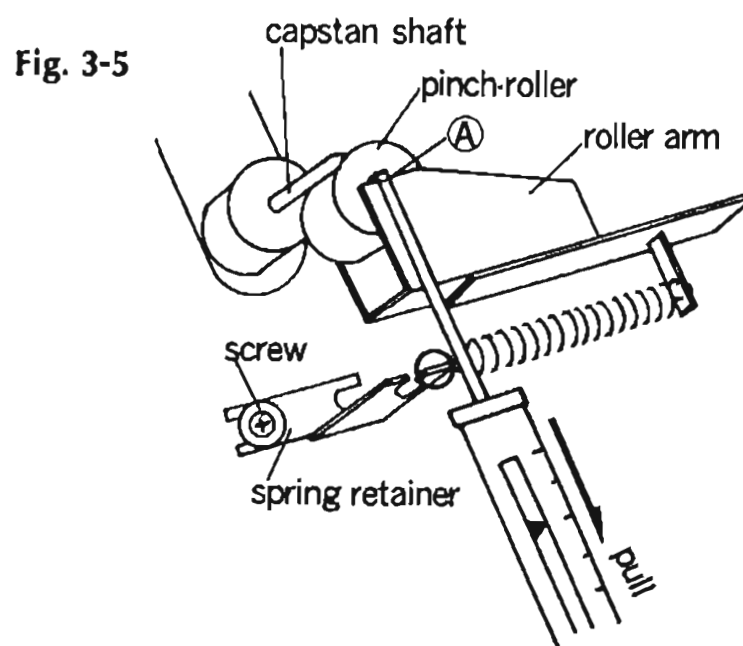

Fig. 3-5

3-9. Torque Adjustment

*No any torque adjustments are necessary.

Each torque is fixed as follows:

- Take-up torque (PLAYBACK) more than 38g-cm
- Take-up torque (FAST FORWARD)..... 60~110g-cm
- Take-up torque (REWIND) 60~110g-cm

4. TROUBLESHOOTING CHART

4-1. TROUBLESHOOTING ON THE ELECTRICAL SECTION

Symptom	Check Point	Cause & What to Do
4-1-1. Troubleshooting on Power Supply Section		
1-1. Supplied to each section		
1-1-1) VU lamps not lighted		<ul style="list-style-type: none"> 1. Defective power cord plug 2. Power cord opens 3. Defective power switch S5 4. Power fuse F01 open 5. Defective voltage selector, PU701 6. Defective power transformer, T701
1-1-2) VU lamps lighted		<ul style="list-style-type: none"> 7. Defective diode, D601~D604 (10D-1) on G-1168 8. Defective transistor, TR601 (2SC1061) on G-1168 9. Defective zener diode, ZD601 (RD-19A) on G-1168
1-2. Excessive hum		<ul style="list-style-type: none"> 10. Defective C604 (100μF 25V), C605 (470μF 25V), C606 (2200μF 35V) on G-1168 11. Defective transistor, TR601 (2SC1061) on G-1168 12. Due to magnetic flux from power transformer
4-1-2. Troubleshooting on Recording System		
2-1. Output 560mV not supplied to LINE OUTPUT		
2-1-1) Output 5mV absent at terminal 05 (21) on G-1127		<ul style="list-style-type: none"> 13. Imperfect contact of LINE IN Jack 14. Imperfect contact of S1-e (S1-f) 15. Defective TR01, TR03 (TR02, TR04) on G-1127 16. Imperfect contact of VR01 (VR02) on G-1159 17. Imperfect contact of MIC Jack 18. Imperfect contact of CENTER MIC Jack 19. Defective TR601 (TR602) on G-1159 20. Imperfect contact of VR601 on G-1159
2-1-4) Output 80mV (chromium tape), 70mV (normal tape) absent at terminal 02 (18) on G-1127		<ul style="list-style-type: none"> 21. Imperfect of S1-c (S1-d) 22. Defective TR05, TR07, TR09 (TR06, TR08, TR10) on G-1127 23. L01, L03, (L02, L04) on G-1127 open 24. Imperfect contact of S1-a, S1-b, S1-g, S1-h on G-1127
2-1-5) Output 560mV absent at LINE OUT		<ul style="list-style-type: none"> 25. Defective VR602a (VR602b) on G-1159 26. Imperfect contact of LINE OUT Jack
2-2. Output 275mV at HEADPHONE Jack		
2-2-1) Output present at LINE OUT		<ul style="list-style-type: none"> 27. Defective TR603 on G-1159 28. Defective TR01, TR03 (TR02, TR04) on G-1159 29. Imperfect contact of headphone jack, J704
2-3. VU meter inoperative		
2-3-1) Output present at LINE OUT		<ul style="list-style-type: none"> 30. Imperfect contact of VR03 (VR04) on G-1127 31. Defective TR13 (TR14) on G-1127 32. Defective D01, D03 (D02, D04) on G-1127 33. Defective VU meter, M701 (M702)

Symptom	Check Point	Cause & What to Do
2-4. Recording system inoperative (Output present at LINE OUT)		34. Defective TR01, TR03 (TR02, TR04) on G-1167
2-5. Defective recording on G-1127		
1) Output 265mV (chromium tape), 240mV (normal tape) absent at terminal 13 (29) on G-1127		35. Defective VR05, VR07 (VR06, VR08) on G-1127 36. Imperfect contact of Tape Selector switch, S2-a~f on G-1160
2) Output 80mV (chromium tape), 70mV (normal tape) absent at terminal 15 (10) on G-1168		37. Defective TR11 (TR12) on G-1127 38. Open L05 (L06) on G-1127
3) Output 25V absent at terminal 13 (12) on G-1168		39. Defective OSC. Block
2-6. Recording system and Oscillator circuit operative		40. Imperfect contact of VR01, VR03 (VR02, VR04) on G-1168 41. Imperfect contact of Tape Selector switch, S2-b, d, e, f on G-1160 42. Defective C01 (C02) on G-1168 43. Defective REC/PB head, YC-303 (In case of no output at both REC and PLAYBACK)
2-7. Imperfect contact of tape and head		44. No output at REC and PLAYBACK
2-8. Record lamp not lighted		
1) Recording system operative		45. Open REC lamp, PL705 46. Imperfect contact of REC lamp and socket
2-9. Excessive distortion in recording		47. Improper setting of Tape Selector switch 48. Improper bias current 49. Defective recording amp 50. Dirty head
2-10. No erasing		51. Loose adjustment of erase head 52. Dirty head 53. Defective head 54. Defective oscillator block
2-11. Peak level lamp not lighted		55. Open peak level lamp 56. Imperfect contact of peak level lamp and socket 57. Defective TR15, TR17 (TR16, TR18) on G-1127 58. Imperfect contact of S1-j on G-1127

4-1-3. Playback System Troubles

3-1. Output 560mV absent at LINE OUT		
1) Output 25mV absent at terminal 09 (25) on G-1127		59. Defective REC/PB head 60. Imperfect contact of S1-a (S1-f) on G-1127 61. Defective TR01, TR03 (TR02, TR04) on G-1127
2) Output 560mV absent at terminal 12 (28) on G-1127		62. Imperfect contact of VR01 (VR02) on G-1127 63. Imperfect contact of S1-g (S1-h) on G-1127 64. Defective T05, T07, TR09 (TR06, TR08, TR10) on G-1127 65. Open L01, L03 (L02, L04) on G-1127

*to page 10

Symptom	Check Point	Cause & What to Do
*from page 9 3) Output 560mV absent at LINE OUT		66. Imperfect contact of S1-k (S1-t) on G-1127 67. Defective OUTPUT LEVEL volume VR602a (VR602b) 68. Defective TR01, TR03 (TR02, TR04) on G-1167
3-2. Output 275mV absent at HEADPHONE Jack		69. See 2-2 in Troubleshooting on Recording System
3-3. No indication on VU meter		70. See 2-3 in Troubleshooting on Recording System

4-1-4. Troubles in Both Recording/Playback Mode

4-1. Less high-frequency signals		71. Dirty head 72. Worn-Out head 73. Loose head position 74. Loose adjustment of head 75. Loose adjustment of equalizer Amp. 76. Defective pressure pad of cassette tape
4-2. Distorted or weak sound		77. Defective Cassette tape 78. Over input level 79. Dirty head 80. Loose adjustment of Head 81. Improper setting of Tape Selector switch (NORMAL or CHROMIUM) in recording 82. Defective capacitor in amplifier
4-3. Excessive noise		83. Excessive tape hiss 84. Defective transistor on amp. section 85. Defective capacitor (resistor) or imperfect contact of volume control 86. Due to external noise 87. Magnetized head

4-1-5. Auto Shut-off Circuit Troubles

5-1. Auto Shut-off Circuit inoperative		88. Defective CdS lamp MKY-5H on G-1180 89. Defective TR02, TR03, TR04 on G-1166 90. Defective relay, RL01 on G-1166 91. Defective plunger solenoid PS701 on G-1166 92. Defective D02, D04, D05 on G-1166 93. Defective C02, C04
--	--	---

4-1-6. Dolby Circuit Troubles

As one Dolby circuit is actuated in both Recording and Playback mode by switching, the same type of trouble may occur in both modes. In case Recording and Playback are normal, but Dolby circuit does not function, it means that TR01, TR03 (TR02, TR04), S1-K (S1-l), S3-a (S5-b) are normal.

6-1. Dolby circuit inoperative (S/N ratio not improved)		94. Defective TR05, TR07 (TR06, TR08) on G-1167
6-2. Incorrect frequency response (Excessive or less high-frequency signals)		95. Defective FET01 (FET02) on G-1167 96. Defective or loose adjustment of VR01 (VR02) and VR03 (VR04) on G-1167 97. Defective D01 (D02), D03, D05 (D04, D06), D07 (D08) on G-1167 98. Defective TR09 (TR10) on G-1167

4-2. TROUBLESHOOTING ON THE MECHANICAL SECTION

Symptom	Check Point	Cause & What to Do
4-2-1. FAST FORWARD Inoperative		
1-1. No tape movement in FAST FORWARD		<ul style="list-style-type: none"> 1. Imperfect contact of drive pulley and right reel hub 2. Slippery drive pulley and right reel hub 3. Slippery drive belt 4. Brake not released 5. Imperfect contact of start switch, S6
4-2-2. REWIND Inoperative		
2-1. No tape movement in REWIND		<ul style="list-style-type: none"> 6. Imperfect contact of drive pulley and left reel hub 7. Slippery drive pulley and left reel hub 8. Brake not released 9. Slippery drive belt 10. Imperfect contact of start switch, S7
4-2-3. PAUSE Inoperative (PAUSE does not function mechanically in REWIND mode)		
3-1. Returning to STOP mode		<ul style="list-style-type: none"> 11. Imperfect contact of PAUSE switch, S9
4-2-4. Incorrect Tape Speed		
		<ul style="list-style-type: none"> 12. Defective motor, MT701 13. Stretched drive belt
4-2-5. Excessive Wow and Flutter		
		<ul style="list-style-type: none"> 14. Defective capstan 15. Improper pressure of pinch roller to capstan 16. Change in shape or quality of pinch roller 17. Stretched drive belt 18. Defective cassette tape
4-2-6. Incorrect Brake		
		<ul style="list-style-type: none"> 19. Oily or slippery reel hub
4-2-7. No Tape Movement		
7-1. Capstan inoperative		<ul style="list-style-type: none"> 20. Motor not rotating 21. Broken drive belt 22. Slippery drive belt and pulley 23. Drive belt slipped off
7-2. Capstan operative		<ul style="list-style-type: none"> 24. Improper pressure of pinch-roller to Capstan 25. Slippery pinch roller 26. Weak reel torque 27. Slippery drive pulley and reel hub 28. Weak motor torque due to drop of Power Line Voltage (AC) 29. Slippery idler

5. PARTS LOCATIONS AND PARTS LISTS

5-1. G-1159 Level Control Circuit Board

(Stock No. 7690160 Complete Circuit Board G-1159)

Conductor Side

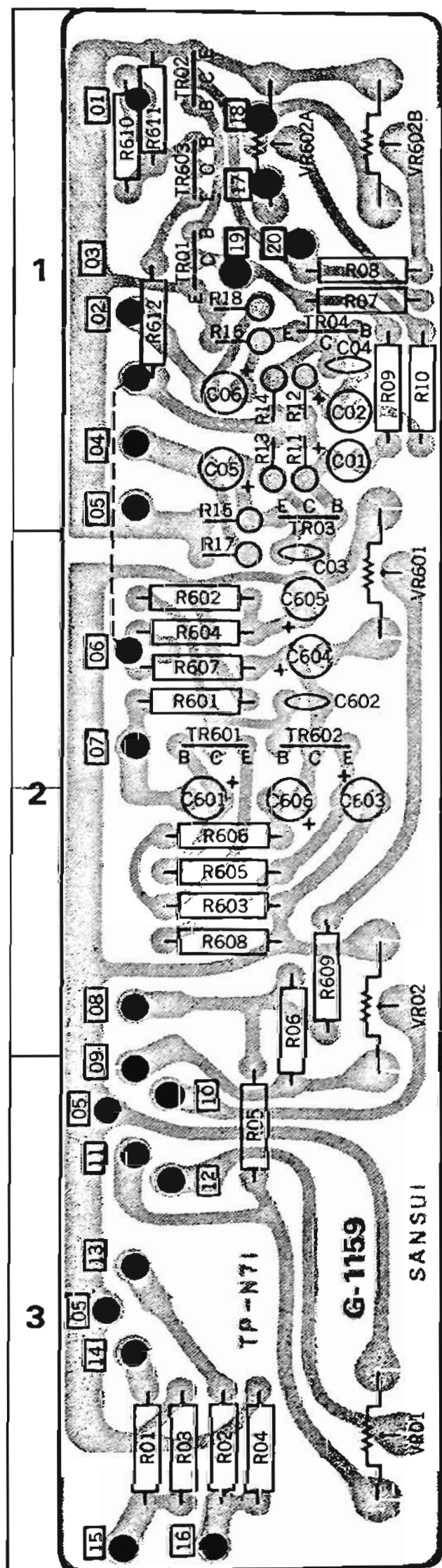

Parts List

Parts No.	Stock No.	Description	Position
TR01	0305731, 2	2SC711 (E, F)	} Transistor
TR02	0305731, 2	2SC711 (E, F)	
TR03	0305732	2SC711 (F)	
TR04	0305732	2SC711 (F)	
TR601	0306091, 2	2SC1312 (G, H)	
TR602	0305731, 2	2SC711 (E, F)	
TR603	0305731, 2	2SC711 (E, F)	
C01	0512100	10 μ F	} 16V E.C.
C02	0512100	10 μ F	
C03	0600221	220pF	} $\pm 10\%$ 50V C.C.
C04	0600221	220pF	
C05	0512330	33 μ F	} 16V E.C.
C06	0512330	33 μ F	
C601	0512100	10 μ F	} $\pm 10\%$ 50V C.C.
C602	0660470	47pF	
C603	0510470	47 μ F	} 6.3V E.C.
C604	0512100	10 μ F	
C605	0512100	10 μ F	} 16V E.C.
C606	0512100	10 μ F	
R01	0107473	47k Ω	} 3
R02	0107473	47k Ω	
R03	0107393	39k Ω	} 3
R04	0107393	39k Ω	
R05	0107104	100k Ω	} $\pm 5\%$ 1/4W C.R.
R06	0107104	100k Ω	
R07	0107102	1k Ω	} 1
R08	0107102	1k Ω	
R09	0107223	22k Ω	} 1
R10	0107223	22k Ω	
R11	0106104	100k Ω	} 1
R12	0106104	100k Ω	
R13	0106100	10 Ω	} $\pm 5\%$ 1/4W C.R. (E.L.R.)
R14	0106100	10 Ω	
R15	0106561	560 Ω	} 1
R16	0106561	560 Ω	
R17	0106101	100 Ω	} 2
R18	0106101	100 Ω	
R601	0107103	10k Ω	} 2
R602	0107104	100k Ω	
R603	0107471	470 Ω	} 2
R604	0107104	100k Ω	
R605	0107104	100k Ω	} $\pm 5\%$ 1/4W C.R.
R606	0107223	22k Ω	
R607	0107472	4.7k Ω	} 2
R608	0107271	270 Ω	
R609	0107102	1k Ω	} 2
R610	0107222	2.2k Ω	
R611	0107474	470k Ω	} 1
R612	0107222	2.2k Ω	
VR01	1000320	50k Ω (B)	} Variable Resistor
VR02	1000320	50k Ω (B)	
VR601	1000310	10k Ω (B)	
VR602	1010910	10k Ω (B) $\times 2$	

5-2. G-1127 REC/PB Amplifier Circuit Board

(Stock No. 7620070 Complete Circuit Board G-1127)

Conductor Side

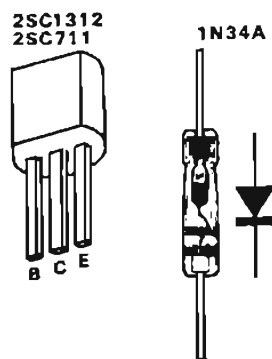
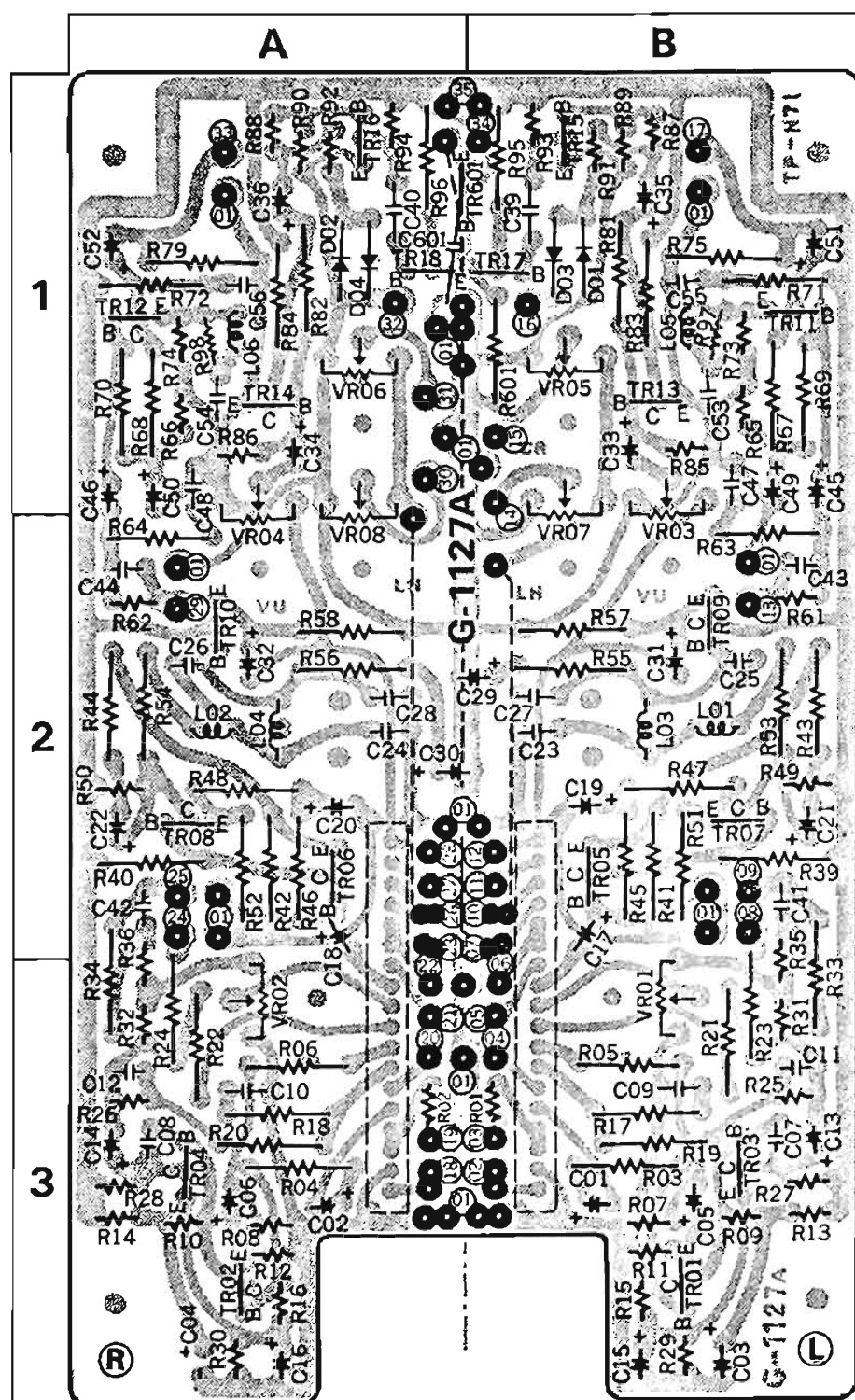

Abbreviations

- | | |
|--|---|
| C.R. : Carbon Resistor | BP.E.C.: Bi-Polar Electrolytic Capacitor |
| S.R. : Solid Resistor | C.C. : Ceramic Capacitor |
| Ce.R. : Cement Resistor | MI.C. : Mica Capacitor |
| M.R. : Metallized Film Resistor | O.C. : Oil Capacitor |
| M.C. : Mylar Capacitor | P.C. : Polystyrene Capacitor |
| E.C. : Electrolytic Capacitor | T.C. : Tantalum Capacitor |

Parts List

Parts No.	Stock No.	Description	Position
TR01	0306091, 2	2SC1312® (G, H)	3 B
TR02	0306091, 2	2SC1312® (G, H)	3 A
TR03	0306091, 2	2SC1312® (G, H)	3 B
TR04	0306091, 2	2SC1312® (G, H)	3 A
TR05	0306091, 2	2SC1312® (G, H)	2 B
TR06	0306091, 2	2SC1312® (G, H)	2 A
TR07	0305731, 2	2SC711 (E, F)	2 B
TR08	0305731, 2	2SC711 (E, F)	2 A
TR09	0305731, 2	2SC711 (E, F)	2 B
TR10	0305731, 2	2SC711 (E, F)	2 A
TR11	0305731, 2	2SC711 (E, F)	1 B
TR12	0305731, 2	2SC711 (E, F)	1 A
TR13	0305731, 2	2SC711 (E, F)	1 B
TR14	0305731, 2	2SC711 (E, F)	1 A
TR15	0305731, 2	2SC711 (E, F)	1 B
TR16	0305731, 2	2SC711 (E, F)	1 A
TR17	0305731, 2	2SC711 (E, F)	1 B
TR18	0305731, 2	2SC711 (E, F)	1 A
TR601	0305731, 2	2SC711 (E, F)	1 B
D01	0310403	1N34A	1 B
D02	0310403	1N34A	1 A
D03	0310403	1N34A	1 B
D04	0310403	1N34A	1 A
L01	4290170	36mH	2 B
L02	4290170	36mH	2 A
L03	4290240	23mH	2 B
L04	4290240	23mH	2 A
L05	4900170	4.7mH	1 B
L06	4900170	4.7mH	1 A
C01	0512100	10µF	3 B
C02	0512100	10µF	3 A
C03	0512100	10µF	3 B
C04	0512100	10µF	3 A
C05	0512100	10µF	3 B
C06	0512100	10µF	3 A
C07	0660101	100pF	3 B
C08	0660101	100pF	3 A
C09	0601476	0.0047µF	3 B
C10	0601476	0.0047µF	3 A
C11	0601107	0.01µF	3 B
C12	0601107	0.01µF	3 A
C13	0512100	10µF	3 B
C14	0512100	10µF	3 A
C15	0510470	47µF	3 B
C16	0510470	47µF	3 A
C17	0512100	10µF	3 B
C18	0512100	10µF	3 A
C19	0510470	47µF	2 B
C20	0510470	47µF	2 A
C21	0512100	10µF	2 B
C22	0512100	10µF	2 A
C23	0600396	0.0039µF	2 B
C24	0600396	0.0039µF	2 A
C25	0600306	0.003µF	2 B
C26	0600306	0.003µF	2 A
C27	0600226	0.0022µE	2 B
C28	0600226	0.0022µE	2 A
C29	0512330	33µF	2 A B
C30	0512330	33µF	2 A
C31	0512100	10µF	2 B



Parts No.	Stock No.	Description	Position	Parts No.	Stock No.	Description	Position
C32	0512100	10 μ F	2 A	R43	0107823	82k Ω	2 B
C33	0512100	10 μ F	1 B	R44	0107823	82k Ω	2 A
C34	0512100	10 μ F	1 A	R45	0107104	100k Ω	2 B
C35	0515109	1 μ F	1 B	R46	0107104	100k Ω	2 A
C36	0515109	1 μ F	1 A	R47	0107102	1k Ω	2 B
C37	0601157	0.015 μ F		R48	0107102	1k Ω	2 A
C38	0601157	0.015 μ F		R49	0106472	4.7k Ω	2 B
C39	0601108	0.1 μ F	1 B	R50	0106472	4.7k Ω	2 A
C40	0601108	0.1 μ F	1 A	R51	0107471	470 Ω	2 B
C41	0601396	0.0039 μ F	2 B	R52	0107471	470 Ω	2 A
C42	0601396	0.0039 μ F	2 A	R53	0107222	2.2k Ω	2 B
C43	0600106	0.001 μ F	2 B	R54	0107222	2.2k Ω	2 A
C44	0600106	0.001 μ F	2 A	R55	0107562	5.6k Ω	2 B
C45	0512100	10 μ F	1, 2 B	R56	0107562	5.6k Ω	2 A
C46	0512100	10 μ F	1, 2 A	R57	0107472	4.7k Ω	2 B
C47	0601477	0.047 μ F	1 B	R58	0107472	4.7k Ω	2 A
C48	0601477	0.047 μ F	1, 2 A	R61	0106393	39k Ω	2 B
C49	0512100	10 μ F	1, 2 B	R62	0106393	39k Ω	2 A
C50	0512100	10 μ F	1, 2 A	R63	0107223	22k Ω	2 B
C51	0512100	10 μ F	1 B	R64	0107223	22k Ω	1 A
C52	0512100	10 μ F	1 A	R65	0106683	68k Ω	1 B
C53	0601227	0.022 μ F	1 B	R66	0106683	68k Ω	1 A
C54	0601227	0.022 μ F	1 A	R67	0107104	100k Ω	1 B
R01	0106101	100 Ω	3 B	R68	0107104	100k Ω	1 A
R02	0106101	100 Ω	3 A	R69	0107224	220k Ω	1 B
R03	0107102	1k Ω	3 B	R70	0107224	220k Ω	1 A
R04	0107102	1k Ω	3 A	R71	0107822	8.2k Ω	1 B
R05	0107562	5.6k Ω	3 B	R72	0107822	8.2k Ω	1 A
R06	0107562	5.6k Ω	3 A	R73	0106821	820 Ω	1 B
R07	0106271	270 Ω	3 B	R74	0106821	820 Ω	1 A
R08	0106271	270 Ω	3 A	R75	0107723	22k Ω	1 B
R09	0106104	100k Ω	3 B	R76	0107723	22k Ω	1 A
R10	0106104	100k Ω	3 A	R81	0107104	100k Ω	1 B
R11	0106103	10k Ω	3 B	R82	0107104	100k Ω	1 A
R12	0106103	10k Ω	3 A	R83	0107332	3.3k Ω	1 B
R13	0106104	100k Ω	3 B	R84	0107332	3.3k Ω	1 A
R14	0106104	100k Ω	3 A	R85	0106223	22k Ω	1 B
R15	0106473	47k Ω	3 B	R86	0106223	22k Ω	1 A
R16	0106473	47k Ω	3 A	R87	0106103	10k Ω	1 B
R17	0107152	1.5k Ω	3 B	R88	0106103	10k Ω	1 A
R18	0107152	1.5k Ω	3 A	R89	0106222	2.2k Ω	1 B
R19	0107392	3.9k Ω	3 B	R90	0106222	2.2k Ω	1 A
R20	0107392	3.9k Ω	3 A	R91	0106152	1.5k Ω	1 B
R21	0107222	2.2k Ω	3 B	R92	0106152	1.5k Ω	1 A
R22	0107222	2.2k Ω	3 A	R93	0106104	100k Ω	1 B
R23	0107473	47k Ω	3 B	R94	0106104	100k Ω	1 A
R24	0107473	47k Ω	3 A	R95	0107332	3.3k Ω	1 B
R25	0106154	150k Ω	3 B	R96	0107332	3.3k Ω	1 A
R26	0106154	150k Ω	3 A	R97	0106182	1.8k Ω	1 B
R27	0106472	4.7k Ω	3 B	R98	0106182	1.8k Ω	1 A
R28	0106472	4.7k Ω	3 A	R99	0107332	3.3k Ω	1 B
R29	0106681	680 Ω	3 B	R100	0107332	3.3k Ω	1 A
R30	0106681	680 Ω	3 A	R601	0107471	470 Ω	1 B
R31	0106103	10k Ω	3 B	VR01	1030770	50k Ω (B)	2 B
R32	0106103	10k Ω	3 A	VR02	1030770	50k Ω (B)	3 A
R33	0107474	470k Ω	3 B	VR03	1030760	20k Ω (B)	2 B
R34	0107474	470k Ω	3 A	VR04	1030760	20k Ω (B)	2 A
R35	0106103	10k Ω	2, 3 B	VR05	1030760	20k Ω (B)	1 B
R36	0106103	10k Ω	2, 3 A	VR06	1030760	20k Ω (B)	1 A
R39	0107104	100k Ω	2 B	VR07	1030760	20k Ω (B)	2 B
R40	0107104	100k Ω	2 B	VR08	1030760	20k Ω (B)	2 A
R41	0107391	390 Ω	2 B	S1	1110230	Slide Switch	
R42	0107391	390 Ω	2 B				

5-3. G-1167 Dolby Circuit Board

(Stock No. 7660030 Complete Circuit Board G-1167)

Conductor Side

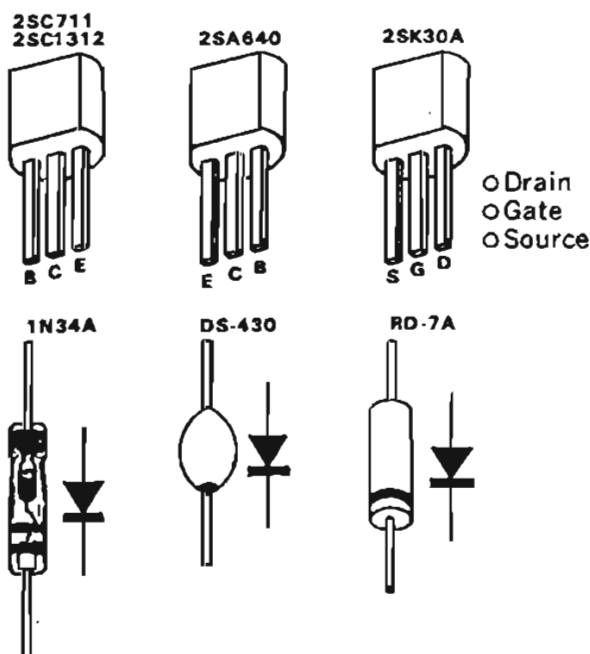
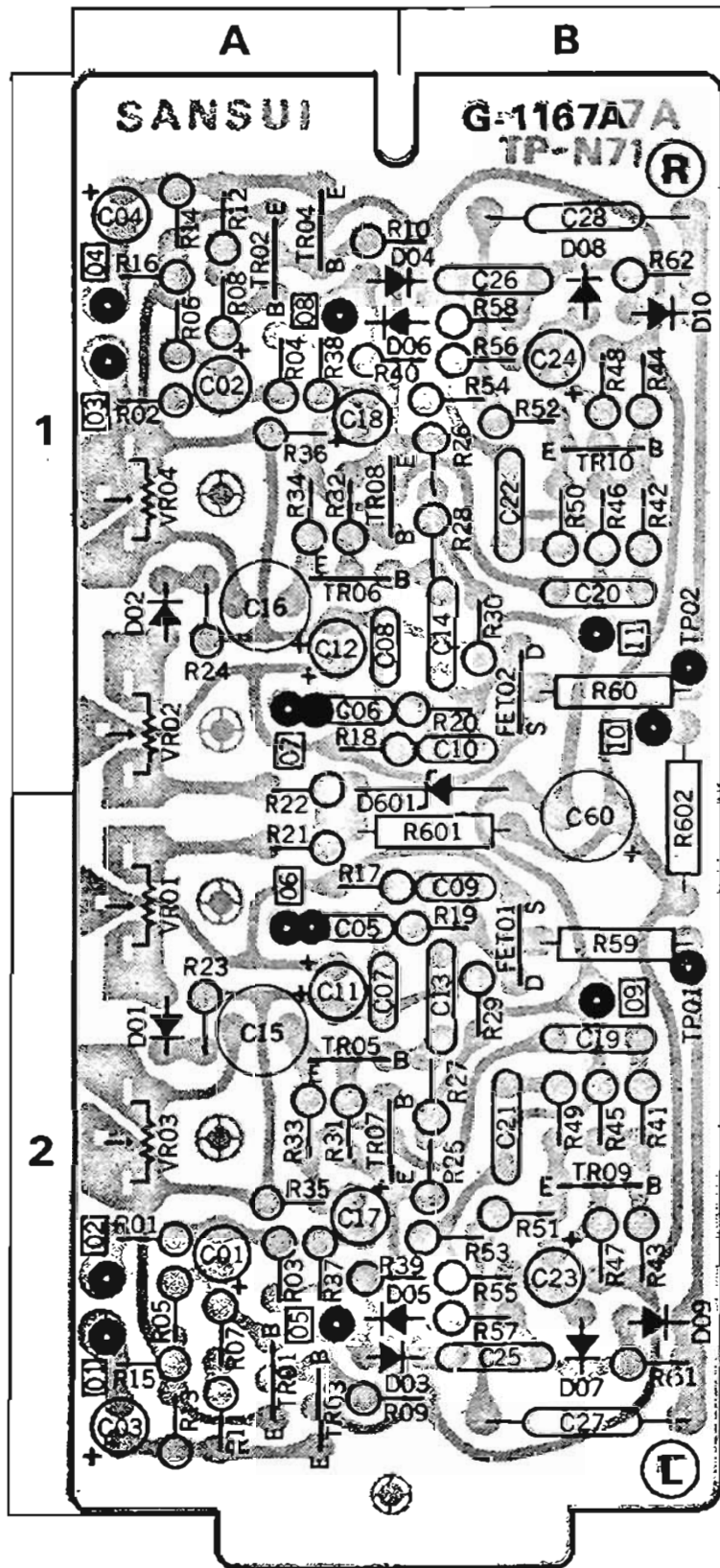

Parts List

Parts No.	Stock No.	Description	Position
TR01	0306091, 2	2SC1312 (G, H)	2A
TR02	0306091, 2	2SC1312 (G, H)	1A
TR03	0306091, 2	2SC1312 (G, H)	2A
TR04	0306091, 2	2SC1312 (G, H)	1A
TR05	0305731, 2	2SC711 (E, F)	2A
TR06	0305731, 2	2SC711 (E, F)	1A
TR07	0300300, 1	2SA640 (M, N)	2A
TR08	0300300, 1	2SA640 (M, N)	1A
TR09	0305731, 2	2SC711 (E, F)	2B
TR10	0305731, 2	2SC711 (E, F)	1B
FET01	0370104	2SK30A (D)	2B
FET02	0370104	2SK30A (D)	1B
D01	0310403	IN34A	2A
D02	0310403	IN34A	1A
D03	0340090	DS-430	2A, B
D04	0340090	DS-430	2A, B
D05	0340090	DS-430	2A, B
D06	0340090	DS-430	1A, B
D07	0310403	IN34A	2B
D08	0310403	IN34A	1B
D09	0340090	DS-430	2B
D10	0340090	DS-430	1B
ZD601	0315170	RD-7A Zener Diode	2A, B
C01	0512100	10 μ F	2A
C02	0512100	10 μ F	1A
C03	0512100	10 μ F	16V E.C. 2A
C04	0512100	10 μ F	1A
C05	0600566	0.0056 μ F	2A
C06	0600566	0.0056 μ F	1A
C07	0600277	0.027 μ F \pm 5%	50V M.C. 2A
C08	0600277	0.027 μ F	2B
C09	0600476	0.0047 μ F	1B
C10	0600476	0.0047 μ F	2A
C11	0512100	10 μ F	16V E.C. 1A
C12	0512100	10 μ F	2B
C13	0601108	0.1 μ F \pm 10%	50V M.C. 1B
C14	0601108	0.1 μ F	2A
C15	0510470	47 μ F	6.3V E.C. 1A
C16	0510470	47 μ F	2A
C17	0512100	10 μ F	16V E.C. 1A
C18	0512100	10 μ F	2B
C19	0601108	0.1 μ F	1B
C20	0601108	0.1 μ F \pm 10%	50V M.C. 2B
C21	0600108	0.1 μ F	1B
C22	0600108	0.1 μ F	2B
C23	0512100	10 μ F	16V E.C. 1B
C24	0512100	10 μ F	2B
C25	0601108	0.1 μ F \pm 10%	50V M.C. 1B
C26	0601108	0.1 μ F	2B
C27	0601108	0.1 μ F	1B
C28	0601108	0.1 μ F	2A, B
C601	0512101	100 μ F	16V E.C. 2A, B
R01	0106154	150k Ω	2A
R02	0106154	150k Ω	1A
R03	0106184	180k Ω	2A
R04	0106184	180k Ω	1A
R05	0106273	27k Ω \pm 5%	1/4W C.R. (E.L.R.) 2A
R06	0106273	27k Ω	1A
R07	0106822	8.2k Ω	2A
R08	0106822	8.2k Ω	1A
R09	0106223	22k Ω	2A, B

5-4. G-1166 Auto Shut-off Circuit Board

(Stock No. 7690150 Complete Circuit Board G-1166)

Conductor Side

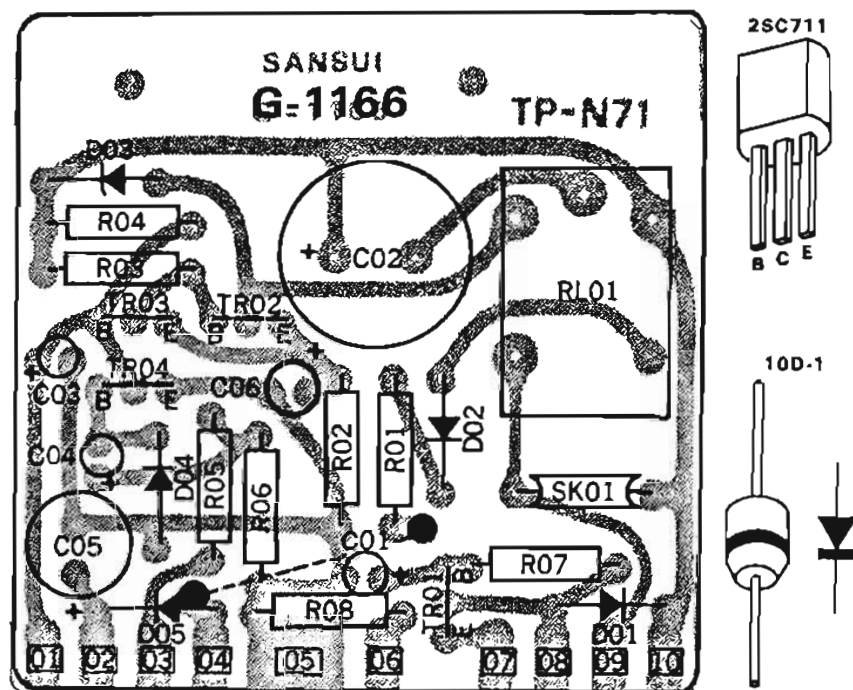

Parts No.	Stock No.	Description	Position
R10	0106223	22k Ω	1 B
R11	0106154	150k Ω	2 A
R12	0106154	150k Ω	1 A
R13	0106272	2.7k Ω	2 A
R14	0106272	2.7k Ω	1 A
R15	0106333	33k Ω	2 A
R16	0106333	33k Ω	1 A
R17	0106332	3.3k Ω	2 A
R18	0106332	3.3k Ω	1 A
R19	0106393	39k Ω	2 B
R20	0106393	39k Ω	1 B
R21	0106562	5.6k Ω	2 A
R22	0106562	5.6k Ω	2 A
R23	0106152	1.5k Ω	2 A
R24	0106152	1.5k Ω	1 A
R25	0106123	12k Ω	2 B
R26	0106123	12k Ω	1 B
R27	0106684	680k Ω	2 B
R28	0106684	680k Ω	1 B
R29	0106682	6.8k Ω	2 B
R30	0106682	6.8k Ω	1 B
R31	0106153	15k Ω	2 A
R32	0106153	15k Ω	1 A
R33	0106822	8.2k Ω	2 A
R34	0106822	8.2k Ω	1 A
R35	0106103	10k Ω	2 A
R36	0106103	10k Ω	1 A
R37	0106822	8.2k Ω	2 A
R38	0106822	8.2k Ω	1 A
R39	0106333	33k Ω	2 A, B
R40	0106333	33k Ω	1 A, B
R41	0106822	8.2k Ω	2 B
R42	0106822	8.2k Ω	1 B
R43	0106124	120k Ω	2 B
R44	0106124	120k Ω	1 B
R45	0106473	47k Ω	2 B
R46	0106473	47k Ω	1 B
R47	0106272	2.7k Ω	2 B
R48	0106272	2.7k Ω	1 B
R49	0106470	47 Ω	2 B
R50	0106470	47 Ω	1 B
R51	0106102	1k Ω	2 B
R52	0106102	1k Ω	1 B
R53	0106330	33 Ω	2 B
R54	0106330	33 Ω	1 B
R55	0106153	15k Ω	2 B
R56	0106153	15k Ω	1 B
R57	0106274	270k Ω	2 B
R58	0106274	270k Ω	1 B
R59	0107224	220k Ω	2 B
R60	0107224	220k Ω	1 B
R61	0106274	270k Ω	2 B
R62	0106274	270k Ω	2 B
R601	0107102	1k Ω	2 A, B
R602	0103331	330 Ω	1, 2 B
VR01	1031090, 2	5k Ω (B)	2 A
VR02	1031090, 2	5k Ω (B)	1 A
VR03	1031040	500 Ω (B)	2 A
VR04	1031040	500 Ω (B)	1 A
TP01	2260010	A4-01775-1	2 B
TP02	2260010	A4-01775-1	1 B

Parts List

Parts No.	Stock No.	Description
TR01	0305731, 2	2SC711 (E, F)
TR02	0305731, 2	2SC711 (E, F)
TR03	0305731, 2	2SC711 (E, F)
TR04	0305731, 2	2SC711 (E, F)
} Transistor		
D01	0310340	10D-1
D02	0310340	10D-1
D03	0310340	10D-1
D04	0310340	10D-1
D05	0310340	10D-1
} Diode		
RL01	1150150	LC1-C (DC24V, 1600 Ω) Relay
SK01	0800190	S-1201 120 Ω + 0.1 Spark Killer
C01	0515109	1 μ F
C02	0515471	470 μ F
C03	0510330	33 μ F
C04	0515109	1 μ F
C05	0512101	100 μ F
C06	0510470	47 μ F
50V E.C.		
6.3V E.C.		
50V E.C.		
16V E.C.		
6.3V E.C.		
R01	0107471	470 Ω
R02	0107221	220 Ω
R03	0107182	1.8k Ω
R04	0107274	270k Ω
R05	0107470	47 Ω
R06	0107102	1k Ω
R07	0107473	47k Ω
R08	0107100	10 Ω
} $\pm 5\%$ $\frac{1}{4}$ W C.R.		

5-5. G-1168 Power Supply Circuit Board

(Stock No. 7600060 Complete Circuit Board G-1168)

Conductor Side

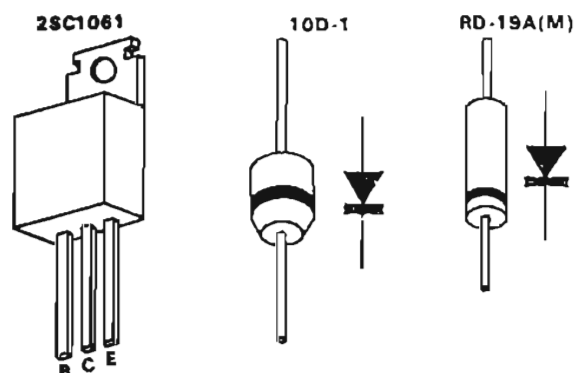
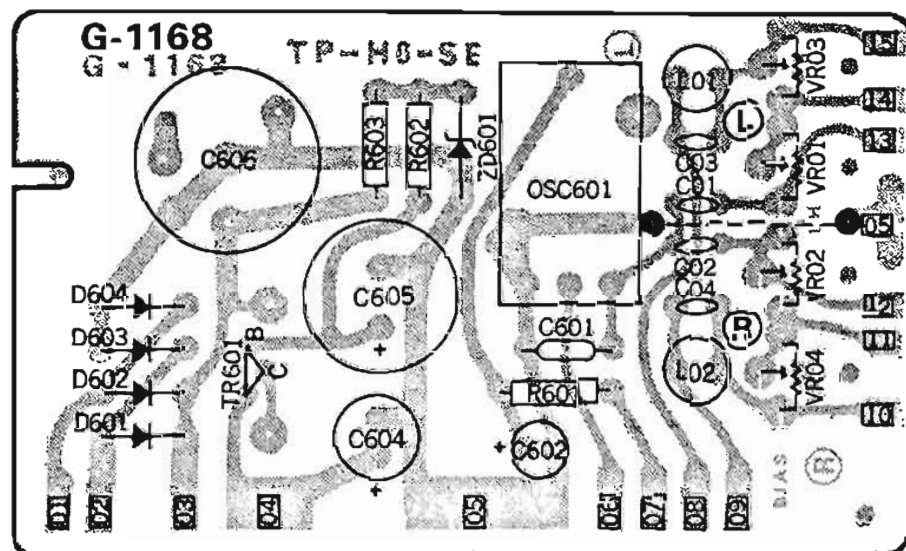

Parts List

Parts No.	StockNo.	Description
TR601	0305771, 2	2SC1061 (B, C) Transistor
D601	0310340	10D-1
D602	0310340	10D-1
D603	0310340	10D-1
D604	0310340	10D-1
ZD601	0315380	RD-19A (M) Zener Diode
OSC601		BO-1 OSC Coil
L01	4900180	LF5-333J 33mH
L02	4900180	LF5-333J 33mH
		} Micro-inductor
C01	0660560	56pF
C02	0660560	56pF
C03	0620101	100pF
C04	0620101	100pF
C601	0649001	2200pF
C602	0513100	10μF
C604	0513101	100μF
C605	0513471	470μF
C606	0549005	2200μF
		±10% 50V C.C.
		±5% 50V P.C.
		±5% 300V Mi.C.
		25V E.C.
		25V E.C.
		25V E.C.
		35V E.C.
R601	0107390	39Ω
R602	0107390	39Ω
R603	0107152	1.5kΩ
		±5% 1/4W C.R.
VR01	1030800	500kΩ (B)
VR02	1030800	500kΩ (B)
VR03	1030790	200kΩ (B)
VR04	1030790	200kΩ (B)
		} Semi-Variable Resistor

5-6. G-1160 Switch Circuit Board

(Stock No. 7690140 Complete Circuit Board G-1160)

Parts List

Parts No.	Stock No.	Description
S2	1130740	SUB 32059 Push Switch

5-7. G-1180 CdS Circuit Board

(Stock No. 7690130 Complete Circuit Board G-1180)

Parts List

Parts No.	Stock No.	Description
CdS10	0920050	MKY-5C38 CdS

5-8. G-1185 Fuse Circuit Board

Parts List

Parts No.	Stock No.	Description
F01	0432810	0.5A Power Fuse (220~140V)
	0432830	1A Power Fuse (100~117V)
F02	0432830	1A
F03	0432800	0.3A
F04	0432890	4A
		} Fuse
	2310150	Fuse Holder

Abbreviations

C.R. : Carbon Resistor	BP.E.C.: Bi-Polar Electrolytic Capacitor
S.R. : Solid Resistor	C.C. : Ceramic Capacitor
Ca.R. : Cement Resistor	M.I.C. : Mica Capacitor
M.R. : Metallized Film Resistor	O.C. : Oil Capacitor
M.C. : Mylar Capacitor	P.C. : Polystyrene Capacitor
E.C. : Electrolytic Capacitor	T.C. : Tantalum Capacitor

5-9. Other Parts

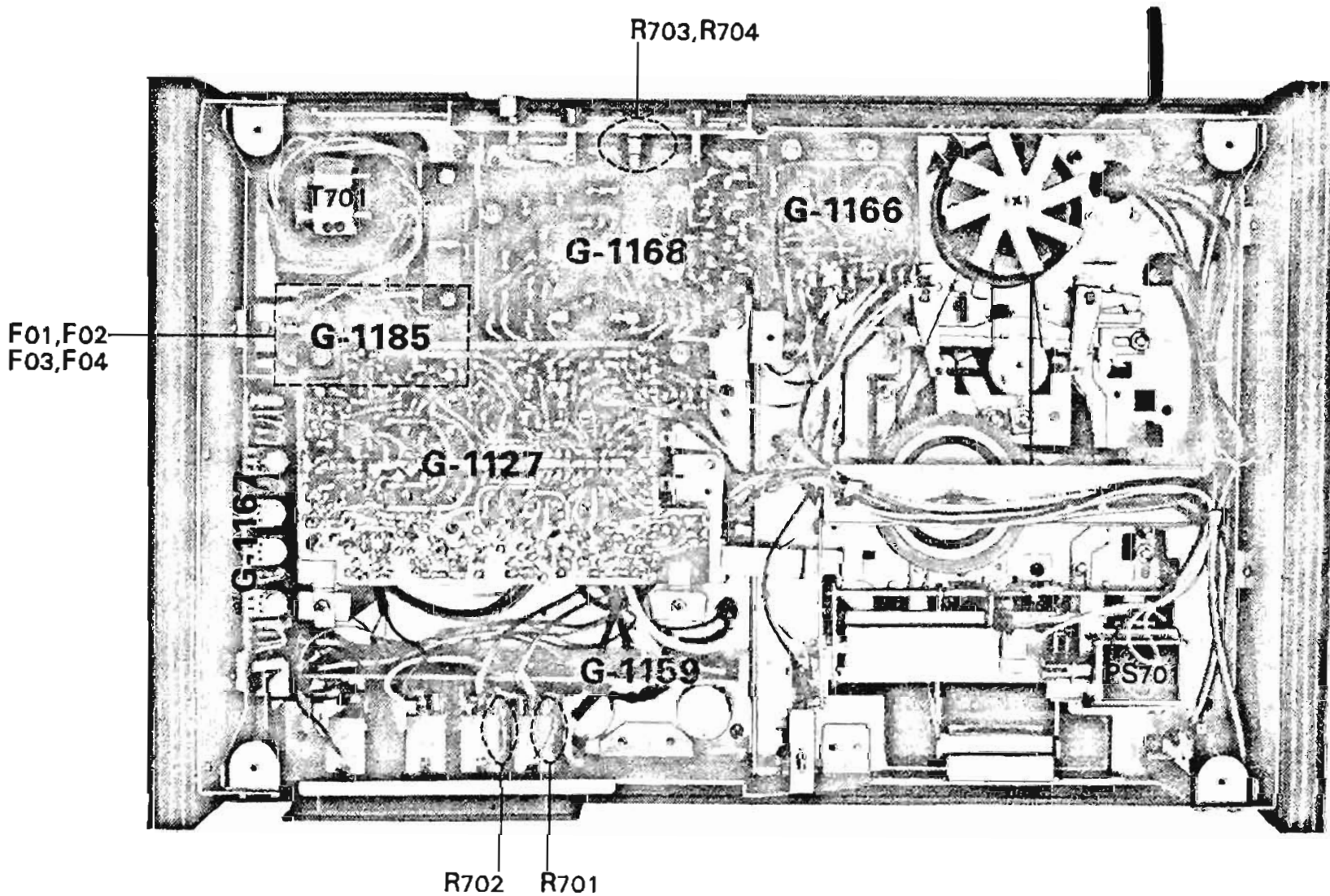
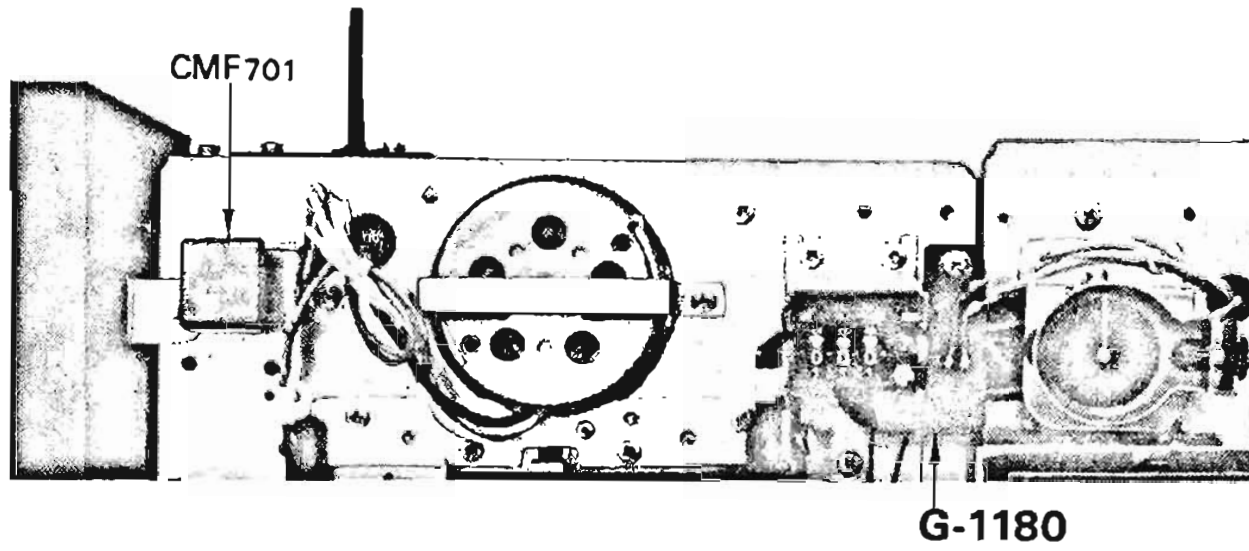

Parts List

Parts No.	Stock No.	Description
CMF701	0609001	1 μ F 230V M.C.
R701	0107103	10k Ω
R702	0107103	10k Ω
R703	0107104	100k Ω
R704	0107104	100k Ω
		} $\pm 5\%$ $\frac{1}{4}$ W C.R.
F01	{ 0430830	0.5A Power Fuse (220~240V)
	{ 0430810	1A Power Fuse (100~117V)
F02	0432830	1A Wired-in Fuse
F03	0432800	0.3A Wired-in Fuse
F04	0432890	4A Wired-in Fuse

Abbreviations

C.R.	: Carbon Resistor	BP.E.C.:	Bi-Polar Electrolytic Capacitor
S.R.	: Solid Resistor	C.C.	: Ceramic Capacitor
Ce.R.	: Cement Resistor	Mi.C.	: Mica Capacitor
M.R.	: Metallized Film Resistor	O.C.	: Oil Capacitor
M.C.	: Mylar Capacitor	P.C.	: Polystyrene Capacitor
E.C.	: Electrolytic Capacitor	T.C.	: Tantalum Capacitor











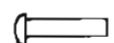
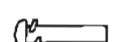
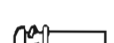

6. DISASSEMBLY WITH EXPLODED AND VIEWS, PARTS LISTS

6-1. Disassembly of the Cabinet, Parts List

Parts No.	Stock No.	Description
1	5101145	B Type Screw, M3×10
2	5121340	S Type Washer, 3φ
3	5120541	P Type Washer, 3φ
4	5101145	B Type Screw, M3×10
5	5121340	S Type Washer, 3φ
6	5120541	P Type Washer, 3φ
7	7010070	Cassette Lid
8	5101143	B Type Screw, M3×6
9	5310171	008 Type Knob, MIC/LINE level volume
10	5310171	008 Type Knob, MIC/LINE level volume
11	5310171	008 Type Knob, CENTER MIC level volume
12	5310171	008 Type Knob, OUTPUT LEVEL volume
13	5101143	B Type Screw, M3×6
14	5120541	P Type Washer, 3φ
15	5101143	B Type Screw, M3×6
16	5120541	P Type Washer, 3φ
17	5101143	B Type Screw, M3×6
18	5120541	P Type Washer, 3φ
19	5101143	B Type Screw, M3×6
20	5120541	P Type Washer, 3φ
21	5101143	B Type Screw, M3×6
22	5120541	P Type Washer, 3φ
23	5109124	B Type Screw, M3×12
24	5510090	Foot
25	5109124	B Type Screw, M3×12
26	5510090	Foot
27	5109124	B Type Screw, M3×12
28	5510090	Foot
29	5109124	B Type Screw, M3×12
30	5510090	Foot
31	5101143	B Type Screw, M3×6
32	5101143	B Type Screw, M3×6
33	5050171	Bottom Lid
34	5050151	Bottom Plate
35	5101843	BSA Type Screw, M3×6
36	5101843	BSA Type Screw, M3×6
37	5101843	BSA Type Screw, M3×6
38	5101843	BSA Type Screw, M3×6
39	5101843	BSA Type Screw, M3×6
40	5101843	BSA Type Screw, M3×6
41	5101943	BSB Type Screw, M3×6
42	5101943	BSB Type Screw, M3×6
43	5101943	BSB Type Screw, M3×6
44	5101943	BSB Type Screw, M3×6
45	5140418	RH Type Screw, M2.7×13
46	5140418	RH Type Screw, M2.7×13
47	5140418	RH Type Screw, M2.7×13
48	5140418	RH Type Screw, M2.7×13
49	5140418	RH Type Screw, M2.7×13
50	5210011	Bracket, side plate
51	5740201	Side Plate
52	5101943	BSB Type Screw, M3×6
53	5101943	BSB Type Screw, M3×6
54	5101943	BSB Type Screw, M3×6
55	5101943	BSB Type Screw, M3×6
56	5140418	RH Type Screw, M2.7×13
57	5140418	RH Type Screw, M2.7×13
58	5140418	RH Type Screw, M2.7×13

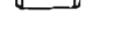
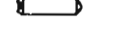
Parts No.	Stock No.	Description
59	5140418	RH Type Screw, M2.7×13
60	5140418	RH Type Screw, M2.7×13
61	5210011	Bracket, side plate
62	5740201	Side Plate
63		Top Cover Ass'y
64	5320340	Knob, POWER switch
65	5320362	Knob, PAUSE switch
66	5320310	Knob, TAPE SELECTOR switch
67	5320310	Knob, DOLBY switch
68		Shield Packing, TAPE SELECTOR and DOLBY switch
69	5101944	BSB Type Screw, M3×8
70	5101944	BSB Type Screw, M3×8
71	5010030	Frame, jack
72	5040360	Masking, jack
73	5040370	Masking, POWER switch
74	5040370	Masking, PAUSE switch

Hardware Nomenclature

Name	Abbreviation	Type
Binding Head Tapping ScrewBT	
Washer Head Tapping ScrewWT	
Pan Head ScrewP	
Binding Head SEMS A ScrewBSA	
Binding Head SEMS B ScrewBSB	
Binding Head SEMS F ScrewBSF	
Binding Head ScrewB	
Flat Countersunk Head ScrewF	
Flat Countersunk Wood ScrewFC	
Round Head Wood ScrewRH	
Hex. Socket Set ScrewSC	
Slot Type Set ScrewSS	
Spring WasherS	
Plain WasherP	
Retaining Ring (E Washer)E	
Toothed Lock Washer (External)	..TLE	

6-1. Disassembly of the Cabinet

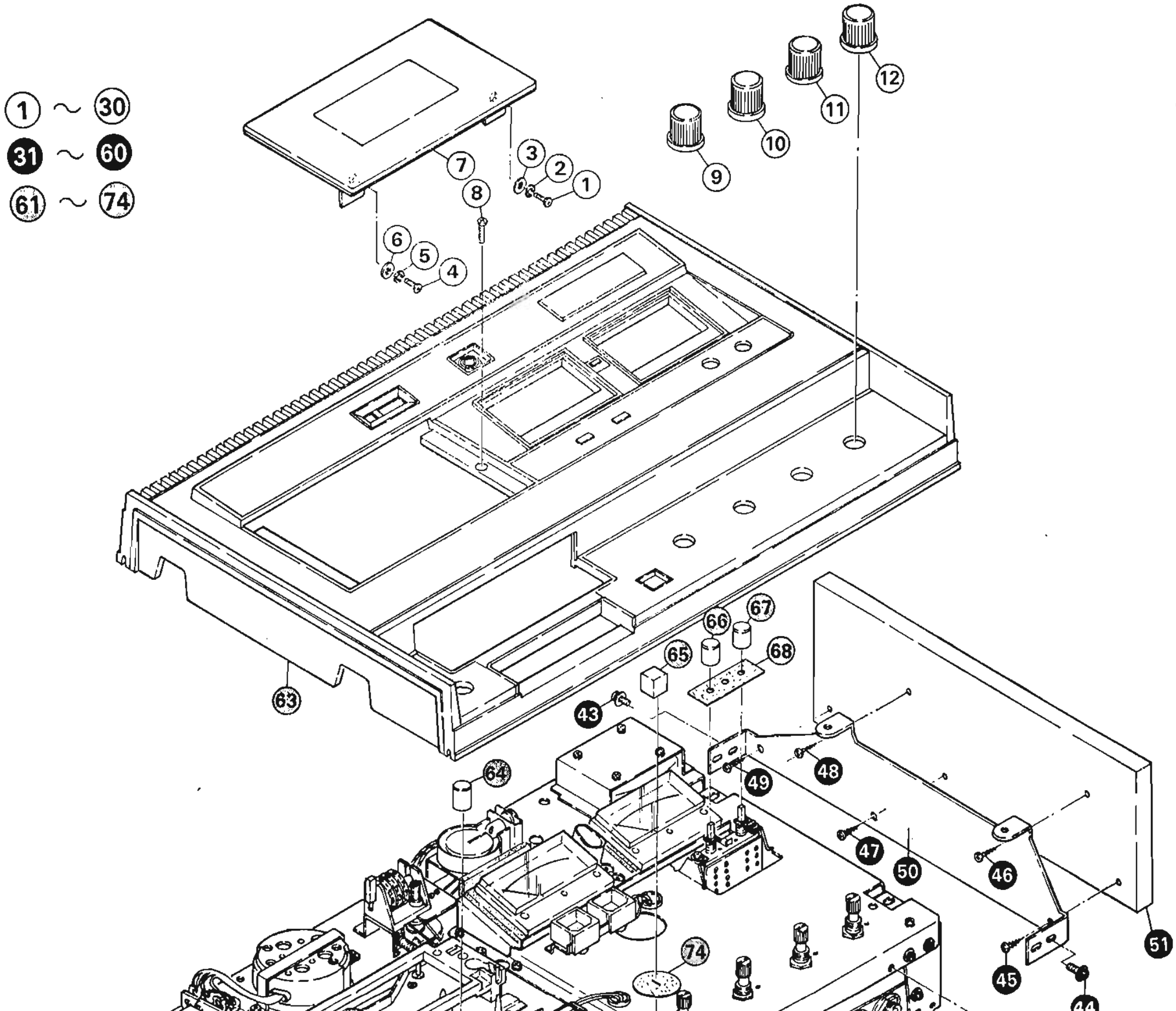

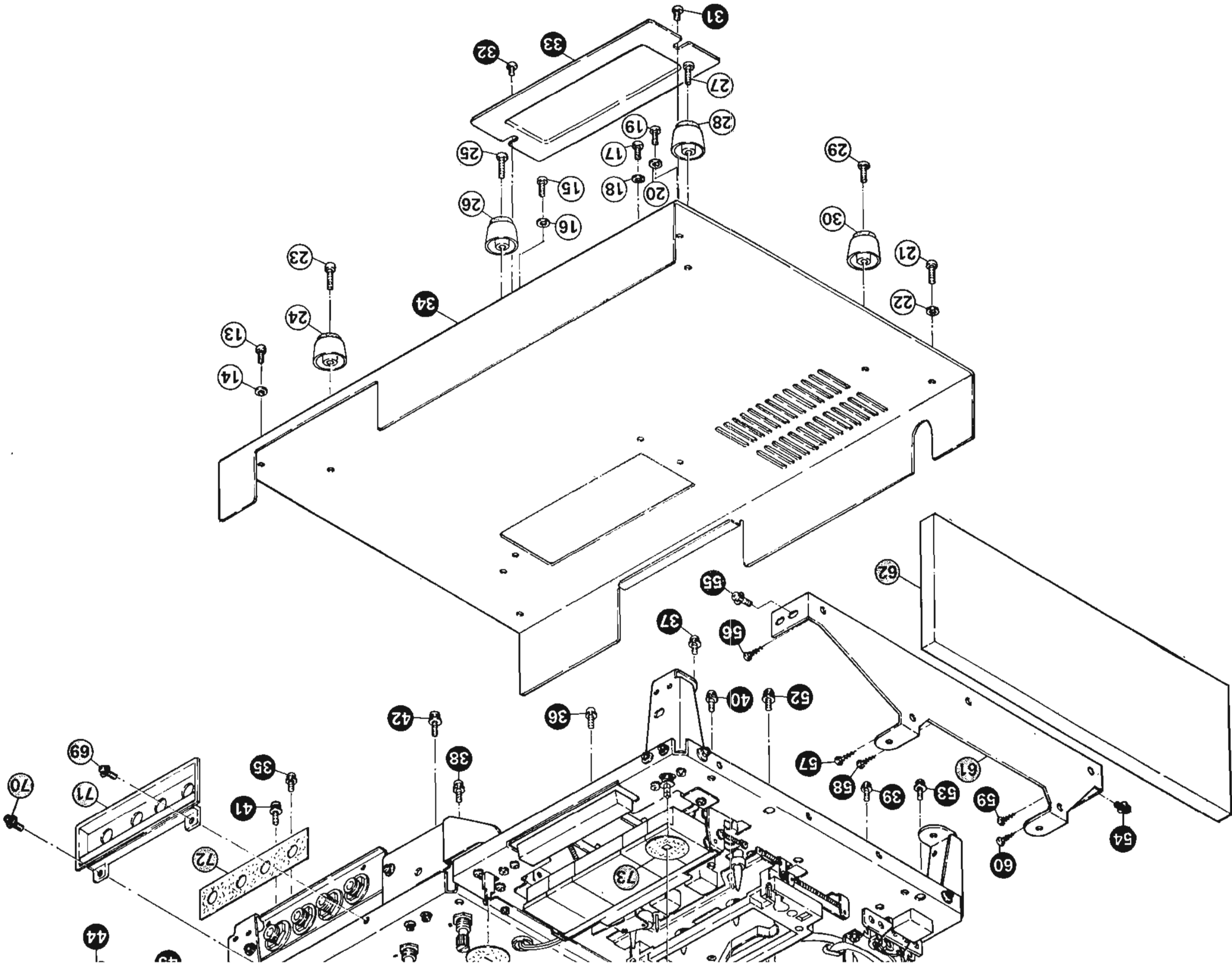

6-2. Disassembly of the Electrical Section

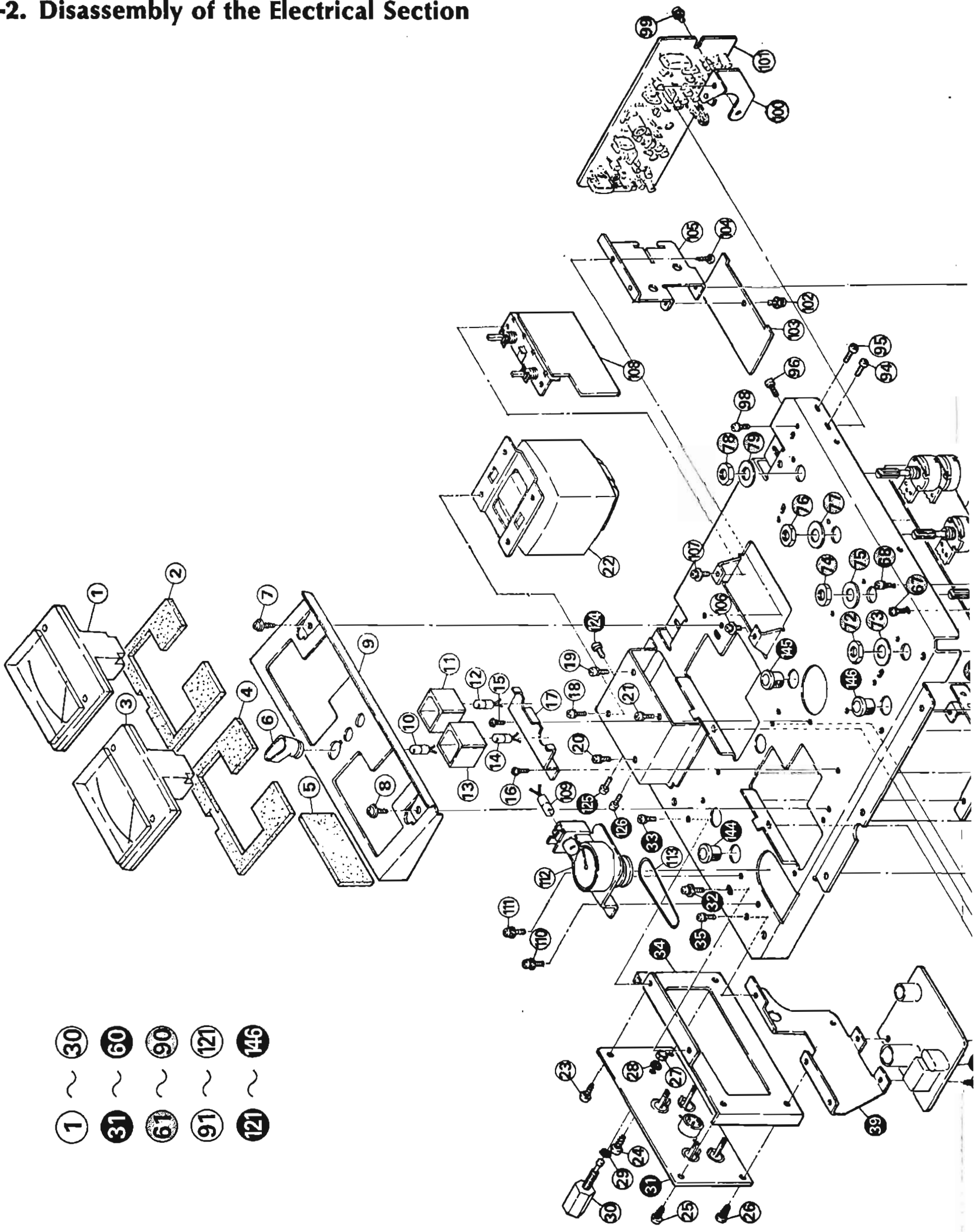

- ① ~ ③①
- ② ~ ③②
- ③ ~ ③③
- ④ ~ ③④
- ⑤ ~ ③⑤
- ⑥ ~ ③⑥
- ⑦ ~ ③⑦
- ⑧ ~ ③⑧
- ⑨ ~ ③⑨
- ⑩ ~ ③⑩
- ⑪ ~ ③⑪
- ⑫ ~ ③⑫
- ⑬ ~ ③⑬
- ⑭ ~ ③⑭
- ⑮ ~ ③⑮
- ⑯ ~ ③⑯
- ⑰ ~ ③⑰
- ⑱ ~ ③⑱
- ⑲ ~ ③⑲
- ⑳ ~ ③⑳
- ㉑ ~ ③㉑
- ㉒ ~ ③㉒
- ㉓ ~ ③㉓
- ㉔ ~ ③㉔
- ㉕ ~ ③㉕
- ㉖ ~ ③㉖
- ㉗ ~ ③㉗
- ㉘ ~ ③㉘
- ㉙ ~ ③㉙
- ㉚ ~ ③㉚
- ㉛ ~ ③㉛
- ㉜ ~ ③㉜
- ㉝ ~ ③㉝
- ㉞ ~ ③㉞
- ㉟ ~ ③㉟
- ㊱ ~ ③㊱
- ㊲ ~ ③㊲
- ㊳ ~ ③㊳
- ㊴ ~ ③㊴
- ㊵ ~ ③㊵
- ㊶ ~ ③㊶
- ㊷ ~ ③㊷
- ㊸ ~ ③㊸
- ㊹ ~ ③㊹
- ㊺ ~ ③㊺
- ㊻ ~ ③㊻
- ㊼ ~ ③㊼
- ㊽ ~ ③㊽
- ㊾ ~ ③㊾
- ㊿ ~ ③㊿
- 1 ~ 1
- 2 ~ 2
- 3 ~ 3
- 4 ~ 4
- 5 ~ 5
- 6 ~ 6
- 7 ~ 7
- 8 ~ 8
- 9 ~ 9
- 10 ~ 10
- 11 ~ 11
- 12 ~ 12
- 13 ~ 13
- 14 ~ 14
- 15 ~ 15
- 16 ~ 16
- 17 ~ 17
- 18 ~ 18
- 19 ~ 19
- 20 ~ 20
- 21 ~ 21
- 22 ~ 22
- 23 ~ 23
- 24 ~ 24
- 25 ~ 25
- 26 ~ 26
- 27 ~ 27
- 28 ~ 28
- 29 ~ 29
- 30 ~ 30
- 31 ~ 31
- 32 ~ 32
- 33 ~ 33
- 34 ~ 34
- 35 ~ 35
- 36 ~ 36
- 37 ~ 37
- 38 ~ 38
- 39 ~ 39
- 40 ~ 40
- 41 ~ 41
- 42 ~ 42
- 43 ~ 43
- 44 ~ 44
- 45 ~ 45
- 46 ~ 46
- 47 ~ 47
- 48 ~ 48
- 49 ~ 49
- 50 ~ 50
- 51 ~ 51
- 52 ~ 52
- 53 ~ 53
- 54 ~ 54
- 55 ~ 55
- 56 ~ 56
- 57 ~ 57
- 58 ~ 58
- 59 ~ 59
- 60 ~ 60
- 61 ~ 61
- 62 ~ 62
- 63 ~ 63
- 64 ~ 64
- 65 ~ 65
- 66 ~ 66
- 67 ~ 67
- 68 ~ 68
- 69 ~ 69
- 70 ~ 70
- 71 ~ 71
- 72 ~ 72
- 73 ~ 73
- 74 ~ 74
- 75 ~ 75
- 76 ~ 76
- 77 ~ 77
- 78 ~ 78
- 79 ~ 79
- 80 ~ 80
- 81 ~ 81
- 82 ~ 82
- 83 ~ 83
- 84 ~ 84
- 85 ~ 85
- 86 ~ 86
- 87 ~ 87
- 88 ~ 88
- 89 ~ 89
- 90 ~ 90
- 91 ~ 91
- 92 ~ 92
- 93 ~ 93
- 94 ~ 94
- 95 ~ 95
- 96 ~ 96
- 97 ~ 97
- 98 ~ 98
- 99 ~ 99
- 100 ~ 100
- 101 ~ 101
- 102 ~ 102
- 103 ~ 103
- 104 ~ 104
- 105 ~ 105
- 106 ~ 106
- 107 ~ 107
- 108 ~ 108
- 109 ~ 109
- 110 ~ 110
- 111 ~ 111
- 112 ~ 112
- 113 ~ 113
- 114 ~ 114
- 115 ~ 115
- 116 ~ 116
- 117 ~ 117
- 118 ~ 118
- 119 ~ 119
- 120 ~ 120
- 121 ~ 121
- 122 ~ 122
- 123 ~ 123
- 124 ~ 124
- 125 ~ 125
- 126 ~ 126
- 127 ~ 127
- 128 ~ 128
- 129 ~ 129
- 130 ~ 130
- 131 ~ 131
- 132 ~ 132
- 133 ~ 133
- 134 ~ 134
- 135 ~ 135
- 136 ~ 136
- 137 ~ 137
- 138 ~ 138
- 139 ~ 139
- 140 ~ 140
- 141 ~ 141
- 142 ~ 142
- 143 ~ 143
- 144 ~ 144
- 145 ~ 145
- 146 ~ 146

6-2. Disassembly of the Electrical Section, Parts List

Parts No.	Stock No.	Description
1	4300490	VU Meter
2	5500471	Meter Cushion
3	4300490	VU Meter
4	5500471	Meter Cushion
5	5040390	Shield Packing A
6	5506522	Power Indicator Rubber
7	5109122	BT Type Screw, M3×8
8	5109122	BT Type Screw, M3×8
9	5260191	Holder, VU meter
10	0400110	Lead Type Lamp (6V 30mA), PEAK Indicator
11	5260210	Lamp Holder
12	0400360	Lead Type Lamp (7V 100mA), DOLBY Indicator
13	5200210	Lamp Holder
14	0400370	Lead Type Lamp (7V 100mA), REC Indicator
15	5109122	BT Type Screw, M3×8
16	5109122	BT Type Screw, M3×8
17	5240860	Bracket, lamp Holder

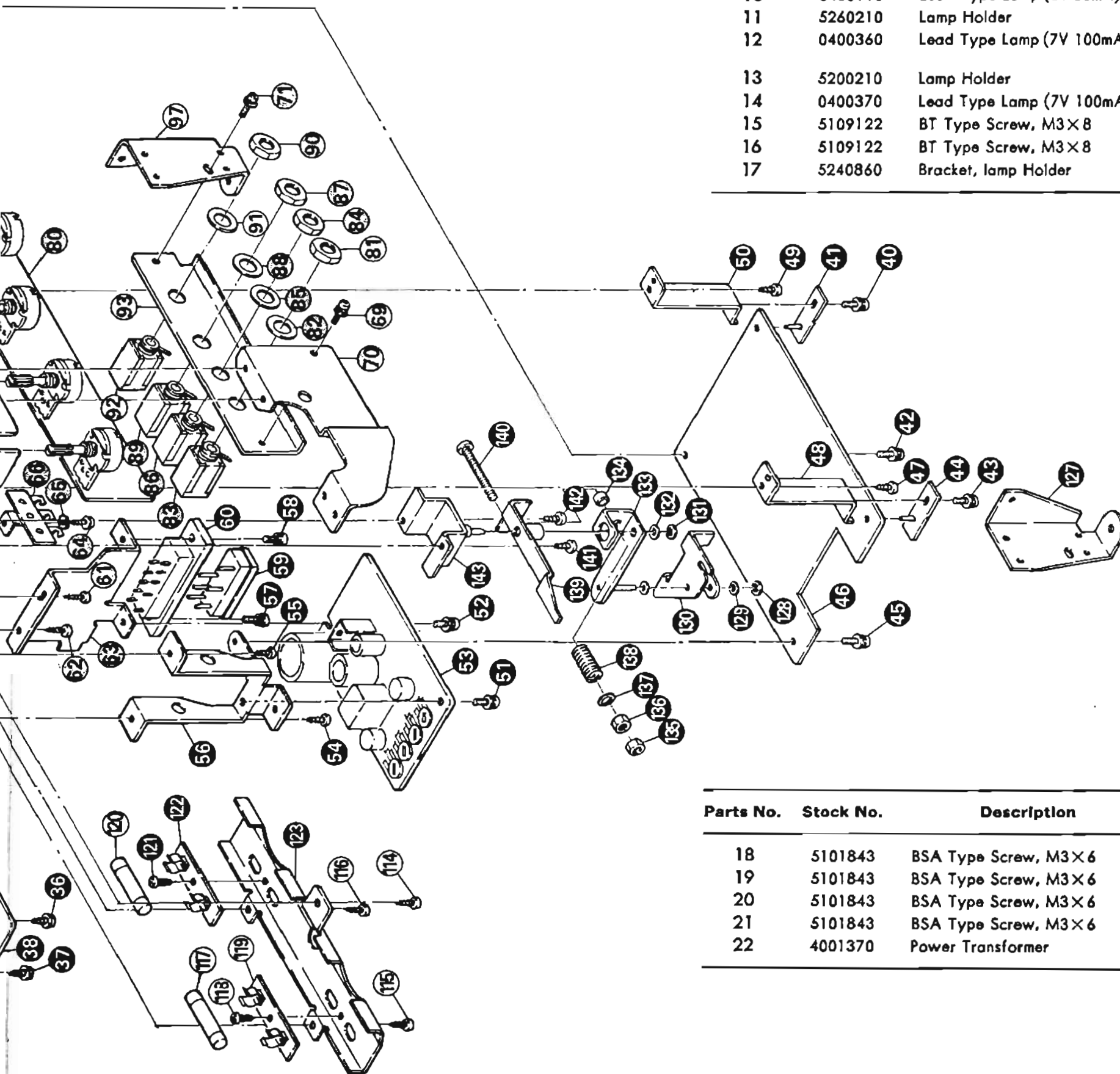

Parts No.	Stock No.	Description
18	5101843	BSA Type Screw, M3×6
19	5101843	BSA Type Screw, M3×6
20	5101843	BSA Type Screw, M3×6
21	5101843	BSA Type Screw, M3×6
22	4001370	Power Transformer

Parts No.	Stock No.	Description
23	5109122	BT Type Screw, M3×8
24	5109122	BT Type Screw, M3×8
25	5109122	BT Type Screw, M3×8
26	5109122	BT Type Screw, M3×8
27	5110261	Hex. Nut, M4
28	5121360	S Type Washer, 4φ
29		P Type Washer (with terminal)
30	2230050	Ground Terminal
31	7710051	Terminal Board Ass'y
32	5101943	BSB Type Screw, M3×6
33	5101843	BSA Type Screw, M3×6
34	5200361	Bracket, terminal board
35	5101843	BSA Type Screw, M3×6
36	5166460	WT Type Screw, M3×8
37	5166460	WT Type Screw, M3×8
38	7690150	Auto Shut-off Circuit Board G-1166
39	5200381	Bracket, rear reinforcement
40	5101943	BSB Type Screw, M3×6
41	6920010	Cord Clip
42	5101943	BSB Type Screw, M3×6
43	5101943	BSB Type Screw, M3×6
44	6920010	Cord Clip
45	5101943	BSB Type Screw, M3×6
46	7620070	REC/PB Amplifier Circuit Board G-1127
47	5109122	BT Type Screw, M3×8
48	5250080	Stand A-1, P.C.B.
49	5109122	BT Type Screw, M3×8
50	5250080	Stand A-1, P.C.B.
51	5101943	BSB Type Screw, M3×6
52	5101943	BSB Type Screw, M3×6
53	7600060	Power Supply Circuit Board G-1168
54	5109122	BT Type Screw, M3×8
55	5109121	BT Type Screw, M3×6
56	5250051	Stand B, P.C.B.
57	5101844	BSA Type Screw, M3×8
58	5101844	BSA Type Screw, M3×8
59	2410090	Voltage Selector, plug
60	2410080	Voltage Selector, socket
61	5109122	BT Type Screw, M3×8
62	5109122	BT Type Screw, M3×8
63	5260202	Holder, voltage selector
64	5166460	WT Type Screw, M3×8
65	5122540	TLE Type Washer, 3φ
66	2110011	ILIA Lug Terminal
67	5101843	BSA Type Screw, M3×6
68	5101843	BSA Type Screw, M3×6
69	5101943	BSB Type Screw, M3×6
70	5200371	Bracket, front reinforcement
71	5101943	BSB Type Screw, M3×6
72	5110780	Hex. Nut, M8
73	5120183	P Type Washer, 8φ
74	5110780	Hex. Nut, M8
75	5120183	P Type Washer, 8φ
76	5110780	Hex. Nut, M8
77	5120183	P Type Washer, 8φ
78	5110780	Hex. Nut, M8
79	5120183	P Type Washer, 8φ
80	7690160	Level Control Circuit Board G-1159
81		Hex. Nut, M12
82		P Type Washer, 12φ
83	2430170	Microphone Jack (Left)
84		Hex. Nut, M12

Parts No.	Stock No.	Description
85		P Type Washer, 12φ
86	2430170	Microphone Jack (Right)
87		Hex. Nut, M12
88		P Type Washer, 12φ
89	2430170	Microphone Jack (Center)
90		Hex. Nut, M12
91		P Type Washer, 12φ
92	2430190	Headphone Jack
93	5240850	Jack Plate
94	5101043	B Type Screw, M3×6
95	5101043	B Type Screw, M3×6
96	5101943	BSB Type Screw, M3×6
97	5250021	Stud A, amplifier chassis
98	5101843	BSA Type Screw, M3×6
99	5101943	BSB Type Screw, M3×6
100	5250071	Stand D, P.C.B.
101	7660030	Dolby Circuit Board G-1167
102	5101943	BSB Type Screw, M3×6
103		Fuse Circuit Board G-1185
104	5109122	BT Type Screw, M3×8
105	5250060	Stand C, P.C.B.
106	5101943	BSB Type Screw, M3×6
107	5101943	BSB Type Screw, M3×6
108	7690140	Switch Circuit Board G-1160
109		Lead Type Lamp (7V 100mA), run-indicator
110	5101943	BSB Type Screw, M3×6
111	5101943	BSB Type Screw, M3×6
112	7110020	Tape-run Indicator Ass'y
113	6030120	Indicator Belt
114	5166460	WT Type Screw, M3×8
115	5166460	WT Type Screw, M3×8
116	5166460	WT Type Screw, M3×8
117	0420040	Fuse Type Lamp (7V, 300mA)
118	5109122	BT Type Screw, M3×8
119	2310150	Fuse Holder
120	0420040	Fuse Type Lamp (7V, 300mA)
121	5109122	BT Type Screw, M3×8
122	2310150	Fuse Holder
123	5240871	Reflection Plate, VU meter
124	5101043	B Type Screw, M3×6
125	5101043	B Type Screw, M3×6
126	5101043	B Type Screw, M3×6
127	5250031	Stud B, amplifier chassis
128	5151002	E Type Washer, 2φ
129	5180340	P Type Washer, 3φ
130	6510121	Bracket, slide switch pusher
131	5151004	E Type Washer, 3φ
132	5180120	P Type Washer, 4φ
133	6500431	Arm, record pusher
134	5230720	Collar, REC limiter
135	5110261	Hex. Nut, M4
136	5110261	Hex. Nut, M4
137	5120161	P Type Washer, 4φ
138	6900650	Spring, record limiter
139	6500420	Arm, record limiter
140	5101070	B Type Screw, M4×30
141	5109122	BT Type Screw, M3×8
142	5109122	BT Type Screw, M3×8
143	5240881	Bracket, record limiter
144	5616110	Snap Bushing
145	5616110	Snap Bushing
146	5616110	Snap Bushing

6-3. Disassembly of the Mechanism (Top View), Parts List

Parts No.	Stock No.	Description	Parts No.	Stock No.	Description
1	5101843	BSA Type Screw, M3×6	63	5121020	S Type Washer, 2φ
2	5101843	BSA Type Screw, M3×6	64	4533430	REC/PB Head
3	5101843	BSA Type Screw, M3×6	65	6900670	Spring (Right), pinch roller
4	5101843	BSA Type Screw, M3×6	66	5103022	B Type Screw, M2.6×4
5	5103323	B Type Screw, M2.6×6	67	5120120	P Type Washer, 2.6φ
6	5121020	S Type Washer, 2.6φ	68	5220360	Hook, pinch roller spring
7	7070050	Spring, cassette holder	69	5151002	E Type Washer, 2φ
8	5110321	Hex. Nut, M2.6	70	7060070	Pinch Roller Ass'y
9	5103323	B Type Screw, M2.6×6	71	5120141	P Type Washer, 3φ
10	5121020	S Type Washer, 2.6φ	72	5101843	BSA Type Screw, M3×6
11	7070050	Spring, cassette holder	73	5120141	P Type Washer, 3φ
12	5110261	Hex. Nut, M4	74	5101843	BSA Type Screw, M3×6
13	5010040	Frame, cassette well	75	5120141	P Type Washer, 3φ
14	6900860	Spring, cassette pusher	76	5240900	Adjusting Plate, head base
15	5151002	E Type Washer, 2φ	77	7050050	Head Base
16	6500660	Cassette Pusher	78	5151001	E Type Washer, 1.5φ
17	5500480	Bushing, well stay	79	5120302	P Type Washer, 2φ
18	6900900	Spring, cassette well	80	6140090	Center Pulley
19	6900881	Spring, well stay	81	5151001	E Type Washer, 1.5φ
20	5151002	E Type Washer, 2φ	82	5120302	P Type Washer, 2φ
21	5500480	Bushing, well stay	83	6140090	Center Pulley
22	5210021	Stay, cassette well	84	5101843	BSA Type Screw, M3×6
23	5101843	BSA Type Screw, M3×6	85	5241010	Holder, pulley
24	5101843	BSA Type Screw, M3×6	86	5101843	BSA Type Screw, M3×6
25	5101843	BSA Type Screw, M3×6	87	7690130	CdS Circuit Board G-1180
26	5101843	BSA Type Screw, M3×6	88	5101843	BSA Type Screw, M3×6
27	5101005	B Type Screw, M2×8	89	5120141	P Type Washer, 3φ
28	5151002	E Type Washer, 2φ	90	5101843	BSA Type Screw, M3×6
29	5151002	E Type Washer, 2φ	91	5120141	P Type Washer, 3φ
30	5240980	Bracket, cassette well	92	5101843	BSA Type Screw, M3×6
31	6210430	Shaft, record censor	93	5101843	BSA Type Screw, M3×6
32	6900871	Spring, record censor	94	5101843	BSA Type Screw, M3×6
33	6900890	Spring, pusher lock bracket	95	6030110	Counter Belt
34	6500680	Record Censor	96	6140100	Counter Pulley
35	6500670	Bracket, pusher lock	97	5430050	Counter
36	5240991	Reflection Plate	98	5241000	Bracket, Counter
37	5240970	Cassette well	99	5101843	BSA Type Screw, M3×6
38	6900820	Spring, brake	100	2110020	2L2A Lug Terminal
39	5101843	BSA Type Screw, M3×6	101	5101043	B Type Screw, M3×6
40	5260240	Retainer (SP-B), steel ball	102	5101043	B Type Screw, M3×6
41	6540030	Steel Ball, 2φ	103	3910070	Cord Clip
42	5151002	E Type Washer, 2φ	104	3800020	Power Cord
43	5151002	E Type Washer, 2φ	105	5220370	Holder Plate, power cord
44	6400091	Brake shoe	106	5101043	B Type Screw, M3×6
45	6900680	Spring, head base	107	5250021	Stud A, mechanism chassis
46	6900680	Spring, head base	108	5101043	B Type Screw, M3×6
47	5101843	BSA Type Screw, M3×6	109	5101043	B Type Screw, M3×6
48	5260231	Retainer (SP-A), steel ball	110	5101043	B Type Screw, M3×6
49	6540030	Steel Ball, 2φ	111	5250031	Stud B, mechanism chassis
50	5101843	BSA Type Screw, M3×6	112	5101843	BSA Type Screw, M3×6
51	5260231	Retainer (SP-A), steel ball	113	5101843	BSA Type Screw, M3×6
52	6540030	Steel Ball, 2φ	114	6200190	Shaft, knob
53	5101206	B Type Screw, M2×10	115	6900700	Spring, knob
54	5101206	B Type Screw, M2×10	116	5320390	EJECT Knob
55	4523030	Erase Head	117	6900700	Spring, knob
56	5230690	Stud, erase head	118	5320390	REWIND Knob
57	5230690	Stud, erase head	119	6900700	Spring, knob
58	5101203	B Type Screw, M2×5	120	5320380	PLAY Knob
59	5120302	P Type Washer, 2φ	121	6900700	Spring, knob
60	5120302	P Type Washer, 2φ	122	5320390	F.F. Knob
61	6900690	Spring, head	123	6900700	Spring, knob
62	5101203	B Type Screw, M2×5	124	5320400	REC Knob

6-3. Disassembly of the Mechanism (Top View)

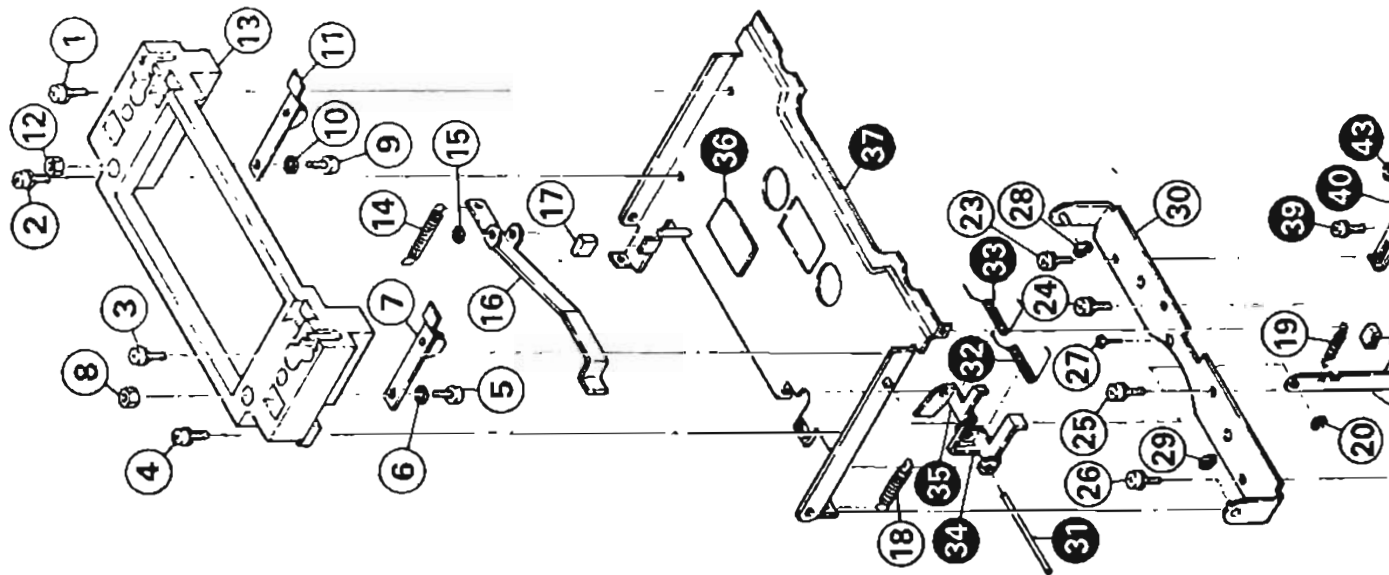
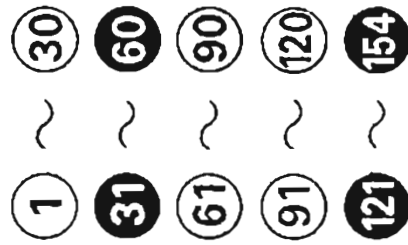
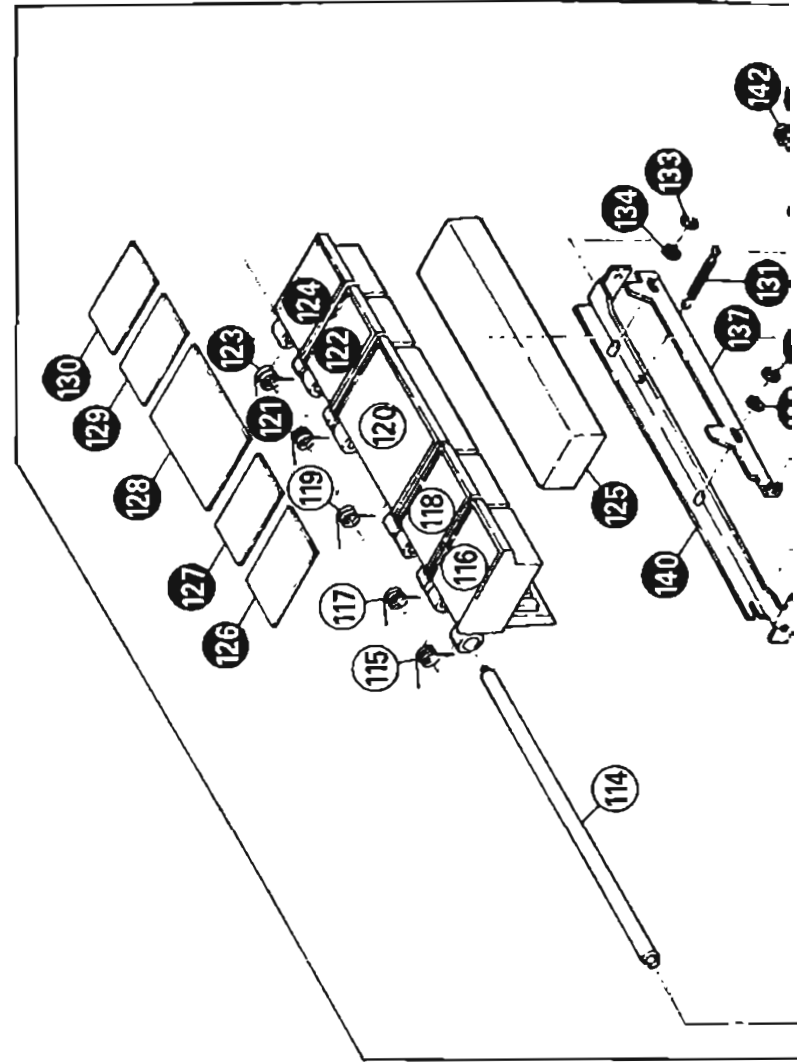

Parts No.	Stock No.	Description
125	5320370	STOP Knob
126	5360301	Name Plate, EJECT knob
127	5360301	Name Plate, REWIND knob
128	5360291	Name Plate, PLAY knob
129	5360301	Name Plate, F.F. knob
130	5360312	Name Plate, REC knob
131	6900710	Spring, stop
132	6900730	Spring, lock plate
133	5151002	E Type Washer, 2φ
134	5120302	P Type Washer, 2φ

Parts No.	Stock No.	Description
135	5151002	E Type Washer, 2φ
136	5120302	P Type Washer, 2φ
137	6510130	Lock Plate, knob
138	5101843	BSA Type Screw, M3×6
139	5101843	BSA Type Screw, M3×6
140	6900730	Spring, lock plate
141	5101843	BSA Type Screw, M3×6
142	5101843	BSA Type Screw, M3×6
143	5240910	Frame, knob
144	5151002	E Type Washer, 2φ

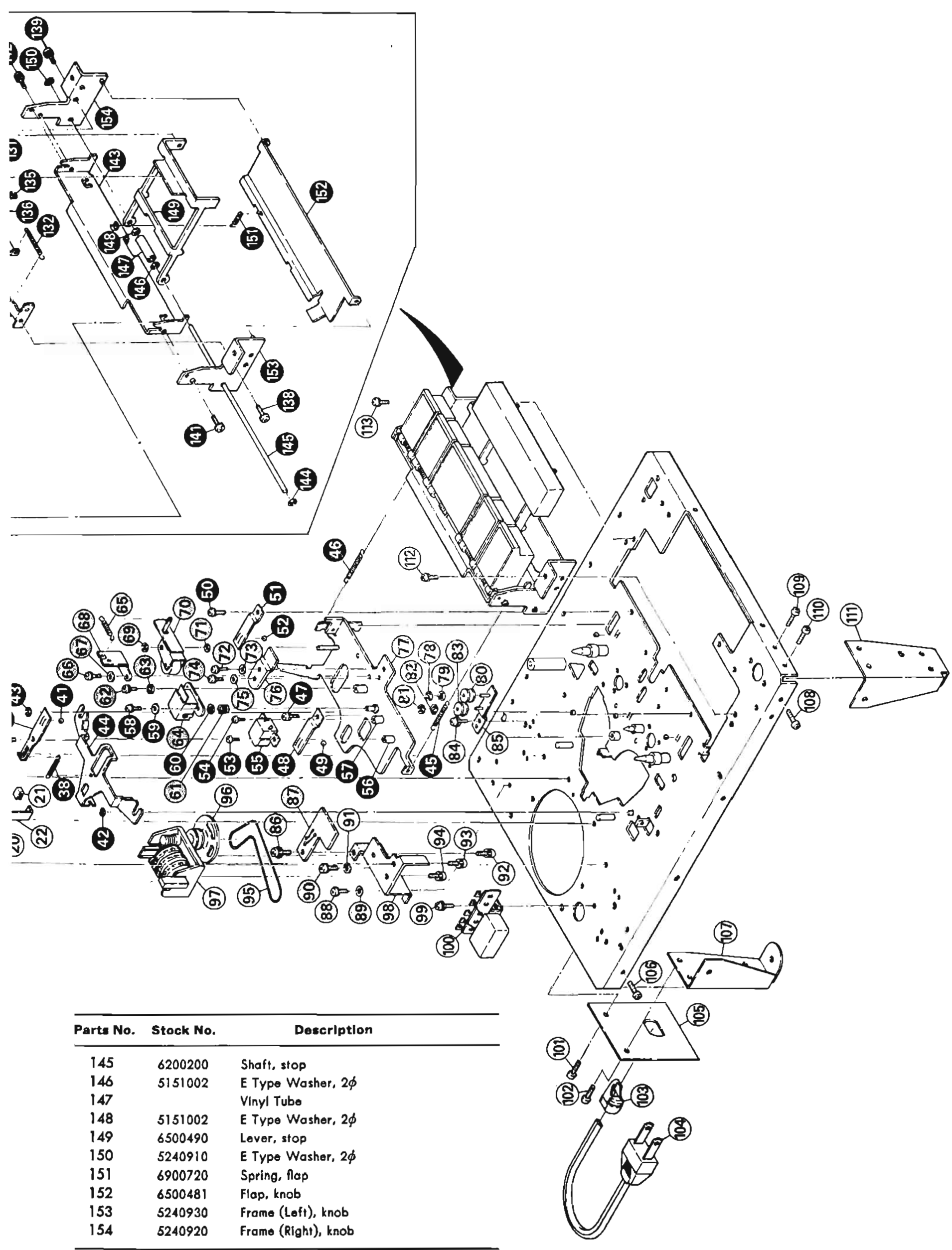

Parts No.	Stock No.	Description
145	6200200	Shaft, stop
146	5151002	E Type Washer, 2φ
147		Vinyl Tube
148	5151002	E Type Washer, 2φ
149	6500490	Lever, stop
150	5240910	E Type Washer, 2φ
151	6900720	Spring, flap
152	6500481	Flap, knob
153	5240930	Frame (Left), knob
154	5240920	Frame (Right), knob

6-4. Disassembly of the Mechanism (Bottom view)

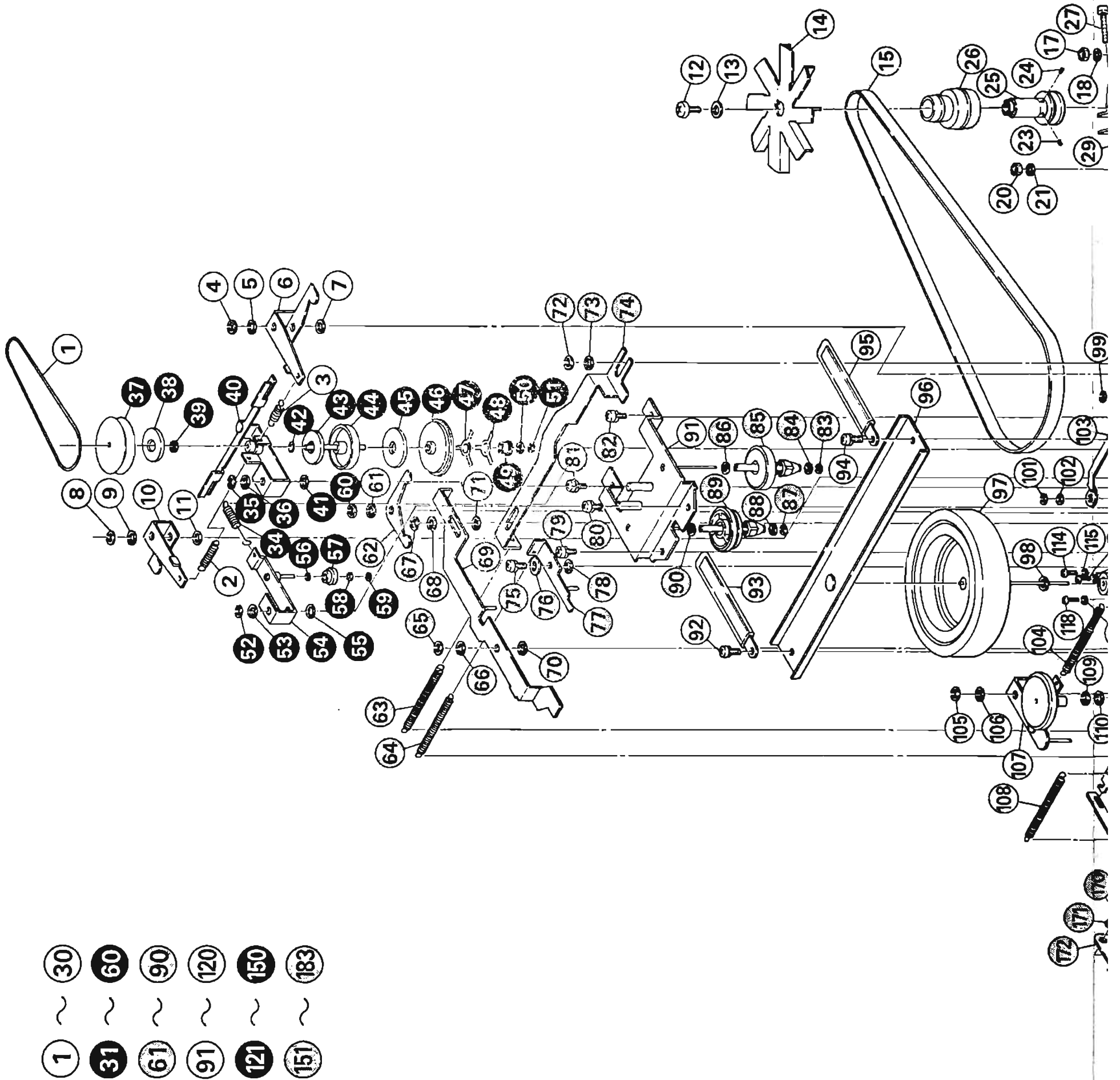

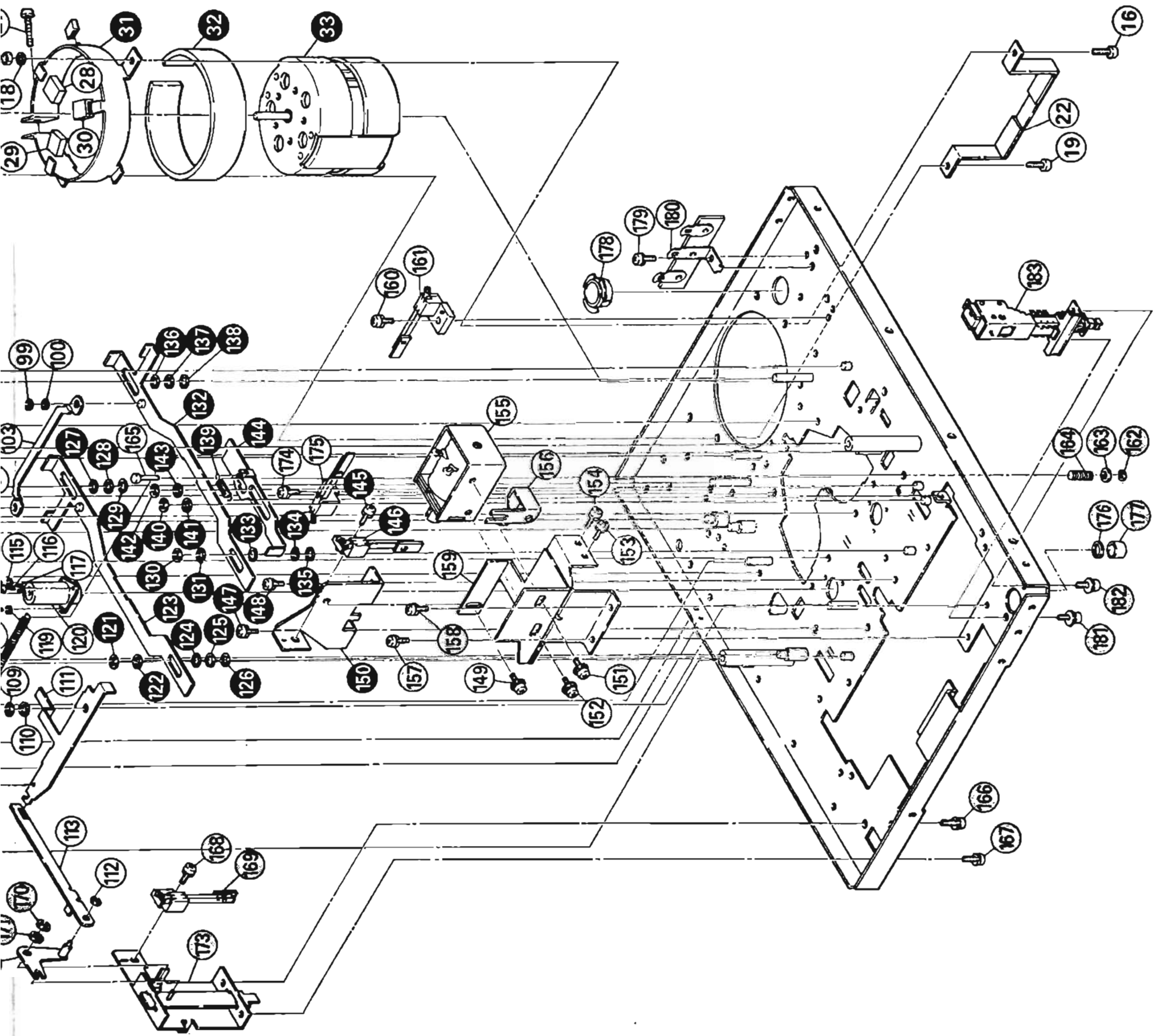

6-4. Disassembly of the Mechanism (Bottom View), Parts List

Parts No.	Stock No.	Description	Parts No.	Stock No.	Description
1	6030100	F.F. Belt	64	6900800	Spring, record lock plate
2	6900831	Spring (Right), F.F.	65	5151004	E Type Washer, 3φ
3	6900841	Spring (Left), F.F.	66	5180260	P Type Washer, 4φ
4	5151004	E Type Washer, 3φ	67	5151004	E Type Washer, 3φ
5	5180260	P Type Washer, 4φ	68	5180260	P Type Washer, 4φ
6	6500580	Lever (Right), F.F.	69	6510140	REC Link
7	5180260	P Type Washer, 4φ	70	5180260	P Type Washer, 4φ
8	5151004	E Type Washer, 3φ	71	5180260	P Type Washer, 4φ
9	5180260	P Type Washer, 4φ	72	5151004	E Type Washer, 3φ
10	6500590	Lever (Left), F.F.	73	5180260	P Type Washer, 4φ
11	5180260	P Type Washer, 4φ	74	6510150	REC Pusher
12	5160280	B Type Screw, M5 × 6	75	5101843	BSA Type Screw, M3 × 6
13		P Type Washer, 5φ	76	5180260	P Type Washer, 4φ
14	6190020	Motor Fan	77	6500520	Lock Plate, record
15	6030090	Capstan Belt	78	5180260	P Type Washer, 4φ
16	5101043	B Type Screw, M3 × 6	79	5101843	BSA Type Screw, M3 × 6
17	5110241	Hex. Nut, M3	80	5101843	BSA Type Screw, M3 × 6
18	5121340	S Type Washer, 3φ	81	5101843	BSA Type Screw, M3 × 6
19	5101043	B Type Screw, M3 × 6	82	5101843	BSA Type Screw, M3 × 6
20	5110241	Hex. Nut, M3	83	5190090	E Type Washer, 1.2φ
21	5121340	S Type Washer, 3φ	84	5180280	P Type Washer, 1.6φ
22	5260250	Motor Stay	85	7060100	Reel Hub Ass'y (Left)
23	5105640	SS Type Screw, M3 × 3	86	5180280	P Type Washer, 1.6φ
24	5105640	SS Type Screw, M3 × 3	87	5190090	E Type Washer, 1.2φ
25	6140050	Motor Capstan A	88	5180280	P Type Washer, 1.6φ
26	6140060	Motor Capstan B	89	7060093	Reel Hub Ass'y (Right)
27	5100249	B Type Screw, M3 × 16	90	5180280	P Type Washer, 1.6φ
28	5500510	Bushing, motor table	91	6610040	Spindle Base
29	5500510	Bushing, motor table	92	5101843	BSA Type Screw, M3 × 6
30	5500510	Bushing, motor table	93	3916021	Holder, lead wire
31	5260260	Motor Table	94	5101843	BSA Type Screw, M3 × 6
32	5500491	Motor Cushion	95	3916021	Holder, lead wire
33	4320250	Motor	96	5260220	Holder, capstan
34	6900850	Spring, reverse idler	97	7040181	Capstan Ass'y
35	5151004	E Type Washer, 3φ	98	5180330	P Type Washer, 2.5φ
36	5180260	P Type Washer, 4φ	99	5151002	E Type Washer, 2φ
37	6140070	F.F. Pulley	100	5180340	P Type Washer, 3φ
38	6930050	Oil Retainer	101	5151002	E Type Washer, 2φ
39	5180320	P Type Washer, 2φ	102	5180340	P Type Washer, 3φ
40	6310050	F.F. Metal	103	6500550	Brake Lever
41	5180260	P Type Washer, 4φ	104	6900661	Spring, PLAY idler
42	5180330	P Type Washer, 2.5φ	105	5151004	E Type Washer, 3φ
43	6930050	Oil Retainer	106	5180260	P Type Washer, 4φ
44	6200240	F.F. Idler Shaft	107	7060081	PLAY Idler Ass'y
45	6420020	Friction Retainer	108	6900810	Spring, PAUSE lever
46	6110060	F.F. Limb	109	5151004	E Type Washer, 3φ
47	6900750	Spring, idler	110	5180260	P Type Washer, 4φ
48	6900750	Spring, idler	111	6500540	PAUSE Lever (Right)
49	6200250	Bushing, F.F.	112	5151004	E Type Washer, 3φ
50	5180330	P Type Washer, 2.5φ	113	6510180	Linkage Plate, PAUSE
51	5151002	E Type Washer, 1.5φ	114	5101203	B Type Screw, M2 × 5
52	5151004	E Type Washer, 3φ	115	5121301	S Type Washer, 2φ
53	5180260	P Type Washer, 4φ	116	5101203	B Type Screw, M2 × 5
54	6500560	Arm, reverse idler	117	5121301	S Type Washer, 2φ
55	5180260	P Type Washer, 4φ	118	5101203	B Type Screw, M2 × 5
56	5180320	P Type Washer, 2φ	119	5121301	S Type Washer, 2φ
57	6120021	Idler, reverse	120	7040191	Metal Case Ass'y
58	5180320	P Type Washer, 2φ	121	5151004	E Type Washer, 3φ
59	5151002	E Type Washer, 1.5φ	122	5180260	P Type Washer, 4φ
60	5151004	E Type Washer, 3φ	123	6510200	F.F. Push Lever (Right)
61	5180260	P Type Washer, 4φ	124	5180260	P Type Washer, 4φ
62	6500510	Arm, record locker	125	5180260	P Type Washer, 4φ
63	6900760	Spring, record pusher	126	5180260	P Type Washer, 4φ

Parts No.	Stock No.	Description
127	5180260	P Type Washer, 4φ
128	5180260	P Type Washer, 4φ
129	5180260	P Type Washer, 4φ
130	5151004	E Type Washer, 3φ
131	5180260	P Type Washer, 4φ
132	6510210	F.F. Push Lever (Left)
133	5180260	P Type Washer, 4φ
134	5180260	P Type Washer, 4φ
135	5180260	P Type Washer, 4φ
136	5180260	P Type Washer, 4φ
137	5180260	P Type Washer, 4φ
138	5180260	P Type Washer, 4φ
139	6900770	Spring, EJECT lever
140	5151004	E Type Washer, 3φ
141	5180260	P Type Washer, 4φ
142	5151004	E Type Washer, 3φ
143	5180260	P Type Washer, 4φ
144	6510160	EJECT Lever
145	5101843	BSA Type Screw, M3×6
146	1190170	Leaf Switch, PLAY
147	5101843	BSA Type Screw, M3×6
148	5101843	BSA Type Screw, M3×6
149	5101843	BSA Type Screw, M3×6
150	5241020	Holder, auto Shut-off switch
151	5101943	BSB Type Screw, M3×6
152	5101943	BSB Type Screw, M3×6
153	5101843	BSA Type Screw, M3×6
154	5101843	BSA Type Screw, M3×6
155	4340120	Plunger Solenoid
156	6500500	Auto Stop Lever
157	5101843	BSA Type Screw, M3×6
158	5101843	BSA Type Screw, M3×6
159	5240950	Bracket, plunger solenoid
160	5101843	BSA Type Screw, M3×6
161	1190180	Leaf Switch, REWIND
162	5151002	E Type Washer, 2φ
163	5120141	P Type Washer, 3φ
164	6900790	Spring, eject lever stopper
165	6210291	Stopper, EJECT lever
166	5101843	BSA Type Screw, M3×6
167	5101843	BSA Type Screw, M3×6
168	5101843	BSA Type Screw, M3×6
169	1190180	Leaf Switch, PAUSE
170	5151004	E Type Washer, 3φ
171	5180260	P Type Washer, 4φ
172	6500530	PAUSE Lever
173	7120012	PAUSE Switch Ass'y
174	5101843	BSA Type Screw, M3×6
175	1190170	Leaf Switch, F.F.
176	6930040	Oil Retainer
177	5260290	Bushing, Capstan
178	5616120	Snap Bushing
179	5101843	BSA Type Screw, M3×6
180	2110141	Lug Terminal
181	5101843	BSA Type Screw, M3×6
182	5101843	BSA Type Screw, M3×6
183	1130680	Push Switch, POWER

7. SCHEMATIC DIAGRAM

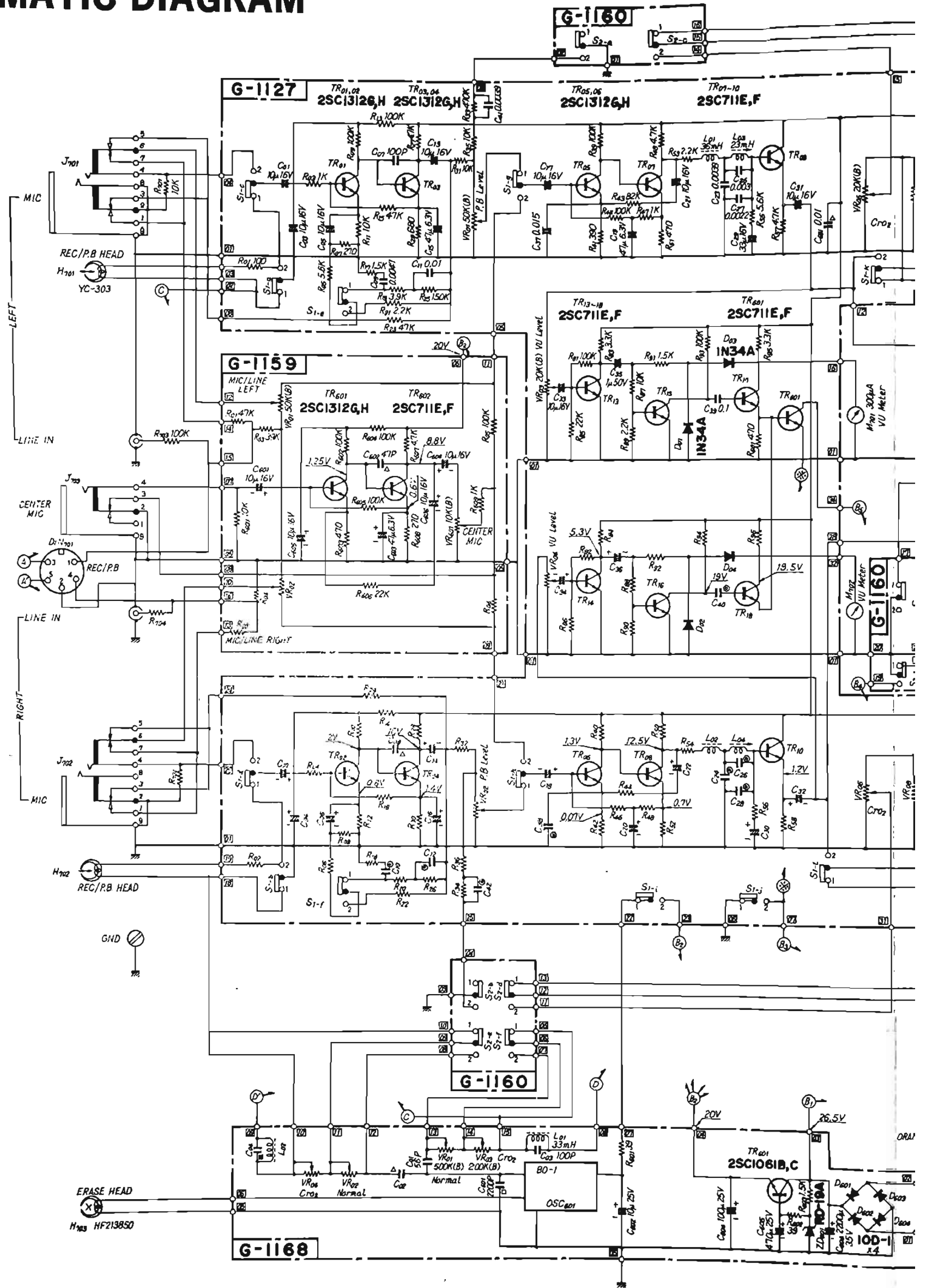

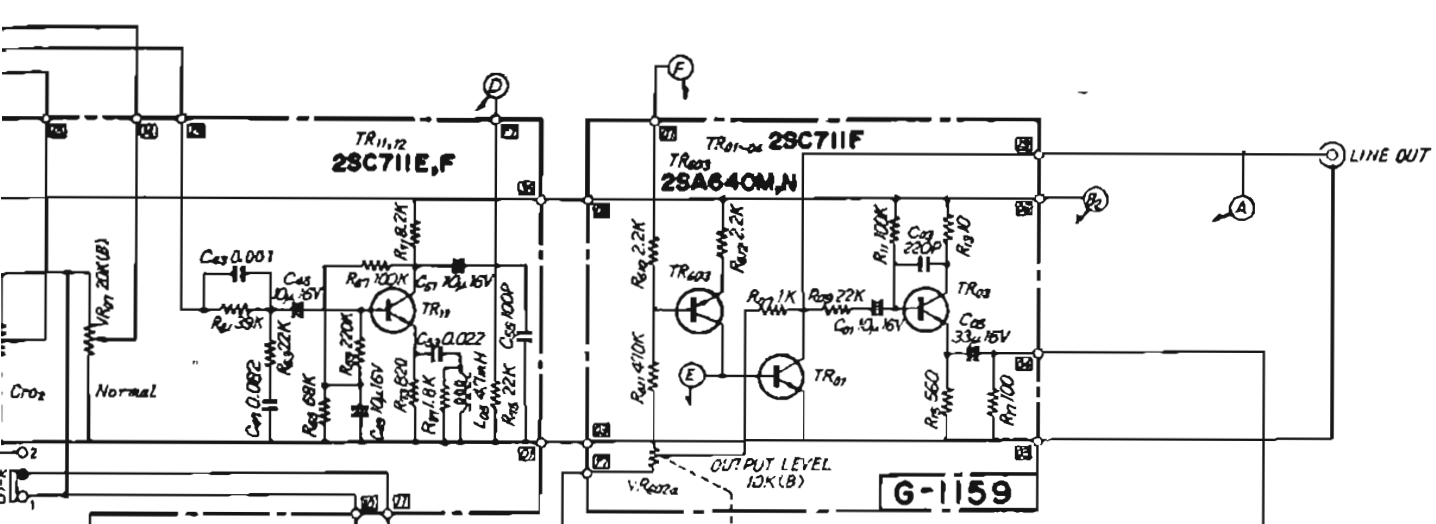

- SWITCHES**
- PLAY REC S₁₋₂
 - 1. PLAY
 - 2. REC
 - TAPE SELECTOR S₂₋₂
 - 1. NORMAL
 - 2. CHROMIUM
 - DOLBY NR S₃₋₂
 - 1. OUT
 - 2. IN
 - PAUSE S₄
 - 1. OFF
 - 2. ON
 - POWER S₅
 - 1. OFF
 - 2. ON
 - FF S₆
 - 1. OFF
 - 2. ON
 - REV S₇
 - 1. OFF
 - 2. ON
 - PLAY S₈
 - 1. OFF
 - 2. ON

- SYMBOL**
- CERAMIC
 - MYLAR
 - MICA
 - STYROL
- RESISTOR**
- J Capacitance Tolerance *5%
- ALL Resistors 1/4 Watts
- Unless Otherwise Noted

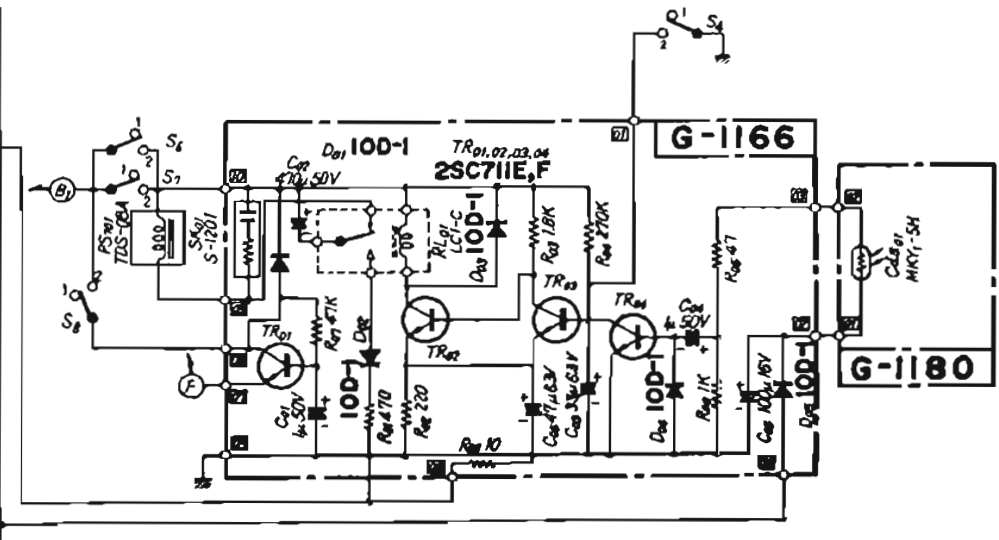
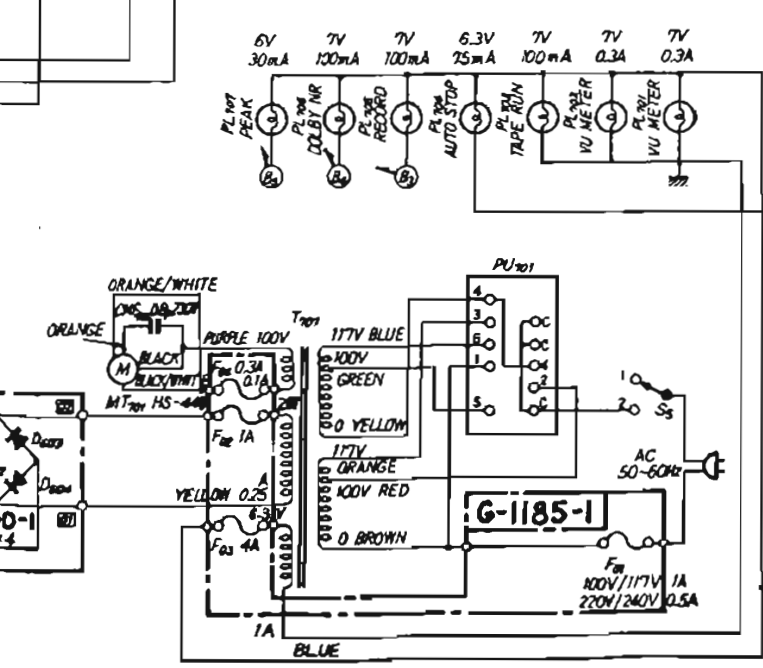
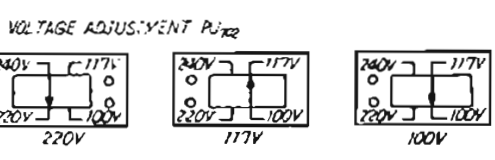
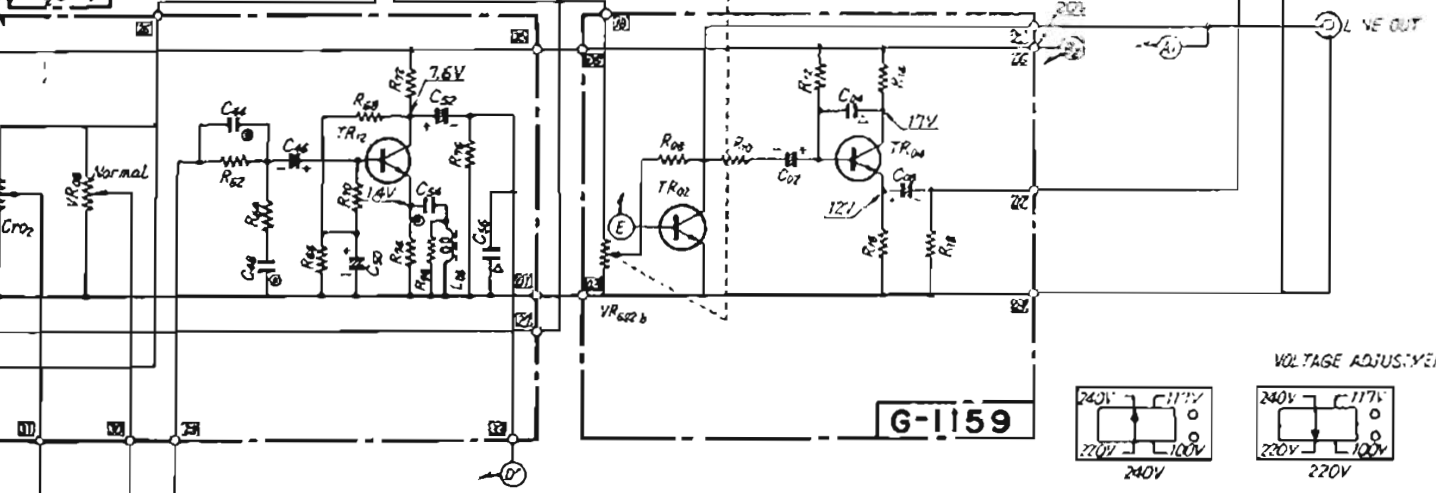
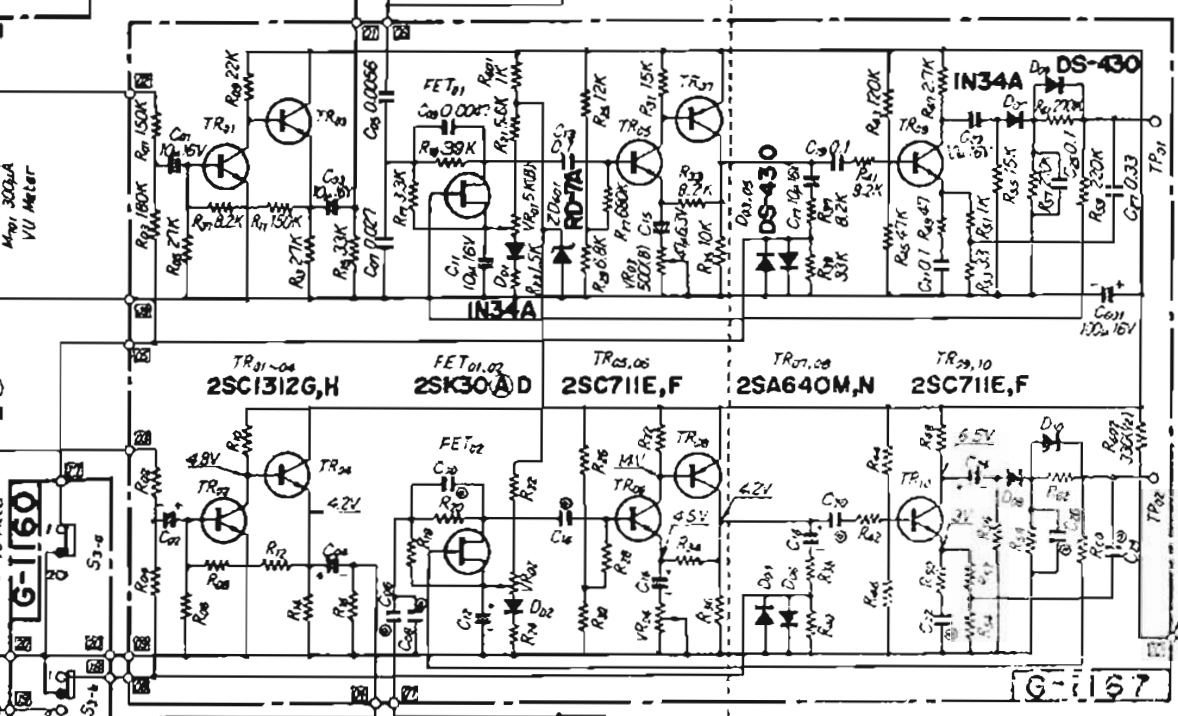

8. REPLACEMENT OF MAIN PARTS

*Each number (①, ②....) corresponds to the number shown in Exploded Views.

8-1. Replacement of Top Cover Ass'y (See 6-1 on page 18)

- 1) Remove screws ①, ④, washers ②, ③, ⑤, ⑥, and cassette lid ⑦.
- 2) Remove screws ⑧, ⑳, ㉑, ㉒, ㉓, ㉔ and ㉕, and Top Cover Ass'y ㉖ will be off.

8-2. Replacement of Reel Hub Ass'y (See 6-4 on page 23)

- 1) Remove Top Cover Ass'y ㉖ (Same as steps 1), 2) in Replacement of Top Cover Ass'y).
- 2) Remove well-stay ㉗ (See 6-3 on page 22).
- 3) Remove washers ㉘, ㉙, ㉚, ㉛, and Reel Hub Ass'y will be off.

*After replacing Reel Hub Ass'y ㉜, ㉝, perform running test (aging test) for 4~5 minutes in the PLAY and REWIND modes installing cassette tape.

8-3. Replacement of Motor (See 6-4 on page 23)

- 1) Remove Top Cover Ass'y ㉖ (See as steps 1), 2) in Replacement of Top Cover Ass'y).
- 2) Remove screw ㉞, washer ㉟, motor fan ㊱ and F.F. belt ㊲, capstan belt ㊳.
- 3) Remove screws ㊴, ㊵, washers ㊶, ㊷, and motor stay ㊸.
- 4) After loosening screw ㊹, remove motor table ㊺ and motor cushion ㊻, and the motor will be off.

*After replacement, confirm the level of the motor by screw ㊹ certainly.

9. PACKING LIST

Parts No.	Stock No.	Description
1	9010070	Inner Packing (Upper)
2	9030100	Stylofoam Packing
3	9010070	Inner Packing (Lower)
4	9000301	Carton Case

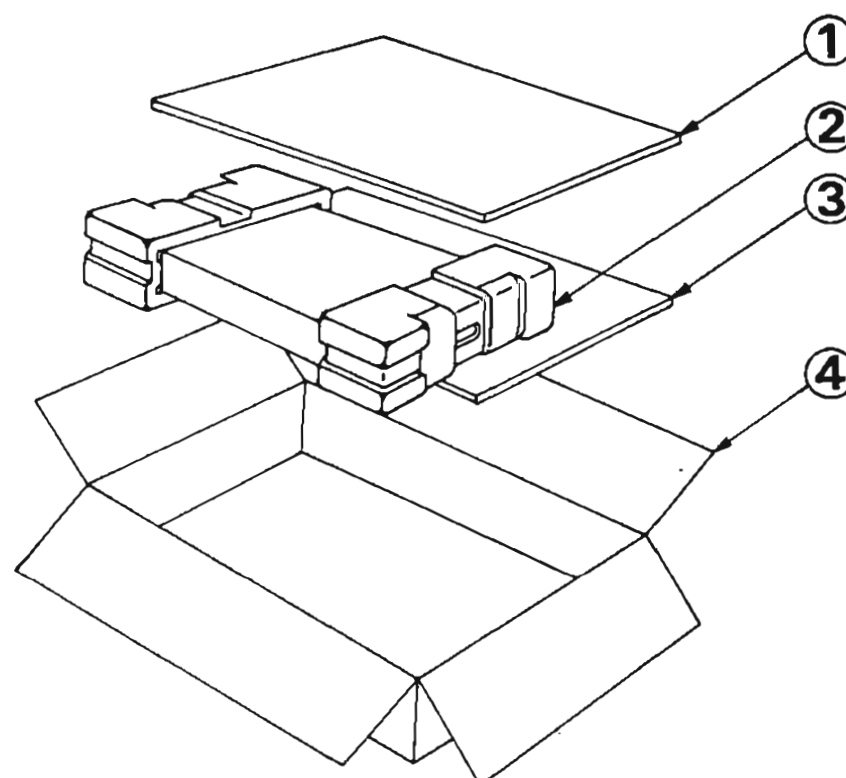

10. ACCESSORY PARTS LIST

Parts No.	Stock No.	Description
	9406021	Polishing Cloth
	9430030	Head Cleaning Pen
	3810080, 1	Pin Plug Cord
	9200220	Operating Instructions



SANSUI ELECTRIC CO., LTD.
14-1, 2-chome, Izumi, Suginamiku, Tokyo 168, Japan.
TELEPHONE: (03) 323-1111 / TELEX: 232-2076

SM010

Printed In Japan (34040M)