

SERVICE MANUAL

FULL REMOTE CONTROL SYSTEM
COMPU-EQUALIZER

SANSUI SE-88



CAUTION

1. Parts identified by the Δ symbol on the schematic diagram and the parts list are critical for safety. Use only replacement parts that have critical characteristics recommended by the manufacturer.
2. Make leakage-current or resistance measurements to determine that exposed parts are acceptably insulated from the supply circuit before returning the appliance to the customer.

•SPECIFICATIONS

Input sensitivity and impedance (1 kHz)

INPUT, TAPE PLAY-1,2
..... 150mV/47 kohms

Output level and impedance (1 kHz)

TAPE REC-1,2 150mV/1.5 kohms

OUTPUT 150mV/1.5 kohms

(Maximum output level: 5V into 47 kohms at 0.5% total harmonic distortion)

Total harmonic distortion (2V, 20 Hz to 20 kHz)

INPUT, TAPE PLAY-1,2
..... 0.008%

Frequency response (at 0.5V, Equalizer controls: "0" position)

INPUT, TAPE PLAY-1,2
..... 10 Hz to 100 kHz,
+1.0 dB, -3.0 dB

Signal to noise ratio (Short-circuit, A-network)

INPUT, TAPE PLAY-1,2
..... 110 dB

Equalizer frequency 25 Hz, 50 Hz, 100 Hz,
160 Hz, 250 Hz, 400 Hz,
630 Hz, 1 kHz, 1.6 kHz,
2.5 kHz, 4 kHz, 6.3 kHz,
10 kHz, 20 kHz

Level variation range ± 10 dB

Others

Power voltage 120, 220, 240 V
(50/60 Hz)

For U.S.A. and Canada

..... 120 V (60 Hz)

Power consumption 20 watts

Dimensions 430 mm (16-15/16") (W)
111 mm (4-3/8") (H)
303 mm (11-15/16") (D)

Weight 4.1 kg (9.0 lbs) net
5.5 kg (12.0 lbs) packed

- Design and specifications subject to change without notice for improvements.
- Due to local laws and regulations, this unit sold in some areas are not equipped with variable voltage selectors.

Sansui

SANSUI ELECTRIC CO., LTD.

1. BLOCK DIAGRAM

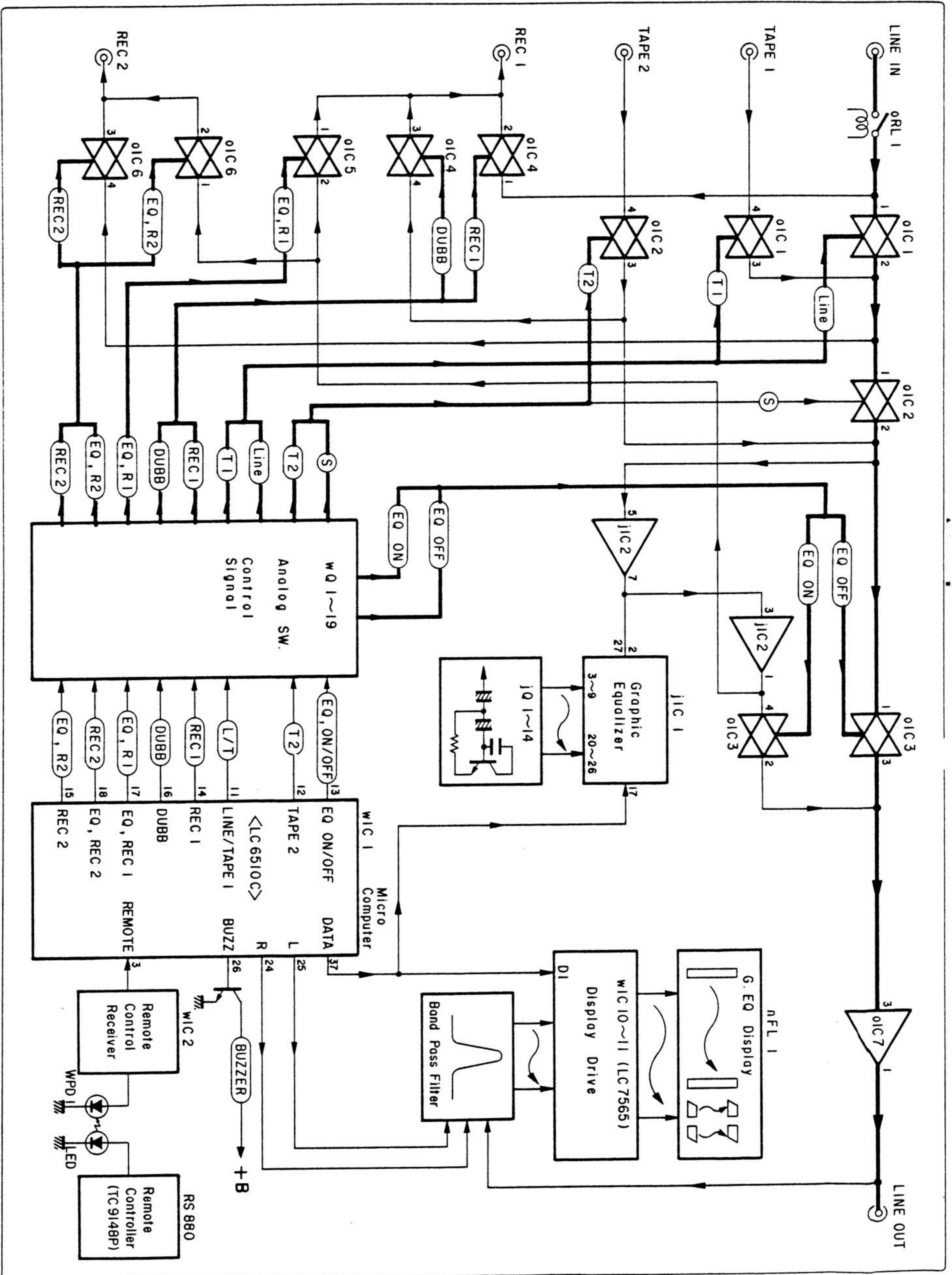

2. INTERIOR BLOCK DIAGRAM & TERMINAL FUNCTION OF IC

•LC7520 (Graphic Equalizer IC)

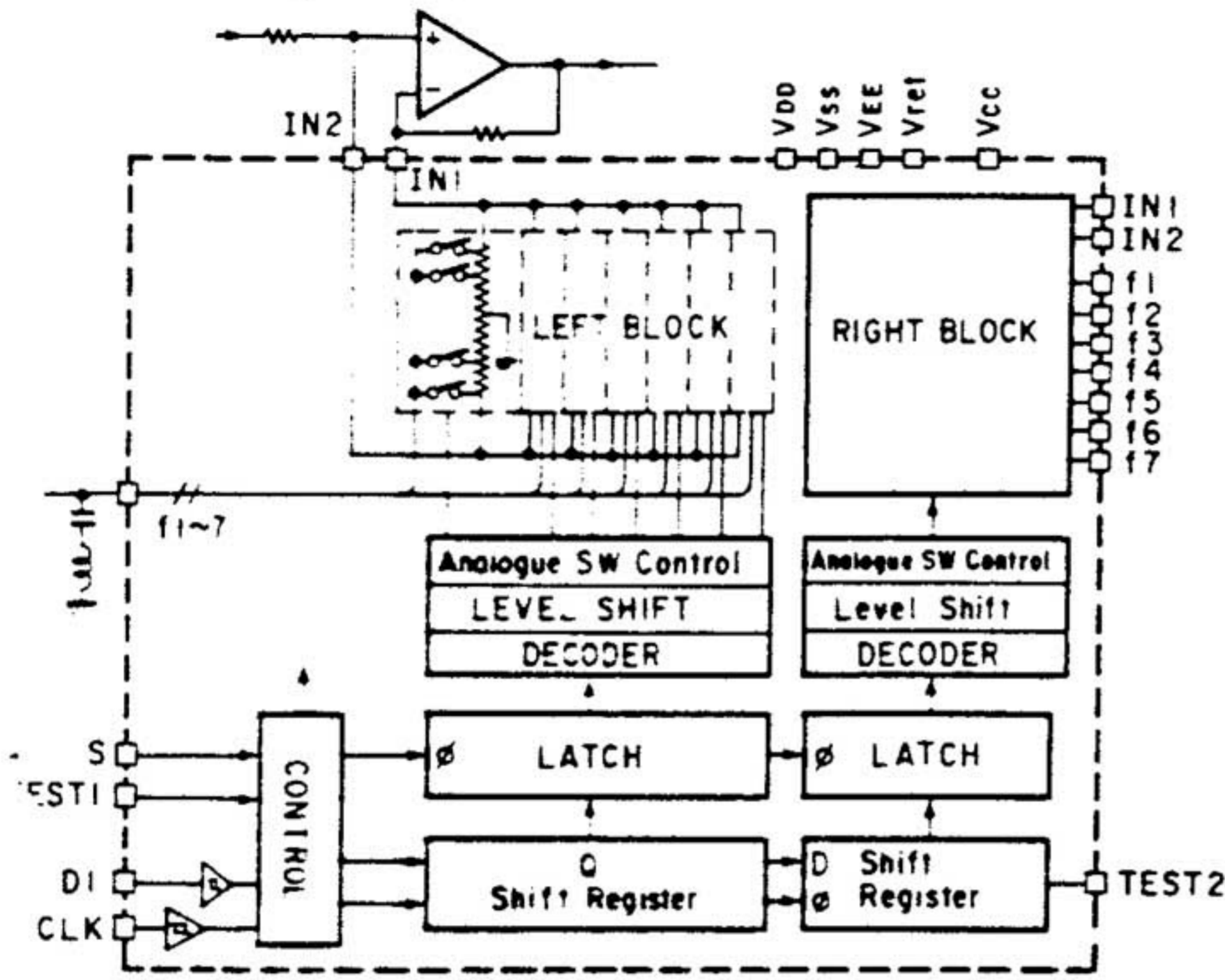

< Functions >

1. Seven frequency band circuits are incorporated for each right and left side.
2. Frequency is variable at 2 dB per step within a range of ± 10 dB (11 positions per band) by the use of UP/DOWN keys.
3. A microcomputer is used for control. Two control lines are provided.

< Data bits >

78 bits in total

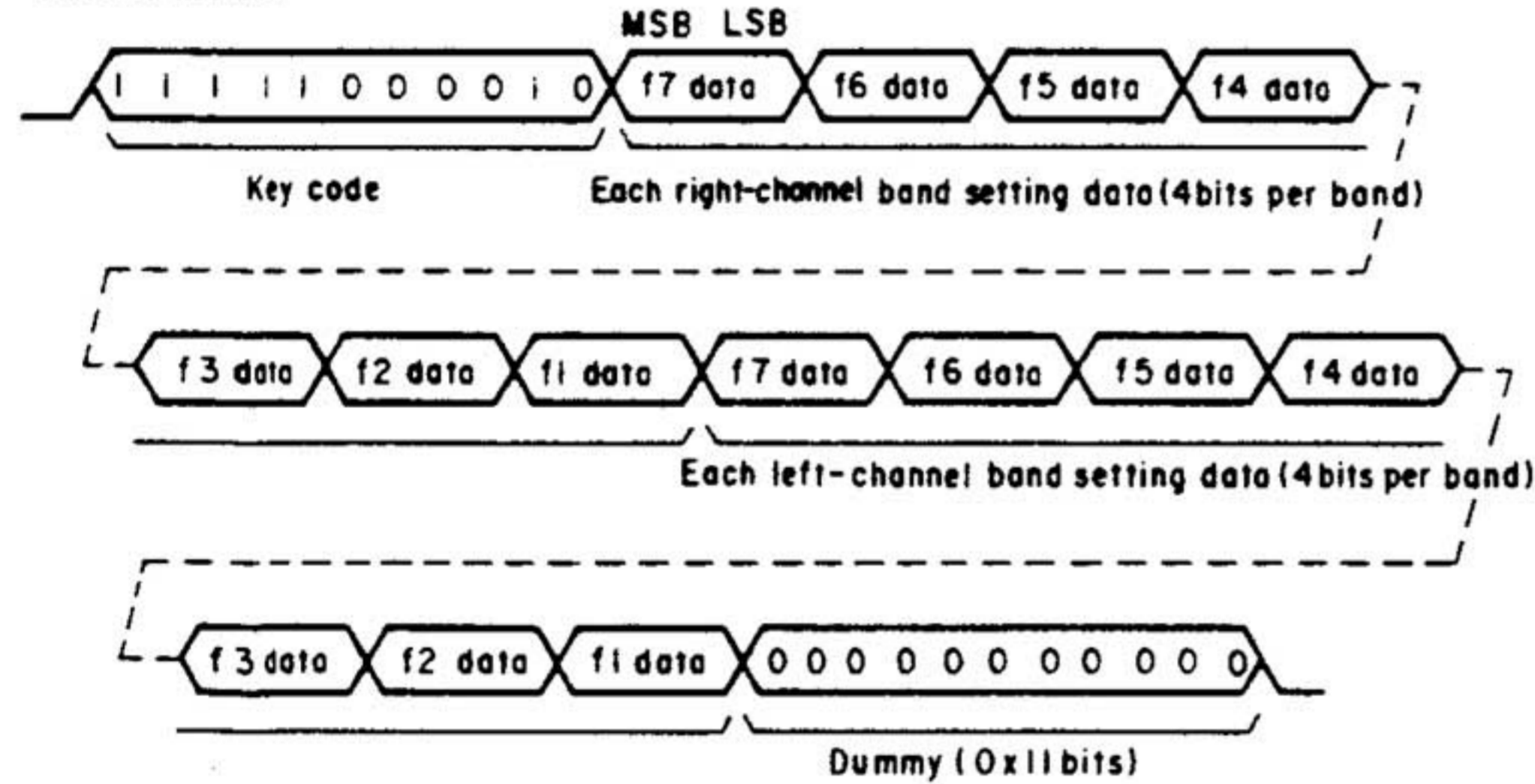

< Output timing chart between clock and data from microcomputer >

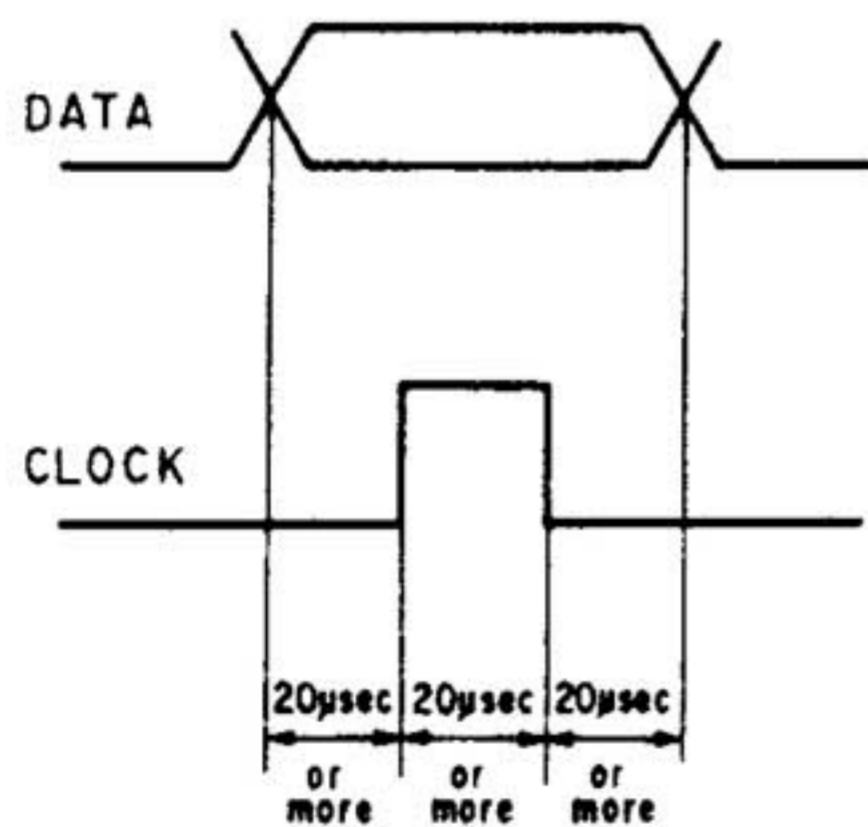

< Description of Terminals >

Pin No.	Terminal Name	Description
10	V _{DD}	Power terminal for audio signal +18V TYP
12	V _{rel}	Power terminal for logic driving V _{DD} -5V TYP
18	V _{SS}	Power terminal for ground 0V
19	V _{EE}	Power terminal for audio signals -18V TYP
13	V _{CC}	Power terminal -5V
17	D	*CPU data input terminal *Schmitt inverter type
16	CLK	*CPU CLK input terminal *Schmitt inverter type
1,28 2,27	IN1 IN2	*Audio signal input terminals *IN1 is usually connected to an inversion input of an operational amplifier. *IN2 is usually connected to a non-inversion input of an operational amplifier. *Provided for each right and left.
9-3 26-20	f1-f7	*Band pass filter connecting terminals *14 terminals in total (f1 to f7 for each side)
11	S	*Selector terminal (when two chips are used) *In response to "1", key code 7C3 is connected to V _{CC} *In response to "0", key code 7C2 is connected to V _{rel}
14	TEST1	*IC internal-function test terminal
15	TEST2	*Open in usual

< Band setting data codes >

	MSB	LSB		MSB	LSB
+10 dB	0	1 0 1	-2 dB	1	0 0 1
+8	0	1 0 0	-4	1	0 1 0
+6	0	0 1 1	-6	1	0 1 1
+4	0	0 1 0	-8	1	1 0 0
+2	0	0 0 1	-10	1	1 0 1
0	0	1 1 0			

•M5218P (Operation AMP. IC)

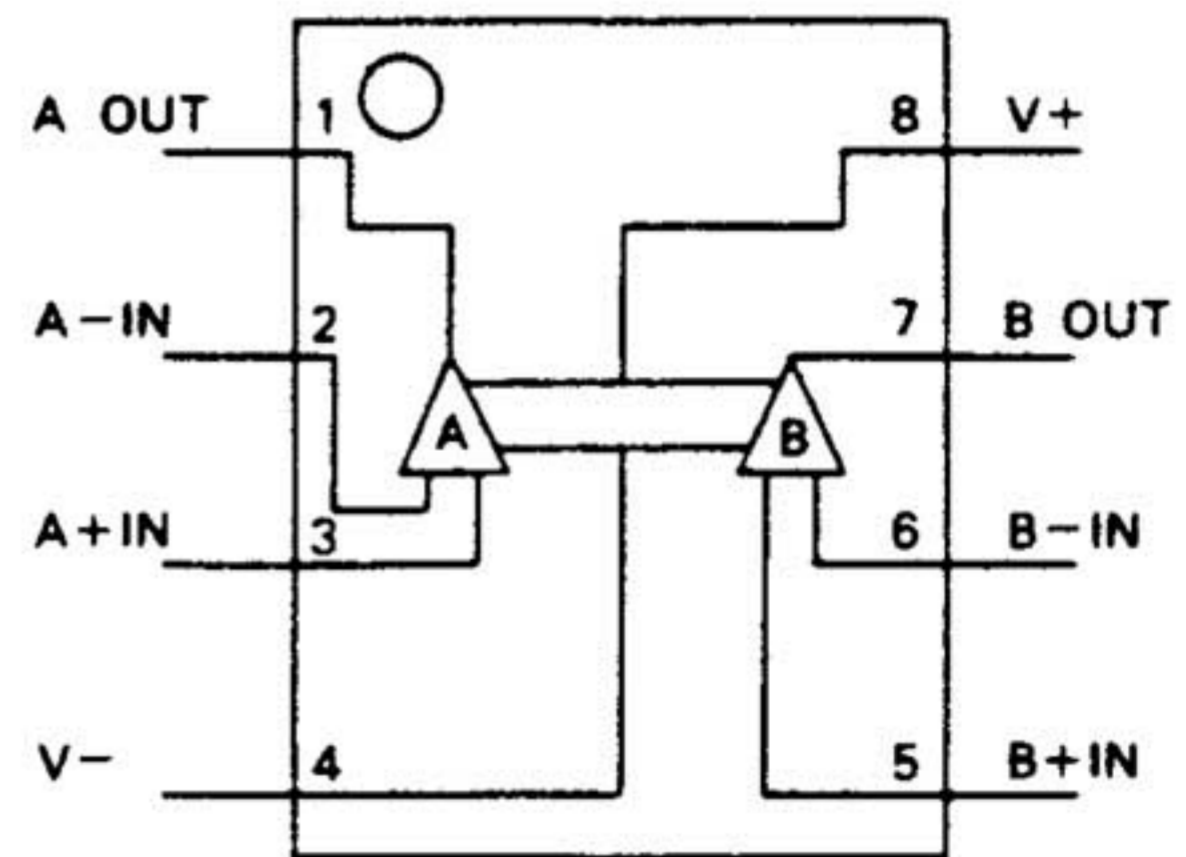

•LC4066BH (Analog Switch IC)

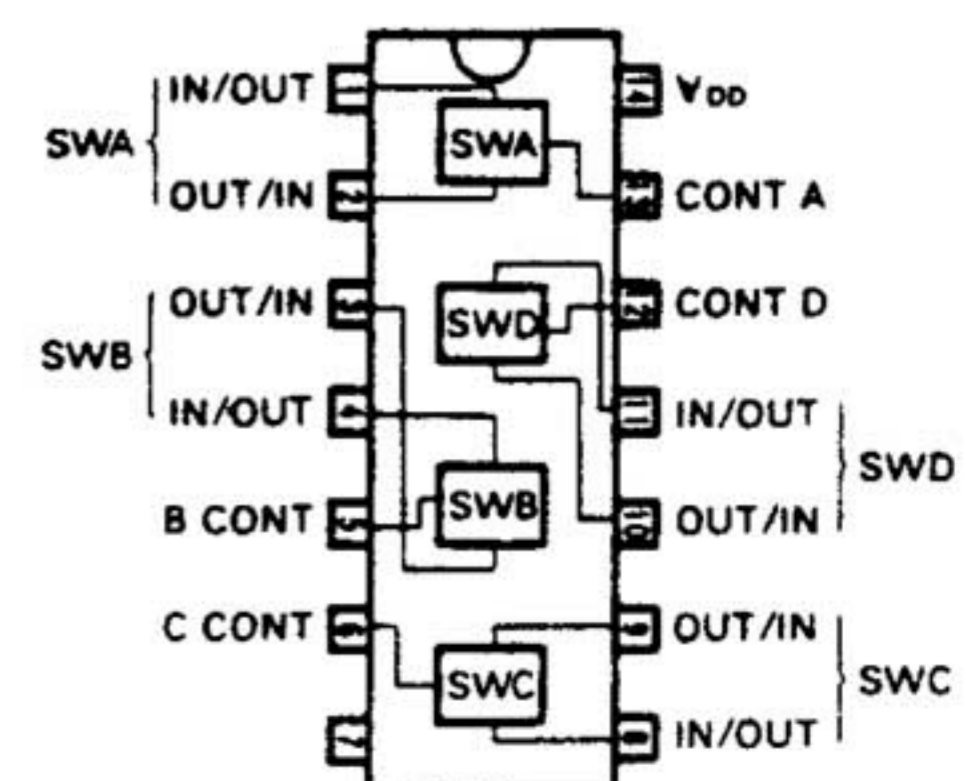

•LC7565 (G•EQ Display Driver IC)

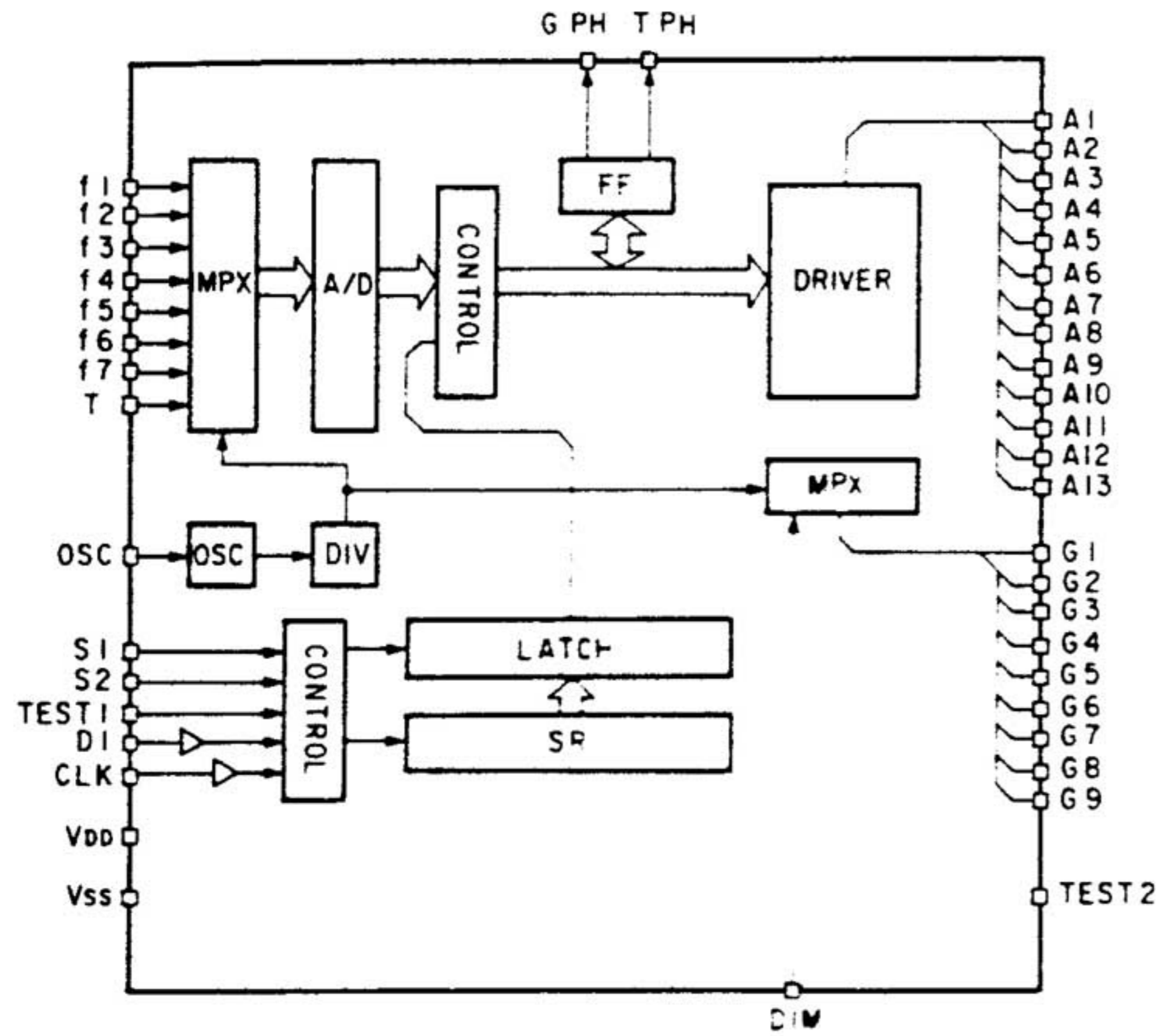

< Description of Terminals >

Pin No.	Terminal Name	Description
42	V _{DD}	Power terminal +5V Typ
19	V _{SS}	Power terminal GND
17	DI	CPU data input terminal
18	CLK	CPU CLK input terminal
15	S1	Selection Terminal (When plural chips are used. 4 pieces in maximum).
16	S2	
21	G•PH	C, R connecting terminal. The CR determines a peak hold reset time to display graphic equalizer in spectrum analyzer fashion.
22	T•PH	C, R connecting terminal. The CR determines a peak hold reset time in TOTAL display.
32	DIM	Terminal for controlling dimmer by directly driving the IC (when not controller by CPU). Dimmer is on at "1" but off at "0".
31 ~ 25, 24	f1 ~ f7, T	Rectified audio signal voltage input terminal
20	OSC	Open-drain type output buffer Terminal for externally connecting C and R for oscillator
2 ~ 14	A1 ~ A13	Open-drain driver. Anode driven type
41 ~ 33	A13 G1 ~ G9	Open-drain driver. Grid driven type

< Data Code >

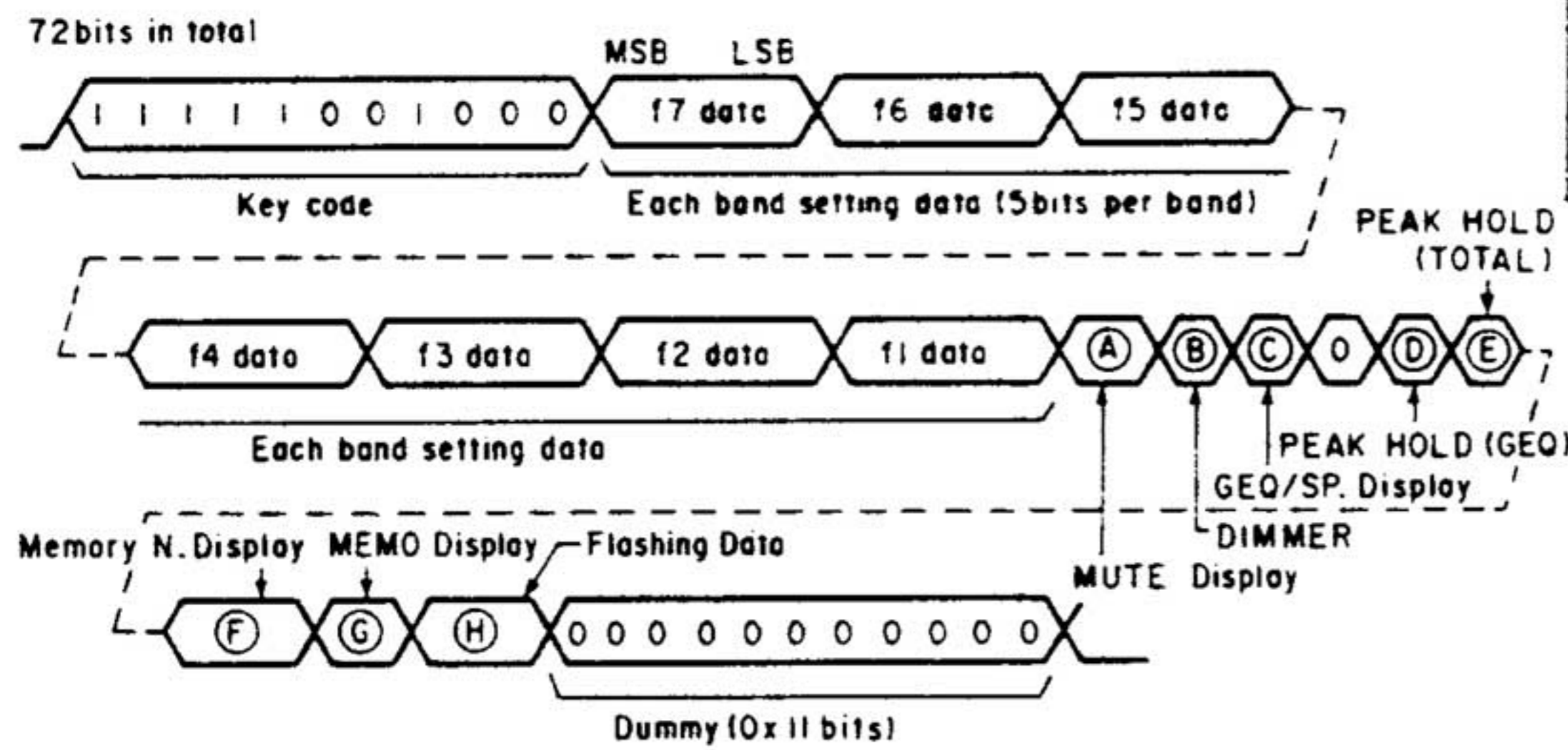

< Band Setting Data Code >

	MSB	LSB
+12dB	1	1 1 0 0
+10	1	1 0 1 0
+8	1	1 0 0 0
+6	1	0 1 1 0
+4	1	0 1 0 0
+2	1	0 0 1 0
0	1	0 0 0 0
-2	0	1 1 1 0
-4	0	1 1 0 0
-6	0	1 0 1 0
-8	0	1 0 0 0
-10	0	0 1 1 0
-12	0	0 1 0 0

① MUTE Display	② DIMMER	③ GEQ/Display	④ PEAK HOLD (GEQ)	⑤ PEAK HOLD (TOTAL)
OFF 0 0	OFF 0	GEQ 0	OFF 0	OFF 0
ON 0 1	ON 1	SPEANA 1	ON 1	ON 1

⑥ Memory No. Display	⑦ MEMO Display	⑧ Flashing Data
OFF 0 0 0	OFF 0 0	OFF 0 0 0
M1 0 0 1	ON 0 1	f ₁ 0 0 1
M2 0 1 0		f ₂ 0 1 0
M3 0 1 1		f ₃ 0 1 1
M4 1 0 0		f ₄ 1 0 0
M5 1 0 1		f ₅ 1 0 1
FLAT 1 1 1		f ₆ 1 1 0
		f ₇ 1 1 1

•LA7224 (Remote Control Receiver IC)

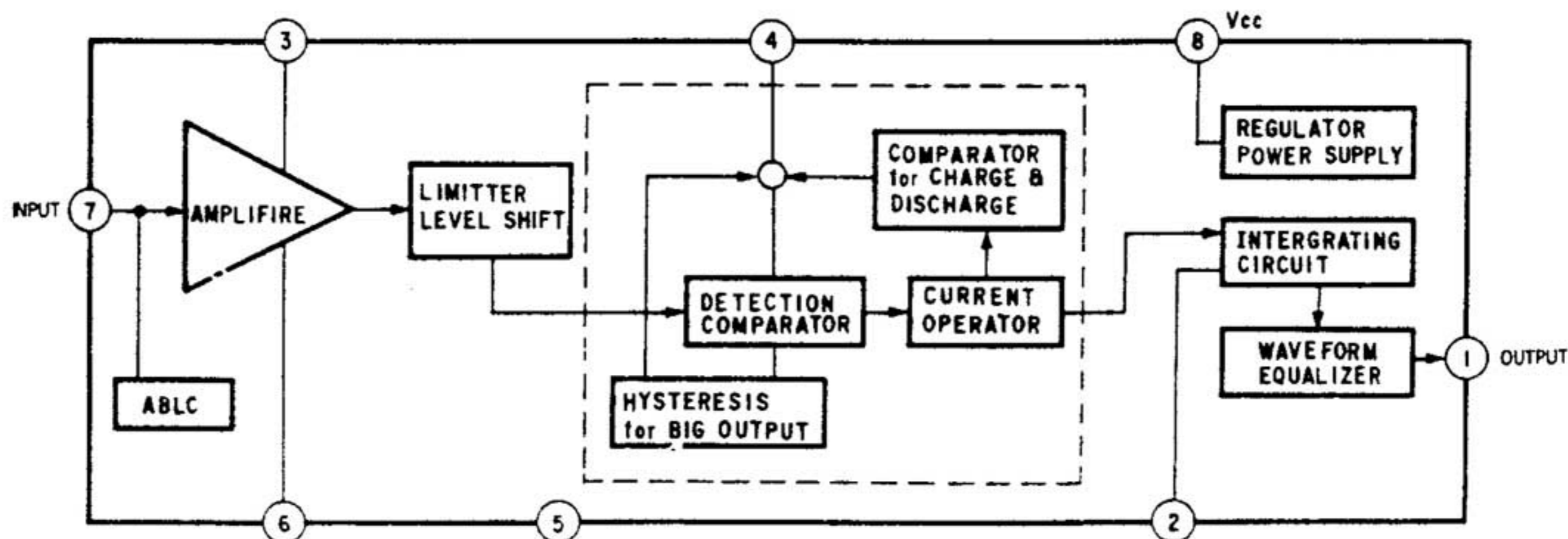

3. FUNCTION OF MICRO COMPUTER IC & REMOTE CONTROLLER

•Terminal Name of Micro Computer IC LC6510C

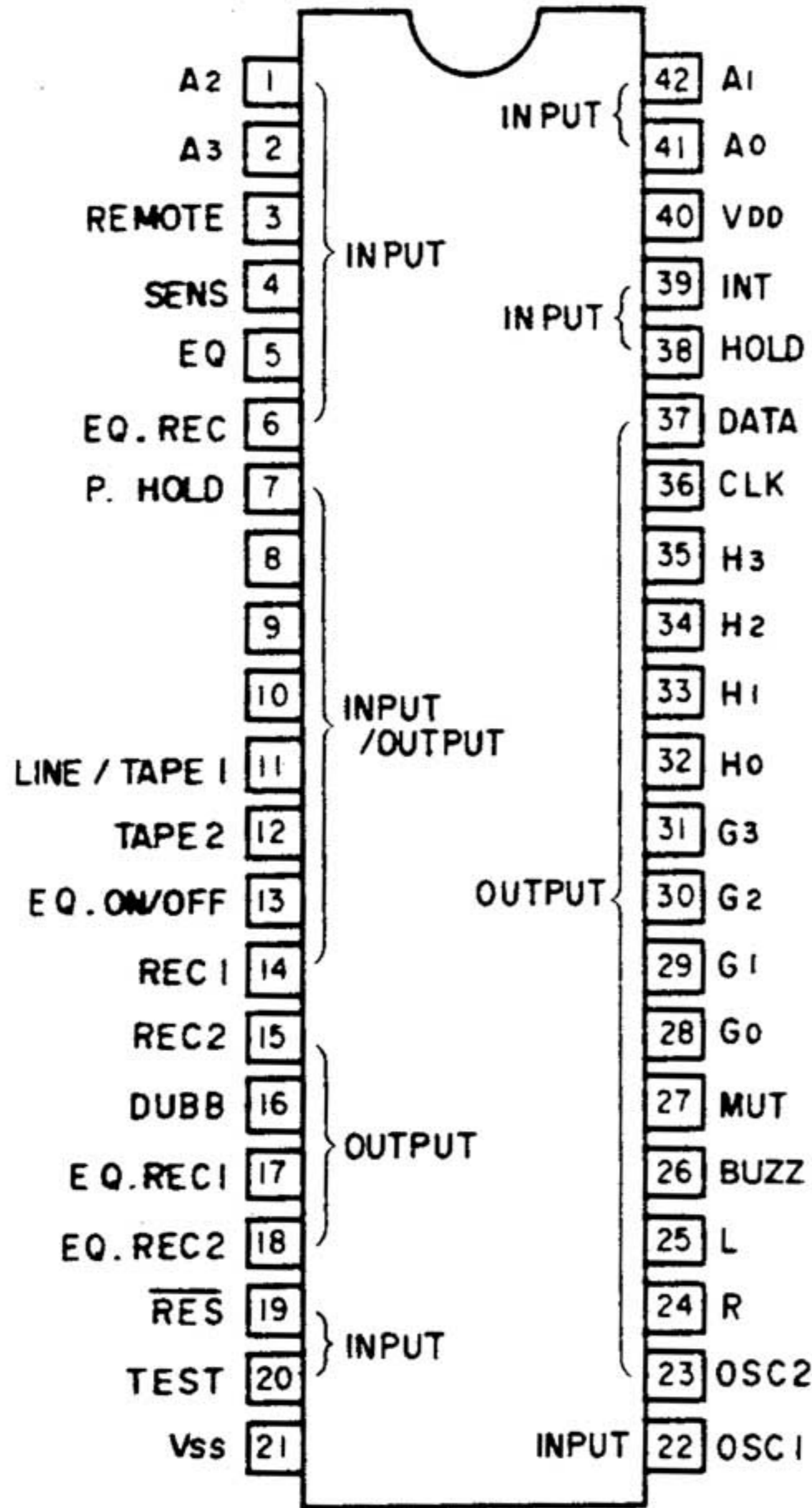

•Data Code of Remote Controller

Key No.	KEY NAME	H	S ₁	S ₂	D ₁	D ₂	D ₃	D ₄	D ₅	D ₆
1	G. EQ UP	1	0	0	1	0	0	0	0	0
2	G. EQ DOWN	1	0	0	0	1	0	0	0	0
3	G. EQ	1	0	0	0	0	1	0	0	0
4	SPEANA	1	0	0	0	0	0	1	0	0
5	REVERSE	1	0	0	0	0	0	0	1	0
6	CANNEL MODE	1	0	0	0	0	0	0	0	1
7	FLAT	0	1	0	1	0	0	0	0	0
8	TAPE 2	0	1	0	0	1	0	0	0	0
9	TAPE 1	0	1	0	0	0	1	0	0	0
10	LINE	0	1	0	0	0	0	1	0	0
11	G. EQ ON/OFF	0	1	0	0	0	0	0	1	0
12	G. EQ REC	0	1	0	0	0	0	0	0	1
13	MEMORY	0	0	1	1	0	0	0	0	0
14	M1	0	0	1	0	1	0	0	0	0
15	M2	0	0	1	0	0	1	0	0	0
16	M3	0	0	1	0	0	0	1	0	0
17	M4	0	0	1	0	0	0	0	1	0
18	M5	0	0	1	0	0	0	0	0	1
1-2	25Hz	1	0	0	1	1	0	0	0	0
1-3	50Hz	1	0	0	1	0	1	0	0	0
1-4	100Hz	1	0	0	1	0	0	1	0	0
1-5	160Hz	1	0	0	1	0	0	0	1	0
1-6	250Hz	1	0	0	1	0	0	0	0	1
2-3	400Hz	1	0	0	0	1	1	0	0	0
2-4	630Hz	1	0	0	0	1	0	1	0	0
2-5	1kHz	1	0	0	0	1	0	0	1	0
2-6	1.6kHz	1	0	0	0	1	0	0	0	1
3-4	2.5kHz	1	0	0	0	0	1	1	0	0
3-5	4kHz	1	0	0	0	0	1	0	1	0
3-6	6.3kHz	1	0	0	0	0	1	0	0	1
4-5	10kHz	1	0	0	0	0	0	1	1	0
4-6	20kHz	1	0	0	0	0	0	1	0	1

* Remote Inputs are Active "L".

•Input Key Matrix of Remote Controller

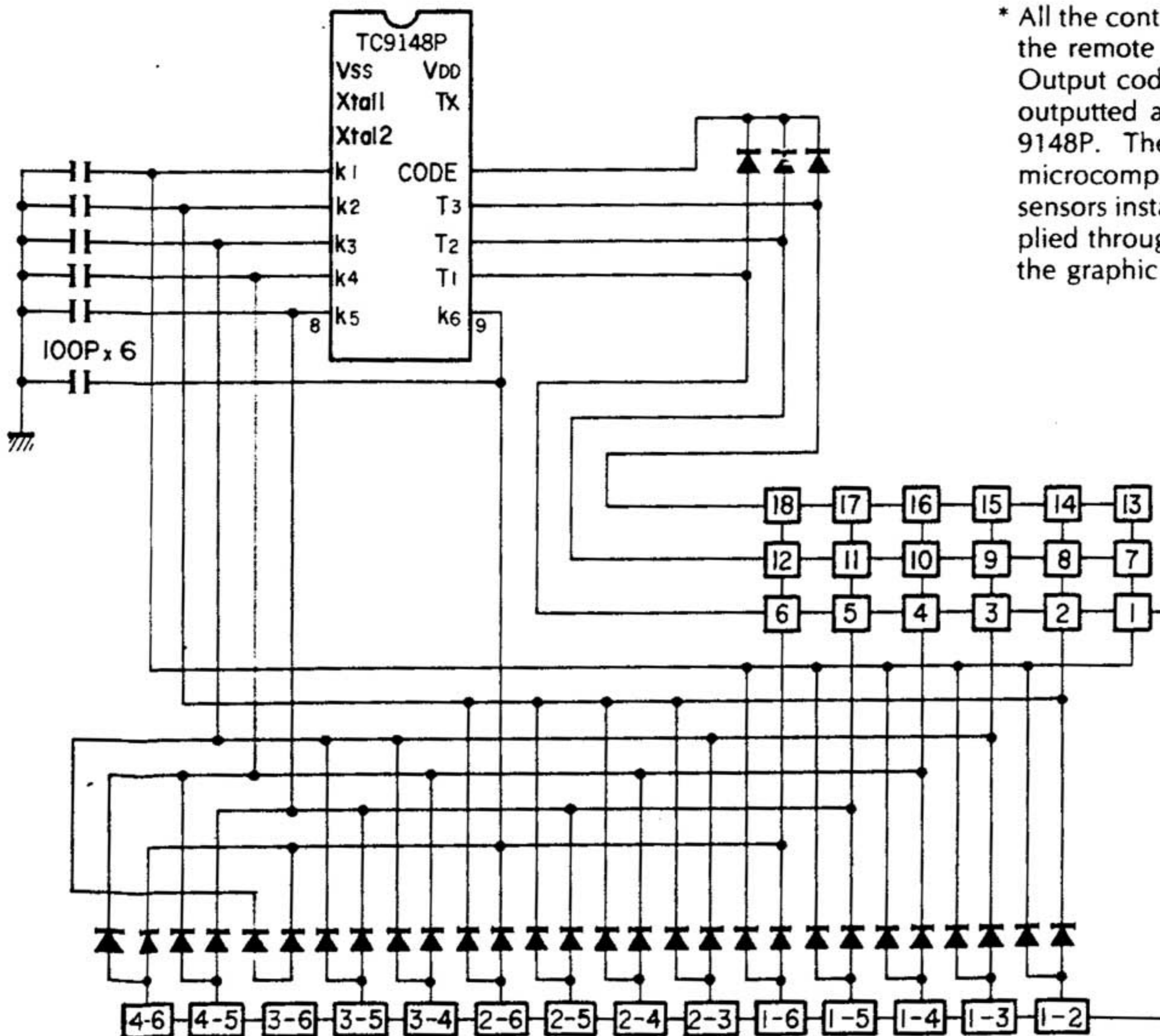

* All the control switches except the hold-peak switch are installed in the remote controller.

Output codes selected and entered through the input keys are all outputted as serial data through TX OUT terminal (Pin 15) of TC 9148P. These data are inputted to REMOTE terminal (Pin 3) of microcomputer IC LC6510C after having passed through the photo-sensors installed in the set body. On the basis of the input data applied through REMOTE terminal, the microcomputer controls both the graphic equalizer IC and the analog switch IC.

•TC9148P (Infrared Remote-Control Transmitter IC)

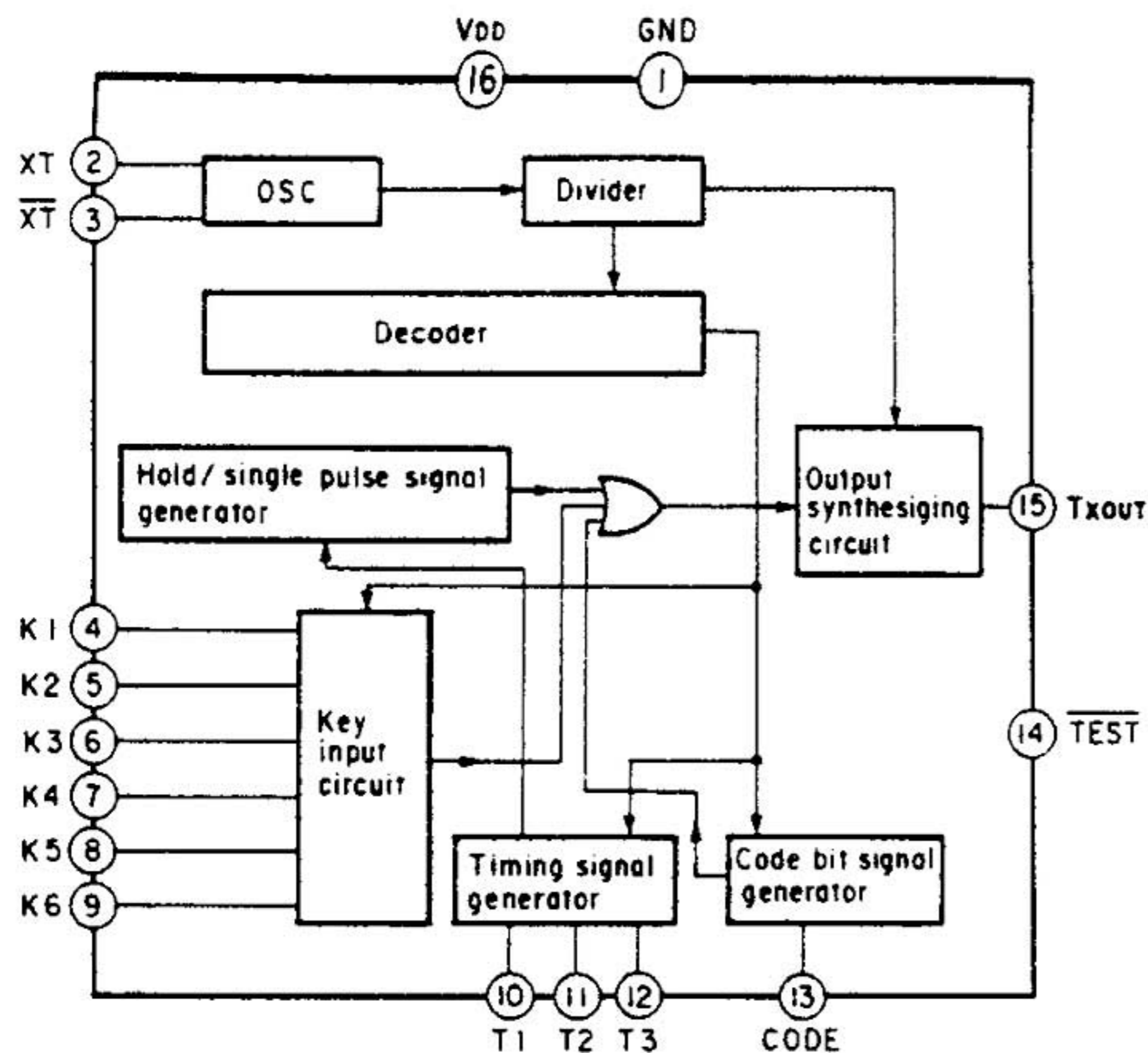

3-1. Key Functions of Remote Controller

(1) 25 Hz ~ 20 kHz Frequency Selection Keys (Key No. 1-2 ~ 4-6)

- * When GEQ setting is required to change, a required frequency band can be selected by use of these keys.
- * The selected band begins flashing.
- * Whenever these keys are depressed, GEQ is displayed automatically.
- * If no other keys are depressed for 10 sec after one of these keys is depressed, SPEANA is displayed automatically.

(2) GEQ UP/DOWN Shifting Keys (Key No. 1, 2)

- * After a frequency band has been selected by use of 25 Hz ~ 20 kHz keys, the selected band can be shifted up and down by use of these keys (± 2 dB step).
- * If these keys are kept depressed, the band is shifted up and down at a speed of 0.5 sec per step.
- * When there exists no flashing band, the band is not shifted.
- * When the band reaches the upper or lower limit, the band is not shifted.
- * When no other keys are depressed for 10 sec after these keys have been released, SPEANA is displayed automatically.

(3) MEMORY Key (Key No. 13)

- * When the present GEQ set point is required to store, this key enables memory to store the set point.
- * While memory is being enabled, MEMORY indication flashes (ON for 0.5 sec and OFF for 0.5 sec).
- * When this key is depressed, GEQ is displayed automatically.
- * When no other keys are depressed for 10 sec after this key has been depressed, SPEANA is displayed automatically and MEMORY indication goes off.
- * When another key (except this key) is depressed within 10 sec after this key has been depressed, the memory "enable" is released and MEMORY indication goes off.
- * When SW5 is at "H", MEMORY indication does not flash but stays on.
- * Even when the channel mode is in either L status or R status, both L and R mode signals are stored in the memory unit (L+R is stored all the time).

(4) M1 to M5 Preset Memory Keys (Key No. 7 ~ 11)

- * These keys are used for access to preset memory. When these keys are depressed, an indicator corresponding to depressed preset memory number comes on.
- * When this key is depressed with MEMORY kept on, the set points are written into a designated memory.
- * When this key is depressed with MEMORY kept off, the contents of designated memory can be read out.
- * When this key is depressed, GEQ is displayed automatically.
- * When sec has elapsed after this key was depressed, SPEANA is displayed automatically.

(5) Flat Key (Key No. 7)

- * This key allows GEQ presetting to be flat (25 Hz ~ 20 kHz is 0 dB).
- * When this key is depressed, GEQ is displayed automatically.
- * When 10 sec has elapsed after this key was depressed, SPEANA is displayed automatically.

(6) DISPLAY EQ (Key No. 3)

- * When this key is depressed, the display is switched to GEQ, being held until the SPEANA input key is depressed. The display mode never returns to the SPEANA display in response to key inputs other than SPEANA. The contents of display conform to the selected channel mode.

(7) DISPLAY RTA (Key No. 4)

- * When this key is depressed, the display is switched to the SPEANA display.

(8) REVERSE (Key No. 5)

- * The setting of graphic equalizer can be reversed from plus to minus or vice versa (reversed upside down with 0 dB as its center).
- * When this key is depressed, the display is switched to the GEQ display automatically.
- * The display is switched to the SPEANA display automatically, 10 secs after this key has been depressed.

(9) CHANNEL LR, L, R (Key No. 6)

- * In response to the CHANNEL MODE key inputs, the following outputs can be obtained through L terminal (Pin 25) and R terminal (Pin 24) of the microcomputer IC.

	Remote Channel Modes		
Output port	L+R	L	R
R (Pin 24)	H	L	H
L (Pin 25)	H	H	L

- * In the case of L+R mode, the equalizer display is automatically alternated for each 2 secs being switched from L channel to R channel or vice versa. However, when 10 seconds has elapsed, the spectrum analyzer is displayed by addg both the right and left channel levels.

(10) TAPE-2 OUT (Key No. 8)

- * Whenever this key is depressed, TAPE-2 terminal (Pin 12) of the microcomputer is alternately switched in level from "H" to "L" or vice versa.

(11) LINE/TAPE-1 (Key No. 10/9)

- * As listed below, in response to the remote control input keys, the following signals are outputted to the LINE OUT terminal (Pin 11) of the microcomputer.

Remote Control Input Keys		Computer Output Port LINE OUT
LINE	TAPE-1	
ON	OFF	H
OFF	ON	L
ON	ON	*

(12) EQUALIZER ON (Key No. 11)

* By the use of this key, the equalizer circuit is turned on or off. Whenever this key is depressed, the EQ ON/OFF terminal (Pin 13) of the microcomputer is alternately switched in level from "H" to "L" or vice versa.

3-2. Major Terminal Functions in Microcomputer

(1) REC OUT(1), REC OUT(2), G.E. REC(1), G.E. REC(2), DUBBING, LINE/TAPE-1, TAPE-2

* In response to each output the analog switches are controlled, so that the combinations of inputs and outputs in the set are switched. As listed below, 8 output states can be produced in combination of operations obtained through 4 input keys.

	Remote Control Input Keys				Coimputer Output Ports						
	LINE	TAPE 1	TAPE 2	G.E REC	REC OUT(1)	G.E REC(1)	DUB-BING	REC OUT(2)	G.E REC(2)	LINE/TAPE 1	TAPE 2
1	ON	OFF	OFF	OFF	H	L	L	H	L	H	L
2	OFF	ON	OFF	OFF	L	L	L	H	L	L	L
3	ON	OFF	ON	OFF	L	L	H	H	L	H	H
4	OF	ON	ON	OFF	L	L	H	H	L	L	H
5	ON	OFF	OFF	ON	L	H	L	L	H	H	L
6	OFF	ON	OFF	ON	L	L	L	L	H	L	L
7	ON	OFF	ON	ON	L	H	L	L	L	H	H
8	OFF	ON	ON	ON	L	H	L	L	L	L	H

(2) MUTE

* MUTE OUT is outputted on the basis of the following input key operation.

Input key	MUTE OUT
CHANNEL MODE INPUT Preset M1 ~ M5 INPUT FLAT INPUT REVERSE INPUT	} "H" for 0.1 sec, then to "L"
GEO ON/OFF, GEO REC ON/OFF LINE, TAPE 1, TAPE 2	

(3) DATA, CLK Output

* In response to data inputs obtained through REMOTE terminal data for controlling the analog switches and the electronic variable resistor are outputted. Refer to the LC 7520 and LC 7565 with respect to DATA CODES.

(4) P. HOLD

* PEAK HOLD is switched to ON or OFF only during the SPEANA display.

4. PARTS LOCATION & PARTS LIST

4-1. F-5170 Control Board (Stock No. 00929701)

Component Side

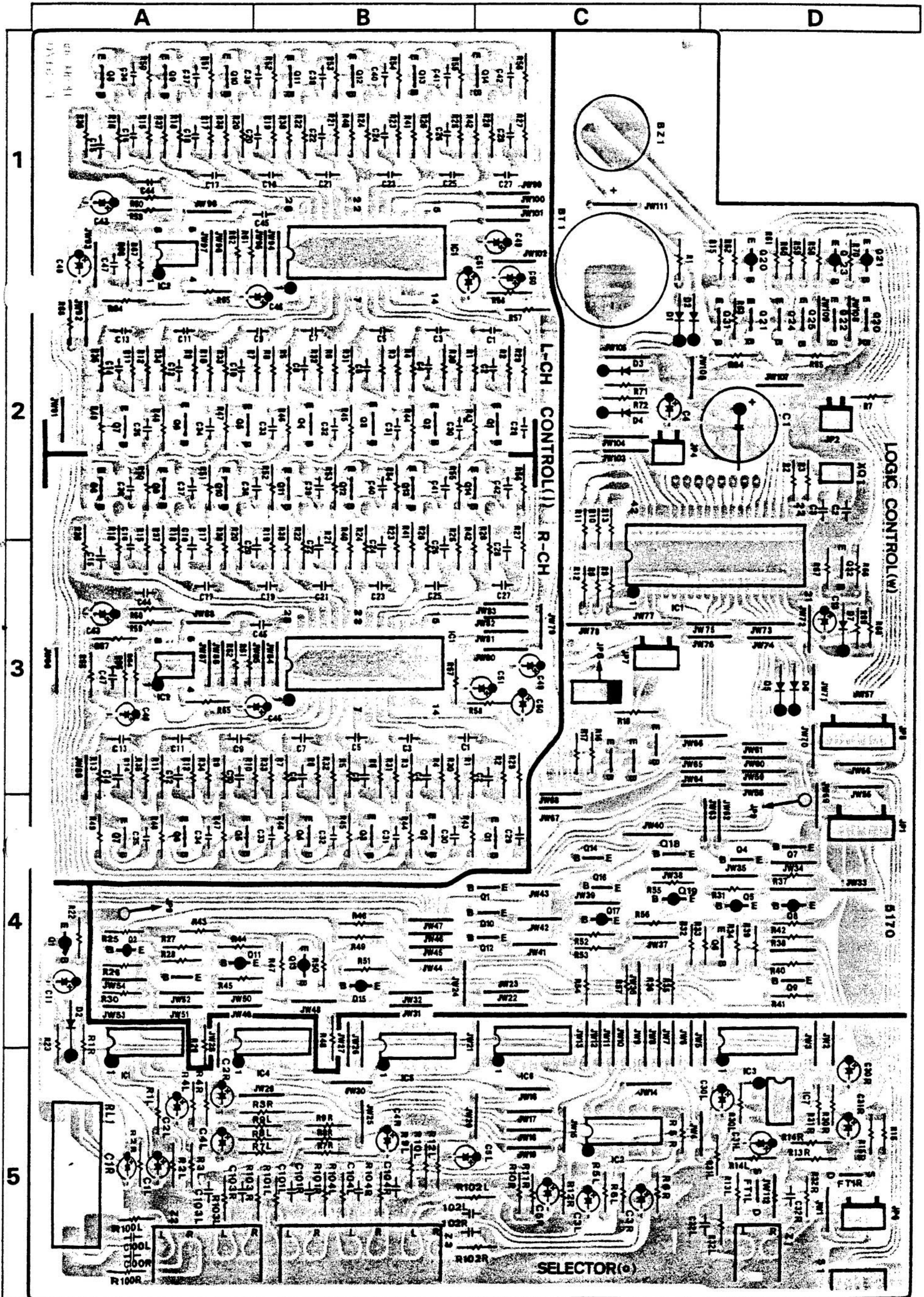

Parts List <F-5170>

Parts No.	Stock No.	Description
•Transistor		
jQ1	46367101	2SC2603
	or 46367301	2SC2458
jQ2	46367101	2SC2603
	or 46367301	2SC2458
jQ3	46367101	2SC2603
	or 46367301	2SC2458
jQ4	46367101	2SC2603
	or 46367301	2SC2458
jQ5	46367101	2SC2603
	or 46367301	2SC2458
jQ6	46367101	2SC2603
	or 46367301	2SC2458
jQ7	46367101	2SC2603
	or 46367301	2SC2458
jQ8	46367101	2SC2603
	or 46367301	2SC2458
jQ9	46367101	2SC2603
	or 46367301	2SC2458
jQ10	46367101	2SC2603
	or 46367301	2SC2458
jQ11	46367101	2SC2603
	or 46367301	2SC2458
jQ12	46367101	2SC2603
	or 46367301	2SC2458
jQ13	46367101	2SC2603
	or 46367301	2SC2458
jQ14	46367101	2SC2603
	or 46367301	2SC2458
•IC		
jIC1	48159300	LC7520
jIC2	46580100	M5218P
jC5	46532300	0.12 μ F 50V F.C.
•Transistor		
oQ1	46367001	2SA1115
	or 46367201	2SA1048
•FET		
oFT1	46643500	2SK163-K1
	or 46643501	2SK163-K2
	or 46643502	2SK163-L1
	or 46643503	2SK163-L2
	or 46643600	2SK117-O
	or 46643601	2SK117-Y
•IC		
oIC1	46255000	LC4066BH
oIC2	46255000	LC4066BH
oIC3	46255000	LC4066BH
oIC4	46255000	LC4066BH
oIC5	46255000	LC4066BH
oIC6	46255000	LC4066BH
oIC7	46580100	M5218P
•Diode		
oD2	03117700	10E-2
oS1	48127100	Slide SW., PEAK HOLD
oRL1	11504701	Relay LR2A-12B
oZ1	46363700	2P Terminal, OUTPUT
oZ2	46363800	4P Terminal, TAPE
oZ3	46363900	6P Terminal, TAPE & INPUT
•Transistor		
wQ1	46719900	DTC124ES
wQ2	46719800	DTA124ES
wQ3	46367101	2SC2603
	or 46367301	2SC2458
wQ4	46719900	DTC124ES
wQ5	46719800	DTA124ES
wQ6	46367101	2SC2603
	or 46367301	2SC2458
wQ7	46719900	DTC124ES

Parts No.	Stock No.	Description
wQ8	46719800	DTA124ES
wQ9	46367101	2SC2603
	or 46367301	2SC2458
wQ10	46719900	DTC124ES
wQ11	46719800	DTA124ES
wQ12	46719900	DTC124ES
wQ13	46719800	DTA124ES
wQ14	46719900	DTC124ES
wQ15	46719800	DTA124ES
wQ16	46719900	DTC124ES
wQ17	46719800	DTA124ES
wQ18	46719900	DTC124ES
wQ19	46719800	DTA124ES
wQ20	46719900	DTC124ES
wQ21	46719800	DTA124ES
wQ22	46719900	DTC124ES
wQ23	46719800	DTA124ES
wQ24	46719800	DTA124ES
wQ25	46719800	DTA124ES
wQ26	46719900	DTC124ES
wQ27	46719800	DTA124ES
wQ28	46719900	DTC124ES
wQ29	46719900	DTC124ES
wQ30	46719900	DTC124ES
wQ31	46367101	2SC2603
	or 46367301	2SC2458
wQ32	46367101	2SC2603
	or 46367301	2SC2458
•IC		
wIC1	48319300	LC6510C-793
wXO1	48319400	Ceramic Element KBR800H
•Diode		
wD1	03117600	1S2473T77
wD2	03117600	1S2473T77
wD3	03117600	1S2473T77
wD4	03117600	1S2473T77
wD5	03117600	1S2473T77
wD6	03117600	1S2473T77
wD7	03117600	1S2473T77
	or 46086000	1S1588TP-3
wD8	03117600	1S2473T77
	or 46086000	1S1588TP-3
wC1	46725600	3900 μ F 6.3V E.C.
wC4	46282900	0.01 μ F 50V F.C.
wBT1	46255500	Lithium Battery CR2430
wBZ1	48178400	Buzzer

4-2. F-5171 Remote Control Receiver Board

Component Side

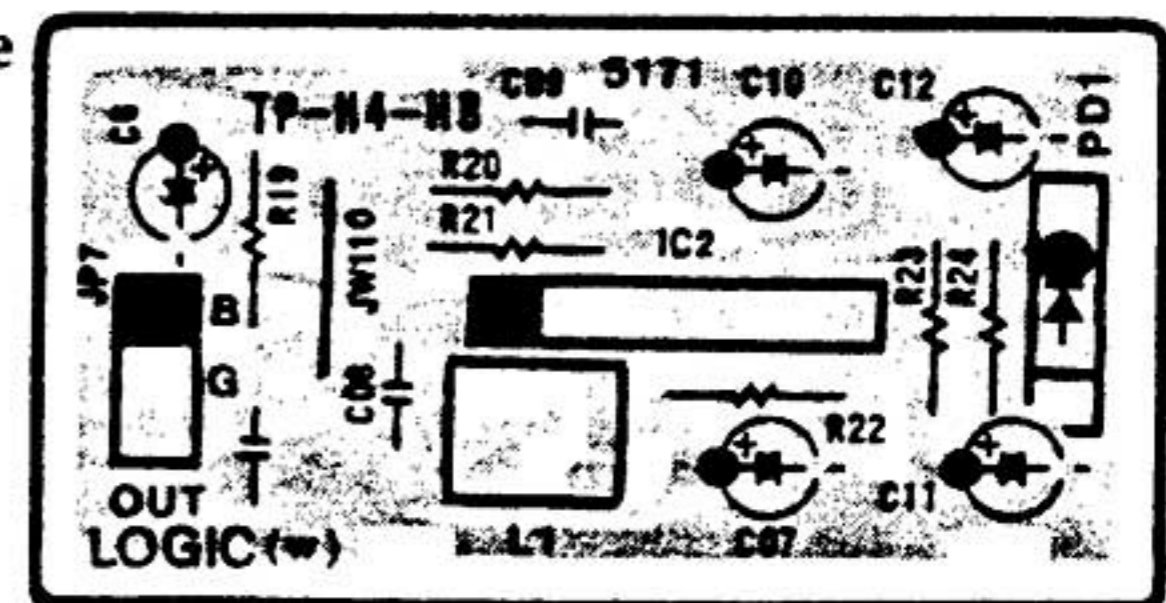

Parts List

Parts No.	Stock No.	Description
•IC		
wIC2	48159100	LA7224
wPD1	48268800	Photo Diode PD49PI
wL1	48179100	Coil (38kHz)

4-3. F-5173 Band Pass Filter Board (Stock No. 00930001)

Component Side

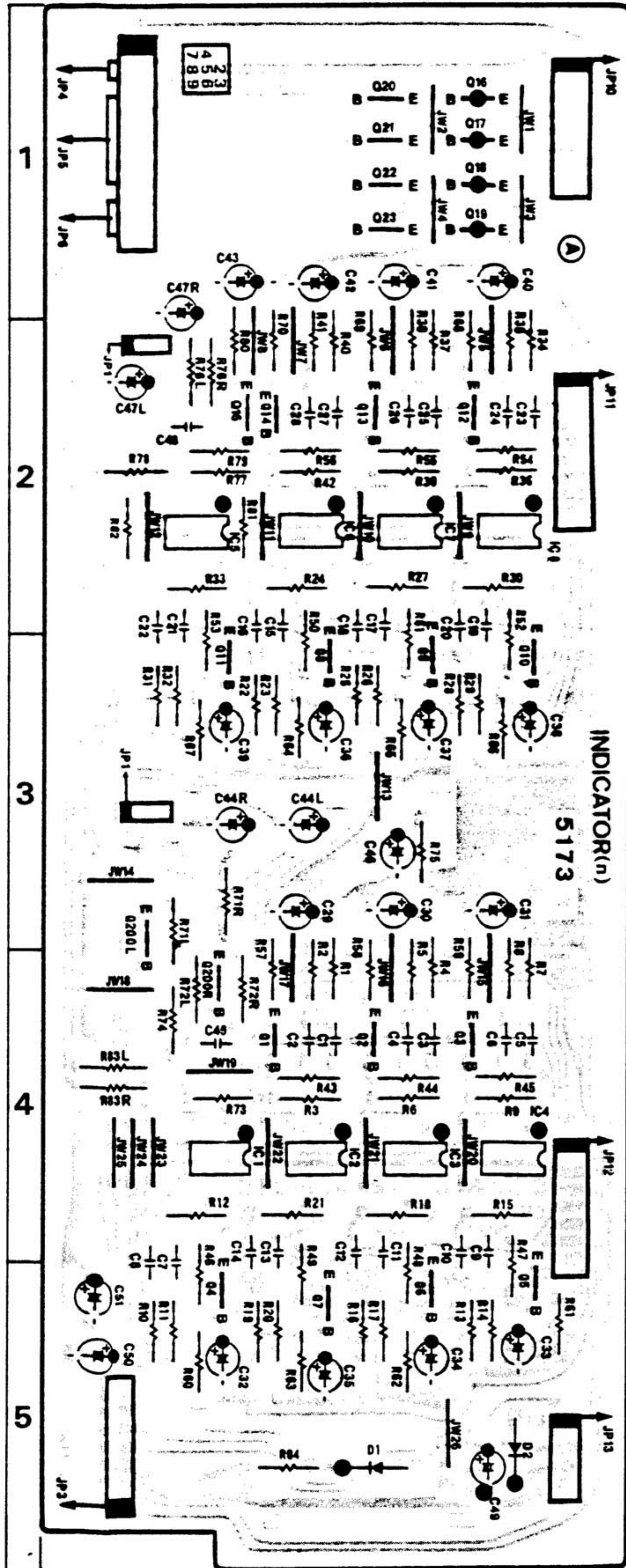

Parts List

Parts No.	Stock No.	Description
• Transistor		
nQ1	46367101	2SC2603
	or 46367301	2SC2458
nQ2	46367101	2SC2603
	or 46367301	2SC2458
nQ3	46367101	2SC2603
	or 46367301	2SC2458
nQ4	46367101	2SC2603
	or 46367301	2SC2458
nQ5	46367101	2SC2603
	or 46367301	2SC2458
nQ6	46367101	2SC2603
	or 46367301	2SC2458
nQ7	46367101	2SC2603
	or 46367301	2SC2458
nQ8	46367101	2SC2603
	or 46367301	2SC2458
nQ9	46367101	2SC2603
	or 46367301	2SC2458
nQ10	46367101	2SC2603
	or 46367301	2SC2458
nQ11	46367101	2SC2603
	or 46367301	2SC2458
nQ12	46367101	2SC2603
	or 46367301	2SC2458
nQ13	46367101	2SC2603
	or 46367301	2SC2458
nQ14	46367101	2SC2603
	or 46367301	2SC2458
nQ15	46367101	2SC2603
	or 46367301	2SC2458
nQ16	46719800	DTA124ES
nQ17	46719800	DTA124ES
nQ18	46719800	DTA124ES
nQ19	46719800	DTA124ES
nQ20	46719900	DTC124ES
nQ21	46719900	DTC124ES
nQ22	46719900	DTC124ES
nQ23	46719900	DTC124ES
nQ200	46367101	2SC2603
	or 46367301	2SC2458
• IC		
nIC1	46580100	M5218P
nIC2	46580100	M5218P
nIC3	46580100	M5218P
nIC4	46580100	M5218P
nIC5	46580100	M5218P
nIC6	46580100	M5218P
nIC7	46580100	M5218P
nIC8	46580100	M5218P
• Diode		
nD1	03117600	1S2473T77
	or 46086000	1S1588TP-3
nD2	03117600	1S2473T77
	or 46086000	1S1588TP-3

4-4. F-5174 Display Board (Stock No. 00930101)

Component Side

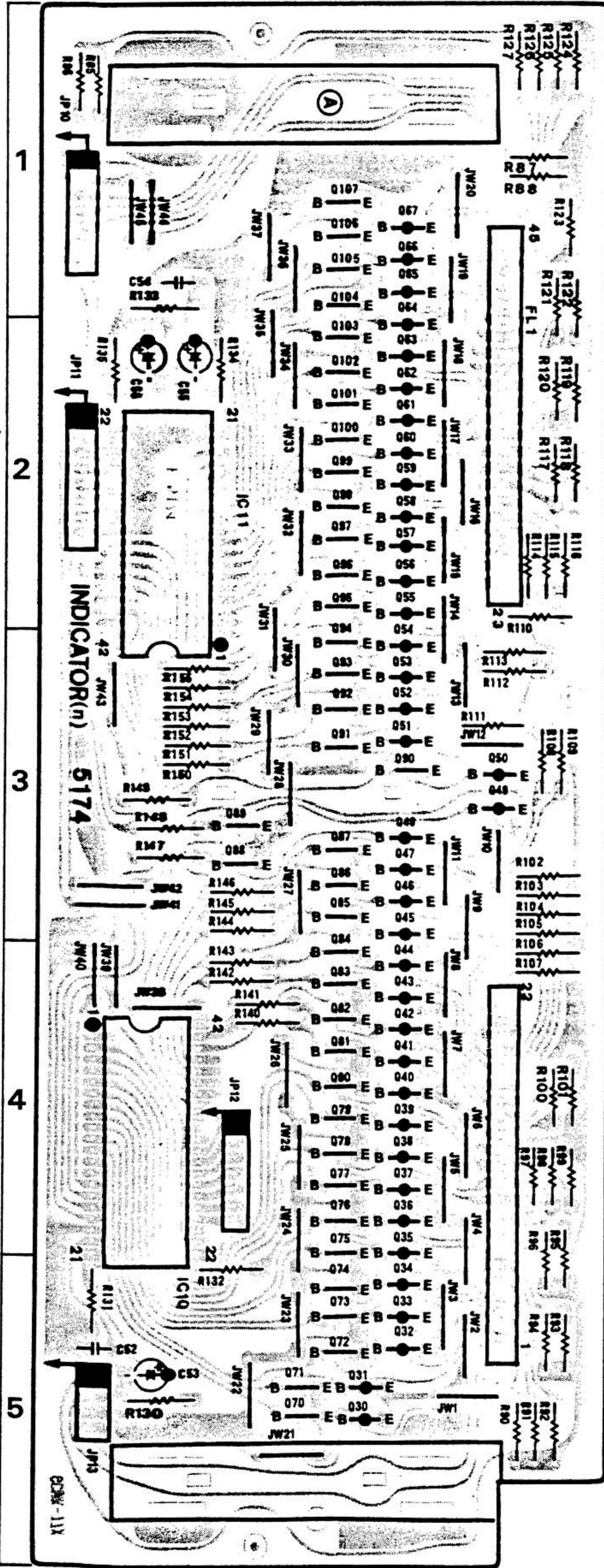

Parts List

Parts No.	Stock No.	Description
• Transistor		
nQ30	46719800	DTA124ES
nQ31	46719800	DTA124ES
nQ32	46719800	DTA124ES
nQ33	46719800	DTA124ES
nQ34	46719800	DTA124ES
nQ35	46719800	DTA124ES
nQ36	46719800	DTA124ES
nQ37	46719800	DTA124ES
nQ38	46719800	DTA124ES
nQ39	46719800	DTA124ES
nQ40	46719800	DTA124ES
nQ41	46719800	DTA124ES
nQ42	46719800	DTA124ES
nQ43	46719800	DTA124ES
nQ44	46719800	DTA124ES
nQ45	46719800	DTA124ES
nQ46	46719800	DTA124ES
nQ47	46719800	DTA124ES
nQ48	46719800	DTA124ES
nQ49	46719800	DTA124ES
nQ50	46719800	DTA124ES
nQ51	46719800	DTA124ES
nQ52	46719800	DTA124ES
nQ53	46719800	DTA124ES
nQ54	46719800	DTA124ES
nQ55	46719800	DTA124ES
nQ56	46719800	DTA124ES
nQ57	46719800	DTA124ES
nQ58	46719800	DTA124ES
nQ59	46719800	DTA124ES
nQ60	46719800	DTA124ES
nQ61	46719800	DTA124ES
nQ62	46719800	DTA124ES
nQ63	46719800	DTA124ES
nQ64	46719800	DTA124ES
nQ65	46719800	DTA124ES
nQ66	46719800	DTA124ES
nQ67	46719800	DTA124ES
nQ70	46719900	DTC124ES
nQ71	46719900	DTC124ES
nQ72	46719900	DTC124ES
nQ73	46719900	DTC124ES
nQ74	46719900	DTC124ES
nQ75	46719900	DTC124ES
nQ76	46719900	DTC124ES
nQ77	46719900	DTC124ES
nQ78	46719900	DTC124ES
nQ79	46719900	DTC124ES
nQ80	46719900	DTC124ES
nQ81	46719900	DTC124ES
nQ82	46719900	DTC124ES
nQ83	46719900	DTC124ES
nQ84	46719900	DTC124ES
nQ85	46719900	DTC124ES
nQ86	46719900	DTC124ES
nQ87	46719900	DTC124ES
nQ88	46719900	DTC124ES
nQ89	46719900	DTC124ES
nQ90	46719900	DTC124ES
nQ91	46719900	DTC124ES
nQ92	46719900	DTC124ES
nQ93	46719900	DTC124ES
nQ94	46719900	DTC124ES
nQ95	46719900	DTC124ES
nQ96	46719900	DTC124ES
nQ97	46719900	DTC124ES
nQ98	46719900	DTC124ES
nQ99	46719900	DTC124ES
nQ100	46719900	DTC124ES
nQ101	46719900	DTC124ES
nQ102	46719900	DTC124ES
nQ103	46719900	DTC124ES
nQ104	46719900	DTC124ES
nQ105	46719900	DTC124ES

Parts List <F-5174>

Parts No.	Stock No.	Description
nQ106	46719900	DTC124ES
nQ107	46719900	DTC124ES
•IC		
nIC10	48159400	LC7565
nIC11	48159400	LC7565
nFL1	48319500	FL. Display Tube CP1061GR
nC53	48152100	47 μ F 6.3V E.C.
nC55	48152100	47 μ F 6.3V E.C.

4-5. F-5172 Indicator Board

Component Side

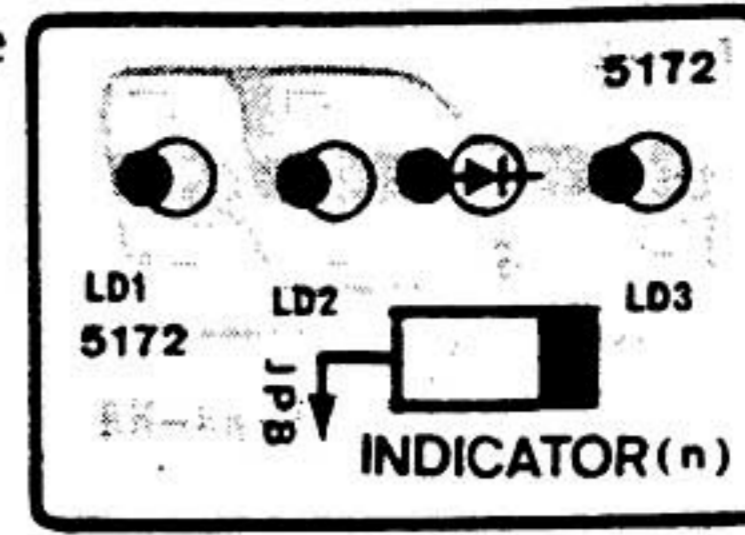

Parts List

Parts No.	Stock No.	Description
•LED		
nLD1	46176900	TLS-123, LINE
nLD2	46176900	TLS-123, TAPE 1
nLD3	46176900	TLS-123, TAPE 2

4-6. F-5169 Power Supply Board (Stock No. 00929601 = XX, UL, EU, UK/Stock No. 00929603 = CSA)

Component Side

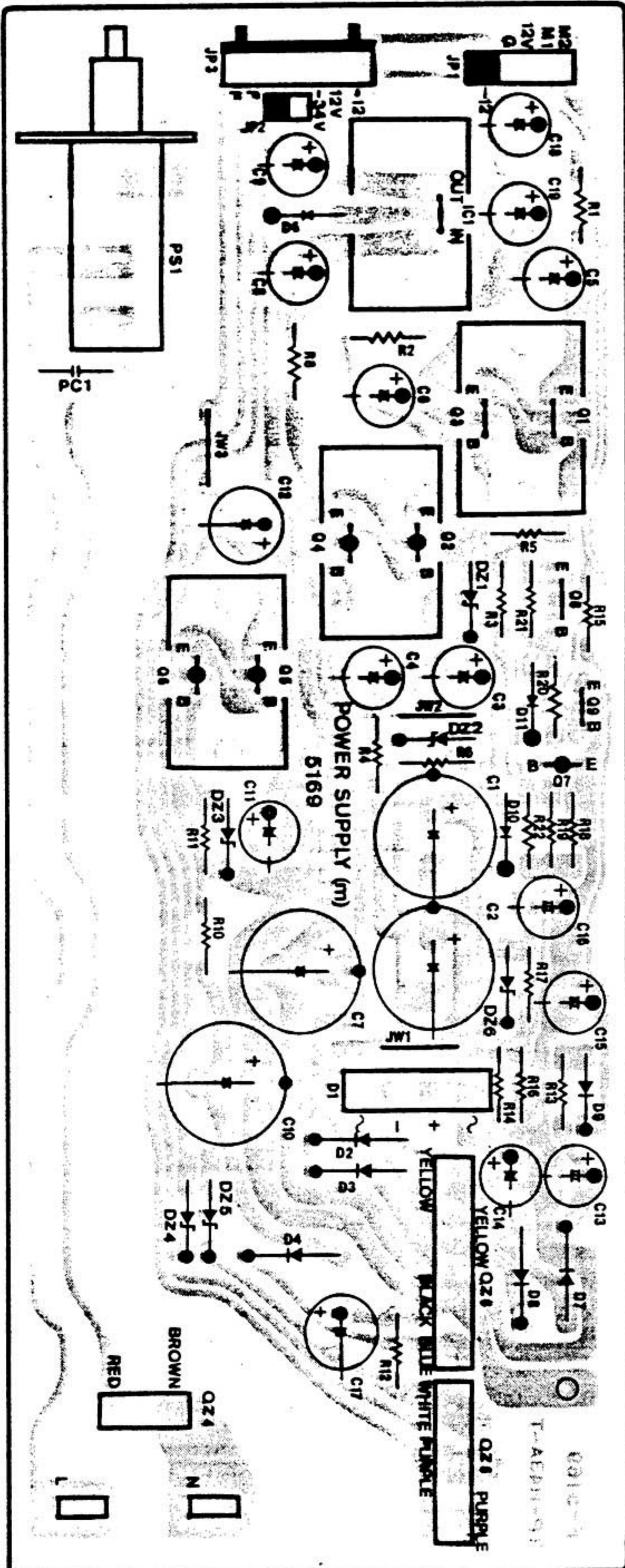

Parts List

Parts No.	Stock No.	Description
•Transistor		
Δ mQ1	03083901	2SD313AL
Δ	or 46546701	2SD880
Δ	or 48073601	2SD1061
mQ2	48063301	2SB507
	or 48064601	2SB825
mQ3	46367101	2SC2603
	or 46367301	2SC2458
Δ mQ4	46367001	2SA1115
Δ	or 46367201	2SA1048
Δ mQ5	48063301	2SB507
Δ	or 48064601	2SB825
mQ6	46367001	2SA1115
	or 46367201	2SA1048
mQ7	46367001	2SA1115
	or 46367201	2SA1048
mQ8	46367101	2SC2603
	or 46367301	2SC2458
mQ9	46367101	2SC2603
	or 46367301	2SC2458
•IC		
Δ mIC1	46144200	NJM78M05A
•Diode		
Δ mD1	03117000	RB152-LFF
Δ mD2	03117700	10E-2
Δ mD3	03117700	10E-2
Δ mD4	03117700	10E-2
mD6	03117600	1S2473T77
Δ mD7	03117700	10E-2
Δ mD8	03117700	10E-2
mD9	03117600	1S2473T77
	or 46086000	1S1588TP-3
mD10	03117600	1S2473T77
	or 46086000	1S1588TP-3
mD11	03117600	1S2473T77
	or 46086000	1S1588TP-3
•Zener Diode		
mDZ1	46113900	05Z12-Y
mDZ2	46113900	05Z12-Y
mDZ3	46116900	05Z33-Y
mDZ4	03167500	RD3.3F-B
mDZ5	03167500	RD3.3F-B
mDZ6	46111800	05Z6.2-Y
Δ pC1	46425800	0.01 μ F 400V C.C.
Δ	or 46943200	0.01 μ F 400V C.C.
Δ pS1	48065200	Push SW., Power (CSA)
Δ	46413900	Push SW., Power (XX,UL,EU,BS)
Δ mR3	00135800	4.7 Ω 1/2W N.I.R.
Δ mR4	00135800	4.7 Ω 1/2W N.I.R.
Δ mR8	00134100	33 Ω 1W N.I.R.
Δ mR10	00135800	4.7 Ω 1/2W N.I.R.
Δ mR13	00133000	220 Ω 1/2W N.I.R.

5. OTHER PARTS

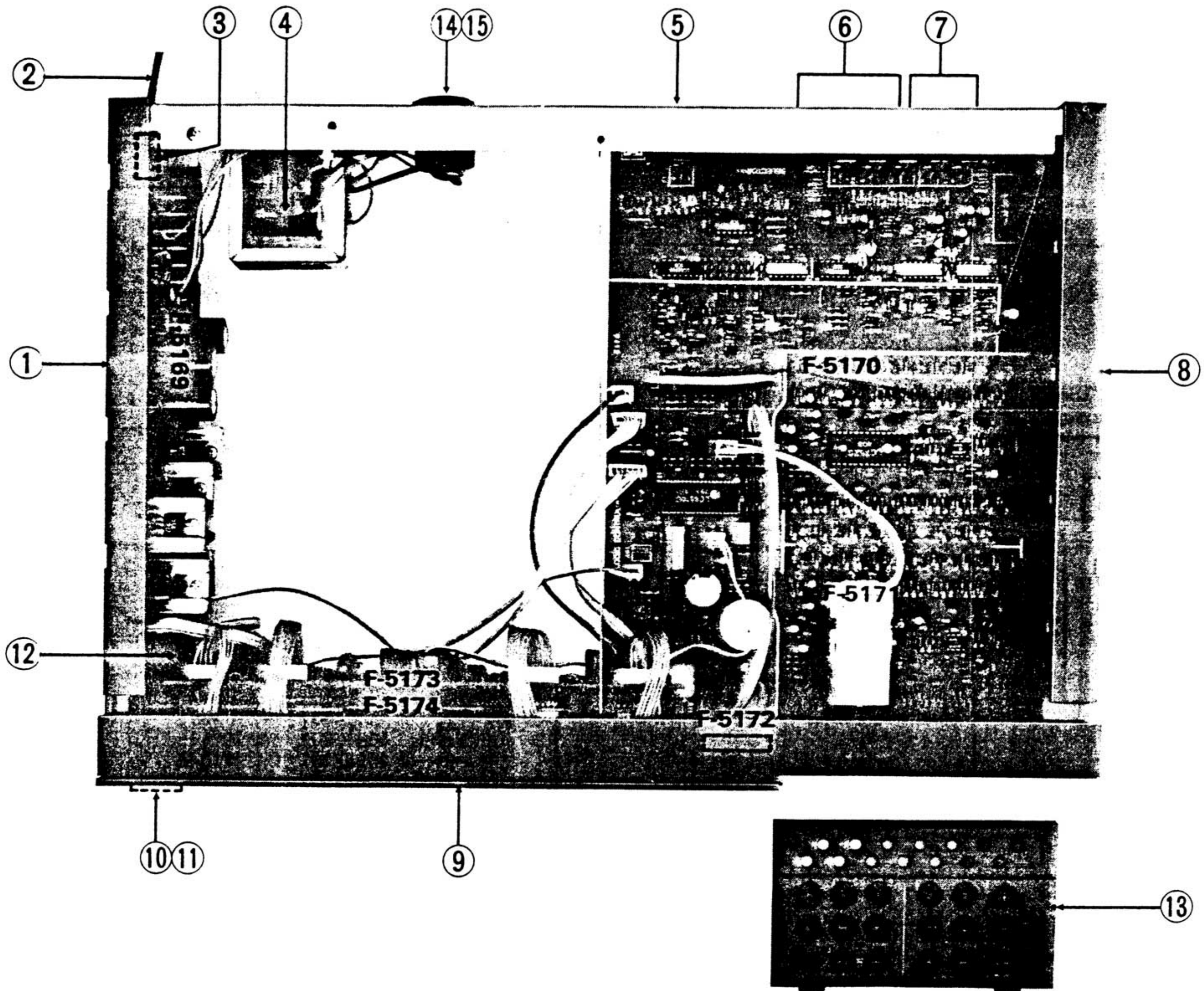

Parts List

Parts No.	Stock No.	Description
1	47608900	Left Side Panel
△ 2	38004700	Power Supply Cord (XX,UL,CSA)
△	38004500	Power Supply Cord (EU)
△	38004300	Power Supply Cord (BS)
3	47157300	AC Cord Cover
△ 4	15022409	Power Transformer with Voltage Selector Socket (XX)
△	15022402	Power Transformer (UL,CSA)
△	15022405	Power Transformer (EU,BS)
5	46363700	2P Output Terminal
6	46363800	4P Tape Terminal
7	46363900	6P Tape Terminal
8	47609000	Right Side Panel
9	27046700	Front Panel Ass'y
10	27040900	Knob, Power Switch
△ 11	46413900	Push SW., POWER (XX,UL,EU,BS)
△	48065200	Push SW., POWER (CSA)
12	47705700	Joint Shaft, Power SW.
13	48314700	Remote Controller Unit, RS-880
△ 14	48175200	Voltage Selector Plug (XX)
△ 15	07204700	Voltage Selector Switch (EU,BS)
	47301000	Bonnet

6. SCHEMATIC DIAGRAM

6-1. Signal Switching & Graphic Equalizer Section

*Design and specifications subject to change without notice for improvement.
 *La présentation et les spécifications sont susceptibles d'être modifiées sans préavis par suites d'améliorations éventuelles.
 *Änderungen, die dem technischen Fortschritt dienen, bleiben vorbehalten.



RESISTORS
 Are in ohms, 1/4 W or 1/2 W, ±5% Tolerance
 Unless Otherwise Noted. R: 10K, M: 1MΩ

CAPACITORS
 Are in pF, Unless Otherwise Noted. P: pF

Electrolytic Capacitor
 Capacitance (μF) / Volt (V)

TOLERANCE

Each D.C. Voltage shows the nominal value in volts at no input signal!

Each D.C. Voltage measured by the instruments described below shows the nominal value in volts at 33 1/3 rpm Measuring Instruments.
 Volt Meter
 Oscilloscope

Safety part.
 Use only replacement parts recommended by the manufacturer.

SYMBOL
 ▲ Ceramic
 ▽ Barrier Layer Capacitor
 ● Film
 □ Non-Inflammable Resistor

SYMBOL OF FUNCTION
 (j) CONTROL
 (m) POWER SUPPLY
 (n) INDICATOR
 (o) SELECTOR
 (w) LOGIC

— Signal Line
 - - - Remote Signal Line

6-2. Spectrum Analyzer & Power Supply Section

*Design and specifications subject to change without notice for improvement.
 *La présentation et les spécifications sont susceptibles d'être modifiées sans préavis par suites d'améliorations éventuelles.
 *Änderungen, die dem technischen Fortschritt dienen, bleiben vorbehalten.



7. PACKING LIST

Parts No.	Stock No.	Description
1	47859100	Vinyl Cover
2	27047000	Styrofoam Packing (Left Side)
3	27047100	Styrofoam Packing (Right Side)
4	27046800	Carton Case

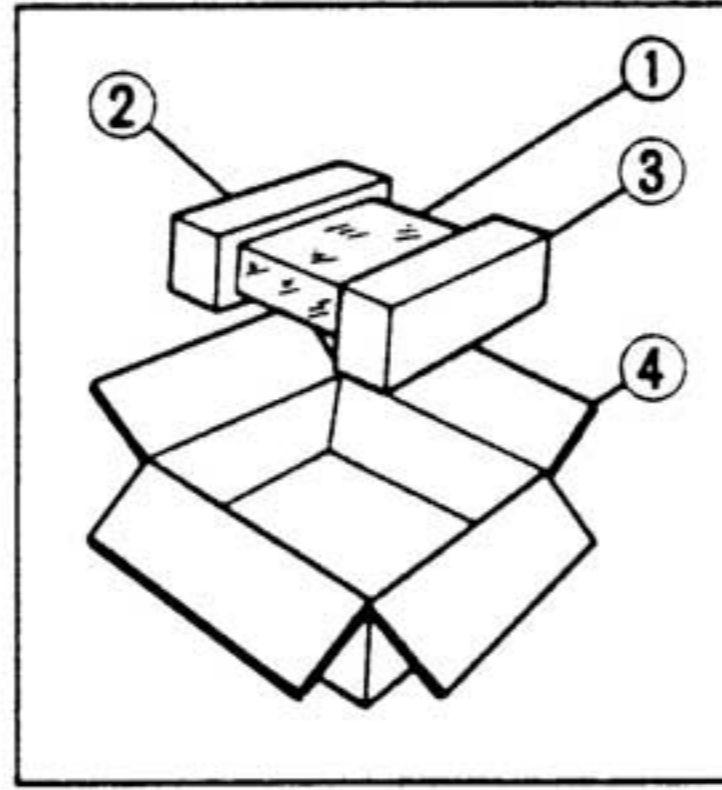

8. ACCESSORY LIST

	Stock No.	Description
	07193400	Pin Plug Cord
or	38103300	Pin Plug Cord
	46988700	Operating Instructions (*E•F•S)
	46994300	Operating Instructions (*G•I•S)

***Note:**

E•F•S: English•French and Spanish Version
G•I•S: German•Italian and Swedish Version