

1. BLOCK DIAGRAM

1) SR-737/SR-7090

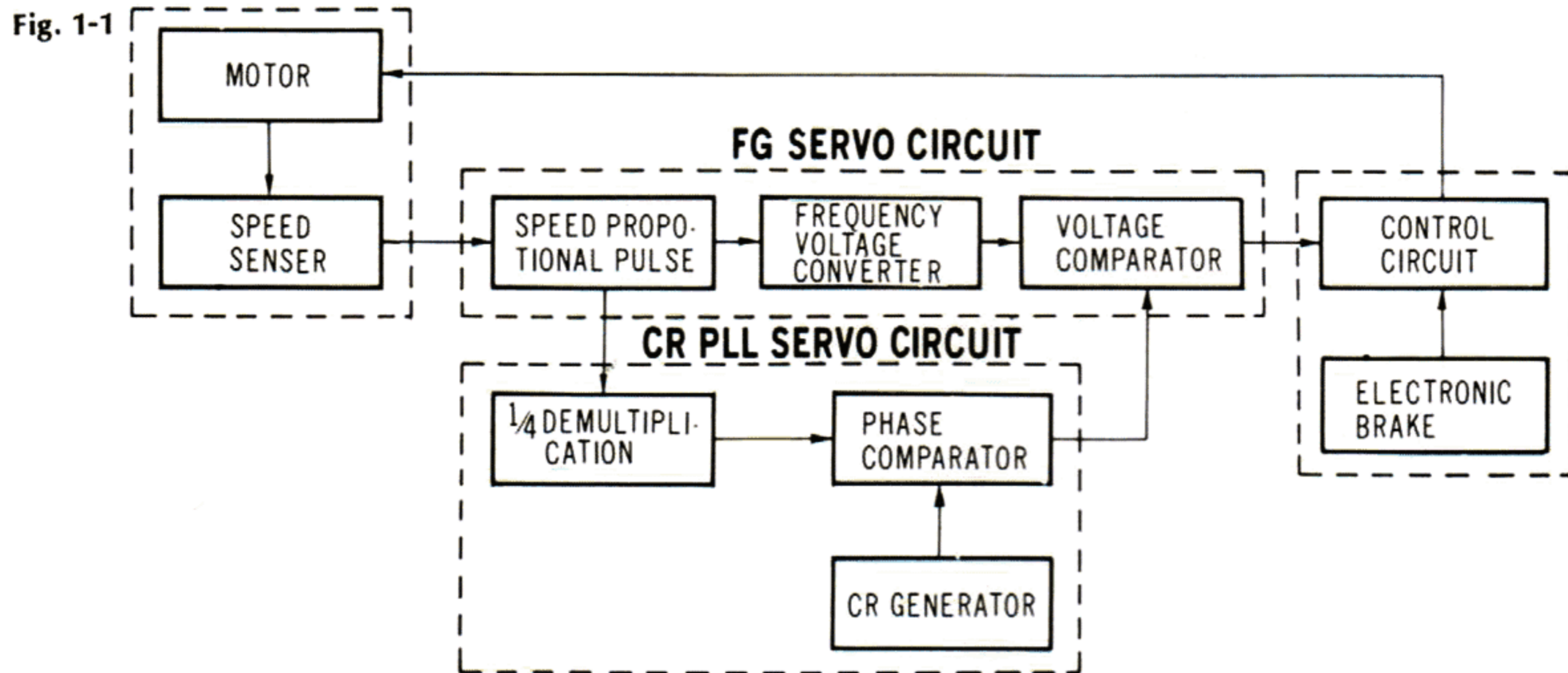
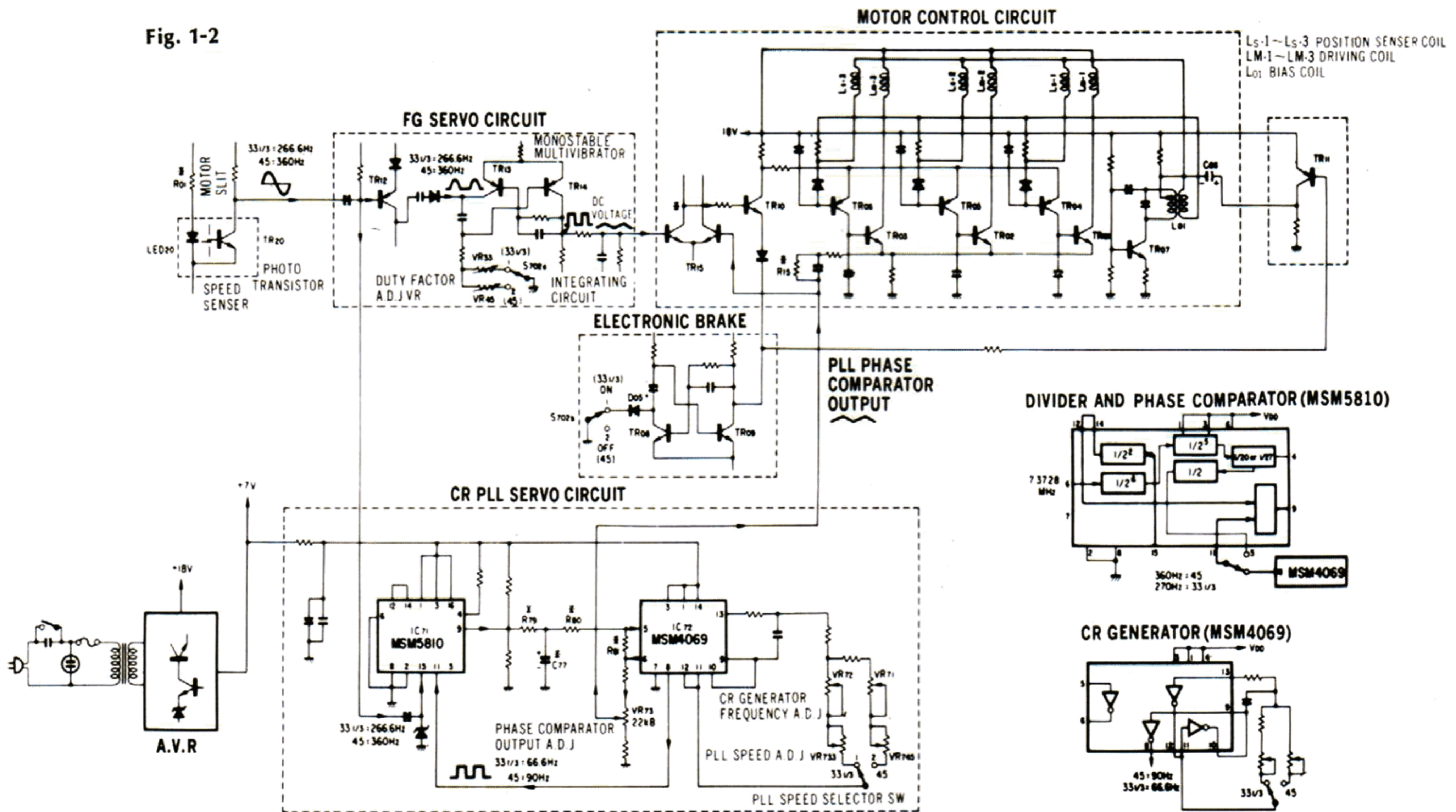

Fig. 1-2



SR-737, SR-7090 Main Circuit

The electronic circuitry in this set is two servo circuits and a motor control circuit.

The servo circuit employs the PLL servo system and the speed control system (frequency-generator servo) together.

This set employs both the F-G servo system and PLL servo system by which rotation fluctuation is always locked in the reference signal.

2) SR-535/SR-5090

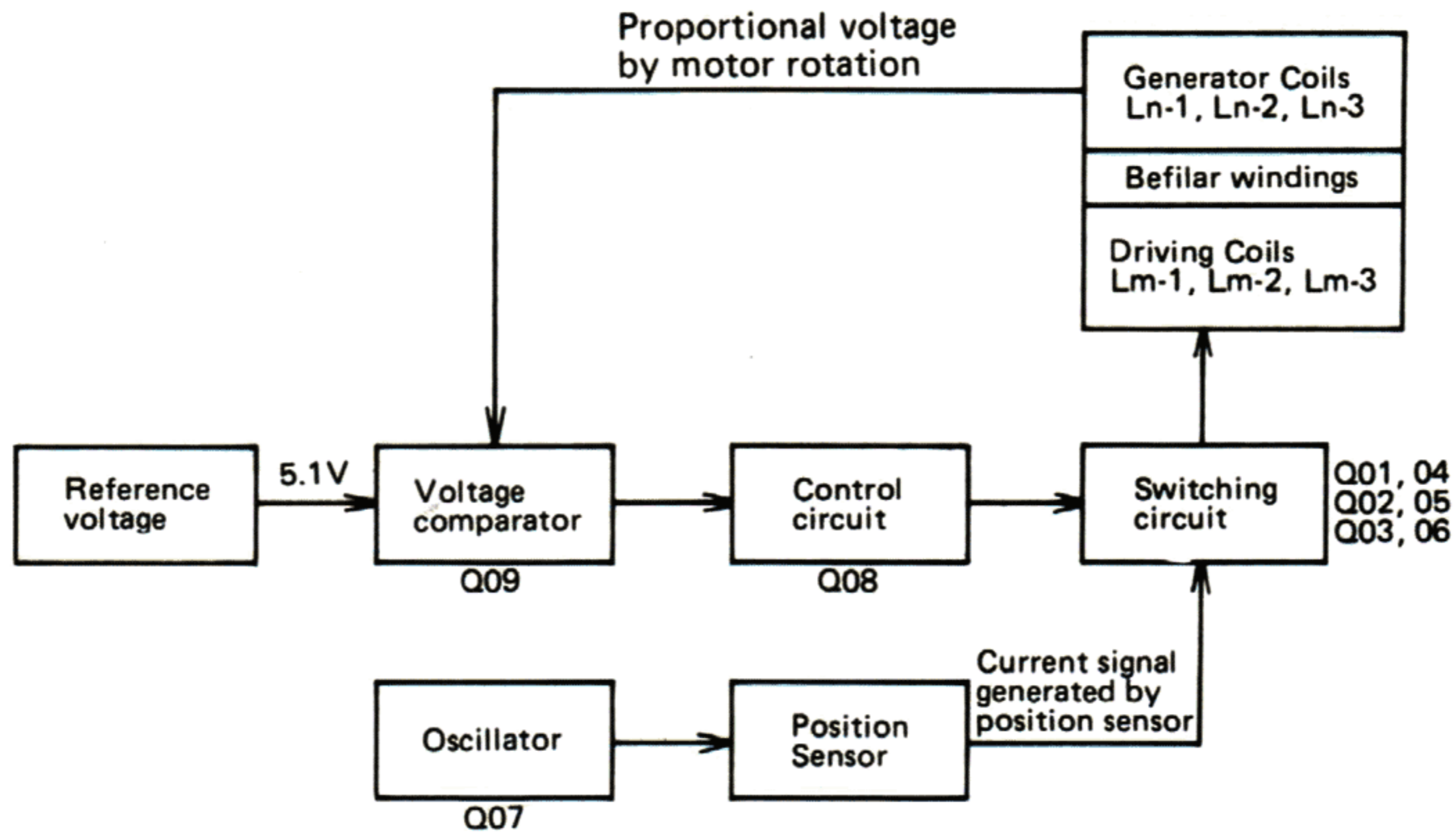

2. OPERATIONS OF ELECTRIC CIRCUIT

A. SR-535/SR-5090

D.D. Motor of this direct-drive player system is DC brushless servo motor having 20-pole on interior surface of the rotor magnet and 30 slots for winding stator coils, which ensure the performance for extremely less wow-flutter and over-load fluctuation. Namely, driving operations of this D.D. Motor connected with V.G (Voltage Generator) servo circuit board are as follows.

Generator coils, Ln-1, Ln-2 and Ln-3 oscillate voltage proportional by rotation speed of the motor. Voltage comparator compares the voltage induced by rotation speed with reference voltage, 5.1 volts, from printed circuit board, S-0015. Control circuit, Q08, restricts current of driving coils by control signal occurred in the voltage comparator, Q09.

When this current flows by turn into one of three driving coils, Lm-1, Lm-2 and Lm-3, the motor rotation speed varies to the current proportionally. And, the induced voltage of three generator coils change proportionally by changing motor rotation speed. In other words, voltage comparator compares the voltage proportional by rotation speed induced in generator coils with reference voltage, 5.1V, as a result, control voltage appears at one of collectors of Q09. This control voltage is provided for the purpose of obtaining an accurate rotation speed of the motor free from load-fluctuation of motor revolution.

As mentioned above, the motor is brushless outer rotor motor and this outer rotor on interior surface is magnetized in order of N-S-N-S poles regularly. The induced current by the rotor-turn flows into one of driving coils. Namely, very weak high-frequency signal, 83 kHz generated by oscillator coil, L01, and capacitor, C07, adds to three position sensors. This sensor detects the turning angle of rotor, and it generates current signal corresponding to rotation angle which operates for switching circuits, Q01, Q02, Q03, Q04, Q05 & Q06, then it flows into Lm-1, Lm-2 and Lm-3 by turn, resultly, the current drives turntable (platter) to obtain an accurate normal speed rotation.

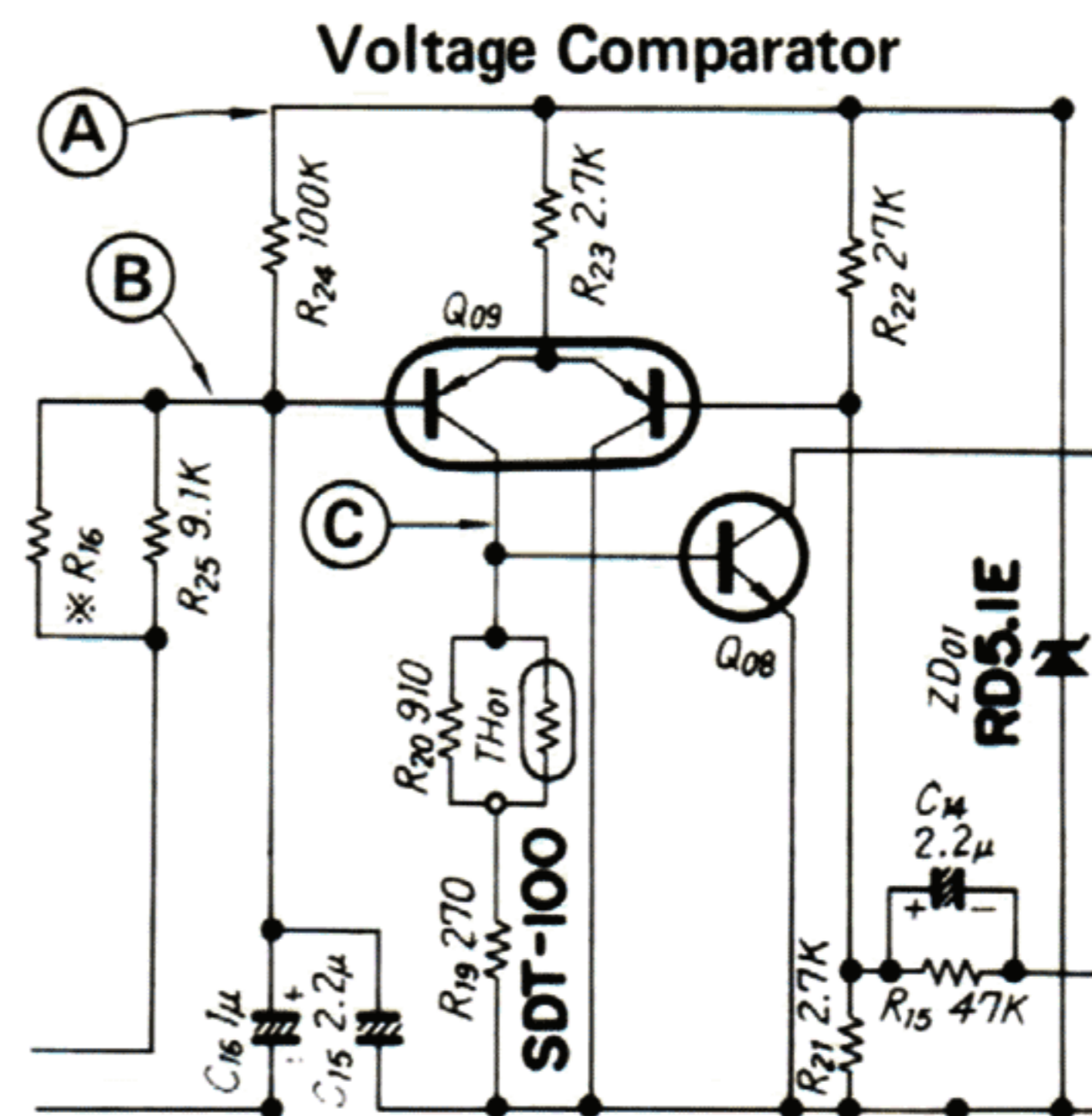

- (A) : Reference voltage 5.1V
- (B) : Proportional voltage from generator coils by rotation speed of motor
- (C) : Control voltage

1) The Function and Operation of MSM5810 (Fig. 2-1)

CR. PLL

1. From CR generator in MSM4069, the reference signal enters into the pin No. 11 of MSM5810.
2. A signal from speed sensor is supplied to pin No. 15 and after divided into 1/2, the signal is supplied to phase comparator.
3. In quartz PLL, the revolution speed is locked by its generating frequency; however, in CR PLL, pitch is controllable by altering its generating frequency.

2) Frequency-voltage Converter Circuit (Fig. 2-2)

The frequency-voltage converter circuit is composed of a mono-stable multivibrator by TR13, TR14.

When trigger pulse detected by speed sensor is supplied to TR13, pulses which width are defined by time constant CR20, R22, R68, and VR33 (R22, VR45), appears at the collector of TR14 as the same number as input trigger pulses.

The volume of VR33 and VR45 are for duty factor adjustment to determine the "t", the pulse width.

With fluctuation of turntable revolution speed, the trigger pulse frequency occurred in a unit period varies.

As the width "t" of the pulse is defined by above mentioned C, R, it would not change but term "T" in which the trigger occurs, would change.

Therefore, at the output of the next stage, integrating circuit, the proportioned D.C output to the trigger pulse frequency is obtained.

● Duty Factor

When a pulse of width "t" is occurring in a certain term "T", t/T is so called DUTY FACTOR.

$$\text{DUTY FACTOR (D)} = \frac{\text{PULSE WIDTH (t)}}{\text{TERM (T)}}$$

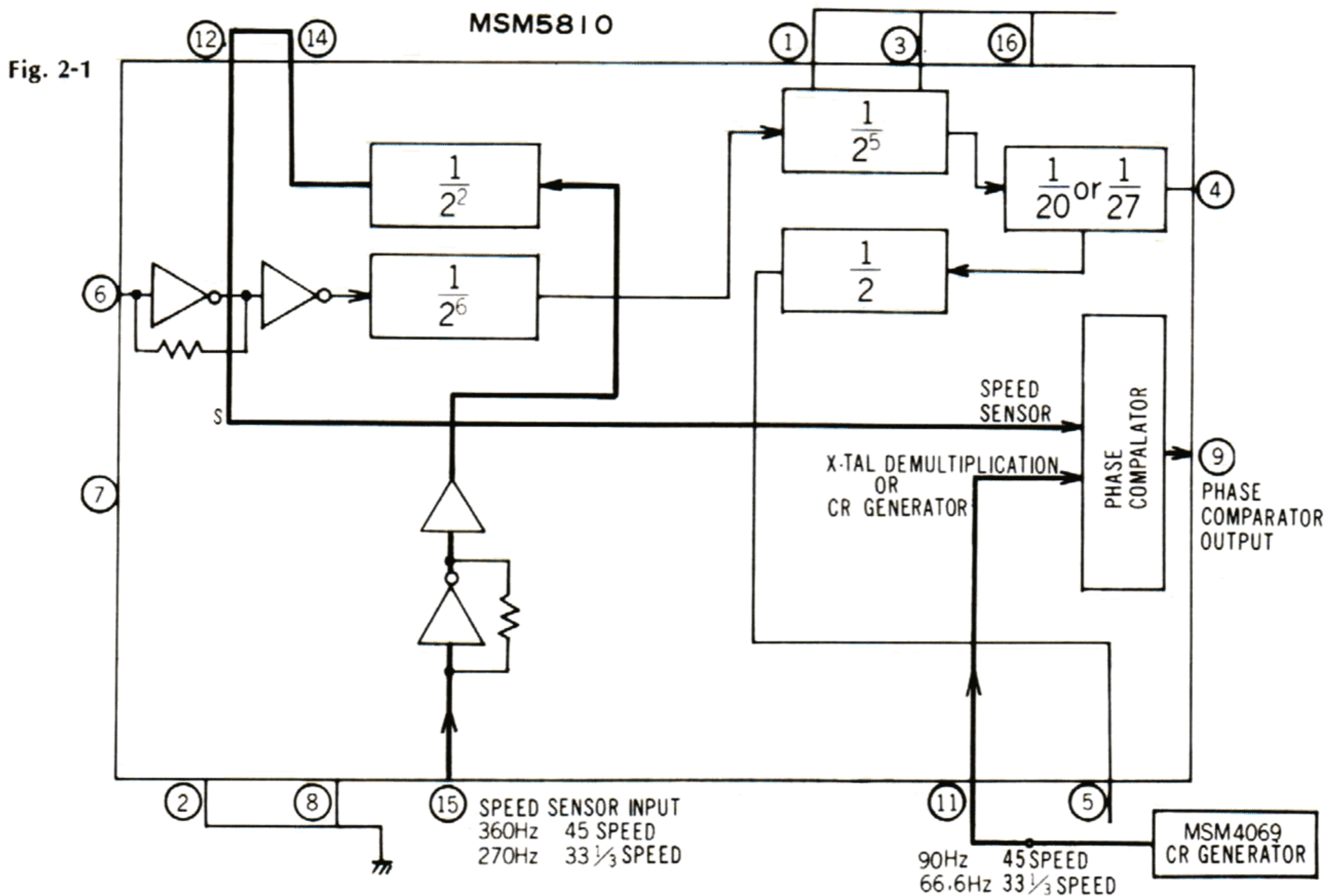

3) Electronic Brake (Fig. 2-3)

Configuration

As turntables (platters) which are employed in direct drive system players, have great inertial moment, it requires certain time to settle the rotation when shifting the revolution speed from 45 rpm to 33-1/3 rpm.

To avoid above phenomenon, this model is developed to have Electronic Brake. The torque needed for the brake is obtained by reversing the revolving direction of motor to eliminate the capacitor C06 electrically from high frequency oscillator in the motor control circuit and by switching off the speed control transistor (TR10) to omit the servo control that the reverse revolution torque is increased.

In fact, turntable platter would not begin reverse turn because of the inertial moment and time length of braking.

The circuit to eliminate the capacitor C06 electrically and to turn off the speed control transistor is monostable multivibrator and selector switch as shown in Fig. 2-3.

Operation

A circuit including TR08 and TR09 is a monostable multivibrator and usually its operation is in stable state with TR09 being ON. When TR09 is ON, TR10 functions normally and TR11 is ON. C06 and R20 are parallelly connected and functioning to TR11. When revolution speed is shifted from 45 rpm to 33-1/3 rpm, namely S702 is switched from 2 to 1, a minus trigger is supplied to monostable multivibrator.

At the same time, plus pulse defined by R13 and C11 is generated at the collector of TR09. By this pulse, the emitter voltage of TR10 is increased so that TR10 becomes not to function as speed control and the servo system does not function.

Since this pulse is supplied to the base of TR11 simultaneously, TR11 turns off and makes C06 not function completely.

When C06 is eliminated electrically, both reverse turn and torque increase by cutting off the servo system occur at once. Consequently, the brake functions only while the pulse is generated.

Reverse Revolution

At normal revolution, the direction is defined by relation between position sensor coil and magnet, position sensor coil and driving coil, and others. One of 3 position sensor coils functions successively and individually which turns on the switching transistors connected to position sensor coil to function driving coils.

At reverse revolution, a signal wave having $90^\circ \sim 180^\circ$ of phase difference against standard wave is mixed to preceding standard wave by eliminating C06 electrically. Then the mixed wave is supplied to switching transistors.

Above function breaks the electrical balance of position sensor coils and its function becomes opposite; therefore, the position sensor coil which is normally ON turns OFF and other coils become ON. As a result, the opposite revolution torque for brake is obtained.

Fig. 2-2 MONOSTABLE MULTIVIBRATOR CIRCUIT

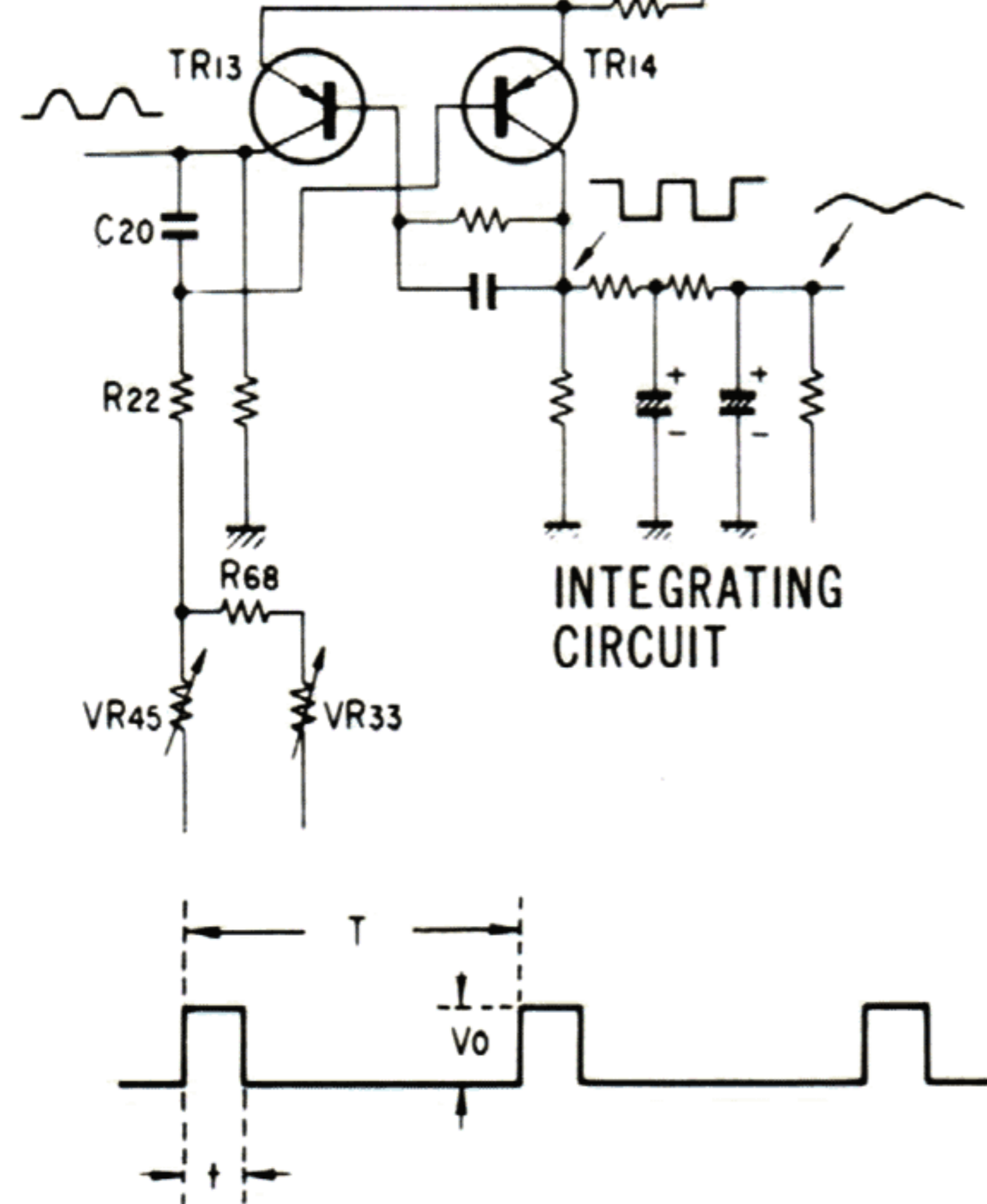
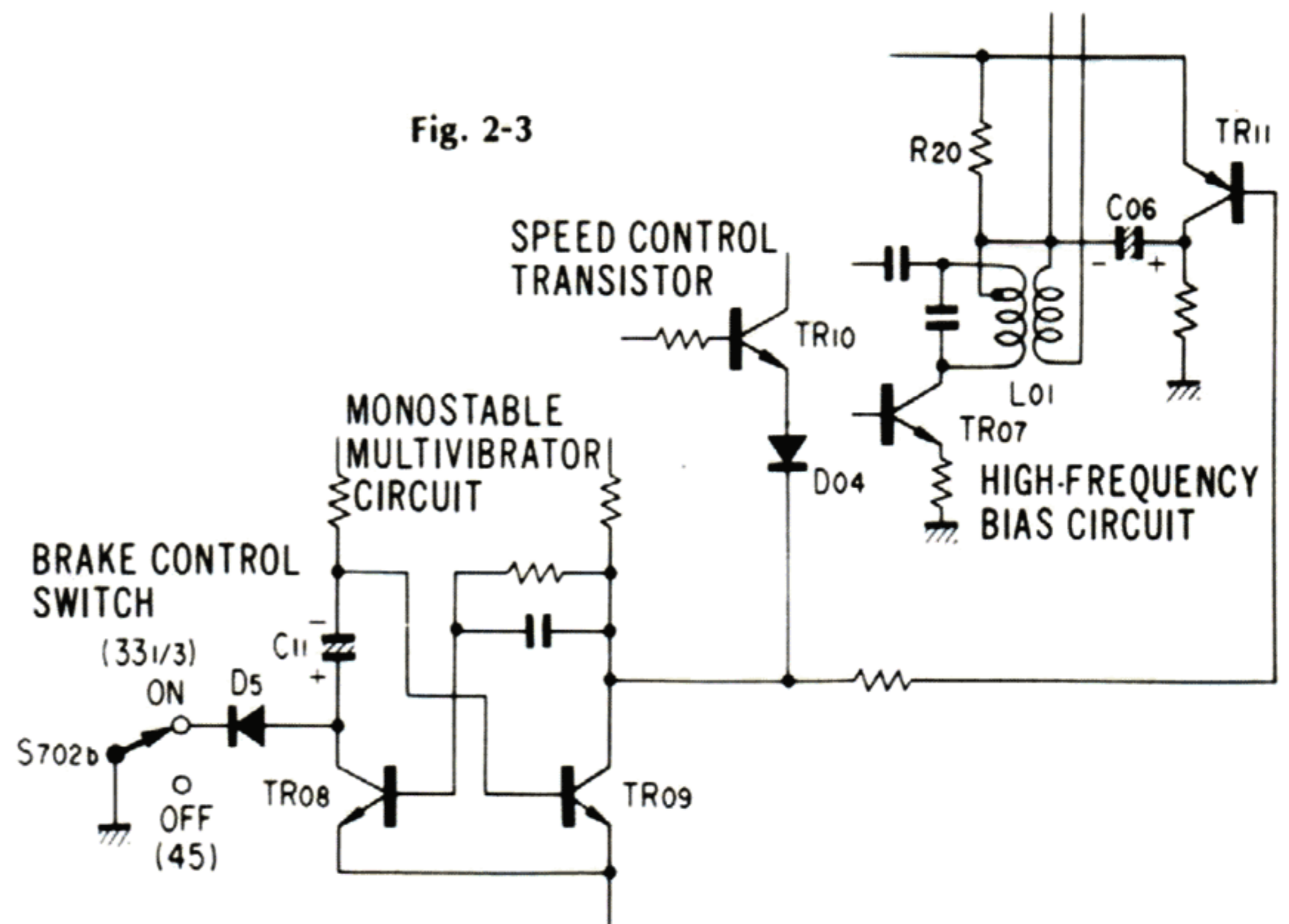

Fig. 2-3



3. OPERATIONS OF AUTO MECHANISM

1) AUTO-RETURN MOVEMENT (Fig. 3-2)

After a record having been played and when the stylus proceeding to the lead-out groove, as to model SR-535/SR-5090 the L.O. adjusting plate under the tone arm pushes the sensor lever directly, and as to model SR-737/SR-7090, the L.O. adjusting plate under the tone arm passes through over the Cds sensor plate, and by this action, the sensor obtains a position detecting signal which makes sensor AMP and Plunger function, and then the sensor lever is pushed.

Movement of the crutch makes both the T.T. gear and the main gear engage each other and then the main gear rotates by one revolution.

The first half revolution of the main gear pushes the driving arm outward and also the swing disk rotates in its return direction. At this moment, two rubber rings mounted on the chucking arm end of the swing disk catch the T.A. driving board under the tone arm by the operation of a guide hole of the mechanical chassis.

As a result of this, the tone arm moves in the same direction as the swing disk and is replaced on the arm rest owing to this auto-return movement.

Just before the reverse revolution of the swing disk, the release cam (triangle shape) makes release the catching action of the T.A. driving board operated by the two rubber rings mounted on the chucking arm end of the swing disk.

Therefore, at the time of the reverse revolution of the swing disk (in the lead-in direction) depending on the second half of the main gear revolution, the controlling of the tone arm is completely released. At the same time, just before completion of the swing disk movement, the claw lever moves outwards and the claw lever hooks the auto switch lever to move the switch-fixing board, so that the power supply switch is turned off.

2) AUTO-START MOVEMENT (Fig. 3-3)

When the cuing knob is turned to the Auto-Start position, the manual check lever is pulled and also the manual cam is moved through the link rod (2), and then the start lever and the sensor lever are both pushed.

Hence, the crutch moves and engages with the T.T. gear of the rotating center shaft. Further, the pushing-out of the start lever moves the auto switch lever and makes the switch-fixing board keep apart from the driving arm to turn on the power switch, as a result, turntable (platter) begins rotating.

The first half revolution of the main gear pushes the driving arm and then the swing disk rotates in such a direction that the tone arm can return. The second half revolution of the main gear pulls the driving arm and then the swing disk rotates reversely in such a direction that the tone arm can make the lead-in movement.

At this moment, two rubber rings mounted on the chucking arm end of the swing disk catch the T.A. driving board under the tone arm by the operation of a guide hole of the mechanical chassis, and tone arm moves in the same direction as the swing disk movement.

At some point of the first half revolution of the swing disk (in the return direction), although the T.A. driving board under the tone arm has a tendency to move owing to the catching of two rubber rings mounted on the chucking arm end of the swing disk, the arm rest stops the tone arm, making only the swing disk slide.

At some point of the second half reverse revolution of the swing disk (in the lead-in direction) in the same way, the T.A. driving board under the tone arm is caught and the tone arm moves in the lead-in direction.

At the same time, the disk size selector is set by moving the S.S. arm with the peripheral part of the swing disk.

When the L.I. adjusting board fixed on the T.A. driving board under the tone arm hits against this disk size selector, the lead-in movement of the tone arm is stopped.

After that, two rubber rings mounted on the chucking arm end of swing disk continue to catch the T.A. driving board, and swing disk slides while turning. At some point of time, the two rubber rings mounted on the chucking arm end release the T.A. driving board under the tone arm by the operation of guide hole of the mechanical chassis.

When the movement of the swing disk is completed, the groove of the swing disk makes the lifter go down, and then the stylus is carried up to the lead-in groove position of the record, finishing the Auto Start Movement.

3) REPEAT MOVEMENT (Fig. 3-4)

By indicating a repeat number by the use of the repeat knob, the repeat cam is set and also link lever pulls the release cam (triangle shape) by a spring usually.

Owing to that, this release cam is hid under the mechanical chassis and does not jut out from the guide hole part of the mechanical chassis, even after the tone arm having automatically returned, the movement of catching the T.A. driving board is continued and then the auto lead-in motion of the tone arm is made continuously by the timing of the mechanical chassis guide hole.

Also, during this lead-in motion, by the second half revolution of the main gear, the groove of the main gear moves the release lever, pulling the feeding levers, and turns back the repeat cam and also the repeat knob is returned one step of repeat number indicate. Therefore, when the repeat action of a repeat number indicated on the repeat knob is completed, the repeat knob returns back at the position OFF, and the auto-return movement, afterward, makes the same as the above-mentioned auto-return movement, and the power supply is turned off automatically after the tone arm having auto-returned.

When an auto-cut is required during the repeat movement, to set the repeat knob to the position OFF makes the repeat movement release.

4) AUTO-CUT MOVEMENT

When a record is required to stop playing, turn the cuing knob to the position AUTO-CUT.

The manual check lever is pulled and the manual cam is also pulled by the link rod (2), pushing the start lever and the sensor lever, and then the above-mentioned auto-return movement is made. (In this case, the repeat knob is required to set at the position OFF).

5) OPERATION DIAGRAM OF AUTO MECHANISM

Part Names of Auto Mechanism

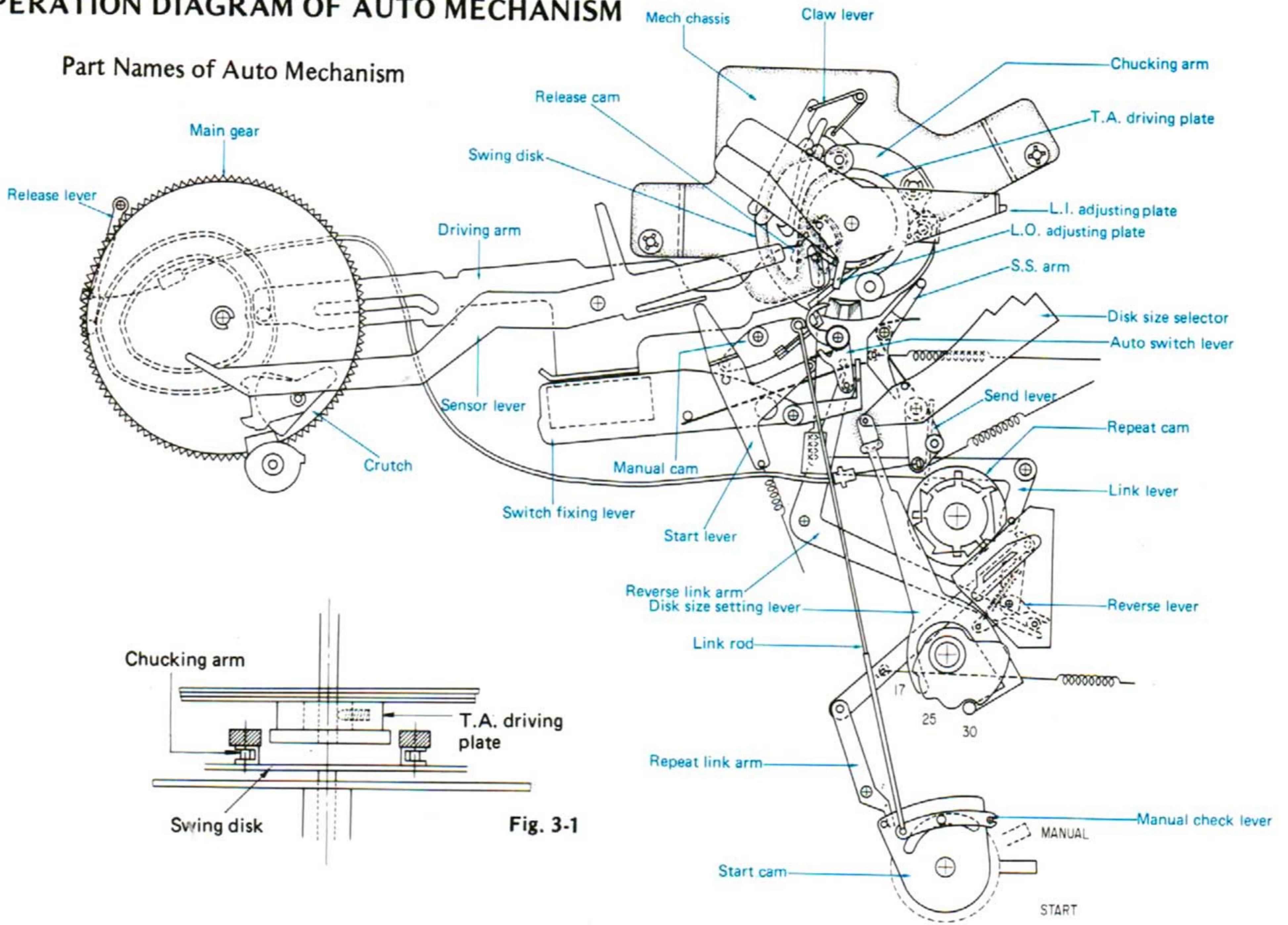

● AUTO-RETURN MOVEMENT

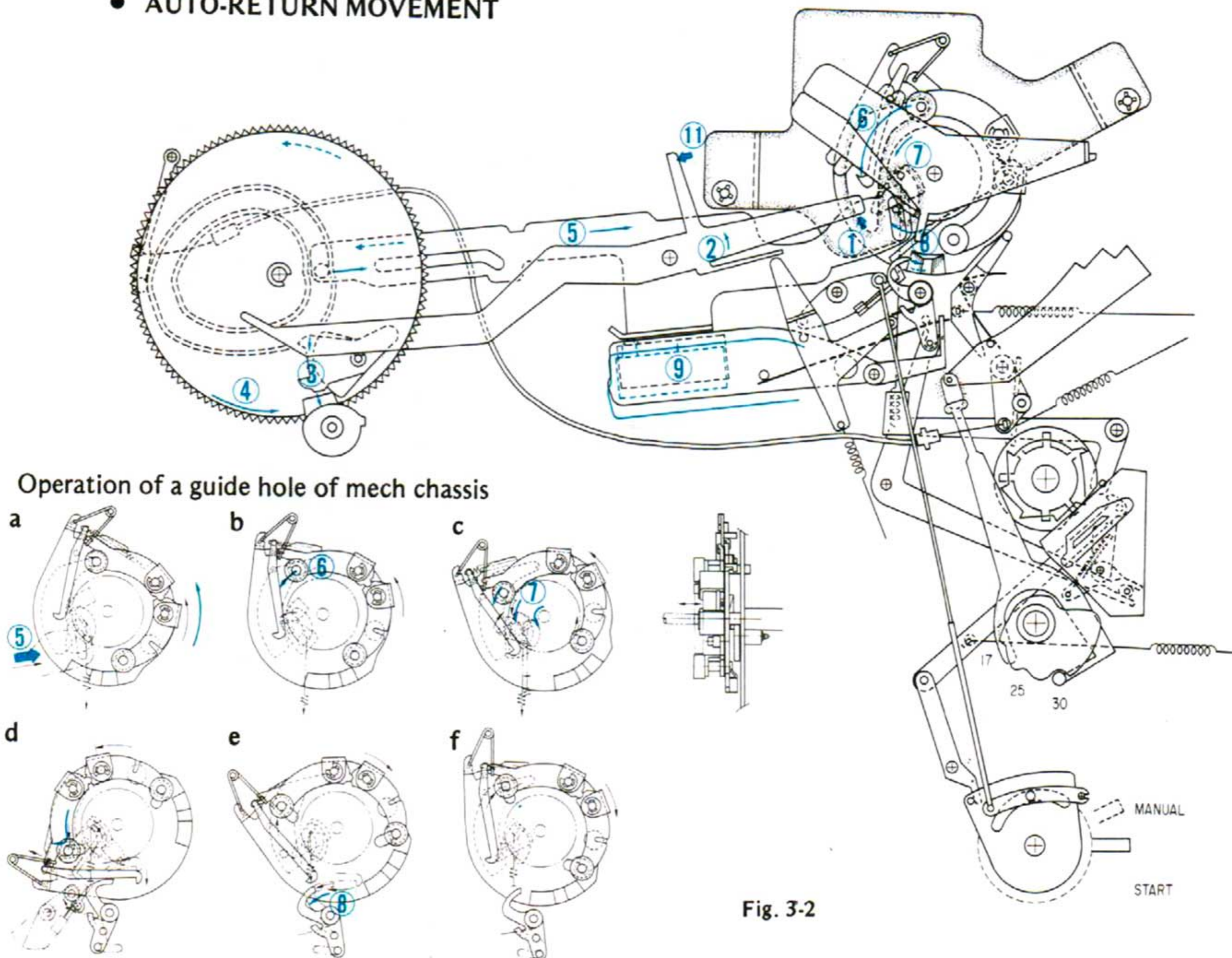

● AUTO-START MOVEMENT

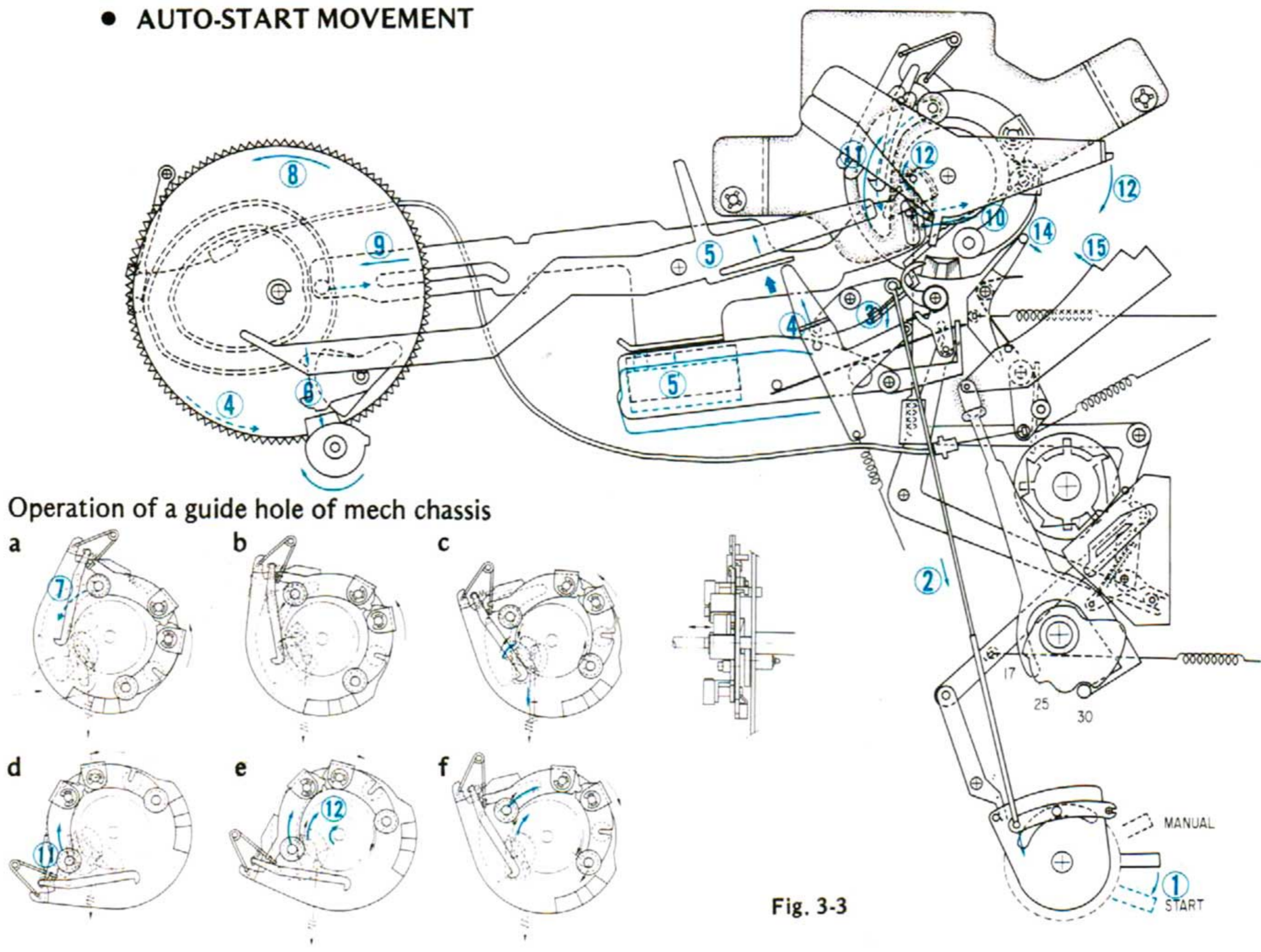

Fig. 3-3

● REPEAT MOVEMENT

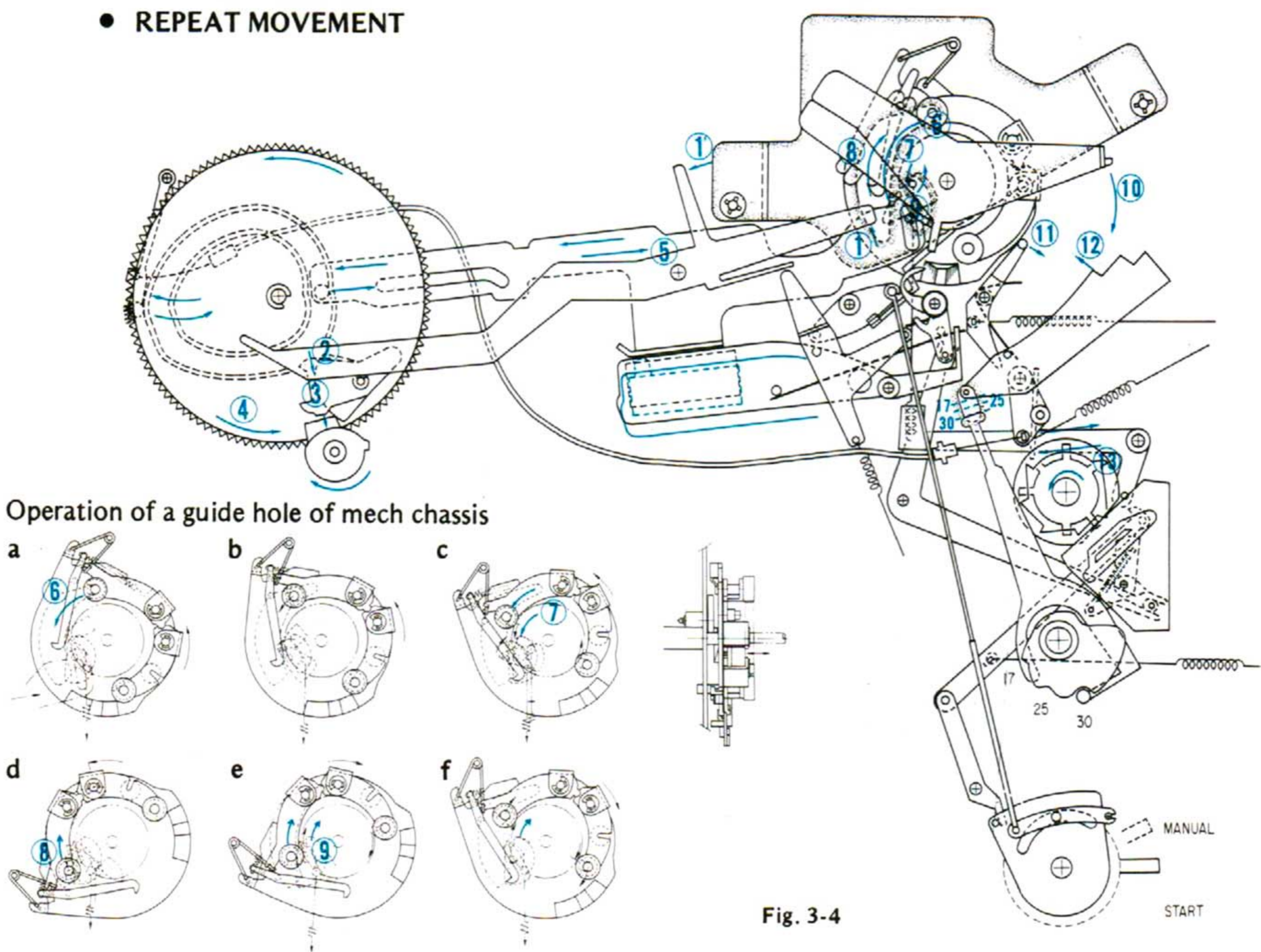

Fig. 3-4

4. MAIN PARTS REPLACEMENT

1) Replacement of Main Chassis Ass'y. (See Bottom View on page 7)

1. Extract the knobs of Repeat and Size Selector.
2. Remove 15 pcs. of screws No. 34 .
3. Take the Bottom Plate off.
4. Remove 3 pcs. of screws No. 13 , one pc. of screw No. 39 and No. 40 .
5. Take off the shield plate over the Circuit Board, S-0012.
6. Disconnect the lead wires soldered on the Circuit Board, S-0012.
7. Disconnect the lead wires soldered on the Circuit Board, S-0020 from the Circuit Boards, S-0018 & S-0019.
8. Pluck out the connectors of each Circuit Board on chassis.
9. Remove 6 pcs. of Nuts No. 36 .

2) Replacement of Tone arm Ass'y (See Exploded View on page 10)

1. Take out chassis (See Replacement 1).
2. Loosen the Hex screw No. 43 with T.A. driving Board.
3. Remove 4 pcs. of screws No. 50 .
4. Take off the Tone arm base Ass'y (SR-737/SR-7090 only).
5. Loosen the screw No. 52 . (SR-737/SR-7090 only).
6. Take off the Light Screening Plate No. 53 . (SR-737/SR-7090 only).
7. Loosen the Hex screw No. 54 .
8. Pull the Tone arm Ass'y upward.

3) Installation of T.A. driving Board Ass'y. (See Exploded View on page 10)

1. Put the Tone arm on the Arm rest.
2. Fix the T.A. driving Board Ass'y as Fig. 4-1, 4-2.
3. Confirm that the Tone arm moves smoothly.

4) Installation of Light Screening Plate. (See Exploded View on page 10)

1. Put the Tone arm on the Arm rest.
2. Fix the Light Screening Plate as Fig. 4-3, 4-4.
3. Confirm that the Tone arm moves smoothly.

5) Installation of Cueing knob Ass'y. (See Exploded View on page 10)

1. Set the Cueing Cam to OFF position as Fig. 4-5.
2. Set the Connection Pin No. 13 to Cueing Cam.
3. Set the Cueing Knob No. 4 to Mark position on panel.

6) Installation of Insulators (See Bottom View on page 7)

Since pressure on each insulator differs at each corner, the springs are distinguished.

Fig. 4-2

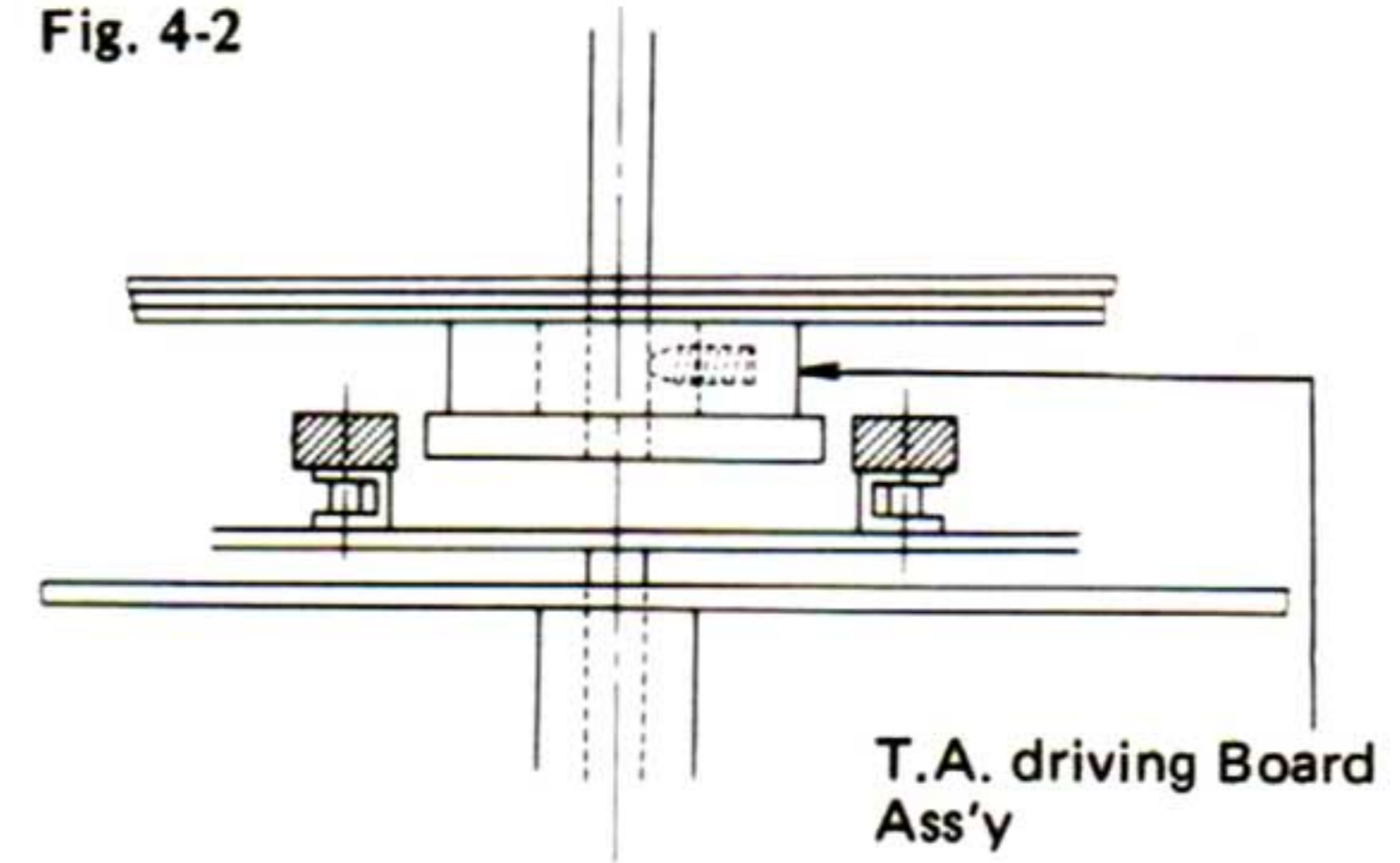

Fig. 4-3

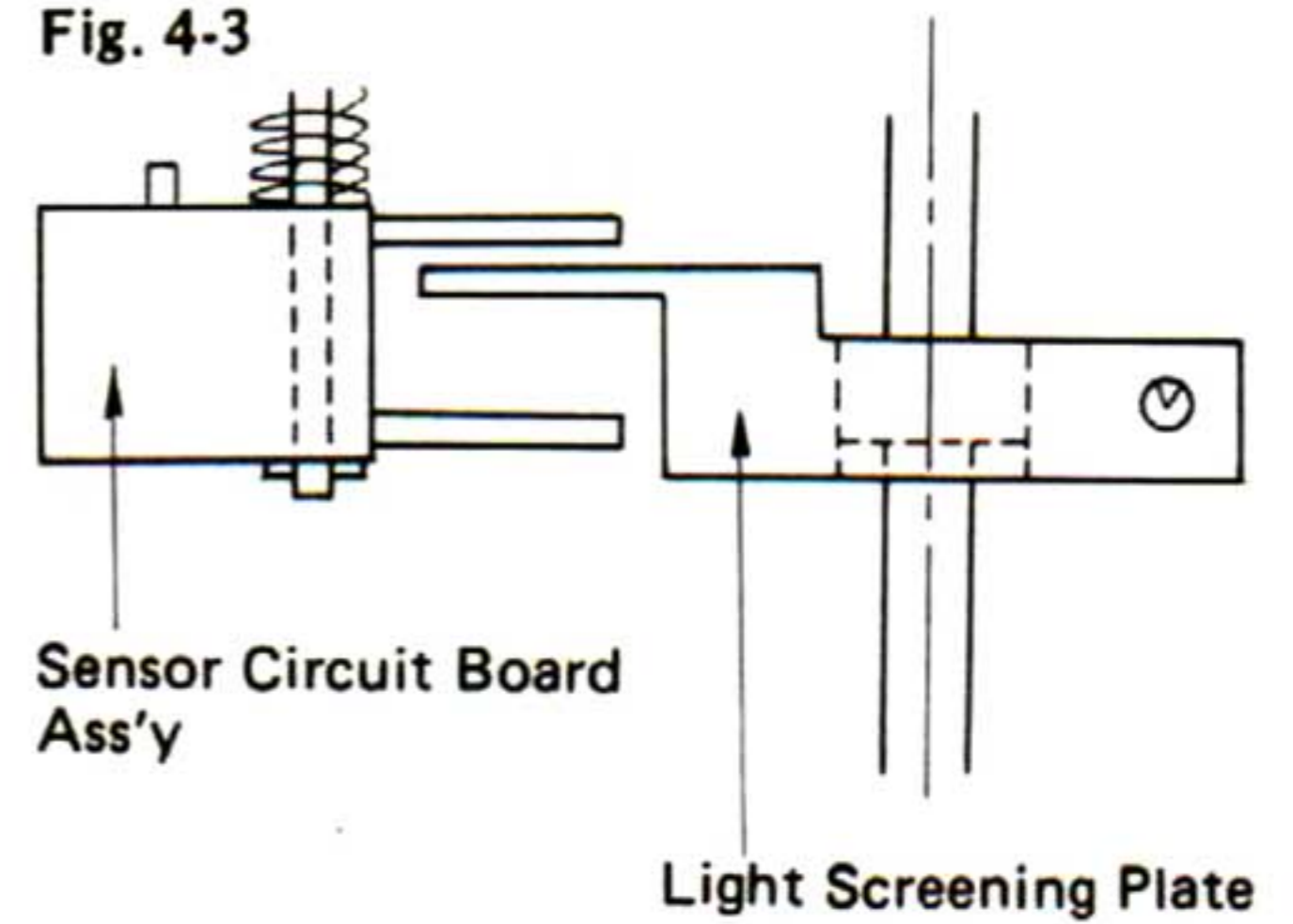

Fig. 4-4

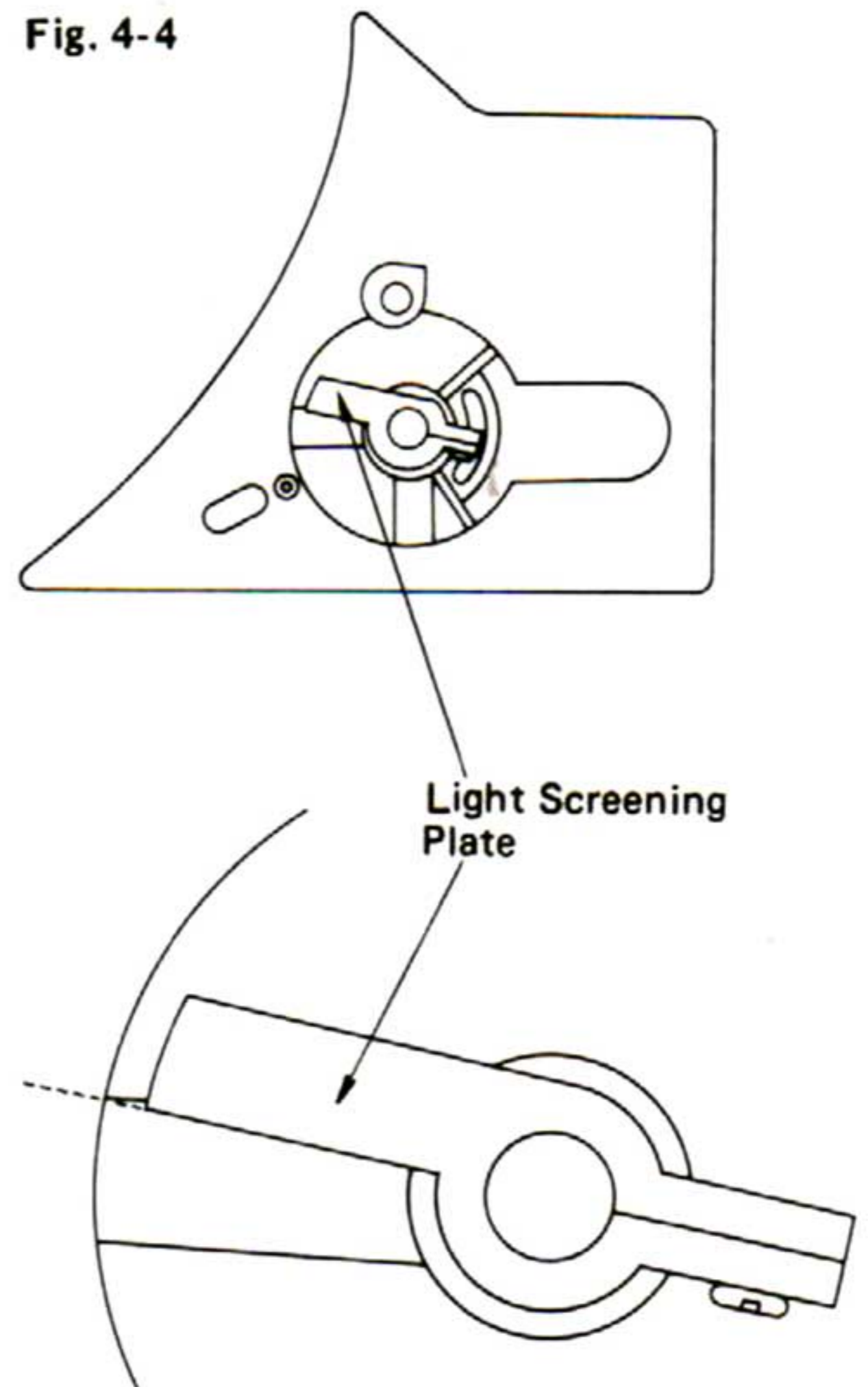

Fig. 4-5

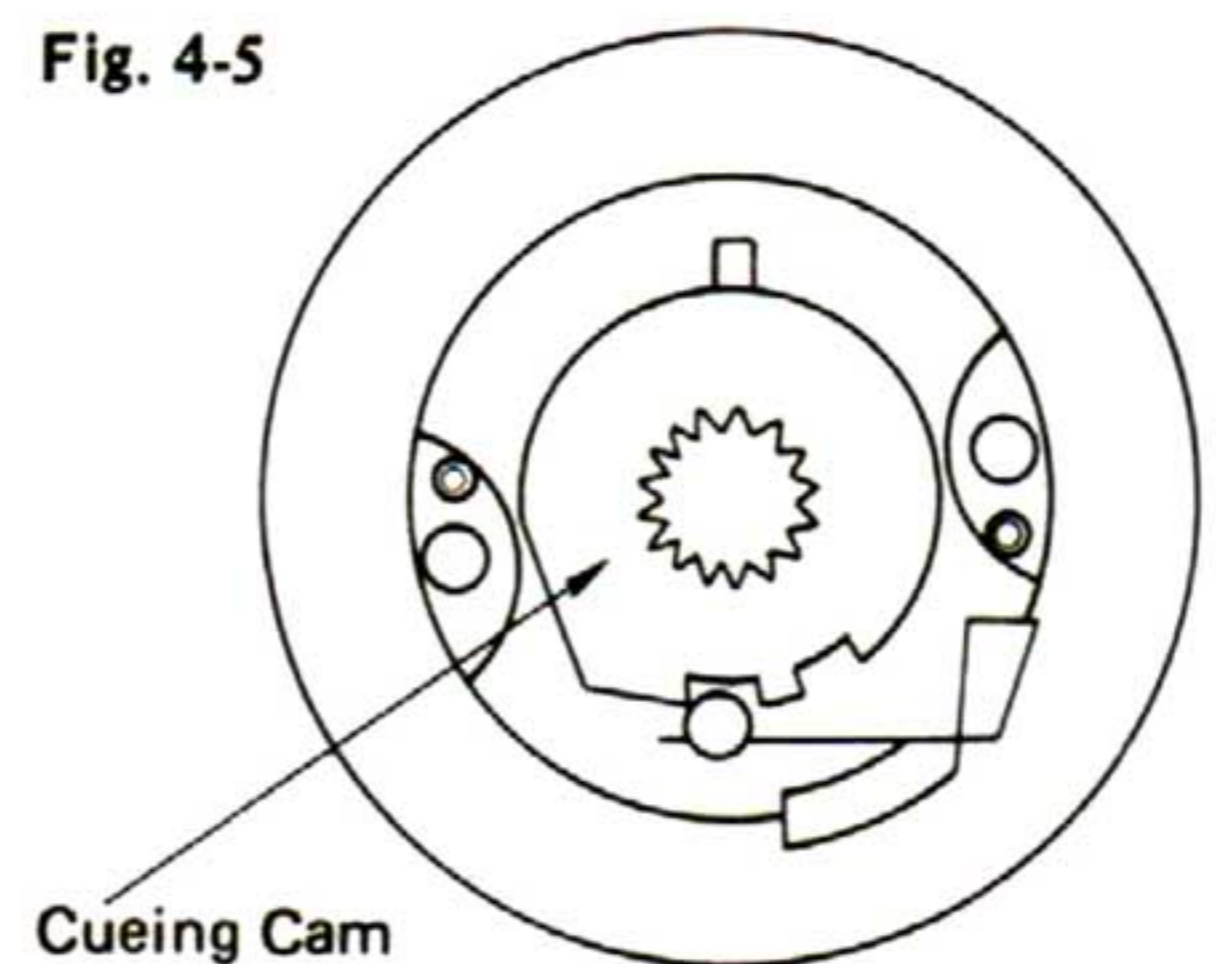
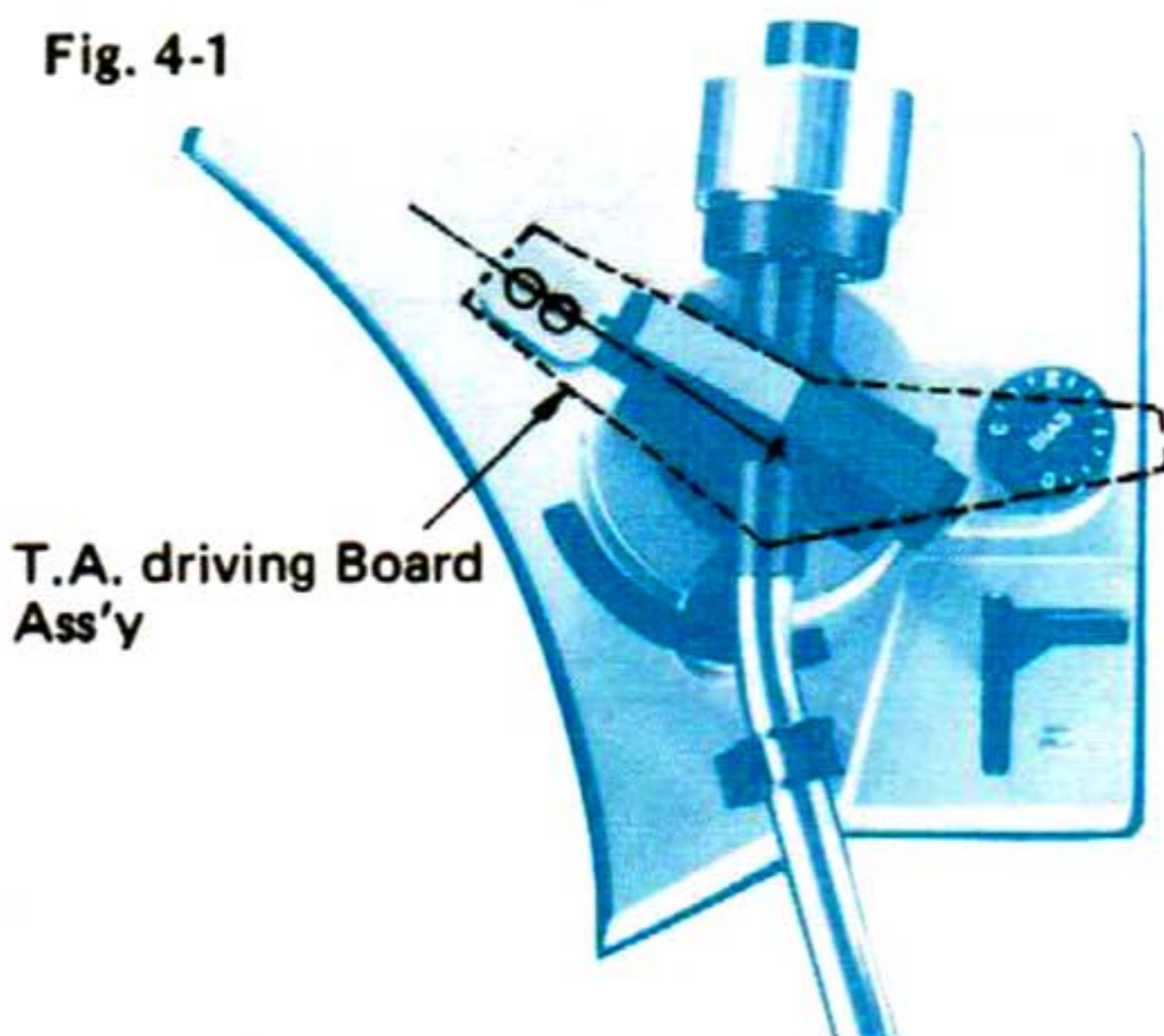

Fig. 4-1



5. MECHANISM PARTS LOCATION AND PARTS LIST

1) Bottom View

SR-535/SR-5090

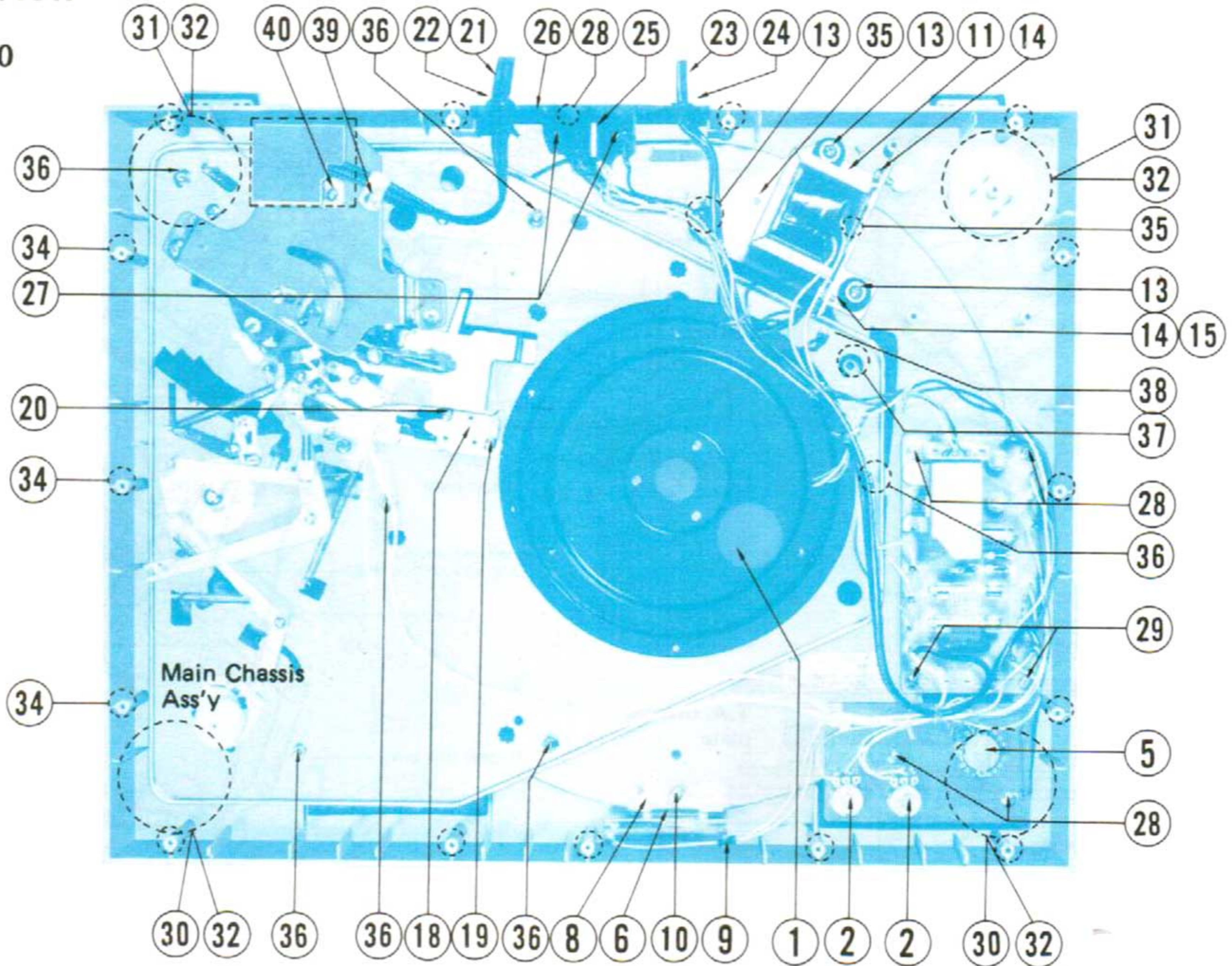

SR-737/SR-7090

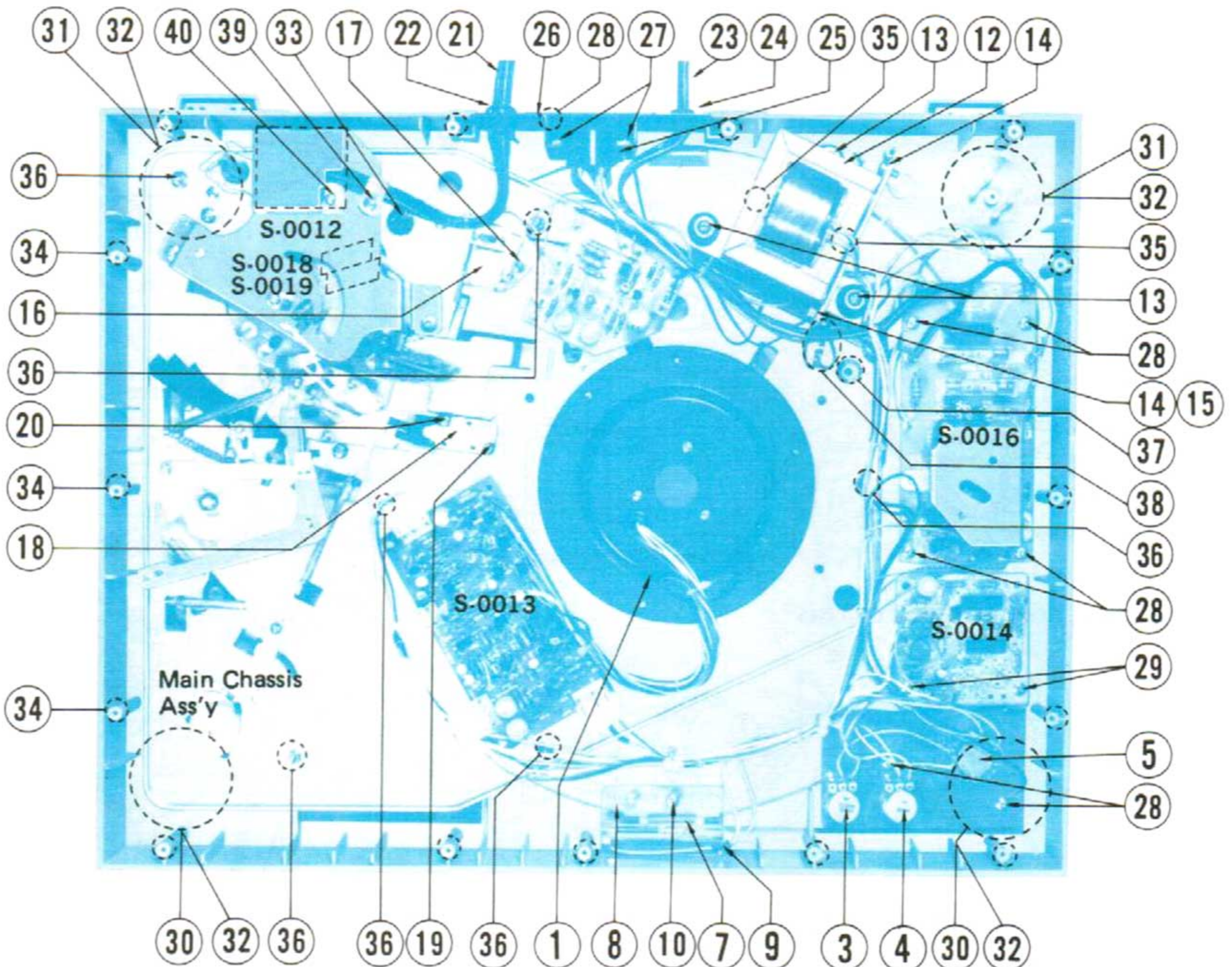

With units sold in U.S.A., Canada and certain European countries, no cartridge is provided.

Parts List (Bottom View)

| Parts No. | Stock No. | Description |
|-----------|--------------------|---|
| 1 | 4320480 | D.D Motor (SR-535, SR-5090) |
| | 4320500 | D.D Motor (SR-737, SR-7090) |
| 2 | VR733, 745 1005330 | Volume 2 kΩ B Pitch Control (SR-535, SR-5090) |
| 3 | VR733 1005111 | Volume 50 kΩ B Pitch Control (33 rpm) (SR-737, SR-7090) |
| 4 | VR745 1005380 | Volume 40 kΩ B Pitch Control (45 rpm) (SR-737, SR-7090) |
| 5 | S 702 1101830 | Speed Selector Switch EU, BS (SR-535, SR-737) |
| | 1101870 | Speed Selector Switch XX, CSA, UL (SR-535, SR-737) |
| | 1101790 | Speed Selector Switch (SR-5090, SR-7090) |
| 6 | NL701 0410130 | Neon Lamp NE-2HUWSA-5 (SR-535, SR-5090) |
| 7 | NL701 0410140 | Neon Lamp NE-2HUWSA-6 (SR-737, SR-7090) |
| 8 | 5262290 | Lamp Holder |
| 9 | 5502841 | Stopper Rubber |
| 10 | 5109122 | BT Type Screw M3 x 8 |
| 11 | PT 01 4002690 | Power Transformer XX (SR-535, SR-5090) |
| | 4002692 | Power Transformer CSA, UL (SR-535) |

| Parts No. | Stock No. | Description |
|-----------|----------------|--|
| | 4002694 | Power Transformer EU, BS (SR-535) |
| 12 | PT 01 4002700 | Power Transformer XX (SR-7090) |
| | 4002702 | Power Transformer CSA, UL (SR-737) |
| | 4002704 | Power Transformer EU, BS (SR-737) |
| 13 | 5502650 | Flowing Rubber, transformer |
| | 5162540 | S Type Screw |
| 14 | 5101862 | BSA Type Screw M4 x 8 |
| 15 | 5122560 | TLE Type Washer 4φ |
| 16 | SL 701 4340170 | Pressure Magnet (SR-737, SR-7090 only) |
| 17 | 5109122 | BT Type Screw M3 x 8 (SR-737, SR-7090 only) |
| 18 | S 701 1160250 | Micro Switch |
| 19 | 5162720 | PSA Type Screw M3 x 16 |
| 20 | 5103545 | PT Type Screw M3 x 16 |
| | 3810290 | P,U Output Cord EU, CSA, BS (SR-5090, SR-7090) |
| 21 | 3810310 | P,U Output Cord XX, UL (SR-535, SR-737) |
| 22 | 3910570 | Strain Relief (8.2φ), output cord |
| 23 | 3800420 | Power Cord XX, CSA, UL |
| | 3800421 | Power Cord EU |
| 24 | 3910600 | Strain Relief (5.2φ), power cord XX, CSA, UL |

| Parts No. | Stock No. | Description |
|-----------|-----------|---|
| 25 | 1190510 | Voltage Selector XX (SR-5090, SR-7090) (SR-535, SR-737) |
| | 1190520 | Voltage Selector EU, BS (SR-737) |
| 26 | 5109222 | BT Type Screw M3 x 8 (black) |
| 27 | 5103543 | PT Type Screw M3 x 10 |
| 28 | 5162700 | BT Type Screw M3 x 10 |
| 29 | 5109122 | BT Type Screw M3 x 8 |
| 30 | 7072090 | Insulator (I) |
| 31 | 7072100 | Insulator (J) |
| 32 | 5107764 | PSB Type Screw M4 x 12 |
| 33 | 5616290 | Cord Bushing (SR-737, SR-7090) |
| 34 | 5162570 | WT Type Screw M3 x 14, bottom plate |
| 35 | 5107764 | PSB Type Screw M4 x 12, shipping screws |
| 36 | 5110261 | H Type Nut M4 x 3.2 |
| | 5121360 | S Type Washer 4φ |
| | 5120161 | P Type Washer 4φ |
| 37 | 5182361 | H Type Nut M4 x 3.2 |
| | 5121360 | S Type Washer 4φ |
| | 5182361 | P Type Washer 4.5φ |
| 38 | 5162700 | BT Type Screw M3 x 10 |
| 39 | 5162700 | BT Type Screw M3 x 10 |
| 40 | 5103543 | PT Type Screw M3 x 10 |

2) Top View

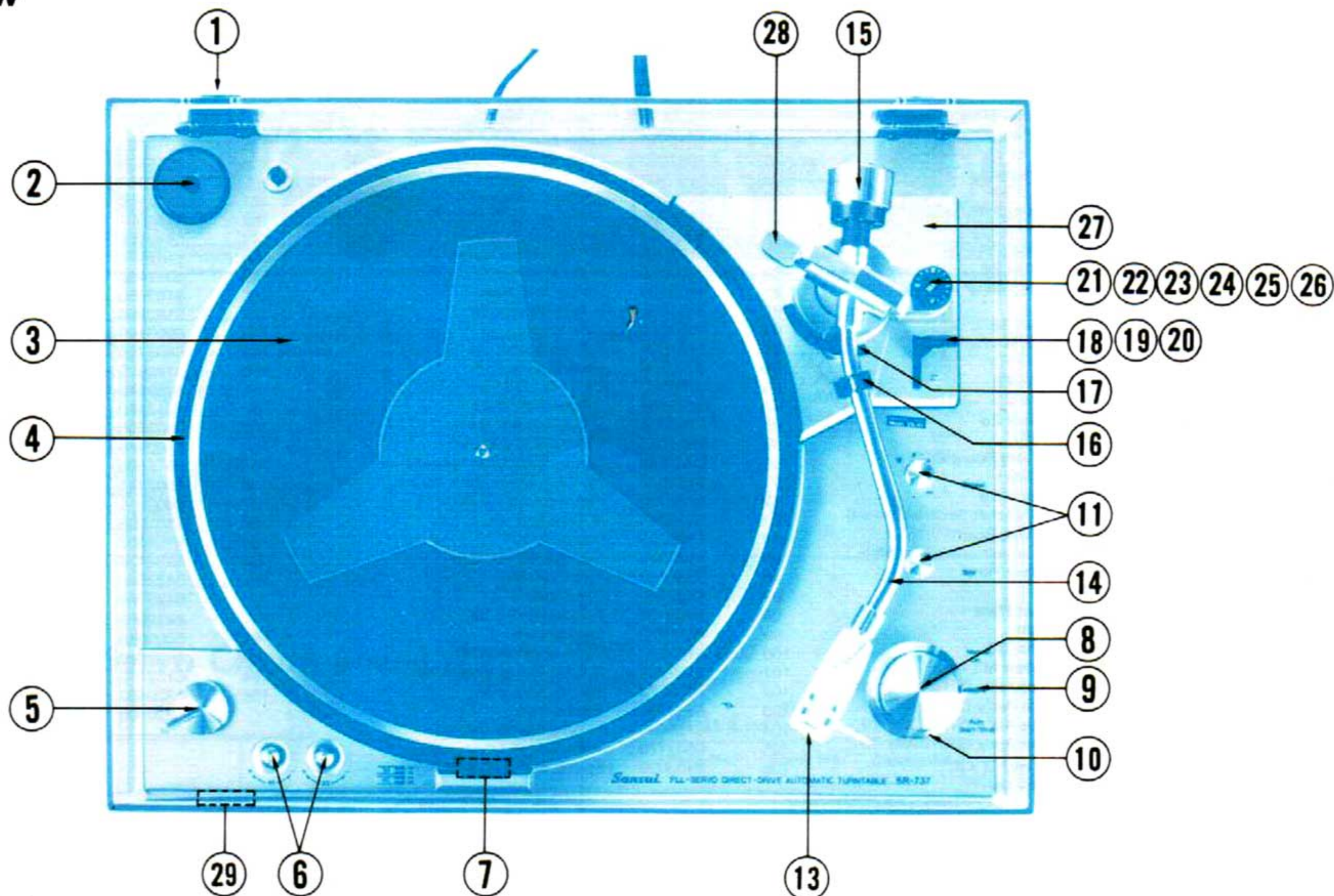

Parts List (Top View)

| Parts No. | Stock No. | Description |
|-----------|-----------|--|
| 1 | 7012161 | Dust Cover Ass'y |
| | 5062342 | Dust Cover |
| | 6922330 | Auto Hinge |
| | 6922340 | Auto Hinge Plate |
| | 5502711 | Rubber Cushion |
| | 5101163 | B Type Screw M4 x 10 |
| 2 | 6172040 | 45 Adaptor |
| 3 | 5502901 | Rubber Mat. turntable XX, UL (SR-535, SR-5090, SR-7090) |
| | 5502891 | Rubber Mat. turntable EU, CSA, BS (SR-737, SR-7090) |
| 4 | 6112183 | Turntable (Platter) (SR-535, SR-5090) |
| | 6112191 | Turntable (Platter) (SR-737, SR-7090) |
| 5 | 5312310 | Knob, speed selector |
| 6 | 4312280 | Knob, pitch control |
| 7 | 5442030 | Illuminator |
| 8 | 5312320 | Knob, cueing (1) |
| 9 | 5312360 | Knob, cueing (2) |
| 10 | 6502870 | Knob, cueing (3) |
| 11 | 531239 | Knob, repeat & Record size |
| 12 | 6642270 | Head Shell (SR-535, SR-5090) |
| | 6642280 | Head Shell (SR-737, SR-7090) |
| 13 | 4310370 | Cartridge Ass'y (SC-50) (with stylus, stylus cover, screw ass'y) (SR-535, SR-5090) XX, AS only |

| Parts No. | Stock No. | Description |
|-----------|-----------|--|
| | 4940230 | Stylus (SN-50) (SR-535, SR-5090) |
| | 5012090 | Stylus Cover XX, AS only |
| | 5192160 | Screw Ass'y |
| | 4310340 | Cartridge Ass'y (SV-43) (with stylus, stylus cover, screw ass'y) (SR-737, SR-7090) XX, AS only |
| 14 | 4940220 | Stylus (SN-43) (SR-535, SR-5090) |
| | 5012080 | Stylus Cover |
| | 5192180 | Screw Ass'y |
| | 7092670 | Tonearm (without main weight) (SR-535, SR-5090) |
| | 7092680 | Tonearm (without main weight) (SR-737, SR-7090) |
| 15 | 6912570 | Main Weight |
| 16 | 6622260 | Arm Rest Ass'y (with screw) |
| 17 | 7082300 | Tonearm Guide Ass'y (with SS Type Setscrew) |
| | 5105520 | SS Type Setscrew M2.6 x 3, tonearm guide |
| 18 | 7052410 | Lifter Lever Ass'y (with SS Type Setscrew) |
| | 5105502 | SS Type Setscrew M2 x 3, Lifter Lever |
| 19 | 6012510 | Lifter Cam Ass'y (with P Type Washer) |
| 20 | 7012170 | Lifter Cam Plate Ass'y (with screw or washers) |

| Parts No. | Stock No. | Description |
|-----------|-----------|---|
| | 5103304 | P Type Screw M2 x 6, lifter cam plate |
| 21 | 7102090 | I.F.C. Knob Ass'y (with SS Type Setscrew) |
| | 5105521 | SS Type Setscrew M2.6 x 4, I.F.C. knob |
| 22 | 6903370 | Click Spring Ass'y (with steel ball 2φ) |
| 23 | 6903360 | Cushion Spring |
| 24 | 6012520 | Canceller Cam |
| 25 | 7052420 | Canceller Lever Ass'y (with E Type Washer 1.5φ) |
| | 5151001 | E Type Washer 1.5φ, canceller lever |
| 26 | 6903380 | Canceller Spring |
| 27 | 7092690 | Tonearm Base Ass'y (with lifter) (SR-535) |
| | 7092770 | Tonearm Base Ass'y (with lifter) (SR-7090) |
| | 7092700 | Tonearm Base Ass'y (with lifter) (SR-737) |
| | 7092780 | Tonearm Base Ass'y (with lifter) (SR-7090) |
| 28 | 5052130 | Cap, adjust |
| 29 | 5332391 | Sansui Badge |







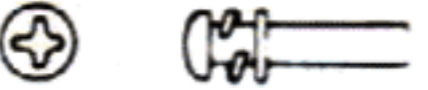
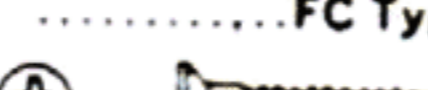
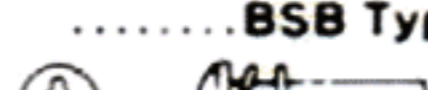
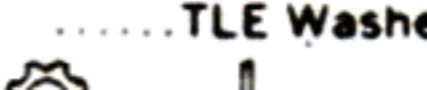

There is no cartridge provided for some XX model.

3) Exploded View

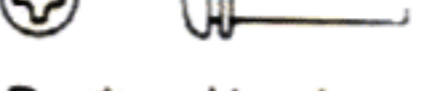
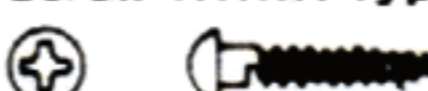
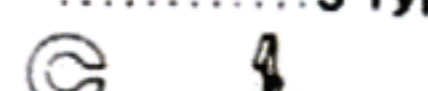
Parts List <Exploded View>

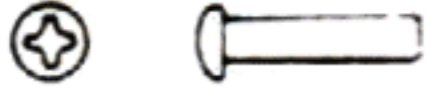
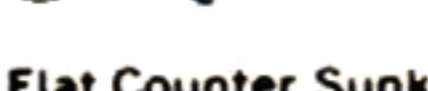
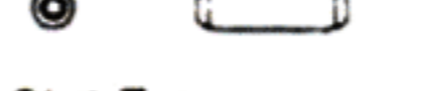
| Parts No. | Stock No. | Description | Position | Parts No. | Stock No. | Description | Position | Parts No. | Stock No. | Description | Position | |
|-----------|-----------|---|-----------------|-----------|-----------|---|--|---------------------------------|-----------|---------------------------|---|--|
| 1 | 5312310 | Speed Selector Knob | | 53 | 5042090 | Light Screening Plate (SR-737, 7090 only) | | 107 | 5182960 | CS Type Washer 2φ | | |
| 2 | 5312390 | Repeat & Record Size Knob | | 54 | 5106143 | SC Type Hex Socket Setscrew M3 x 6 | | 108 | 5182570 | P Type Thrust Washer 4φ | | |
| | 7102100 | Cueing Knob Ass'y (with 3, 4, 6 ~ 12) | | 55 | 7092670 | Tonearm (SR-535, SR-5090) | | 109 | 6903111 | Spring, auto switch lever | | |
| 3 | 5312320 | Cueing Knob (1) | | 56 | 7092680 | Tonearm (SR-737, SR-7090) | | 110 | 5182550 | P Type Thrust Washer 3.5φ | | |
| 4 | 5312361 | Cueing Knob (2) | | | 5182290 | CS Type Washer 3φ (SR-737, 7090 only) | | 111 | 6903200 | Spring (4), SS arm | | |
| 5 | 5109122 | BT Type Screw M3 x 8 | | | 57 | 5232400 | Circuit Board Holder (SR-737, 7090 only) | | 112 | 5151004 | E Type Washer 3φ | |
| 6 | 6502870 | Cueing Knob (3) | | | 58 | 7595621 | S-0018 Circuit Board (SR-737 only) | | 113 | 6903162 | Spring, SS arm | |
| 7 | 5182970 | CS Type Washer 8φ | | | 59 | 7595601 | S-0019 Circuit Board (SR-737 only) | | 114 | 6592030 | SS Arm | |
| 8 | 5232450 | P Type Felt Washer (2) 10.2φ | | | 60 | 5183020 | P Type Nylon Washer 3φ (SR-737, SR-7090 only) | | 115 | 6032180 | Release Wire | |
| 9 | 5183040 | P Type Nylon Washer 10.2φ | | | 61 | 6903282 | Spring, circuit board stopper (SR-737, SR-7090 only) | | 116 | 6903262 | Spring (10), lever base | |
| 10 | 6903170 | Board Spring | | | 62 | 7102090 | Bias Knob Ass'y (with Screw) | | 117 | 5151004 | E Type Washer 3φ | |
| 11 | 6322010 | Steel Ball (4) | | | 63 | 5105521 | SS Type Setscrew M2.6 x 4 | | 118 | 6903130 | Spring, back lever | |
| 12 | 6012391 | Cueing Cam | | | 64 | 6903370 | Click Spring Ass'y (with steel ball) | | 119 | 5182960 | CS Type Washer 2φ | |
| 13 | 5192090 | Connection Pin | | | 65 | 6903360 | Spring, canceler cam | | 120 | 6502810 | Back Lever | |
| 14 | 5107867 | PSA Type Screw M4 x 18 | | | 66 | 6012520 | Canceler Cam | | 121 | 6632190 | Lever Base | |
| 15 | 5232470 | Chassis Hold Washer 4φ | | | 67 | 5151001 | E Type Washer 1.5φ | | 122 | 5151004 | E Type Washer 3φ | |
| 16 | 5312280 | Pitch-Control Knob | | | 68 | 7052420 | Canceler Lever Ass'y | | 123 | 6502820 | Disk Size Selector | |
| 17 | 5332091 | Sansui Mark | | | 69 | 6903380 | Spring, canceler lever | | | 7062340 | Repeat Cam Ass'y (with 124 ~ 130) | |
| 18 | 5110261 | H Type Nut M4 x 3.2 | | | 70 | 5105520 | SS Type Setscrew M2.6 x 3 | | 124 | 5182970 | CS Type Washer 8φ | |
| 19 | 5121360 | S Type Washer 4φ | | | 71 | 7082300 | Tonearm Guide Ass'y (with 69) | | 125 | 6012411 | Repeat Cam (2) | |
| 20 | 5120161 | P Type Washer 4φ | | | 72 | 5103304 | P Type Screw M2 x 6 | | 126 | 5182270 | CS Type Washer 4φ | |
| 21 | 5182361 | P Type Washer M4.5 x 18 | | | 73 | 5124001 | P Type Washer 2φ, lifter cam plate | | 127 | 5120161 | P Type Washer 4φ | |
| 22 | 5162700 | BT Type Screw M3 x 10 | | | 74 | 7012170 | Lifter Cam Plate Ass'y (with 71 72) | | 128 | 6903070 | Spring, repeat cam | |
| 23 | 6903270 | Spring, pu cord | | | 75 | 6012510 | Lifter Cam Ass'y | | | 5182650 | P Type Thrust Washer 6.2φ | |
| 24 | 5103543 | PT Type Screw M3 x 10 | | | | 76 | 5105502 | Lifter Lever Ass'y (with screw) | | 6012381 | Repeat Cam (1) | |
| 25 | 5032060 | Shield Plate | | | | 77 | 5105640 | SS Type Setscrew M2 x 3 | | 6522070 | Friction Washer | |
| 26 | 5162700 | BT Type Screw M3 x 10 | | | | 78 | 6622260 | SF Type Setscrew M3 x 3 | | 6903220 | Spring (6), link lever | |
| 27 | 3910160 | Nylon Cord Stopper | | | | 79 | 5052130 | Arm Rest Ass'y (with 76) | | 6502850 | Link Lever | |
| 28 | 2593661 | S-0012 Printed Board for connections | | | | 80 | 5182990 | Cap, adjust | | 7062350 | Repeat Grooved Cam Ass'y (with 133 ~ 138) | |
| 29 | 3810290 | PU Output Cord EU, CSA, BS (SR-5090, SR-7090) | SR-535, SR-737 | | | 81 | 5502770 | P Type Thrust Washer 2φ | | 6903191 | Spring (3), reverse cam | |
| | 3810310 | PU Output Cord UL, XX | | | | 82 | 6903120 | Rubber | | 5151002 | E Type Washer 2φ | |
| 30 | 5101862 | BSA Type Screw M4 x 8 | | | | 83 | 5151004 | Spring, link lever | | 6502800 | Reverse Lever | |
| | 7142100 | Mechanical Chassis Ass'y (with 31 ~ 41) | | | | 84 | 5151004 | E Type Washer 3φ | | 6092020 | Reverse Cam | |
| 31 | 5202181 | Mechanical Chassis | | | | 85 | 6512180 | Reverse Link Arm | | 5100946 | BT Type Screw M3 x 12 | |
| 32 | 5151004 | E Type Washer 3φ | | | | 86 | 5103543 | PT Type Screw M3 x 10 | | 6012363 | Repeat Grooved Cam | |
| 33 | 6903101 | Spring, chucking arm | | | | 87 | 5120161 | P Type Washer 4φ | | 6903180 | Spring (2), repeat link arm | |
| 34 | 6502840 | Claw Lever | | | | 88 | 5151004 | E Type Washer 3φ | | 5182960 | CS Type Washer 2φ | |
| | 6903231 | Spring (7), claw | | | | 89 | 6592040 | Switch Fixing Board | | 6512170 | Repeat Link Arm (2) | |
| | 5183000 | CS Type Washer 2φ | | | | 90 | 6903140 | Spring, switch fixing board | | 5151004 | E Type Washer 3φ | |
| | 5183030 | P Type Thrust Washer 2.5φ | | | | 91 | 5103545 | PT Type Screw M3 x 16 | | 6512160 | Repeat Link Arm (1) | |
| 35 | 6592070 | Swing Disk | | | | 92 | 5162720 | PSA Type Screw M3 x 16 | | 5182970 | CS Type Washer 8φ | |
| 36 | 5151004 | E Type Washer 3φ | | | | 93 | 5110241 | H Type Nut 3φ | | 6012450 | Start Cam | |
| | 5182570 | P Type Thrust Washer 4.0φ | | | | 94 | 1160250 | Micro-Switch | | 5182960 | CS Type Washer 2φ | |
| | 6592051 | Chucking Arm (1) | | | | 95 | 5182960 | CS Type Washer 2φ | | 6903190 | Spring (3), manual check lever | |
| | 6592060 | Chucking Arm (2) | | | | 96 | 6532150 | Link Rod (2) | | 6502780 | Manual Check Lever | |
| | 5502760 | Arm Rubber | | | | 97 | 6502750 | Cam Lever | | 5182970 | CS Type Washer 8φ | |
| | 5183000 | CS Type Washer 2φ | | | | 98 | 5151004 | E Type Washer 3φ | | 5232440 | P Type Felt Washer (1) 8.2φ | |
| | 6012430 | Release Cam | | | | 99 | 6012370 | Manual Cam | | 6012440 | Select Cam | |
| | 7062330 | Tonearm Driving Board Ass'y (with 42 ~ 49) | | | | 100 | 5182960 | CS Type Washer 2φ | | 6502830 | Disk Size Select Arm | |
| 42 | 5151005 | C Type Washer 10φ | | | | 101 | 5182330 | P Type Thrust Washer 4φ | | 5100946 | PT Type Screw M3 x 12 | |
| 43 | 5106061 | SF Type Hex Socket Setscrew M4 x 6 | | | | 102 | 6903210 | Spring, start lever | | 6912560 | Balance Weight | |
| 44 | 6912403 | Tonearm Driving Board | | | | 103 | 6502790 | Start Lever | | 6502741 | Sensor Lever | |
| 45 | 6903241 | Spring (8), lead-out orin adjust plate | | | | 104 | 5151004 | E Type Washer 3φ | | 6502911 | Driving Arm | |
| 46 | 6502880 | Lead-out Adjust Plate | | | | 105 | 6502770 | Auto Switch Lever | | 5151005 | E Type Washer 4φ | |
| 47 | 6502901 | Cam Holder | | | | 106 | 6903090 | Spring, auto switch lever | | 5151002 | E Type Washer 2φ | |
| 48 | 6502891 | Lead-in Adjust Plate | | | | | | | | 5232420 | P Type Nylon Washer 2φ | |
| 49 | 6012462 | Adjusting Cam | | | | | | | | 6422040 | E Trip (Upper) (SR-535, SR-5090) | |
| | 5182980 | W Type Washer 3φ | | | | | | | | 6422050 | E Trip (Under) (SR-535, SR-5090) | |
| 50 | 5101944 | BSB Type Screw M3 x 8 | | | | | | | | 6422060 | E Trip (SR-737, SR-7090) | |
| 51 | 7092690 | Tonearm Base Ass'y (SR-535) | with 54, 69, 70 | | | | | | | 6002050 | Main Gear | |
| | 7092770 | Tonearm Base Ass'y (SR-5090) | | | | | | | | 6502860 | Release Lever | |
| | 7092700 | Tonearm Base Ass'y (SR-737) | | | | | | | | 5162710 | PT Type Screw M4 x 8 | |
| | 7092780 | Tonearm Base Ass'y (SR-7090) | | | | | | | | 4320480 | D.D Motor (SR-535, SR-5090) | |
| 52 | 5109122 | BT Type Screw M3 x 8 (SR-737, 7090 only) | | | | | | | | 5320500 | D.D Motor (SR-737, SR-7090) | |

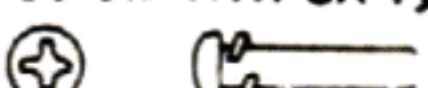
Abbreviations

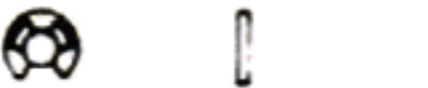
| | | | | |
|--|---|--|--|---|
| 1. Pan Head Tapping ScrewPT Type  | 5. Pan Head SEMS B ScrewPSB Type  | 9. Flat Counter Sunk Wood ScrewFC Type  | 13. Binding Head SEMS B ScrewBSB Type  | 17. Toothed Lock Washer (External)TLE Washer  |
| 2. Washer Head Tapping ScrewWT Type  | 6. Binding Head SEMS F Screw ..BSF Type  | 10. Round Head Wood ScrewRH Type  | 14. Spring WasherS Type  | 18. Wave Washer  |
| 3. Pan Head ScrewP Type  | 7. Binding Head ScrewB TYPE  | 11. Hex. Socket Setscrew ..SC Type  | 15. Plain WasherP Type  | 19. Hexagon Nut H Type Nut  |
| 4. Pan Head SEMS A ScrewPSA Type  | 8. Flat Counter Sunk Head Screw ..F Type  | 12. Slot Type Setscrew ..SS Type  | 16. Retaining Ring (E Washer)..E Type  | |

Exploded View

- 25
 - 40
 - 60
 - 80
 - 100
 - 120
 - 140
 - 165
- 1
 - 26
 - 41
 - 61
 - 81
 - 101
 - 121
 - 141

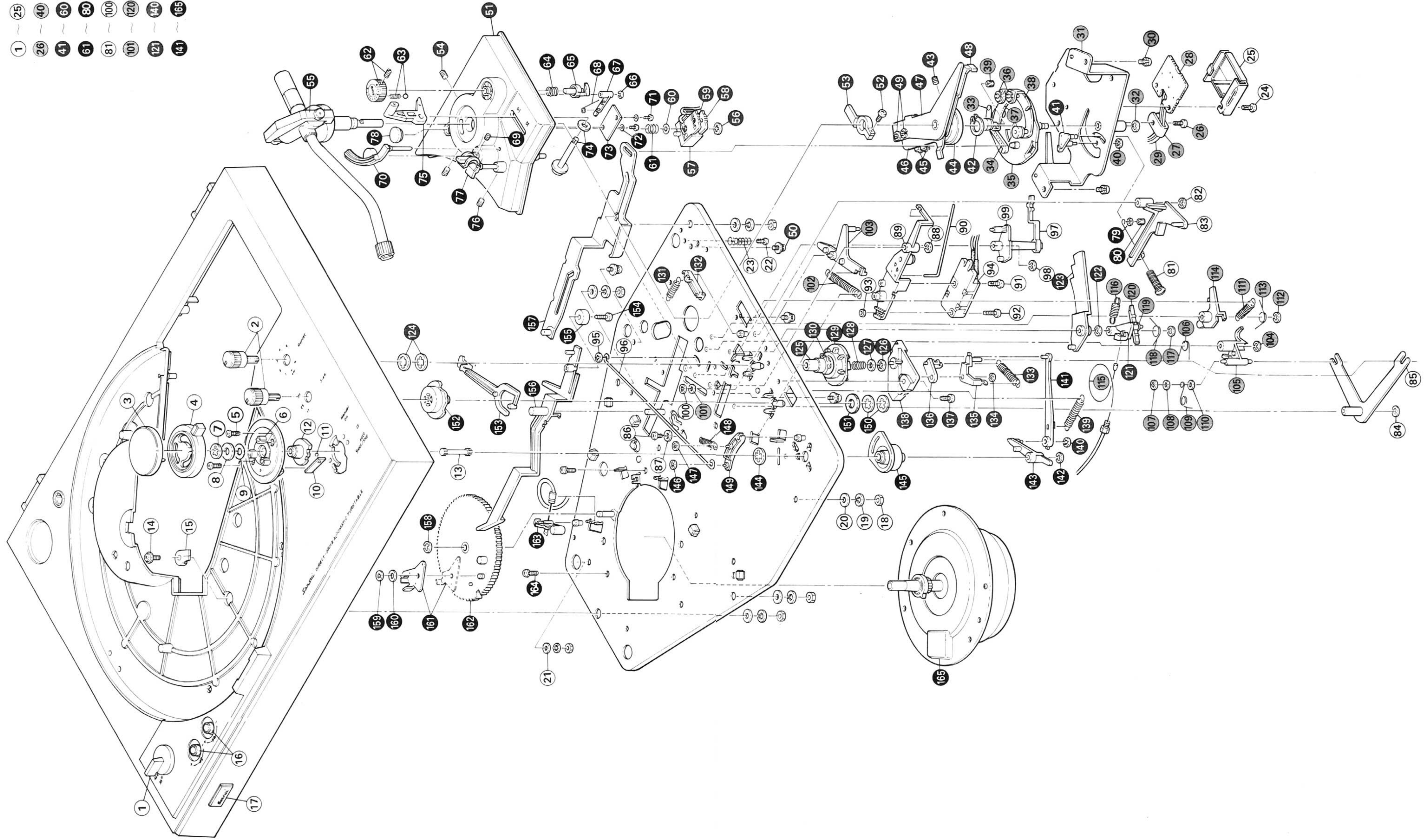

6. PARTS LOCATION & PARTS LIST

Since some of capacitors and resistors are omitted from parts lists in this Service Manual, refer to the common parts list for capacitors & resistors which was appended previously to each Sansui Manual.

1) S-0013 Motor Control Circuit Board (Stock No. 7595771 SR-737/SR-7090)

Conductor Side

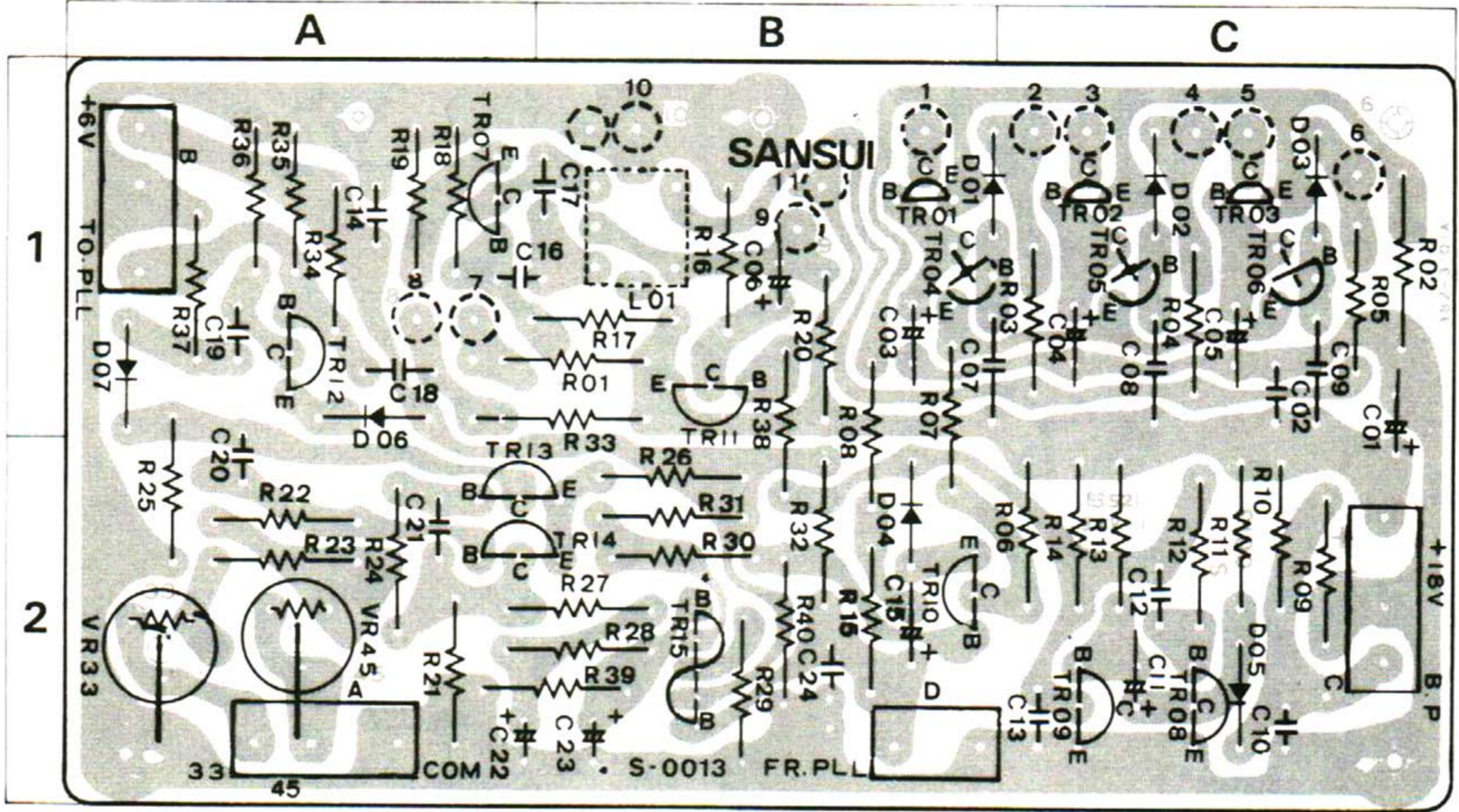

Parts List

| Parts No. | Stock No. | Description | Position | Parts No. | Stock No. | Description | Position | Parts No. | Stock No. | Description | Position |
|-----------|-------------|------------------|------------|-----------|-----------|--------------------|-------------|-----------|-----------|------------------|-------------|
| TR01 ~ 03 | 0308590, 2 | 2SD471 (M, L, K) | 1B, 1C | C 10 | 0656223 | 22000pF } 25V C.C. | 2C | R 01 | 0200222 | 2.2kΩ | 1/2W N.I.R. |
| TR04 ~ 06 | 0300680, 1 | 2SA733 (P, Q) | 1B, 1C | C 14 | 0656223 | 22000pF | 1A | R 02 | 0200272 | 2.7kΩ | |
| TR07 ~ 09 | 0305951 ~ 3 | 2SC945 (Q, P, K) | 1A, 1C | C 20 | 0625103 | 10000pF 50V P.C. | 2A | | 0200332 | 3.3kΩ | |
| TR10 | 0305952 | 2SC945 (P) | Transistor | C 24 | 0656223 | 22000pF 25V C.C. | 2B | R 01 | 0200229 | 2.2ΩM | 1C |
| TR11, 12 | 0300680, 1 | 2SA733 (P, Q) | | 1B, 1A | | 0200821 | 820Ω | | VR33 | 1035190 | 100kΩ (B) |
| TR13, 14 | 0300680 | 2SA733 (P) | 2A | R 01 | 0200102 | 1kΩ | | VR45 | 1035190 | 100kΩ (B) | 2A |
| TR15 | | 2SC1583 (G) | 2B | | 0200122 | 1.2kΩ | 1/2W N.I.R. | L 01 | 4220700 | OSC Coil | 1B |
| D 01 ~ 07 | 0311050 | 1S953 Diode | 1B | | 0200152 | 1.5kΩ | | LD01 | 0319140 | SR106C L.E.D. | |
| C 02 | 0656223 | 22000pF 25V C.C. | 1C | | 0200182 | 1.8kΩ | 1B | TR20 | 0390010 | PH101 Transistor | |

2) S-0014 PLL Servo Circuit Board (Stock No. 7595581) SR-737 (Stock No. 7595981) SR-7090

Conductor Side

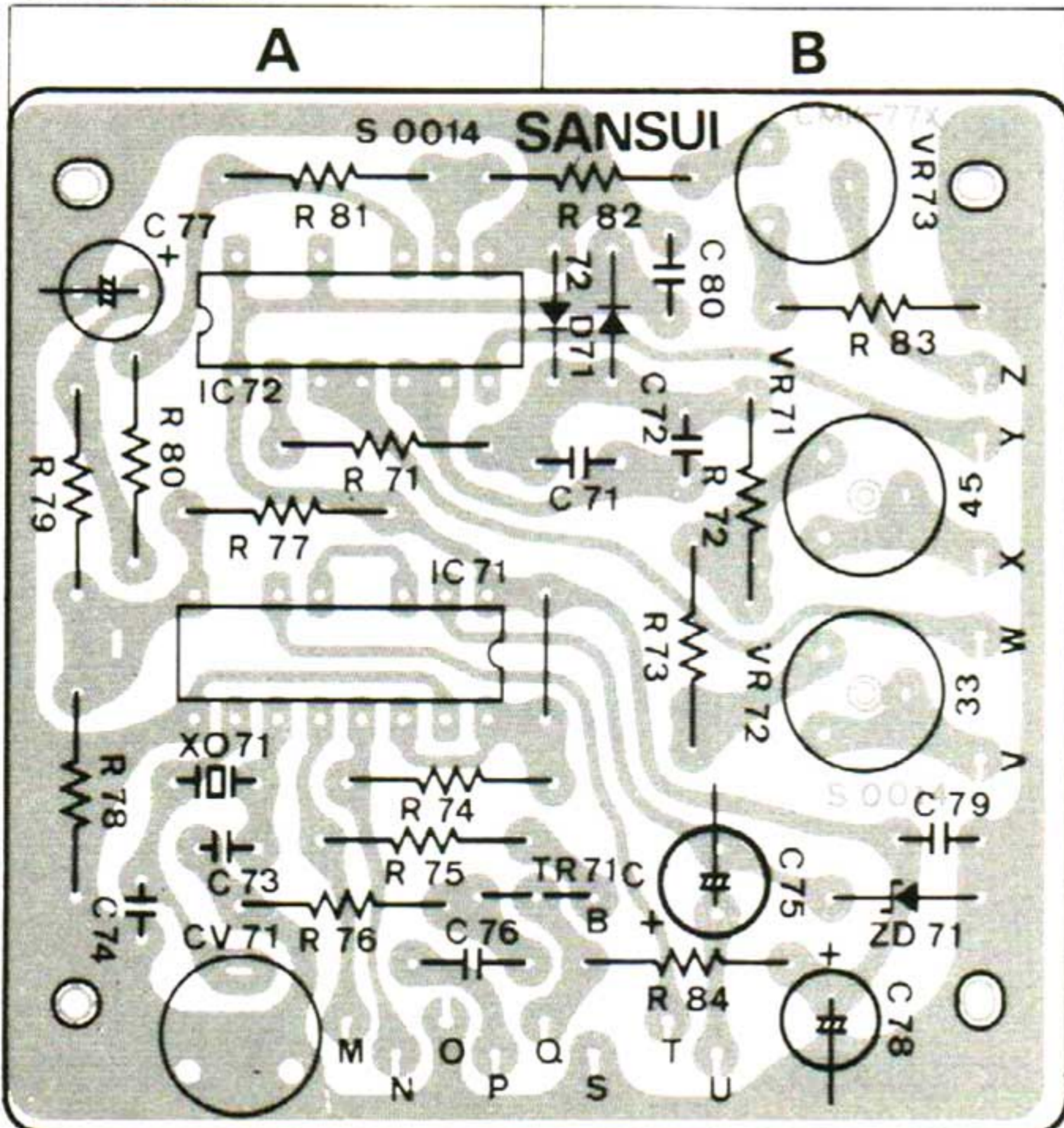

Parts List

| Parts No. | Stock No. | Description | Position |
|-----------|-----------|-----------------------|----------|
| IC 71 | 0360560 | MSM5810 | A |
| IC 72 | 0360570 | MSM4069 | A |
| ZD71 | 0315770 | EQA01.065 Zener Diode | B |
| C 79, 80 | 0657223 | 22000pF 50V C.C. | B |
| R 72 | 0231334 | 330kΩ 1/2W M.R. | |
| R 73 | 0231154 | 150kΩ 1/2W M.R. | |
| VR71, 72 | 1034360 | 330kΩ (B) | B |
| VR73 | 1035160 | 33kΩ (B) | |

3) S-0016 Power Supply Circuit Board (Stock No. 7502541 XX, 7502543 EU, 7502544 CSA, 7502548 UL, 7502549 BS) SR-737 (Stock No. 7502711) SR-7090

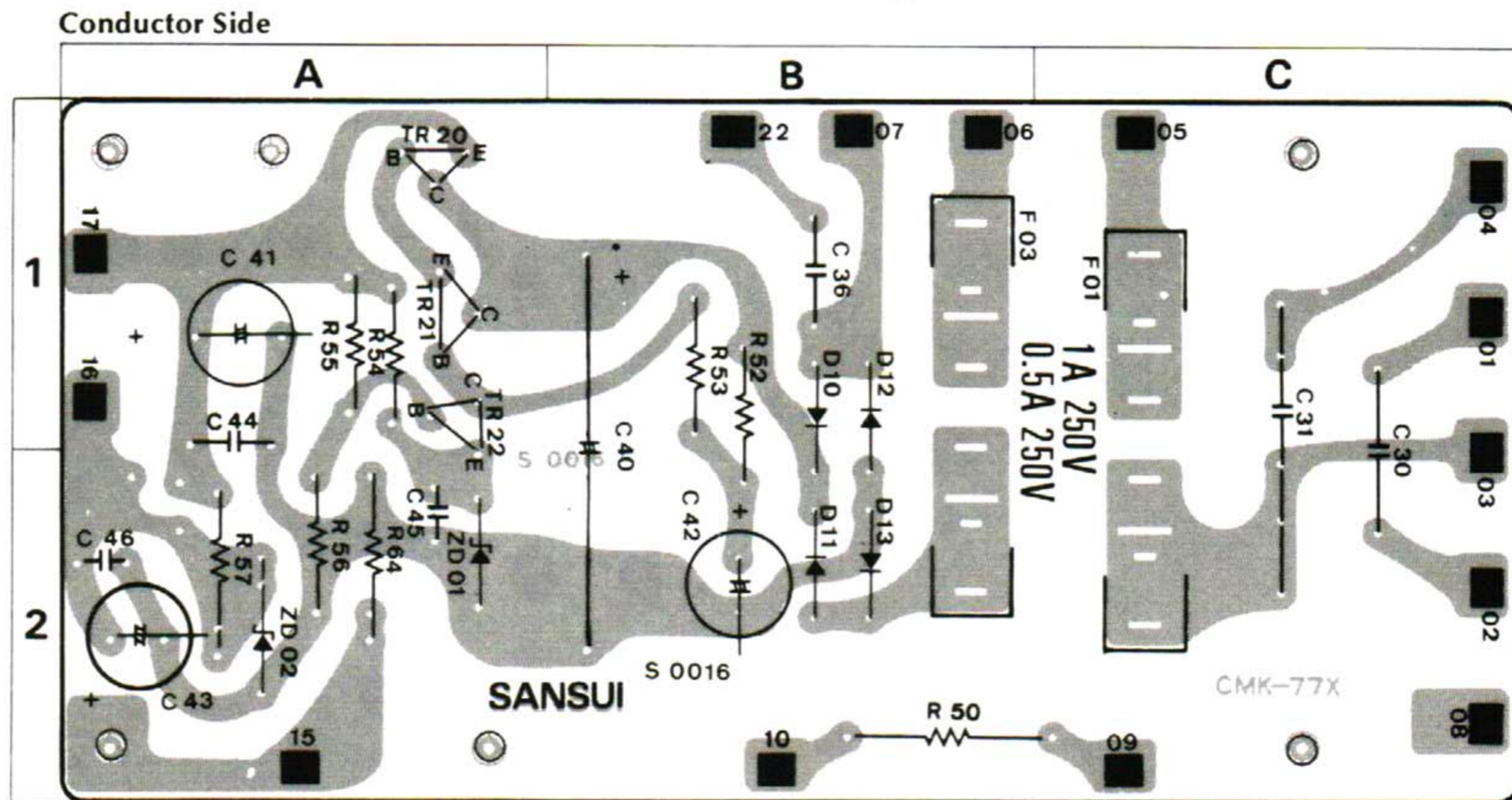

Parts List

| Parts No. | Stock No. | Description | Position | Parts No. | Stock No. | Description | Position | Parts No. | Stock No. | Description | Position |
|-----------|-----------|-------------------------------|---------------|-----------|-----------|-----------------------------------|----------|-----------|-----------|------------------------------------|----------|
| TR 20 | 0306541 | ~ 32SC1986 (Q, Y, G) | Transistor 1A | | 0635337 | 0.033μF 125V P.C. C.S.A. (SR-737) | | F · 01 | 0432210 | 0.5A 250V AC Fuse XX, C.S.A., UL | 1, 2C |
| TR 21 | 0305951 | ~ 32SC945 (Q, P, K) | | C 36 | 0602108 | 0.1μF 100V M.C. EU, BS | | F 03 | 0432220 | 1A 250V AC Fuse XX, C.S.A., UL | 1, 2B |
| TR 22 | 0306070 | ~ 22SC1313 (F, G, H) | | | 0505471 | 470μF 50V E.C. | 1, 2B | | 0435090 | 800mA 250V AC Fuse EU, BS (SR-737) | |
| D 10 ~ 13 | 0310340 | 10D1 Diode | 1, 2B | C 44 | 0656473 | 47000pF 25V C.C. | 1A | | 2310220 | Fuse Holder (Large) XX, C.S.A., UL | |
| ZD01 | 0316630 | RD5.1E Zener Diode | 2A | R 50 | 0211333 | 33kΩ 1W N.I.R. EU, BS (SR-737) | 2B | | 2310230 | Fuse Holder (Small) EU, BS | |
| ZD02 | 0315580 | EQB01-07 Zener Diode | 2A | R 57 | 0211123 | 12kΩ 1W N.I.R. XX, C.S.A., UL | | | | | |
| C 30, 31 | 0598337 | 0.033μF 250V M.C. EU, BS | | | 0211391 | 390Ω 1W N.I.R. | 2A | | | | |
| C 31 | 0603337 | 0.033μF 125V M.C. UL (SR-737) | | | | | | | | | |
| | 0605337 | 0.033μF 250V M.C. XX (SR-737) | | | | | | | | | |

4) S-0020 Sensor Amplifier Circuit Board (Stock No. 7595561) SR-737 (Stock No. 7595971) SR-7090

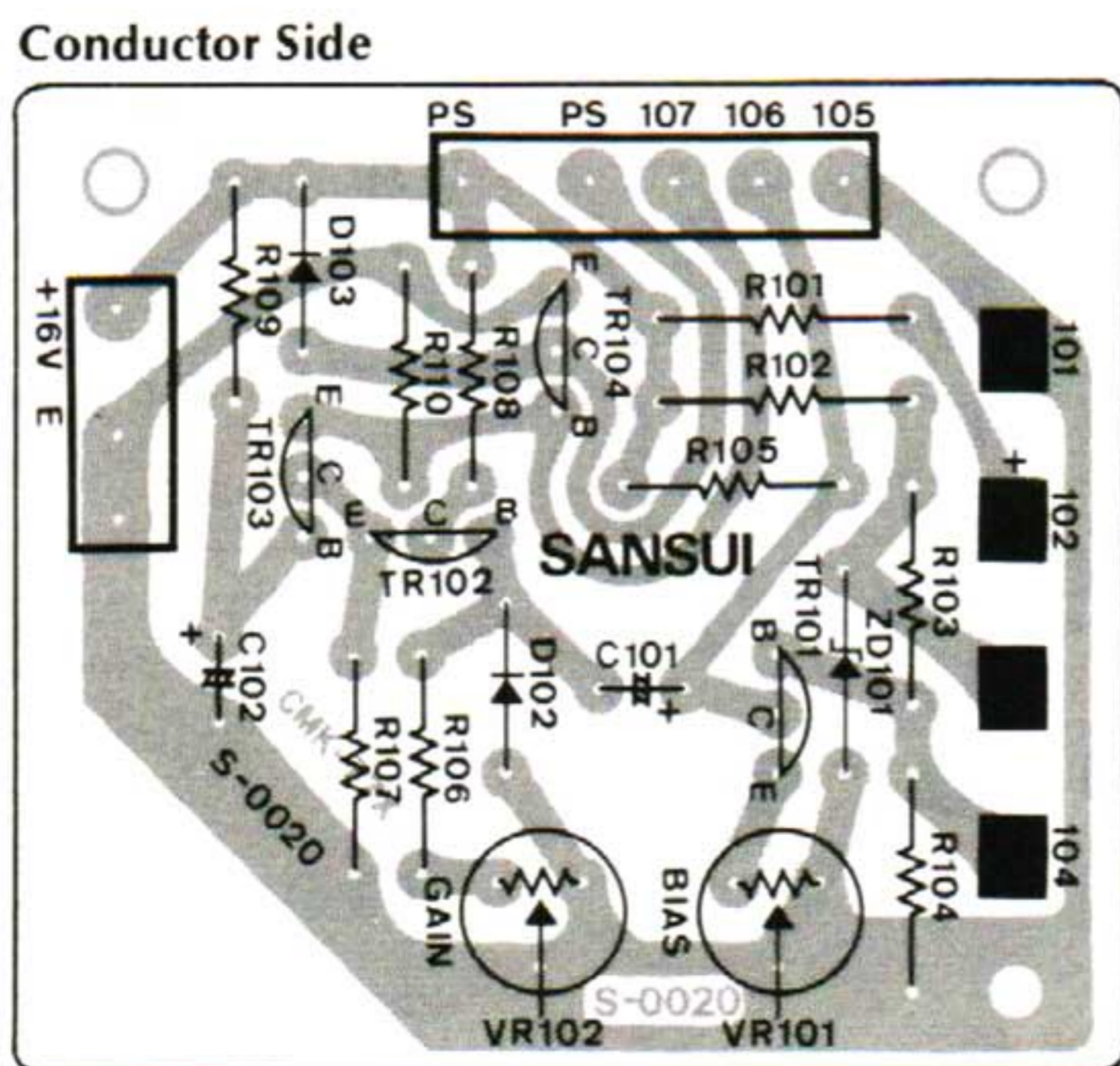

Parts List

| Parts No. | Stock No. | Description |
|-------------|------------|------------------------|
| TR101 ~ 103 | 0305951, 2 | 2SC945 Q, P Transistor |
| TR104 | 0308591, 2 | 2SD471 L, K Transistor |
| D 102 | 0311050 | 1S953 Diode |
| D 103 | 0310340 | 10D1 (1S2226) Diode |
| ZD101 | 0316250 | RD-10E B Zener Diode |
| C 101 | 0573100 | 35V 10μF |
| R101 ~ 102 | 0103681 | 680Ω ½W |
| VR101 | 1035040 | 330Ω (B) |
| VR102 | 1035200 | 150kΩ (B) |
| | 2410570 | 5P Pin Ass'y Type D |
| | 2410580 | 3P Pin Ass'y Type D |

5) S-0018 LED Circuit Board (Stock No. 7595621/SR-737) (Stock No. 7595961/SR7090)

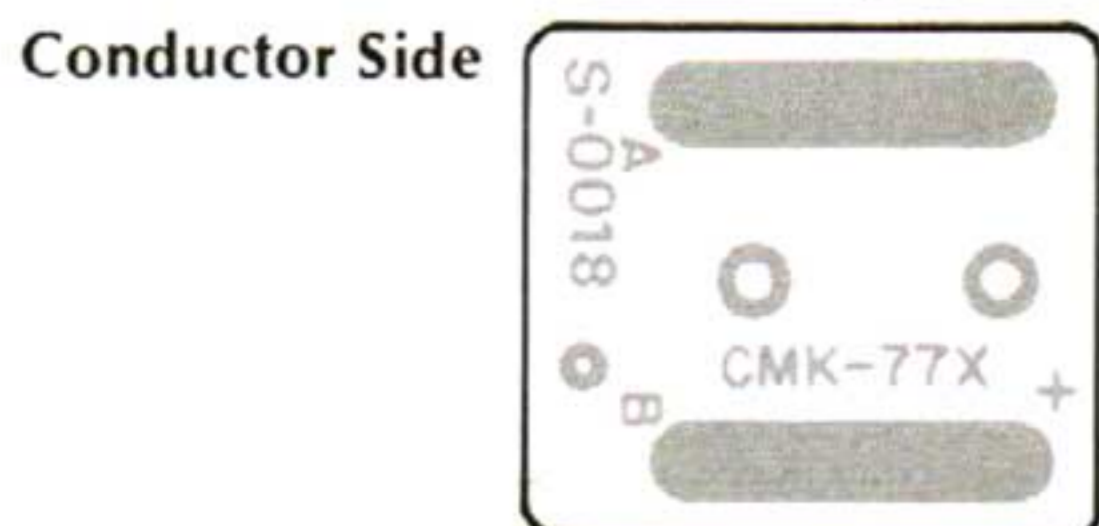

Parts List

| Parts No. | Stock No. | Description |
|-----------|-----------|-------------|
| LD01 | 0319140 | SR-106C LED |

6) S-0019 C D S Circuit Board (Stock No. 7595601/SR-737) (Stock No. 7595951/SS-7090)

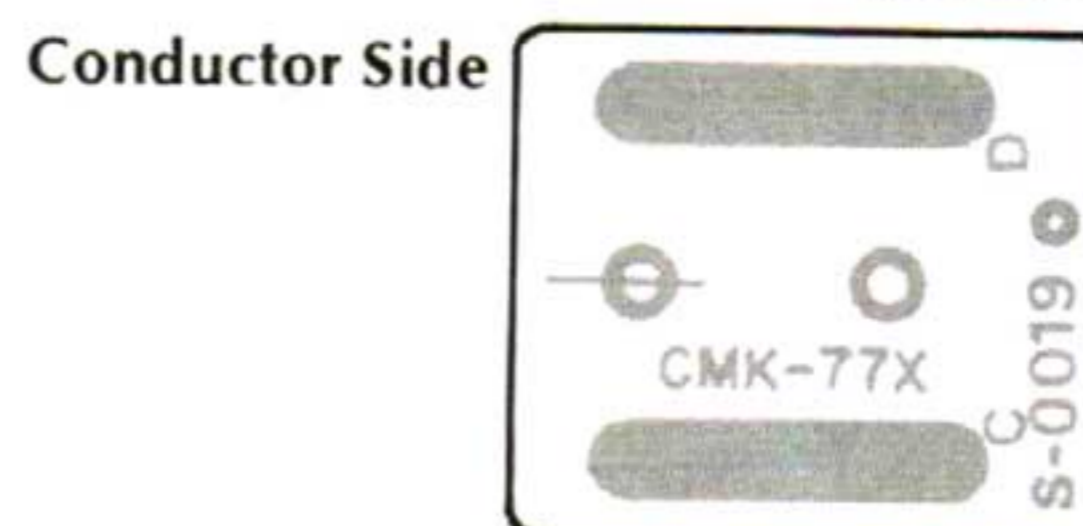

Parts List

| Parts No. | Stock No. | Description |
|-----------|-----------|---------------------------|
| CD01 | 0920070 | P380-05 cds 25 ~ 60kΩ cds |

7) V.G Servo Circuit Board (SR-535/SR-5090)

Note: Complete V.G Servo printed circuit board will not be supplied due to an assembly board with D.D motor. When necessary, order D.D motor (Stock No. 4320480) which contains complete V.G Servo printed circuit board. But, individual parts on V.G Servo printed circuit board will be supplied to your order.

Conductor Side

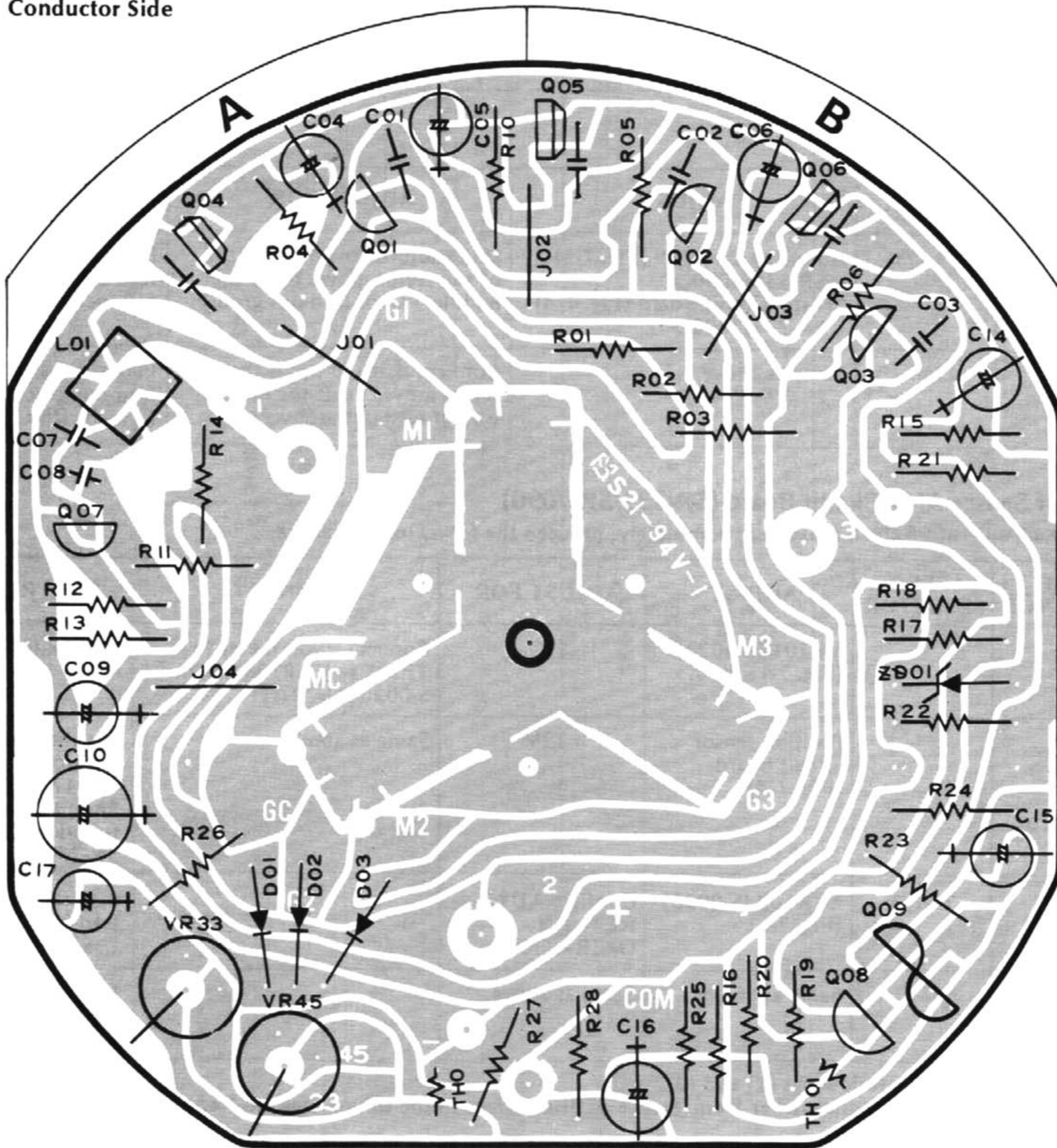

Parts List

| Parts No. | Stock No. | Description | Position | Parts No. | Stock No. | Description | Position | Parts No. | Stock No. | Description | Position |
|-----------|---------------|-------------------------------|----------|-----------|-----------|--------------------|----------|-----------|---------------|-----------------|----------|
| Q 01 ~ 03 | 0300680, 1 | 2SA733 (P, Q) | A, B | TH01, 02 | 0320140 | SDT-100 Thermistor | A, B | R 25 | 0240912 | 9.1 kΩ ¼W C.R. | |
| Q 04 ~ 06 | 0308590, 1, 2 | 2SD471 (M, L, K) | | C 01 ~ 03 | 0656473 | 0.047 μF 25V C.C. | | L 01 | 4220700 | Oscillator Coil | |
| Q 07, 08 | 0305951, 2, 3 | 2SC945 (Q, P, K) | | C 07 | 0601107 | 0.01 μF 50V M.C. | | | 2420480 | Connector | |
| Q 09 | 0360291, 2 | 2SA798 (G, H) Dual Transistor | B | C 08 | 0601226 | 0.0022 μF 50V M.C. | A | 2230170 | Chip Terminal | | |
| ZD01 | 0316630 | RD5.1E Zener Diode | B | R 10 | 0200229 | 2.2Ω ¼W N.I.R. | A | | | | |
| D 01 ~ 03 | 0311180 | 1S1588 Diode | A | R 20 | 0240911 | 910Ω ¼W C.R. | | | | | |

Abbreviations

| | | |
|-----------------------------------|--|-------------------------------------|
| C.R. : Carbon Resistor | N.I.R. : Non-Inflammable Resistor | C.C. : Ceramic Capacitor |
| S.R. : Solid Resistor | M.C. : Mylar Capacitor | Mi.C. : Mica Capacitor |
| Ce.R. : Cement Resistor | E.C. : Electrolytic Capacitor | O.C. : Oil Capacitor |
| M.R. : Metal Film Resistor | BP.E.C. : Bi-Polar Electrolytic Capacitor | P.C. : Polystyrene Capacitor |
| F.R. : Fusing Resistor | | T.C. : Tantalum Capacitor |

8) S-0015 Power Supply Circuit Board

(Stock No. 7502521 XX, 7502523 EU,
7502524 CSA, 7502528 UL, 7502529 BS/SR-535)
(Stock No. 7502721/SR-5090)

Conductor Side

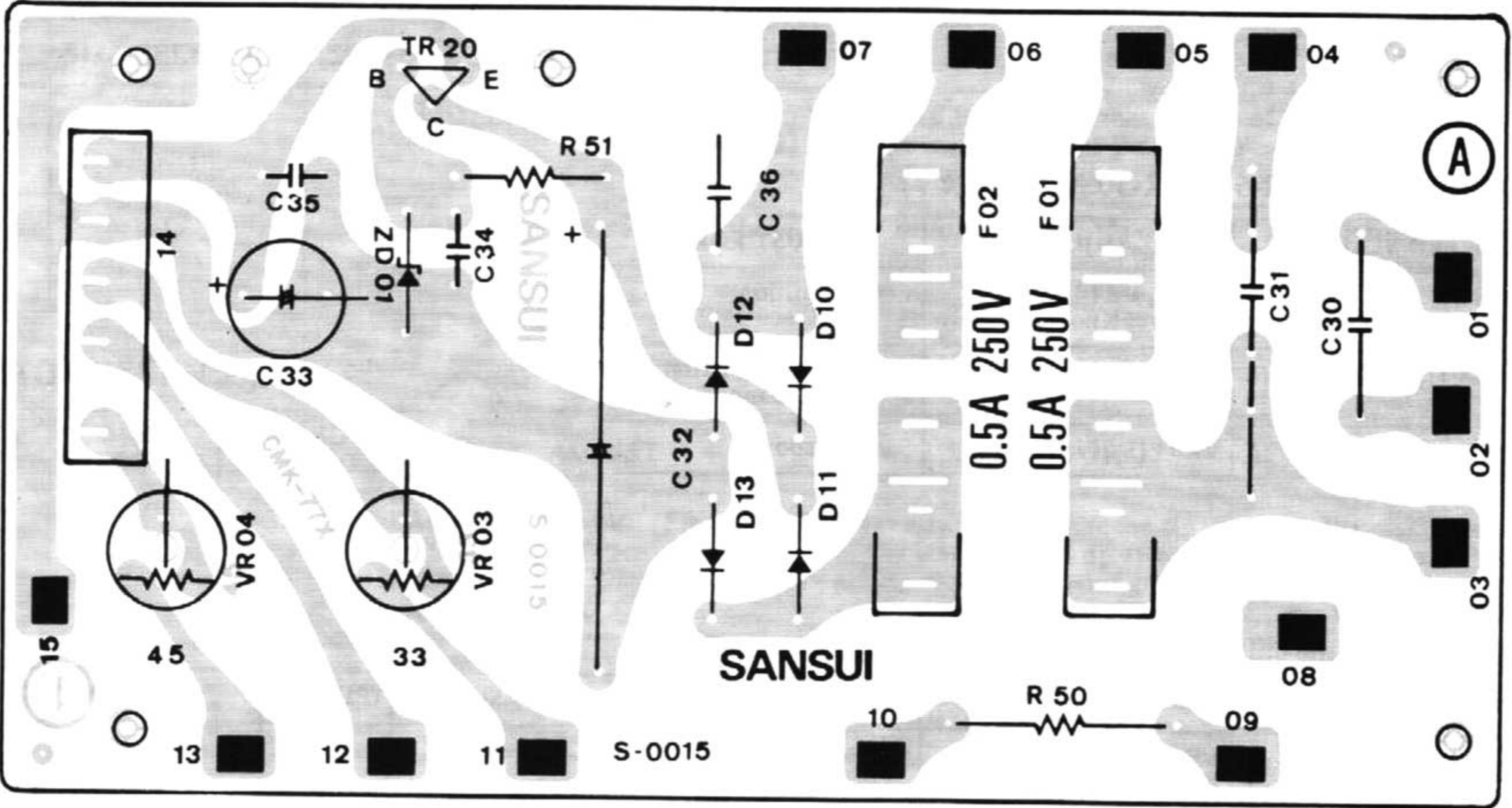

Parts List

| Parts No. | Stock No. | Description | Parts No. | Stock No. | Description | Parts No. | Stock No. | Description |
|-----------|---------------|-----------------------------|-----------|-----------|--------------------------------------|-----------|-----------|---|
| TR 20 | 0308391, 2, 3 | 2SD313 (D, E, F) Transistor | C 34 | 0656473 | 47,000pF 25V C.C. | F 01, 02 | 0432210 | AC Fuse 0.5A 250V ... UL, C.S.A., XX |
| D 10 ~ 13 | 0310340 | 10D1 (1S2226) Diode | C 36 | 0602108 | 0.1μF 100V M.C. | F 02 | 0435060 | Time-Lag Fuse 400mA 250V ... BS, EU |
| ZD01 | 0315380 | RD-19AM Zener Diode | R 50 | 0211123 | 12kΩ 1W N.I.L. ... UL, C.S.A., XX | | 2310220 | Fuse Holder (Large) XX, C.S.A., UL |
| C 30, 31 | 0598337 | 0.033μF 250V M.C. EU, BS | | 0211333 | 33kΩ 1W N.I.L. ... BS, EU | | 2410570 | 5P Pin Ass'y Type D |
| C 31 | 0603337 | 0.033μF 125V M.C. UL | VR03, 04 | 1035130 | 10kΩ (B), Semi-variable Resistor | | | |
| | 0635337 | 0.033μF 125V P.C. C.S.A. | | | | | | |
| | 0605337 | 0.033μF 250V M.C. XX | | | | | | |
| C 32 | 0505331 | 330μF 50V E.C. | | | | | | |

9) S-0012 Circuit Board for connections between P.U output cord & color wires from cartridge

(Stock No. 2593661 SR-535/SR-5090/SR-737/SR-7090)

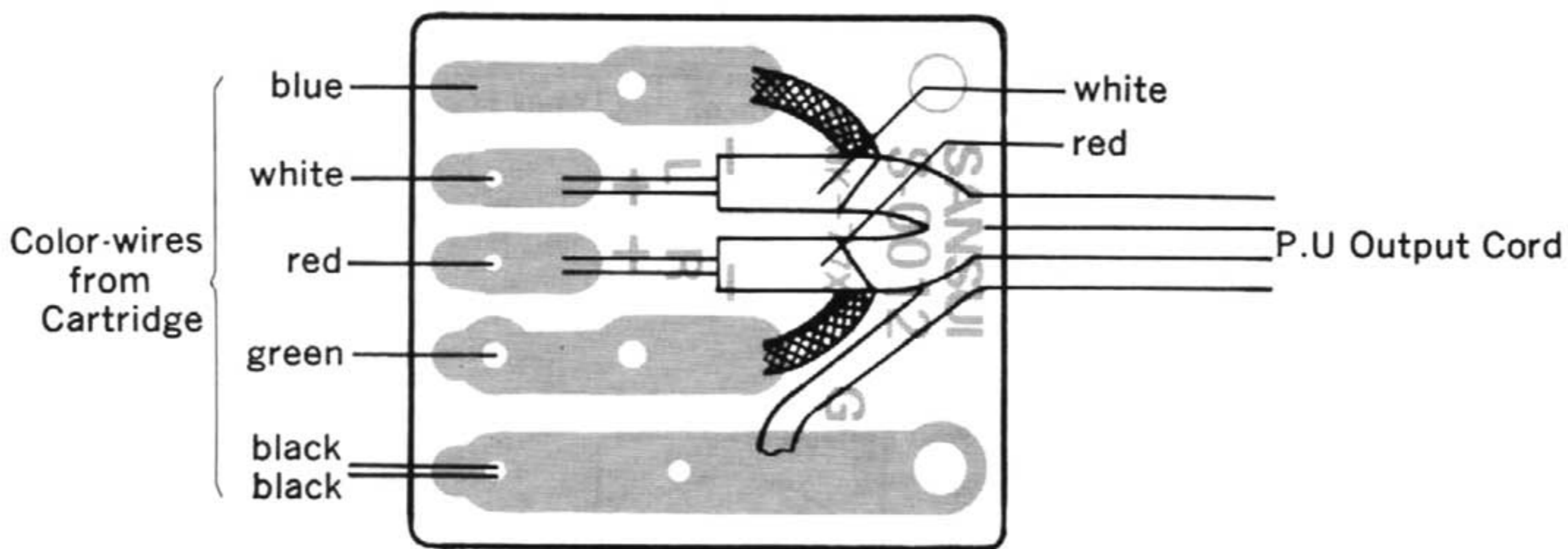

NOTE:

AS to U.L., C.S.A., B.S., ES and XX marked in the Parts Lists, note the followings:
 U.L., C.S.A. Approved parts used in the unit which is applicable to the U.S. and Canada under safety standard.
 B.S. Approved parts used in the unit which is applicable to British under safety requirement.
 E.U. Approved parts used in the unit which is applicable to Sweden, Denmark, Norway, Finland, West Germany, and Switzerland under safety requirement.
 XX Parts used in the unit which is applicable to other countries excepting mentioned above.

* Parts unspecified such as CSA, UL, EU & XX in "Description" are common parts.

7. ADJUSTMENTS

1. Speed adj

1) SR-535/SR-5090

(See Bottom View SR-535/SR-5090 on page 7)

| STEP | SPEED SELECTOR | ADJUST | ADJUST FOR |
|------|----------------|---------------------------------------|--|
| 1 | 33-1/3 | VR13, VR14 (Control Knob on Panel) | Center position. |
| 2 | 33-1/3 | VR03 (S-0015) | Strobo marking pattern appears to stand still. |
| 3 | 45 | VR04 (S-0015) | Same as above. |

2) SR-737/SR-7090

For adjustment, set the unit horizontally and attach the turntable platter.

| STEP | SPEED SELECTOR | ADJUST | ADJUST FOR | MEASURE OUTPUT | REMARKS |
|------|----------------|---|---|--|--|
| 1 | 33-1/3 | VR733, VR745 (Control Knob on panel) | Center position | | |
| 2 | 33-1/3 | VR73 (S-0014) | 1.25V | Connect a volt meter (20 k Ω /V) to D terminal on S-0013 (Fig. 7-1) | Make short between TP Pin (S-0014) & chassis. (Fig. 7-1) After adjustment, disconnect the volt meter (20 k Ω /V) |
| 3 | 33-1/3 | VR33 (S-0013) | Strobo marking pattern appears to stand still. | | Same as above. |
| 4 | 45 | VR45 (S-0013) | Same as above. | | Same as above. After this adjustment, disconnect the shorting lead between TP Pin & chassis. |
| 5 | 33-1/3 | VR73 (S-0014) | 1.25V | Connect a volt meter (20 k Ω /V) to D terminal on S-0013 (Fig. 7-1) | Stop the rotation of turntable pressing down the platter. After adjustment, disconnect the volt meter (20 k Ω /V) |
| 6 | 33-1/3 | VR72 (S-0014) | Strobo marking pattern appears to stand still. | Connect oscilloscope as Fig. 7-1. | |
| 7 | 33-1/3 | VR33 (S-0013) | Set the waveform on oscilloscope to adjusted one as Fig. 7-2. | Same as above. | |
| 8 | 45 | VR71 (S-0014) | Strobo marking pattern appears to stand still. | Same as above. | |
| 9 | 45 | VR45 (S-0013) | Set the waveform on oscilloscope to adjusted one as Fig. 7-2. | Same as above. | |

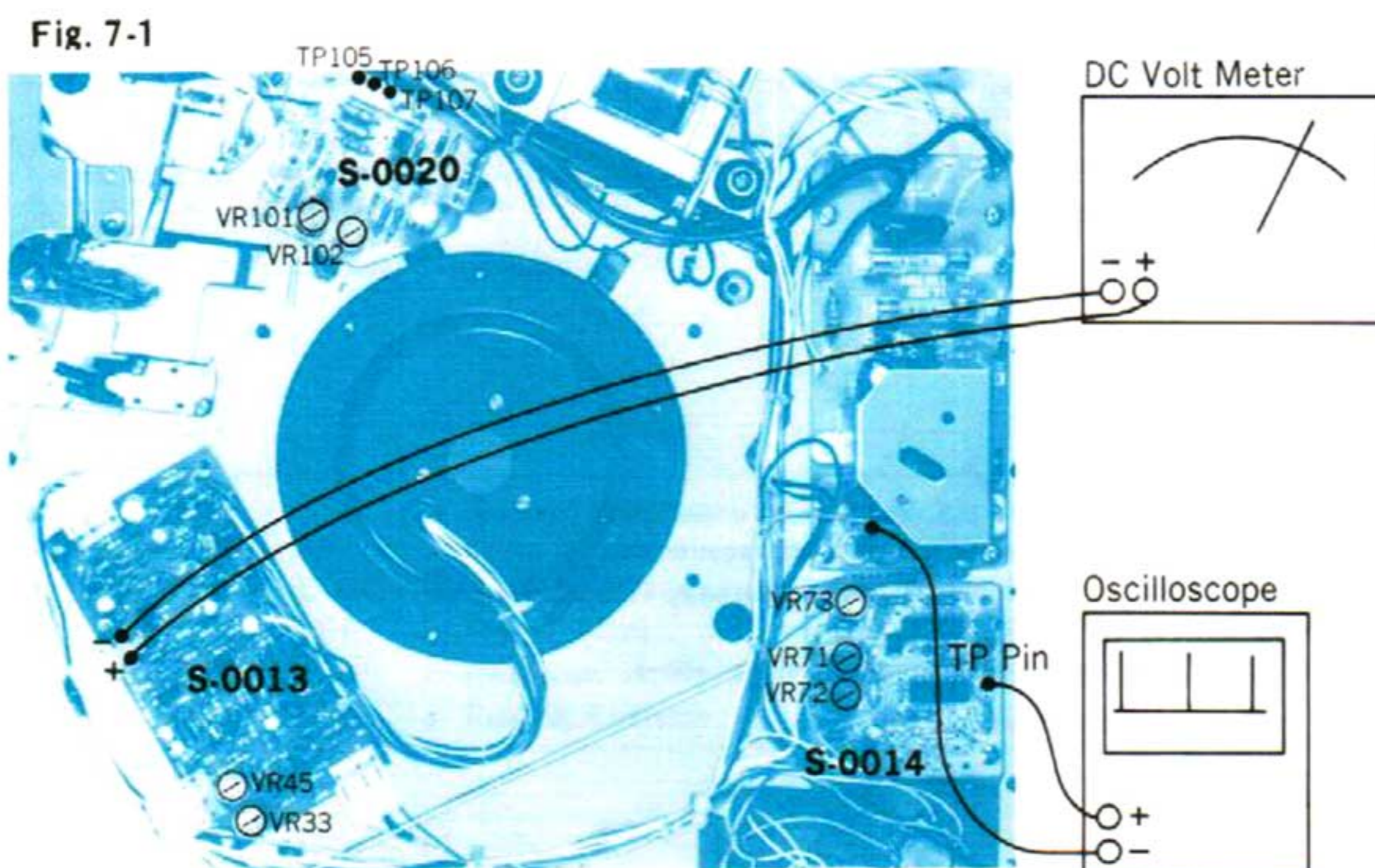
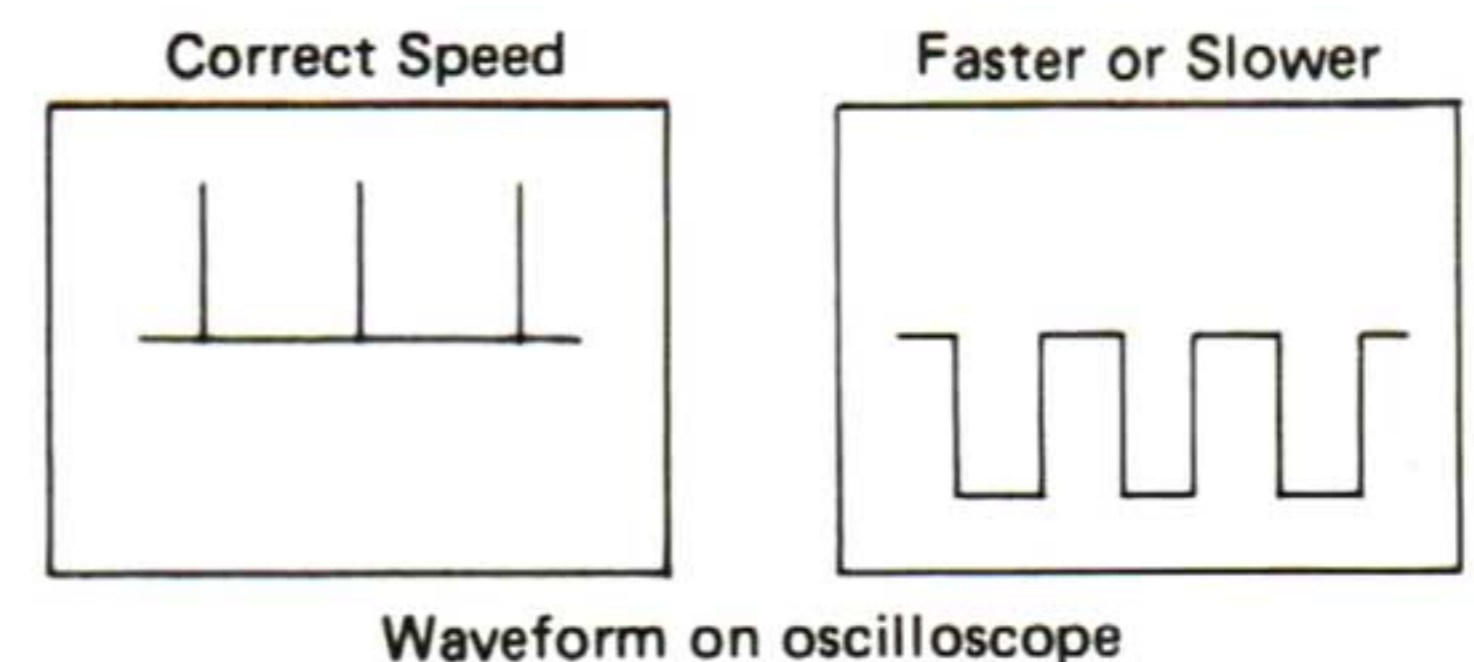

Fig. 7-2



2. Adjustments of AUTO-IN and AUTO-RETURN

1) AUTO-IN adj.

| STEP | SIZE SELECTOR | SPEED SELECTOR | ADJUST | ADJUST FOR | REMARKS |
|------|---------------|----------------|------------------------------|--|--|
| 1 | 30 | 33-1/3 | Adjusting cam "A" (Fig. 7-3) | Make adjustment that the tip of the stylus touches the middle way of the lead-in groove. | Play the disk that has short lead-in groove. Use 30 cm (12 inch) Disk. |
| 2 | 17 | 45 | Same as above. | Confirm that the tip of the stylus touches the middle way of the lead-in groove. | Play the disk that has short lead-in groove. Use 17 cm (7 inch) Disk. |

2) AUTO-RETURN adj.

| STEP | SIZE SELECTOR | SPEED SELECTOR | ADJUST | ADJUST FOR | REMARKS |
|------|---------------|----------------|---|---|---|
| 1 | 30 | 33-1/3 | Adjusting cam "B" (Fig. 7-3) <SR-535/5090> Sensor Circuit Board (Fig. 7-4) <SR-737/7090> | Make adjustment that the tip of the stylus moves up at the middle way of lead-out groove. | Play the disk that has short lead-out groove. Use 30 cm (12 inch) Disk. |
| 2 | 17 | 45 | Same as above. | Confirm that the tip of the stylus moves up at the middle way of lead-out groove. | Play the disk that has short lead-out groove. Use 17 cm (7 inch) Disk. |

3) Adjustment of Sensor AMP Circuit Board (SR-737/SR-7090)

Note: If unable to adjust Auto-Return movement completely, proceed the following procedure.

| STEP | SIZE SELECTOR | SPEED SELECTOR | ADJUST | ADJUST FOR | CONNECT | REMARKS |
|------|---------------|----------------|--|-------------------------------|---|---|
| 1 | | | VR101 (S-0020) (Fig. 7-1) | 1V | Connect a volt meter to TP105 (-), TP106 (+) on S-0020 (Fig. 7-1) | Put the tone arm on the arm rest. |
| 2 | | | Position sensor circuit board (Fig. 7-4) | 13V | Same as above. | Put the stylus on the finishing groove of disk. Use 17 cm (7 inch) Disk. Shim the plunger not to function. (See Bottom View SR-737/SR-7090 on page 7) |
| 3 | 30 | 33-1/3 | *VR102 (S-0020) (Fig. 7-1) | Confirm AUTO-RETURN OPERATION | | Play the disk that has short lead-out groove. Use 30 cm (12 inch) Disk. |
| 4 | 17 | 45 | Same as above. | Same as above. | | Play the disk that has short lead-out groove. Use 17 cm (7 inch) Disk. |

* Do not turn VR102 except the followings (1) and (2).

- (1) If stylus tip would move up too earlier from groove of disk surface in the timing of Auto-Return movement, turn VR102 counter-clockwise.
- (2) If stylus tip would not move up even in finishing groove of disk surface, turn VR102 clockwise.

Fig. 7-3

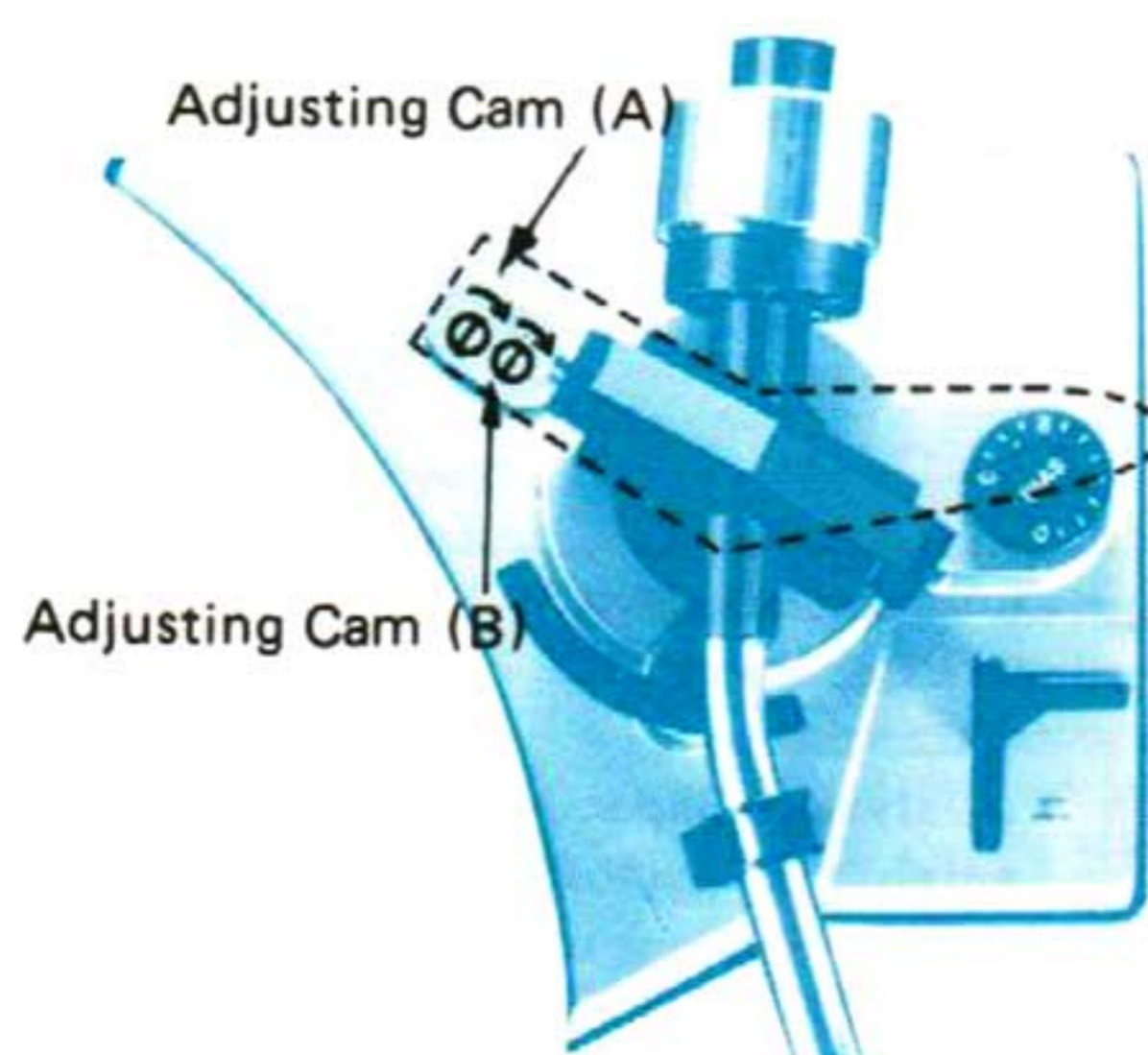

Fig. 7-4

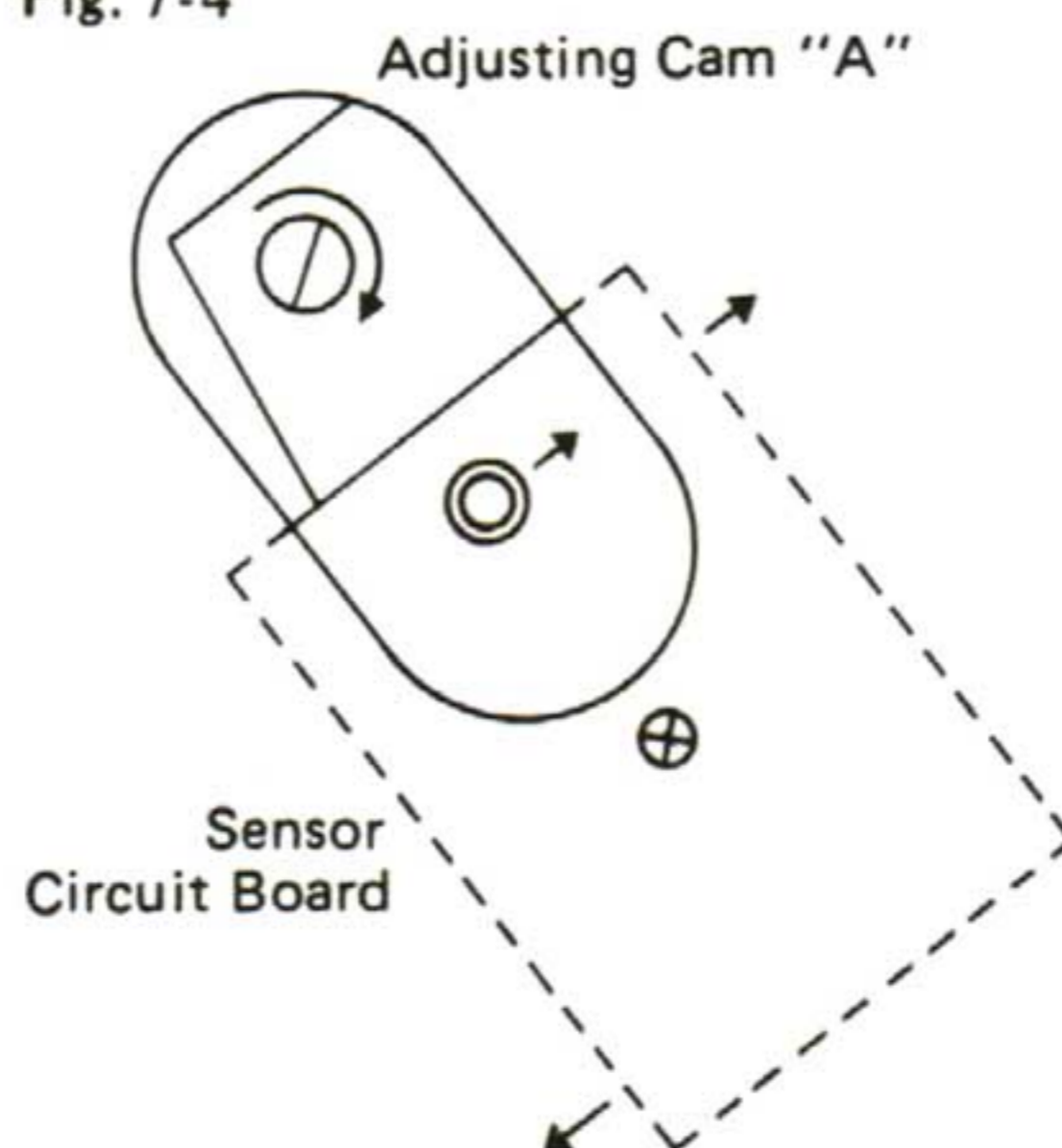
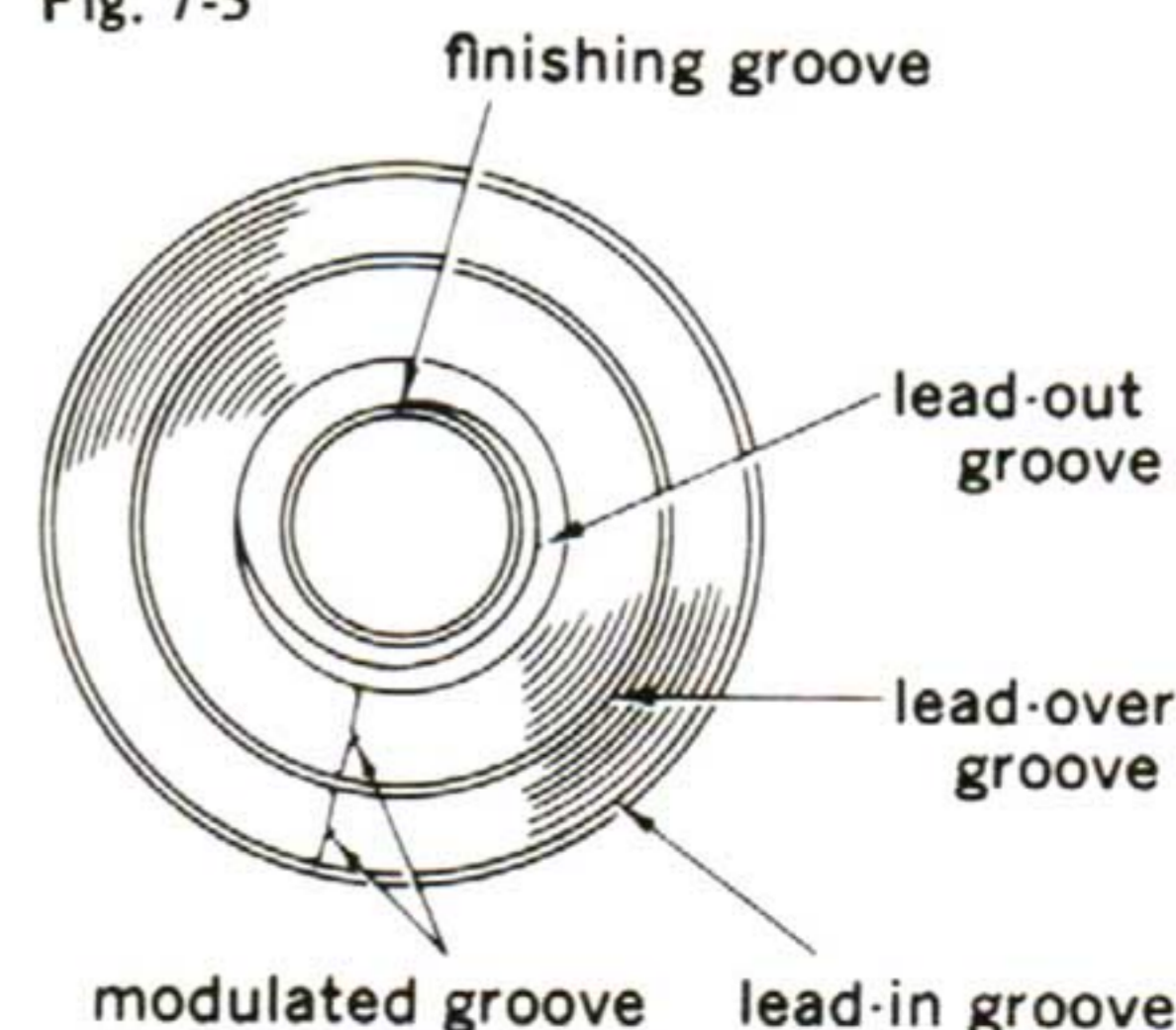


Fig. 7-5



8. SCHEMATIC DIAGRAM 1) SR-737/SR-7090

<SR-737/SR-7090 XX, UL, CS>



9. PACKING LIST

| Parts No. | Stock No. | Description |
|-----------|-----------|--|
| 1 | 9012310 | Upper Sheet |
| 2 | 7012161 | Dust Cover Ass'y |
| 3 | 9122110 | Polyethylene Sheet |
| 4 | 9012270 | Protector Sheet, turntable |
| 5 | 5502901 | Rubber Mat. XX, UL (SR-5090, SR-7090) |
| | 5502891 | Rubber Mat. EU, CSA, BS |
| 6 | 6112183 | Turntable (Platter) (SR-535, SR-5090) |
| | 6112191 | Turntable (Platter) (SR-737, SR-7090) |
| 7 | 9116600 | Polyethylene Bag, turntable |
| 8 | 9112250 | Polyethylene Bag, turntable unit |
| 9 | 9082071 | Stylofoam Packing, front |
| 10 | 9082081 | Stylofoam Packing, back |
| 11 | 9022630 | Accessories Package |
| 12 | 9082110 | Plastic Cover Sheet |
| 13 | 9002650 | Carton Case (SR-535) |
| | 9002730 | Carton Case (SR-5090) |
| | 9002670 | Carton Case (SR-737) |
| | 9002740 | Carton Case (SR-7090) |
| 14 | 5996080 | Curl Stopper |

10. ACCESSORY PARTS LIST

| Stock No. | Description |
|-----------|------------------------------------|
| 9203070 | Operating Instruction (SR-535) |
| 9203080 | Operating Instruction (SR-5090) |
| 9203090 | Operating Instruction (SR-737) |
| 9203100 | Operating Instruction (SR-7090) |
| 9232160 | Schematic Diagram XX (SR-535) |
| 9232190 | Schematic Diagram (SR-5090) |
| 9232170 | Schematic Diagram XX (SR-737) |
| 9232200 | Schematic Diagram (SR-7090) |
| 5242590 | Cartridge Mounting Gauge |

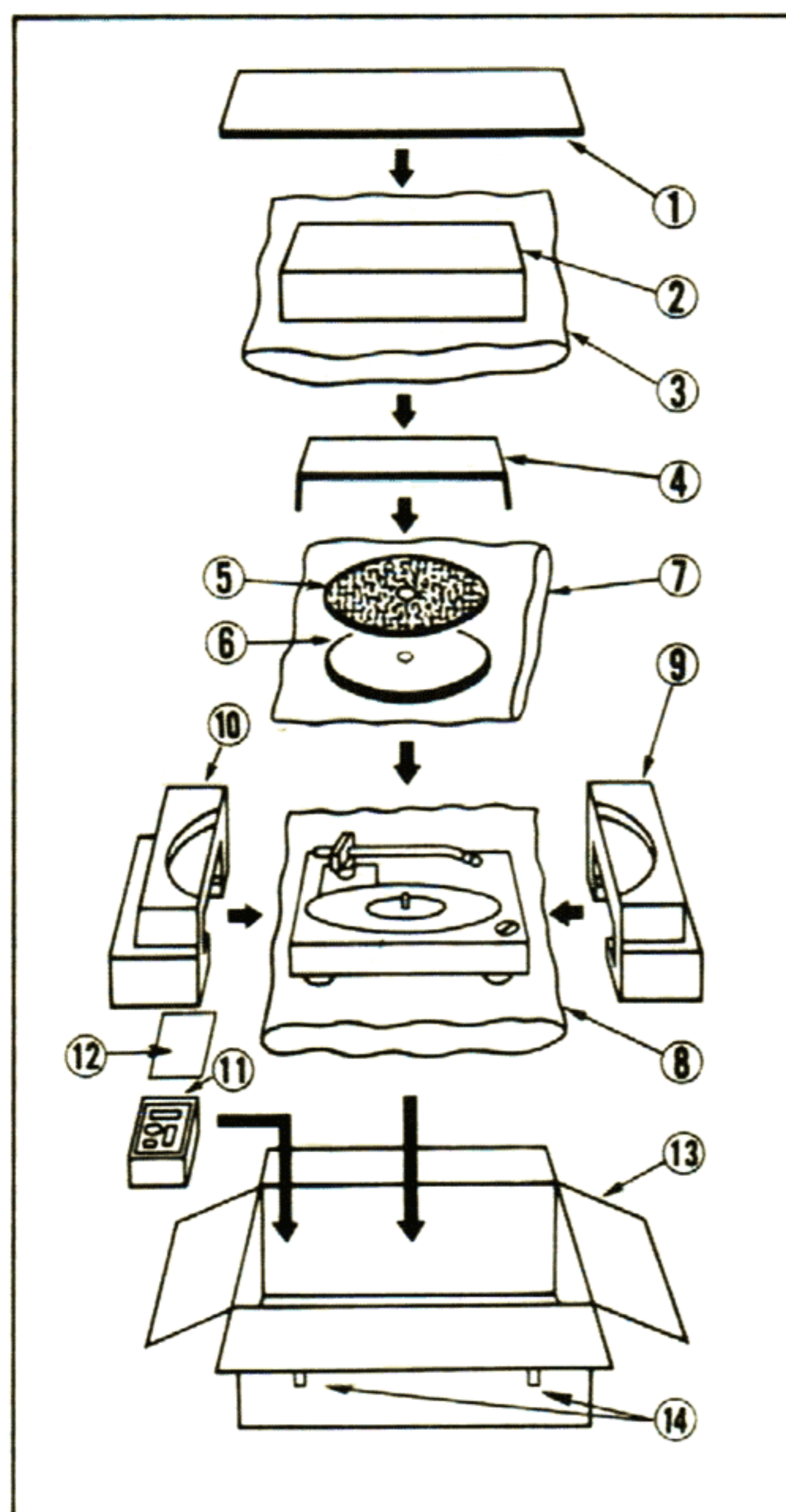

SANSUI ELECTRONICS CORPORATION : 55-11 Queens Blvd. Woodside, N.Y. 11377 U.S.A.
333 West Alondra Blvd. Gardena, California 90247 U.S.A.
3036 Koapaka St. Honolulu, Hawaii 96819 U.S.A.

SANSUI AUDIO EUROPE N.W. : North Trade Bldg (9th floor) Noorderlaan 133-Bus 1,2030 Antwerp, Belgium
SANSUI AUDIO EUROPE S.A. : Ababella center, 6 Frankfurt AM Main, Lyoner Strasse 44-48, West Germany

SANSUI ELECTRIC COMPANY LTD. : 14-1, Izumi 2-chome, Suginamiku, Tokyo 168 Japan PHONE: (03) 323-1111/TELEX:232-2076