

SERVICE MANUAL

QUARTZ SYNTHESIZER STEREO RECEIVER

SANSUI S-X700/X500



CAUTION

1. Parts identified by the \triangle symbol on the schematic diagram and the parts list are critical for safety. Use only replacement parts that have critical characteristics recommended by the manufacturer.
2. Make leakage-current or resistance measurements to determine that exposed parts are acceptably insulated from the supply circuit before returning the appliance to the customer.

•SPECIFICATIONS

S-X700

Audio section

Power output

Min. RMS, both channels driven, from 20 to 20,000 Hz with no more than 0.08% total harmonic distortion
43 watts per channel into 8 ohms

Total harmonic distortion

..... less than 0.08% at or below
rated min. RMS power output

Load impedance

..... 4 ~ 16 ohms

Input sensitivity and impedance (1 kHz)

PHONO 2.5 mV/47 kohms

CD, TAPE PLAY 150 mV/47 kohms

Frequency response (at 1 watt)

..... 10 to 70,000 Hz,

+1 dB, -3 dB

Signal to noise ratio (short-circuit, A-network)

PHONO 73 dB

CD, TAPE PLAY 95 dB

FM section

Tuning range 88 to 108 MHz

Usable sensitivity

Mono IHF 10.8 dBf (1.9 μ V: T-100)

50 dB quieting sensitivity

Stereo 37 dBf

Signal to noise ratio (at 65 dBf)

Stereo 70 dB

Distortion (at 65 dBf)

Stereo less than 0.2% at 1,000 Hz

Stereo separation 40 dB at 1,000 Hz

AM section

Tuning range 530 to 1,600 kHz

Usable sensitivity (Loop antenna)

..... 52 dB/m (398 μ V/m)

Signal to noise ratio 45 dB

Others

Power requirements 120/220/240V

50/60 Hz

For U.S.A. and Canada

..... 120V (60 Hz)

Power consumption 280 watts 330 VA Rated

420 watts Maximum

Dimensions 430 mm (16-15/16") W

114 mm (4-1/2") H

362 mm (14-1/4") D

Weight 8.2 kg (18.0 lbs) net

9.7 kg (21.4 lbs) packed

to be continued ►

Sansui

SANSUI ELECTRIC CO., LTD.

S-X500**Audio section****Power output**

Min. RMS, both channels driven, from 30 to 20,000 Hz with no more than 0.2% total harmonic distortion
30 watts per channel into 8 ohms

Total harmonic distortion

..... less than 0.2% at or below
rated min. RMS power output

Load impedance 4~16 ohms

Input sensitivity and impedance (1 kHz)

PHONO 2.5 mV/47 kohms

CD, TAPE PLAY 150 mV/47 kohms

Frequency response (at 1 watt)

..... 10 to 70,000 Hz,
+1 dB, -3 dB

Signal to noise ratio (short-circuit, A-network)

PHONO 73 dB

CD, TAPE PLAY 95 dB

FM section

Tuning range 88 to 108 MHz

Usable sensitivity

Mono IHF 10.8 dBf (1.9 μ V: T-100)

50 dB quieting sensitivity

Stereo 37 dBf

Signal to noise ratio (at 65 dBf)

Stereo 70 dB

Distortion (at 65 dBf)

Stereo less than 0.2% at 1,000 Hz

Stereo separation 40 dB at 1,000 Hz

AM section

Tuning range 530 to 1,600 kHz

Usable sensitivity (Loop antenna)

..... 52 dB/m (398 μ V/m)

Signal to noise ratio 45 dB

Others

Power requirements 120/220/240V
50/60 Hz

For U.S.A. and Canada

..... 120V (60 Hz)

Power consumption 190 watts 220 VA Rated

280 watts Maximum

Dimensions 430 mm (16-15/16") W

114 mm (4-1/2") H

362 mm (14-1/4") D

Weight 7.4 kg (16.3 lbs) net

8.6 kg (19.0 lbs) packed

* Design and specifications subject to changes without notice for improvements.

* Due to local laws and regulations, this unit sold in some areas are not equipped with variable voltage selectors

CAUTION

1. The symbols, UL, CSA, SA, BS, UK, EU, AS, SEV and XX (EXPORT) on the parts list and the schematic diagram mean followings respectively.

UL Manufactured for U.S.A market.
(Underwriters Laboratories approved model.)

CSA Manufactured for Canadian market.

SA Manufactured for South African market.

BS, UK Manufactured for United Kingdom market.

EU Manufactured for European market.

AS Manufactured for Australian market.

SEV Manufactured for Swiss market.

XX (EXPORT).. Standard Version.

NON MARK..... Common Parts.

2. Some printed circuit boards are not supplied assembled.

To separate these in this service manual, the stock numbers are not indicated for these boards. However, stock numbers for individual parts are indicated.

3. Since some capacitors and resistors are omitted from parts lists in this service manual, refer to the Common Parts List for capacitors & resistors, which was issued on February 1983.

4. Abbreviations in this service manual are as follows.

•Abbreviations List

C.R.	: Carbon Resistor
S.R.	: Solid Resistor
W.R.	: Wire Wound Resistor
M.R.	: Metal Film Resistor
F.R.	: Fusing Resistor
N.I.R.	: Non-Inflammable Resistor
R.A.	: Resistor Array
C.C.	: Ceramic Capacitor
C.T.	: Ceramic Capacitor, Temperature Compensation
E.C.	: Electrolytic Capacitor
E.L.	: Low Leakage Electrolytic Capacitor
E.B.	: Bi-Polar Electrolytic Capacitor
E.B.L.	: Low Leakage Bi-Polar Electrolytic Capacitor
Ta.C.	: Tantalum Capacitor
F.C.	: Film Capacitor
M.P.	: Metallized Paper Capacitor
P.C.	: Polystyrene Capacitor
C.A.	: Capacitor Array
V.R.	: Variable Resistor
SW.	: Switch
Chip R.	: Chip Resistor
Chip C.	: Chip Capacitor

1. BLOCK DIAGRAM

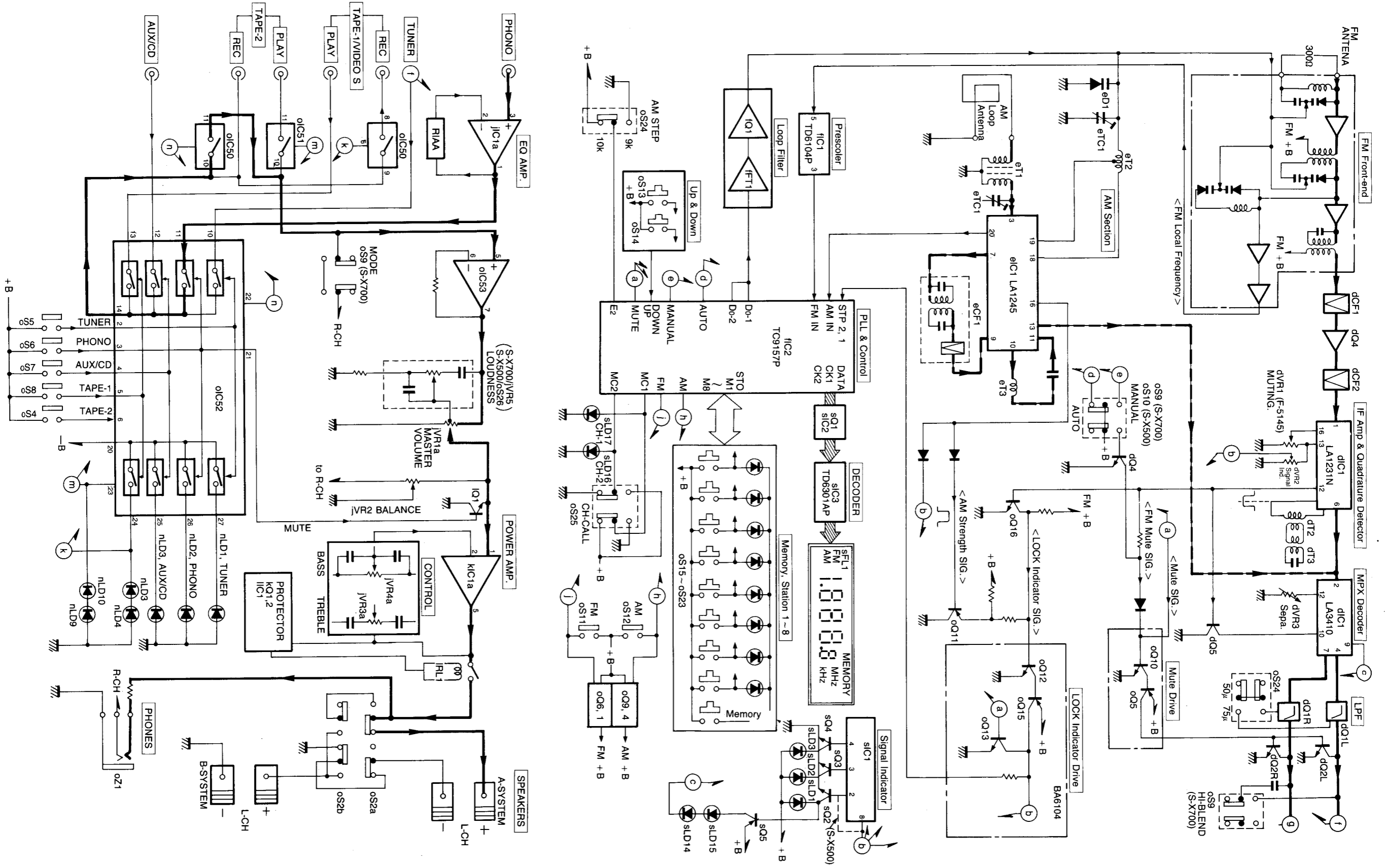

2. ADJUSTMENTS

2-1. FM Adjustment (See Fig. 2-1)

Fig. 2-1

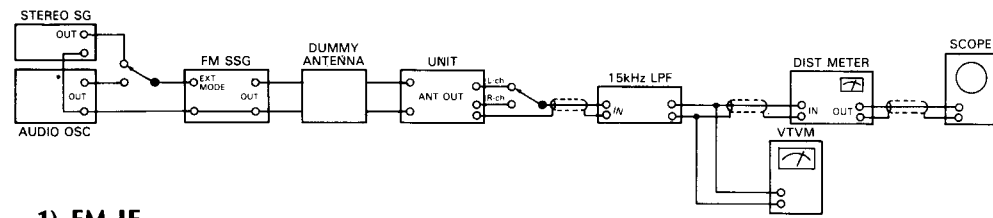
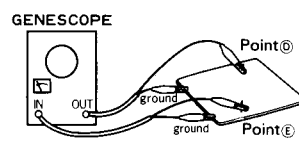

Fig. 2-2



1) FM IF

Note: 1. SELECTOR FM
2. FM MUTING/MODE OFF/MONO

STEP	SUBJECT	FEED SIGNAL		MEASURE OUTPUT	ADJUST	ADJUST FOR	REMARKS	
		FROM	TO					
1.	IF Coil Adj.	98MHz ANT Input 20dBf (14.8dB), 1kHz (100% MOD.), FM SSG	ANT terminal 300Ω	Between Point B (Pin 13 of dIC2) & Earth (F-4853), DC Volt Meter	IFT Coil (Front-end, F-5415)	Max. DC Volt		
2.	Discriminator Coil Adj. In case of using Genescope	1	No Input	Between Point B (Pin 7 of dIC1) & Point C (Pin 10 of dIC1) (F-4853), DC Volt Meter	dT2 (F-4853)	DC 0V ± 30mV	•Repeat procedures as stated in subject 1 & 2.	
		2	Output 80dB, Genescope	Point E (dCF1)	Between Point E (Pin 6 of dIC1) & Earth (F-4853)	dT3 (F-4853)		Steep linearity of S curve. Make symmetrical S curve.
	Discriminator Coil Adj. In case of using Dist meter	1	98MHz ANT Input 65dBf (59.8dB), No MOD., FM SSG	ANT terminal 300Ω	Between Point B (Pin 7 of dIC1) & Point C (Pin 10 of dIC1) (F-4853), DC Volt Meter	dT2 (F-4853)	DC 0V ± 30mV	•Repeat procedures as stated in subject 1 & 2. •Since the IFT Coil has already adjusted, perform only a fine adjustment in this procedure.
		2	98MHz ANT Input 65dBf (59.8dB), 1kHz (100% MOD.), FM SSG	Same as above	•REC OUT L-CH or R-CH Dist Meter & SCOPE	dT3 (F-4853)	Min. THD	
3.	Signal Level Adj. <S-X700 only>	98MHz ANT Input 25dBf (19.8dB), 1kHz (100% MOD.), FM SSG	Same as above	•Signal LED	dVR2 (F-5415)	Turns ON first LED		

•ADJUSTMENT FOR FM

There are two kind in indication of FM SSG output attenuator
1. Attenuator with marking of 75Ω open open indication type.
2. Attenuator with marking of 75Ω load or close load or close indication type.
FM SSG output level in this FM adjustment are described as open indication type.
To feed FM signal, a dummy antenna circuit as Fig. 2-3 must be connected between FM SSG output and ANT terminal (300Ω) of the unit.

Fig. 2-3

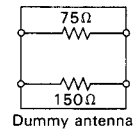

The following table shows relations among FM SG attenuator indication (dB), available power ratio (dBf) and antenna terminal voltage (dB/μV) in each indication type.

	FM SG Attenuator Indication	Available Power Ratio	Antenna Terminal Voltage
Open indication type	0 dB 66 dB	-0.8 dBf 65.2 dBf	-6 dB/μV 60 dB/μV
Load or close indication type	0 dB 60 dB	5.2 dBf 65.2 dBf	0 dB/μV 60 dB/μV

2) FM STEREO

1. FM MODE AUTO

STEP	SUBJECT	FEED SIGNAL		MEASURE OUTPUT	ADJUST	ADJUST FOR	REMARKS
		FROM	TO				
1.	Separation Adj.	98MHz ANT Input 65dBf (59.8dB), FM SSG, Pilot 19kHz (9% MOD.), L MODE 1kHz + Pilot (100% MOD.), STEREO SSG.	ANT terminal 300Ω	REC OUT L-CH AC Volt Meter & SCOPE	—	Read the indication on	Confirm R→L-CH
				REC OUT R-CH AC Volt Meter & SCOPE			
2.	Muting Level Adj.	98MHz ANT Input 25dBf (19.8dB), FM SSG, Pilot 19kHz (9% MOD.), L or R MODE 1kHz + Pilot (100% MOD.), STEREO SSG.	Same as above	Stereo indicator REC OUT L-CH or R-CH. AC Volt Meter & SCOPE	dVR1 (F-5415)	Stereo indicator turns ON or Output Signal comes out	

Fig. 2-4 F-4853 FM IF Amp. Board

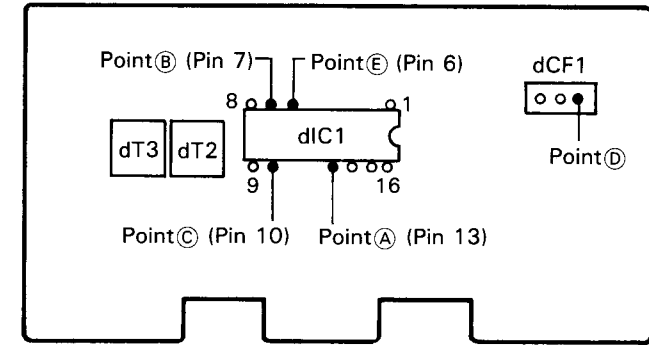
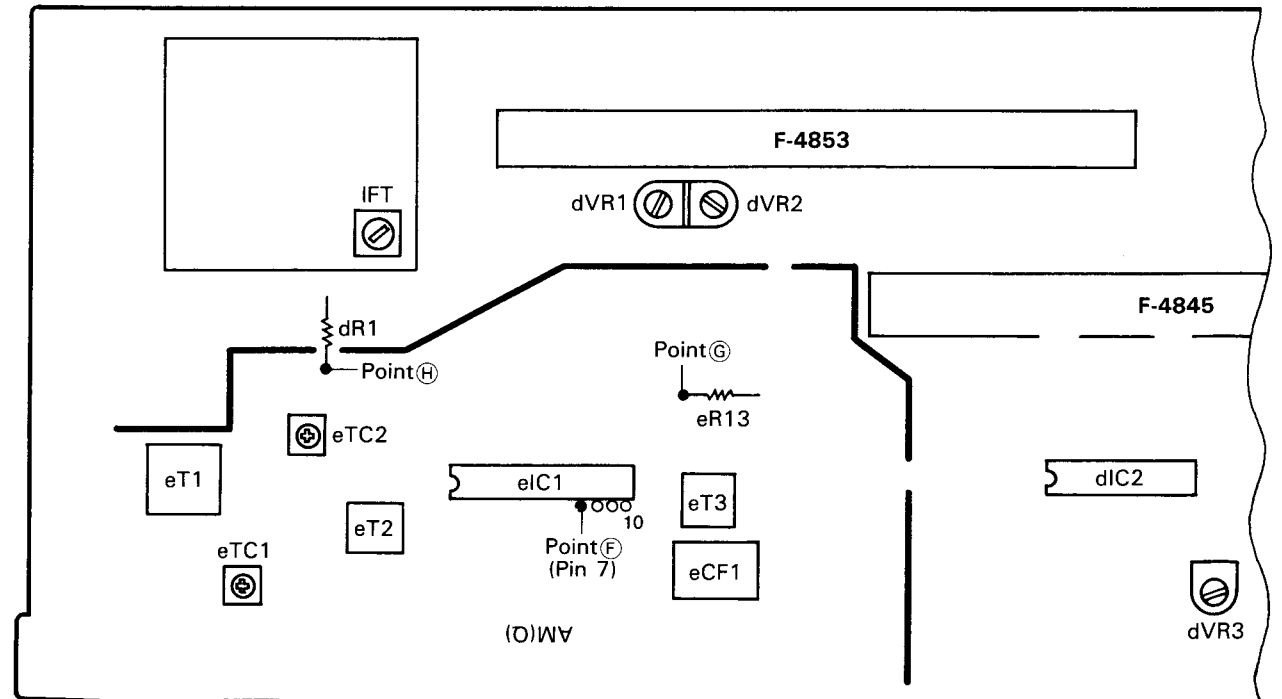
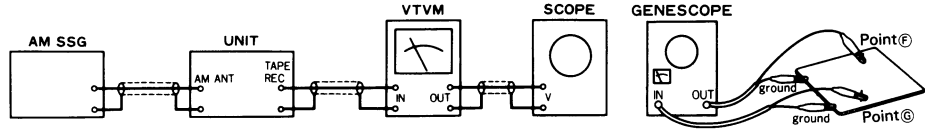

Fig. 2-5



2-2. AM Adjustment

Fig. 2-6



1) AM IF, RF & Tuning

- Note:** 1. SELECTOR..... AM
 2. Connect AM loop antenna AM to antenna terminal.

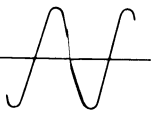
STEP	SUBJECT	FEED SIGNAL		MEASURE OUTPUT	ADJUST	ADJUST FOR	REMARKS
		FROM	TO				
1.	IF Coil Adj.	Genescope Output 80dB	Point ⑥ (Pin No. 7 of eIC1) (F-5415)	Between Point ③ (eR13) & Earth	eCF1, eT3 (F-5415)	Max. Waveform	
2.	531kHz (or 530kHz) Tuning Adj.	No Input	—	Between Point ④ (dR1, F-5415) & Earth DC Volt Meter	eT2 (F-5415)	1V ± 0.1V	•Repeat procedures as stated in subject 2 & 3.
3.	1602kHz (or 1600kHz) Tuning Adj.	No Input	—	Same as above	eTC2 (F-5415)	8V ± 0.1V	
4.	603kHz (or 600kHz) RF Adj.	603kHz (or 600kHz) ANT Input 0dB 400Hz (30% MOD.), AM SSG	ANT terminal	REC OUT L-CH or R-CH VTVM & Scope	eT1 (F-5415)	Max. Output	
5.	1404kHz (or 1400kHz) RF Adj.	1400kHz (or 1400kHz) ANT Input 0dB 400Hz (30% MOD.), AM SSG	Same as above	REC OUT L-CH or R-CH VTVM & Scope	eTC1 (F-5415)	Max. Output	

•Abbreviations

Equipment
 AM FM Generator Oscilloscope..... Genescope
 AM Standard Signal Generator..... AM SSG
 FM Standard Signal Generator FM SSG
 FM Stereo Generator Stereo SG
 Oscilloscope Scope
 Audio Oscillator Audio Osc.
 Distortion Meter Dist. Meter

Others
 Antenna ANT.
 Modulation MOD.
 Total Harmonic Distortion T.H.D.

3. PARTS LOCATION ON BOARD

3-1. F-4759 EQ. Amp. Board

Component Side

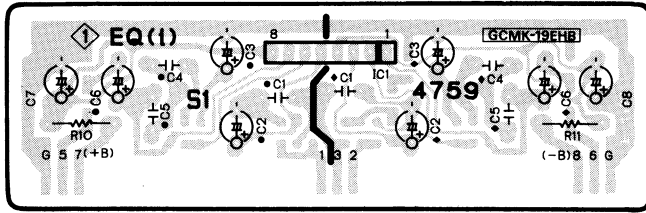

Pattern Side < Chip Parts >

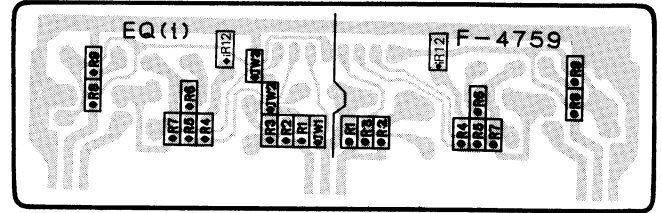

3-2. F-4761 Tone Control Board

Component Side

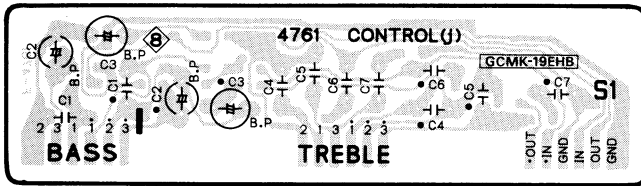

Pattern Side < Chip Parts >

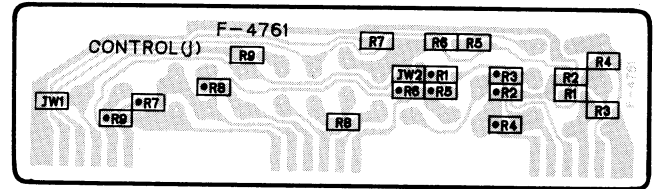

3-3. F-4845 AM/FM Band Selector Board

Component Side

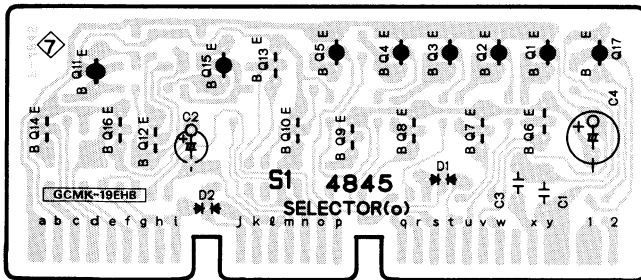

Pattern Side < Chip Parts >

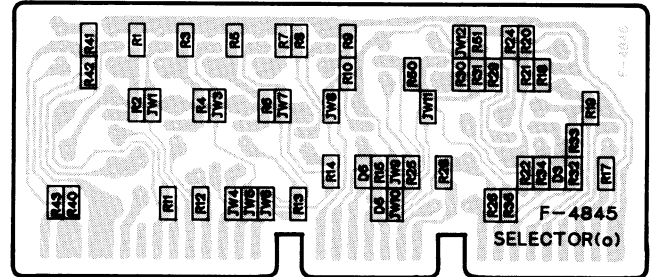

3-4. F-4853 FM IF Amp. Board

Component Side

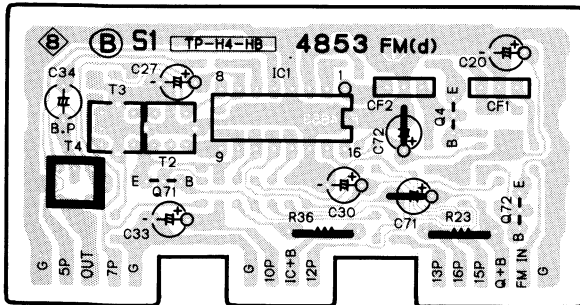

Pattern Side < Chip Parts >

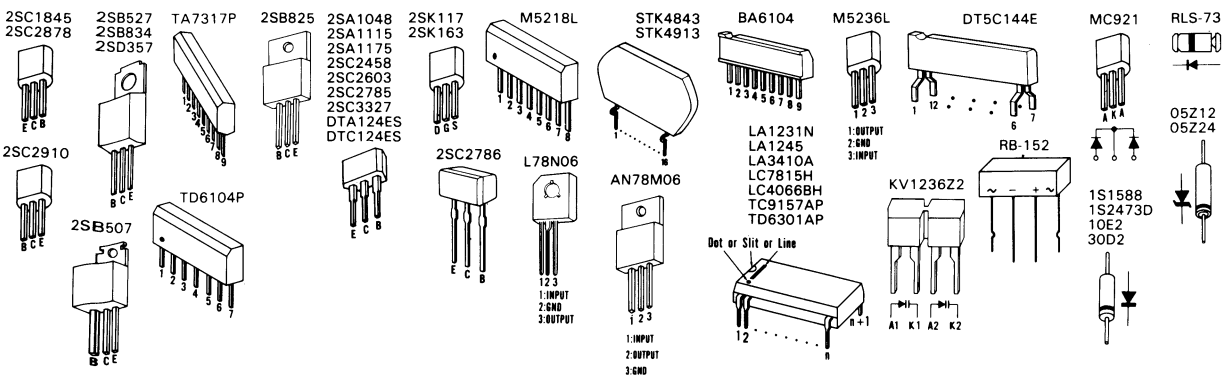
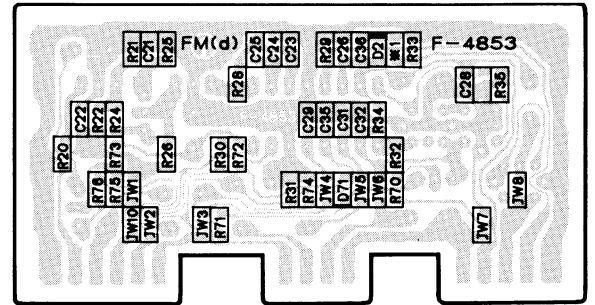

3-5. F-5409 Power Amp. & Power Supply Board

Component Side

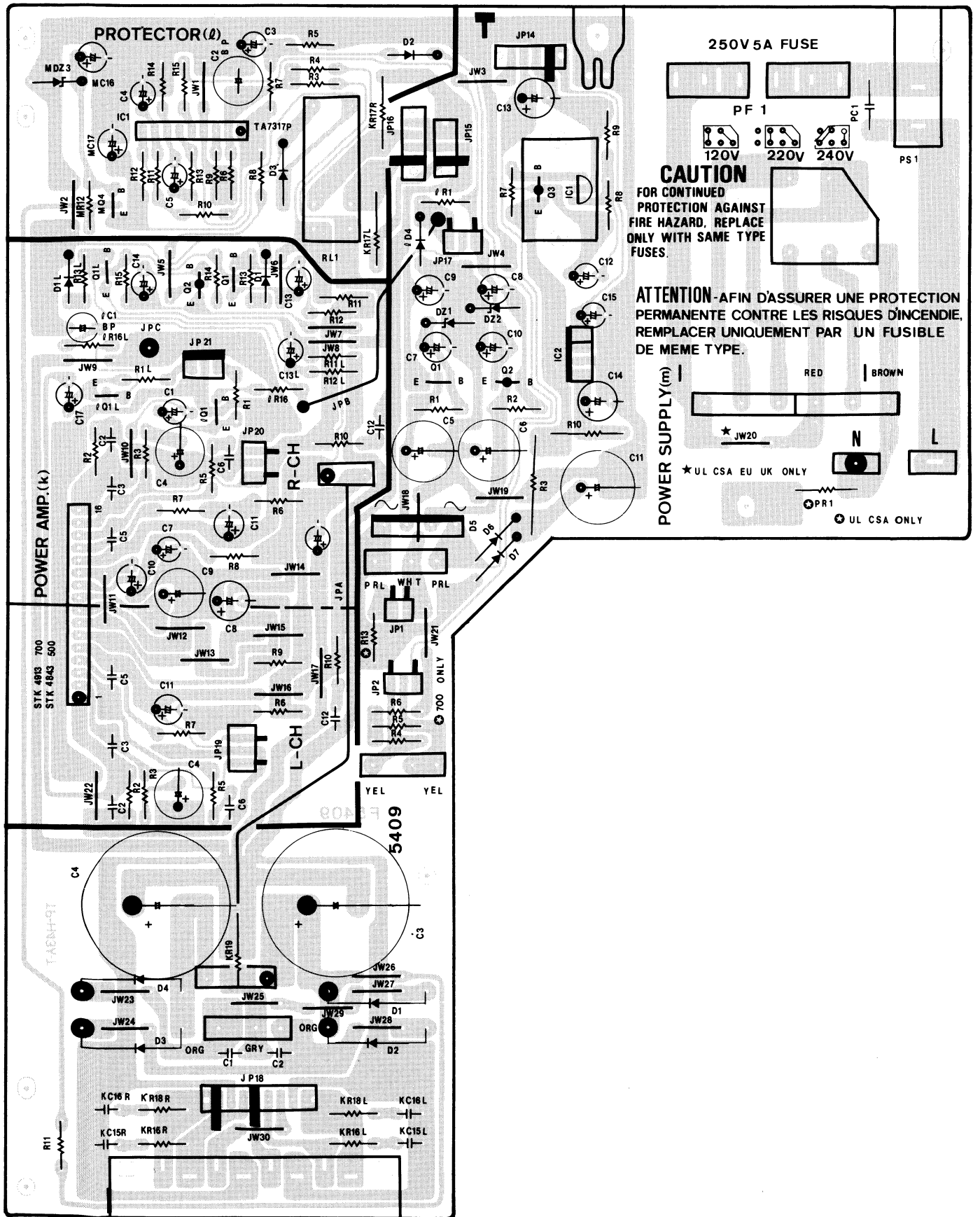

3-6. F-5410 Speaker Switch Board
Component Side

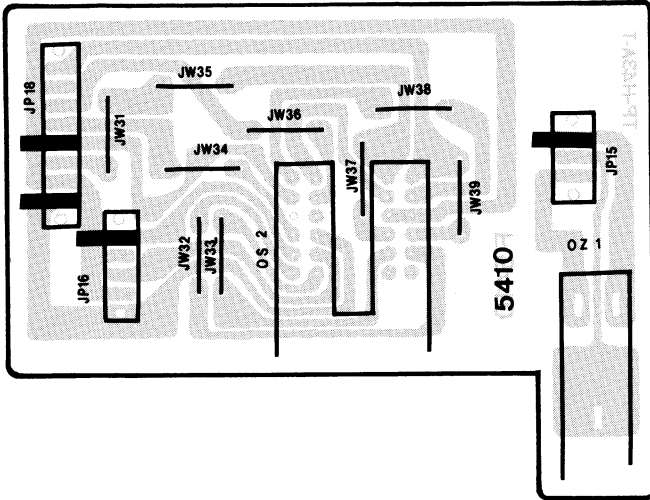

3-7. F-5414 Master Volume Board
Component Side

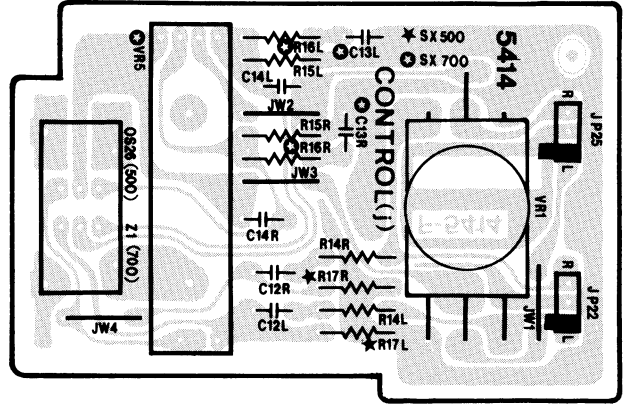

3-8. F-5412 Control Switch Board
Component Side

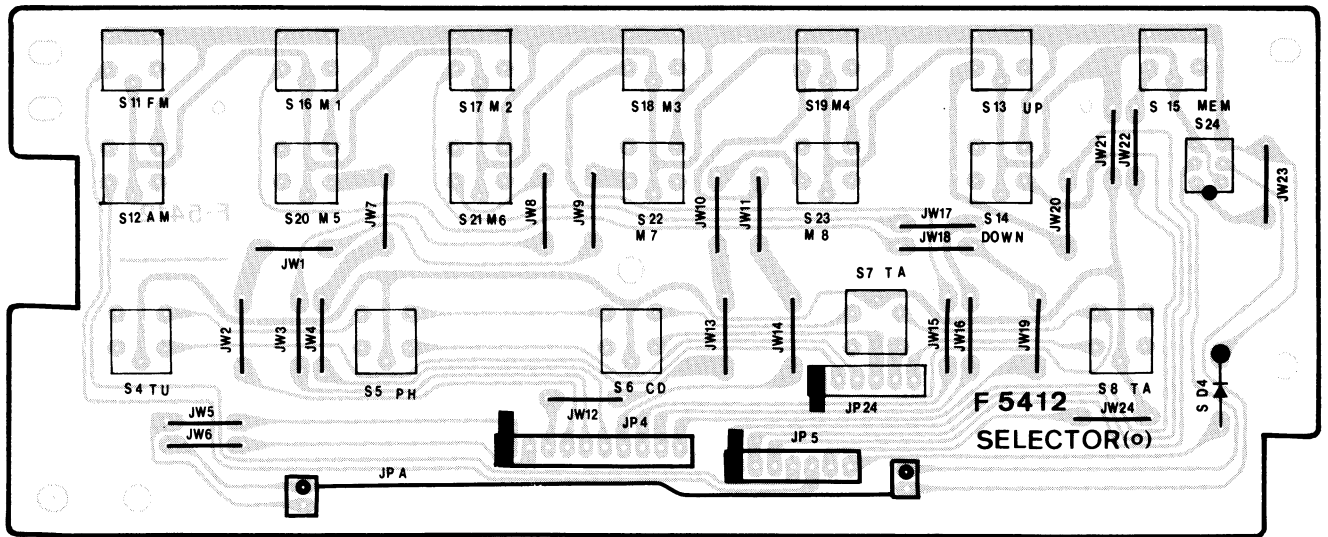

3-9. F-5413 Tone Control Board
Component Side

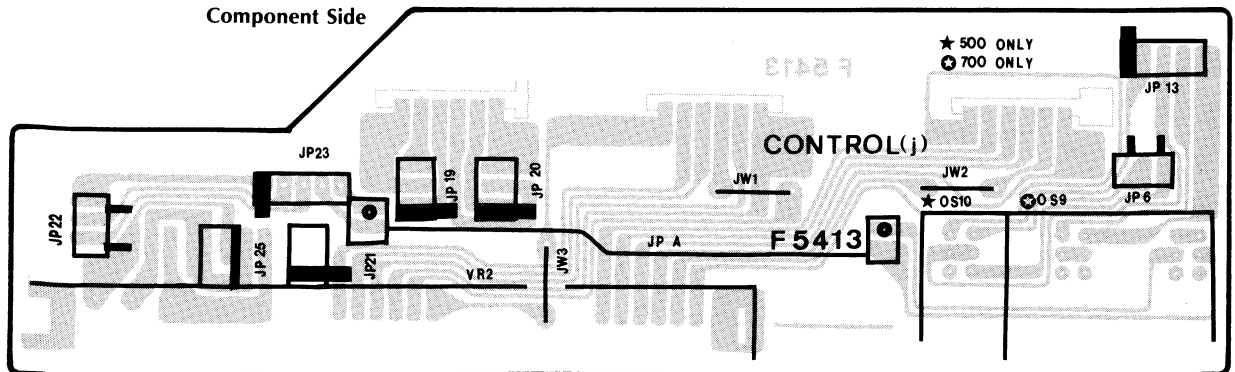

3-10. F-5411 Input Terminal & Selector IC Board
Component Side

- 2SC1845
- 2SC2878
- 2SC2910
- 2SB825
- 2SA1048
- 2SA1115
- 2SA1175
- 2SC2458
- 2SC2603
- 2SC2785
- 2SC3327
- DTA124ES
- DTC124ES
- 2SB527
- 2SB834
- 2SD357
- 2SB507
- 2SK117
- 2SK183
- 2SA1048
- 2SA1115
- 2SA1175
- 2SC2458
- 2SC2603
- 2SC2785
- 2SC3327
- DTA124ES
- DTC124ES
- 2SC1845
- 2SC2878
- 2SC2910
- 2SB825
- 2SA1048
- 2SA1115
- 2SA1175
- 2SC2458
- 2SC2603
- 2SC2785
- 2SC3327
- DTA124ES
- DTC124ES
- 2SC1845
- 2SC2878
- 2SC2910
- 2SB825
- 2SA1048
- 2SA1115
- 2SA1175
- 2SC2458
- 2SC2603
- 2SC2785
- 2SC3327
- DTA124ES
- DTC124ES
- 2SC1845
- 2SC2878
- 2SC2910
- 2SB825
- 2SA1048
- 2SA1115
- 2SA1175
- 2SC2458
- 2SC2603
- 2SC2785
- 2SC3327
- DTA124ES
- DTC124ES

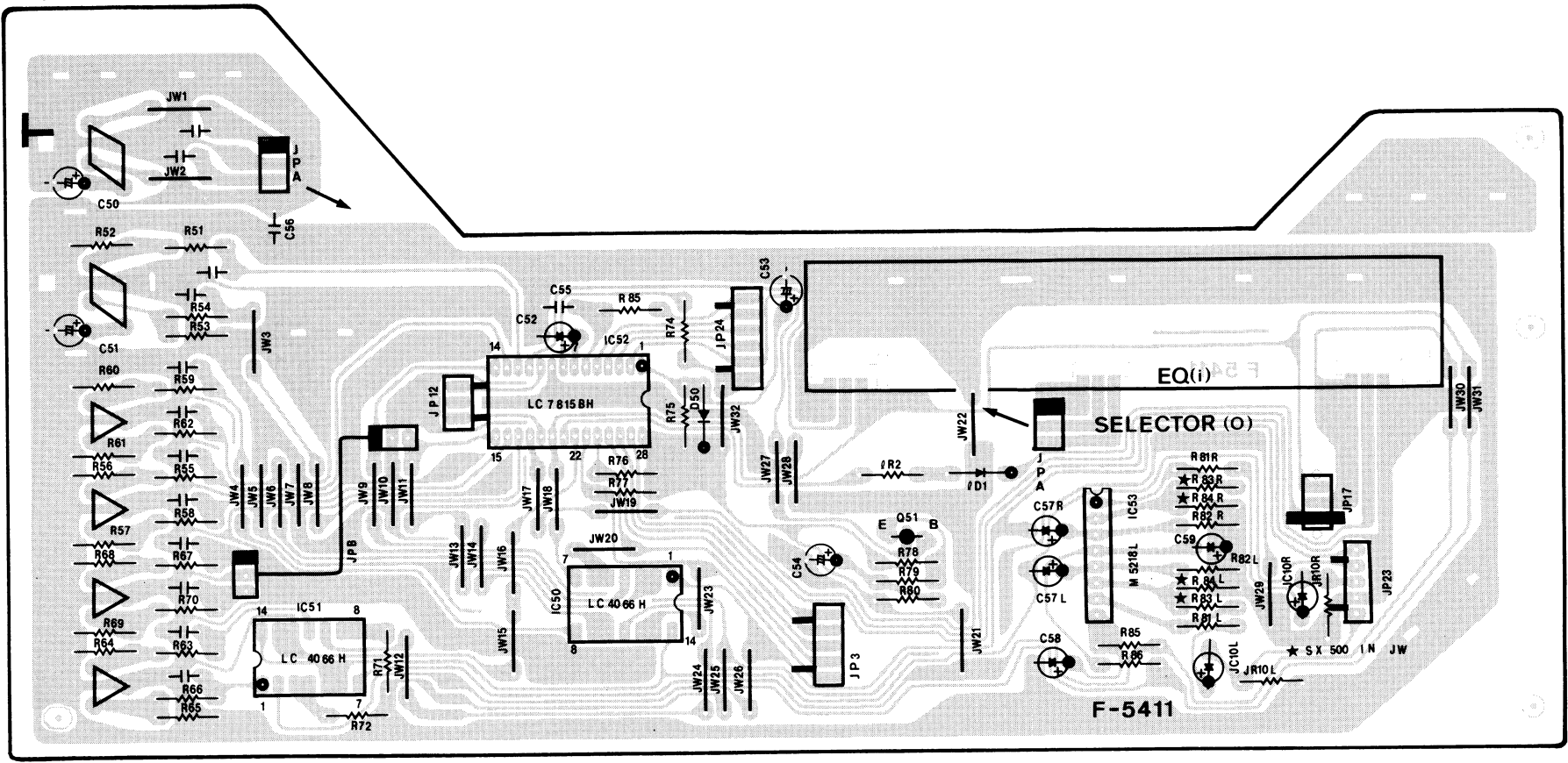

3-11. F-5416 Display Tube & PLL Control IC Board
Component Side

- STK4843
- STK4913
- BA6104
- LA1231N
- LA1245
- LA3410A
- LC7815H
- LC4066BH
- TC9157AP
- TD6301AP
- AN78M06
- DT5C144E
- M5236L
- RB-152
- KV123622
- MC921
- RLS-73
- 151588
- 152473D
- 10E2
- 30D2
- 05Z12
- 05Z24

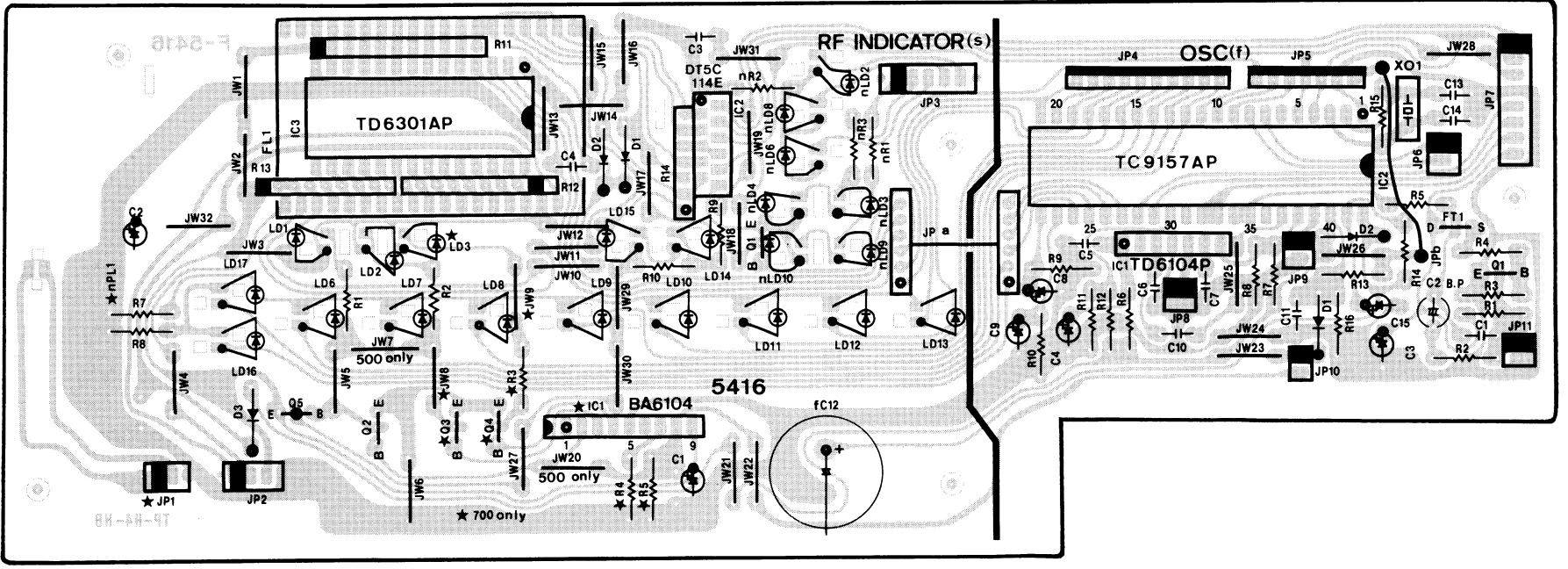

3-12. F-5415 Tuner Board
Component Side

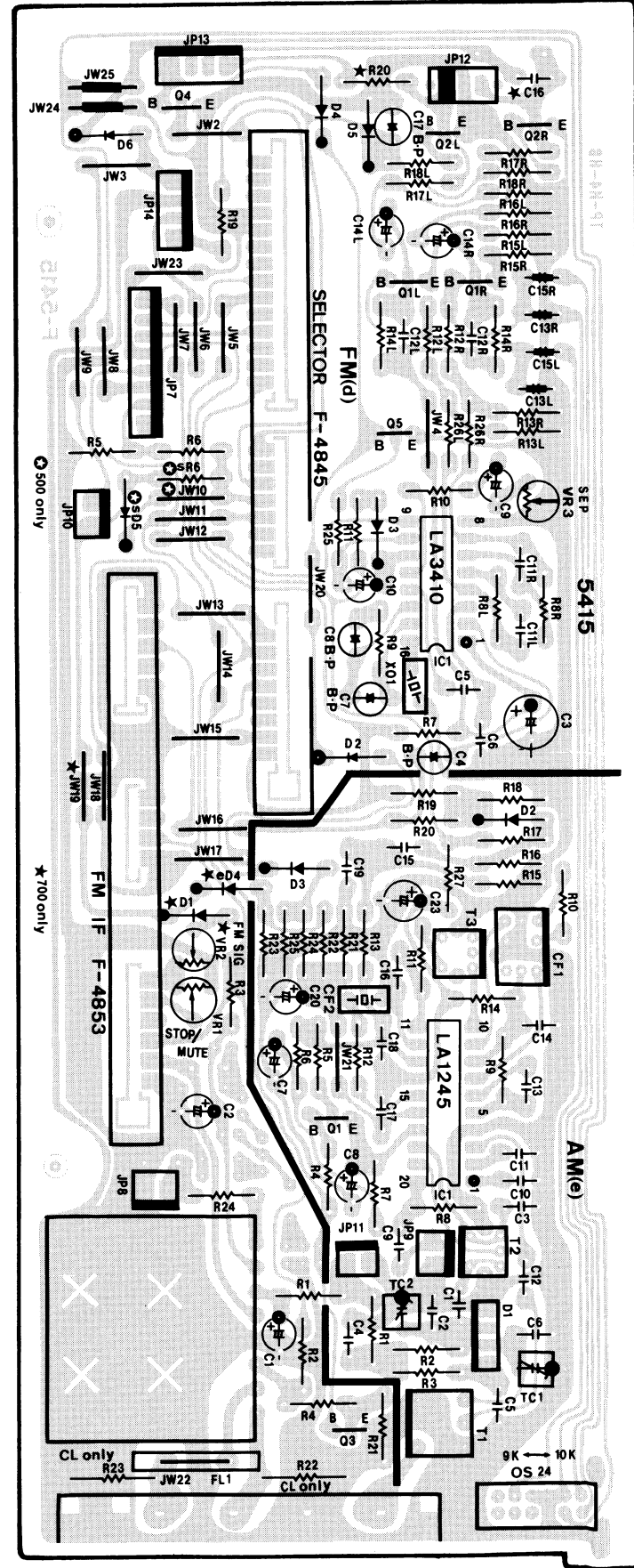

Parts List < F-5409 >

Parts No.	Stock No.	Description
mDZ2	46113800 or 46113900	05Z12-X 05Z12-Y
mDZ3	46115900 or 46116000	05Z24-X 05Z24-Y
△mR3	46908200	22Ω 3W N.I.R.
△mR10	46249500	150Ω 1W N.I.R.
△mR11	46229600	330Ω 1/2W N.I.R. (S-X700)
△	46229200	150Ω 1/2W N.I.R. (S-X500)
△mR13	48581900	56Ω 5W W.R. (S-X700)
mC3	08300300	6800μF 56V E.C. (S-X700)
	46363300	3900μF 42V E.C. (S-X500)
mC4	08300300	6800μF 56V E.C. (S-X700)
	46363300	3900μF 42V E.C. (S-X500)
△pC1	46425800	0.01μF 400V C.C.
△	or 46943200	0.01μF 400V C.C.
△pF1	48267300	Fuse 5A 250V (S-X700-120V)
△	48266900	Fuse 2.5A 250V (S-X700-220/240V)
△	48267000	Fuse 3A 250V (S-X500-120V)
△	48266700	Fuse 1.5A 250V (S-X500-220/240V)
△pS1	46360300	Push SW., Power
qZ12	46947500	8P Terminal, Speaker

4-6. F-5410 Speaker Switch Board

Parts No.	Stock No.	Description
oS2	48582900	Push SW., SPEAKERS
oS1	46579600	Jack, PHONES

4-7. F-5411 Input Terminal & Selector IC Board
(Stock No. 00987301 = S-X700/Stock No. 00990001 = S-X500)

Parts No.	Stock No.	Description
•Diode		
ID1	03117600 or 46086000	1S2473T77 1S1588TP-3
•Transistor		
oQ51	46367001 or 46367201	2SA1115 2SA1048
•IC		
oIC50	46255000	LC4066BH
oIC51	46255000	LC4066BH
oIC52	46394800	LC7815H
oIC53	46078900	M5218L
•Diode		
oD50	03117600 or 46086000	1S2473T77 1S1588TP-3
qZ13	48528400	2P Terminal, PHONO, CD
qZ14	48528200	4P Terminal, TAPE-1/VIDEO, TAPE-2

4-8. F-5412 Control Switch Board
(Stock No. 00987401 = S-X700/Stock No. 00990101 = S-X500)

Parts No.	Stock No.	Description
oS4	48306900	Push SW., TUNER
oS5	48306900	Push SW., PHONO
oS6	48306900	Push SW., CD
oS7	48306900	Push SW., TAPE-1/VIDEO
oS8	48306900	Push SW., TAPE-2
oS11	48306900	Push SW., FM
oS12	48306900	Push SW., AM
oS13	48306900	Push SW., UP•A
oS14	48306900	Push SW., DOWN•V
oS15	48306900	Push SW., MEMORY
oS16	48306900	Push SW., STATION 1•9
oS17	48306900	Push SW., STATION 2•10
oS18	48306900	Push SW., STATION 3•11
oS19	48306900	Push SW., STATION 4•12
oS20	48306900	Push SW., STATION 5•13
oS21	48306900	Push SW., STATION 6•14
oS22	48306900	Push SW., STATION 7•15
oS23	48306900	Push SW., STATION 8•16
oS24	46463300	Push SW., CHANNEL CALL
•Diode		
sD4	03117600 or 46086000	1S2473T77 1S1588TP-3

4-9. F-5413 Tone Control Board

Parts No.	Stock No.	Description
jVR2	48529900	50kΩ V.R., BALANCE•TREBLE• BASS
oS9	48529400	Push SW., MODE•HI-B•END• TUNING (S-X700)
oS10	46549600	Push SW., TUNING/MODE (S-X500)

4-10. F-5414 Master Volume Board

Parts No.	Stock No.	Description
jVR1	48529700	150KBX2 V.R., VOLUME
jVR5	48529600	150kΩ (C)X2 V.R., LOUDNESS (S-X700)
oS26	48562300	Push SW., LOUDNESS (S-X500)

4-11. F-5415 Tuner Board (Stock No. 00987701 = S-X700/Stock No. 00990401 = S-X500)

Parts No.	Stock No.	Description	Parts No.	Stock No.	Description
dZ1	46562600	FM Frontend Pack	dVR1	46634300	10k Ω S.V.R., MUTE
•Transistor			dVR2	46634700	47k Ω S.V.R., Signal Level
dQ1	46367101	2SC2603	dVR3	46635100	220k Ω S.V.R., VCO
	or 46367301	2SC2458	•Transistor		
	or 46391901	2SC2785	eQ1	46367101	2SC2603
dQ2	46540801	2SC2878		or 46367301	2SC2458
	or 46604301	2SC3327		or 46391901	2SC2785
dQ3	46719900	DTC124ES	•IC		
dQ4	46719900	DTC124ES	eIC1	07237200	LA1245
dQ5	46719900	DTC124ES	eD1	46146300	Variable Capacitance, Diode KV1236Z2
•IC			•Diode		
dIC1	48491000	LA3410A	eD2	03117600	1S2473T77
dXO1	48128400	Ceramic OSC Element KBR-457HS		or 46086000	1S1588TP-3
•Diode			eD3	03117600	1S2473T77
dD1	03117600	1S2473T77		or 46086000	1S1588TP-3
	or 46086000	1S1588TP-3	eD4	03117600	1S2473T77 (S-X700)
dD2	03117600	1S2473T77		or 46086000	1S1588TP-3 (S-X700)
	or 46086000	1S1588TP-3	Δ eR27	46228200	22 Ω 1/2W N.I.R.
dD3	03117600	1S2473T77	eC16	46695200	0.01 μ F 50V F.C.
	or 46086000	1S1588TP-3	eTC1	46437400	Trimmer Capacitor 20pF
dD4	03117600	1S2473T77	eTC2	46437400	Trimmer Capacitor 20pF
	or 46086000	1S1588TP-3	eCF1	48069800	Ceramic Filter CFLZ450
dD5	03117600	1S2473T77	eCF2	46578100	Ceramic Filter BFU-450C10N
	or 46086000	1S1588TP-3	eT1	48528900	AM ANT Coil
dD6	03117600	1S2473T77	eT2	46394700	AM OSC Coil
	or 46086000	1S1588TP-3	eT3	46369600	AM IF Coil
Δ dR3	46227800	10 Ω 1/2W N.I.R.	oS24	48529800	Slide SW., de-emphasis
Δ dR7	46228200	22 Ω 1/2W N.I.R.	qZ15	46547300	4P Terminal, ANTENNA
dC4	48102000	10 μ F 16V E.B.	•Diode		
dC6	46692800	1000pF 50V F.C.	sD5	03117600	1S2473T77 (S-X500)
dC7	48103200	0.47 μ F 50V E.B.		or 46086000	1S1588TP-3 (S-X500)
dC8	48103400	1 μ F 50V E.B.			
dC12	46694400	4700pF 50V F.C.			
dC13	46696100	0.024 μ F 50V F.C.			
dC15	46695500	0.013 μ F 50V F.C.			
dC16	46697300	0.075 μ F 50V F.C. (S-X700)			
dC17	48103500	2.2 μ F 50V E.B.			

4-12. F-5416 Display Tube & PLL Control IC Board (Stock No. 00987801 = S-X700/Stock No. 00990501 = S-X500)

Parts No.	Stock No.	Description	Parts No.	Stock No.	Description
•Transistor			sQ3	46719900	DTC124ES (S-X700)
fQ1	46367101	2SC2603	sQ4	46719900	DTC124ES (S-X700)
	or 46367301	2SC2458	sQ5	46719800	DTA124ES
	or 46391901	2SC2785	•IC		
•FET			sIC1	48054400	BA6104 (S-X700)
fft1	46643501	2SK163-K2	sIC2	48054300	DT5C144E
	or 46643502	2SK163-L1	sIC3	46410100	TD6301AP
	or 46643601	2SK117-Y	•Diode		
	or 46643602	2SK117-GR	sD1	03117600	1S2473T77
•IC			or 46086000	1S1588TP-3	
fic1	07225000	TD6104P	sD2	03117600	1S2473T77
fic2	48128000	TC9157AP	or 46086000	1S1588TP-3	
			sD3	03117600	1S2473T77
fxO1	07237700	Quartz Crystal NR-18	or 46086000	1S1588TP-3	
•Diode			sFL1	48170300	FL. Display Tube, FG78N2
fd1	03117600	1S2473T77	•LED		
or 46086000	1S1588TP-3		sLD1	48076200	SEL2913K, SIGNAL 1
fd2	03117600	1S2473T77	sLD2	48076200	SEL2913K, SIGNAL 2
or 46086000	1S1588TP-3		sLD3	48076200	SEL2913K, SIGNAL3 (S-X700)
fc2	48103500	2.2 μ F 50V E.B.	sLD6	48272600	SEL2213C, CHANNEL DIS. 1/9
fc3	48153700	4.7 μ F 16V E.C.	sLD7	48272600	SEL2213C, CHANNEL DIS. 2/10
fc4	48154300	22 μ F 25V E.C.	sLD8	48272600	SEL2213C, CHANNEL DIS. 3/11
fc8	48155800	1 μ F 50V E.C.	sLD9	48272600	SEL2213C, CHANNEL DIS. 4/12
fc9	48155800	1 μ F 50V E.C.	sLD10	48272600	SEL2213C, CHANNEL DIS. 5/13
fc12	48388400	4700 μ F 6.3V E.C.	sLD11	48272600	SEL2213C, CHANNEL DIS. 6/14
fc15	48155200	0.1 μ F 50V E.C.	sLD12	48272600	SEL2213C, CHANNEL DIS. 7/15
•LED			sLD13	48272600	SEL2213C, CHANNEL DIS. 8/16
nLD2	48272600	SEL2213C, TUNER	sLD14	48272600	SEL2213C, FM STEREO
nLD3	48076200	SEL2913K, TAPE-1/VIDEO	sLD15	48272600	SEL2213C, FM STEREO
nLD4	48076200	SEL2913K, TAPE-1/VIDEO	sLD16	48076200	SEL2913K, CHANNEL DIS. 9~16
nLD6	48272600	SEL2213C, AUX/CD	sLD17	48076200	SEL2913K, CHANNEL DIS. 1~8
nLD8	48272600	SEL2213C, PHONO	sR11	46353000	10k Ω X10 1/8W A.R.
nLD9	48076200	SEL2913K, TAPE-2	sR12	46349300	10k Ω X8 1/8W A.R.
nLD10	48076200	SEL2913K, TAPE-2	sR13	46349300	10k Ω X8 1/8W A.R.
nPL1	48586200	12V 0.15A Pilot Lamp (S-X700)	sR14	46344700	1.8k Ω X6 1/8W A.R.
•Transistor			sC1	48156400	10 μ F 50V E.C. (S-X700)
sQ1	46719900	DTC124ES		48153500	22 μ F 16V E.C. (S-X500)
sQ2	46719900	DTC124ES	sC2	48152300	100 μ F 6.3V E.C.

5. OTHER PARTS

5-1. Front View

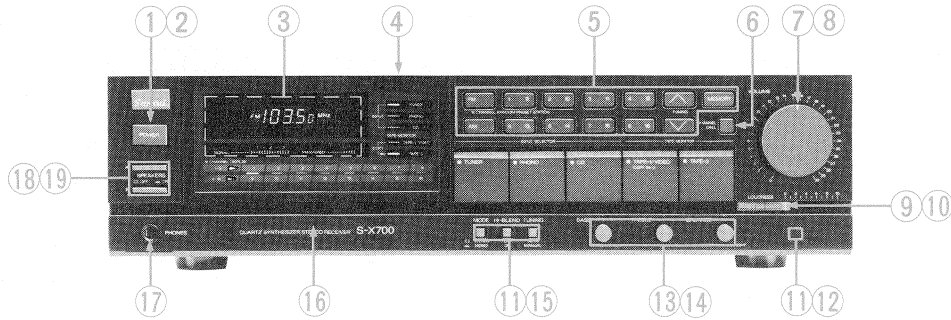

Parts List

Parts No.	Stock No.	Description
1	27244400	Knob, POWER
△ 2	46360300	Push SW., POWER
3	48170300	FL Display tube
4	27195000	Bonnet
5	48306900	Push SW., TUNER•PHONO•CD•TAPE-2•TAPE-1/VIDEO•FM•AM•UP•DOWN•MEMORY•1/9•2/10•3/11•4/12•5/13•6/14•7/15•8/16
6	46463300	Push SW., CHANNEL CALL
7	27205000	Knob, VOLUME
8	48529700	150kΩ V.R., VOLUME
9	27305500	Knob, LOUDNESS (S-X700 only)
10	48529600	150kΩ V.R., LOUDNESS (S-X700 only)
11	27205200	Knob, LOUDNESS (S-X500)•TUNING•MODE•HI-BLEND (X-700)

Parts No.	Stock No.	Description
12	48562300	Push SW., LOUDNESS (S-X500 only)
13	27206200	Knob, BASS•TREBLE•BALANCE
14	48529900	50kΩx2 + 250kΩ V.R., BASS•TREBLE•BALANCE
15	48529400	Push SW., MODE•HI-BLEND•TUNING (S-X700 only)
	46549600	Push SW., TUNING/MODE (S-X500 only)
16	27201300	Front Panel Ass'y (S-X700)
	27201400	Front Panel Ass'y (S-X500)
17	46579600	Jack, PHONES
18	27296200	Knob, SPEAKERS
19	48582900	Push SW., SPEAKERS

5-2. Top View

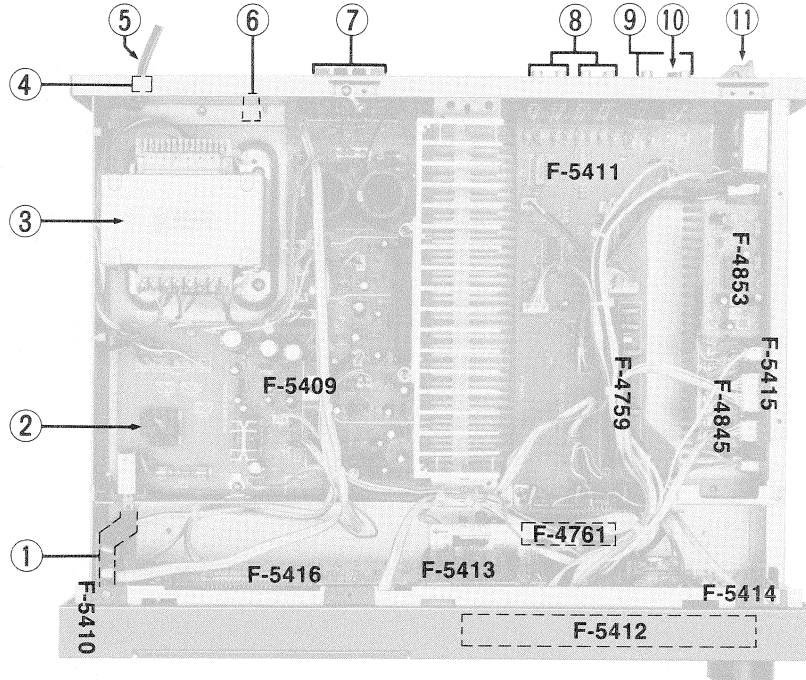

Parts List

Parts No.	Stock No.	Description
1	27205700	Joint shaft, power SW.
△ 2	46605200	Socket, voltage selector
△ 3	15026501	Power Transformer (S-X700-XX)
△	15026502	Power Transformer (S-X700-UL•CSA)
△	15026505	Power Transformer (S-X700-EU•UK•SEV)
△	15026601	Power Transformer (S-X500-XX)
△	15026602	Power Transformer (S-X500-UL•CSA)
△	15026605	Power Transformer (S-X500-EU•UK•SEV)
4	39106000	Strain Relief (XX)
	39104900	Strain Relief (UL•CSA•EU•UK•SEV)

Parts No.	Stock No.	Description
△ 5	38005700	Power Supply Cord (XX)
△	48188000	Power Supply Cord (UL•CSA)
△	38004500	Power Supply Cord (EU•SEV)
△	38004300	Power Supply Cord (UK)
△ 6	07204700	Slide SW., Voltage Selector (EU•UK•SEV)
7	46947500	8P Terminal, SPEAKERS
8	48528200	4P Terminal, TAPE-1/VIDEO•TAPE-2
9	48528400	2P Terminal, PHONO•CD
10	22301510	Ground Terminal
11	46547300	4P Terminal, ANTENNA

6. OVERALL WIRING DIAGRAM

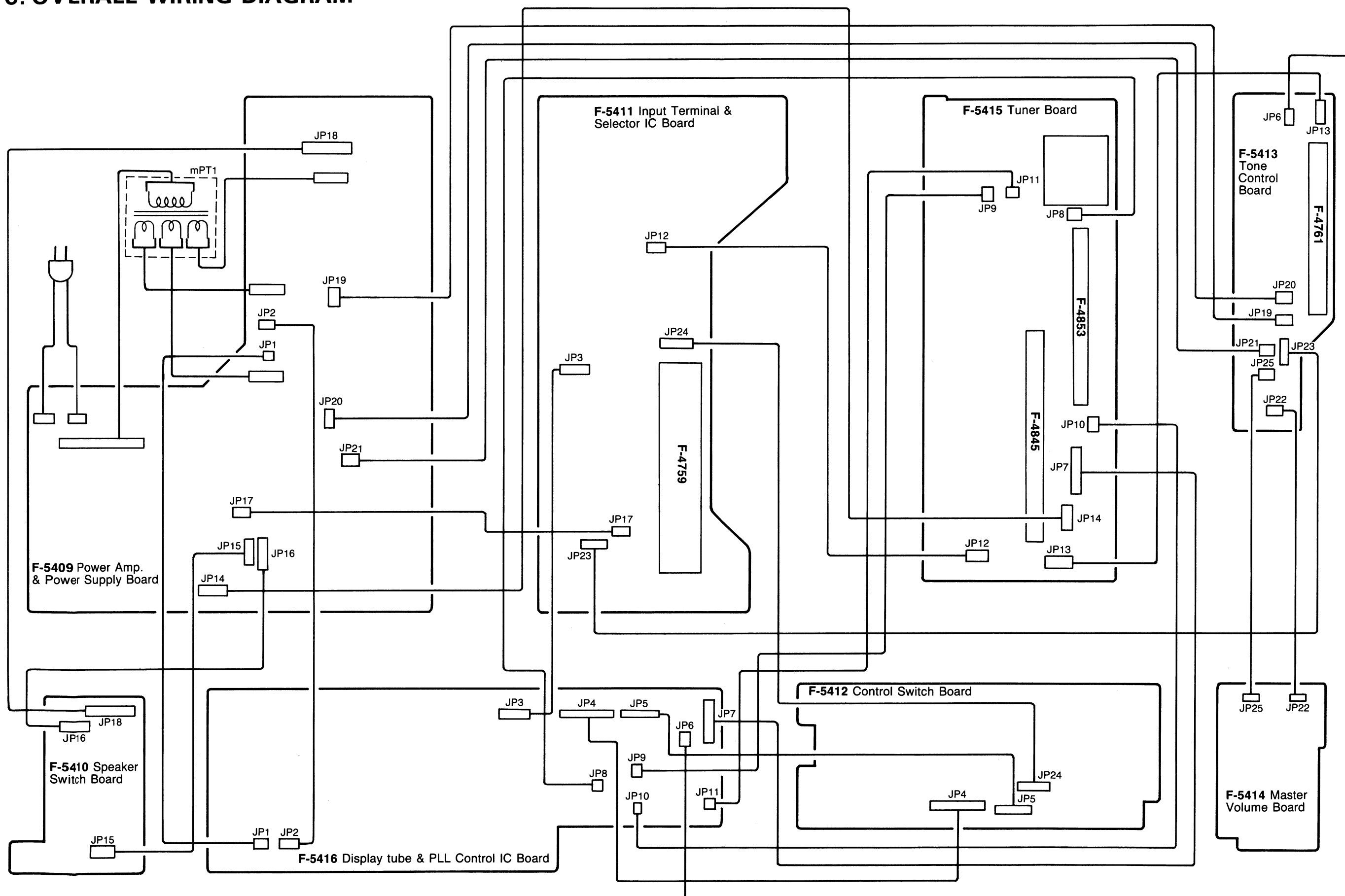

A B C D E F G H

7. SCHEMATIC DIAGRAM & INTERIOR BLOCK OF ICs 7-1. Tuner Section

• Design and specifications subject to change without notice for improvement.
 • La présentation et les spécifications sont susceptibles d'être modifiées sans préavis par suites d'améliorations éventuelles.
 • Änderungen, die dem technischen Fortschritt dienen, bleiben vorbehalten.

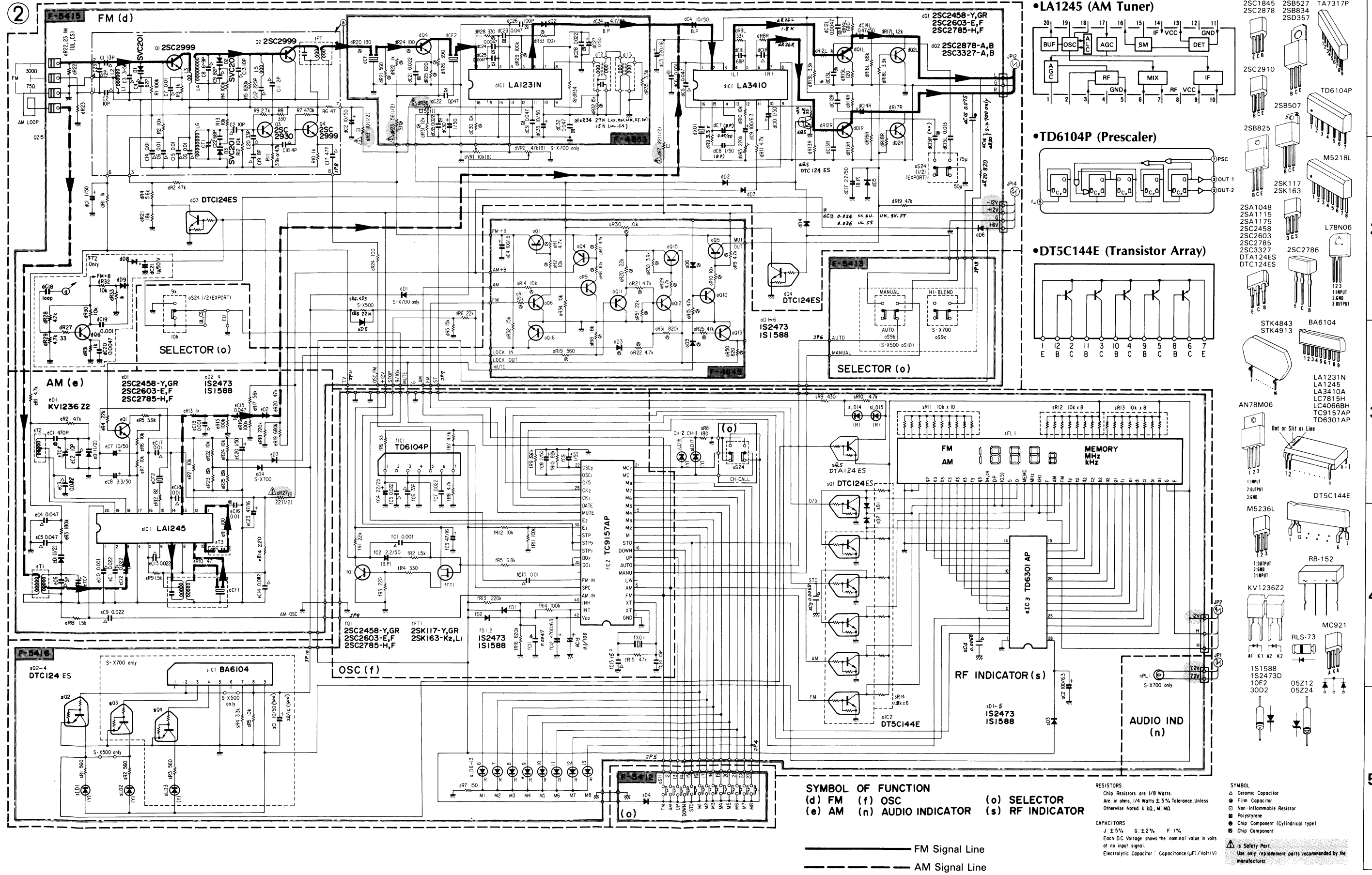

•TD6301P (7-Segment Decoder)

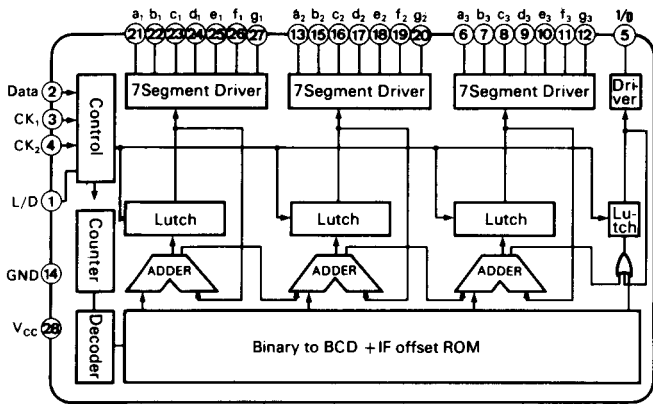

•BA6104 (LED Drive)

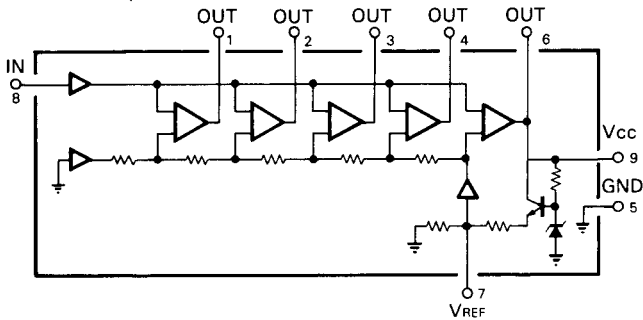

•LA3410 (MPX)

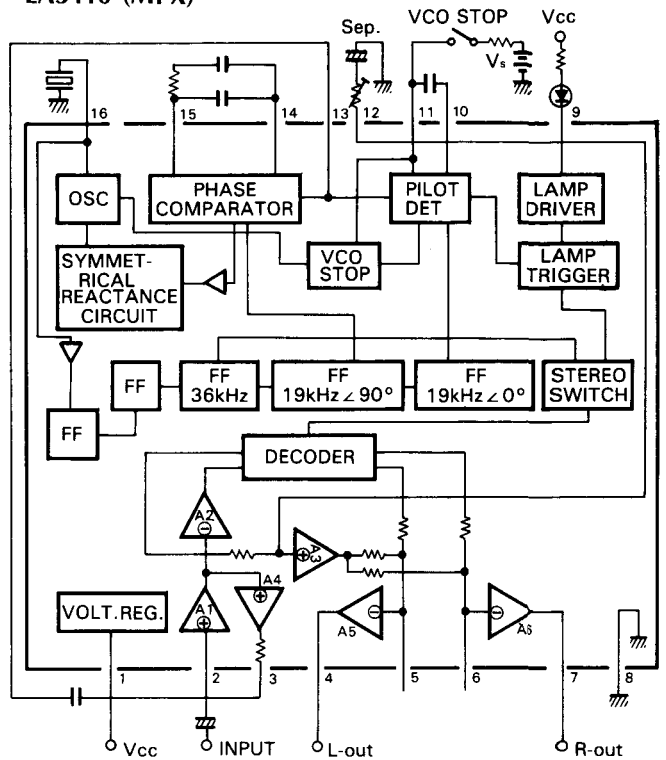

•TC9157AP (PLL & Control)

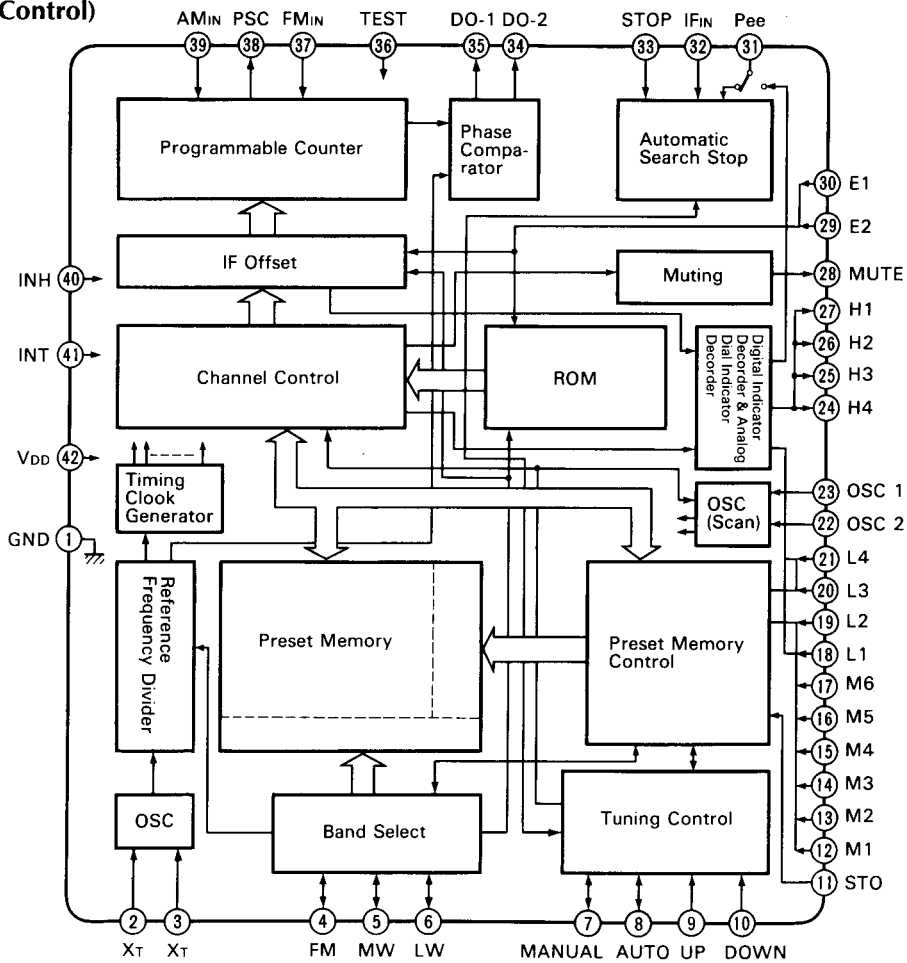

•Terminal Function of LSI-TC9157AP

Pin No.	Pin Name	Functions
2,3	X _T X _T	Terminals to connect a quartz oscillator for generating a reference frequency.
4 5 6	FM MW LW	Terminals to input a signal for switching FM/MW/LW band.
7 8	MANU- AL AUTO	Terminal to input a signal for switching the manual operation to automatic search operation or vice versa in the UP/DOWN tuning mode. "H": Automatic, "L": Manual
9 10	UP DOWN	Terminals to input a signal from the tuning key. *In manual operation: When the key is kept depressed for 0.3 sec or more in one-step/one-push step feeding, the operation changes to fast forwarding; when the key is released, the operation stops at the next stop. In this case, even if there is a station on the way, the station is neglected. *In automatic search operation: When the key is depressed once, the automatic search operation starts and stops automatically after having selected the desired station.
11	STO	Terminal to input a signal for storing data in the preset memory unit. Input/output terminal in which a LED driver is provided. *When depressing the STO key, the STO lamp comes on. Next, when any desired memory No. key is depressed, the data on receiving frequency is written into the memory unit and the STO lamp goes off. *When the STO key is depressed and the memory No. key is not depressed, the frequency data is released automatically.
12 17	M1 M6	Terminals to input a signal for designating memory address. Input/output terminals in which a LED driver is provided. *Terminals M1 to M6 designate the addresses of FM memory unit in FM receiving and the addresses of AM memory unit in AM receiving. *When depressing the STO key and any desired station key of M1 to M6, the data is written into the memory unit. *When depressing any desired station key of M1 to M6, the data is read out.
22	OSC 2	Terminal to connect a condenser and resistor for the oscillator for determining the speed of AM automatic search operation.
23	OSC 1	Terminal to connect a condenser and resistor for the oscillator for determining the speed of FM automatic search operation.
24 25 26 27	O/5 CK2 CK1 DATA	Terminals to output the data for displaying the received frequency digitally and a timing signal. The data fed to the driver TD6301P for displaying a static frequency and the timing signal are outputted once only when the frequency is updated in such case as when the power supply is tuned on, the UP/DOWN key is depressed, the automatic scanning operation is made, the data are read out of the memory unit, or FM/AM is switched. In the ordinary receiving state, this terminal is fixed to a "L" level. *O/5: For displaying 50 kHz during FM receiving in Europe. *Data: Binary coded frequency data and receiving band. *CK-1, CK-2: Initialize and transfer clock signals.
28	MUTE	Terminal to output the muting signal. The terminal is kept in "L" level in ordinary state, and in "H" level in muting.

Pin No.	Pin Name	Functions															
29 30	E2 E1	Terminals to input a signal for selecting destinations of Japan, USA, and Europe. *Inputs of terminals E1 and E2 are read and latched in INH=L state and in FM/AM switching. <table border="1" style="margin-left: 20px;"> <thead> <tr> <th>E1</th> <th>E2</th> <th>Mode</th> </tr> </thead> <tbody> <tr> <td>0</td> <td>0</td> <td>Japan</td> </tr> <tr> <td>1</td> <td>0</td> <td>Europe</td> </tr> <tr> <td>0</td> <td>1</td> <td>USA (MW 9kHz)</td> </tr> <tr> <td>1</td> <td>1</td> <td>USA (MW 10kHz)</td> </tr> </tbody> </table>	E1	E2	Mode	0	0	Japan	1	0	Europe	0	1	USA (MW 9kHz)	1	1	USA (MW 10kHz)
E1	E2	Mode															
0	0	Japan															
1	0	Europe															
0	1	USA (MW 9kHz)															
1	1	USA (MW 10kHz)															
31	STOP 3	When a IF450 kHz signal is applied to this terminal during automatic search operation, the scanning operation stops.															
32	STOP 2	Terminal to input a signal for performing the automatic search stop. When a "H" level signal is applied to STOP 1 and this terminal during automatic search operation, the scanning operation stops.															
33	STOP 1	Terminal to input a signal for slowing the speed of scanning operation. When a "H" level signal is applied to this terminal during automatic search operation, the speed of scanning operation halves.															
34 35	Do-2 Do-1	Terminals to output a signal from a phase comparator. These terminals can be used for FM and AM, separately, since the same signal is outputted from the terminals Do-1 and Do-2 at the same time.															
36	TEST	Terminal to input a signal of test mode. Test mode in "H" level.															
37	FM _{IN}	Terminal to input a signal from the FM programmable counter. An amplifier is provided in the input.															
38	PSC	Terminal to output a signal for controlling the Prescaler IC of TD6104P.															
39	AM _{IN}	Terminal to input a signal from the AM programmable counter. An amplifier is provided in the input.															
40	INH	Terminal to input a signal of inhibit. Ordinary operation in "H" level; inhibit operation in "L" level.															
41	INT	Terminal to input an initialize signal. This terminal changes to H level in the ordinary operation and to L level in the initialize operation.															
42 1	VDD VND	Power supply terminals. 5V ± 0.5V.															

•LA1231N (IF & Quadrature Detector)

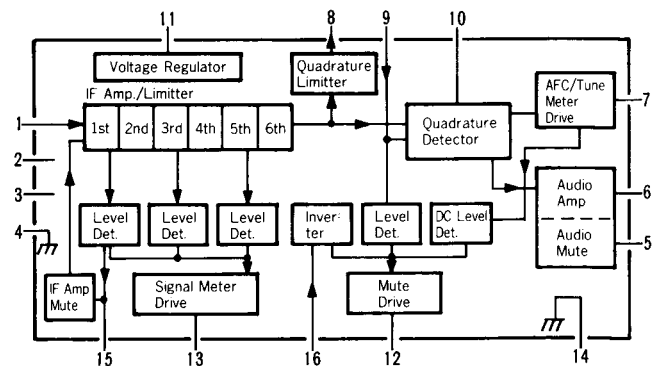

7-2. Amplifier Section

• Design and specifications subject to change without notice for improvement.
 • La présentation et les spécifications sont susceptibles d'être modifiées sans préavis par suites d'améliorations éventuelles.
 • Änderungen, die dem technischen Fortschritt dienen, bleiben vorbehalten.

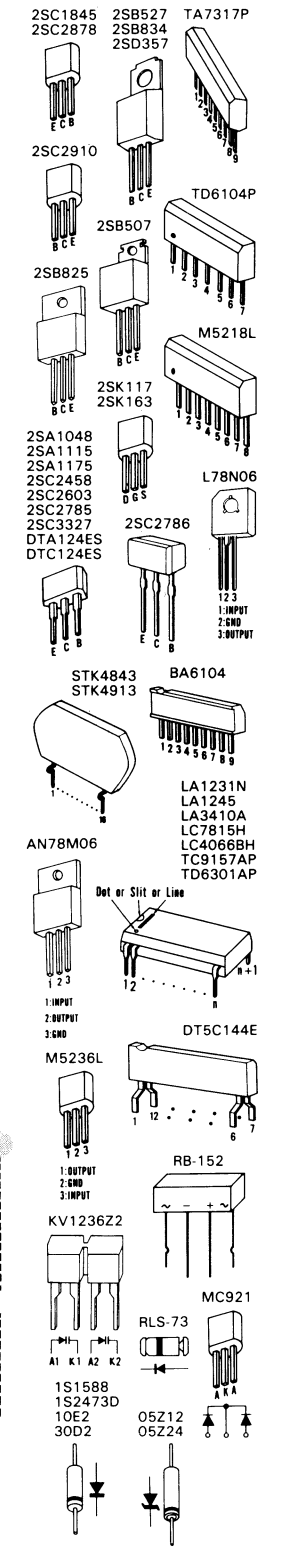
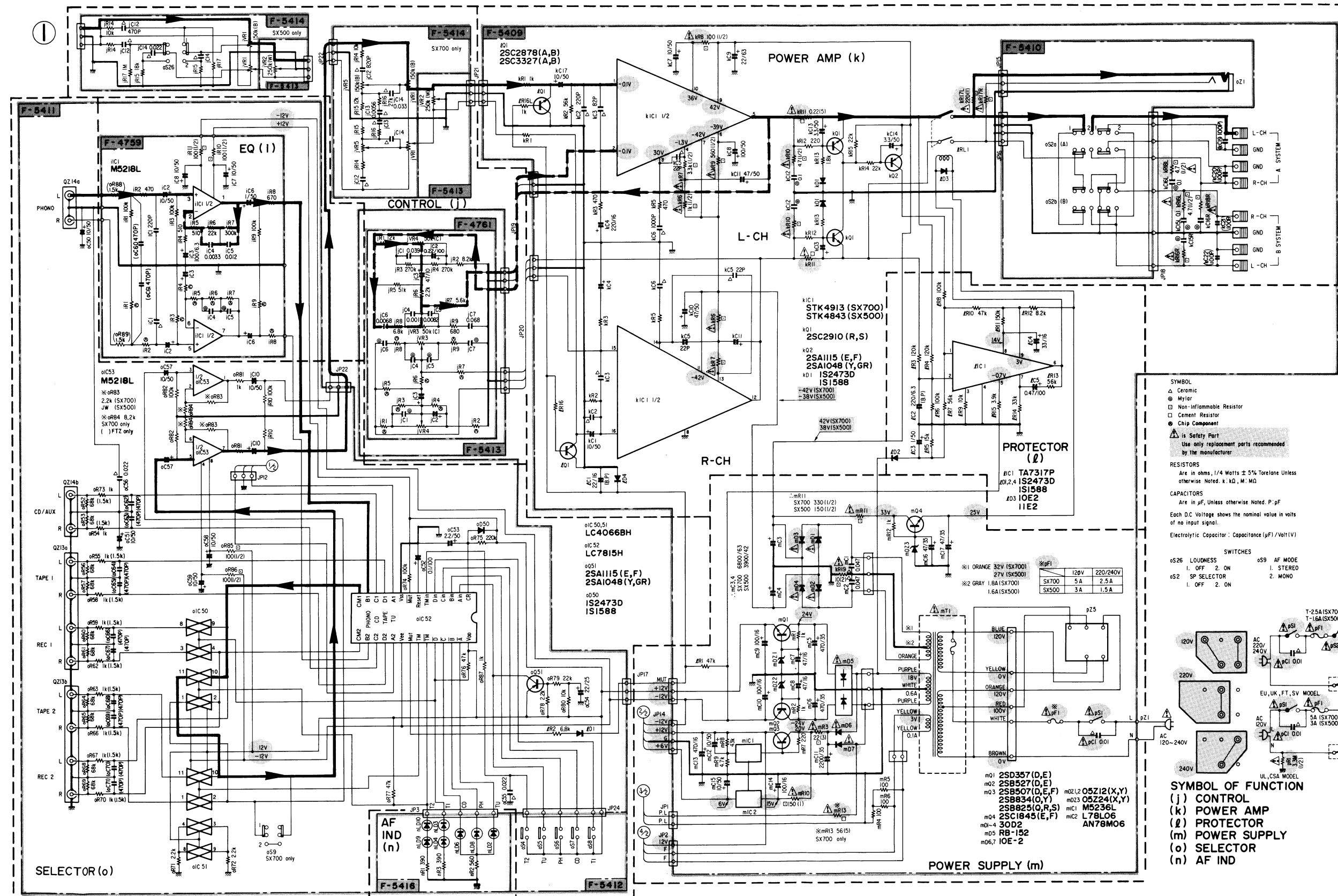

— Signal Line
 - - - N.F.B. Line

1
 2
 3
 4
 5

•LC7815H/LC7816 (Analog Function SW.)

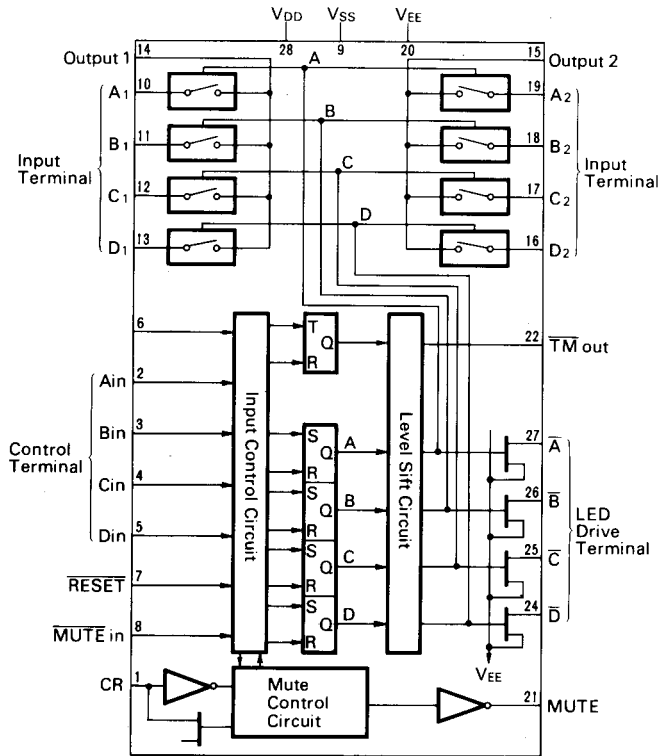

Condition of control input terminals Port (Pin No.)				Connected input terminal to output 1 and 2 terminals		Connected terminal to LED indicator
Ain (2)	Bin (3)	Cin (4)	Din (5)	PORT (Pin No.)	PORT (Pin No.)	PORT (Pin No.)
H	*	*	*	A1 (10)	A2 (19)	A (27)
L	H	*	*	B1 (11)	B2 (18)	B (28)
L	L	H	*	C1 (12)	C2 (17)	C (25)
L	L	L	H	D1 (13)	D2 (16)	D (24)

H: H level L: L level *: Don't care

•TA7317P (Protector)

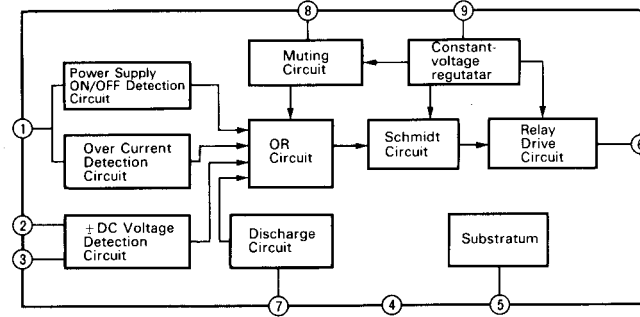

•M5236L (Regulator)

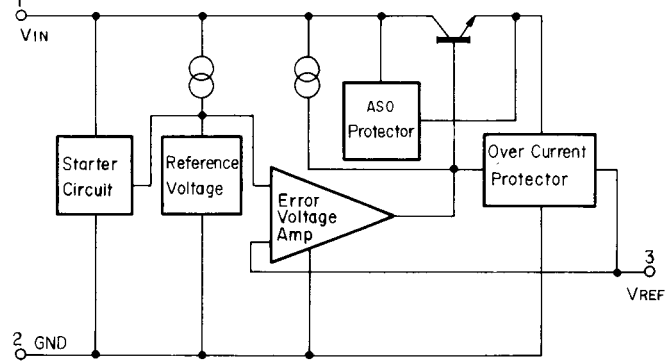

•STK4913 (Power Amp.)
•STK4843

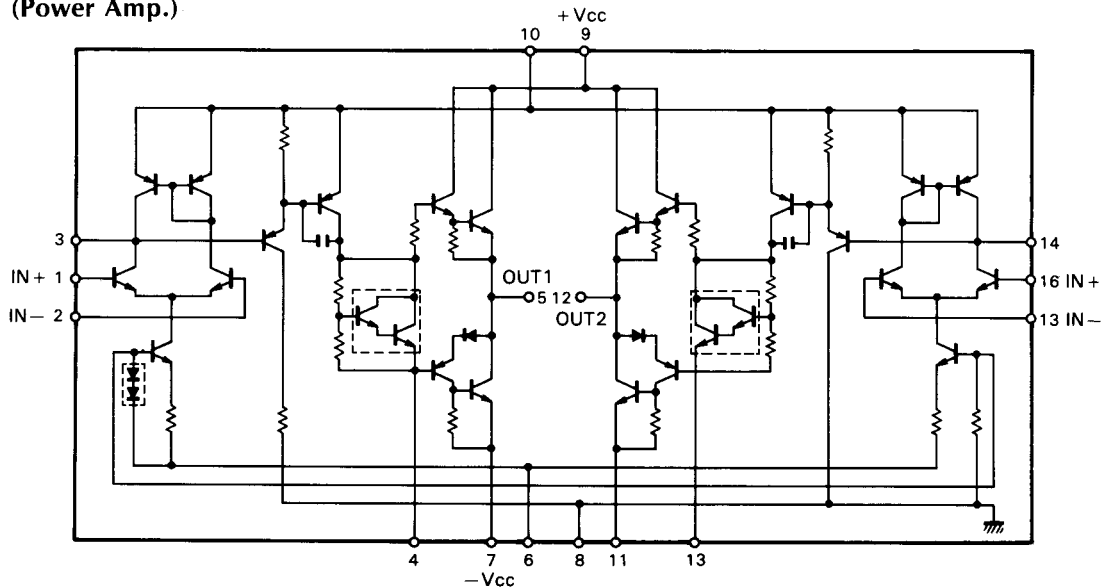

8. PACKING LIST

Parts No.	Stock No.	Description
1	47859600	Vinly Bag
2	27206800	Styrofoam Packing (Right)
3	27283500	Styrofoam Packing (Left)
4	27206600	Carton Case (S-X700)
	27206700	Carton Case (S-X500)

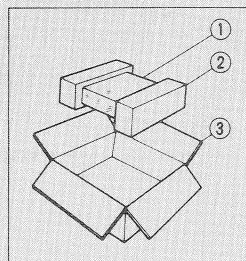

9. ACCESSORY LIST

Stock No.	Description
46051700	FM Antenna
46186100	AM Loop Antenna
07563000	Antenna Holder
48489800	Matching Transformer (EU,UK,SEV)
49013000	S-X700/X500 Operating Instruction (*E•F•S)
49013100	S-X700/X500 Operating Instruction (*G•I•Sw)

*** Note:**

E•F•S: English•French and Spanish Version
G•I•Sw: German•Italian and Swedish Version



SANSUI ELECTRIC CO., LTD.:

SANSUI ELECTRONICS CORPORATION:

SANSUI ELECTRONICS (U.K.) LTD.:
 SANSUI ELECTRONICS G.M.B.H.:

14-1, Izumi 2-chome, Suginami-ku, Tokyo 168 Japan
 PHONE: (03) 324-8891/TELEX: 232-2076 (International Division)
 1250 Valley Brook Ave. Lyndhurst, N.J. 07071 U.S.A.
 17150 South Margay Ave. Carson, California 90746 U.S.A.
 3036 Koapaka Street, Honolulu, Hawaii 96819 U.S.A.
 Unit 10A, Lyon Industrial Estate, Rockware Avenue, Greenford, Middx UB6, OAA, England
 Pau Ehrich Strasse 8, 6074 Rodermark 2, West Germany