

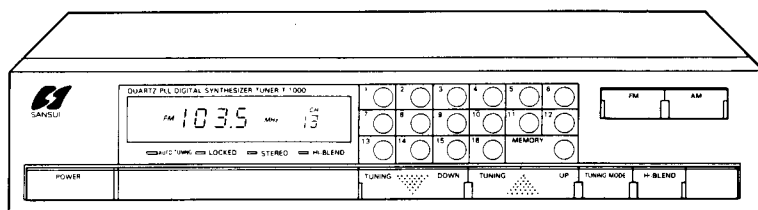

SERVICE MANUAL

T-1000 T-1000L

QUARTZ PLL DIGITAL
SYNTHESIZER TUNER



* This service manual applies to T-1000 and T-1000L with NEW SANSUI MARK on the front panel and also F-6000 main board in the unit.

CAUTION

1. Parts identified by the ⚠ symbol on the schematic diagram and the parts list are critical for safety.
Use only replacement parts that have critical characteristics recommended by the manufacturer.
2. Make leakage-current or resistance measurements to determine that exposed parts are acceptably insulated from the supply circuit before returning the appliance to the customer.

•SPECIFICATIONS

FM Section

Tuning range	88 to 108 MHz
Usable sensitivity	
Mono IHF	10.8 dBf (1.9 μ V : T100)
DIN	0.9 μ V
50 dB quieting sensitivity	
Mono	16.5 dBf
Stereo	37.0 dBf
Signal to noise ratio at 65 dBf	
Mono	75 dB
Stereo	70 dB
Distortion at 65 dBf	
Mono	less than 0.2% at 1,000 Hz
Stereo	less than 0.25% at 1,000 Hz
Alternate channel selectivity (at 400 kHz)	
Stereo	55 dB
Stereo separation	40 dB at 1,000 Hz
Frequency response	30 to 15,000 Hz +1.0 dB, -1.5 dB
Antenna input impedance	300 ohms balanced 75 ohms unbalanced

AM Section

Tuning range	530 to 1,600 kHz
Usable sensitivity	52 dB/m (398 μ V/m)
Signal to noise ratio	45 dB
Image response ratio	40 dB at 1,000 kHz

LW Section <T-1000L only>

Tuning range	153 to 281 kHz
Usable sensitivity	62 dB/m
Signal to noise ratio	45 dB
Image response ratio	35 dB at 220 kHz

Others

Power requirements	120/220/240V 50/60 Hz
For U.S.A. and Canada	120V (60 Hz)
Power consumption	10 Watts
Dimensions	430 mm (16-15/16")W 92 mm (3-5/8")H 227 mm (8-15/16")D
Weight	2.7 kg (6.0 lbs) net 3.5 kg (7.7 lbs) packed

- * Design and specifications subject to changes without notice for improvements.
- * Due to local laws and regulations, this unit sold in some areas are not equipped with variable voltage selectors.

NOTE

1. The symbols, EG, EI, EF and EU on the parts list and the schematic diagram mean followings respectively.
 EG Manufactured for F.R. Germany market.
 EI Manufactured for Italian market.
 EF Manufactured for French market.
 EU Manufactured for European (Except F.R. Germany, Italian and French) market.
 NON MARK Common Parts.
2. Some printed circuit boards are not supplied assembled. To separate these in this service manual, the stock numbers are not indicated for these boards. However, stock numbers for individual parts are indicated.
3. Since some capacitors and resistors are omitted from parts lists in this service manual, refer to the Common Parts List for capacitors and resistors, which was issued on June 1987.
4. Abbreviations in this service manual are as follows.

•Abbreviations List

C.R. : Carbon Resistor	E.B.L. : Low Leak Bi-Polar Electrolytic Capacitor
S.R. : Solid Resistor	Ta.C. : Tantalum Capacitor
Ce.R. : Cement Resistor	F.C. : Film Capacitor
M.R. : Metal Film Resistor	M.P. : Metalized Paper Capacitor
F.R. : Fusing Resistor	P.C. : Polystyrene Capacitor
N.I.R. : Non-Inflammable Resistor	M.M.C. : Metalized Mylar Capacitor
A.R. : Array Resistor	A.C. : Array Capacitor
C.C. : Ceramic Capacitor	V.R. : Variable Resistor
C.T. : Ceramic Capacitor, Temperature Compensation	S.V.R. : Semi Variable Resistor
E.C. : Electrolytic Capacitor	SW. : Switch
E.L. : Low Leak Electrolytic Capacitor	Chip R. : Chip Resistor
E.B. : Bi-Polar Electrolytic Capacitor	Chip C. : Chip Capacitor

1. PACKING LIST

Parts No.	Stock No.	Description
1	84519200	Vinyl Bag (T-1000)
	27306000	Vinyl Bag (T-1000L)
2	84519300	Styrofoam Packing (T-1000)
	27652900	Styrofoam Packing (T-1000L)
3	84566200	Carton Case (T-1000)
	27622100	Carton Case (T-1000L)

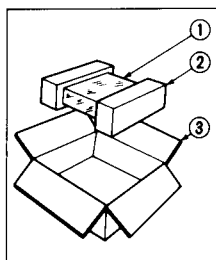

2. ACCESSORY LIST

Stock No.	Description
48835500	AM Loop Antenna
07563000	AM Antenna Holder
46051700	FM Antenna
46118600	PJP Cord
or 38103200	PJP Cord
or 48802200	PJP Cord
84453600	T-1000/T-1000L Operating Instruction (*E•F•S•I)
84453700	T-1000/T-1000L Operating Instruction (*G•Sw)

*Note:

E•F•S•I: English•French•Spanish and Italian Version
G•Sw: German and Swedish Version

3. BLOCK DIAGRAM

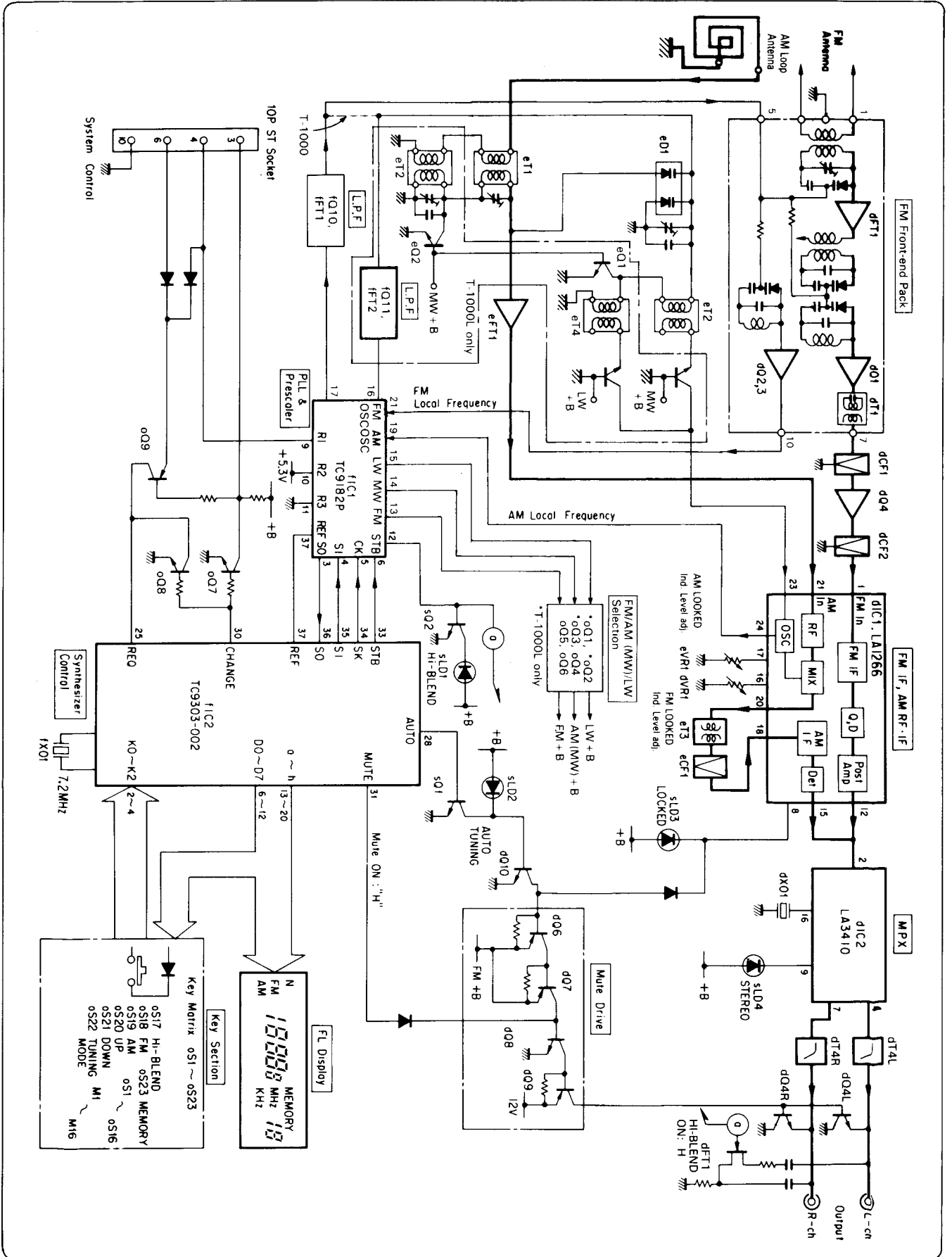

4. ADJUSTMENTS (See F-6000 Parts Location on page 8)

4-1. FM Adjustment

- Note:** 1. FM Switch ON
 2. Hi-BLEND Switch OFF
 3. Connect as shown Fig. 4-1.

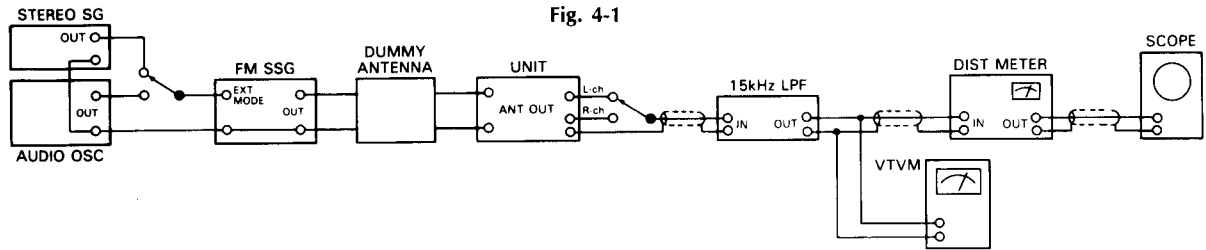

STEP	SUBJECT	FEED SIGNAL		MEASURE OUTPUT	ADJUST	ADJUST FOR	REMARKS
		FROM	TO				
1.	IF Coil Adj.	98MHz ANT Input 20dBf (14.8dB), 1kHz (100% MOD.), FM SSG	FM ANT Terminal	Between Point (A) (Pin 16 of dIC1) & GND (F-6000), DC Volt Meter	IFT Coil (Front-end Pack)	Max. DC Volt	
2.	Discriminator Coil Adj.	1) 98MHz ANT Input 65dBf (59.8dB), No MOD., FM SSG	FM ANT Terminal	Between Point (B) & (C) (Across the dR23) (F-6000) DC Volt Meter	dT1 (F-6000)	DC 0V ± 30mV	•Repeat procedures as stated in subject 1) & 2).
		2) 98MHz ANT Input 65dBf (59.8dB), 1kHz (100% MOD.), FM SSG	Same as above	Output L or R-ch, Dist Meter & SCOPE	dT2 (F-6000)	Min THD	
3.	LOCKED Indicator Level Adj.	98MHz ANT Input 23dBf (17.8dB), 1kHz (100% MOD.), FM SSG	FM ANT Terminal	LOCKED Indicator	dVR1 (F-6000)	LOCKED Indicator turns ON.	

◆ Technical Hint for FM Adjustment

There are two kind in indication of FM SSG output attenuator.
 1. Attenuator with marking of 75Ω open open indication type.
 2. Attenuator with marking of 75Ω load or close load or close indication type.
 FM SSG output level in this FM adjustment are described as open indication type.
 To feed FM signal, a dummy antenna circuit as Fig. 4-2 must be connected between FM SSG output and ANT terminal (300Ω) of the unit.

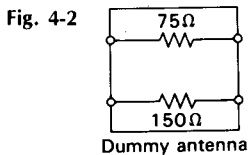

- The following table shows relations among FM SG attenuator indication (dB), available power ratio (dBf) and antenna terminal voltage (dB/μV) in each indication type.

	FM SG Attenuator Indication	Available Power Ratio	Antenna Terminal Voltage
Open indication type	0 dB 66 dB	-0.8 dBf 65.2 dBf	-6 dB/μV 60 dB/μV
Load or close indication type	0 dB 60 dB	5.2 dBf 65.2 dBf	0 dB/μV 60 dB/μV

4-2. AM Adjustment

- Note: 1. T-1000: AM Switch ON, T-1000L: MW/LW Switch MW
 2. Connect AM loop antenna to AM antenna terminal.
 3. Connect as shown Fig. 4-3.

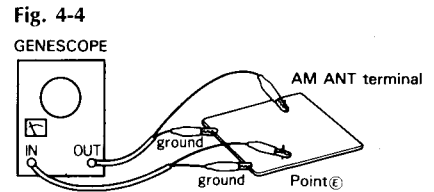
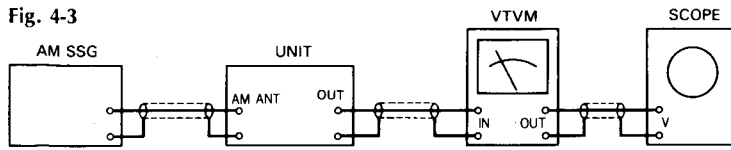

1) AM IF Adjustment & MW (AM) Tuning Adjustment

STEP	SUBJECT	FEED SIGNAL		MEASURE OUTPUT	ADJUST	ADJUST FOR	REMARKS
		FROM	TO				
1.	IF Coil Adj.	Genescope Output 60dB	AM ANT terminal	Between Point ⓔ (Pin 17 of d1C1) & GND (F-6000)	eT5 (eCF1) (F-6000)	MAX, Waveform	
2.	531kHz (or 530kHz) Tuning Adj.	No Input	—	FL Display	TUNING UP, DOWN Button	531kHz (or 530kHz)	•Repeat procedures as stated in STEP 1 and 2
				Between Point ⓔ (eR1, F-6000) & GND, DC Volt Meter	eT3 (F-6000)	1.0V ± 0.1V	
3.	1602kHz (or 1610kHz) Tuning Adj.	No Input	—	FL Display	TUNING UP, DOWN Button	1602kHz (or 1610kHz)	
				Between Point ⓔ (eR1, F-6000) & GND, DC Volt Meter	eTC3 (F-6000)	8.0V ± 0.1V	
4.	603kHz (or 600kHz) RF Adj.	603kHz (or 600kHz) ANT Input 55dB 400Hz (30% MOD.), AM SSG	AM ANT Terminal	FL Display	TUNING UP, DOWN Button	603kHz (or 600kHz)	
				Output L or R-ch, VTVM, SCOPE	eT1 (F-6000)	MAX. Output	
5.	1404kHz (or 1400kHz) RF Adj.	1404kHz (or 1400kHz) ANT Input 55dB 400Hz (30% MOD.), AM SSG	Same as above	FL Display	TUNING UP, DOWN Button	1404kHz (or 1400kHz)	
				Output L or R-ch, VTVM, SCOPE	eTC1 (F-6000)	MAX. Output	
6.	LOCKED Indicator Level Adj.	999kHz (or 1000kHz) ANT Input 60dB 400Hz (30% MOD.), AM SSG	Same as above	FL Display	TUNING UP, DOWN Button	999kHz (or 1000kHz)	
				LOCKED Indicator	eVR1 (F-6000)	LOCKED Indicator turns ON.	

2) LW Tuning Adjustment (T-1000L only)

Note: MW/LW switch LW

STEP	SUBJECT	FEED SIGNAL		MEASURE OUTPUT	ADJUST	ADJUST FOR	REMARKS
		FROM	TO				
1.	153kHz Tuning Adj.	No Input	—	Between Point ⓔ (eR1, F-6000) & GND DC Volt Meter	eT4 (F-6000)	1V ± 0.1V	•Repeat procedures as stated in subject 1 & 2.
2.	360kHz Tuning Adj.	No Input	—	Same as above	eTC4 (F-6000)	5.4V ± 0.1V	
3.	170kHz RF Adj.	170kHz ANT Input 30dB 400Hz (30% MOD.), AM SSG	AM ANT terminal	Output Terminal L-CH or R-CH VTVM & Scope	eT2 (F-6000)	Max. Output	
4.	300kHz RF Adj.	300kHz ANT Input 30dB 400Hz (30% MOD.), AM SSG	Same as above	Same as above	eTC2 (F-6000)	Max. Output	

5. PARTS LIST OF BOARD

Note

- Symbols, EG, EI, EF and EU in parts list specify the area.

symbol	area
EG	F.R. Germany
EI	Italy
EF	France
EU	Europe (Except F.R. Germany, Italy and France)

- Parts without these symbols can be used for all (EG, EI, EF and EU) area.

5-1. F-5724 PLL Synthesizer Control Board

< Stock No. 01123205 = T-1000L·EF/01112005 = T-1000L·EU/
01123408 = T-1000·EG/01123605 = T-1000·EI >

Parts No.	Stock No.	Description
•Transistor		
fQ2	46367101	2SC2603
	or 48058801	2SC1740S
fQ3	48230200	DTC124XS
•IC		
fIC2	48367800	TC9303AN-002
fXO1	07237700	Quartz Element NR-18 for T-1000L (EF)
	83004400	Quartz Element RX-005 for T-1000L (EU)
	83004400	Quartz Element RX-005 for T-1000 (EG)
	83004400	Quartz Element RX-005 for T-1000 (EI)
•Diode		
fD1 ~ 21	03117600	1S2473T77
	or 83000100	1N4148
fD24	03117600	1S2473T77
	or 83000100	1N4148
fD40	03117600	1S2473T77 (T-1000L)
	or 83000100	1N4148 (T-1000L)
oS1 ~ 16	46708100	Push SW., Memory 1 ~ 16
	or 83000300	Push SW.,
	or 83032400	Push SW.,
oS17	48240500	Tact SW., HI-BLEND
	or 83004000	Push SW.,
	or 83032600	Push SW.,
oS18	48240500	Tact SW., FM
	or 83004000	Push SW.,
	or 83032600	Push SW.,
oS19	48240500	Tact SW., AM (MW/LW)
	or 83004000	Push SW.,
	or 83032600	Push SW.,
oS20	48240500	Tact SW., TUNING UP
	or 83004000	Push SW.,
	or 83032600	Push SW.,
oS21	48240500	Tact SW., TUNING DOWN
	or 83004000	Push SW.,
	or 83032600	Push SW.,
oS22	48240500	Tact SW., TUNING MODE
	or 83004000	Push SW.,
	or 83032600	Push SW.,
oS23	46708100	Push SW., MEMORY
	or 83000300	Push SW.,
	or 83032400	Push SW.,
•Transistor		
sQ1, 2	46367101	2SC2603
	or 48058801	2SC1740S

Parts No.	Stock No.	Description
sFL1	48182610	FL. Display Tube FG78M1
	or 83003400	FL. Display Tube 7-MT-79G
sLD1	48835400	SEL2910A, HI-BLEND
sLD2	48835400	SEL2910A, AUTO
sLD3	48835400	SEL2910A, LOCKED
sLD4	48835400	SEL2910A, STEREO
sC2	48103400	1 μ F 50V E.B.

5-2. F-6000 Main Board < Stock No. 01123305 = T-1000L·EF/ 01112105 = T-1000L·EU/01123508 = T-1000·EG/01123705 = T-1000·EI >

Parts No.	Stock No.	Description
dZ1	48729600	FM Frontend Pack
•Transistor		
dQ1	46393201	2SC2786
dQ3	46367101	2SC2603
	or 48058801	2SC1740S
dQ4	46540801	2SC2878
	or 46604301	2SC3327
dQ5	46367101	2SC2603
	or 48058801	2SC1740S
dQ6, 7	46367001	2SA1115
	or 48058601	2SA933S
dQ8	46367101	2SC2603
	or 48058801	2SC1740S
dQ9	46367001	2SA1115
	or 48058601	2SA933S
dQ10, 11	46367101	2SC2603
	or 48058801	2SC1740S
•FET		
dFT1	46643501	2SK163-K2
	or 46643502	2SK163-L1
	or 46643601	2SK117-Y
	or 46643602	2SK117-GR
•IC		
dIC1	48715100	LA1266
dIC2	48491000	LA3410A
dXO1	48272800	Ceramic OSC Element CSB456
	or 83000200	Ceramic OSC Element
•Diode		
dD3 ~ 13	03117600	1S2473T77
	or 83000100	1N4148
dC22	48102400	4.7 μ F 25V E.B.
dC33	48103400	1 μ F 50V E.B.
dC35	48102400	4.7 μ F 25V E.B.
dCF1, 2	46202500	Ceramic Filter SFE10.7MS2 (T-1000L)
	or 83000000	Ceramic Filter SFE10.7MS2 (T-1000L)
	48064800	Ceramic Filter SFE10.7MS3G (T-1000)
	or 83043800	Ceramic Filter SFE10.7MS3G (T-1000)

< F-6000 >

Parts No.	Stock No.	Description
dT1	48718700 83005900 83005900 83005900	FM IF Coil for T-1000L (EF) FM IF Coil for T-1000L (EU) FM IF Coil for T-1000 (EG) FM IF Coil for T-1000 (EI)
dT2	48718600 83006000 83006000 83006000	FM IF Coil for T-1000L (EF) FM IF Coil for T-1000L (EU) FM IF Coil for T-1000 (EG) FM IF Coil for T-1000 (EI)
dT3	48791700	CH Filter (T-1000)
dT4	49344800 or 83006600 or 83049300	Low Pass Filter Low Pass Filter Low Pass Filter
dT5	49324300	FM VHF Balwn (T-1000L)
dVR1	07241600 or 83007500	100k Ω (B) S.V.R., } FM Locked Ind. 100k Ω S.V.R., } Level Adj.
•Transistor		
eQ1, 2	46540801 or 46604301	2SC2878 (T-1000L) 2SC3327 (T-1000L)
eQ3, 4	46367101 or 48058801	2SC2603 (T-1000L) 2SC1740S (T-1000L)
•FET		
eFT1	46393000 or 46393001	2SK192A-Y 2SK192A-GR
•Diode		
eD1	46146300	KV1236Z2 (Variable Capacitance)
eD2	03117600 or 83000100	1S2473T77 1N4148
eTC1	46095700 or 46162900	Trimmer Capacitor 30pF Trimmer Capacitor 30pF
eTC2	46095700 or 46162900	Trimmer Capacitor 30pF (T-1000L) Trimmer Capacitor 30pF (T-1000L)
eTC3	46095700 or 46162900	Trimmer Capacitor 30pF Trimmer Capacitor 30pF
eTC4	46095700 or 46162900	Trimmer Capacitor 30pF (T-1000L) Trimmer Capacitor 30pF (T-1000L)
eCF1	48069900	Ceramic Filter CFM2-450BL
eL1	46091910 or 83020300	Inductor 39mH Inductor 39mH
eT1	46394600 or 49323900 or 83005600 or 83048000	AM ANT Coil AM ANT Coil AM ANT Coil AM ANT Coil
eT2	48577500 or 49324000 or 83045300 or 83048100	LW ANT Coil (T-1000L) LW ANT Coil (T-1000L) LW ANT Coil (T-1000L) LW ANT Coil (T-1000L)
eT3	48568800 or 49324100 or 83005700 or 83048200	AM OSC Coil AM OSC Coil AM OSC Coil AM OSC Coil
eT4	48074410 or 49324200	LW OSC Coil (T-1000L) LW OSC Coil (T-1000L)
eT5	48072000 or 49323800 or 83013400 or 83047900	AM IF Coil AM IF Coil AM IF Coil AM IF Coil
eVR1	07241500 or 83007400	50k Ω (B) S.V.R., } AM Locked Ind. 50k Ω S.V.R., } Level Adj.
•Transistor		
fQ10	46367101 or 48058801	2SC2603 2SC1740S
fQ11	46367101 or 48058801	2SC2603 (T-1000L) 2SC1740S (T-1000L)
•FET		
fFT1	46643501 or 46643502 or 46643601 or 46643602	2SK163-K2 2SK163-L1 2SK117-Y 2SK117-GR

< F-6000 >

Parts No.	Stock No.	Description
fFT2	46643501 or 46643502 or 46643601 or 46643602	2SK163-K2 (T-1000L) 2SK163-L1 (T-1000L) 2SK117-Y (T-1000L) 2SK117-GR (T-1000L)
•IC		
fIC1	49295600	TC9182P
•Diode		
fD51 ~ 53	03117600 or 83000100	1S2473T77 1N4148
Δ fR50	46228800	68 Ω 1/2 W N.I.R.
fC20	48485800	4700 μ F 6.3V E.C.
fC25	48103500	2.2 μ F 50V E.B.
fC27	48103400	1 μ F 50V E.B.
•Transistor		
mQ1	46367101 or 48058801	2SC2603 2SC1740S
Δ mQ2, 3	03083901 or 46546701	2SD313HP 2SD880
Δ mQ4	46367001 or 48058601	2SA1115 2SA933S
•Diode		
Δ mD1 ~ 8	03117700 or 83005000	10E-2 1N4002
Δ mD9, 10	03117600 or 83000100	1S2473T77 1N4148
•Zener Diode		
mDZ1	46828000 or 49306000	RD15E-B1 05AZ15-X
mDZ2	46825500 or 49303500	RD6.8E-B1 05AZ6.8-X
mDZ3	46829600 or 49307600	RD22E-B4 05AZ22-R
Δ mR6	46227600	6.8 Ω 1/2W N.I.R.
Δ mR7	46249600	180 Ω 1W N.I.R.
Δ mR11	46229500	270 Ω 1/2W N.I.R.
mC8	48103500	2.2 μ F 50V E.B.
Δ mC16	48733500	0.01 μ F 400V C.C.
Δ mS1	48847800 or 83004200	Push SW., POWER Push SW., POWER
•Transistor		
oQ1	46367101 or 48058801	2SC2603 (T-1000L) 2SC1740S (T-1000L)
oQ2	46367001 or 48058601	2SA1115 (T-1000L) 2SA933S (T-1000L)
oQ3	46367101 or 48058801	2SC2603 (T-1000L) 2SC1740S (T-1000L)
oQ4	46367001 or 48058601	2SA1115 2SA933S
oQ5	46367101 or 48058801	2SC2603 2SC1740S
oQ6	46367001 or 48058601	2SA1115 2SA933S
oQ7	46367101 or 48058801	2SC2603 2SC1740S
oQ8	46367101 or 48058801	2SC2603 2SC1740S
oQ9	46367001 or 48058601	2SA1115 2SA933S
•Diode		
oD1, 2	03117600 or 83000100	1S2473T77 (T-1000L) 1N4148 (T-1000L)
oD3, 4	03117600 or 83000100	1S2473T77 1N4148
oZ3	48313900 or 83044700	10P ST Socket, System Control 10P ST Socket, System Control
oZ2	48528400	2P Pin Jack Terminal, OUTPUT
oZ1	46547300 46410200	4P Antenna Terminal (T-1000L) 2P Antenna Terminal (T-1000)
•LED		
sLD5	48849300	SEL3913K

6. OTHER PARTS

•Front View

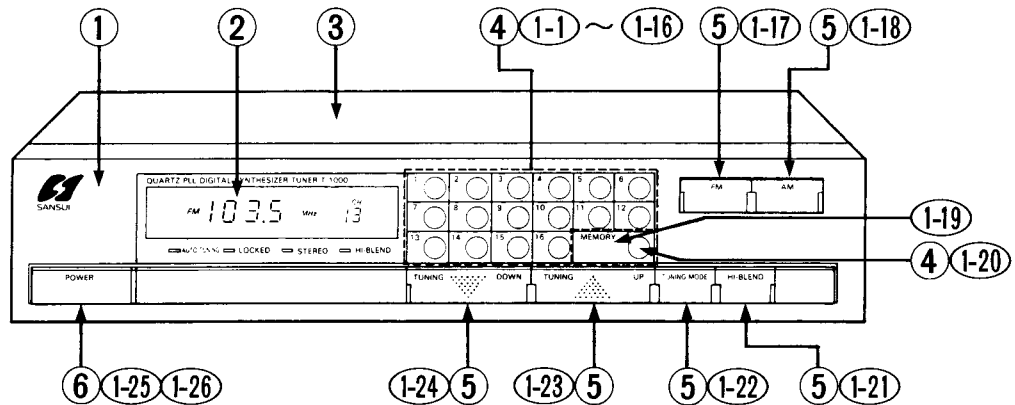

•Top View

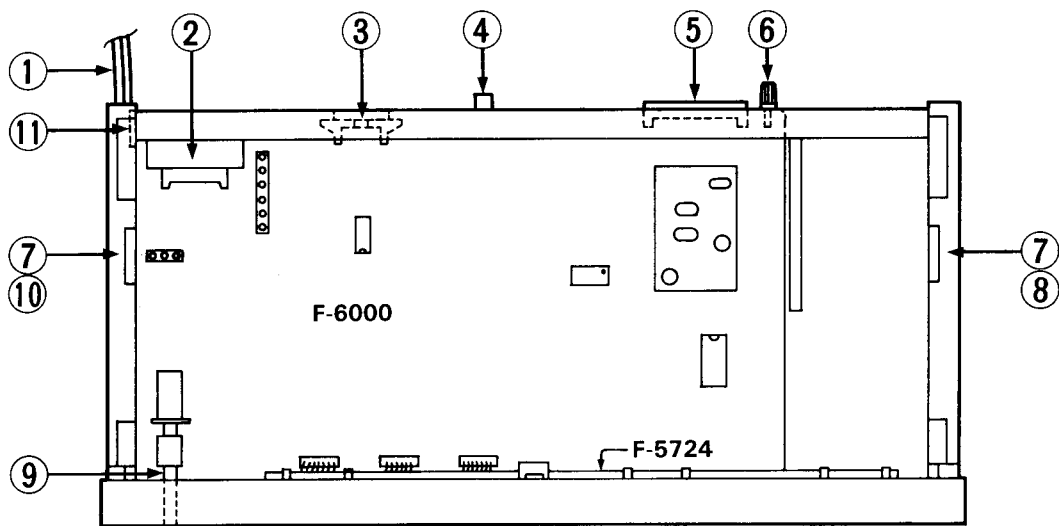

Parts List <Front View>

Parts No.	Stock No.	Description
1	37504201	Front Panel Ass'y (T-1000)
	37502905	Front Panel Ass'y (T-1000L)
1-1	84568800	1•Knob
1-2	84568900	2•Knob
1-3	84569000	3•Knob
1-4	84569100	4•Knob
1-5	84569200	5•Knob
1-6	84569300	6•Knob
1-7	84569400	7•Knob
1-8	84569500	8•Knob
1-9	84569600	9•Knob
1-10	84569700	10•Knob
1-11	84569800	11•Knob
1-12	84569900	12•Knob
1-13	84570000	13•Knob
1-14	84570100	14•Knob
1-15	84570200	15•Knob
1-16	84570300	16•Knob
1-17	84568400	FM•Knob
1-18	84568500	AM•Knob (T-1000)
	84585300	MW/LW•Knob (T-1000L)
1-19	84566400	MEMORY Knob Cover
1-20	84567100	Knob, MEMORY
1-21	84563600	HI-BLEND•Knob
1-22	84563500	TUNING MODE•Knob
1-23	84568200	TUNING UP•Knob
1-24	84568300	TUNING DOWN•Knob
1-25	84567010	POWER•Knob
1-26	84505100	Spring, POWER•Knob
2	48182610	FG78M1 FL Display Tube
	or 83003400	7-MT-79GK FL Display Tube

Parts No.	Stock No.	Description
3	84504000	Bonnet
4	46708100	Push SW. } Memory 1~16•
	or 83000300	Push SW. } MEMORY
	or 83032400	Push SW. }
5	48240500	Push SW. } FM•AM (MW/LW)•
	or 83004000	Push SW. } HI-BLEND•TUNING MODE•
	or 83032600	Push SW. } TUNING UP•TUNING DOWN
△ 6	48847800	Push SW., POWER

Parts List <Top View>

Parts No.	Stock No.	Description
△ 1	49299300	Power Supply Cord
	or 83000600	Power Supply Cord
△ 2	15032705	Power Transformer
	or 83045405	Power Transformer
3	48313900	10P ST Socket } System Control
	or 83044700	10P ST Socket }
4	48528400	2P Pin Jack Terminal, OUTPUT
5	46410200	2P Antenna Terminal (T-1000)
	46547300	4P Antenna Terminal (T-1000L)
6	84528300	Ground Terminal
7	84527700	Leg Packing, Side Panel
8	84512200	Side Panel (R)
9	84502900	Joint Shaft, Power SW.
10	84512300	Side Panel (L)
11	84514000	AC Cord Cover

7. PARTS LOCATION ON BOARD

7-1. F-6000 Main Board
Component Side

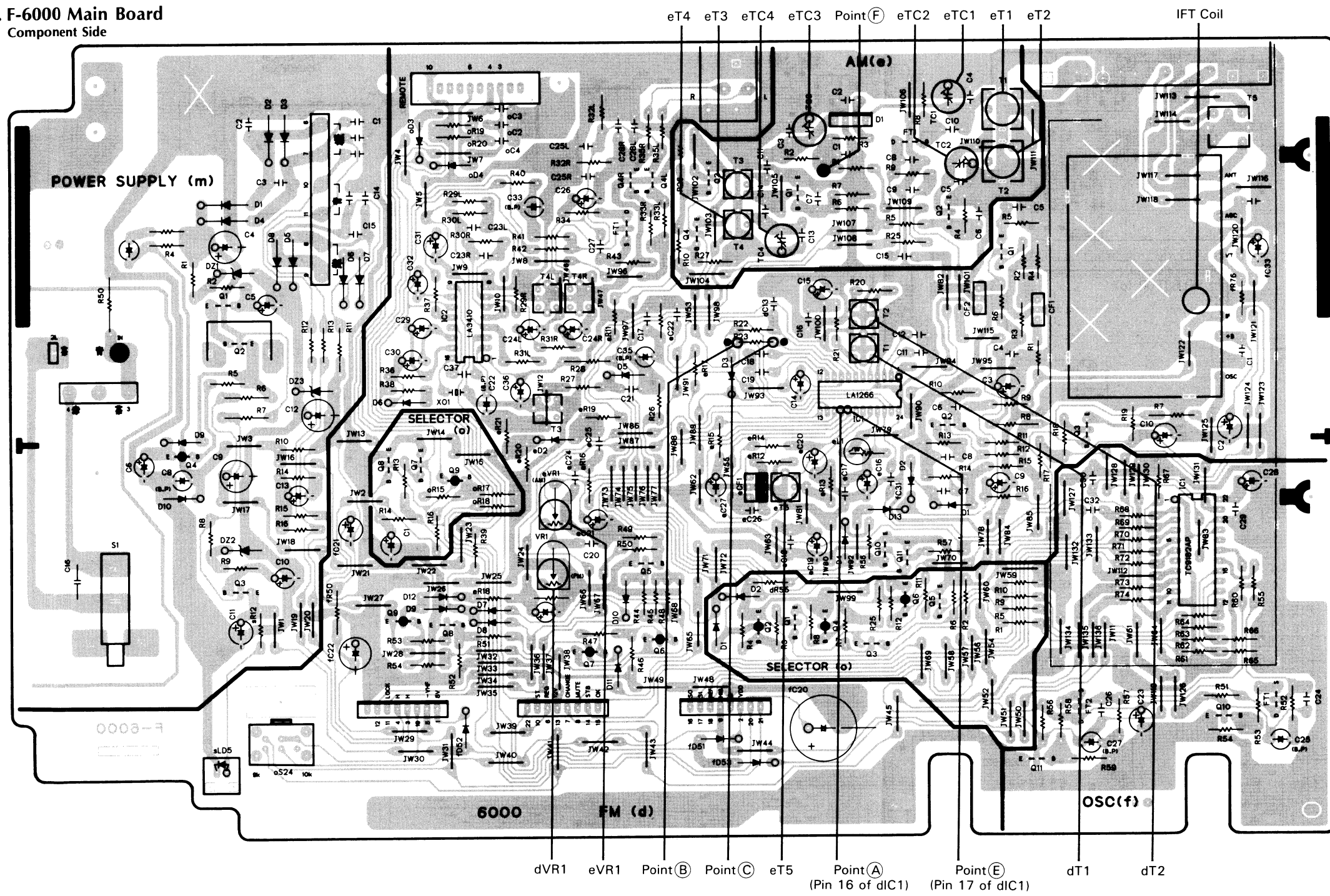

7-2. F-5724 PLL Synthesizer Control Board
Component Side

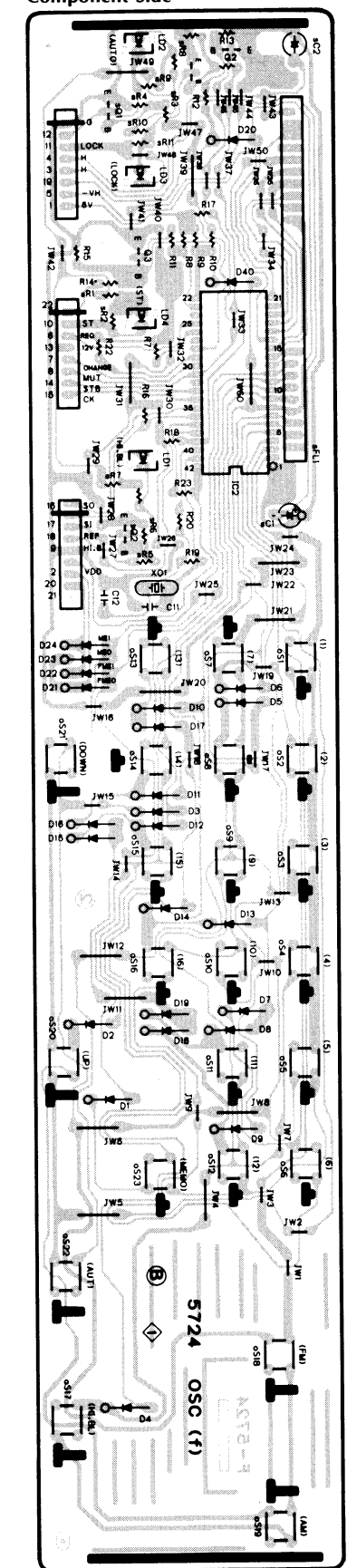

8. SCHEMATIC DIAGRAM 8-1. T-1000

• Design and specifications subject to change without notice for improvement.
 • La présentation et les spécifications sont susceptibles d'être modifiées sans préavis par suites d'améliorations éventuelles.
 • Änderungen, die dem technischen Fortschritt dienen, bleiben vorbehalten.

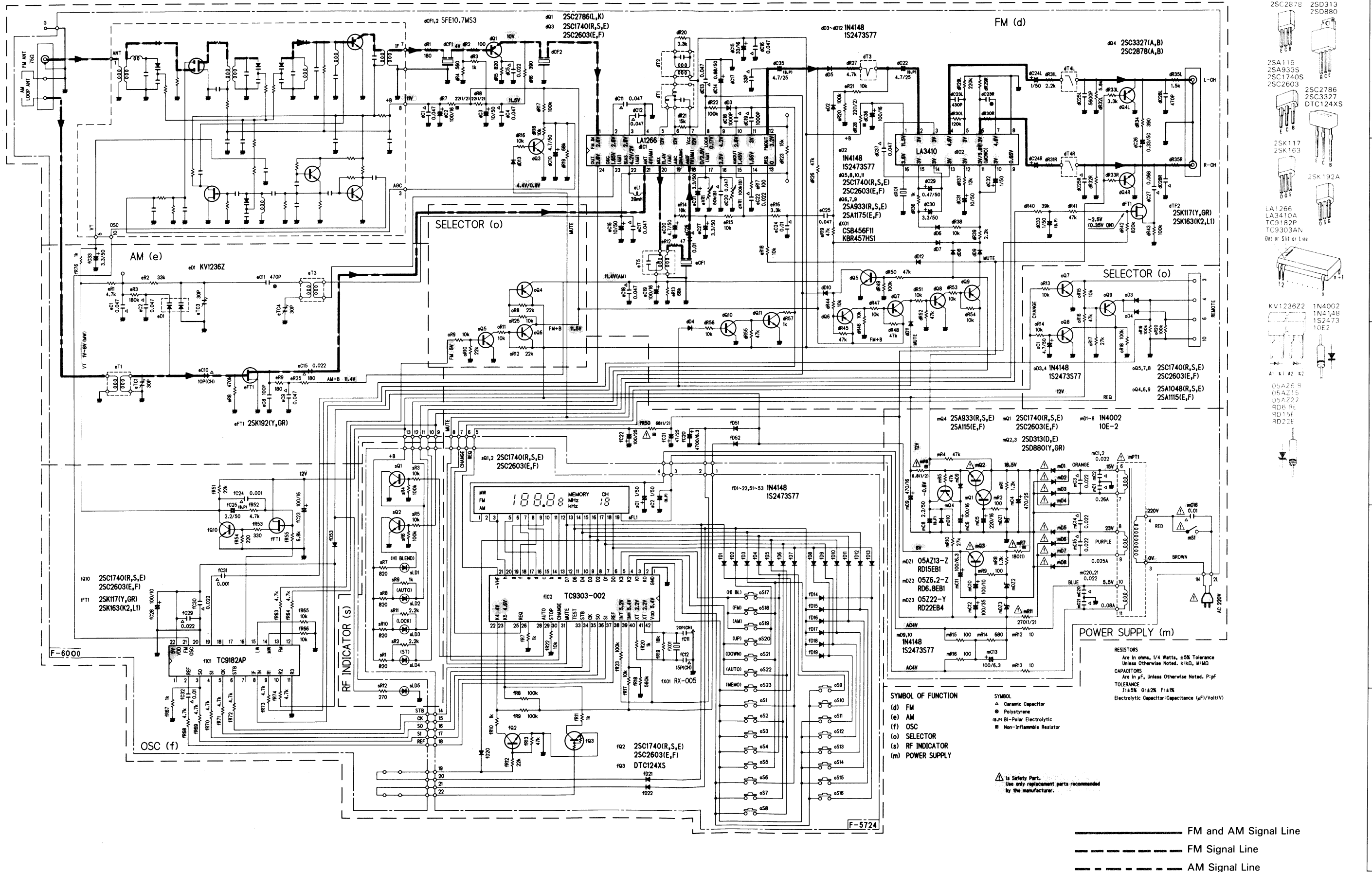

- 2SC2878
- 2SD313
- 2SD880
- 25A115
- 25A933S
- 25C1740S
- 25C2603
- 2SC2786
- 25C3327
- DTC124XS
- 2SK117
- 2SK163
- 2SK192A
- 2SK192A
- LA1266
- LA3410A
- TC9182P
- TC9303AN
- Det. or. Slot or Line
- KV123622
- IN4002
- IN4148
- 1S2473
- 10E2
- A1 K1 K2 K3
- 05A26-B
- 05A215
- 05A222
- RD6-RE
- RD11F
- RD22E

T-1000/100L T-1000/100L

A B C D E F G H

8-2. T-1000L

* Design and specifications subject to change without notice for improvement.
 * La présentation et les spécifications sont susceptibles d'être modifiées sans préavis par suites d'améliorations éventuelles.
 * Änderungen, die dem technischen Fortschritt dienen, bleiben vorbehalten.

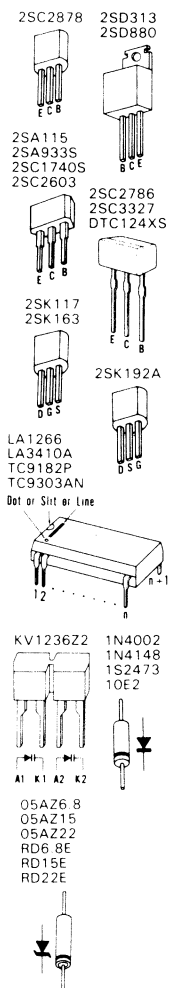
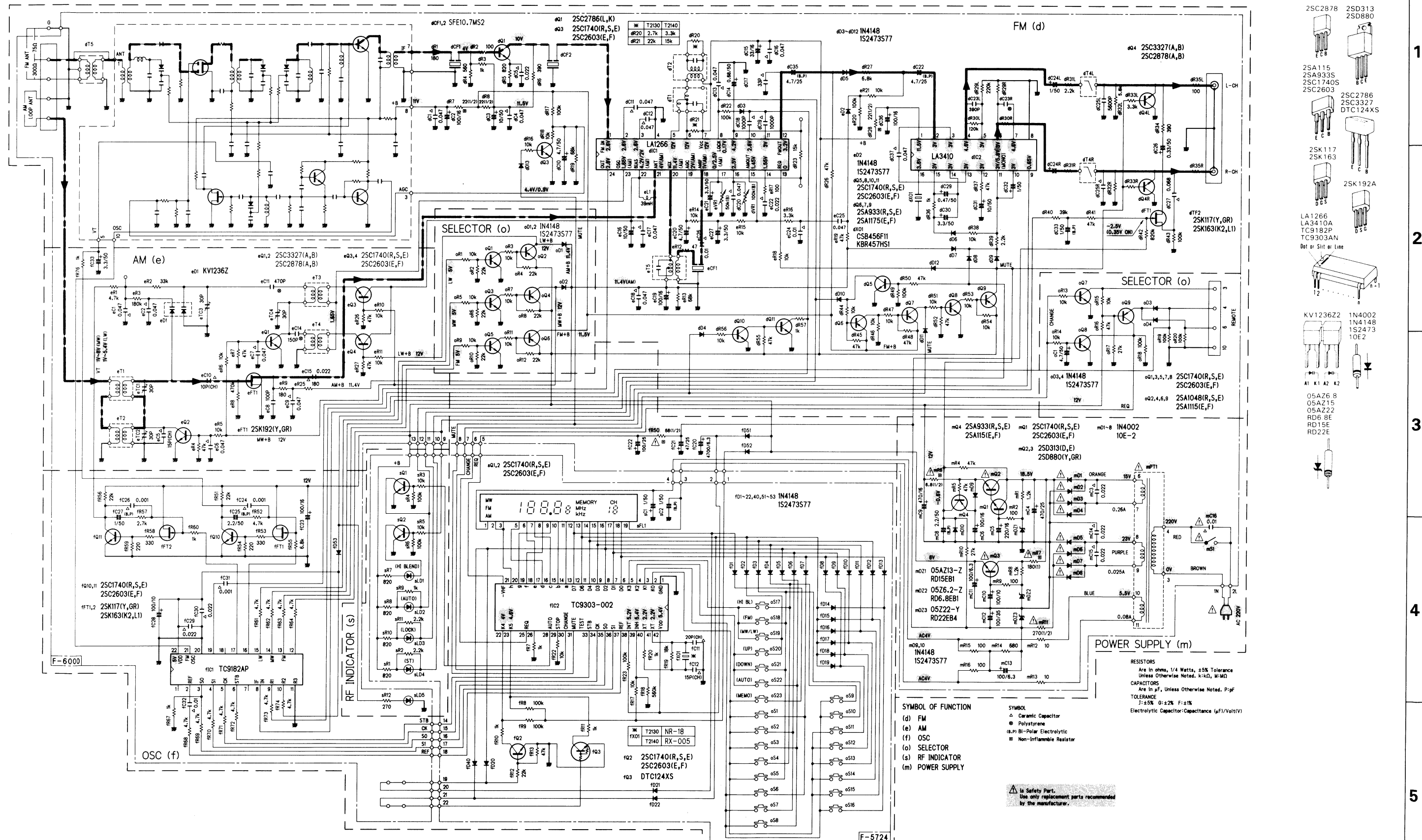

SYMBOL OF FUNCTION
 (d) FM
 (e) AM
 (f) OSC
 (o) SELECTOR
 (s) RF INDICATOR
 (m) POWER SUPPLY

SYMBOL
 Δ Ceramic Capacitor
 ⊕ Polystyrene
 ⊖ Bi-Polar Electrolytic
 ■ Non-Inflammable Resistor

⚠ Safety Part.
 Use only replacement parts recommended by the manufacturer.

RESISTORS
 Are in ohms, 1/4 Watts, ±5% Tolerance
 Unless Otherwise Noted. k:kΩ, M:MΩ
 CAPACITORS
 Are in μF, Unless Otherwise Noted. P:pF
 TOLERANCE
 J:±5% O:±2% F:±1%
 Electrolytic Capacitor:Capacitance (μF)/Voltage(V)

————— FM and AM (MW/LW) Signal Line
 - - - - - FM Signal Line
 - - - - - AM (MW/LW) Signal Line

1
2
3
4
5

9. INTERIOR BLOCK DIAGRAM AND TERMINAL FUNCTION OF IC

•LA1266 (FM IF, AM RF-MIX-IF)

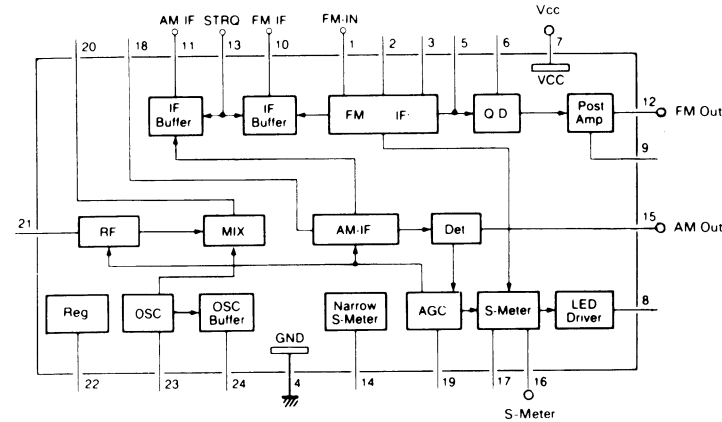

•LA3410 (MPX)

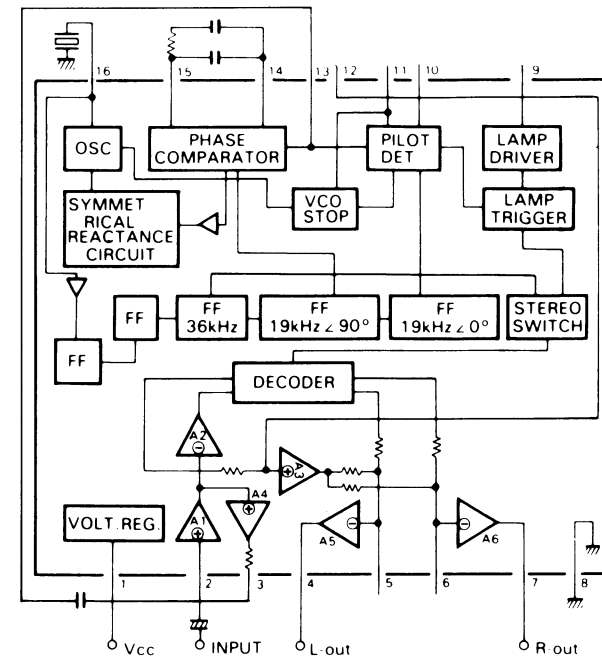

•TC9182P (PLL Synthesizer)

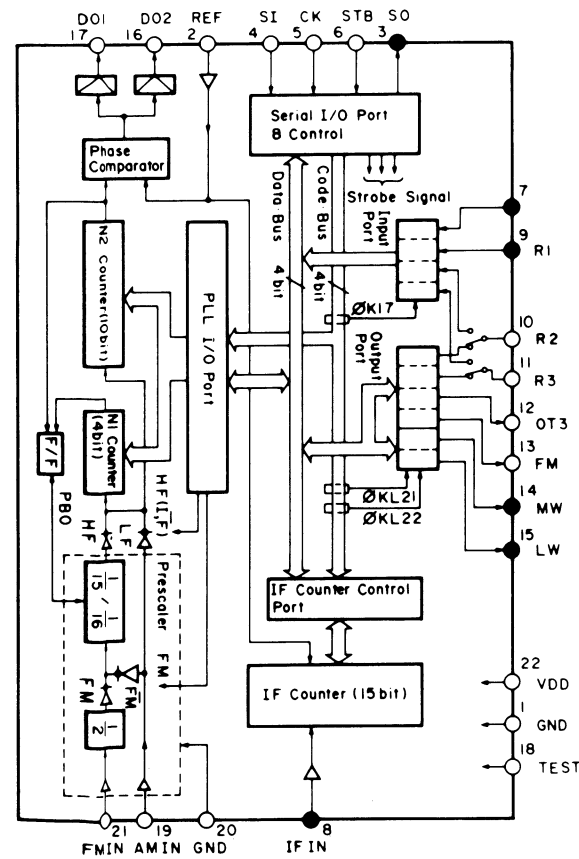

◆ Terminal Function <TC9182P>

Pin No.	Symbols on substrate	Functions
2	REF	Reference frequency signal input terminal
3	SO	Serial data output terminal
4	SI	Serial data input terminal
5	CK	Clock signal input terminal
6	STB	Strobe signal input terminal
8	IFIN	Terminal to input IF signal for performing the automatic search stop.
9	R1	Terminals to input signals from the remote controller.
10	R2	
11	R3	7-kind key input instructions are available in combination with TC-9303N-002.
13	FM	Band selector signal output terminal
14	MW	
15	LW	
16	DO ₂	Terminals to output a signal from a phase comparator.
17	DO ₁	
18	TEST	Terminal to input a signal of test mode.
19	AMIN	Terminal to input a signal from the AM local OSC.
20	GND	Ground terminal for prescaler
21	FMIN	Terminal to input a signal from the FM local OSC.
22	VDD	Power supply terminals. 5V ± 0.5V
1	GND	Ground terminal

◆ Terminal Function of TC9303N <Tuning Controller>

Pin No.	Pin Name	Input/Output	Description
2~7 22,23	K0~K3 K4,K5	Input	Ports for inputting a key matrix signal. On the other hand, key return timing signals are outputted from output parts DO~D7.
6~12	D0~D7	Output	Ports for outputting digit signals to FL display and a key return signal source.
13~20	a~h	Output	Ports for outputting segment signals to FL display.
21	-VFL	-	Terminal for a device supply - voltage.
25	REQ.	Input	Terminal for inputting a request signal for remote controller. When a "H" level signal is applied, remote control data is accepted.
28	AUTO	Output	Terminal for outputting LED driver signal for indicating AUTO during auto search tuning operation. "H" level when active.
29	STOP	Input	Terminal to input a signal for performing the automatic search stop. When a "H" level signal is applied during automatic search operation, the scanning operation stop.
30	CHANGE	Output	Terminal for outputting a changing signal. (For Computer selector signal) In changing, the terminal becomes a "H" level signal. Changing signal is outputted in the following cases: 1. When INH changes from "L" to "H". 2. When each input key is depressed normally. 3. When a band key corresponding to the presently received band is depressed. 4. When remote control REQUEST changes to "H" (inclusive NOP.)
30	CHANGE	Output	2. When each input key is depressed normally. 3. When a band key corresponding to the presently received band is depressed. 4. When remote control REQUEST changes to "H" (inclusive NOP.)
31	MUTE	Output	Terminal to output the muting signal. The kept in "L" level in ordinary state, and in "H" level in muting. The muting signal is outputted in the following. •When "INH" terminal changes from "L" to "H". •When band is switched. •When memory is accessed (in the same band). •In FM manual tuning. •In MW and LW manual tuning. •In AUTO-tuning stop. •When "INH" terminal changes from "H" to "L".

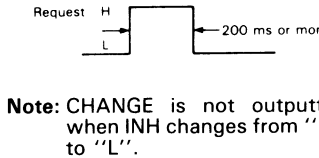

Pin No.	Pin Name	Input/Output	Description
32	TEST	Input	Terminal for inputting a test mode control signal. The device is returned to the ordinary operation at "L" level or NC status. This terminal is fixed at "L" level usually.
33	STB	Output	Serial interfaces for STB (strobe pulse output), CD (serial clock output), SO (serial data output) and SI (serial data input). TC9182P PLL IC is controlled by executing SIO instruction.
34	CK	Output	
35	SO	Output	
36	SI	Input	
37	REF	Output	Terminal for outputting a reference frequency signal supplied to TC9182P PLL IC. Note: This output is fixed at "L" level automatically when INH input is at "L" level.
38	INT	Input	Terminal for inputting a system resetting signal to device. When INT is at "L" level, the device is reset; when at "H" level, program starts beginning from address No.0. This terminal is usually fixed at "H" level, because the device is reset when a voltage of 4.5V is applied to VDD. (power-on reset)
39	INH	Input	Port for inputting a radio mode selection signal. Radio-on mode is set at "H" level; radio-off mode is set at "L" level. When this terminal at "L" level, the REF output is fixed at "L" level automatically.
40	X _T	-	Terminals for connecting a quartz oscillator of 7.2 MHz.
41	X _T	-	
42	VDD	-	Terminal for applying a device supply voltage. In the normal operation, a voltage of 5V ± 10% is applied; but in back-up condition, the voltage can be reduced to 2V. Further, when a voltage of 4.5V is applied to this terminal, the device is reset and then program start beginning from address No.0 (power-on reset).



SANSUI ELECTRIC CO., LTD.:
SANSUI ELECTRONICS CORPORATION:
SANSUI ELECTRONICS G.M.B.H.:
山水電気株式会社

14-1, Izumi 2-chome, Suginami-ku Tokyo 168 Japan
PHONE: (03) 324-8891/TELEX: 232-2076 (International Division)
1250 Valley Brook Ave. Lyndhurst, N.J. 07071 U.S.A.
17150 South Margay Ave. Carson, California 90746 U.S.A.
3036 Koapaka Street, Honolulu, Hawaii 96819 U.S.A.
Paul Ehrlich Strasse 8, 6074 Rödermark 2, West Germany

東京都杉並区和泉2-14-1 (〒168)

(SM2-77)

Printed in Japan (1988.06.M) <Stock No. 36539500>



März 1989

An alle
Servicestationen

Aufnahmepegel zu gering / System 1000
(T-1000/G-1000/B-1000/D-1000)
hier: T-1000

Fehler: Bei den Geräten ist der Aufnahmepegel
des Tunersignals nicht aussteuerbar;
hier: Tuner T-1000

Grund: Fehl↔anpassung im Netzwerk

Abhilfe: C23 (390 pF) auf 270 pF ändern
(linker u rechter Kanal)

R30 (150 KOhm) auf 180 KOhm ändern
(linker u. rechter Kanal)

Merke: Diese Änderung bewirkt eine Erhöhung
des Ausgangspegels um 3 dB

Es müssen in die Geräte T-100/C-1000
eines Systems gleichzeitig geändert
werden.

Sansui Electronics GmbH

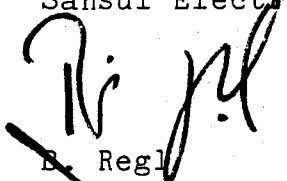
B. Regl.
Kundendienstleiter

