

SERVICE MANUAL

DC INTEGRATED TUNER AMPLIFIER

SANSUI TA-300/500

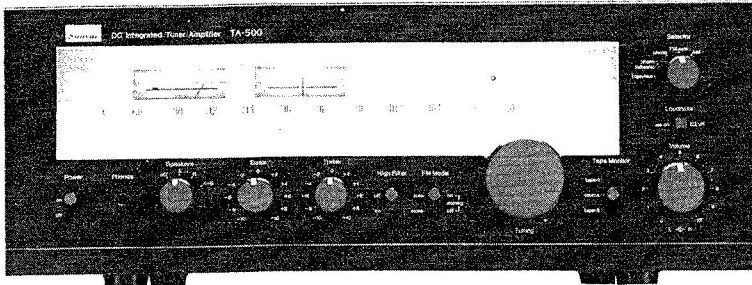

Sansui

SANSUI ELECTRIC CO., LTD.

SPECIFICATIONS

• Audio section

Power output
 <TA-300>
 Min. RMS, both channel driven, from 20 to 20,000 Hz,
 with no more than 0.06 % total harmonic distortion.
 30 watts per channel into 8 ohms
 <TA-500>
 Min. RMS, both channel driven, from 20 to 20,000 Hz,
 with no more than 0.05 % total harmonic distortion.
 50 watts per channel into 8 ohms

Load impedance 8 ohms
 Total harmonic distortion
 <TA-300> less than 0.06 % at or below rated
 min. RMS power output
 <TA-500> less than 0.05 % at or below rated
 min. RMS power output

Intermodulation distortion (70 Hz : 7 kHz = 4:1 SMPTE
 method)
 <TA-300> less than 0.06 %
 <TA-500> less than 0.05 %

Frequency response (at 1 watt)
 10 to 50,000 Hz +1 dB -3 dB

RIAA curve deviation (PHONO)
 +0.5 dB -0.5 dB
 (30 to 15,000 Hz)

Damping factor 40 into 8 ohms
 Input sensitivity and impedance (1 kHz, for rated power
 output)

PHONO 2.5 mV/47 kilohms
 (Max. input capability: 210 mV at 1 kHz, less than
 0.5 % total harmonic distortion)
 TAPE/AUX, TAPE 150 mV/47 kilohms

Output level (1 kHz)
 TAPE REC 150 mV/47 kilohms
 Channel separation (1 kHz)
 PHONO 50 dB
 TAPE/AUX 50 dB

Hum and noise (short-circuit, A-network)
 PHONO 75 dB
 TAPE/AUX 95 dB

Controls
 BASS ±10 dB (50 Hz)
 TREBLE ±10 dB (10 kHz)
 LOUDNESS (-30 dB)
 8 dB at 50 Hz
 6 dB at 10 kHz

• FM section

Tuning range 88 to 108 MHz
 Usable sensitivity
 Mono IHF 10.8 dBf (1.9 μV)
 DIN 1.2 μV
 Stereo IHF 19.0 dBf
 50 dB Quieting sensitivity
 Mono 15 dBf
 Stereo 38 dBf
 Signal to noise ratio (at 65 dBf)
 Mono 75 dB
 Stereo 70 dB
 Distortion (at 65 dBf)
 Mono less than 0.18 % at 100 Hz
 less than 0.10 % at 1,000 Hz
 less than 0.25 % at 6,000 Hz
 Stereo less than 0.3 % at 100 Hz
 less than 0.15 % at 1,000 Hz
 less than 0.30 % at 6,000 Hz

Alternate channel selectivity (at 400 kHz)
 50 dB
 Capture ratio 1.0 dB
 Image response ratio 55 dB (at 98 MHz)
 Spurious response ratio
 70 dB (at 98 MHz)
 Stereo separation 30 dB at 100 Hz
 40 dB at 1,000 Hz
 28 dB at 10,000 Hz
 Frequency response 30 to 15,000 Hz
 +0.5 dB -1.0 dB

Antenna input impedance
 300 ohms balanced
 75 ohms unbalanced

• AM section

Tuning range 530 to 1,600 kHz
 Usable sensitivity (Bar antenna)
 50 dB/m (300 μV/m)
 Selectivity 33 dB
 Signal to noise ratio 46 dB

Power requirements
 Power voltage 100, 120, 220, 240 V (50/60 Hz)
 For U.S.A. and Canada
 120 V (60 Hz)

Power consumption Rated
 <TA-300> 110 watts 135 VA
 <TA-500> 190 watts 230 VA
 Dimensions 430 mm (16-15/16") W
 160 mm (6-5/16") H
 399 mm (15-3/4") D

Weight
 <TA-300> 9.4 kg (20.7 lbs) net
 11.2 kg (24.7 lbs) packed
 <TA-500> 10.9 kg (24.0 lbs) net
 12.7 kg (28.0 lbs) packed

* Design and specifications subject to changes without
 notice for improvements.

1. BLOCK DIAGRAM

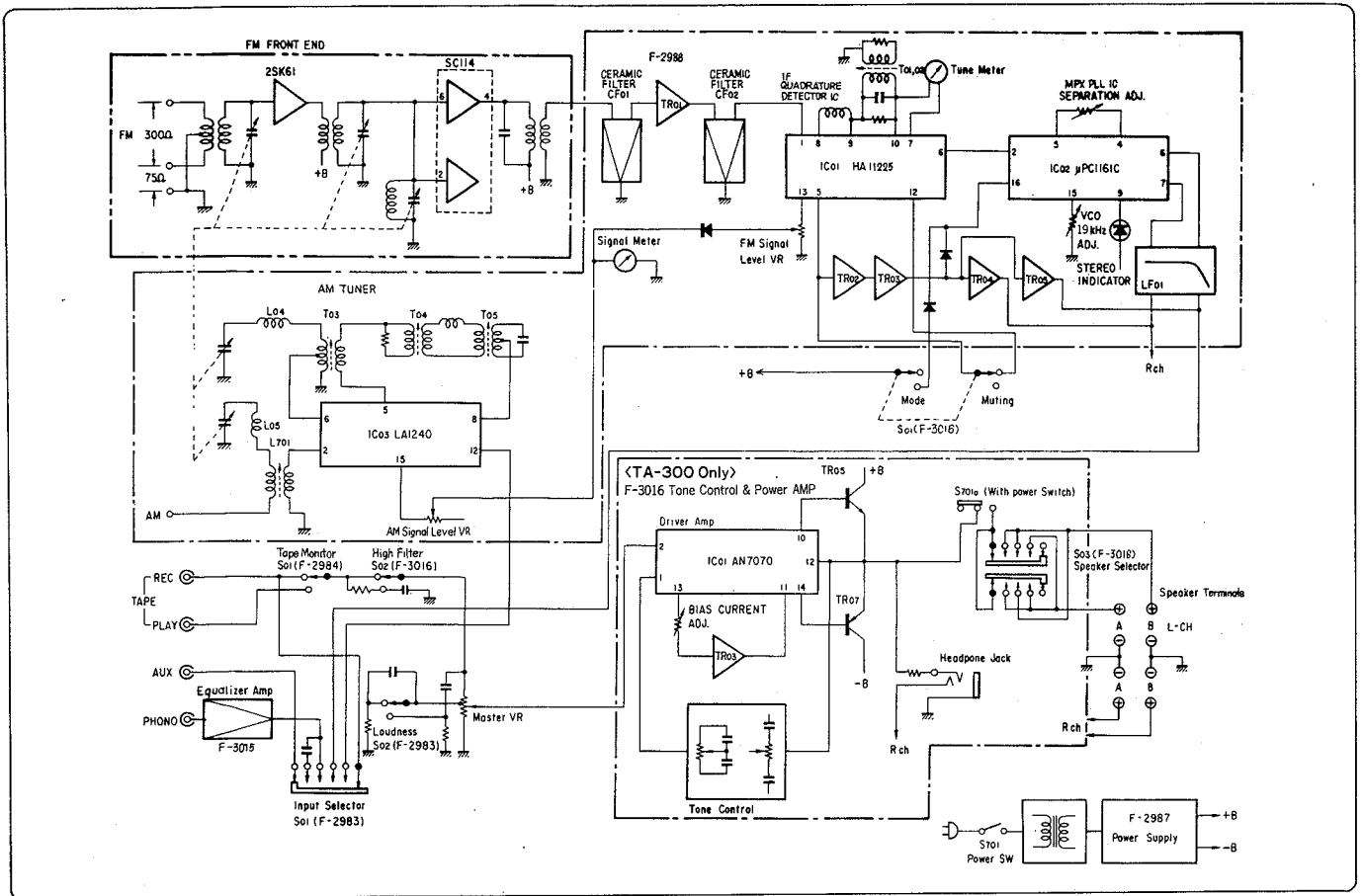

◇ F-3016 Tone Control & Power Amp <TA-500 Only>

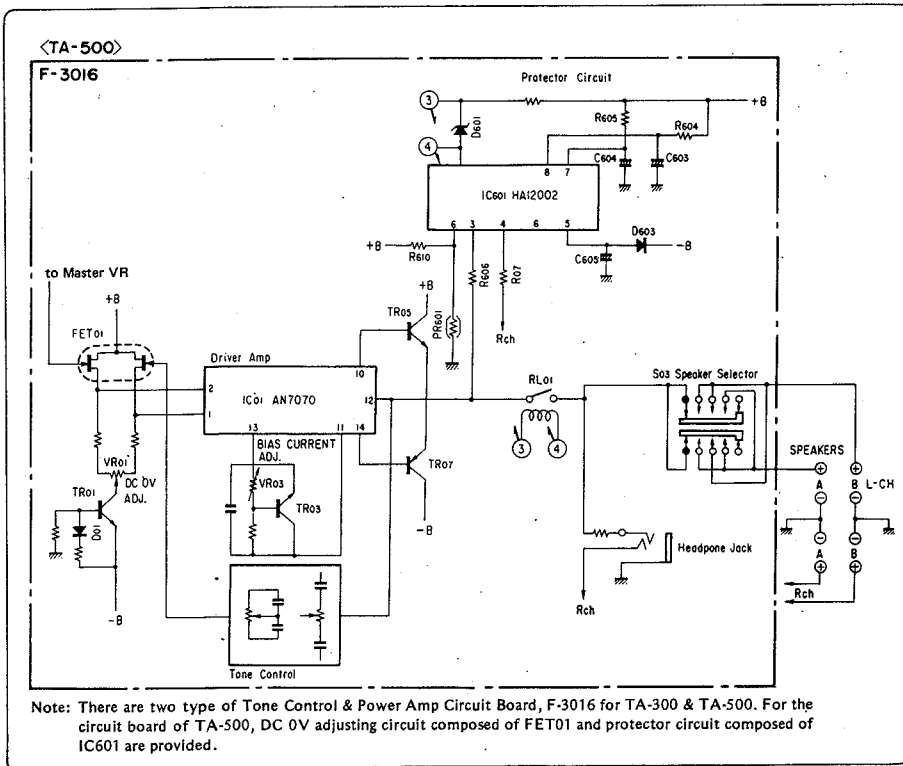

◇ Protector Circuit with IC HA12002

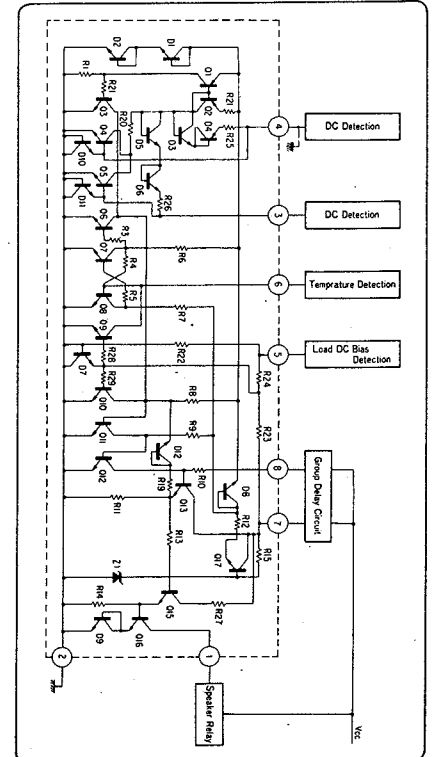

◇ Driver Amp Circuit with IC, AN7070

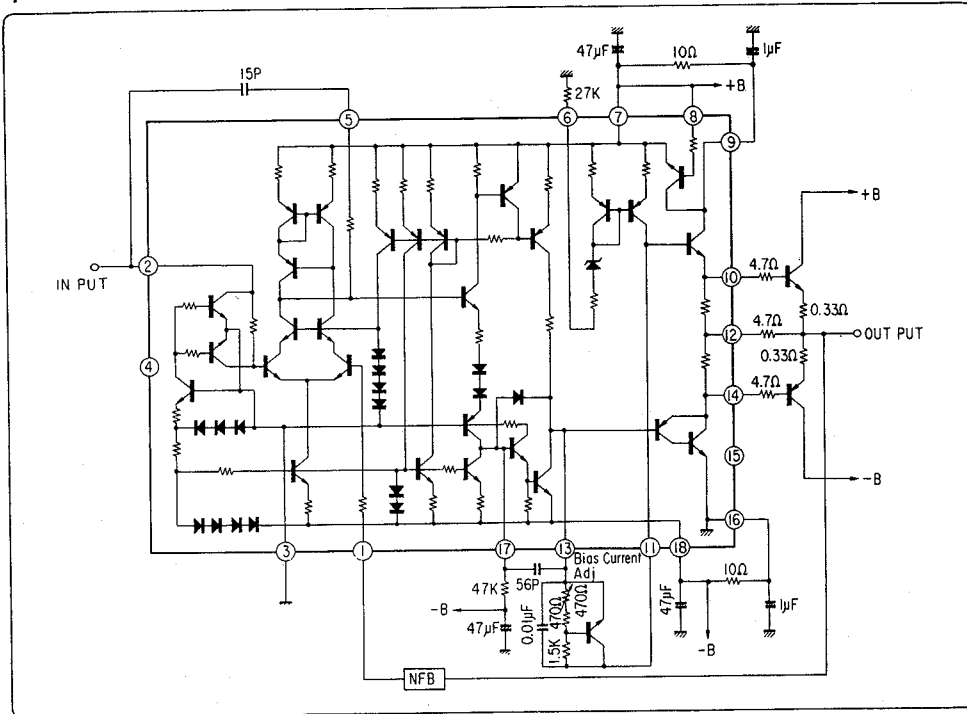

2. ADJUSTMENTS

2-1. Driver Circuit Board Adjustments (See Top View on page 7)

- Note: 1. Master Volume Minimum
 2. Room Temperature 18°C ~ 28°C
 (65°F ~ 83°F)
 3. For the adjustment, run the unit for more than 3 minutes after the power is switched on.

(1) DC 0V adjustment (TA-500 only)

	MEASURE OUTPUT	ADJUST	ADJUST FOR
L-CH	Between (+) and (-) of Speaker Terminal	VR01 F-3016	DC 0V
R-CH	Same as above	VR02 F-3016	DC 0V

(2) Bias Current adjustment

	MEASURE OUTPUT	ADJUST	ADJUST FOR
L-CH	Between emitters of TR05 and TR07	VR03 F-3016	DC 20 mV
R-CH	Between emitters of TR06 and TR08	VR04 F-3016	DC 20 mV

- Note: 1. By turning adjustment volumes, VR03 and VR04 counterclockwise, the bias current is decreased.
 2. In case of adjusting or confirming bias current, avoid such a measurement that the power transistors are heated.

2-2. FM Adjustment

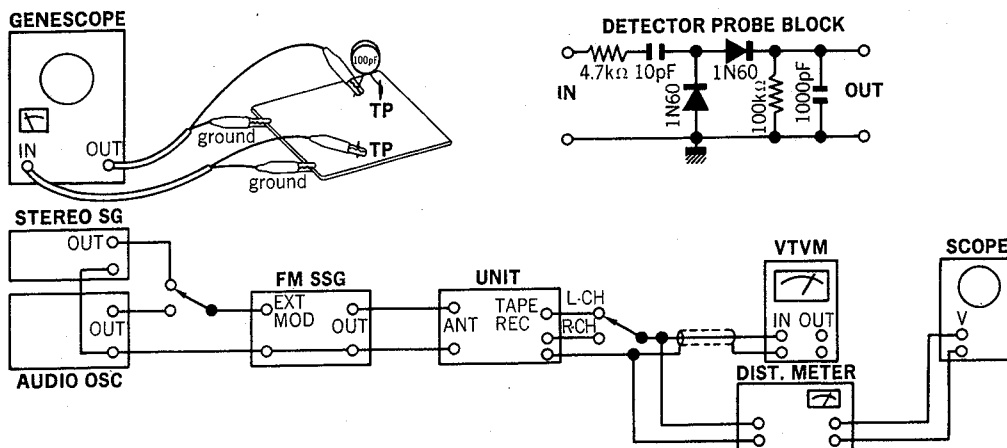

(1) FM IF, RF Adjustment and Dial Calibration (See Top View on page 7)

Note: 1. Selector FM AUTO
 2. FM Muting Switch OFF

3. Connection Connect the output of genescope to TC02 through 100 pF ceramic capacitor.

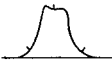
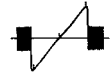
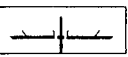
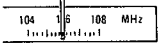
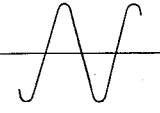
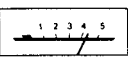
STEP	SUBJECT	FEED SIGNAL		MEASURE OUTPUT	ADJUST	ADJUST FOR	REMARKS
		FROM	TO				
1.	IF Coil	Output 80 dB Genescope	TC02 Front-end	lead wire of R11 F-2988 (Use Detector Probe)	IFT01	Max. IF waveform	
2.	Discriminator Coil	Same as above	Same as above	lead wire of R23 F-2988	T02 T01 F-2988	Steep linearity of S curve Make symmetrical S curve	
	Discriminator Coil in case of using Dist Meter	90 MHz ANT Input 65 dBf (59.8 dB) 1000 Hz (100% MOD) FM SSG	ANT terminal 300Ω	REC OUT L or R-CH Dist Meter	T01 T02 F-2988	Minimum THD	
3.	Tune Meter	Same as above	Same as above	Tune Meter	T01 F-2988	Center to Meter	
4.	106 MHz Dial Calibration	106 MHz ANT Input 65 dBf (59.8 dB) 1000 Hz (100% MOD) FM SSG	Same as above	REC OUT L or R-CH VTVM & Scope	TC03 Front-end	Max. Indication on signal meter & VTVM & Scope. Center Indication on Tune Meter	
5.	106 MHz RF Adj.	106 MHz ANT Input Minimum Value with sine wave 100 Hz (100% MOD) FM SSG	Same as above	Same as above	TC01, TC02 Front-end	Same as above	
6.	Signal Meter Volume	98 MHz ANT Input 65 dBf (59.8 dB) 1000 Hz (100% MOD) FM SSG	Same as above	Signal Meter ¹	VR01 F-2988	4.3 on Meter	



(2) FM STEREO Adjustment (See Top View on page 7)

Note: 1. Selector FM AUTO
 2. FM Mode Switch auto

STEP	SUBJECT	FEED SIGNAL		MEASURE OUTPUT	ADJUST	ADJUST FOR	REMARKS
		FROM	TO				
1.	PLL VCO Adj.	98 MHz ANT Input 65 dBf (59.8 dB) FM SSG Pilot 19 kHz (9% MOD) SUB 1 kHz + Pilot (100% MOD) STEREO SG	ANT terminal 300Ω	Stereo indicator	VR03 F-2988	Adjust the VR03 within center of lighting level	
	PLL VCO Adj. In case of using Freq. counter.	98 MHz ANT Input 65 dBf (59.8 dB) FM SSG (no MOD)	Same as above	lead wire of R39 F-2988 Use Freq. counter	VR03 F-2988	19 kHz ± 50 Hz	
2.	Separation	98 MHz ANT Input 65 dBf (59.8 dB) FM SSG Pilot 19 kHz (9% MOD) R Mode 1 kHz + Pilot (100% MOD) STEREO SG	Same as above	REC OUT L-CH VTVM & Scope	VR02 F-2988	OUT -40 dB	Confirm separation L-CH → R-CH

2-3. AM IF, RF Adjustment and Dial Calibration (See Top View on page 7)

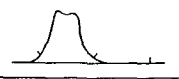
Note: 1. Selector AM
 2. Confirm start point of dial pointer before alignment.

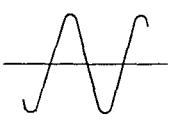
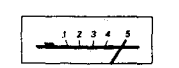
STEP	SUBJECT	FEED SIGNAL		MEASURE OUTPUT	ADJUST	ADJUST FOR	REMARKS
		FROM	TO				
1.	IF Coil	Genescope Output 80dB	TC04 Front-end	lead wire of R65 F-2988	T04 T05 F-2988	Max. IF waveform	
2.	600 kHz Dial Calibration	600 kHz ANT Input 60 dB 400 Hz (MOD 30%) AM SSG	AM ANT terminal	REC OUT L or R-CH VTVM & Scope	T03 F-2988	Max. Output	
	1400 kHz Dial Calibration	1400 kHz ANT Input 60 dB 400 Hz (MOD 30%) AM SSG	Same as above	Same as above	TC04 F-2988	Same as above	
3.	600 kHz RF Adj.	600 kHz ANT Input 60 dB 400 Hz (MOD 30%) AM SSG	Same as above	Same as above	L701 Bar Antenna	Same as above	
	1400 kHz RF Adj.	1400 kHz ANT Input 60 dB 400 Hz (MOD 30%) AM SSG	Same as above	Same as above	TC05 F-2988	Same as above	
4.	Signal Meter volume	1000 kHz ANT Input 100 dB 400 Hz (MOD 30%) AM SSG	Same as above	Signal Meter	VR04 F-2988	5 on meter	
5.	9 kHz WHISTLE FILTER	1000 kHz ANT Input 80 dB 9 kHz (MOD 30%) AM SSG	Same as above	REC OUT L or R-CH VTVM & Scope	T06 F-2988	Min. Output	

NEW MEASUREMENT FOR FM.

Input signal level under the provision of IHFM-T200, a new measurement method is indicated by available power ratio "dBf". To obtain approximate available power ratio "dBf", abstract 0.8 from attenuater indication of general FMSG (open load indication type); however, the former measurement, IHFM-T-100 is designated together too.

The way of modulation on IHFM-T-200 is shown below.

	modulation frequency	modulation mode	modulation factor
FM MONO	1000 Hz		100%
FM STEREO	1000 Hz	SUB	Pilot 9% Pilot + SUB 100%

The relation between the standard input 65 dBf of IHFM-T-200 and the former indication "dB" is shown below.

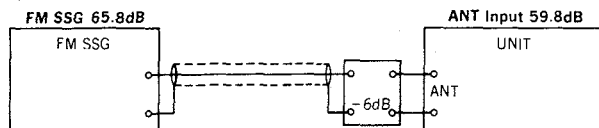

Abbreviations

Equipment	
AM FM Generator Oscilloscope	Genescope
AM Standard Signal Generator	AM SSG
FM Standard Signal Generator	FM SSG
FM Stereo Generator	Stereo SG
Oscilloscope	Scope
Audio Oscillator	Audio Osc.
Distortion Meter	Dist Meter
Others	
Antenna	ANT.
Modulation	MOD.
Total Harmonic Distortion	T.H.D.

3. PARTS LOCATION & PARTS LIST

3-1. F-2988 Tuner Circuit Board (Stock No. 7522151)

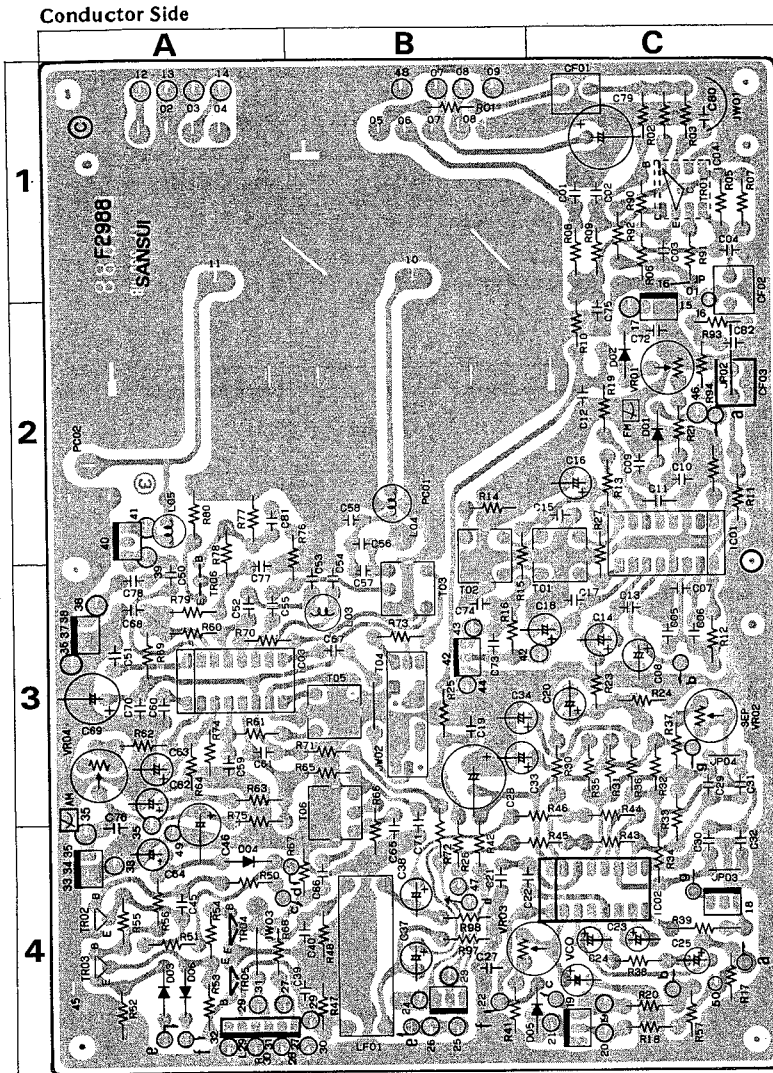

Parts List

Part No.	Stock No.	Description	Position
•Transistor			
TR01	0306341, 2	2SC1674 L, K	1C
TR02	0306740, 1	2SC1845 F, E	4A
TR03	0301090, 1	2SA992 F, E	4A
TR04, 05	0306581, 2	2SC1634 (6, 7)	4A
•IC			
IC 01	0360750	MPC1167C	2C
IC 03	0360800	LA1240	3A
IC 07	0360990	UPC1161C	
•Diode			
D 01 ~ 05	0311160	1S2473D	2C, 4A, 4C
•Varistor			
D 02	0340150	MV12	2C
C 21	0622471	470pF 125V P.C.	4B
C 23	0673228	0.22µF 35WV E.C.	4C
C 24	0573159	1.5µF 35WV E.C.	4C
C 25	0573339	3.3µF 35WV E.C.	4C
C 26	0622471	470pF 125V P.C.	4C
C 31, 32	0622561	580pF 125V P.C.	3C, 4C
C 56	0622391	390pF 125V P.C.	2B
C 57	0669210	10pF 50V C.C.	3B
C 58	0669408	22pF 50V C.C.	2B
R 39	0210681	680Ω 1/2W N.I.R.	4C
L 01	4290300	18µH Inductor	3B
L 03	4900110	100µH Inductor	2B, 2A
L 04, 05	4900140	1µH Inductor	
T 01	4236050	10.7 MHz quadrature coil	2, 3C
T 02	4238060	10.7 MHz quadrature coil	2, 3B
T 03	4220710	AM OSC Coil	3B
T 04	4220730	AM OSC Coil	3B
T 05	0910490	450 kHz Filter	3B
T 06	4230620	450 kHz IF Coil	3B
T 06	0910450	Filter Coil	3B
CF 01, 02	0910480	AM OSC Coil	1C
LF 01	0910220	Low Pass Filter	4B
VR01	1035170	Volume, 47kΩ (B), FM Signal Meter Adj.	2C
VR02	1035210	Volume, 220kΩ (B), FM Stereo Separation Adj.	3C
VR03	1034250	Volume, 4.7kΩ (B), V.C.O. Free Run Adj.	4B
VR04	1035110	Volume, 4.7kΩ (B), AM Signal Meter Adj.	3A

3-2. F-3015 Equalizer Amp Circuit Board (Stock No. 7551471 - TA-300) (Stock No. 7551511 - TA-500)

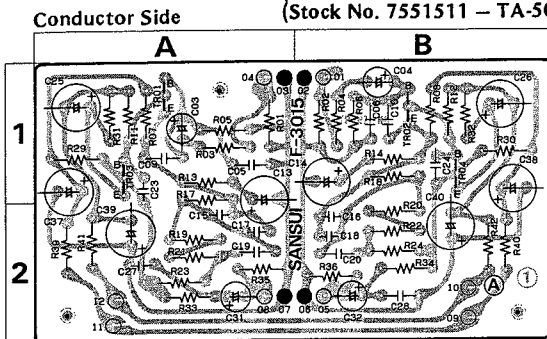

Parts List

Parts No.	Stock No.	Description	Position
•Transistor			
TR01, 02	0300900, 1	2SA906 (G, H)	1A, 1B
TR03, 04	0306740, 1	2SC1845 F, E	1A, 1B
C 15, 16	0680013	0.0033µF 100V C.	2A, 2B
C 17, 18	0622121	120pF 125V P.C.	2A, 2B
C 19, 20	0680027	100V 0.012µF M.C.	2A, 2B
R 39, 40	0191560	56Ω 1/4W F.R.	2A, 2B
R 41, 42	0191560	56Ω 1/4W F.R.	2A, 2B

3-3. F-2987 Power Supply Circuit Board (Stock No. 7503281 - TA-300) (Stock No. 7503311 - TA-500)

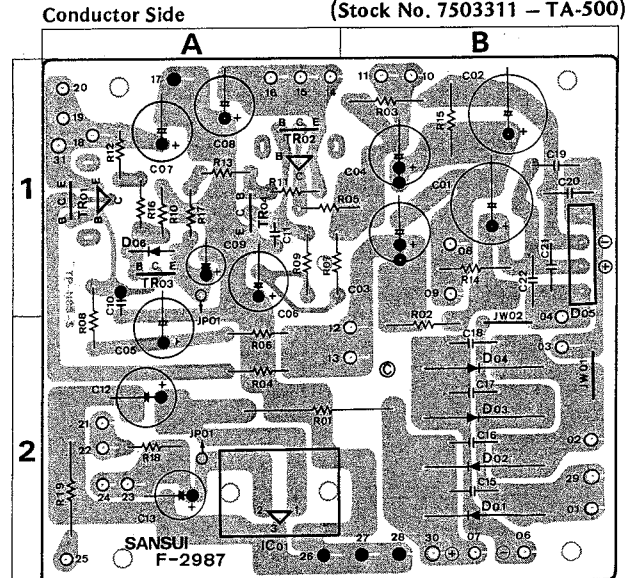

3-4. F-3016 Tone Control & Power Amp Board (Stock No. 7572201 – TA-300) (Stock No. 7572241 – TA-500)

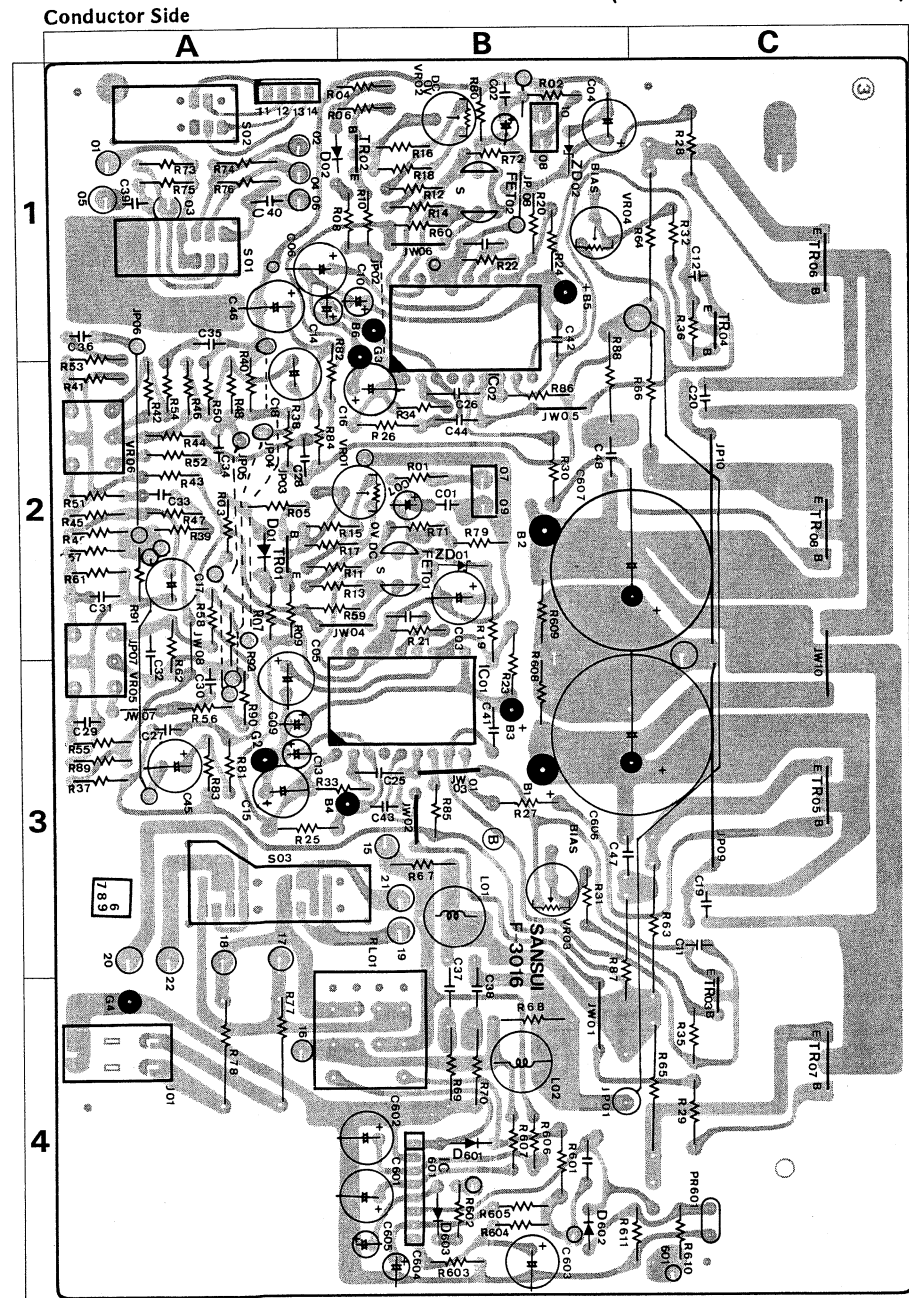

Parts No.	Stock No.	Description	Position
Parts List			
•Transistor			
TR03,04	0306740, 1	2SC1845 F, E	4C.1C
•IC			
IC 01, 02	0360940	AN7070	3B.1B
C 19, 20	0682011	0.01 μ F 100V M.C.	3C.2C
C 29, 30	0680035	0.027 μ F 100V M.C.	3A
C 31, 32	0680057	0.22 μ F 100V M.C.	2A
C 33, 34	0680009	0.0022 μ F 100V M.C.	2A
C 35, 36	0680033	0.022 μ F 100V M.C.	1A
C 39, 40	0680025	0.01 μ F 100V M.C.	1A
R 23, 24	0210100	10 Ω 1/2W N.I.R.	3B.1B
R 25, 26	0210100	10 Ω 1/2W N.I.R.	3A.2B
R 27, 28	0191479	4.7 Ω 1/4W F.R.	3B.1C
R 29, 30	0191479	4.7 Ω 1/4W F.R.	4C.2B
R 67, 68	0210229	2.2 Ω 1/2W N.I.R.	3B.4B
R 85, 86	0191479	4.7 Ω 1/4W F.R.	3B.2B
R 608	0211472	4.7k Ω 1W N.I.R.	3B
R 609	0211472	4.7k Ω 1W N.I.R.	2B
L 01, 02	4290370	1 μ H Filter Coil	3B.4B
VR03, 04	1035050	470 Ω (B) Bias Volume	3B.1B
VR05, 06	1015360, 1	100k Ω x 2, Bass & Treble Volume	3A.2A
S 01	1171780	Lever Switch, FM Muting	1A
S 02	1171780	Lever Switch, High Filter	1A
S 03	1190650	Rotary Switch, Speakers	3A
<TA-300>			
•Transistor			
TR05, 06	0301210, 1	2SA1135 (O, Y)	3C.1C
TR07, 08	0306900, 1	2SC2665 (O, Y)	4C.2C
C 606	0549117	4700 μ F 50V E.C.	3B, C
C 607	0549117	4700 μ F 50V E.C.	2B, C
R 63, 64	0212338	0.33 Ω 2W N.I.R.	3C.1C
R 65, 66	0212338	0.33 Ω 2W N.I.R.	4C.2B
R 69, 70	0211100	10 Ω 1W N.I.R.	4B
R 77, 78	0212221	220 Ω 2W N.I.R.	4A
R 87, 88	0211100	10 Ω 1W N.I.R.	3B.2B
<TA-500>			
•Transistor			
TR01, 02	0306680, 1	2SC2071 B, V	2A.1B
TR05, 06	0306920, 1	2SC2578 O, Y	3C.1C
TR07, 08	0301230, 1	2SA1103 O, Y	4C.2C
•IC			
IC 601	0360900	HA12002	4B
•FET			
FET01, 02	0370311, 2	2SK129 L, M	2B.1B
•Diode			
D 01, 02	0311160	1S2473D	2A.1A
D 602	0311160	1S2473D	4B
•Zener Diode			
ZD01, 02	0316240	RD9.1E	2B.1B
ZD601	0316510	RD24E	2B.1B
C 606	0549118	6800 μ F 50V E.C.	3B, C
C 607	0549118	6800 μ F 50V E.C.	2B, C
R 19, 20	0211272	2.7k Ω 1W N.I.R.	2B.1B
R 37, 38	0280302	3k Ω 1/3W N.I.R.	3A.2A
R 63, 64	0213338	0.33 Ω 3W N.I.R.	3C.1C
R 65, 66	0213338	0.33 Ω 3W N.I.R.	4C.2C
R 69, 70	0212100	10 Ω 2W N.I.R.	4B
R 77, 78	0213221	220 Ω 3W N.I.R.	4A
R 87, 88	0212100	10 Ω 2W N.I.R.	3B.2B
R 601	0212561	560 Ω 2W N.I.R.	4B
RL01	1150400	Relay	4B
	1150480	Relay	
	1150490	Relay	
VR01, 02	1035070	1k Ω DC 0V Adj. Volume	2B.1B

Parts No.	Stock No.	Description	Position	Parts No.	Stock No.	Description	Position
Parts List							
•Transistor				•Diode			
TR03	0306740, 1	2SC1845 F, E	1A	D 01 - 04	0311530	3002	2B
TR04	0301090, 1	2SA992 F, E	1A	R 01	0135121	120 Ω 5W Ce.R.	2A
•IC				R 02	0192100	10 Ω 1/2W F.R.	1B
IC 01	0361010	FS7815M	2A	R 03	0192100	10 Ω 1/2W F.R.	1B
•Diode				R 06	0210103	10k Ω 1/2W N.I.R.	2A
D 05	0311700	RB-152	1B	R 07	0210103	10k Ω 1/2W N.I.R.	1A
D 06	0311160	1S2473D	1A	<TA-500>			
C 15 ~ 22	0655103	10000pF 500V C.C.	1, 2B	•Transistor			
R 08	0210222	2.2k Ω 1/2W N.I.R.	2A	TR01	0308391, 2	2SD313 AL D, E	1A
R 09	0210222	2.2k Ω 1/2W N.I.R.	1A	TR02	0303231, 2	2SB507 D, E	1A
R 14	0211472	4.7k Ω 1W N.I.R.	1B	•Diode			
R 15	0211472	4.7k Ω 1W N.I.R.	1B	D 01 - 04	0311570	ERD03-02H	2B
R 18	0191479	4.7 Ω 1/4W F.R.	2A	R 01	0135151	150 Ω 5W Ce.R.	2A
R 19	0212391	390 Ω 2W N.I.R.	2A	R 04	0191479	4.7 Ω 1/4W F.R.	2A
<TA-300>							
•Transistor				R 06	0210222	2.2k Ω 1/2W N.I.R.	2A
TR01	0306740, 1	2SC1845 F, E	1A	R 07	0210222	2.2k Ω 1/2W N.I.R.	1A
TR02	0301090, 1	2SA992 F, E	1A				

• The circuit boards, F-2986, F-2983, F-2985, F-2984 & F-3017 are not supplied as the assembled, the individual parts on the circuit boards, however are provided for orders.

3-5. F-2986 Fuse Circuit Board

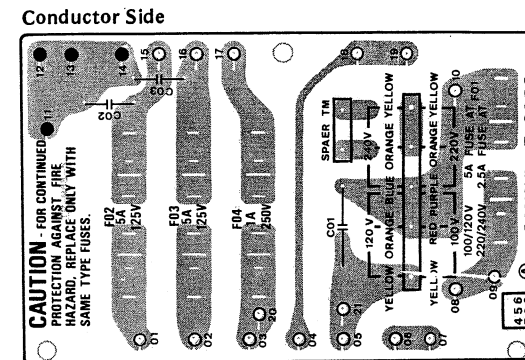

Parts No.	Stock No.	Description
Parts List		
C 01	0659802	0.0047 μ F 150V
C 02	0655103	10000pF 500V C.C.
C 03	0655103	10000pF 500V C.C.
F 01	0431250	AC Fuse 2.5A 250V
F 02, 03	0433280	Quick Acting Fuse 5A 250V

3-6. F-2983 Selector Circuit Board

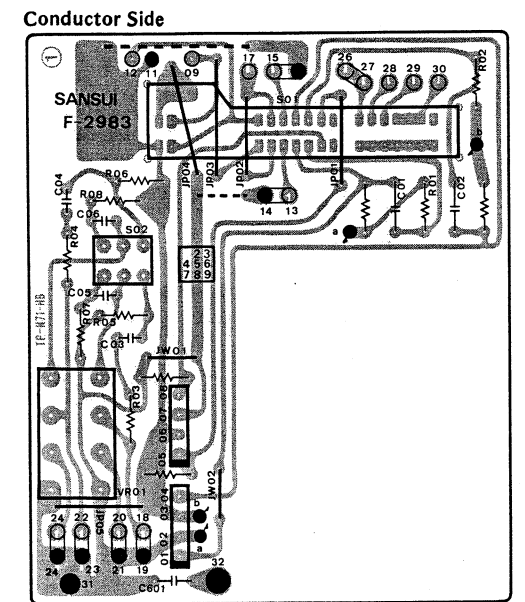

Parts No.	Stock No.	Description
Parts List		
C 01, 02	0680057	0.22 μ F 100V M.C.
C 03, 04	0622511	510pF 125V P.C.
VR01	1020330, 1	150k Ω x 2 Volume
S 01	1190660	Rotary Switch, selector
S 02	1131550	Push Switch, loudness
<TA-500>		
R 901	0200561	560 Ω 1/2W N.I.R.

3-7. F-2985 Tape Monitor Switch Circuit Board <TA-500>

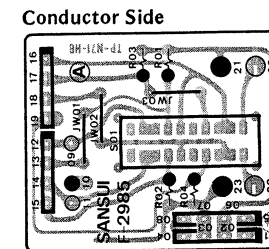

Parts No.	Stock No.	Description
Parts List		
S 01	1171880	Lever Switch, tape monitor

3-8. F-2984 Tape Monitor Switch Circuit Board <TA-300>

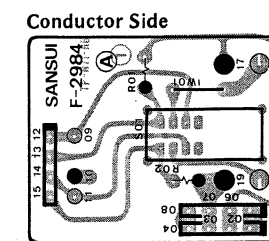

Parts No.	Stock No.	Description
Parts List		
S 01	1171780	Lever Switch, tape monitor

3-9. F-3017 FM Stereo Indicator Circuit Board

Parts No.	Stock No.	Description
Parts List		
LED01	0319060	LED

Abbreviations

C.R.	Carbon Resistor
S.R.	Solid Resistor
Ca.R.	Cement Resistor
M.R.	Metal Film Resistor
F.R.	Fusing Resistor
N.I.R.	Non-Inflammable Resistor
M.C.	Mylar Capacitor
E.C.	Electrolytic Capacitor
BP.E.C.	Bi-Polar Electrolytic Capacitor
C.C.	Ceramic Capacitor
Mi.C.	Mica Capacitor
O.C.	Oil Capacitor
P.C.	Polystyrene Capacitor
T.C.	Tantalum Capacitor

4. OTHER PARTS

4-1. Front View

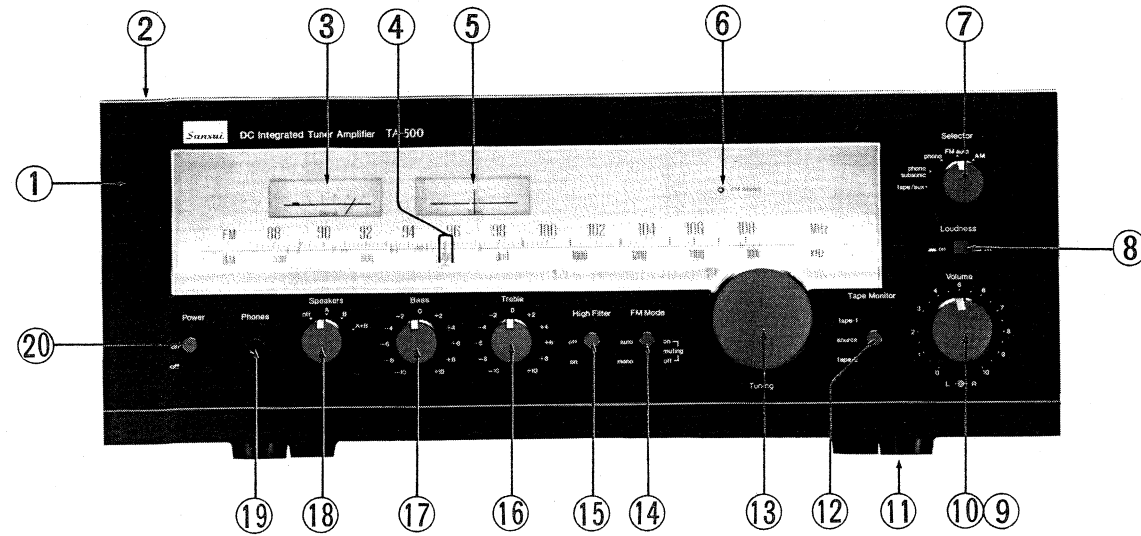

4-2. Top View

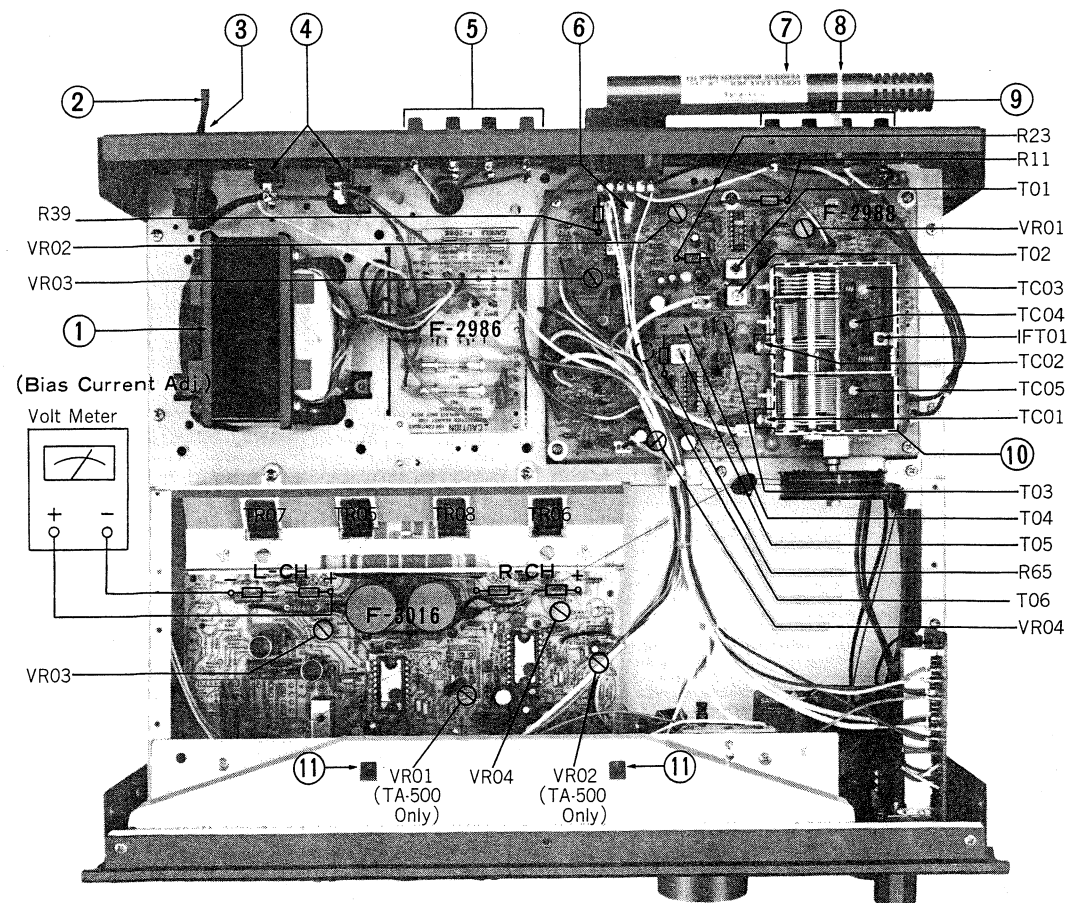

4-3. Bottom View

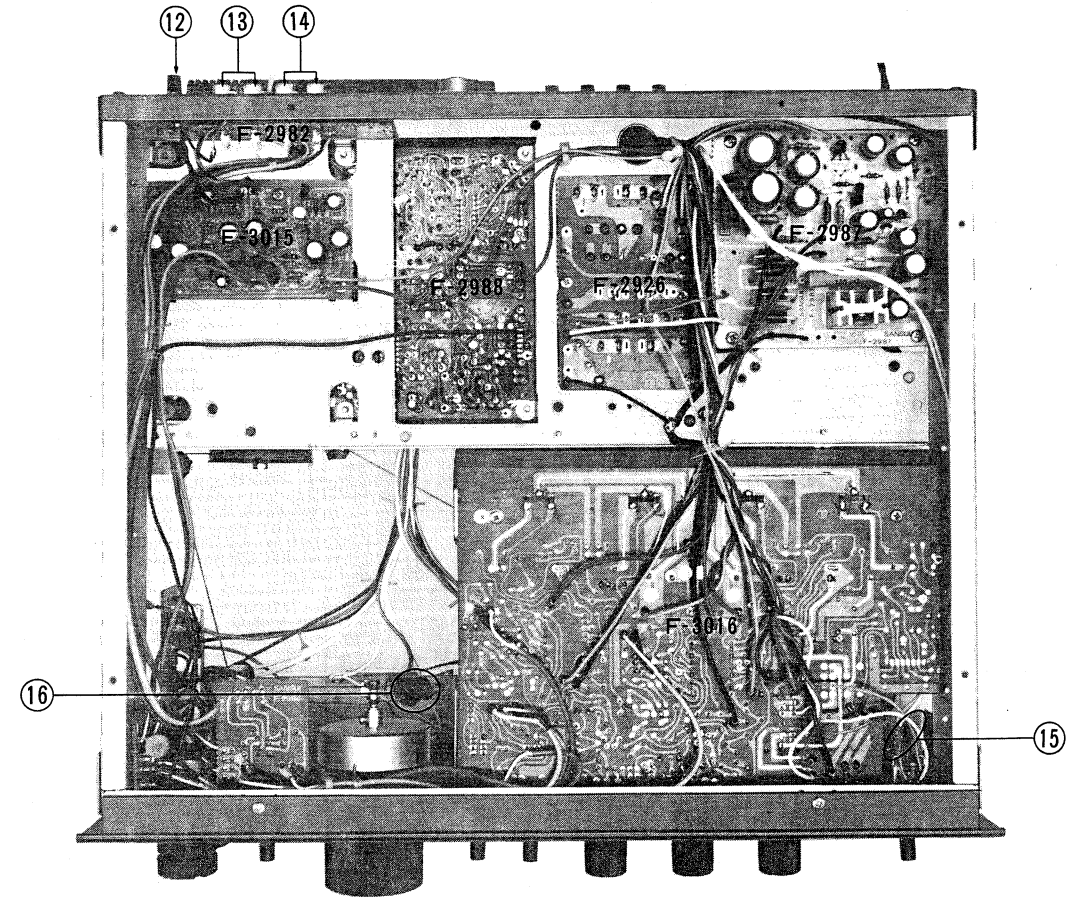

Parts List (Front View)

Parts No.	Stock No.	Description
1	7008400	Front Panel Ass'y <TA-300>
	7008190	Front Panel Ass'y <TA-500>
2	5456640	Front Glass
	5059060	Masking Plate for Knob
	5059070	Masking Plate for Knob
	5059080	Masking Plate for Knob
	5006870	Bonnet <TA-300>
3	5006900	Bonnet <TA-500>
	4301290	Signal Meter
4	5416463	Dial Pointer
5	4301300	Tune Meter
6	0319060	Stereo Indicator
7	5318930	Knob, selector
	1190660	Rotary Switch, selector
8	5326620	Knob, loudness
	1131550	Push Switch, loudness
9	5310270	Knob, volume (R-ch)
	5310280	Knob, volume (L-ch)
10	1011190, 1	Master Volume
	5507350	Leg
11	5326612	Knob, tape monitor
12	1171780	Tape Monitor Switch <TA-300>
	1171880	Tape Monitor Switch <TA-500>
13	5318960	Knob, tuning
	7036631	Tuning Unit
14	5326612	Knob, FM mode
	1171780	FM Mode Switch
15	5326612	Knob, high filter
	1171780	High Filter Switch
16	5318930	Knob, treble
	1015360, 1	Treble Volume
17	5318930	Knob, bass
	1015360, 1	Bass Volume
18	5318930	Knob, speaker selector
	1190650	Rotary Switch, speaker selector
19	2430550	Headphone Jack
20	5326612	Knob, power switch
	1172030	Power Switch <TA-300>
	1172000	Power Switch <TA-500>

Parts List (Top & Bottom View)

Parts No.	Stock No.	Description
1	4002990	Power Transformer <TA-300>
	4003030	Power Transformer <TA-500>
2	3800470	Power Cord
3	3910600	Strain Relief
4	2450070	AC Outlet
5	2210410	Speaker Terminal
6	0620682	6800pF 50V P.C.
7	4200970	AM Loopstick Antenna
8	3910780	Antenna Holder
9	2210420	Antenna Terminal
10	7510751	FM Front End Pack
11	0400710	Lamp with lead wire
12	2230150	Ground Terminal
13	2200620	Input Terminal (PHONO, TAPE/AUX)
14	2200580	Input Terminal (REC, PLAY)
15	0659801	0.01μF 150V C.C.
16	7136150	Tension Unit

Design and specifications subject to change without notice for improvement. La présentation et les spécifications sont susceptibles d'être modifiées sans préavis par suites d'améliorations éventuelles. Änderungen, die dem technischen Fortschritt dienen, bleiben vorbehalten.

5. SCHEMATIC DIAGRAM 5-1. TA-300

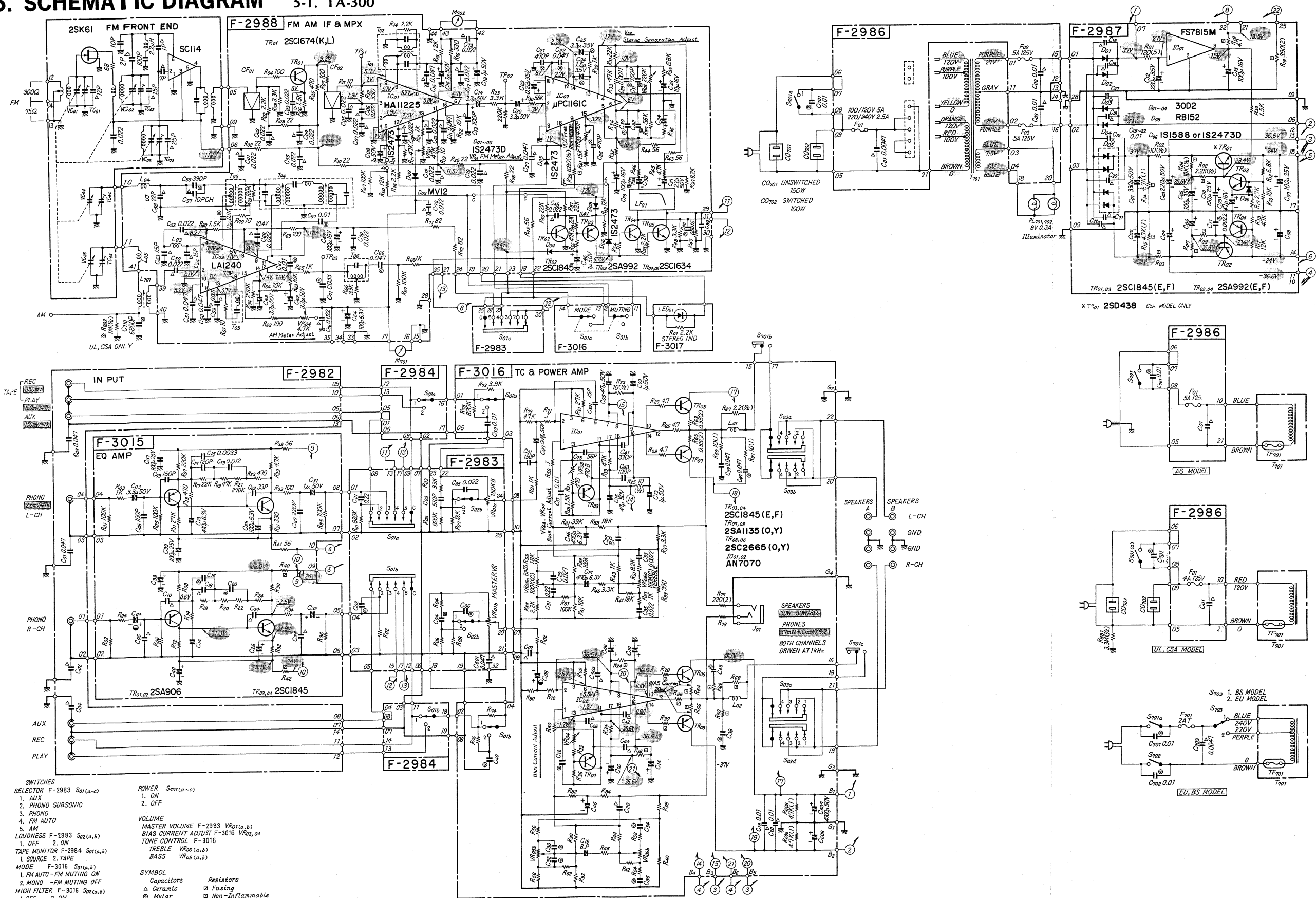

- SWITCHES SELECTOR F-2983 S01(a-c) 1. AUX 2. PHONO SUBSONIC 3. PHONO 4. FM AUTO 5. AM LOUDNESS F-2983 S02(a,b) 1. OFF 2. ON TAPE MONITOR F-2984 S01(a,b) 1. SOURCE 2. TAPE MODE F-3016 S01(a,b) 1. FM AUTO - FM MUTING ON 2. MONO - FM MUTING OFF HIGH FILTER F-3016 S02(a,b) 1. OFF 2. ON SPEAKER F-3016 S03(a-d) 1. OFF 2. A 3. B 4. A+B POWER S01(a-c) 1. ON 2. OFF VOLUME MASTER VOLUME F-2983 VR01(a,b) BIAS CURRENT ADJUST F-3016 VR03,04 TONE CONTROL F-3016 TREBLE VR06(a,b) BASS VR05(a,b) SYMBOL Capacitors Resistors Ceramic Fusing Nylon Non-Inflammable Styrol

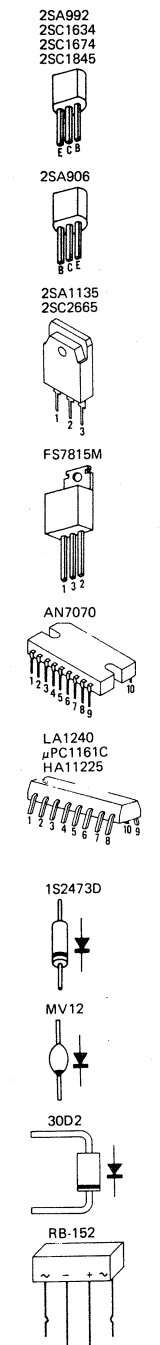

1 2 3 4 5 8

• Design and specifications subject to change without notice for improvement.
 • La présentation et les spécifications sont susceptibles d'être modifiées sans préavis par suites d'améliorations éventuelles.
 • Änderungen, die dem technischen Fortschritt dienen, bleiben vorbehalten.

5-2. TA-500

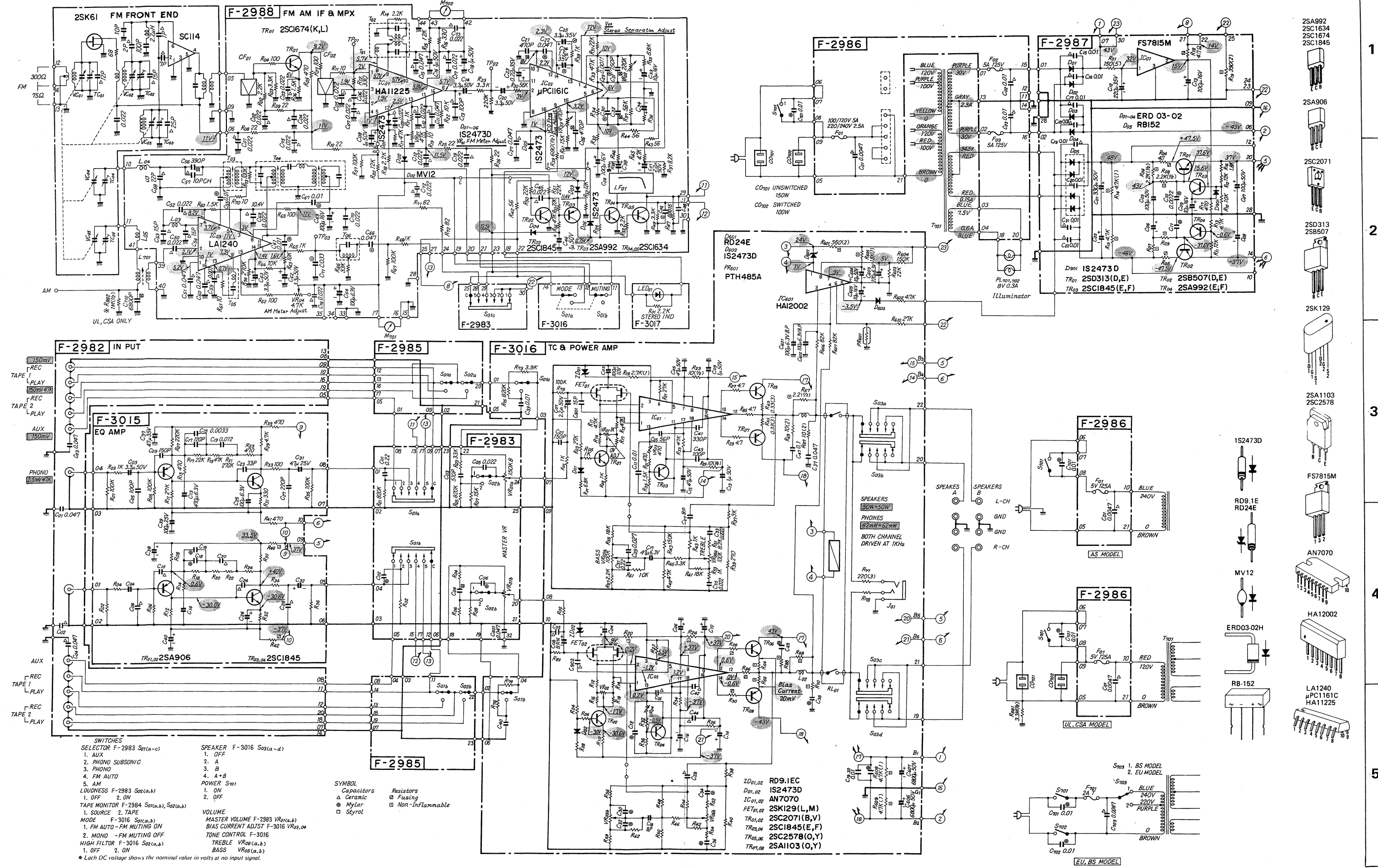

- 1 2SA992
2SC1634
2SC1845
- 2 2SA906
2SC2071
2SD313
2SB507
- 3 2SA1103
2SC2578
- 4 AN7070
HAI12002
LA1240
μPC1161C
HAI1225
- 5 RD9.1E
RD24E
MV12
ERD03-02H
RB-152

6. THREADING OF DIAL CORD

- If a dial cord is cut off or slips, replace it by following procedures.
As this unit uses 0.5 mmφ cord, please replace it with the same type certainly.
- The length of dial cord is approximately 170 cm (66.9 inch).

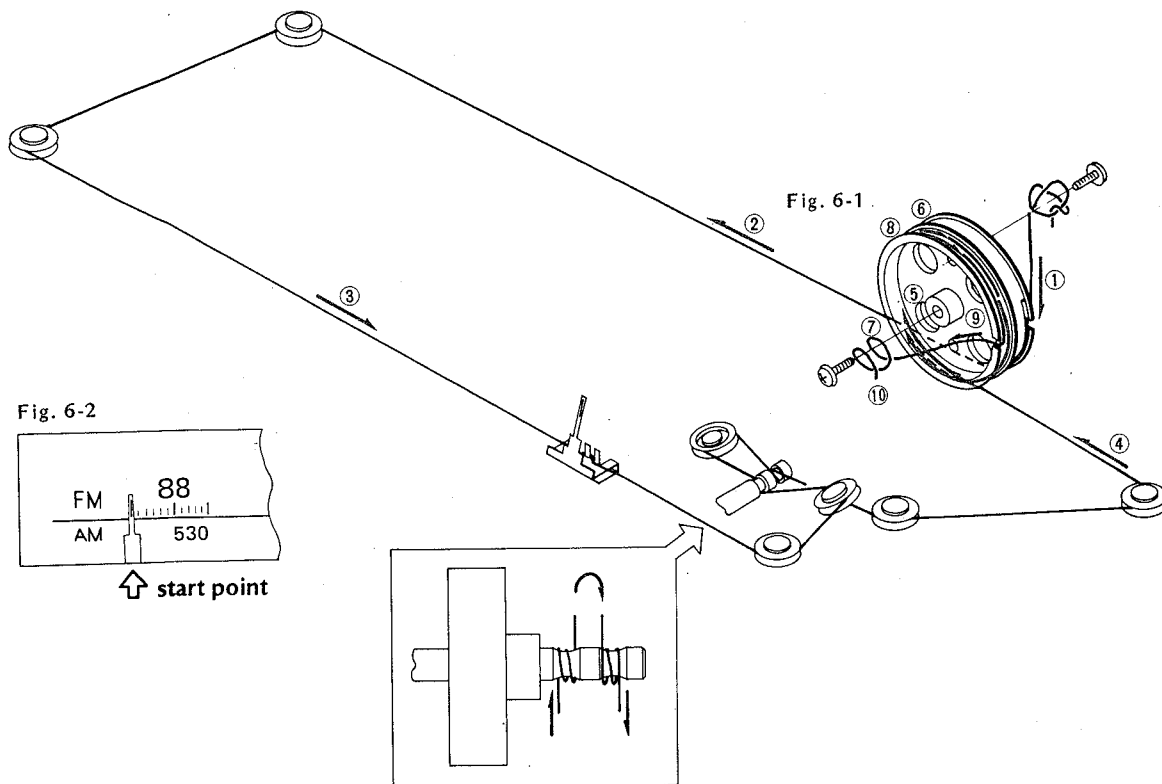

6-1. Threading of Dial Cord

Thread the dial cord in numerical order from 1 to 10 as Fig. 6-1.

- Open the variable capacitor completely.

Stock No.	Description
6036051	Dial Cord (0.5 mmφ)
6146721	Dial Pulley

6-2. Attachment of Dial Pointer

Set the dial pointer to the start-point as Fig. 6-2:

- Confirm that the dial pointer runs smoothly on the dial scale by turning the tuning shaft.

7. PACKING LIST

Parts No.	Stock No.	Description
1	9116790	Vinyl Cover
2	9028320	Styrofoam Packing (ea.)
3	{ 9001660	Carton Case <TA-300>
	{ 9001691	Carton Case <TA-500>
4	5996080	Curl Stopper

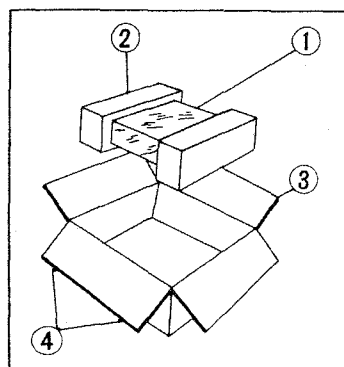

8. ACCESSORY PARTS LIST

Stock No.	Description
9204480	Operating Instructions <TA-300>
9204470	Operating Instructions <TA-500>
9238060	Schematic Diagram <TA-300>
9238090	Schematic Diagram <TA-500>
5396720	Rack Mounting Adaptor (ea.)
3820100	FM Antenna

MEMO



SANSUI ELECTRONICS CORPORATION: 1250 Valley Brook Ave. Lyndhurst, N.J. 07071 U.S.A.
 333 West Alondra Blvd. Gardena, California 90247 U.S.A.
 3036 Koapaka St. Honolulu, Hawaii 96819 U.S.A.

SANSUI AUDIO EUROPE N.V.: North Trade Bldg (9th floor) Noorderlaan 133-Bus 1, 2030 Antwerp, Belgium
 SNASUI AUDIO EUROPE S.A.: Arabella center, 6 Frankfurt AM Main, Lyoner Strasse 44-48, West Germany

SANSUI ELECTRIC COMPANY LTD.: 14-1, Izumi 2-chome, Suginamiku, Tokyo 168 Japan PHONE: (03) 323-1111/TELEX: 232-2076