

# SERVICE MANUAL

SERVO ROCKED TUNER

## SANSUI TU-519



### SPECIFICATIONS

#### FM Section

Tuning range . . . . . 88 to 108 MHz

#### Usable Sensitivity

Mono IHF . . . . . 9.8 dBf (1.7  $\mu$ V; T100)

DIN . . . . . 1.0  $\mu$ V

Stereo IHF . . . . . 16.5 dBf

#### 50 dB Quieting Sensitivity

Mono . . . . . 13.5 dBf

Stereo . . . . . 36.0 dBf

#### Signal to noise ratio at 65 dBf

Mono . . . . . 81 dB

Stereo . . . . . 76 dB

#### Distortion (at 65 dBf)

Mono . . . . . less than 0.1 % at 100 Hz

less than 0.08 % at 1,000 Hz

less than 0.1 % at 6,000 Hz

Stereo . . . . . less than 0.1 % at 100 Hz

less than 0.08 % at 1,000 Hz

less than 0.1 % at 6,000 Hz

#### Alternate channel selectivity (at 400 kHz)

. . . . . 60 dB

#### Capture ratio . . . . . 1.0 dB

#### Image response ratio . . . . . 80 dB (at 98 MHz)

#### Spurious response ratio

. . . . . 88 dB (at 98 MHz)

#### Stereo separation . . . . . 35 dB at 100 Hz

45 dB at 1,000 Hz

35 dB at 10,000 Hz

#### Frequency response . . . . . 30 to 15,000 Hz

+0.2 dB -0.5 dB

#### Antenna input impedance

. . . . . 300 ohms balanced

75 ohms unbalanced

#### AM Section

Tuning range . . . . . 530 to 1,600 kHz

#### Usable sensitivity (Bar antenna)

. . . . . 47 dB/m (220  $\mu$ V/m)

#### Selectivity ( $\pm 10$ kHz) . . . . . 35 dB

#### Signal to noise ratio . . . . . 50 dB

#### Others

Output level . . . . . 0 to 0.775 V

Power requirements . . . . . 100, 120, 220, 240 V 50/60 Hz

For U.S.A. and Canada

. . . . . 120 V (60 Hz)

Power consumption . . . . . 15 W

#### Dimensions

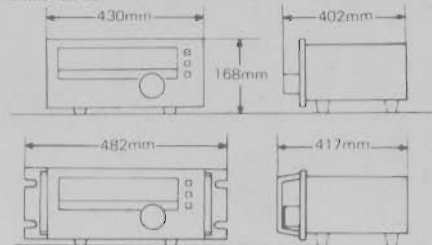

Weight . . . . . 7.8 kg (17.2 lbs) net

9.6 kg (21.1 lbs) packed

\* Design and specifications subject to change without notice for improvements.

\* In order to simplify the explanation illustrations may sometimes differ from the originals.

**Sansui**

SANSUI ELECTRIC CO., LTD.

# 1. BLOCK DIAGRAM

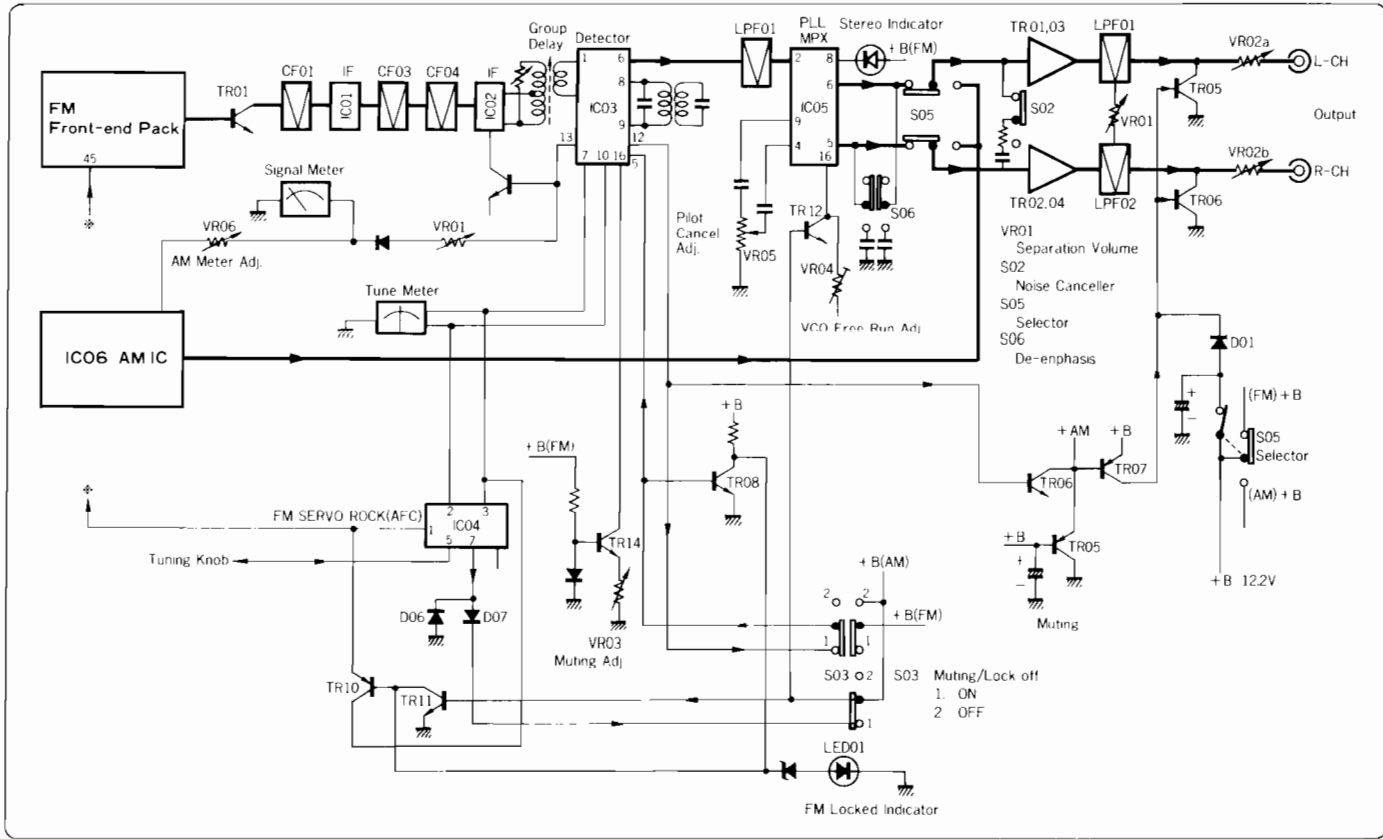

## ◇ IC05 HA-11223 <PLL MPX Circuit>

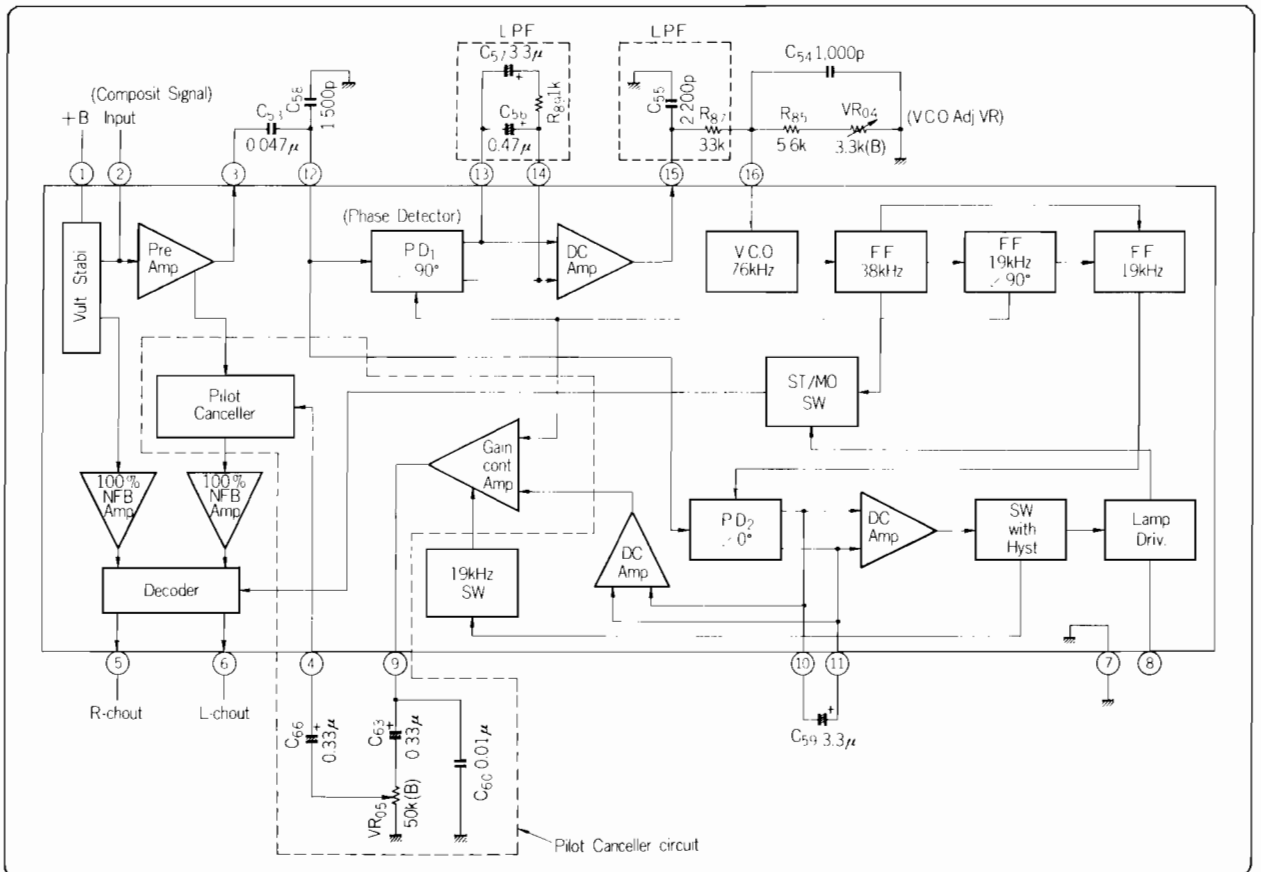

◇ IC03 HA-11225 <Quadrature Detector Circuit>

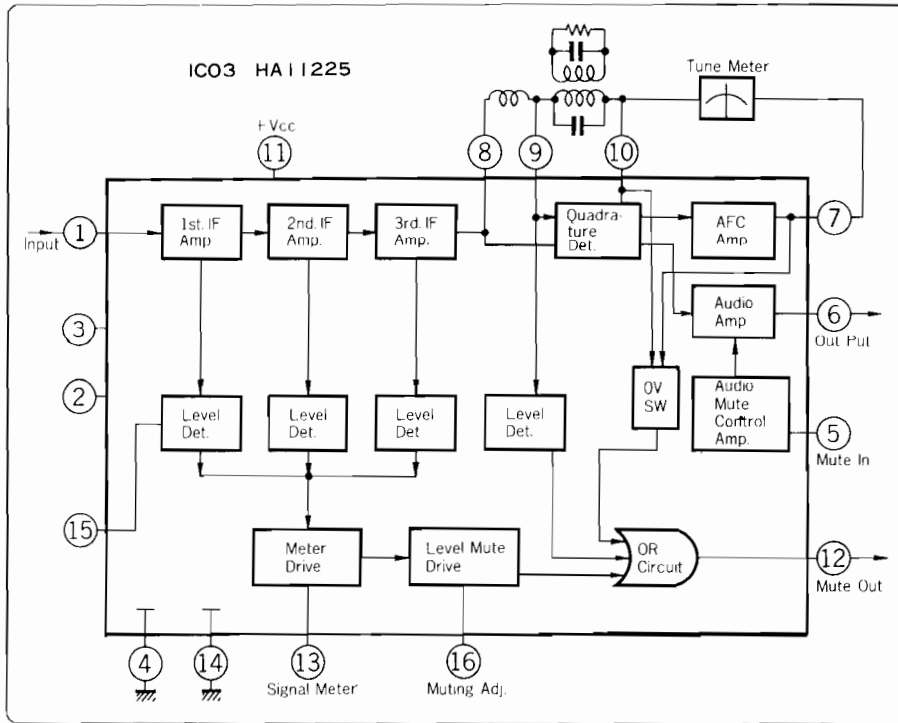

◇ IC04 NJM-4558 <Operation Amp>

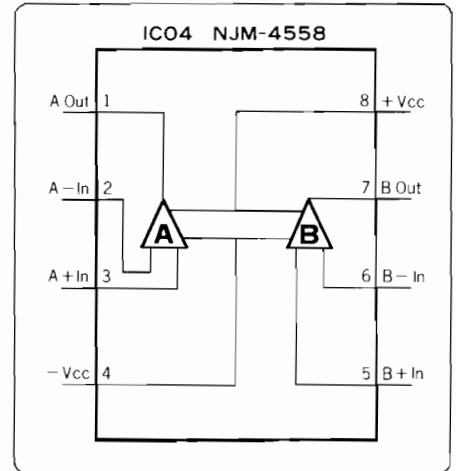

A, B: Operational Amp.

## 2. OPERATIONS

- Quadrature Detector Circuit
- PLL MPX Circuit
- FM Servo Lock Circuit
- FM Muting Circuit

2-1. The operation of Quadrature Detector Circuit and PLL MPX Circuit are explained on the service manual issued previously, therefore only the interior block diagrams of ICs are presented.

### 2-2. FM Servo Lock Circuit (See block diagram)

#### 1) Operation of FM servo lock (AFC)

The voltage of AFC output terminal, pin No. 7 and reference voltage of pin No. 10 of IC03 (quadrature IC) are the input signals of IC04 (operational IC).

From the output of IC04, proportional voltage to the tuning deviation (the center deviation of discriminator) is obtained. This output is fed to vari-cap at oscillator of front-end and controls oscillating frequency by varying the capacitance of vari-cap.

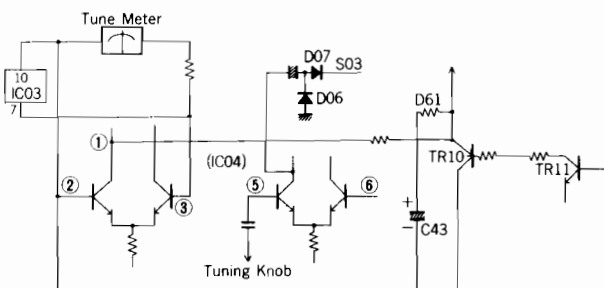

#### 2) Release of FG servo lock during tuning

The servo lock switch S03 being ON, the FG servo lock can be released during only tuning.

When tuning knob is touched by hand at tuning state, ham is generated because the knob is not grounded. This ham is amplified by IC04 then rectified by D06, 07 and turns TR10 & TR11 ON, which settle the voltage of pin No. 1 of IC04 to the reference voltage of 5.8 V that the servo lock is released.

#### 3) Operation of FM servo lock indicator

When receiving FM signal TR08 connected to muting output of IC03 is OFF that LED01 starts lighting. When turning OFF the FM servo lock, a voltage is supplied to the base of TR11 and turns TR11 ON that LED01 does not illuminate.

### 2-3. Muting Circuit

#### 1) By muting signal from pin No. 12 of IC03, TR06 & TR07 are actuated and short the audio outputs by TR05 & TR06 on F-2977.

On the other hand, the muting output of IC03 is fed-back to pin No. 5 of IC03 and actuates the internal muting circuit.

On this set, leakage signal after discriminator is completely eliminated by above mentioned the couple of mutings.

#### 2) The muting also functions when switching the power ON and selecting AM/FM (D01).

# 3. ADJUSTMENTS

## 1. FM Adjustment (See Top View on Page 6)

- Note:** 1. Selector . . . . . FM MONO  
 2. FM Muting Switch . . . . . OFF

3. Connection . . . . . Connect the output of genescope to TP through 100 pF ceramic capacitor.  
 4. Confirm start point of dial pointer before alignment.

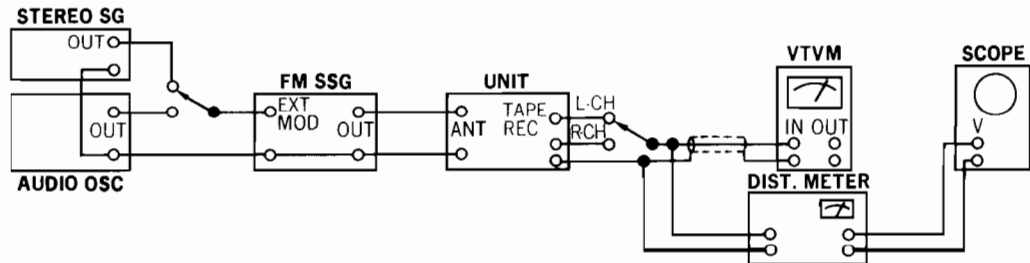
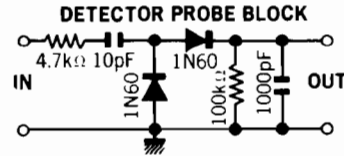
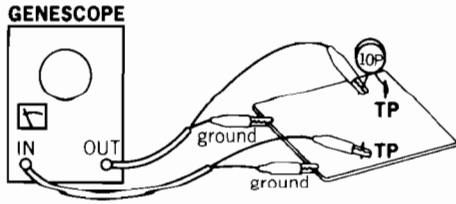

### (1) FM IF, RF Adjustment and Dial Calibration

STEP	SUBJECT	FEED SIGNAL		MEASURE OUTPUT	ADJUST	ADJUST FOR	CONDITION
		FROM	TO				
1.	IF Coil	Output 90 dB Genescope	TCa3 (Front-end)	Point B at R23 Use Detector Probe	IFT01 (Front-end)	Max. IF waveform	
			Point C at R27 F-2975	Point A at R35 Use Detector Probe	T01 F-2975		
2.	Discriminator Coil In case of using Genescope	Output 80 dB Genescope	TCa3 (Front-end)	Point E at R84	T03 F-2975 T02 F-2975	Steep linearity of S curve Make symmetrical S curve	
	Discriminator Coil In case of using Dist meter	98 MHz ANT Input 65 dBf (59.8 dB) 1000 Hz (100% MOD) FM SSG	ANT terminal 300Ω	OUT L or R-CH Dist Meter, VTVM & Scope	T01, T02, T03, VR02 VR07, VR08 F-2975 IFT01 (Front-end)	Min THD	
3.	Tune Meter	No ANT Input	Same as above	Tune Meter	T02 F-2975	Center on Meter	
4.	106 MHz Dial Calibration	106 MHz ANT Input 65 dBf (59.8 dB) 1000 Hz (100% MOD) FM SSG	ANT terminal 300Ω	OUT L or R-CH VTVM & Scope	TCa4 (Front-end)	Max. Output	
	90 MHz Dial Calibration	90 MHz ANT Input 65 dBf (59.8 dB) 1000 Hz (100% MOD) FM SSG	Same as above	Same as above		Confirm Max. Output	
5.	106 MHz RF Adj.	106 MHz ANT Input Minimum value with sine wave 1000 Hz (100% MOD) FM SSG	Same as above	Same as above	TCa1, TCa2, TCa3 (Front-end)		
	90 MHz RF Adj.	90 MHz ANT Input Minimum value with sine wave 1000 Hz (100% MOD) FM SSG	Same as above	Same as above		Confirm Max. Output	
6.	Signal Meter Volume	98 MHz ANT Input 65 dBf (59.8 dB) 1000 Hz (100% MOD) FM SSG	Same as above	Signal Meter	VR01 F-2975	4.3 on Meter	

(2) FM STEREO Adjustment

Note: Selector . . . . . FM AUTO

STEP	SUBJECT	FEED SIGNAL		MEASURE OUTPUT	ADJUST	ADJUST FOR	REMARKS
		FROM	TO				
1.	PLL VCO Adj.	98 MHz ANT Input 65 dBf (59.8 dB) FM SSG Pilot 19 kHz (9% MOD) R (or L) Mode 1 kHz + Pilot (100% MOD) STEREO SG	ANT terminal 300Ω	Stereo indicator	VR04 F-2975	Light indicator	Adjust the VR within center of lighting level.
	PLL VCO Adj. In case of using Freq.	98 MHz ANT Input 65 dBf (59.8 dB) FM SSG (No MOD)	Same as above	TP02 F-2975 Use Freq. counter	VR04 F-2975	76 kHz ± 150 Hz	
2.	PILOT cancel Adj.	98 MHz ANT Input 65 dBf (59.8 dB) FM SSG Pilot 19 kHz (9% MOD)	Same as above	OUT L-CH or R-CH VTVM & Scope	VR05 F-2975	Min. Output	Confirm Both Cancel
	PILOT cancel Adj. In case of Dist. meter	98 MHz ANT Input 65 dBf (59.8 dB) FM SSG Pilot 19 kHz (9% MOD) R-CH or L-CH MODE 1 kHz + Pilot (100% MOD)	Same as above	Same as above	VR05 F-2975	Min. Distortion	
3.	Separation	98 MHz ANT Input 65 dBf (59.8 dB) FM SSG Pilot 19 kHz (9% MOD) R Mode 1 kHz + Pilot (100% MOD) STEREO SG	Same as above	OUT L-CH VTVM & Scope	VR01 F-2977	OUT - 45 dB	Confirm separation L-CH → R-CH (-45 dB)
4.	Muting level	98 MHz ANT Input 15 dBf (9.8 dB) FM SSG Pilot 19 kHz (9% MOD) SUB 1 kHz + Pilot (100% MOD) STEREO SG	Same as above	Stereo indicator	VR03 F-2975	Muting level 15 dBf (9.8 dB) indicator turns ON.	FM MUTING Switch ON

2. AM IF Adjustment & Dial Calibration (See Top View on Page 6)

Note: 1. Selector . . . . . AM

2. Confirm start point of dial pointer before alignment.

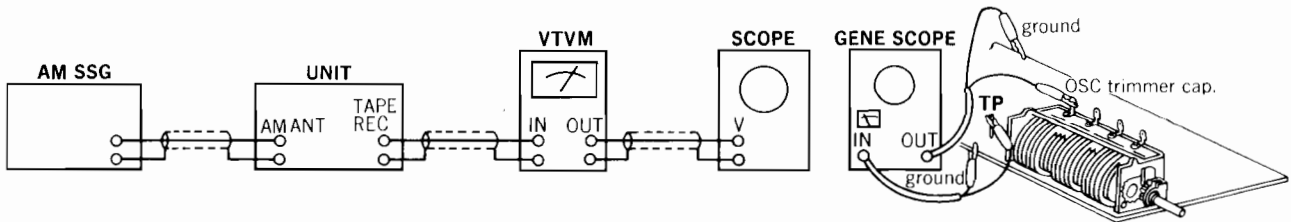

STEP	SUBJECT	FEED SIGNAL		MEASURE OUTPUT	ADJUST	ADJUST FOR	CONDITION
		FROM	TO				
1.	IF Coil	Genescope Output 70 dB	TC02 (Front-end)	Point D at R106 F-2975	T05, LC01 F-2975	Max. Output	
2.	600 kHz Dial Calibration	600 kHz ANT Input 60 dB 400 Hz (MOD 30%) AM SSG	AM ANT terminal	OUT L or R-CH VTVM & Scope	T04 F-2975	Max. Output	
	1400 kHz Dial Calibration	1400 kHz ANT Input 60 dB 400 Hz (MOD 30%) AM SSG	Same as above	Same as above	TC02 (Front-end)	Same as above	
3.	600 kHz RF Adj.	600 kHz ANT Input 50 dB 400 Hz (MOD 30%) AM SSG	Same as above	Same as above	Bar Antenna L702	Same as above	
	1400 kHz RF Adj.	1400 kHz ANT Input 50 dB 400 Hz (MOD 30%) AM SSG	Same as above	Same as above	TC01 (Front-end)	Same as above	
4.	Signal Meter volume	1000 kHz ANT Input 80 dB 400 Hz (MOD 30%) AM SSG	Same as above	Signal Meter	VR06 F-2975	4.3 on meter	
5.	9 kHz Knotch filter Adj.	9 kHz 5 mV OSC	Point D R106 F-2975	OUT L or R-CH VTVM & Scope	LC02 F-2975	Min. Output	

## ADJUSTMENTS

### ●NEW MEASUREMENT FOR FM.

Input signal level under the provision of IHFM-T-200, a new measurement method is indicated by available power ratio "dBf". To obtain approximate available power ratio "dBf", abstract 0.8 from attenuator indication of general FMSG (open load indication type); however, the former measurement, IHFM-T-100 is designated together too.

The way of modulation on IHFM-T-200 is shown below.

	modulation frequency	modulation mode	modulation factor
<b>FM MONO</b>	1000 Hz		100%
<b>FM STEREO</b>	1000 Hz	SUB	Pilot 9% Pilot + SUB 100%

- The relation between the standard input 65 dBf of IHFM-T-200 and the former indication "dB" is shown below.

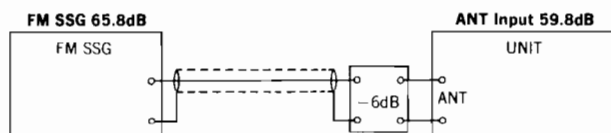

### ●Abbreviations

#### Equipment

AM FM Generator Oscilloscope . . . . .	Genescope
AM Standard Signal Generator . . . . .	AM SSG
FM Standard Signal Generator . . . . .	FM SSG
FM Stereo Generator . . . . .	Stereo SG
Oscilloscope . . . . .	Scope
Audio Oscillator . . . . .	Audio Osc.
Distortion Meter . . . . .	Dist. Meter

#### Others

Antenna . . . . .	ANT.
Modulation . . . . .	MOD.
Total Harmonic Distortion . . . . .	T.H.D.

## 4. OTHER PARTS

### Parts List <Front & Top View>

Parts No.	Stock No.	Description
1	5006880	Bonnet
2	7008261	Front Panel Ass'y
	5456640	Front Glass
	5305261	Frame, window
	5048221	Masking Sheet
	5507050	Front Glass Retainer Packing
	5336600	Sansui Mark
	5396690	Knob Ring
	5326620	Knob, AM, FM selector switch
	5286721	Knob Guide
	6906480	Knob Guide Spring
3	4301290	Signal Meter
4	4301300	Tune Meter
5	5408690	Dial Scale
6	0319060	Locked Indicator
7	0319050	FM Stereo Indicator
8	1172000	Power Switch
9	5326612	Knob, power switch
10	1171800	Muting Switch
11	5326612	Knob, muting switch
12	1171780	Noise Canceller Switch
13	5326612	Knob, noise canceller switch
14	5416463	Dial Pointer Ass'y
15	5318902	Tuning Knob
16	1131440	AM, FM Selector Switch
17	1015481	10kΩ B x 2, output level volume
18	5318850	Knob, output level
19	5507350	Leg
C 701	0659801	0.01μF 150V C.C.
C 702	0659802	0.0047μF 150V C.C.
C 706	0621682	6800pF 50V P.C.
L 702	4200960, 1	Bar Antenna
PT 701	4003010	Power Transformer
F 701	0432220	1A 250V AC Fuse
	2300060	Fuse Holder
	3800470, 1	AC Cord
	3910600	Strain Relief (AC Cord)
	2200300	2P Output Terminal
	3910490	Strain Relief (Antenna Cord)
	5286450	Bar Antenna Holder (A)
	5286480	Bar Antenna Holder (B)
	2210310	Antenna Terminal Board
	6146721	Pulley
	6400710	8V 300 mA Pilot Lamp
	7036680	Tuning Unit
	7136091	Tension Unit
	2410091	Voltage Selector, plug
	2410830	Voltage Selector, socket

4-1. Front View

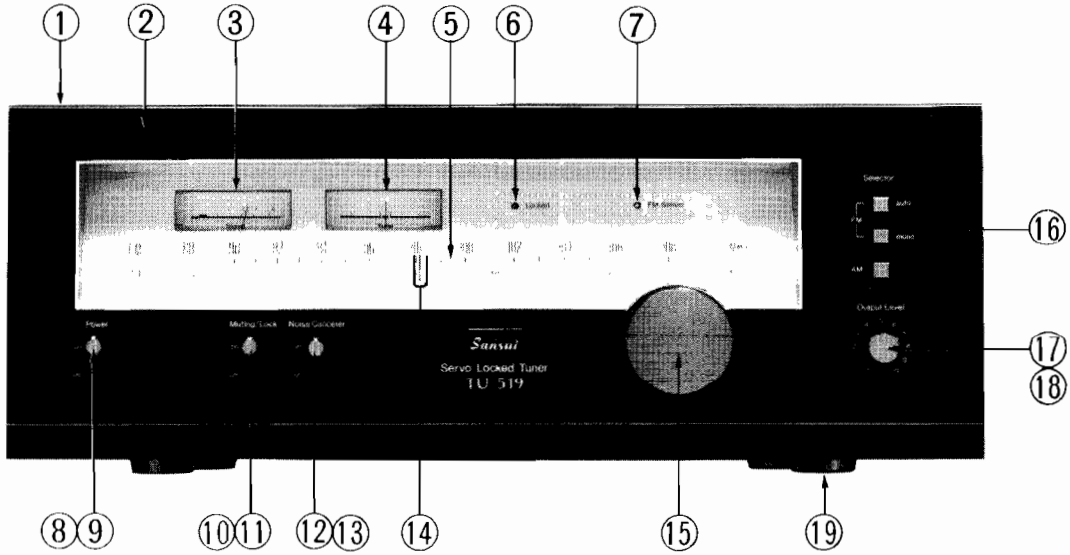

4-2. Top View

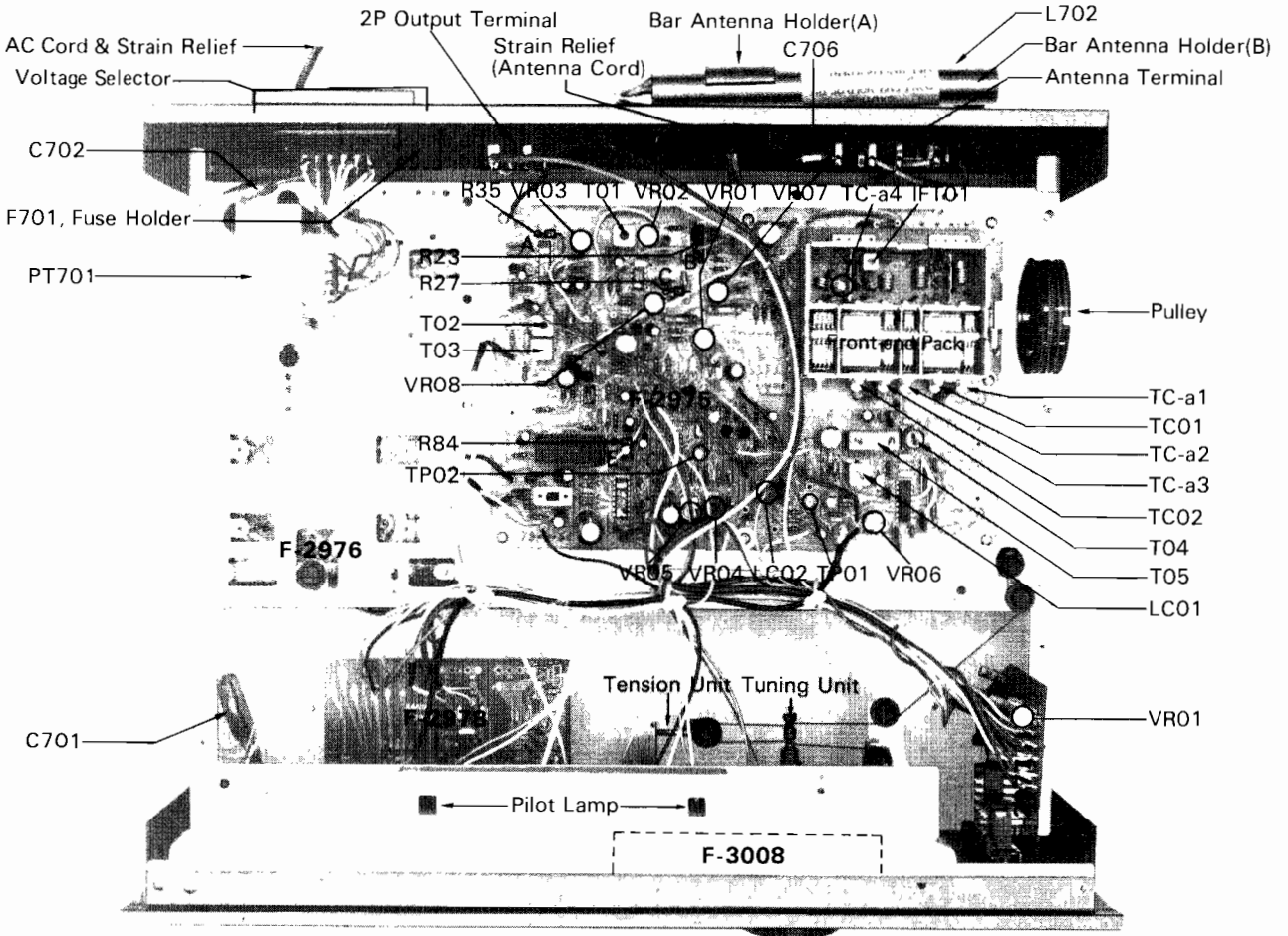

# 5. PARTS LOCATION & PARTS LIST

## 5-1. F-2975 Tuner Circuit Board (Stock No. 7522161)

Since some of capacitors and resistors are omitted from parts lists in this Service Manual, refer to the Common Parts List for capacitors & resistors which was appended previously to each Sansui Manual.

Conductor Side

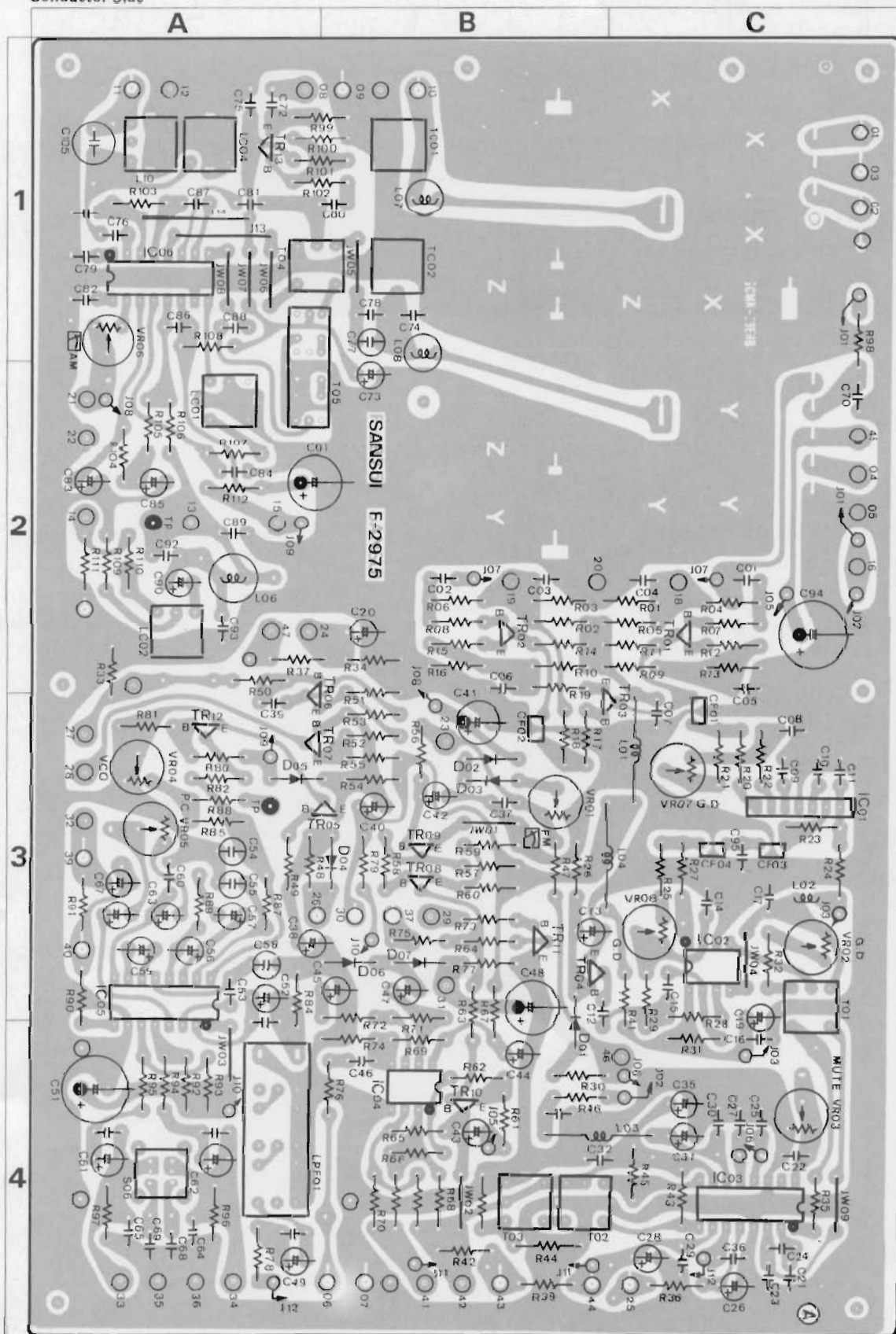



Parts List <F-2975>

Parts No.	Stock No.	Description	Position	Parts No.	Stock No.	Description	Position	Parts No.	Stock No.	Description	Position
<b>*Transistor</b>											
TR01	0306341, 2	2SC1674 L, K	2C	C 36	0622101	100pF 125V P.C.	4C	T 02	4236230	FM Detector Coil	4B
TR04	0306341, 2	2SC1674 L, K	3B	C 54	0622102	1000pF 125V P.C.	3A	T 03	4236240	FM Detector Coil	4B
TR05	0300510, 1	2SA733A P, Q	3B	C 55	0622222	2200pF 125V P.C.	3A	T 04	4220710	OSC Coil	1A
TR06	0305952, 3	2SC945 P, K	3A	C 56	0573478	0.47μF 35WV T.C.	3A	T 05	0910490	Filter 450 kHz	2A
TR07	0300510, 1	2SA733A P, Q	3A	C 57	0573339	3.3μF 35WV T.C.	3A	LC 01	4230620	IF Coil 455 kHz	2A
TR08	0305952, 3	2SC945 P, K	3B	C 58	0622152	1500pF 125V P.C.	3A	LC 02	0910450	Filter Coil	2A
TR10	0300510, 1	2SA733A (P), (Q)	4B	C 59	0573339	3.3μF 35WV T.C.	3A	LPF01	0910590	Channel Filter	4A
TR11	0305952, 3	2SC945 (P), (K)	3B	C 63	0573338	0.33μF 35WV T.C.	3A	CF 01	0910420	Ceramic Filter 10.7 MHz	3C
TR12	0305952, 3	2SC945 P, K	3A	C 66	0573338	0.33μF 35WV T.C.	3A	CF 03, 04	0910510	Ceramic Filter 10.7 MHz	3C
TR14	0305951	2SC945 Q	3A	C 74	0669406	22pF 50V C.C.	1B	VR01, 02	1035130	10kΩ B Group Delay Equalizer Adj. Volume	3B, 3C
<b>*IC</b>											
IC 01	0360590	TA7302P	3C	R 41	0191220	22kΩ 1/4W F.R.	3C	VR03	1035090	2.2kΩ B Muting Level Adj. Volume	4C
IC 02	0360510	LA-1222	3C	R 44	0231222	2.2kΩ 1/2W Me.R.	4B	VR04	1034240	3.3kΩ VCO Free run Adj. Volume	3A
IC 03	0360930	HA11225	4C	R 46	0191220	22kΩ 1/4W F.R.	4B	VR05	1037090	50kΩ B Pilot Cancel Adj. Volume	3A
IC 04	0360770	NJM4558D	4B	R 79	0191470	47kΩ 1/4W F.R.	3B	VR06	1037050	5kΩ B AM Signal Meter Adj.	1A
IC 05	0360680	HA11223	3A	R 98	0191220	22kΩ 1/4W F.R.	1C	VR07, 08	1036070	1kΩ B Group Delay Equalizer Adj. Volume	3C
IC 06	0360800	LA1240	1A	R 112	0191101	100Ω 1/4W F.R.	2A	S 06	1110270	De-Emphasis Switch	4A
<b>*Diode</b>											
D 01	0311160	1S2473D	4B	L 01	4290011	Peaking Coil 3.5μH	3C		7510790	Front End Pack	
D 02	0340120	VD1212	3B	L 02	4900100	Inductor 3.3μH	3C				
D 03-07	0311160	1S2473D	3A, B	L 03	4290011	Peaking Coil 3.5μH	4C				
D 08	0340150	MV-12		L 04	4290011	Peaking Coil 3.5μH	3C				
				L 06	4900400	100μH Inductor	2A				
				L 07, 08	4900140	1μH Inductor	1B				
ZD02	{ 0316390 0316400	RD6.2E B RD6.2E C		T 01	4235930	RF Coil 10.7 MHz	3C				

5-2. F-2977 Audio Amp Circuit Board (Stock No. 7597651)

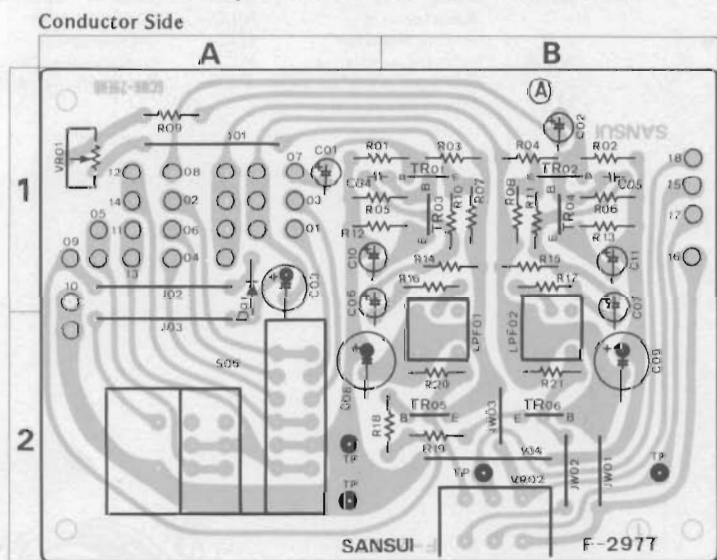

Parts List

Parts No.	Stock No.	Description	Position
<b>*Transistor</b>			
TR01, 02	0306740, 1	2SC1845 F, E	1B
TR03, 04	0301090, 1	2SA992 F, E	1B
TR05, 06	0305952, 3	2SC945 P, K	2B
<b>*Diode</b>			
D 01	0311160	1S2473D	
<b>*Zener Diode</b>			
ZD01	0316390	RD6.2E	
C 04, 05	0061150	15pF 125V C.C.	1A, 1B
LF 01, 02	0910520	Low Pass Filter	2B
VR01	1035410	47kΩ Stereo Separation Volume	1A
VR02	1015981	10kΩ Output Level Volume	2B
S 05	1131440	AM, FM Selector Switch	2A

5-3. F-2976 Power Supply Circuit Board (Stock No. 7503331)

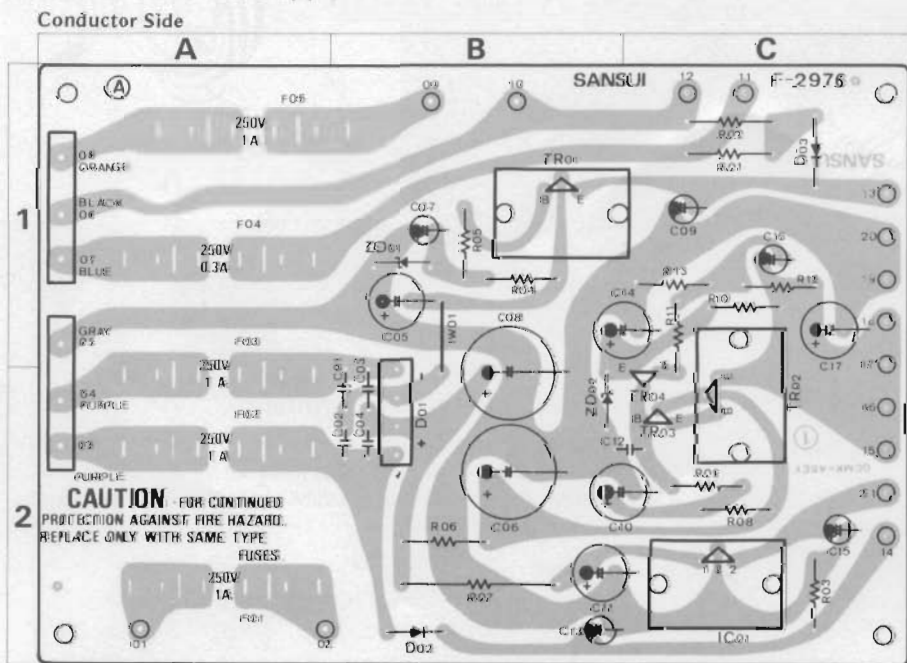

Parts List

Parts No.	Stock No.	Description	Position
<b>*Transistor</b>			
TR02	0308391 ~ 3	2SC313AL D, E, F	2C
TR03	0305951, 2	2SC945 Q, P	2C
TR04	0305951, 2	2SC945 Q, P	2C
<b>*Diode</b>			
D 01	0311700	RB 15Z	2B
D 02	0310340	10D1	2B
<b>*Zener Diode</b>			
ZD02	{ 0316390 0316400	RD6.2E B RD6.2E C	2B
R 06	0211100	10kΩ 1W N.I.F.	2B
F 02	0432210	0.5A 250V AC Fuse	2A
F 05	0432220	1A 250V AC Fuse	1A

Note: The circuit boards, F-3008, F-2978 are not supplied as the assembled, the individual parts on the circuit boards, however are provided for orders.

5-4. F-3008 LED Circuit Board

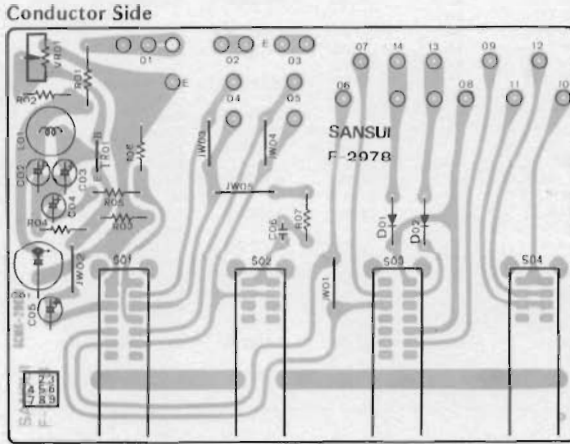

**Parts List**

Parts No.	Stock No.	Description
●Diode		
D 01, 02	0311100	1S2473D
S 02	1171780	Lever Switch, Noise Canceller
S 03	1171600	Lever Switch, Muting

5-5. F-2978 Muting Switch Circuit Board

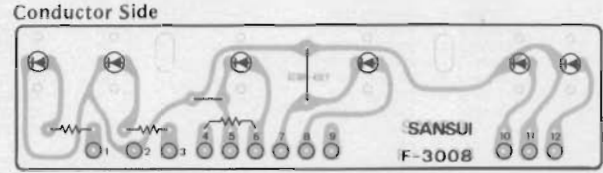

**Parts List**

Parts No.	Stock No.	Description
●LED		
LD01	0319050	FM Stereo (Red)
LD02	0319060	Quartz Locked (Green)

Abbreviations

C.R.	: Carbon Resistor	E.C.	: Electrolytic Capacitor
S.R.	: Solid Resistor	BP.E.C.	: Bi Polar Electrolytic Capacitor
Ca.R.	: Cement Resistor	C.C.	: Ceramic Capacitor
M.R.	: Metal Film Resistor	Mi.C.	: Mica Capacitor
F.R.	: Fusing Resistor	O.C.	: Oil Capacitor
N.I.R.	: Non Inflammable Resistor	P.C.	: Polystyrene Capacitor
M.C.	: Mylar Capacitor	T.C.	: Tantalum Capacitor

6. THREADING OF DIAL CORD

- If a dial cord is cut off or slips, replace it by following procedures. As this unit uses 0.5 mmφ cord, please replace it with the same type certainly.
- The length of dial cord is approximately 200 cm (78.7 inch).

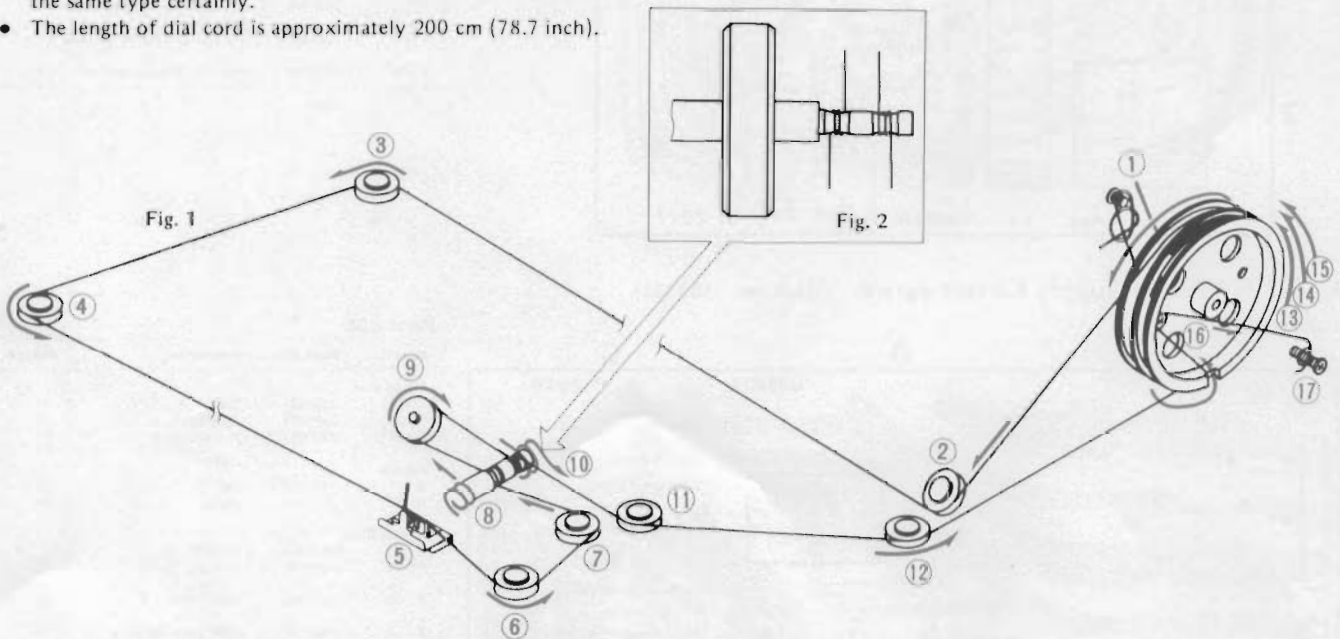

1. Threading of Dial Cord

Thread the dial cord in numerical order from 1 to 17 as Fig. 1.

- Open the variable capacitor completely.

Stock No.	Description
6036050	Dial Cord (0.5 mm φ)
6146721	Dial pulley

2. Attachment of Dial Pointer

(1) Close the variable capacitor completely.

(2) Set the dial pointer to the line at most left on dial scale.

- Confirm that the dial pointer runs smoothly on the dial scale by turning the tuning shaft.

• Design and specifications subject to change without notice for improvement.  
• La présentation et les spécifications sont susceptibles d'être modifiées sans préavis par suites d'améliorations éventuelles.  
• Änderungen, die dem technischen Fortschritt dienen, bleiben vorbehalten.

A	B	C	D
---	---	---	---

# 7. SCHEMATIC DIAGRAM

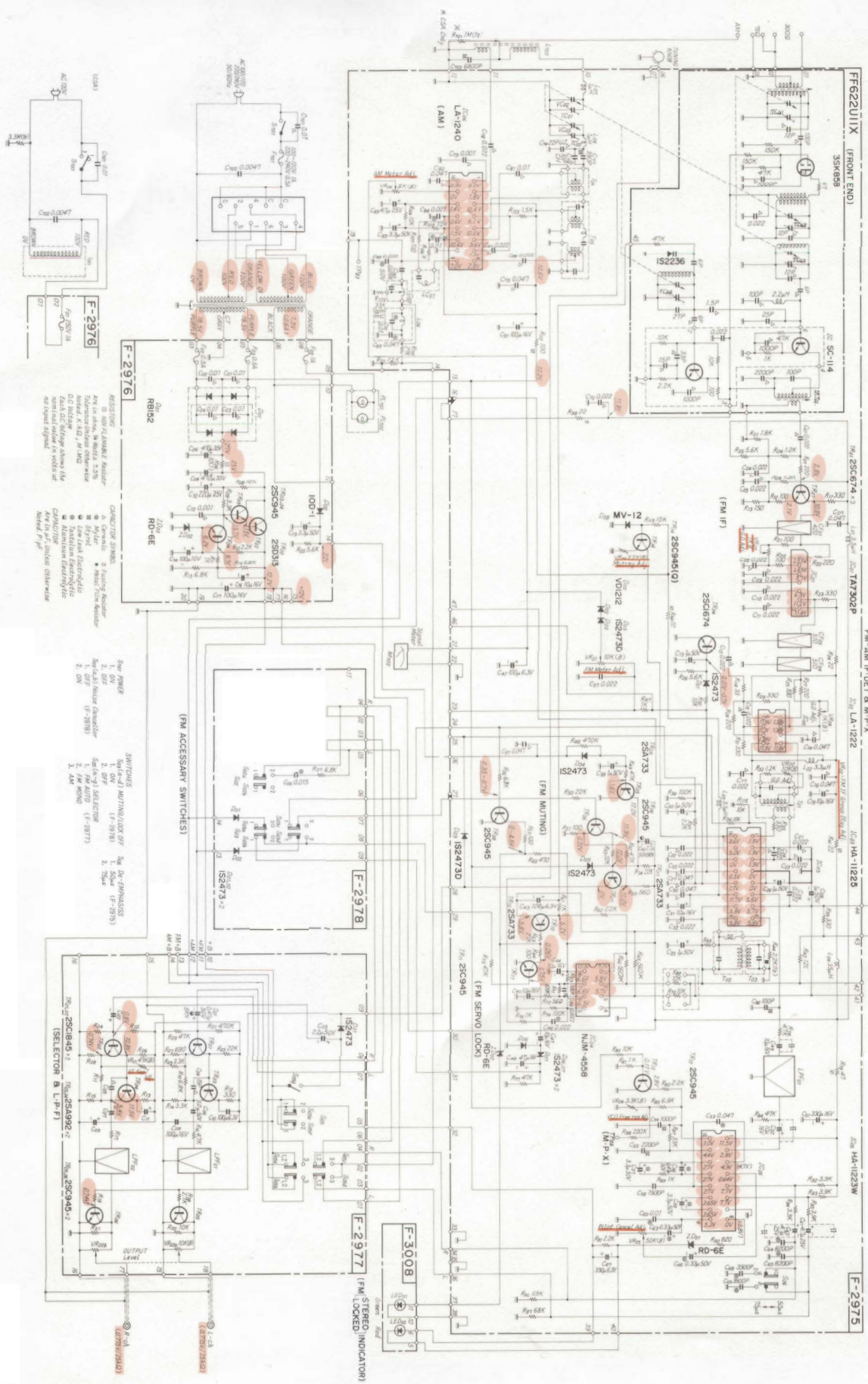

- 1 2SA733A
- 2SA992
- 2SC945
- 2SC1674
- 2SC1845
- 2SD313
- LA-1222 NJM4558D
- TA-7302B
- LA-1240
- HA-1125
- HA-11233W
- RD6E
- 10D-1
- 1S2473D
- MV-12
- RB125

1

2

3

4

5



## 8. PACKING LIST

Parts No.	Stock No.	Description
1	9116790	Vinyl Cover
2	9028320	Stylofoam Packing
3	9001711	Carton Case
4	5996080	Curl Stopper

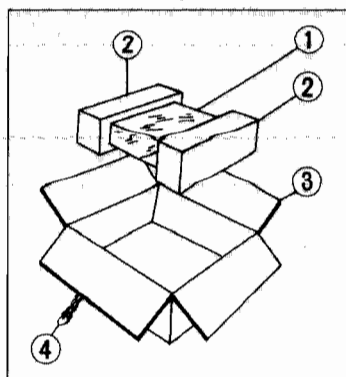

## 9. ACCESSORY PARTS LIST

Stock No.	Description
9204430	Operating Instructions
3820120	FM Antenna
3810320, 1	Pinplug Cord
9238110	Schematic Diagram
5396720	Rack-mounting Adaptor (ea.)

MEMO

SANSUI ELECTRONICS CORPORATION: 1250 Valley Brook Ave. Lyndhurst, N.J. 07071 U.S.A.

333 West Alondra Blvd. Gardena, California 90247 U.S.A.

3036 Koapaka St. Honolulu, Hawaii 96819 U.S.A.

SANSUI AUDIO EUROPE N.V.:

North Trade Bldg (9th floor) Noorderlaan 133-Bus 1, 2030 Antwerp, Belgium

SANSUI AUDIO EUROPE S.A.:

Arabella center, 6 Frankfurt AM Main, Lyoner Strasse 44-48, West Germany

SANSUI ELECTRIC COMPANY LTD.: 14-1, Izumi 2-chome, Sugjnamiku, Tokyo 168 Japan PHONE: (03) 323-1111/TELEX: 232-2076

**Sansui**