

SERVICE MANUAL

AM/FM STEREO TUNER **SANSUI TU-5500**

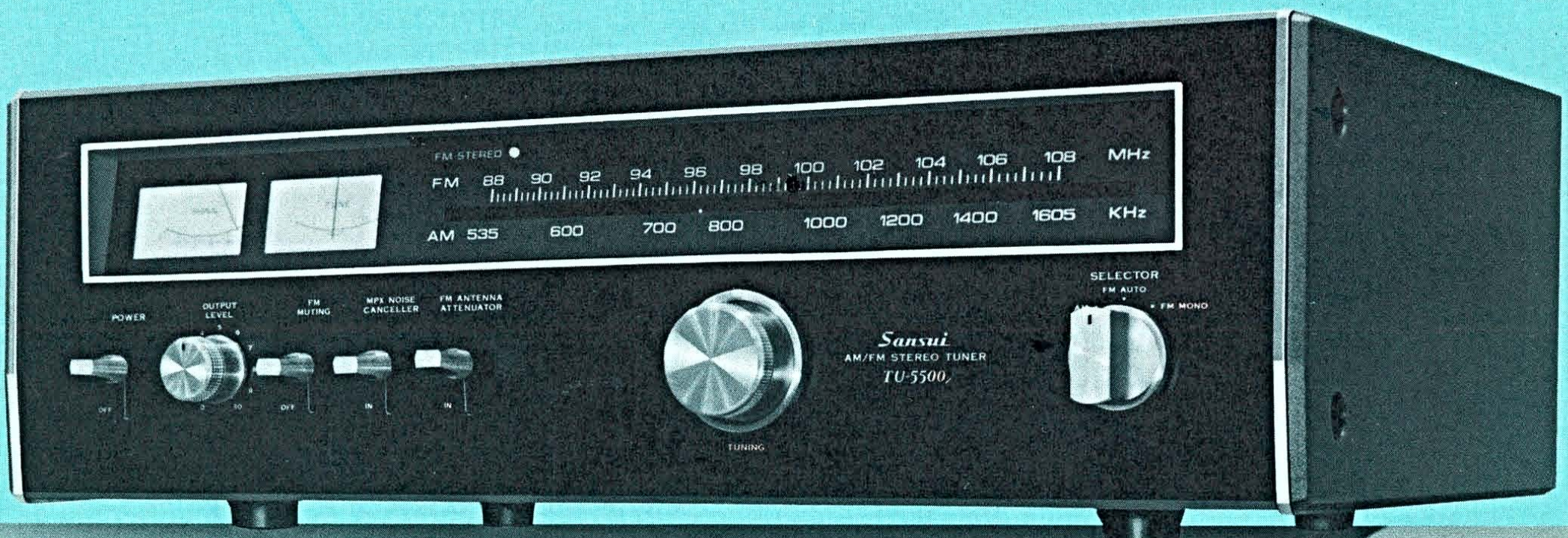

SANSUI ELECTRIC CO., LTD.

This service manual is designed for service engineers to repair, adjust, maintain and order the replacement parts of the TU-5500 correctly.

When ordering the parts, use the stock number and parts name specifically referring to the Parts Locations & Parts List.

For general usage and maintenance of the unit, please refer to the Operating Instructions attached with the unit.

TABLE OF CONTENTS

<u>Section</u>	<u>Title</u>	<u>Page</u>
1.	SPECIFICATIONS	2
2.	BLOCK DIAGRAM	3
3.	ALIGNMENTS AND ADJUSTMENTS	4
3-1.	FM IF Alignment	4
3-2.	FM Dial Calibration, MONO Distortion and RF Alignment	5
3-3.	MPX Alignment	5, 6
3-4.	AM IF, Dial Calibration, RF and Signal Meter Alignment	6
4.	PARTS LOCATIONS AND PARTS LISTS	7
4-1.	F-1506B Tuner Circuit Board.....	7, 8
4-2.	F-1511 Power Supply Circuit Board	8
4-3.	Other Parts (Front Side)	9
4-4.	Other Parts (Top Side).....	10
4-5.	Other Parts (Bottom Side)	10
5.	THREADING OF DIAL CORD	11
6.	TROUBLESHOOTING CHART	12, 13
7.	PACKING LIST	13
8.	ACCESSORY PARTS LIST	13
9.	SCHEMATIC DIAGRAM	14

1. SPECIFICATIONS

FM SECTION

TUNING RANGE88 to 108MHz
SENSITIVITY (IHF)1.9 μ V
TOTAL HARMONIC DISTORTION	
MONOless than 0.3%
STEREOless than 0.4%
SIGNAL TO NOISE RATIO	..better than 70dB
SELECTIVITYbetter than 60dB
CAPTURE RATIO (IHF)less than 2.0dB
IMAGE FREQUENCY REJECTION	
.....better than 55dB
IF REJECTIONbetter than 80dB
SPURIOUS RESPONSE REJECTION	
.....better than 70dB
STEREO SEPARATIONbetter than 40dB at 1KHz
SPURIOUS RADIATIONless than 34dB
FREQUENCY RESPONSE20 to 15,000Hz
FM ANTENNA INPUT IMPEDANCE	
.....300 Ω balanced
.....75 Ω unbalanced
FM ANTENNA ATTENUATOR	
.....-20dB

AM SECTION

TUNING RANGE535 to 1,605KHz
SENSITIVITY (Bar Antenna)	..50dB/m
SELECTIVITYbetter than 30dB
IMAGE FREQUENCY REJECTION	
.....better than 80dB/m at 1MHz
IF REJECTIONbetter than 80dB/m at 1MHz

OTHERS

OUTPUT0 to 0.775V
REC OUTPUT0.4V
SEMICONDUCTORS	
TRANSISTORS9
FET1
ICs4
DIODES8
ZENER DIODE1
LEDs2
POWER REQUIREMENTS	
POWER VOLTAGE100, 117, 220, 240V 50/60Hz
POWER CONSUMPTION	..9W (rated)
DIMENSIONS434mm (17 $\frac{1}{8}$ ") W
130mm (5 $\frac{1}{8}$ ") H
243mm (9 $\frac{9}{16}$ ") D
WEIGHT6.9Kg (15.2 lbs) net
8.3Kg (18.3 lbs) packed

* Design and specifications subject to change without notice for improvement.

2. BLOCK DIAGRAM

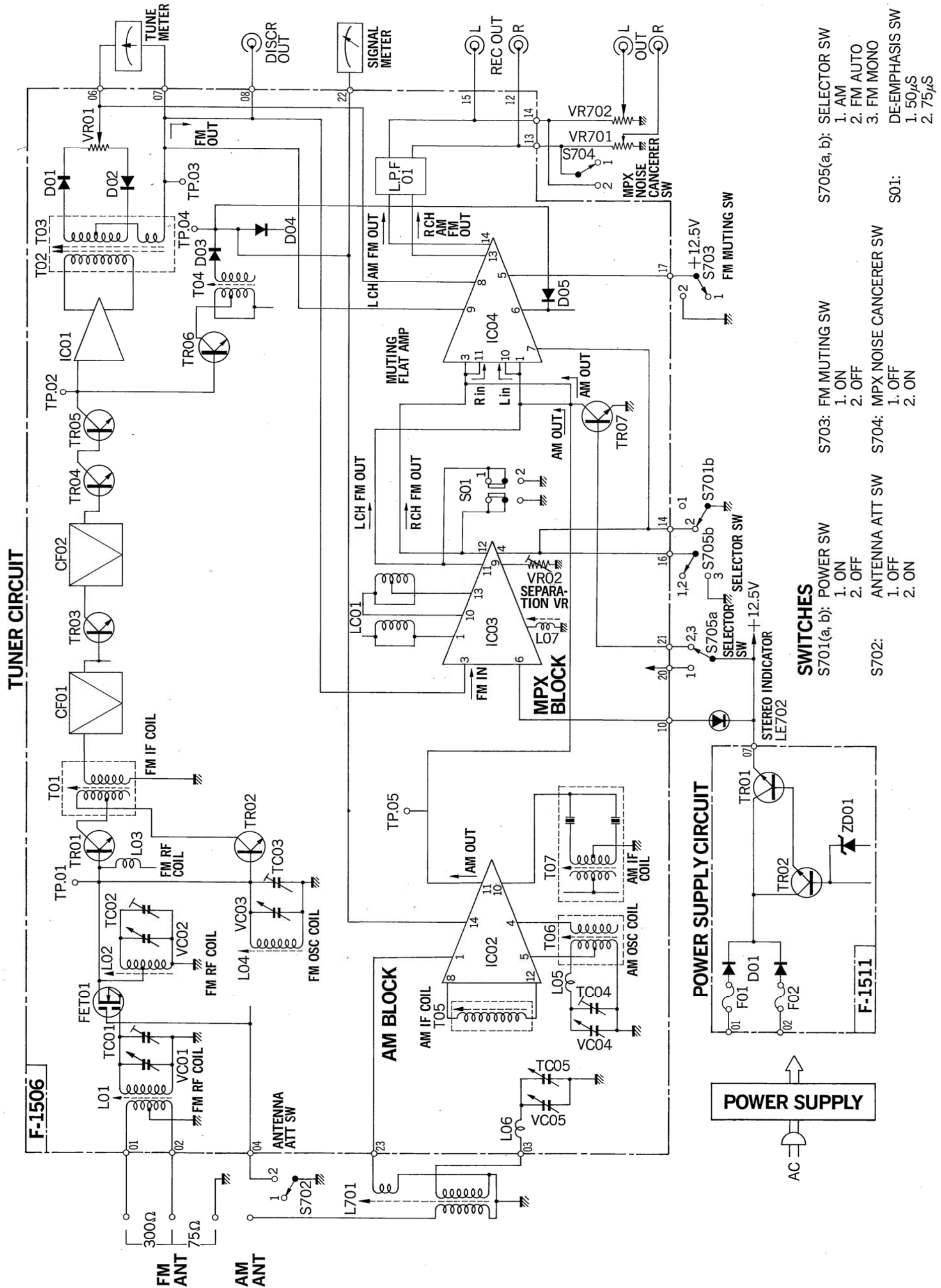

- SWITCHES**
- S701(a, b): POWER SW
 - 1. ON
 - 2. OFF
 - S702: ANTENNA ATT SW
 - 1. OFF
 - 2. ON
 - S703: FM MUTING SW
 - 1. ON
 - 2. OFF
 - S704: MPX NOISE CANCELER SW
 - 1. OFF
 - 2. ON
 - S705(a, b): SELECTOR SW
 - 1. AM
 - 2. FM AUTO
 - 3. FM MONO
 - S01: DE-EMPHASIS SW
 - 1. 50μS
 - 2. 75μS

3. ALIGNMENTS AND ADJUSTMENTS

Abbreviation

Equipment

AM FM Generator Oscilloscope Genescope
 AM Standard Signal Generator AM SSG
 FM Standard Signal Generator FM SSG
 FM Stereo Generator Stereo SG
 Oscilloscope Scope
 Audio Oscillator Audio Osc.
 Distortion Meter Dist. Meter

Others

Clockwise CW.
 Counterclockwise..... CCW.
 Antenna ANT.
 Modulation..... MOD.

3-1. FM IF Alignment (See Figs. 3-4, 3-5 on page 6)

- Note:** 1. Selector.....FM AUTO
 2. Output level of genescope After attenuator
 3. Sweepwidth.....1.5~2cm/150kHz
 4. Frequency band9.5~11.5MHz
 5. Connection Connect the output of genescope to TP. 1 through 100pF ceramic capacitor.
 6. FM MUTING switchOFF.

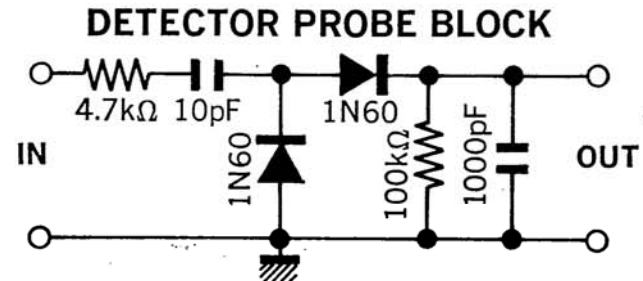
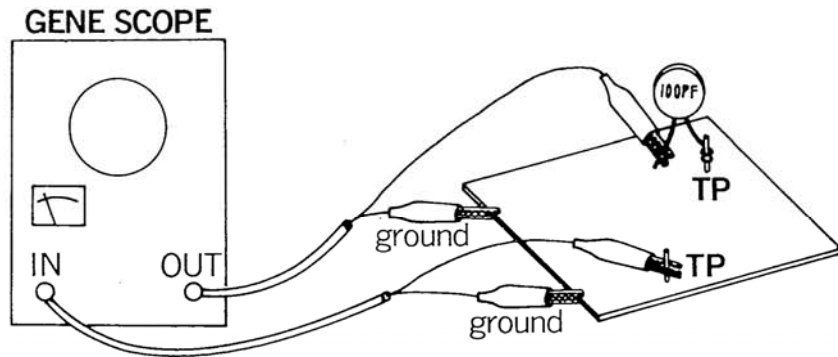

STEP	SUBJECT	FEED SIGNAL		MEASURE OUTPUT	ADJUST	ADJUST FOR	CONDITION
		FROM	TO				
1	IF coil	Output 65dB Genescope	TP. 1 (Fig. 3-5)	TP. 2 (Fig. 3-5) Use Detector Probe	T01 (Fig. 3-5)	Max. IF waveform 1 as (Fig. 3-4)	
2	Meter coil	Output 70dB Genescope	Same as above	TP. 4 (Fig. 3-5)	T04 (Fig. 3-5)	Max. IF waveform 2 (Fig. 3-4) Set the center of waveform 2 with waveform 1 as (Fig. 3-4)	
3	Discriminator coil	Same as above	Same as above	TP. 3 (Fig. 3-5)	T02 T03 (Fig. 3-5)	Max. linearity of S curve Set the center of S curve to of waveform 1 as (Fig. 3-4)	

3-2. FM Dial Calibration, Mono Distortion, TUNE meter and RF Alignment (See Fig. 3-5 on page 6)

- Note:** 1. Selector..... FM AUTO
 2. Confirm start point of dial pointer before alignment.
 3. FM MUTING switch OFF.

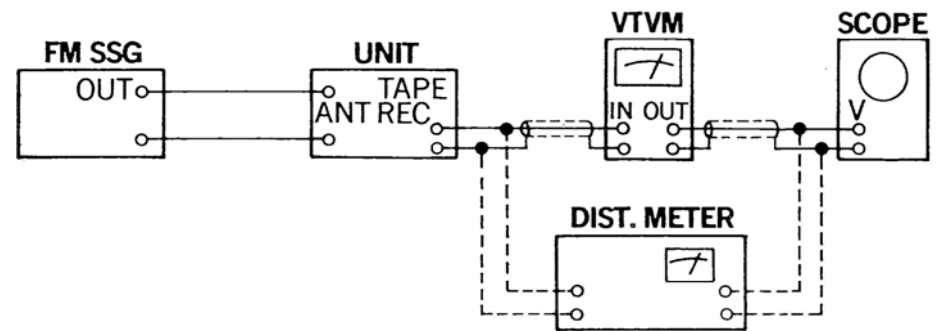

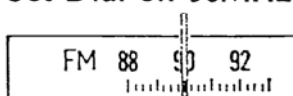
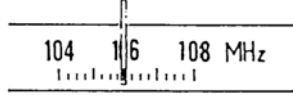
STEP	SUBJECT	FEED SIGNAL		MEASURE OUTPUT	ADJUST	ADJUST FOR	CONDITION
		FROM	TO				
1	90MHz Dial Calibration	90MHz ANT input 60dB 400Hz (100% MOD) FM SSG	ANT terminal 300Ω	REC OUT L or R-ch VTVM & Scope	L04 (Fig. 3-5)	Max. output	◦Set Dial on 90MHz 
2	106MHz Dial Calibration	106MHz ANT input 60dB 400Hz (100% MOD) FM SSG	Same as above	Same as above	Trimmer TC03 (Fig. 3-5)	Same as above	◦Set Dial on 106MHz 
3	Confirm 98MHz Dial Calibration	98MHz ANT input 60dB 1kHz (100% MOD) FM SSG	Same as above	Same as above		Confirm 98MHz Dial Calibration	◦If not, repeat from step 1, 2
4	90MHz RF Adj.	90MHz ANT input 50dB 400Hz (100% MOD) FM SSG	Same as above	Same as above	L01, L02 (Fig. 3-5)	Max. output	◦Tune FM SSG (Max. indication of Signal Meter)
5	106MHz RF Adj.	108MHz ANT input 50dB 400Hz (100% MOD) FM SSG	Same as above	Same as above	Trimmer TC01, TC02 (Fig. 3-5)	Same as above	◦Tune FM SSG (Max. indication of Signal Meter)
6	Distortion	98MHz ANT input 60dB 400Hz (100% MOD) FM SSG	Same as above	REC OUT L or R-ch Dist. meter & Scope	T03 (Fig. 3-5)	Min. distortion	Same as above
7	TUNE meter Volume	Same as above	Same as above	TUNE meter	VR01 (Fig. 3-5)	Center on meter	Same as above

3-3. MPX Alignment (See Fig. 3-5 on page 6)

- Note:** 1. Selector..... FM AUTO
 2. FM MUTING Switch OFF

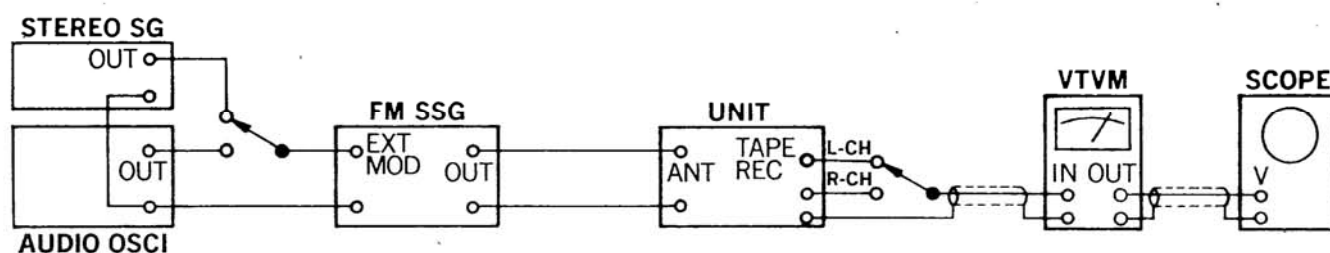

STEP	SUBJECT	FEED SIGNAL		MEASURE OUTPUT	ADJUST	ADJUST FOR	CONDITION
		FROM	TO				
1	19kHz coil	98MHz ANT input 60dB FM SSG Pilot 19kHz (10% MOD) L-ch 1kHz (45% MOD) R-ch (0% MOD) Stereo SG	ANT terminal 300Ω	REC OUT L-ch VTVM & Scope	L07 (Fig. 3-5)	Max. output	◦Tune FM SSG (Max. indication of signal meter)

STEP	SUBJECT	FEED SIGNAL		MEASURE OUTPUT	ADJUST	ADJUST FOR	CONDITION
		FROM	TO				
2	Separation	Same as above	Same as above	REC OUT R-ch VTRM & Scope	VR02 (Fig. 3-5)	Min. output	
3	Confirm Separation	98MHz ANT input 60dB FM SSG Pilot 19kHz (10% MOD) L-ch (0% MOD) R-ch 1kHz (45% MOD) Stereo SG	Same as above	REC OUT L-ch VTRM & Scope		Min. output	◦If less the 40dB adjust VR02

3-4. AM IF, Dial Calibration and RF Alignment

(See Figs. 3-2, 3-3, 3-5 on page 6)

- Note: 1. Selector.....AM
2. Confirm start point of dial pointer before alignment.
 3. In case of using loop antenna, increase output of AM SSG for 26dB than bar antenna's direct input as it attenuates input sensitivity for 26dB (See Fig. 3-1).

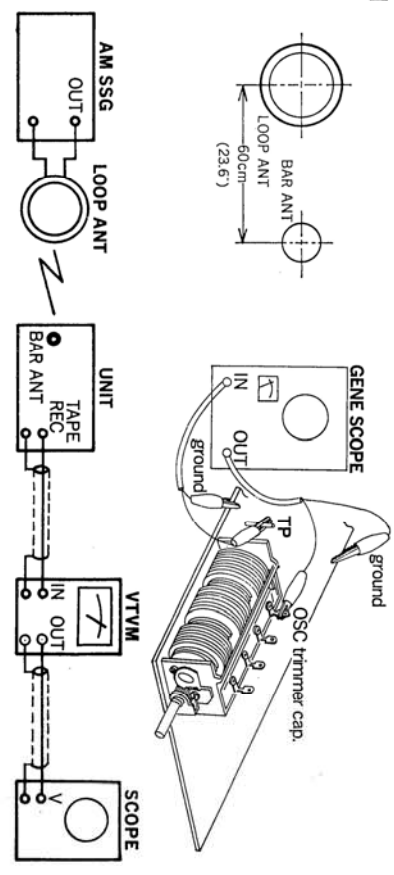

STEP	SUBJECT	FEED SIGNAL		MEASURE OUTPUT	ADJUST	ADJUST FOR	CONDITION
		FROM	TO				
1	IF coil	Output 70dB Genescope	OSC trimmer cap. TC04 (Fig. 3-5)	TP. 5 (Fig. 3-5)	T07 (Fig. 3-5)	Max. IF waveform (Fig. 3-2)	
2	IF coil	Output 60dB Genescope	Same as above	Same as above	T05 (Fig. 3-5)	Max. IF waveform (Fig. 3-3)	◦If not, readjust T07 & T05 slightly
3	IF coil	Output 70dB Genescope	Same as above	Same as above		Max. output	◦If broadcasting station is near, it might be used
4	535kHz Dial Calibration	535kHz ANT input 86dB AM SSG Use Loop ANT	Ba ANT	REC OUT L or R-ch VTRM & Scope	T06 (Fig. 3-5)	Max. output	
5	1400kHz Dial Calibration	1400kHz ANT input 86dB AM SSG Use Loop ANT	Same as above	Same as above	Trimmer TC04 (Fig. 3-5)	Same as above	Same as above
6	Confirm 1000kHz Dial Calibration	1000kHz ANT input 86dB AM SSG Use Loop ANT	Same as above	Same as above		Confirm 1000kHz Dial Calibration	◦If not, repeat from Step 4, 5

STEP	SUBJECT	FEED SIGNAL		MEASURE OUTPUT	ADJUST	ADJUST FOR	CONDITION
		FROM	TO				
7	600kHz RF Adj.	600kHz ANT input 76dB 400Hz (30% MOD) AM SSG Use Loop ANT	Same as above	Same as above	Bar ANT L701	Max. output	
8	1400kHz RF Adj.	1400kHz ANT input 76dB 400Hz (30% MOD) AM SSG Use Loop ANT	Same as above	Same as above	Trimmer TC05 (Fig. 3-5)	Same as above	
9	Confirm 1000kHz RF Adj.	1000kHz ANT input 76dB 400Hz (30% MOD) AM SSG Use Loop ANT	Same as above	Same as above		Confirm 1000kHz RF Adj.	◦If not repeat from step 7, 8

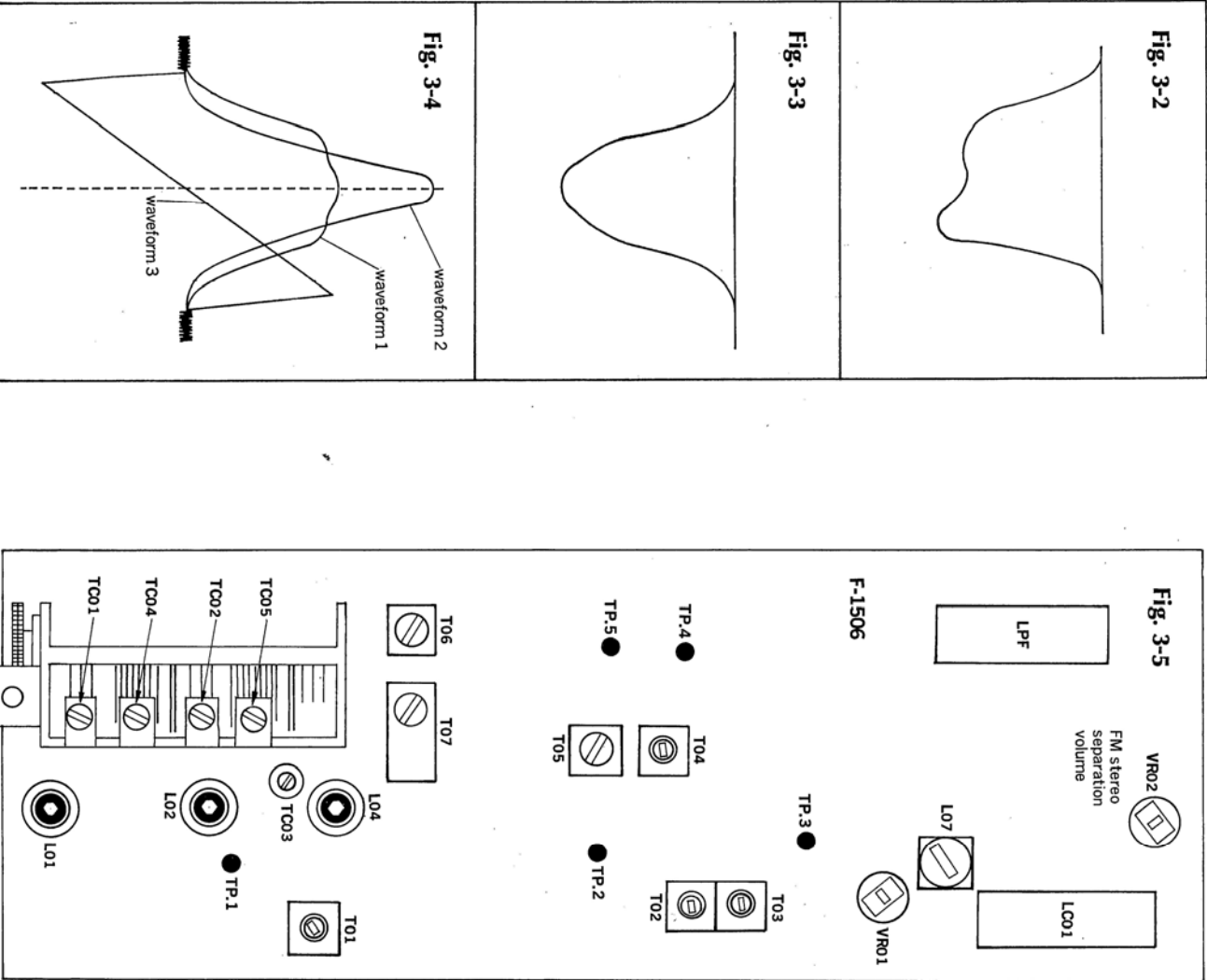
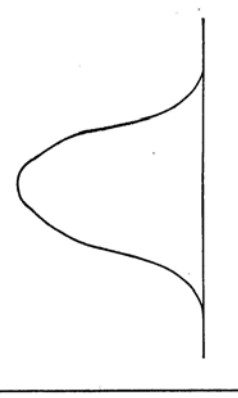
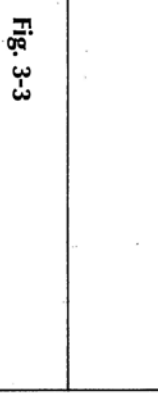
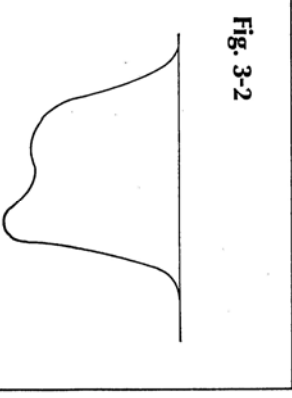

4. PARTS LOCATIONS AND PARTS LISTS

4-1. F-1506B Tuner Circuit Board (Stock No. 7520850 Complete Circuit Board F-1506B)

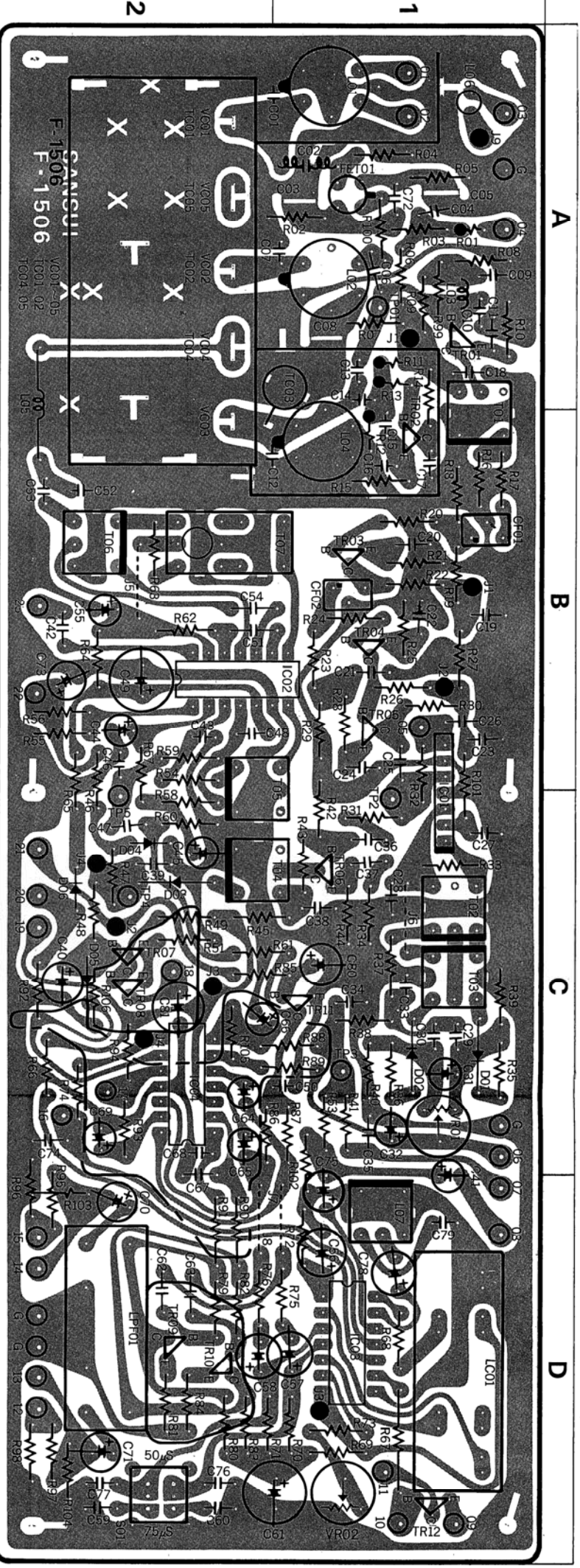

Parts List

Parts No.	Stock No.	Description	Position
TR01	0305801	2SC1047 (B)	1A
TR02	0305790, 1	2SC930 (C, D)	1B
TR03	0306112, 3	2SC738 (C, D)	1B
TR04	0306112, 3	2SC738 (C, D)	1B
TR05	0306112, 3	2SC738 (C, D)	1B
TR06	0306112, 3	2SC738 (C, D)	1B
TR07	0305731, 2	2SC711 (E, F)	2C
IC01	0360120	μPC555H	1B, C
IC02	0360150	HA1151	1, 2B
IC03	0360080	HA1120	1D
IC04	0360140	HA1149	2C
FET01	0370120, 1	3SK41 (L, K) FET	1A
D01	0311060	1N60P	1C
D02	0311060	1N60P	1C
D03	0311160	1S2473	2C
D04	0340090	DS-430	2C
D05	0340090	DS-430	2C
D06	0311160	1S2473 (D)	2C
T01	4235930	FM IF Coil	1A, B
T02	4235750	Discriminator Coil	1C
T03	4235760	Discriminator Coil	1C
T04	4235940	FM Meter Coil	1, 2C
T05	4230620	AM IF Coil	1, 2B, C
T06	4220550	AM OSC Coil	2B
T07	0910270	Ceramic Filter	1, 2B
L01	4200560	FM ANT Coil	1A
L02	4210300	FM RF Coil	1A
L03	4010120	Choke Coil	1A
L04	4220530	FM OSC Coil	1A, B

Parts No.	Stock No.	Description	Position
L05	4290011	3.5μH Peeking Coil	2A, B
L06	4900100	3.3μH Micro Inductor	1A
L07	4240720	19kHz Coil	1D
LC01	4240710	MPX Coil Block	2D
CF01	0910150	Ceramic Filter	1B
CF02	0910150	Ceramic Filter	1B
LPF01	0910220	Low Pass Filter	1D
VC01-05	1220170	AM FM Variable Capacitor	2A
TC01, 02	TC04, 05	AM FM Variable Capacitor	2A
VR01	1035150	22kΩ (B) TUNE Meter Volume	1C
VR02	1035070	1kΩ (B) MPX Separation Volume	1D
C01	0669369	8.2pF	1A
C02	0654102	1000pF	1A
C03	0659015	2200pF	1A
C04	0657223	2200pF	1A
C05	0659015	2200pF	1A
C06	0669370	3.9pF	1A
C07	0669370	10pF	1A
C08	0659015	2200pF	1A
C09	0654102	1000pF	1A
C10	0661220	22pF	1A
C11	0657223	2200pF	1A
C12	0669370	10pF	1A, B
C13	0669200	10pF	1A
C14	0669395	10pF	1A
C15	0669395	10pF	1B
C16	0669370	10pF	1B

Parts No.	Stock No.	Description	Position
C17	0657223	22000pF	1B
C18	0657223	22000pF	1A
C19	0657223	22000pF	1B
C20	0657223	22000pF	1B
C21	0657223	22000pF	1B
C22	0657223	22000pF	1B
C23	0657223	22000pF	1B
C24	0657223	22000pF	1B
C25	0657223	22000pF	1B
C26	0657223	22000pF	1B
C27	0657223	22000pF	1C
C28	0657223	22000pF	1C
C29	0660101	100pF	1C
C30	0660101	100pF	1C
C31	0512100	10μF 50V E.C.	1C

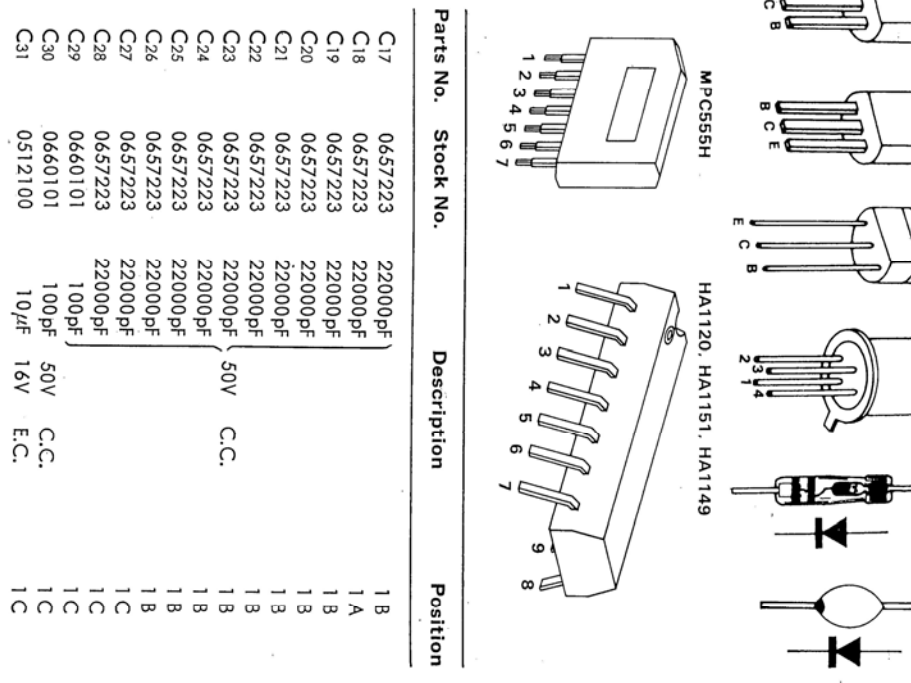

Parts No.	Stock No.	Description	Position
C32	0515109	1μF 50V E.C.	1C
C33	0660101	100pF 50V C.C.	1C
C34	0660101	100pF	1C
C35	0657223	22000pF	1C
C36	0657223	22000pF	1C
C37	0657223	22000pF	1C
C38	0657223	22000pF	1C
C39	0657223	22000pF	2C
C40	0519103	0.47μF 50V E.C.	2C
C41	0512100	10μF 16V E.C.	1C, D
C42	0657223	22000pF 50V C.C.	2B
C43	0601106	0.001μF 50V M.C.	2B
C44	0515109	1μF 50V E.C.	2B
C45	0511100	10μF 10V E.C.	2C
C46	0601107	0.01μF	2B
C47	0601477	0.047μF 50V M.C.	2C
C48	0601107	0.01μF	2B
C49	0512101	100μF 16V E.C.	2B
C50	0601106	0.001μF 50V M.C.	1C
C51	0657223	22000pF	2B
C52	0669215	15pF	2B
C53	0661150	15pF	2B
C54	0601107	0.01μF 50V P.C.	2B
C55	0512100	10μF 16V M.C.	2B
C56	0513479	4.7μF 25V E.C.	1D
C57	0515109	1μF	1D
C58	0515109	1μF	1, 2D
C59	0600826	0.0082μF	M.C.
C60	0600826	0.0082μF	M.C.
C61	0512101	100μF 16V E.C.	1, 2D
C64	0515109	1μF	2C
C65	0515109	1μF	2C
C66	0519339	3.3μF	2C, D
C67	0601686	0.0068μF	1, 2C
C68	0601686	0.0068μF	2C, D
C69	0512100	10μF 16V E.C.	2C
C70	0519105	2.2μF 50V E.C.	2D
C71	0519105	2.2μF	2D
C72	0512221	220μF 16V C.C.	1A
C73	0510470	4.7μF 6.3V E.C.	2B
C74	0600477	0.047μF 50V E.C. (BRN)	2C
C75	0513479	4.7μF 25V E.C.	1D
C76	0600157	0.015μF	2D
C77	0600157	0.015μF	2D
C78	0513479	4.7μF 25V E.C.	1D
C79	0629001	6800pF 50V P.C.	1D
TC03	1230090	Trimmer Capacitor	1, 2A
R01	0106103	10kΩ	1A
R02	0113394	390kΩ	1A
R03	0113103	10kΩ	1A
R04	0113104	100kΩ	1A
R05	0113101	100Ω	1A
R06	0113151	150Ω	1A
R07	0113105	1MΩ	1A
R08	0113220	22Ω	1A
R09	0113562	5.6kΩ	1A
R10	0113123	12kΩ	1A
R11	0113332	3.3kΩ	1A
R12	0106822	8.2kΩ	1A
R13	0106222	2.2kΩ	1A
R14	0106220	2.2kΩ	1A
R15	0113222	22Ω	1A
R16	0113102	1kΩ	1A, B
R17	0113471	470Ω	1B
R18	0113221	220Ω	1B
R19	0113392	3.9kΩ	1B

4-2. F-1511 Power Supply Circuit Board

(Stock No. 7500890 Complete Circuit Board F-1511)

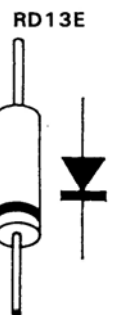
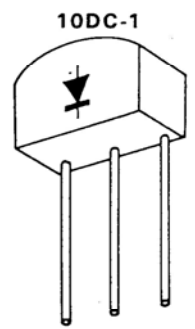
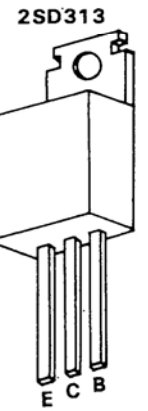
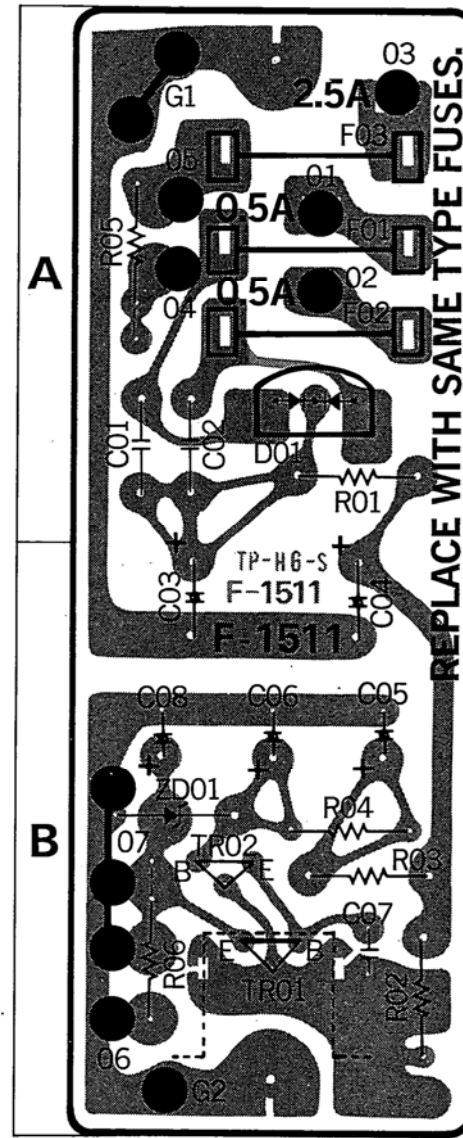

Parts List

Parts No.	Stock No.	Description	Position
TR01	0308392, 3	2SD313 (E, F) } Transistor	B
TR02	0305732, 3	2SC711 (E, G) }	B
D01	0310680	10DC-1 Diode	A
ZD01	0315310	RD13A (N) Zener Diode	B
C01	0659011	0.01 μF } 500V C.C.	A
C02	0659011	0.01 μF }	A
C03	0514471	470 μF } 35V E.C.	B
C04	0514471	470 μF }	B
C05	0513470	47 μF } 25V E.C.	B
C06	0513470	47 μF }	B
C07	0601107	0.01 μF 50V M.C.	B
C08	0512101	100 μF 16V E.C.	B
R01	0103100	10 Ω 1/2W C.R.	A
R02	0107100	10 Ω } 1/4W C.R.	B
R03	0107102	1k Ω }	B
R04	0107391	390 Ω }	B
R05	0192100	10 Ω 1/2W Fuse Resistor	A
R06	0107102	1k Ω 1/4W C.R.	B
F01	0430810	250V 0.5A } Power Fuse	A
F02	0430810	250V 0.5A }	A
F03	0430860	250V 2.5A }	A

Abbreviations

C.R.	: Carbon Resistor	BP.E.C.:	Bi-Polar Electrolytic Capacitor
S.R.	: Solid Resistor	C.C.	: Ceramic Capacitor
Ce.R.	: Cement Resistor	Mi.C.	: Mica Capacitor
M.R.	: Metallized Film Resistor	O.C.	: Oil Capacitor
M.C.	: Mylar Capacitor	P.C.	: Polystyrene Capacitor
E.C.	: Electrolytic Capacitor	T.C.	: Tantalum Capacitor

Parts No.	Stock No.	Description	Position
R19	0113152	1.5kΩ	1 B
R20	0113101	100Ω	1 B
R21	0113182	1.8kΩ	1 B
R22	0113471	470Ω	1 B
R23	0113681	680Ω	1 B
R24	0113101	100Ω	1 B
R25	0113271	270Ω	1 B
R26	0113152	1.5kΩ	1 B
R27	0113220	22Ω	1 B
R28	0113271	270Ω	1 B
R29	0113391	390Ω	1 B
R30	0113681	680Ω	1 B
R31	0113472	4.7kΩ	1 B, C
R32	0113222	2.2kΩ	1 C
R33	0113682	6.8kΩ	1 C
R34	0113331	330Ω	1 C
R35	0113102	1kΩ	1 C
R36	0113102	1kΩ	1 C
R37	0113101	100Ω	1 C
R38	0113471	470Ω	1 C
R41	0113473	47kΩ	1 C
R42	0113103	10kΩ	1 C
R43	0113183	18kΩ	1 C
R44	0113102	1kΩ	1 C
R45	0113101	100Ω	1, 2 C
R46	0113122	1.2kΩ	2 B, C
R47	0113682	6.8kΩ	2 C
R48	0113104	100kΩ	2 C
R53	0113471	470Ω	1 C
R54	0113101	100Ω	2 B
R55	0113122	1.2kΩ	2 B
R56	0113152	1.5kΩ	2 B
R57	0113103	10kΩ	2 B, C
R58	0113103	10kΩ	2 C
R59	0113182	1.8kΩ	2 B
R61	0113183	18kΩ	1, 2 C
R62	0113392	3.9kΩ	2 B
R63	0113224	220kΩ	2 B
R64	0113151	150Ω	2 B
R65	0113560	56Ω	2 B, C
R66	0113334	330kΩ	2 C
R67	0107102	1kΩ	1 D
R68	0113151	150Ω	1 D
R69	0113101	100Ω	1 D
R70	0113332	3.3kΩ	1 D
R71	0113332	3.3kΩ	2 D
R72	0113472	4.7kΩ	1 D
R73	0113151	150Ω	1 D
R74	0113104	100kΩ	2 C
R75	0113223	22kΩ	1 D
R76	0113223	22kΩ	2 D
R85	0113472	4.7kΩ	1, 2 C
R86	0113563	56kΩ	2 C
R87	0113563	56kΩ	1 C
R88	0113223	22kΩ	1 C
R89	0113223	22kΩ	1 C
R90	0113152	1.5kΩ	2 D
R91	0113152	1.5kΩ	2 D
R92	0113224	220kΩ	2 C
R93	0113222	2.2kΩ	2 C
R94	0113222	2.2kΩ	2 C
R95	0113562	5.6kΩ	2 C, D
R96	0113472	4.7kΩ	2 C, D
R97	0113562	5.6kΩ	2 D
R98	0113472	4.7kΩ	2 D
R99	0113221	220Ω	1 A
R100	0113470	47Ω	1 A
R101	0113220	22Ω	1 B, C
S01	1110270	De-Emphasis Switch	2 D
	2260010	Test Pin	

4-3. Other Parts (Front Side)

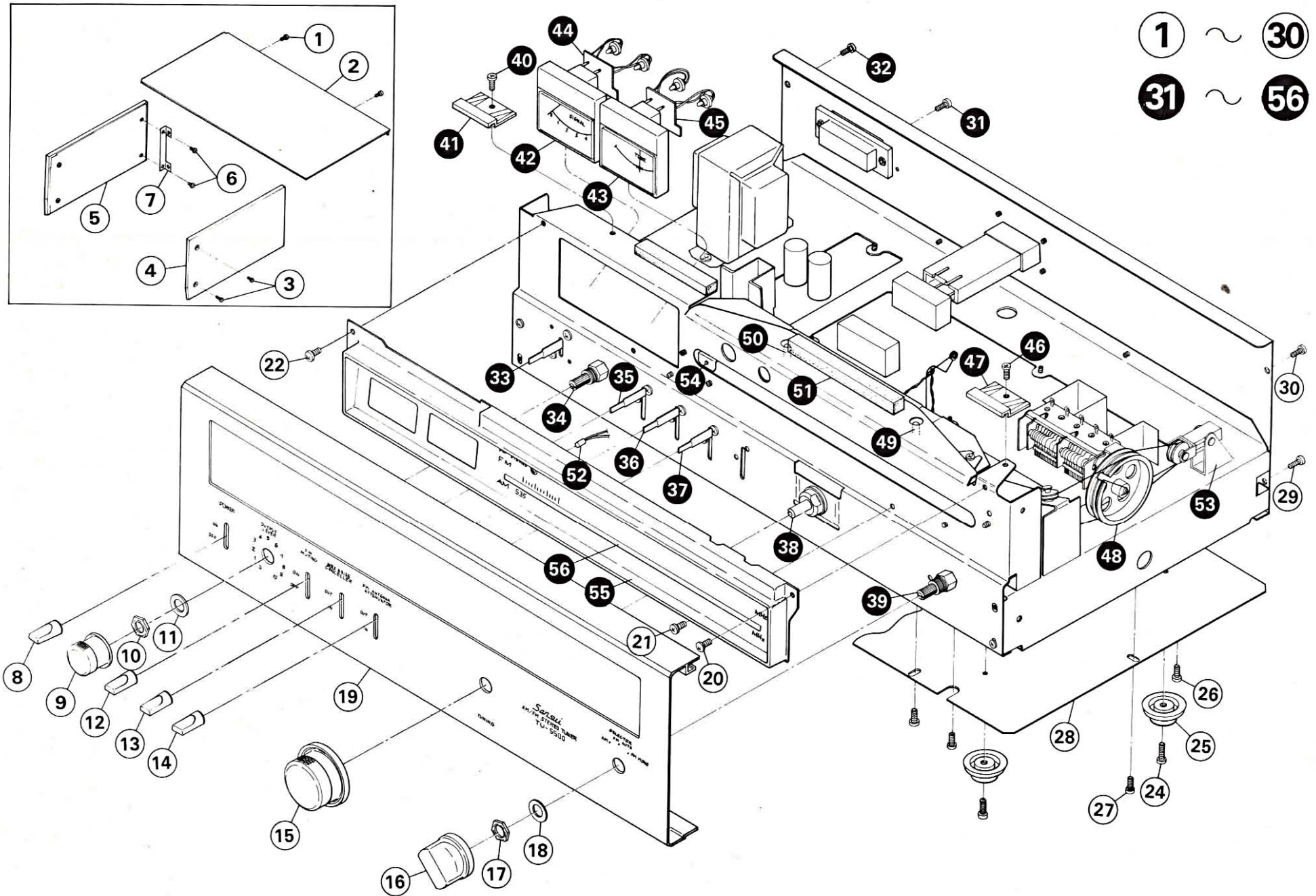

Parts List

Parts No.	Stock No.	Description
1	5101143	Binding Head Screw, M3×6
2	5006330	Bonnet
3	5101161	Binding Head Screw, M4×6
4	5309270	Side Panel R
5	5309260	Side Panel L
6	5109121	Binding Head Tapping Screw, M3×6
7	5269830	Retainer (Side Panel)
8	5326460	Knob (Power Switch)
9	5317880	S-5 TY Type Knob (Level Volume)
10	5110780	Hex. Nut, M8
11	5120183	Plain washer, 8φ
12	5326460	E-1 Type Knob (Muting)
13	5326460	E-1 Type Knob (Noise Canceller)
14	5326460	E-1 Type Knob (Antenna Att.)
15	5317921	T-7 Type Knob (Tuning)
16	5318041	S-5 Metal Type Knob (Selector Switch)
17	5110781	Hex. Nut, M9
18	5120184	Plain Washer, 9φ
19	5309310	Front Panel
20	5101043	Binding Head Screw, M3×6
21	5101043	Binding Head Screw, M3×6
22	5101043	Binding Head Screw, M3×6
23	5309450	Dial Scale Flame
24	5166520	Washer Head Tapping Screw, M3×12
25	5516940	Foot
26	5109222	Binding Head Tapping Screw, M3×8
27	5109222	Binding Head Tapping Screw, M3×8
28	5058211	Bottom Plate

Parts No.	Stock No.	Description
29	5109222	Binding Head Tapping Screw, M3×8
30	5109222	Binding Head Tapping Screw, M3×8
31	5109222	Binding Head Tapping Screw, M3×8
32	5109222	Binding Head Tapping Screw, M3×8
33	1170330	Power Switch
34	1011051	Level Volume
35	1170390	Level Switch (Muting)
36	1170390	Level Switch (Noise Canceller)
37	1170390	Level Switch (FM Antenna Att.)
38	7036391	Tuning Unit Ass'y
39	1101590, 1	Selector Switch
40	5101143	Binding Head Screw, M3×6
41	5269880	Panel Holder
42	4300690	Signal Meter
43	4300680	Tune Meter
44	7726040	Lamp Unit
45	7726040	Lamp Unit
46	5101143	Binding Head Screw, M3×6
47	5269830	Panel Holder
48	6146670	D-44 Pulley
49	0400330	7V 100mA Dial Lamp
50	6400330	7V 100mA Dial Lamp
51	5446191	Cover Plate, Dial Lamp
52	7726090	LED Ass'y)B) FM Stereo Indicator
53	7136050	Tention Unit
54	7726070	Dial Pointer Ass'y
55	5407732	Dial Scale
56	5047770	Smoked Plate

4-4. Other Parts (Top Side)

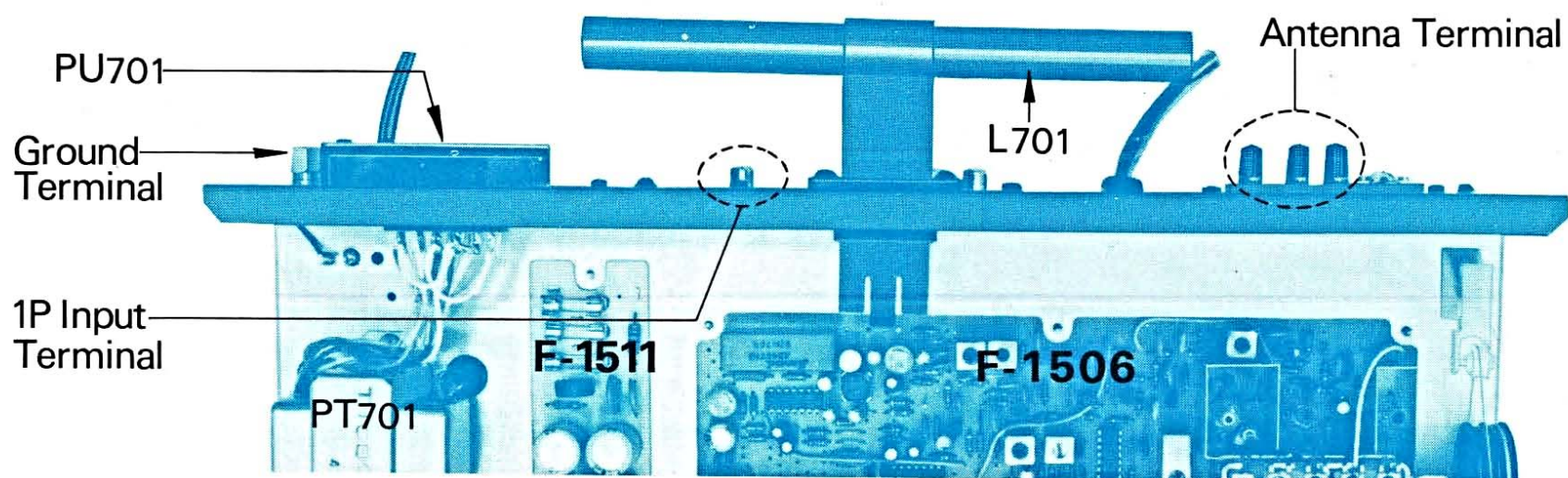

4-5. Other Parts (Bottom Side)

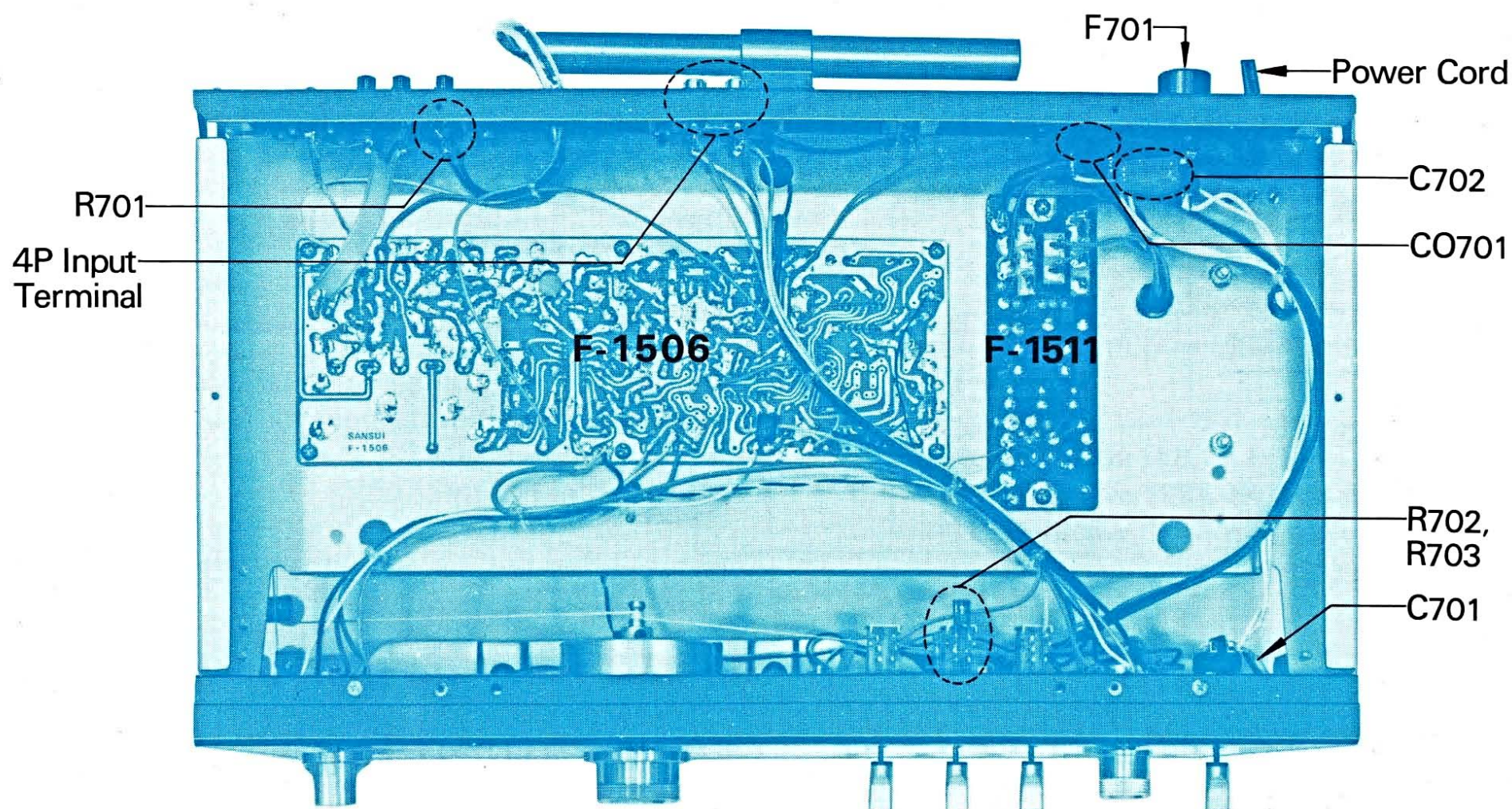

Other Parts List (Top, Bottom Side)

Parts No.	Stock No.	Description	
C701	0659801	0.01 μ F 1.4kV Ceramic Capacitor	
C702	0605477	0.047 μ F 250V } Mylar Capacitor	
C703	0601157		0.015 μ F 50V
R701	0113122		1.2k Ω } $\frac{1}{4}$ W Solid resistor
R702	0113681	680 Ω	
F701	{ 0431222	1A Power fuse (100~117V)	
	{ 0431212	0.5A Power fuse (220~240V)	
	2300060	AC Fuse holder	
CO701	2450060	AC Outlet	

Parts No.	Stock No.	Description
PT701	4002020	Power transformer
	3800090	Power Cord
	2200320	4P Input terminal
	2230051	Ground terminal
L701	2200290	1P Input terminal
	2210190	Antenna terminal
	4200660	Bar Antenna
PU701	{ 2410090	Voltage selector, Plug
	{ 2410080	Voltage selector, Socket
	{ 5268600	Voltage selector, Cover

5. THREADING OF DIAL CORD

* If a dial cord is cut off or slips, replace it by following procedures.

As TU-5500 uses 0.6mm ϕ Cord, please replace it with the same type certainly.

* The length of dial cord is approximately 170cm (66 inch).

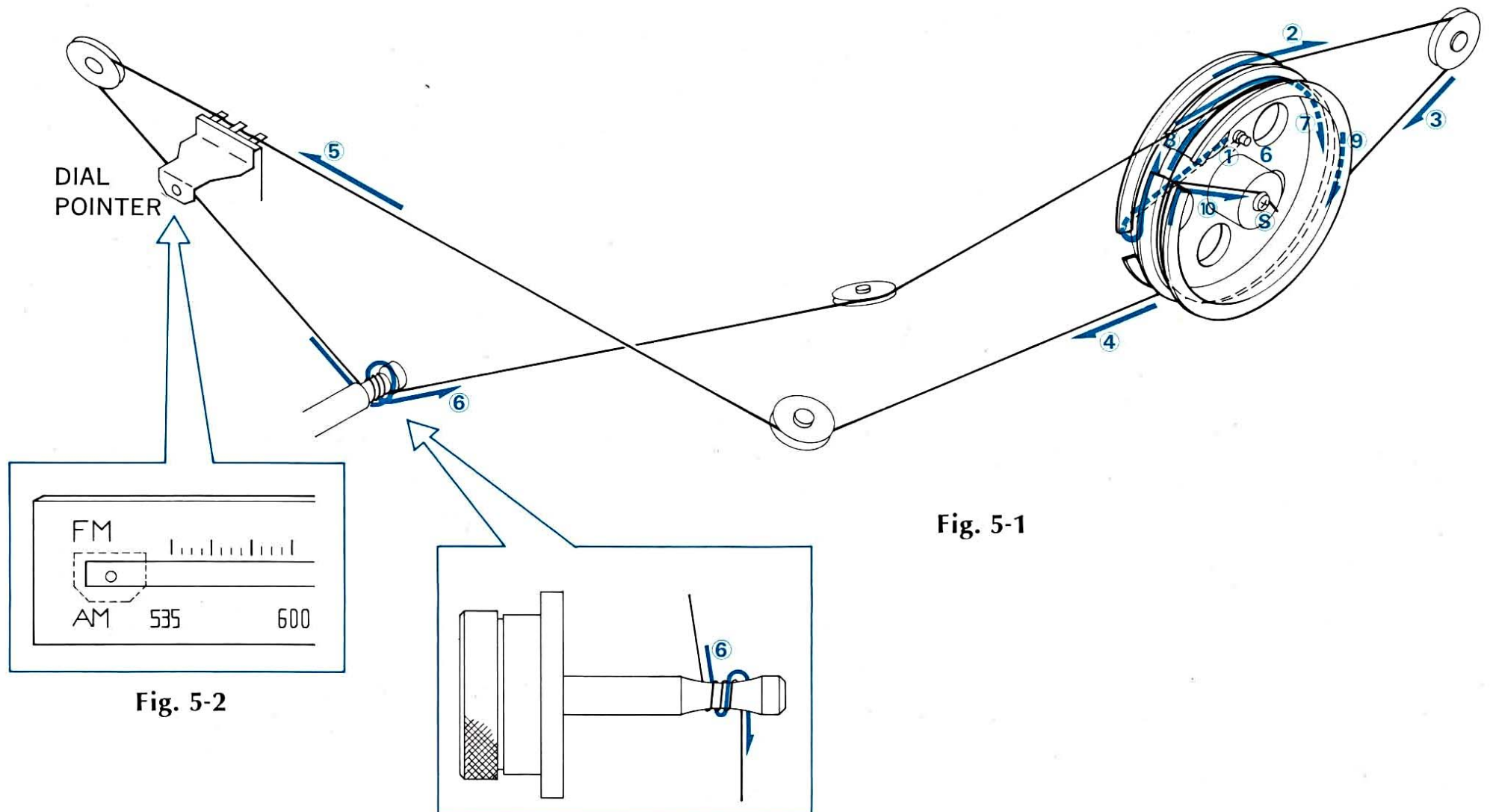

Fig. 5-1

Fig. 5-2

1. Threading of Dial Cord.

Thread the dial cord in numerical order from ① to ⑩ as Fig. 5-1.

- 1) Close the variable capacitor completely (Max. capacitance).
- 2) Only when you replace variable capacitor with new one, turn up the screw ⑤ completely so that the screw 6 on dial pulley is positioned as shown in Fig. 5-1.
- 3) Tie the cord to screw 6 and thread it in the direction of arrow from ① to ⑤
- 4) Then, after winding the cord 3 turns around the tuning shaft counterclockwise, thread it from ⑦ to ⑩.
- 5) After ⑩, tie the cord to the screw ⑥ of the dial pulley.

*To strengthen the dial cord's tension, hold the end of cord, then pull it toward the front panel.

Turn tuning shaft counterclockwise so that the cord's tension will be more obtained.

*After procedure 5), lock the knot ⑩ of the cord and the screw ⑥ with paint.

2. Attachment of Dial Pointer

- 1) Close the variable capacitor completely.
- 2) Set the dial pointer to the position on dial scale as shown in Fig. 5-2.
*Confirm that the dial pointer runs smoothly on the dial scale by turning the tuning shaft.

Stock No.	Description
6036050	Dial Cord (0.6mm ϕ)

6. TROUBLESHOOTING CHART

<Notices when servicing this unit>

○On Light Emitted Diode (LED)

The LED used as Pilot Lamp driven by constant current has characteristics of extreme low reverse break-down voltage (DC 3V) and also it would be easily influenced by discharge voltage from capacitors in power amplifier section.

Therefore, after power switch is turned OFF and lapse of a few seconds, perform the replacement of LED.

○Notice when replacing IC

- 1) Do not vent the leads of IC more than 3 times.
- 2) When using a soldering iron, IC should be absolutely isolated from current leakage of the iron. In

order to protect IC against break-down, connect a lead wire from the iron to ground (chassis) as shown below. (Fig. 6-1)

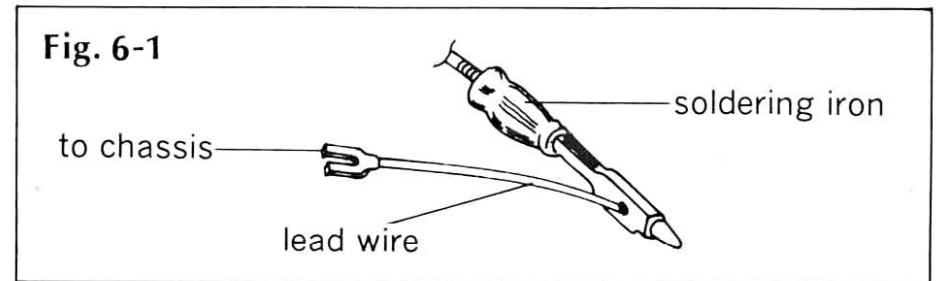

- 3) As IC is extremely weak against heat, use a soldering iron as shorter as possible.

6-1. Troubleshooting on Power Supply Section

Symptom	Check Point	Cause & What to Do
1. No power supplied to each section		
1-1. Each lamp not lighted		<ol style="list-style-type: none"> 1. Imperfect contact of power supply plug 2. Defective power switch S701 3. Imperfect contact of voltage selector PU-701 4. Power fuse F701 open 5. F03 on F-1511 open 6. Defective power transformer, PT701
1-2. Power indicator lamp not lighted		
1) +12V not supplied to terminal [07] on F-1511		<ol style="list-style-type: none"> 7. F01, F02 on F-1511 open 8. Defective D01 on F-1511 9. Defective TR01, TR02 on F-1511 10. Defective ZD01 on F-1511
2) +12V supplied to terminal [07] on F-1511		<ol style="list-style-type: none"> 11. Defective Light Emitted Diode LED701

6-2. Troubleshooting on Tuner Section

1. FM and AM inoperative

1-1. +12V not supplied to terminal [19], [20], [21] on F-1506	1. Defective power supply section (F-1511)
1-2. +12V supplied to terminal [19], [20], [21] on F-1506	<ol style="list-style-type: none"> 2. Defective LPF01 on F-1506 3. Defective IC04 on F-1506

2. FM Section

* Before check, set MUTING switch to OFF

2-1. FM inoperative only

1) Signal meter inoperative	<ol style="list-style-type: none"> 4. IF, RF out of adjustment on F-1506 5. Defective L01~L04 on F-1506 6. Defective T01 on F-1506 7. Defective FET01 on F-1506 8. Defective TR01~TR05 on F-1506 9. Defective CF01, CF02 on F-1506
2) Signal meter operative	<ol style="list-style-type: none"> 10. Defective IC01 on F-1506 11. Defective T02, T03 on F-1506 12. Defective D01, D02 on F-1506

to be continued

Symptom	Check Point	Cause & What to Do
2-2. Stereo indicator lamp not lighted	1) No channel separation on FM stereo broadcasting 1-1) MPX output signals including Rand L not supplied to 11 and 12 of IC03 on F-1506	13. Defective IC03 on F-1506 14. L07 out of adjustment on F-1506 15. Defective L07 on F-1506 16. Defective LC01 on F-1506 17. Defective VR02 on F-1506
	2) Operative channel separation on FM stereo broadcasting	18. Defective Light Emitted Diode LED702
2-3. Signal meter inoperative (FM broadcasting sound can be heard)		19. Defective TR06 on F-1506 20. Defective T04 on F-1506 21. Defective D03, D04 on F-1506 22. Defective signal meter
2-4. Muting circuit inoperative (FM Section will be inoperative when the Muting is switched ON)		23. Defective muting switch S703 24. RF, IF out of adjustment on F-1506 25. Defective FM Antenna Attenuator S702

3. AM Section

3-1. AM inoperative	1) Signal meter operative (AM broadcasting sound can not be heard)	26. Defective TR07 on F-1506 27. Defective IC04 28. Defective LPF01 on F-1506
	2) Signal meter-inoperative (AM broadcasting sound can not be heard)	29. Shorted IC02 on F-1506 30. Defective T05~T07 on F-1506 31. Defective L05, L06 on F-1506 32. Opened coil of Bar Antenna L701 33. Uncomplete tracking IF adjustment

7. PACKING LIST

Parts No.	Stock No.	Description
1	9116640	Vinyl Cover
2	9027790	Stylofoam Packing
3	9008032	Carton Case

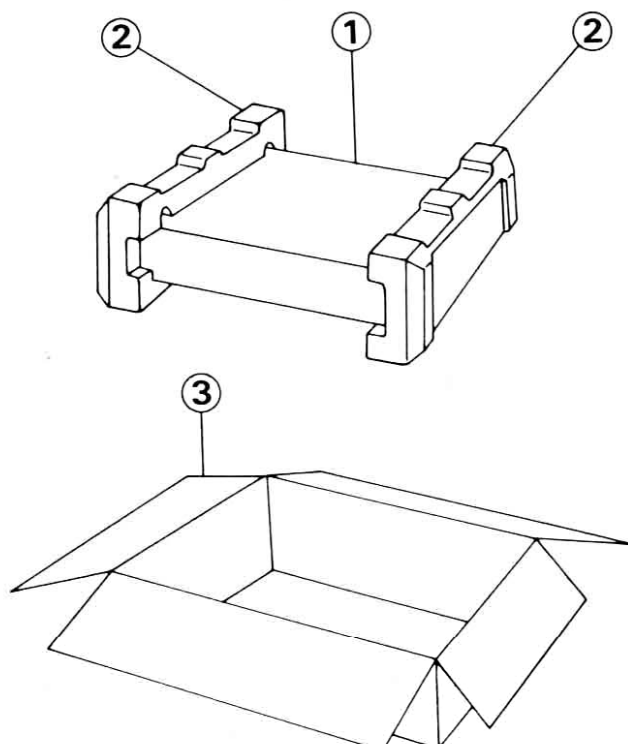

8. ACCESSORY PARTS LIST

Stock No.	Description
3820091	FM Antenna
3810180	Pinplug Cord
9208370	Operating instructions
9228370	Operating instruction sheet

9. SCHEMATIC DIAGRAM

* Design and specifications subject to change without notice for improvements.

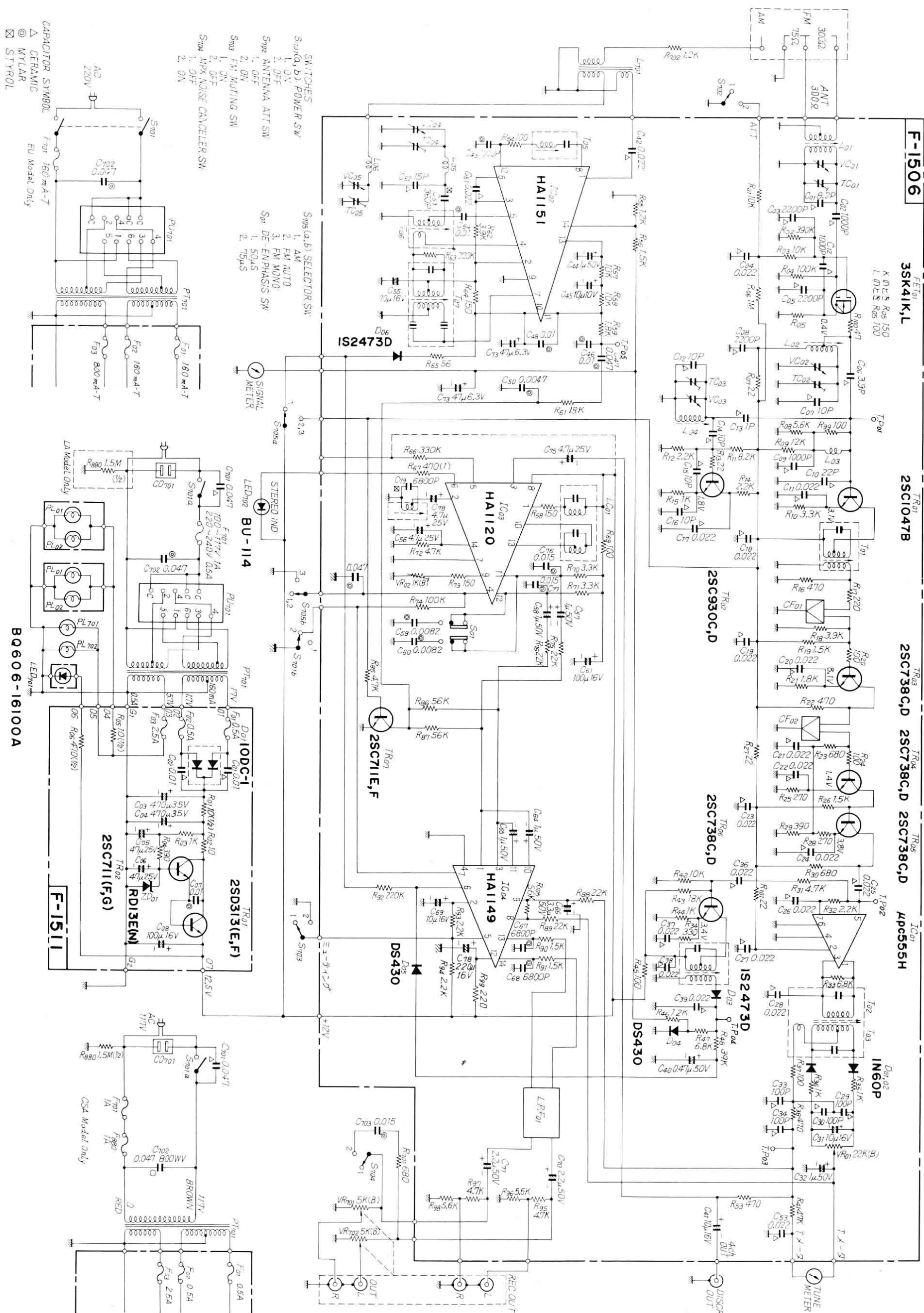



SANSUI ELECTRIC CO., LTD.

14-1, 2-chome, Izumi, Suginami-ku, Tokyo 168, Japan
TELEPHONE: (03) 323-1111/TELEX: 232-2076