

# SERVICE MANUAL

## AM/FM STEREO TUNER **SANSUI TU-5900**

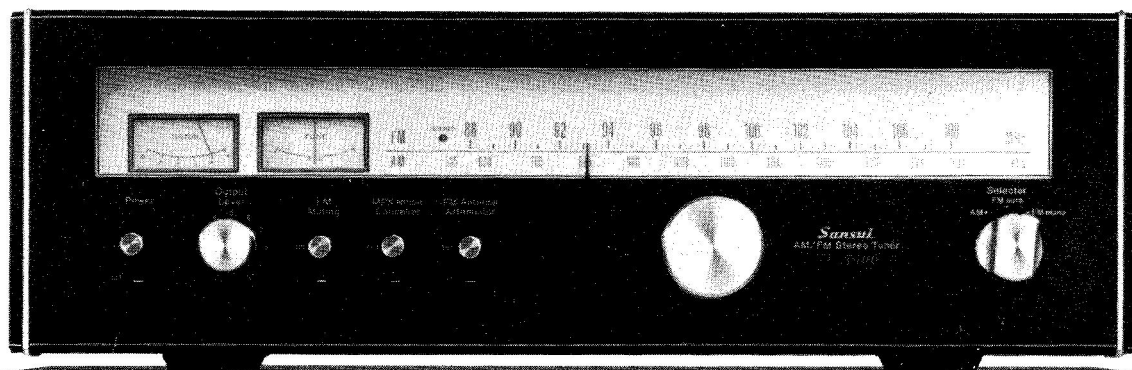

**Sansui**

SANSUI ELECTRIC CO., LTD.

# 1. SPECIFICATIONS

## FM SECTION

TUNING RANGE..... 88 to 108 MHz  
 USABLE SENSITIVITY (IHF) .. 10.3dBf (1.8 $\mu$ V)  
 (DIN) .. 1.0 $\mu$ V (1 kHz, Modulation  
 30% S/N 26dB)  
 MAX. INPUT CAPABILITY... more than 125dBf  
 50dB QUIETING SENSITIVITY  
 STEREO (IHF) ..... 38dBf (45 $\mu$ V)  
 MONO (IHF) ..... 16dBf (3.5 $\mu$ V)  
 TOTAL HARMONIC DISTORTION  
 STEREO..... less than 0.35% (1 kHz)  
 MONO..... less than 0.25% (1 kHz)  
 SIGNAL TO NOISE RATIO  
 STEREO..... better than 60dB  
 MONO..... better than 70dB  
 ALTERNATE CHANNEL SELECTIVITY  
 ..... better than 60dB ( $\pm$ 400 kHz)  
 CAPTURE RATIO ..... less than 2.0dB  
 AM SUPPRESSION..... better than 55dB  
 IMAGE RESPONSE RATIO (IHF)  
 ..... better than 50dB (98 MHz)  
 IF RESPONSE RATIO (IHF) .. better than 75dB (98 MHz)  
 SPURIOUS RESPONSE RATIO (IHF)  
 ..... better than 65dB (98 MHz)  
 SPURIOUS RADIATION .... less than 34dB  
 STEREO SEPARATION ..... better than 30dB (100 Hz)  
 better than 40dB (1 kHz)  
 better than 30dB (10 kHz)  
 FREQUENCY RESPONSE (IHF)  
 ..... +1.0dB, - 2.0dB (30 to  
 15,000 Hz)

ANTENNA IMPEDANCE .... 300 ohms balanced  
 75 ohms unbalanced

FM ANTENNA ATTENUATION  
 ..... -20dB

## AM SECTION

TUNING RANGE..... 535 to 1,605 kHz  
 SENSITIVITY (Bar antenna) .. 50dB/m (1,000 kHz)  
 SELECTIVITY ..... better than 30dB (1,000 kHz)  
 IMAGE RESPONSE RATIO .. better than 30dB (1,000 kHz)  
 IF RESPONSE RATIO ..... better than 30dB (1,000 kHz)

## OTHERS

OUTPUT LEVEL (FM 100% modulation)  
 OUTPUT ..... 0 to 775 mV  
 DOLBY FM ..... 200 mV  
 POWER REQUIREMENTS .... 100, 120, 220, 240V, 50/60Hz  
 120V (Usable 110-130V)  
 60 Hz (For U.S.A. & Canada  
 only)  
 POWER CONSUMPTION.... 18W (rated)  
 DIMENSIONS ..... 430 mm (16-15/16") W  
 132 mm (5-1/4") H  
 243 mm (9-9/16") D  
 WEIGHT ..... 6.4 kg (14.1 lbs) net  
 7.5 kg (26.5 lbs) packed

\*Design and specifications subject to change without notice for improvements.

# TABLE OF CONTENTS

<u>Section</u>	<u>Title</u>	<u>Page</u>
<b>1.</b>	<b>SPECIFICATIONS</b> .....	<b>1</b>
<b>2.</b>	<b>ADJUSTMENT</b> .....	<b>2</b>
2-1.	FM & MPX Adjustment & Alignment .....	<b>2, 3</b>
2-2.	AM IF Adjustment & Tracking .....	<b>4</b>
<b>3.</b>	<b>PARTS LOCATION &amp; PARTS LIST</b> .....	<b>5</b>
3-1.	F-2590 AM, FM, MPX Circuit Board .....	<b>5, 6</b>
3-2.	F-1511 Power Supply Circuit Board .....	<b>6</b>
3-3.	Figures of Semiconductor .....	<b>6</b>
◇	<b>COMMON PARTS LIST FOR RESISTORS &amp; CAPACITORS ONLY</b> .....	<b>(Attached)</b>
<b>4.</b>	<b>OTHER PARTS</b> .....	<b>6, 7</b>
<b>5.</b>	<b>TROUBLESHOOTING CHART</b> .....	<b>7</b>
<b>6.</b>	<b>OPERATION BLOCK DIAGRAM</b> .....	<b>8</b>
6-1.	Block Diagram .....	<b>8</b>
6-2.	PLL Block Diagram (IC HA1196) .....	<b>8</b>
6-3.	FM IF System Block Diagram (IC HA1137W) .....	<b>8</b>
<b>7.</b>	<b>SCHEMATIC DIAGRAM</b> .....	<b>9</b>
<b>8.</b>	<b>THREADING OF DIAL CORD</b> .....	<b>10</b>
<b>9.</b>	<b>PACKING LIST</b> .....	<b>BACK COVER</b>
<b>10.</b>	<b>ACCESSORY PARTS LIST</b> .....	<b>BACK COVER</b>

## 2. ADJUSTMENT

### 2-1. FM & MPX Adjustment & Alignment

- Note:** 1. Selector.....FM AUTO  
 2. FM Muting Switch.....OFF  
 3. Connection.....Connect the output of genescope to TP through 100pF ceramic capacitor.

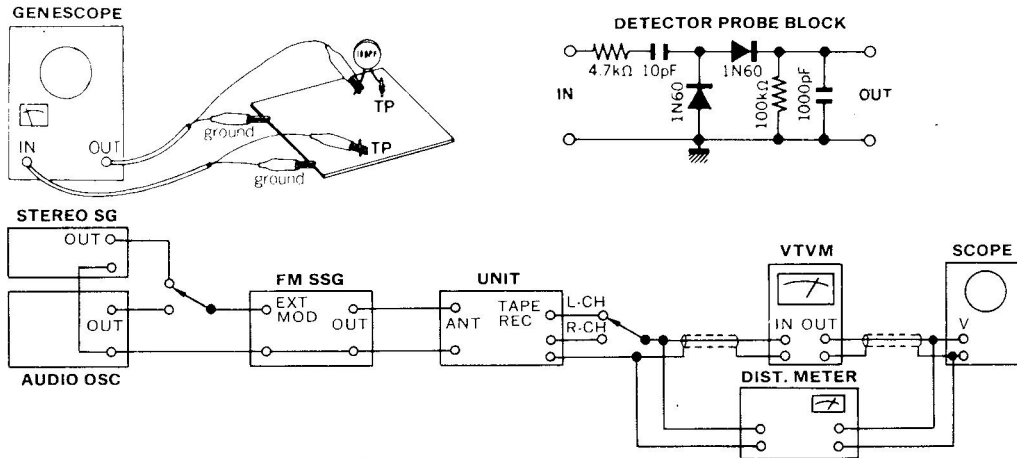

#### 1) FM IF Adjustment & Tracking

STEP	SUBJECT	FEED SIGNAL		MEASURE OUTPUT	ADJUST	ADJUST FOR	CONDITION
		FROM	TO				
1.	IF Coil	Output 60dB Genescope	TP01 F-2590	TP03 F-2590 Use Detector Probe	T01 F-2590	Max. IF waveform	
2.	Discriminator Coil	Output 50dB Genescope	Same as above	TP04 F-2590	T02  T03 F-2590	Center indication on tune meter  Max. linearity of S curve  Steep linearity of S curve  Set output wave to dip point (It's minimum distortion)	
3.	90MHz Dial Calibration	90MHz ANT Input 60dB 400Hz (100% MOD) FM SSG	ANT terminal 300Ω	REC OUT L or R-CH VTVM & Scope	L03 F-2590	Max. Output	
	106MHz Dial Calibration	106MHz ANT Input 60dB 400Hz (100% MOD) FM SSG	Same as above	Same as above	TC03 F-2590	Same as above	
4.	90MHz RF Adj.	90MHz ANT Input 60dB 400Hz (100% MOD) FM SSG	Same as above	Same as above	L01, L02 F-2590	Same as above	
	106MHz RF Adj.	106MHz ANT Input 60dB 400Hz (100% MOD) FM SSG	Same as above	Same as above	TC01 TC02 F-2590	Same as above	
5.	Signal Meter Volume	98MHz ANT Input 60dB 400Hz (100% MOD) FM SSG	Same as above	Signal Mete	VR02 F-2590	4.3 on Meter	





## 2-2. AM IF Adjustment & Tracking

**Note:** Selector.....AM  
 2. Confirm start point of dial pointer before alignment.

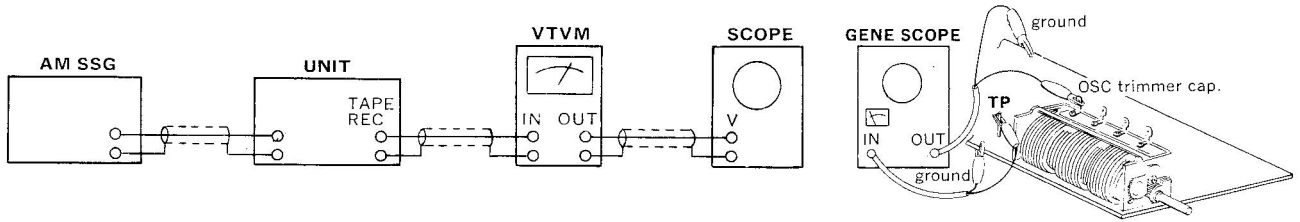

STEP	SUBJECT	FEED SIGNAL		MEASURE OUTPUT	ADJUST	ADJUST FOR	CONDITION
		FROM	TO				
1.	IF Coil	Genescope Output 65dB	TC04 F-2590	TP06 F-2590	CF04 F-2590	Max. IF waveform	
2.	600kHz Dial Calibration	600kHz ANT Input 60dB 400Hz (MOD 30%) AM SSG	AM ANT terminal	REC OUT L or R-CH VTVM & Scope	T04 F-2590	Max. Output	
	1400kHz Dial Calibration	1400kHz ANT Input 60dB 400Hz (MOD 30%) AM SSG	Same as above	Same as above	TC05 F-2590	Same as above	
3.	600kHz RF Adj.	600kHz ANT Input 60dB 400Hz (MOD 30%) AM SSG	Same as above	Same as above	L702 Bar Antenna	Same as above	
	1400kHz RF Adj.	1400kHz ANT Input 60dB 400Hz (MOD 30%) AM SSG	Same as above	Same as above	TC04 F-2590	Same as above	
4.	Signal Meter volume	1000kHz ANT Input 80dB 400Hz (MOD 30%) AM SSG	Same as above	Signal Meter	VR06 F-2590	4.1 on meter	

### Abbreviations

#### Equipment

AM FM Generator Oscilloscope ..... Genescope  
 AM Standard Signal Generator ..... AM SSG  
 FM Standard Signal Generator ..... FM SSG  
 FM Stereo Generator ..... Stereo SG  
 Oscilloscope ..... Scope  
 Audio Oscillator ..... Audio Osc.  
 Distortion Meter ..... Dist. Meter

#### Others

Clockwise ..... CW.  
 Counterclockwise ..... CCW.  
 Antenna ..... ANT.  
 Modulation ..... MOD.

### 3. PARTS LOCATION & PARTS LIST

3-1. F-2590 AM, FM, MPX Circuit Board (Stock No. 7521251)

Conductor Side

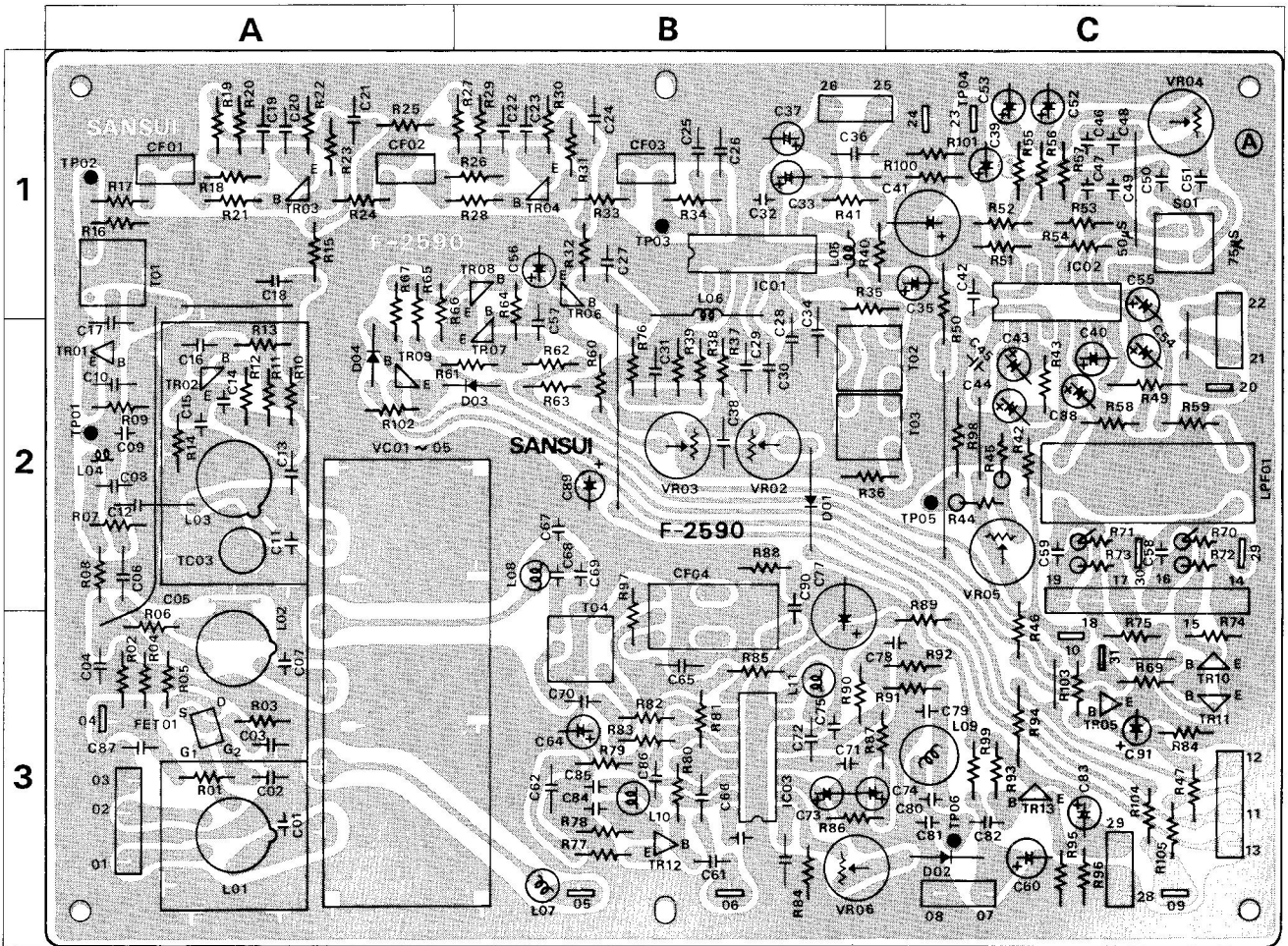

#### Parts List

Parts No.	Stock No.	Description	Position	Parts No.	Stock No.	Description	Position
TR01	0305801	2SC1047 (B)	2 A	D01	0340120	VD1212 Varistor	2 B
TR02	0305801	2SC1047 (B)	2 A	D02	0310330, 1	1N60	3 C
TR03	0306113	2SC738 (D)	1 A	D03	0311160	1S2473D } Diode	2 B
TR04	0306112	2SC738C	1 B	D04	0310330, 1	1N60	2 B
TR05	0305731, 2	2SC711 (E, F)	3 C	C05	0659015	2200 pF 50V C.C.	2 A
TR06	0305731, 2	2SC711 (E, F)	1 B	C12	0679012	1.5 pF 500V G.C.	2 A
TR07	0305731, 2	2SC711 (E, F)	2 B	C40	0573228	0.22 μF	2 C
TR08	0305731, 2	2SC711 (E, F)	1 B	C43	0573339	3.3 μF 35V T.C.	2 C
TR09	0300470	2SA726 (F)	2 A	C44	0573159	1.5 μF	2 C
TR10	{0305641	2SC735 (Y)	3 C	C45	0629005	360 pF 50V P.C.	2 C
	{0306390	2SC1636-1		C48	0620101	100 pF	1 C
TR11	{0305641	2SC735 (Y)	3 C	C49	0620101	100 pF	1 C
	{0306390	2SC1636-1		C50	0620561	560 pF } 50V P.C.	1 C
TR12	0300283	2SA628 (F)	3 B	C51	0620561	560 pF	
TR13	0305731	2SC711 (E, F)	3 C	C69	0620361	360 pF 50V P.C.	2 B
IC01	0360350	IC HA1137 (W)	1 B	L01	4200720	Antenna Coil	3 A
IC02	0360320	IC HA1196	1 C	L02	4210340	RF Coil	3 A
IC03	0360150	IC HA-1151	3 B	L03	4220400	OSC Coil	2 A
FT01	0370131, 2	3SK41 (I) (L, K) FET		L04	4290110	Choke Coil	2 A
				L05	4290280	Inductor	1 B

Parts No.	Stock No.	Description	Position
L06	4290011	Choke Coil	1 B
L07	4900100	Inductor	3 B
L08	4900100		2 B
L09	4900220		3 C
L10	4900110		3 B
L11	4900110		3 B
T01	4235930	IF Coil	1 A
T02	4235970		2 B, C
T03	4235980		2 B, C
T04	4220650	OSC Coil	3 B
CF01	0910150	10.7MHz Ceramic Filter	1 A
CF02	0910150	10.7MHz	Ceramic Filter
CF03	0910150	10.7MHz	
CF04	0910280	455kHz Ceramic Filter	2, 3 B

Parts No.	Stock No.	Description	Position
LF01	0910220	19kHz Low Pass Filter	
VR02	1035170	47kΩ (B)	2 B
VR03	1035190	100kΩ (B)	2 B
VR04	1035210	220kΩ (B)	1 C
VR05	1034250	4.7kΩ (B)	2 C
VR06	1035110		
S01	1110270	Slide Switch	
VC01	1220250	Variable Capacitor	2 A
TC03	1230090	Trimmer Capacitor	
	2410580	Pin Ass'y Type D	
	2410600	Pin Ass'y Type D	
	2410650	Pin Ass'y Type D	

\*Values and Stock No. of most Resistors and Capacitors are shown in Common Parts Lists attached.

### 3-2. F-1511 Power Supply Circuit Board (Stock No. 7501511)

Conductor Side

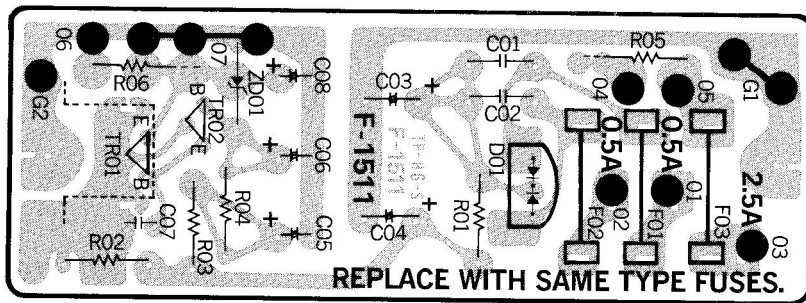

#### Parts List

Parts No.	Stock No.	Description
TR01	0308392, 3	2SD313 (E, F) } Transistor
TR02	0305732, 3	2SC711 (F, G) }
D01	0310680	10DC-1 Diode
ZD01	{0315310 0315980	RD-13A (N) EQA01-14R
C01	0655103	10000 pF 500V C.C.

Parts No.	Stock No.	Description
C02	0655103	10000 pF 500V C.C.
R01	0103100	10Ω ½W C.R.
F01	0430810	0.5A 250V
F02	0430810	0.5A 250V
F03	0430860	2.5A 250V
	2310150	P Type Fuse Holder

\*Values and Stock No. of most Resistors and Capacitors are shown in Common Parts Lists attached.

### 3-3. Figures of Semiconductor

SEMICONDUCTORS	COMPLETE CIRCUIT BOARD	SEMICONDUCTORS	COMPLETE CIRCUIT BOARD	SEMICONDUCTORS	COMPLETE CIRCUIT BOARD
	F-2590	2SD313	F-1511	1N60	F-2590
	F-2590	2SC735	F-2590	10DC1	F-1511
2SA726 2SC711 2SC738	F-1511 F-2590	HA-1151	F-2590	VD1212	F-2590
3SK41	F-2590	HA-1196	F-2590	EQB01-14 RD13A-N	F-1511

#### Abbreviations

- C.R.** : Carbon Resistor
- S.R.** : Solid Resistor
- Ce.R.** : Cement Resistor
- M.R.** : Metallized Film Resistor
- M.C.** : Mylar Capacitor
- E.C.** : Electrolytic Capacitor
- BP.E.C.** : Bi-Polar Electrolytic Capacitor
- C.C.** : Ceramic Capacitor
- Mi.C.** : Mica Capacitor
- O.C.** : Oil Capacitor
- P.C.** : Polystyrene Capacitor
- E.C.** : Tantalum Capacitor

# 4. OTHER PARTS

<Front Side>

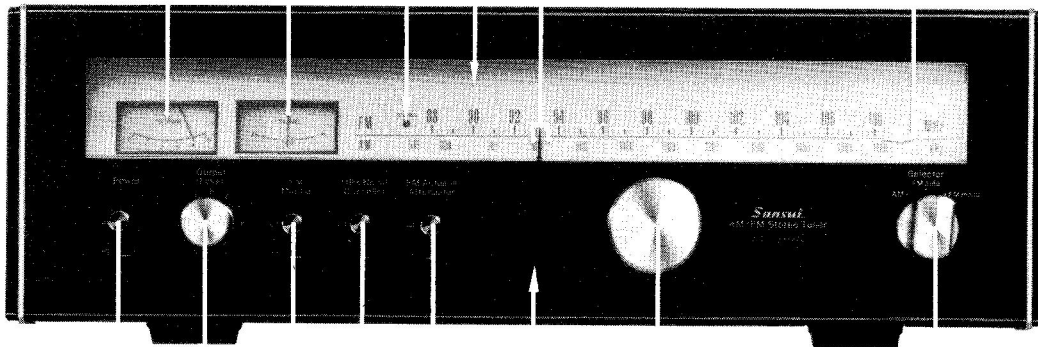

<Back Side>

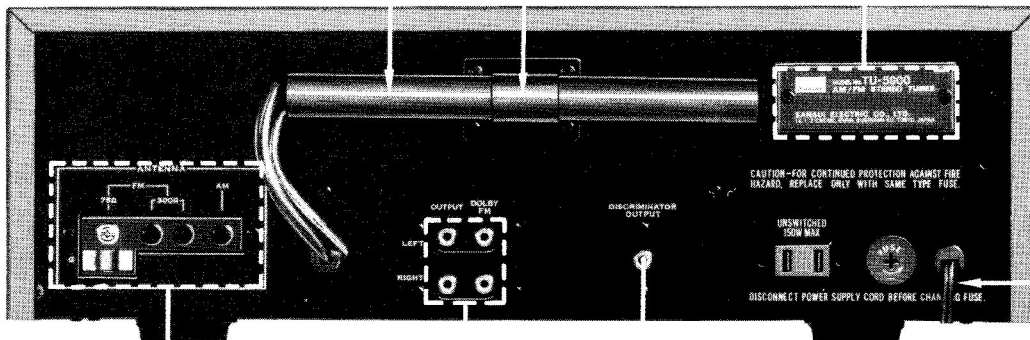

## Parts List

Parts No.	Stock No.	Description
1	1170330	Power Switch
	5326520	Knob, Power Switch
2	1102681	Selector Switch
	5318650	E-11 Type Knob, Selector Switch
3	1011050, 1	Level Volume, 5kΩB
	5318640	S-12 Type Knob, Level Volume
4	7036470	Tuning Unit Ass'y
	5318680	Z-6 Type Knob, Tuning Unit Ass'y
5	1170390	Muting Switch
	5326520	Knob, Muting Switch
6	4300960	Signal Meter
7	4300970	Tune Meter
8	1170390	FM Antenna Att. Switch
	5326520	Knob, FM Antenna Att. Switch
9	1170390	Noise Canceller Switch
	5326520	Knob, Noise Canceller Switch
10	0319090	FM stereo Indicator, LED701
11	5446270	Dial Glass
12	5408020	Dial Scale

Parts No.	Stock No.	Description
13	5416420	Dial Pointer
14	5304460	Side Panel L
15	5304450	Side Panel R
16	5058212	Bottom Plate
17	5516940	Leg
18	7007260	Front Panel Ass'y
19	5006560	Bonnet
	5506970	Bonnet Packing
20	4200820	Bar Antenna, L702
21	5266442	Bar Antenna Holder
	5287280	Bar Antenna Holder Case
22	2210190	Antenna Terminal
23	2200320	4P Input Terminal
24	2200290	1P Input Terminal
25	3800261, 2	Power Cord
26	2410081	Voltage Selector, Socket
	2410091	Voltage Selector, Plug
	5287270	Voltage Selector, Cover

Other Parts

<Top Side>

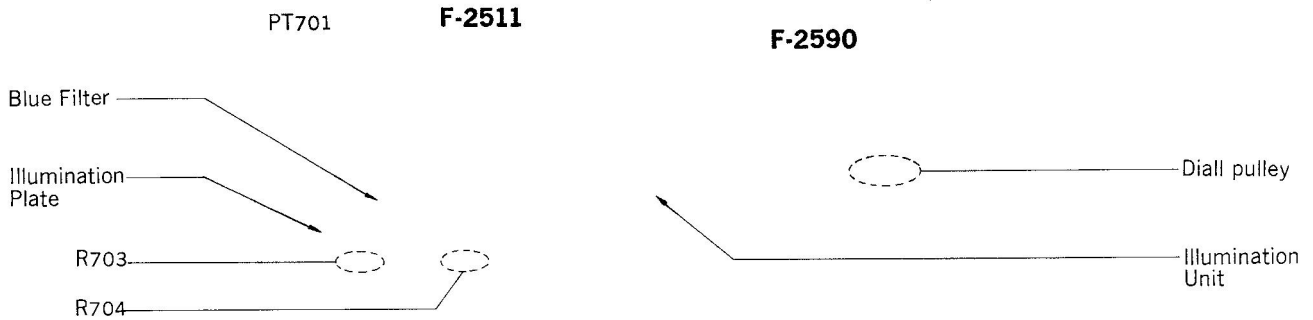

<Bottom Side>

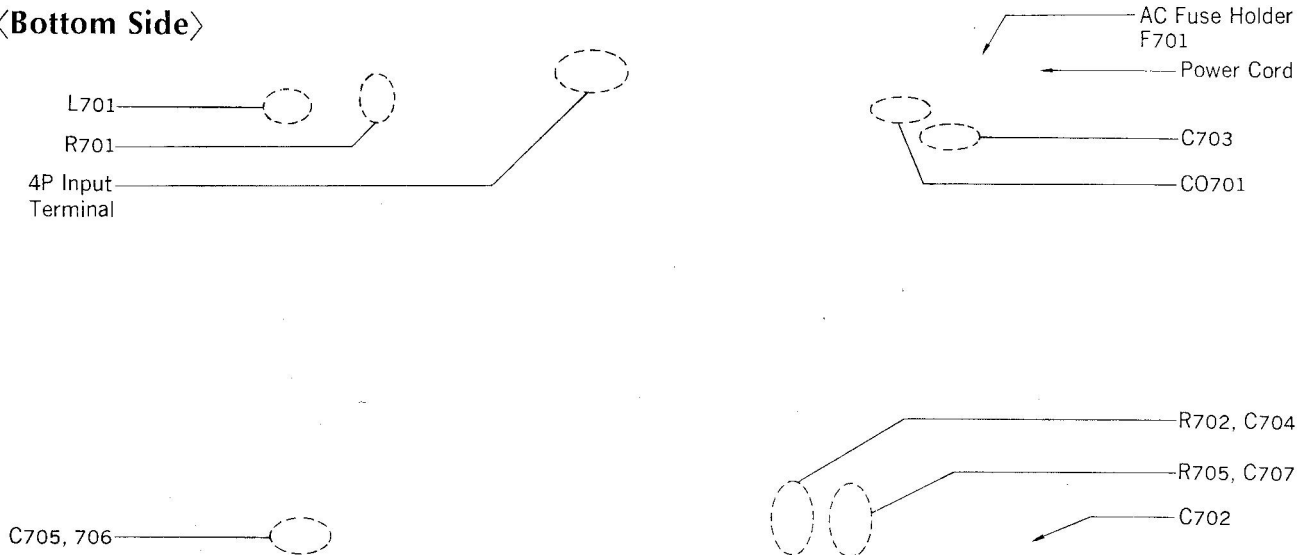

Parts List

Parts No.	Stock No.	Description
	5388630	Name Plate
	5037520	Blue Filter
	5446260	Illumination Plate
	7726160	Illumination Unit (Circuit Board) (Pilot Lamp)
	6146710	D44, Dial Pulley
C702	0659801	0.01 $\mu$ F 1.4kV C.C.
C703	0659802	0.0047 $\mu$ F 150V C.C.
C704	0600157	0.015 $\mu$ F 50V M.C.
C705	0515339	3.3 $\mu$ F 50V E.C.
C706	0515339	3.3 $\mu$ F 50V E.C.
C707	0513479	4.7 $\mu$ F 25V E.C.

Parts No.	Stock No.	Description
R701	0103122	1.2k $\Omega$ $\frac{1}{2}$ W C.R.
R702	0113681	680 $\Omega$ $\frac{1}{4}$ W S.R.
R703	0193220	22 $\Omega$ $\frac{1}{4}$ W Fuse Resistor
R704	0193220	22 $\Omega$ $\frac{1}{4}$ W Fuse Resistor
L701	4290021	FM Antenna Transformer
PT701	4002380	Power Transformer
	2300060	AC Fuse Holder
F701	{0431210 0431220}	{0.5A (AC 220~240V) 1A (AC 100~120V)} Power Fuse
CO701	2450060	AC Outlet

## 5. TROUBLESHOOTING CHART

Symptom	Defective circuit or checkpoint	Cause
1. Both AM and FM inoperative	1) Power supply section inoperative	1. Defective power fuse, F701 opens 2. F01, F02 on F-1511 opens 3. Defective TR01, TR02 on F-1511
2. AM inoperative	1) Defective semiconductors	1. Defective TR12 on F-2590 2. Defective TR13 on F-2590 3. Defective IC03 on F-2590
3. AM poor sensitivity	1) Incorrect adjustment	1. IF or Tracking out of adjustment 2. IF Coil, CF04 out of adjustment
4. Signal meter does not properly operate	1) Defective meter circuit	1. Signal meter volume out of adjustment
5. FM inoperative	1) Defective FRONT-END pack 2) Defective IF section	1. Defective FET01, TR01, TR02 on F-2590 2. RF coil or OSC coil opens 1. Defective TR03, TR04 on F-2590 2. Defective IF IC, HA1137W 3. IF coil, T01 opens 4. 10.7MHz coil, T02, T03 opens
6. FM poor sensitivity	1) Incorrect adjustment 2) Poor FM input signal	1. IF or Tracking out of adjustment 2. 10.7MHz coil on IC01 out of adjustment 1. Weak electric field intensity area 2. Defective Antenna
7. Signal meter does not properly operate	1) Defective meter circuit	1. Poor Sensitivity 2. Defective IC01 on F-2590 3. Signal meter volume out of adjustment
8. MPX inoperative	1) Defective PLL circuit 2) Defective semiconductors	1. Defective IC, HA1196 1. TR10, TR11 on muting circuit shorted
9. No channel separation on FM stereo reception	1) Incorrect adjustment	1. Defective IC02, IA-1196 2. Free-run frequency adjustment volume VR05 out of adjustment 3. TR05 on F-2590 shorted 4. Indicator volume, out of adjustment
10. Troubles on Muting, Indicator circuit	1) Muting inoperative 2) Indicator circuit inoperative	1. Defective TR06~TR11 muting and indicator circuit 2. Muting volume out of adjustment 1. Defective LED701

# 7. SCHEMATIC DIAGRAM

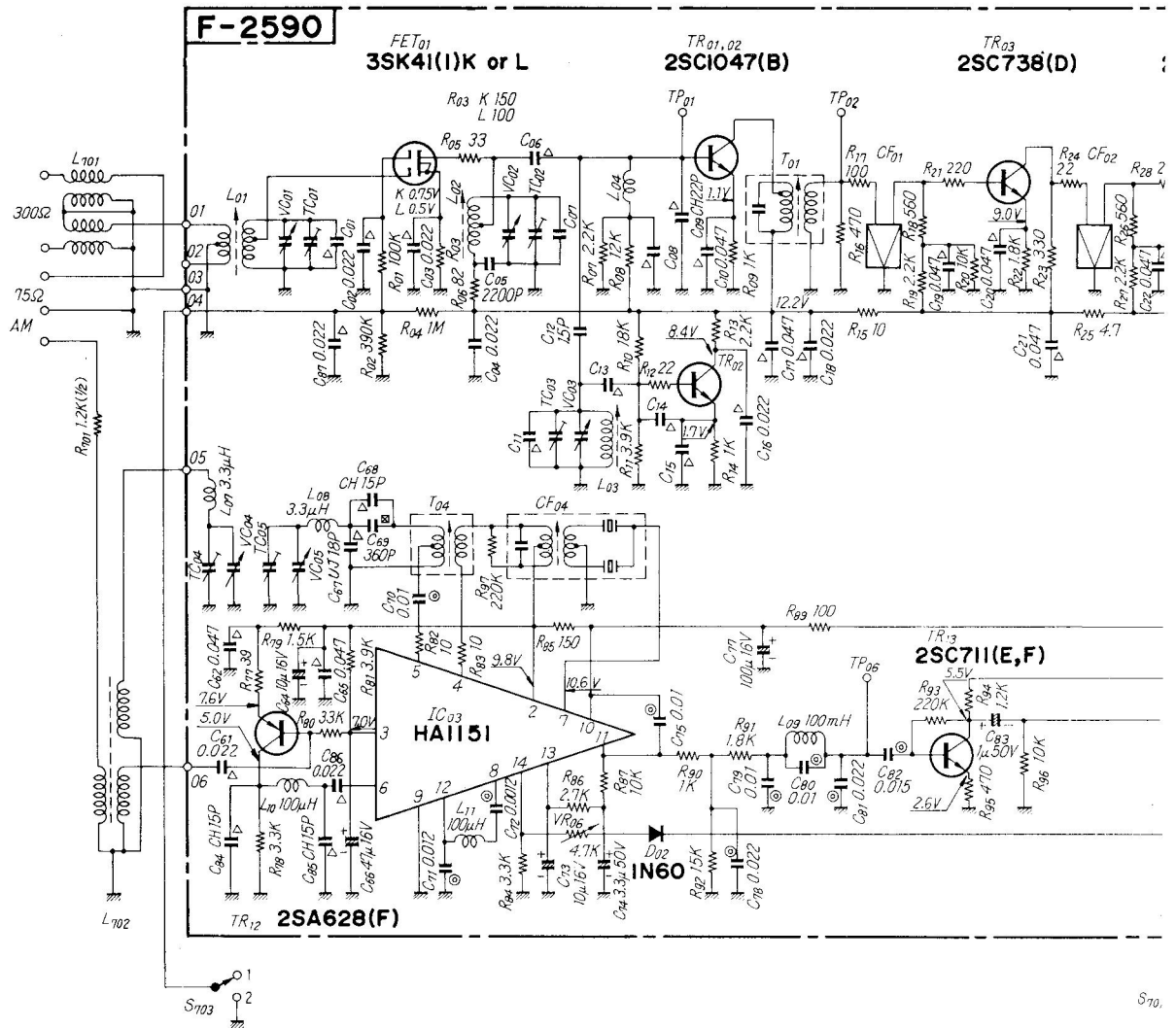

	Export	Japan
C01	SH15PF	SH22PF
C07	SH15PF	SH22PF
C08	1000PF	220PF
C11	SH20PF	TH12PF
C13	CH10PF	SH10PF
C14	CH10PF	SH10PF
C15	CH10PF	SH22PF
C06	CH8.2PF	CH5.6PF

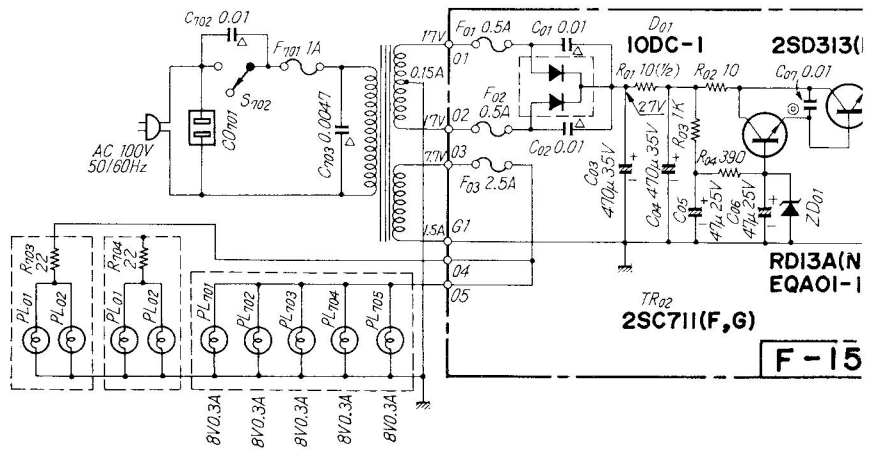

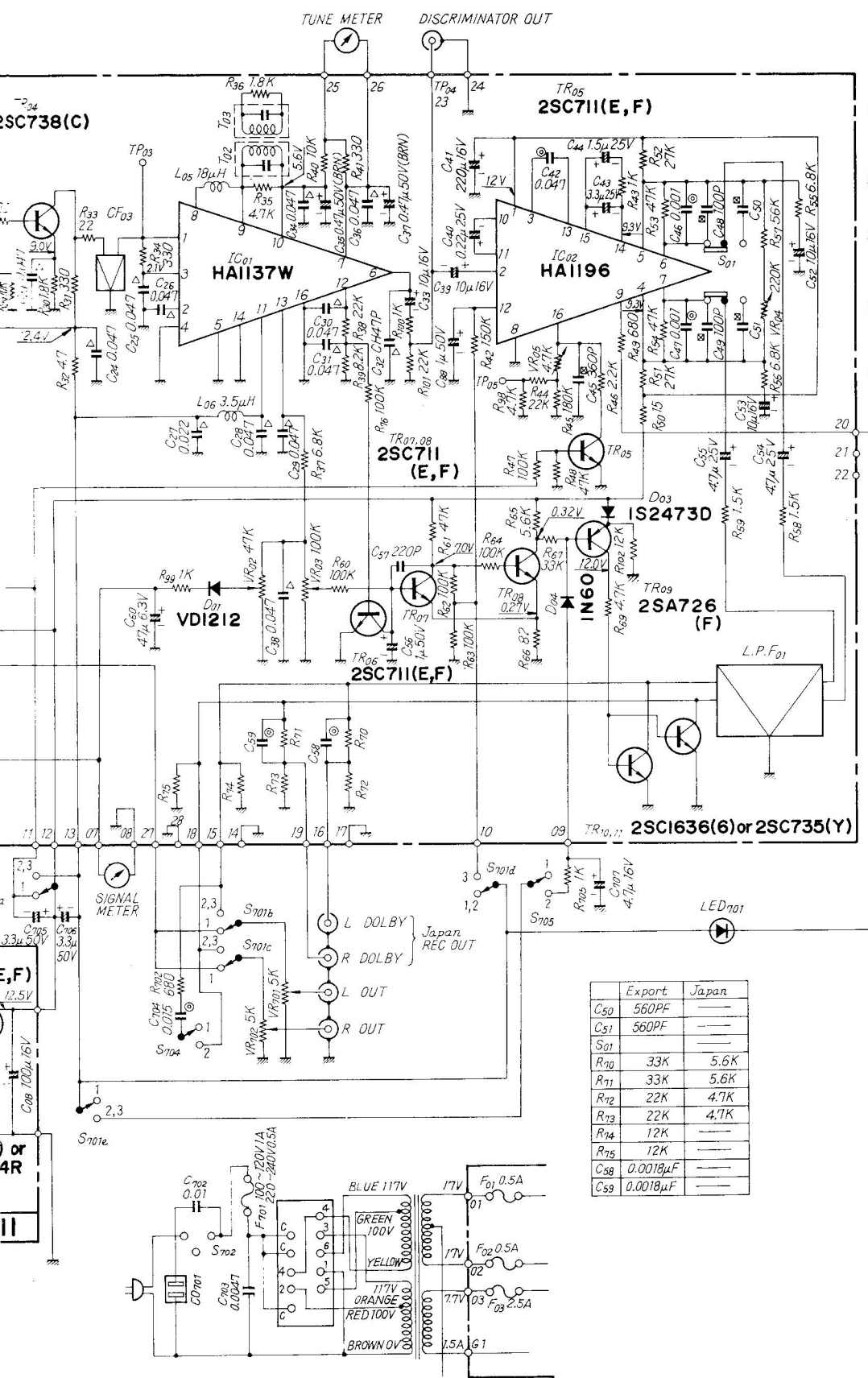

- SWITCHES
- S701 (a-e) SELECTOR
    1. AM
    2. FM AUTO
    3. FM MONO
  - S702 POWER
    1. ON
    2. OFF
  - S703 ANTENNA ATT. SW
    1. OUT
    2. IN
  - S704 NOISE CANCELLER SW
    1. OUT
    2. IN
  - S705 MUTING SW
    1. ON
    2. OFF

SYMBOL

- △ Ceramic
- ▴ Styrol
- ⊙ Mylar

RESISTOR  
All Resistors 1/4 Watts  
Unless Otherwise Noted.

	Export	Japan
C50	560PF	—
C51	560PF	—
S01	—	—
R10	33K	5.6K
R11	33K	5.6K
R12	22K	4.7K
R13	22K	4.7K
R14	12K	—
R15	12K	—
C58	0.0018μF	—
C59	0.0018μF	—

\* La présentation et les spécifications sont susceptibles d'être modifiées sans préavis par suite d'améliorations éventuelles.  
 \* Änderungen, die dem technischen Fortschritt dienen, bleiben vorbehalten.  
 \* Design and specification subject to change without notice for improvements.



## 8. THREADING OF DIAL CORD

\*If a dial cord is cut off or slips, replace it by following procedures.

As this unit uses 0.6mm $\phi$  cord, please replace it with the same type certainly.

\*The length of dial cord is approximately 160cm (65.3 inch).

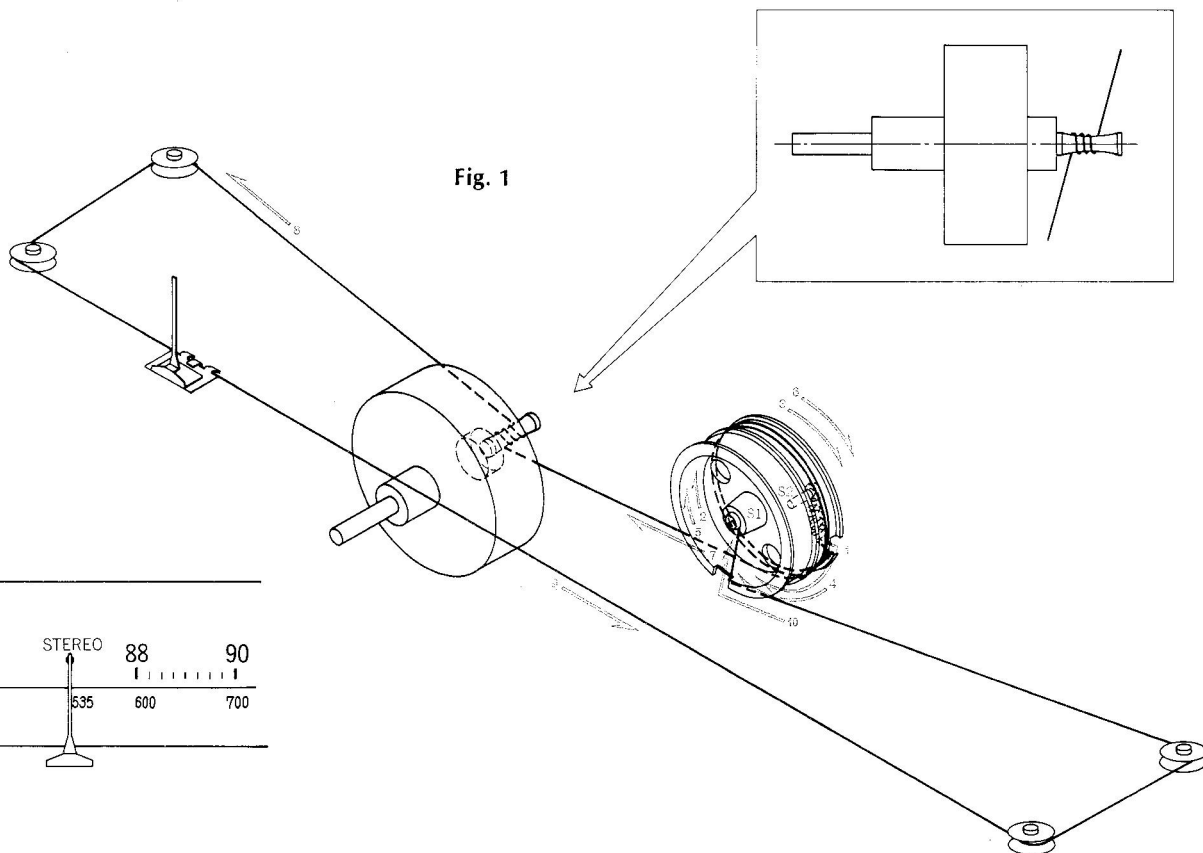

Fig. 1

Fig. 2

### 1. Threading of Dial Cord

Thread the dial cord in numerical order from ① to ⑩ as Fig. 1.

- 1) Close the variable capacitor completely (Max. capacitance).
- 2) Tie dial cord to the dial spring as Fig. 1.
- 3) Thread cord in the direction of arrow from ① to ⑩.
- 4) After ⑩, tie the cord to the screw S1 of the dial pulley.

### 2. Attachment of Dial Pointer

- 1) Close the variable capacitor completely.
- 2) Set the dial pointer to the Stereo Indicator on dial scale as Fig. 2.

\*Confirm that the dial pointer runs smoothly on the dial scale by turning the tuning shaft.

### Parts List

Stock No.	Description
6036050	Dial Cord (0.6mm $\phi$ )
6146710	D44 Type Pulley (with spring)

## 9. PACKING LIST

Parts No.	Stock No.	Description
1	9116640	Vinyl Cover
2	9027791	Stylofoam Packing
3	9009100	Carton Case
4	5996080	Curl Stopper

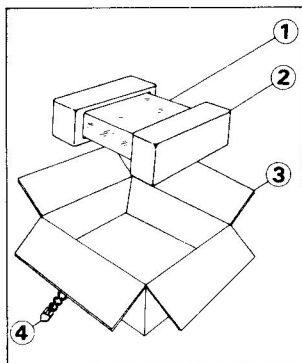

## 10. ACCESSORY PARTS LIST

Stock No.	Description
9209550	Operating Instructions
3810180, 1	Pinplug Cord
3820090, 1	FM Antenna
9237310	Schematic Diagram



SANSUI ELECTRIC CO., LTD.  
14-1, 2-chome, Izumi, Suginamiku, Tokyo 168, Japan.  
TELEPHONE: (03) 323-1111 / TELEX: 232-2076