

SERVICE MANUAL

AM/FM STEREO TUNER SANSUI TU-717



Original

SPECIFICATION

FM Section

Tuning range	88 to 108 MHz
Usable Sensitivity	
MONO IHF	10.6 dB (1.85 μ V: T100)
Stereo IHF	19.0 dB (4.9 μ V)
50 dB Quieting Sensitivity	
Mono	13 dB (2.45 μ V)
Stereo	37.2 dB (40 μ V)
Signal to noise ratio at 65 dBf	
Mono	80 dB
Stereo	77 dB
Distortion (at 65 dBf)	
Mono: Wide	less than 0.13% at 100 Hz less than 0.07% at 1,000 Hz less than 0.15% at 6,000 Hz
Narrow	less than 0.18% at 100 Hz less than 0.15% at 1,000 Hz less than 0.2% at 6,000 Hz
Stereo: Wide	less than 0.13% at 100 Hz less than 0.07% at 1,000 Hz less than 0.15% at 6,000 Hz
Narrow	less than 0.22% at 100 Hz less than 0.2% at 1,000 Hz less than 0.25% at 6,000 Hz

Adjacent channel selectivity (at 200 kHz)

Wide	3.5 dB
Narrow	8.0 dB

Alternate channel selectivity (at 400 kHz)

Wide	50 dB
Narrow	80 dB

Capture ratio

Wide	1.2 dB
Narrow	1.7 dB

Image response ratio

86 dB (at 98 MHz)

Spurious response ratio

90 dB (at 98 MHz)

Stereo separation

Wide	41 dB at 100 Hz 45 dB at 1,000 Hz 38 dB at 10,000 Hz 36 dB at 30 ~ 15,000 Hz
------	---

Frequency response

30 to 15,000 Hz +1 dB -2 dB

Antenna input impedance

	300 ohms balanced
	75 ohms unbalanced

AM Section

Tuning range	530 to 1,600 kHz
Usable sensitivity	
(Bar antenna)	50 dB/m (300 μ V/m)
Selectivity (\pm 10 kHz)	
	35 dB
Signal to noise ratio	50 dB

Others

Output level	
Output	0 to 1V
Power requirements	100, 120, 220, 240V 50/60 Hz 120V (Usable 110 - 130V) (For U.S.A. & Canada only)
Power consumption	20W
Weight	9.2 kg (20.3 lbs) net 11.0 kg (24.3 lbs) packed

* Design and specifications subject to change without notice for improvements.

SANSUI ELECTRIC CO., LTD.

1. BLOCK DIAGRAM

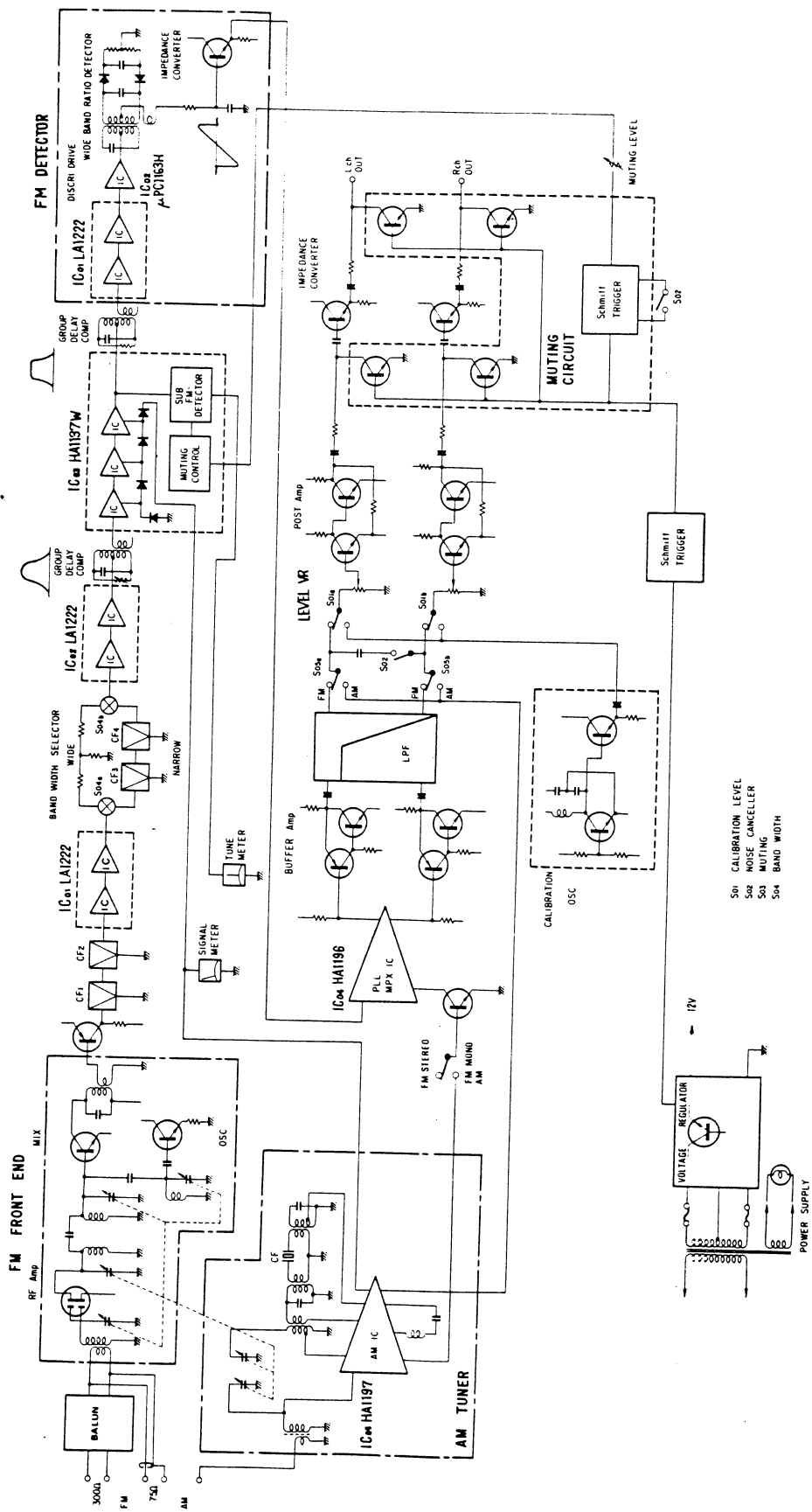

3. ADJUSTMENT

3-1. FM Adjnstment

- Note: 1. Selector FM AUTO
 2. FM Muting Switch OFF
 3. Connection.... Connect the output of genescoppe to TP through 100pF ceramic capacitor.

4. Confirm the voltage, DC 11.5~12.5V at tap of 08 on F-2681
 If not, set VR01 on F-2681 to DC 12V.

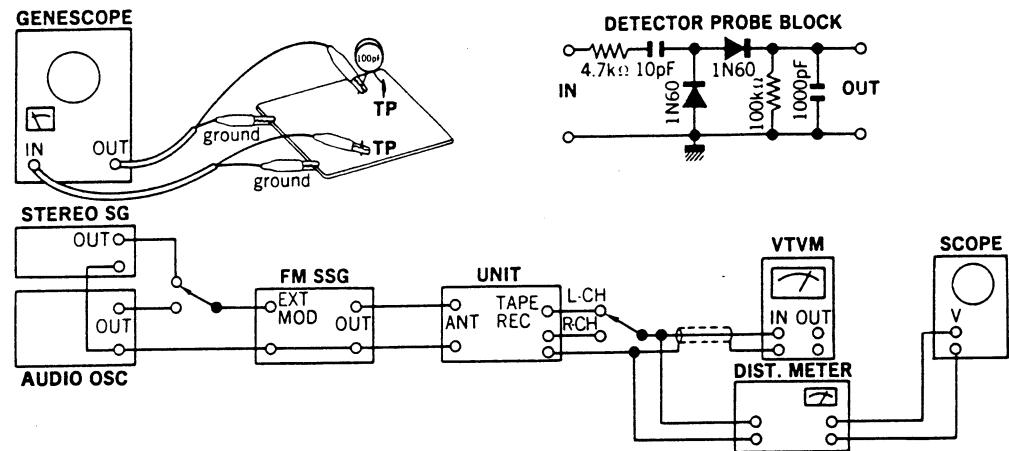

1) FM IF, RF Adjustment and Dial Calibration

STEP	SUBJECT	FEED SIGNAL		MEASURE OUTPUT	ADJUST	ADJUST FOR	CONDITION
		FROM	TO				
1.	IF Coil	Output 60dB Genescoppe	TP01 F-2678	TP04 F-2678 Use Detector Probe	T01, T02 F-2678	Max. IF waveform	
2.	Discriminator Coil	Same as above	Same as above	TP01 F-2730	T01 F-2730 T02 F-2730	Steep linearity of S curve Make symmetrical S curve	
3.	90MHz Dial Calibration	90MHz ANT Input 65dBf (59.8dB) 1000Hz (100% MOD) FM SSG	ANT terminal 300Ω	OUT L or R-CH VTVM & Scope	L04 F-2678	Max. Output	
	106MHz Dial Calibration	106MHz ANT Input 65dBf (59.8dB) 1000Hz (100% MOD) FM SSG	Same as above	Same as above	TC04 F-2678	Same as above	
4.	90MHz RF Adj.	90MHz ANT Input Minimum valve with sine wave 1000Hz (100% MOD) FM SSG	Same as above	Same as above	L01, L02, L03 F-2678	Same as above	
	106MHz RF Adj.	106MHz ANT Input Minimum valve with sine wave 1000Hz (100% MOD) FM SSG	Same as above	Same as above	TC01, TC02, TC03 F-2678	Same as above	
5.	Signal Meter Volume	98MHz ANT Input 65dBf (59.8dB) 1000Hz (100% MOD) FM SSG	Same as above	Signal Meter	VR02 F-2678	4.3 on Meter	
6.	Tune Meter	Same as above	Same as above	Tune Meter	T03 F-2678	Center on Meter	

2) FM STEREO Adjustment

STEP	SUBJECT	FEED SIGNAL		MEASURE OUTPUT	ADJUST	ADJUST FOR	CONDITION
		FROM	TO				
1.	PLL VCO Adj.	98MHz ANT Input 65dBf (59.8dB) FM SSG Pilot 19kHz (9% MOD) SUB 1kHz+Pilot (100% MOD) STEREO SG	ANT terminal 300Ω	Stereo indicator	VR04 F-2678	Light indicator	Adjust the VR within center of lighting level.
	PLL VCO Adj. In case of using Freq. counter.	Same as above	Same as above	TP06 F-2678 Use Freq. counter	VR04 F-2678	76kHz ±200Hz	Make short between 23 Pin (F-2678) & chassis
2.	Separation	98MHz ANT Input 65dBf (59.8dB) FM SSG Pilot 19kHz (9% MOD) R (or L) Mode 1kHz+ Pilot (100% MOD) STEREO SG	Same as above	OUT L (or R)-CH VTVM & Scope	VR02 F-2680	OUT -45dB	Confirm separation L-CH→R-CH
3.	Muting level & indicator level	98MHz ANT Input 18dBf (12.8dB) FM SSG Pilot 19kHz (9% MOD) SUB 1kHz+Pilot (100% MOD) STEREO SG	Same as above	Stereo indicator	VR03 F-2678	Muting level 18dBf (12.8dB) Indicator lighting level 18dBf (12.8dB)	FM MUTING Switch ON

3) Calibration level Adjustment

STEP	SUBJECT	FEED SIGNAL		MEASURE OUTPUT	ADJUST	ADJUST FOR	CONDITION
		FROM	TO				
1.	Calibration level Adj.	98MHz ANT Input 65dBf (59.8dB) MONO 1000Hz (100% MOD)	ANT Terminal 300Ω	OUT R or L-CH VTVM & Scope		Set Indication level of VTVM to 0dB	Calibration Switch.....Out
				Same as above	VR01 F-2679	Set the Indication level to -3dB from the above 0dB	Calibration Switch.....In

※ NEW MEASUREMENT FOR FM.

Input signal level under the provision of IHFM-T-200, a new measurement method is indicated by available power ratio "dBf". To obtain approximate available power ratio "dBf", abstract 0.8 from attenuator indication of general FMSSG (open load indication type); however, the former measurement, IHFM-T-100 is designated together too. The way of modulation on IHFM-T-200 is shown below.

	modulation frequency	modulation mode	modulation factor
FM MONO	1000Hz		100%
FM STEREO	1000Hz	SUB	Pilot 9% Pilot+SUB 100%

※The relation between the standard input 65dBf of IHFM-T-200 and the former indication "dB" is shown below.

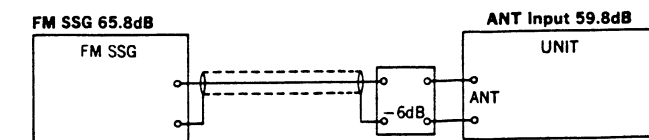

3-2 AM IF Adjustment & Dial Calibration

Note: 1. Selector.....AM

2. Confirm start point of dial pointer before alignment.

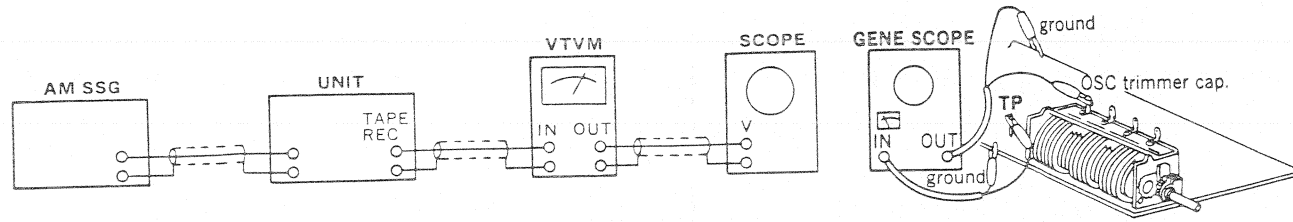

STEP	SUBJECT	FEED SIGNAL		MEASURE OUTPUT	ADJUST	ADJUST FOR	CONDITION
		FROM	TO				
1.	IF Coil	Genescope Output 70dB	TC06 F-2678	TP07 F-2678	CF05 LC02 F-2678	Max. IF waveform	
2.	600kHz Dial Calibration	600kHz ANT Input 60dB 400Hz (MOD 30%) AM SSG	AM ANT terminal	OUT L or R-CH VTVM & Scope	T04 F-2678	Max. Output	
	1400kHz Dial Calibration	1400kHz AN Input 60dB 400Hz (MOD 30%) AM SSG	Same as above	Same as above	TC06 F-2678	Same as above	
3.	600kHz RF Adj.	600kHz ANT Input 50dB 400Hz (MOD 30%) AM SSG	Same as above	Same as above	Bar Antenna L702	Same as above	
	1400kHz RF Adj.	1400kHz ANT Input 50dB 400Hz (MOD 30%) AM SSG	Same as above	Same as above	TC05 F-2678	Same as above	
4.	Signal Meter volume	1000kHz ANT Input 80dB 400Hz (MOD 30%) AM SSG	Same as above	Signal Meter	VR05 F-2678	4.3 on meter	
		460kHz Trap	460kHz ANT Input 80dB 400Hz (MOD 30%) AM SSG	OUT L or R-CH VTVM & Scope	L13 LC01 F-2678	Min. Output	

Abbreviations

Equipment

- AM FM Generator Oscilloscope..... Genescope
- AM Standard Signal GeneratorAM SSG
- FM Standard Signal GeneratorFM SSG
- FM Stereo Generator.....Stereo SG
- OscilloscopeScope
- Audio OscillatorAudio Osc.
- Distortion MeterDist. Meter

Others

- ClockwiseCW.
- CounterclockwiseCCW.
- AntennaANT.
- ModulationMOD.

4. PARTS LOCATION & PARTS LISTS

4-1. F-2678 Tuner Circuit Board (Stock No. 7521451)

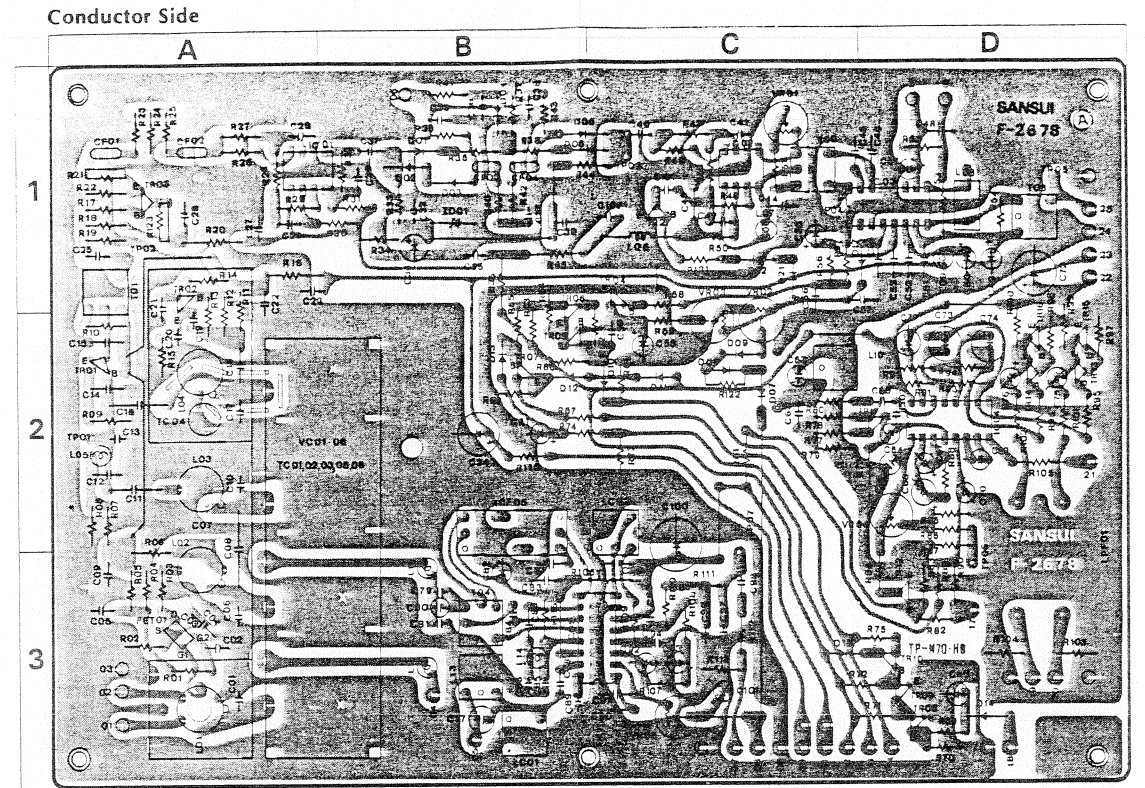

Parts List

Parts No.	Stock No.	Description	Position	Parts No.	Stock No.	Description	Position	Parts No.	Stock No.	Description	Position
TR01	0305801.2	2SC1047 (B,C)	2A	D17	0340120	VD1212 Varistor		L06	4290011	3.5μH Peaking Coil	1C
TR02	0305801.2	2SC1047 (B,C)	2A	D21	0311160	1S2473D Diode		L07	4900100	3.3μH	1C
TR03	0300282.3	2SA428 (E,F)	1A	D22	0340120	VD1212 Varistor		L08	4290300	18μH	1D
TR04	0305731.2	2SC711 (E,F)	2C	ZD01	{0315560 RD-6A* 0315770 EQA01-065}	Zener Diode	1B	L09	4900100	3.3μH Inductor	1D
TR05	0305731.2	2SC711 (E,F)	2B	C01	0669350	15pF	3A	L11	4900140	1μH	3B
TR06	0305731.2	2SC711 (E,F)	2B	C04	0669015	2200pF	3A	L12	4900140	1μH	3B
TR07	0300510.1	2SA733 (P,Q)	3D	C06	0669350	15pF	3A	L13	4290250	21μH	3B
TR08	0305731.2	2SC711 (E,F)	3D	C07	0669015	2200pF	2A	L14	4290110	100μH	3B
TR09	0305731.2	2SC711 (E,F)	3D	C08	0679024	0.33pF 500V Glimick Capacitor	2,3A	T01	4235920	FM IF Coil	1,2A
TR10	0300510.1	2SA733 (P,Q)	2D	C10	0669350	15pF	2A	T02	4235930	FM IF Coil	1C
TR12	0305731.2	2SC711 (E,F)	2D	C11	0669507	7pF	2A	T03	4235860	FM IF Coil	1D
TR13	0300510.1	2SA733 (P,Q)	2D	C16	0679008	1pF 500V Glimick Capacitor	2A	T04	4220650	AM OSC Coil	
TR14	0300510.1	2SA733 (P,Q)	2D	C17	0669355	20pF	2A	CF01	0910380	Ceramic Filter	1A
TR15	0306010.1	2SC1222(2)(U,E)	2D	C18	0669210	10pF	2A	CF02	0910380	Ceramic Filter	1A
TR16	0306010.1	2SC1222(2)(U,E)	2D	C19	0669210	10pF 50V C.C.	2A	CF03	0910380	Ceramic Filter	1B
TR21	0306342	2SC1674 (K)		C20	0669210	10pF	2A	CF04	0910380	Ceramic Filter	1B
IC04	0360320	HA1196	2D'	C27	0661150	15pF	1B	CF05	0910370	Low Pass Filter	2,3B
IC05	0360390	HA1197	3B, C	C44	0620361	360pF 50V P.C.	2D	LC01	4230620	IF Coil	3B
FT01	0370131	3SK4111 (L) FET		C46	0620361	360pF 50V P.C.		LC02	4230620	IF Coil	2,3C
D01	0311160	1S2473D	1B	C47	0573159	0.22μF 35V		LF01	0910210	Low Pass Filter	
D02	0310330.1	1N60	1B	C49	0573228	0.22μF 35WV T.C.	2D	VR01	1035120	6.8kΩ (B) Group Delay VR	1C
D03	0310330.1	1N60	1B	C77	0620562	5600pF 50V P.C.	3B	VR02	1035170	47kΩ (B) FM Signal Meter VR	2C
D04	0311160	1S2473D	1B	C79	0661150	15pF 50V C.C.	3B	VR03	1035190	100kΩ (B) FM Stereo and Muting Indicator VR	2C
D05	0311160	1S2473D	1B, C	C80	0620361	360pF 50V P.C.	3B	VR04	1034250	4.7kΩ (B) V.C.O. VR	2D
D06	0310330.1	1N60	1B, C	C81	0669400	15pF	3B	VR05	1035110	4.7kΩ (B) AM Signal Meter VR	3C
D07	0311160	1S2473D	2C	C85	0661150	15pF	3B	VC01	1220260	AM FM Variable Capacitor	
D09	0340120	VD1212 Varistor	2C	C86	0661150	15pF	3B	IC01	0360510	LA-1222	1A, B
D10	0311160	1S2473D	2C	C115	0661150	15pF		IC02	0360510	LA-1222	1C
D11	0311160	1S2473D	2C	L01	4200720	Antenna Coil	3A	IC03	0360350	HA1137W	1C, D
D12	0311160	1S2473D	2B	L02	4210340	RF Coil	3A	TC04	1230090	Trimmer Capacitor	
D13	0311160	1S2473D	2B	L03	4210340	RF Coil	2A				
D14	0310340	10D1 (1S2226)	3D	L04	4220400	OSC Coil	2A				
D15	0311160	1S2473D	3C	L05	4900140	1μH Inductor	2A				

4-2. F-2703 Indicator Circuit Board (Stock No. 7595251)

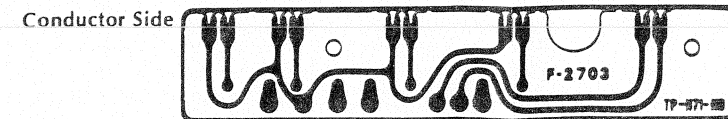

Parts List

Parts No.	Stock No.	Description
LD01	0319060	LED (Red)
LD02	0319050	LED (Green)
LD03	0319060	LED (Red)

4-3. F-2730 FM Discriminator Circuit Board (Stock No. 7521511)

Conductor Side

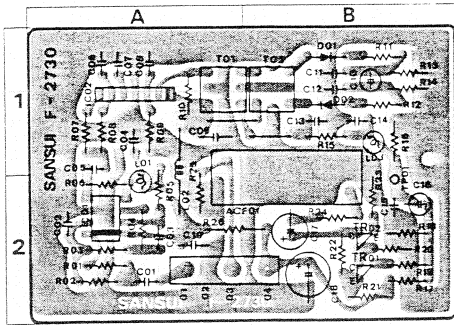

Parts List

Parts No.	Stock No.	Description	Position
TR01	0300510, 1	2SA733 (P, Q)	Transistor 2B
TR02	0306010, 1	2SC1222(2) (U, E)	
IC01	0360510	LA-1222	IC 2A
IC02	0360540	UPC1163H	
D01, 02	0311160	1S2473D	Diode 1B
L01	4900100	3.3μH	Inductor 2A
L02	4290011	3.5μH	
L03	4900110	100μH	
T01	4236010	IF Coil	1A
T02	4236020	IF Coil	1B
F01	0910400	Filter	

4-4. F-2680 Selector SW & Muting Circuit Board (Stock No. 7595241)

Conductor Side

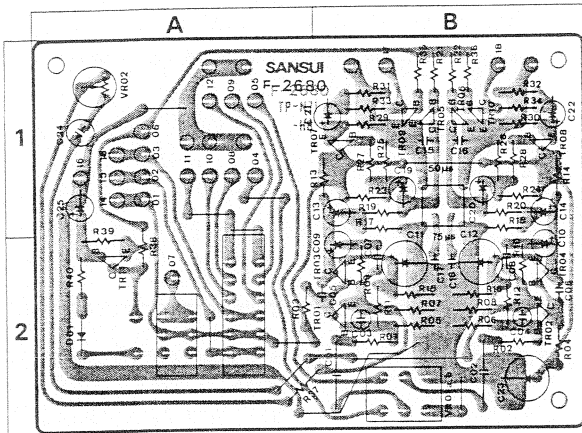

Parts List

Parts No.	Stock No.	Description	Position
TR01, 02	0306010, 1	2SC1222(2) (U, E)	2B
TR03, 04	0306010, 1	2SC1222(2) (U, E)	
TR05, 06	0305952, 3	2SC945 (P, K)	Transistor 1B
TR07, 08	0306010, 1	2SC1222(2) (U, E)	
TR09, 10	0305952, 3	2SC945 (P, K)	1B
TR11	0300510, 1	2SA733 (P, Q)	2A
D01	0311160	1S2473D	Diode 2A
C01, 02	0602109	1.0μF 100VV M.C.	2B
C05, 06	0661150	15pF	50V C.C. 2B
C07, 08	0661180	18pF	
VR01	1015250	50kΩ (B) Level Volume	2B
VR02	1035350	4.7kΩ (B) Separation VR	1A
S05	1131440	Selector Push Switch	
S06	1110270	DE EMPHASIS Switch	

4-5. F-2679 Accessory SW & Calibration Circuit Board (Stock No. 7595231)

Conductor Side

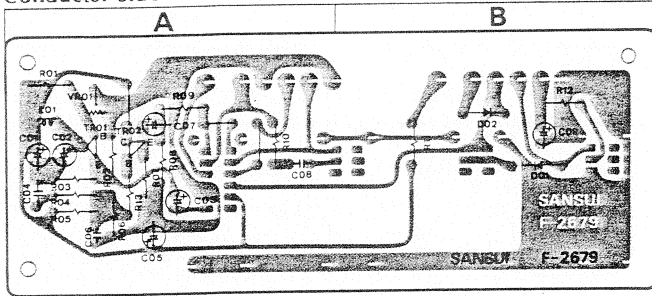

Parts List

Parts No.	Stock No.	Description	Position
TR01	0306011	2SC1222(2) (E)	Transistor
	0306071	2SC1313 (G)	
	0306072	2SC1313 (H)	
	0305951	2SC945 (Q)	
TR02	0305952	2SC945 (P)	Transistor
	0306131	2SC1364 (6)	
	0306132	2SC1364 (7)	
D01	0311160	1S2473D	Diode B
D02	0311160	1S2473D	B
L01	4900220	100mm Inductor	A
VR01	1035170	47kΩ (B) Calibration Level VR	A
S01	1171150	SLA24251 Calibration Level SW	
S02	1171130	SLA22251 Noise Canceller SW	
S03	1171130	SLA22251 Muting SW	
S04	1171130	SLA22251 Band width SW	
	2410700	6P Pin Ass'y Type F	
	2410700	6P Pin Ass'y Type F	

4-6. F-2681 Power Supply Circuit Board (Stock No. 7502401)

Conductor Side

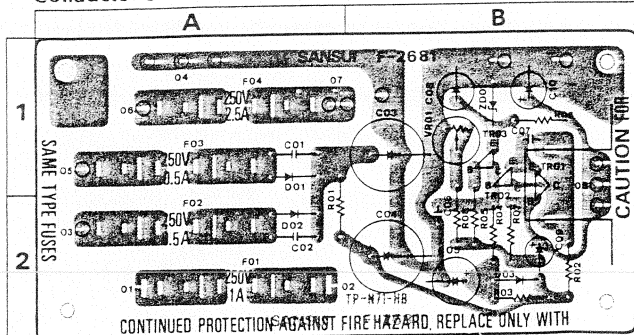

Parts List

Parts No.	Stock No.	Description	Position
TR01	0308391-3	2SD313 (D, E, F)	Transistor 1, 2B
TR02	0305731-3	2SC711 (E, F, G)	
TR03	0305731-3	2SC711 (E, F, G)	
D01, 02	0310340	10D1 (1S2226)	Diode 1, 2A
D03	0310340	10D1 (1S2226)	
ZD01	0315770	EQA01-065 Zener Diode	1B
C01	0655103	10000pF	1A
C02	0655103	10000pF	2A
R01	0103100	10Ω 1/2W C.R.	1, 2A
VR01	1035110	4.7kΩ (B) Voltage Adjusting VR	1B
F02, 03	0431210	0.5A	250V AC Fuse 1, 2A
F04	0431250	2.5A	
	2310220	Fuse Holder	1A

5. OTHER PARTS

5-1. Front View

Parts List

Parts No.	Stock No.	Description	Parts No.	Stock No.	Description	Parts No.	Stock No.	Description
1	5326611	Lever Switch Knob	7	5318900	O-7 Metal Type Knob	16	7007611	Front Panel Ass'y
	1171630	Power Switch		7036510	Tuning Unit Ass'y		5006680	Bonnet
2	5326611	Lever Switch Knob	8	1131410	Selector Push Switch	17	5109246	Binding Head Tapping Screw M4 x 16
	1171130	Band width Switch		5326620	Push Switch Knob		5064320	Bottom Plate
3	5326611	Lever Switch Knob	9	6906480	Spring	18	5109924	Binding Head Tapping Screw M3 x 8
	1171130	Muting Switch		4301070	Signal Meter		5507070	Leg
4	5326611	Lever Switch Knob	10	4301080	Tune Meter	19	5336600	Sansui Badge
	1171130	Noise Canceller Switch		0319060	LED (Red) FM Stereo			
5	5326611	Lever Switch Knob	11	0319050	LED (Green) FM			
	1171150	Calibration Level Switch		0319060	LED (Red) AM			
6	5318850	N-7 Metal Type Knob	12	5408180	Dial Scale			
	1015250	50kΩ(B) Level Volume		5416460	Dial Pointer			

5-2. Top View

Parts List

Parts No.	Stock No.	Description	Parts No.	Stock No.	Description	Parts No.	Stock No.	Description
C701	0659801	0.01μF	2200300	2200300	2P Input terminal	7726130		Illumination Unit Ass'y 8V 0.3A
C702	0659802	0.0047μF		2210310	Antenna terminal	3800010		Power Cord
R701	0103122	1.2kΩ 1/2W C.R.		5136030	Nylon Fastener	3910600		Strain Relief
L701	4290021	75Ω/300Ω FM Balun	5037530	Blue Filter	F701	0432210	0.5A 250V	Power fuse
L702	4200850	Bar Antenna	6146690	Guide Pulley For Dial String	0432220	1A 250V		
	3910510	Strain Relief	7136090	Tension Unit	2300060		Fuse Holder	
PT701	4002430	Power Transformer	5284450	Bar Antenna Holder (2)	2410081		Voltage Selector Socket	
			5284480	Bar Antenna Holder (1)	241009J		Voltage Selector Plug	

Figures

Connectors & Pin Ass'y

Connectors

Type	Stock No.
Type A (3~10 pins)	2 Pins 2420450
Type B (2~6 pins)	3 Pins 2420460
	3 Pins (RED) 2420650
	4 Pins 2420470
	5 Pins 2420480
	6 Pins 2420490

NOTE: Since stock number of female connectors (type B) with wires are not shown in each parts list of Complete circuit board, please refer to the above parts list when ordering the connector.

Pin Ass'y

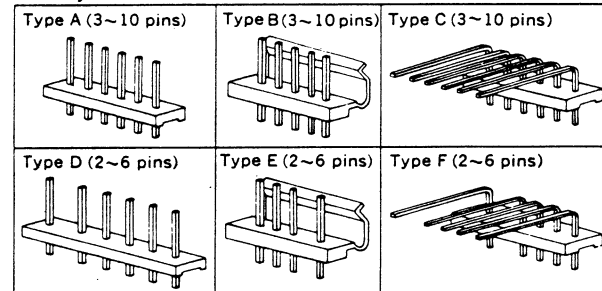

Abbreviations

C.R. : Carbon Resistor	E.C. : Electrolytic Capacitor
S.R. : Solid Resistor	BP.E.C.: Bi-Polar Electrolytic Capacitor
Ce.R. : Cement Resistor	
M.R. : Metal Film Resistor	C.C. : Ceramic Capacitor
F.R. : Fusing Resistor	Mi.C. : Mica Capacitor
N.I.R. : Non-Inflammable Resistor	O.C. : Oil Capacitor
M.C. : Mylar Capacitor	P.C. : Polystyrene Capacitor
	E.C. : Tantalum Capacitor

Front View

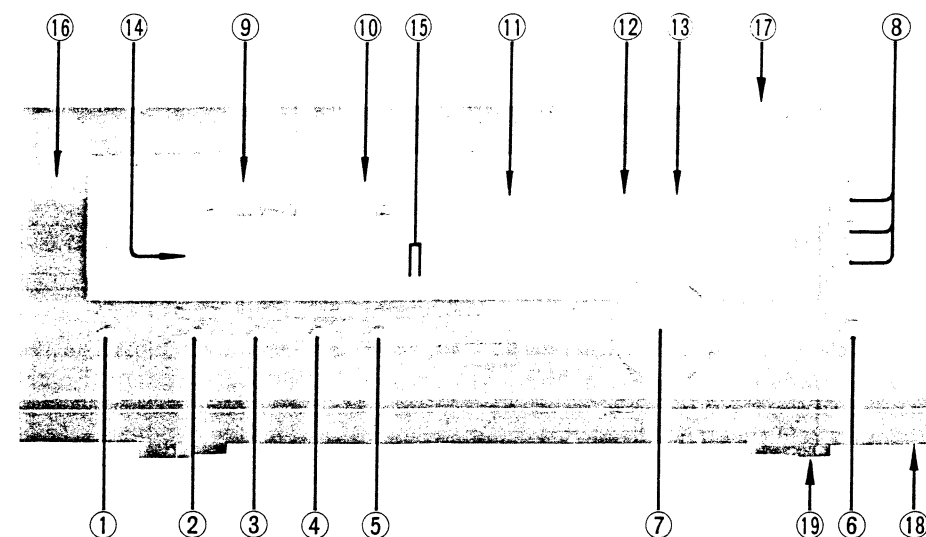

Top View

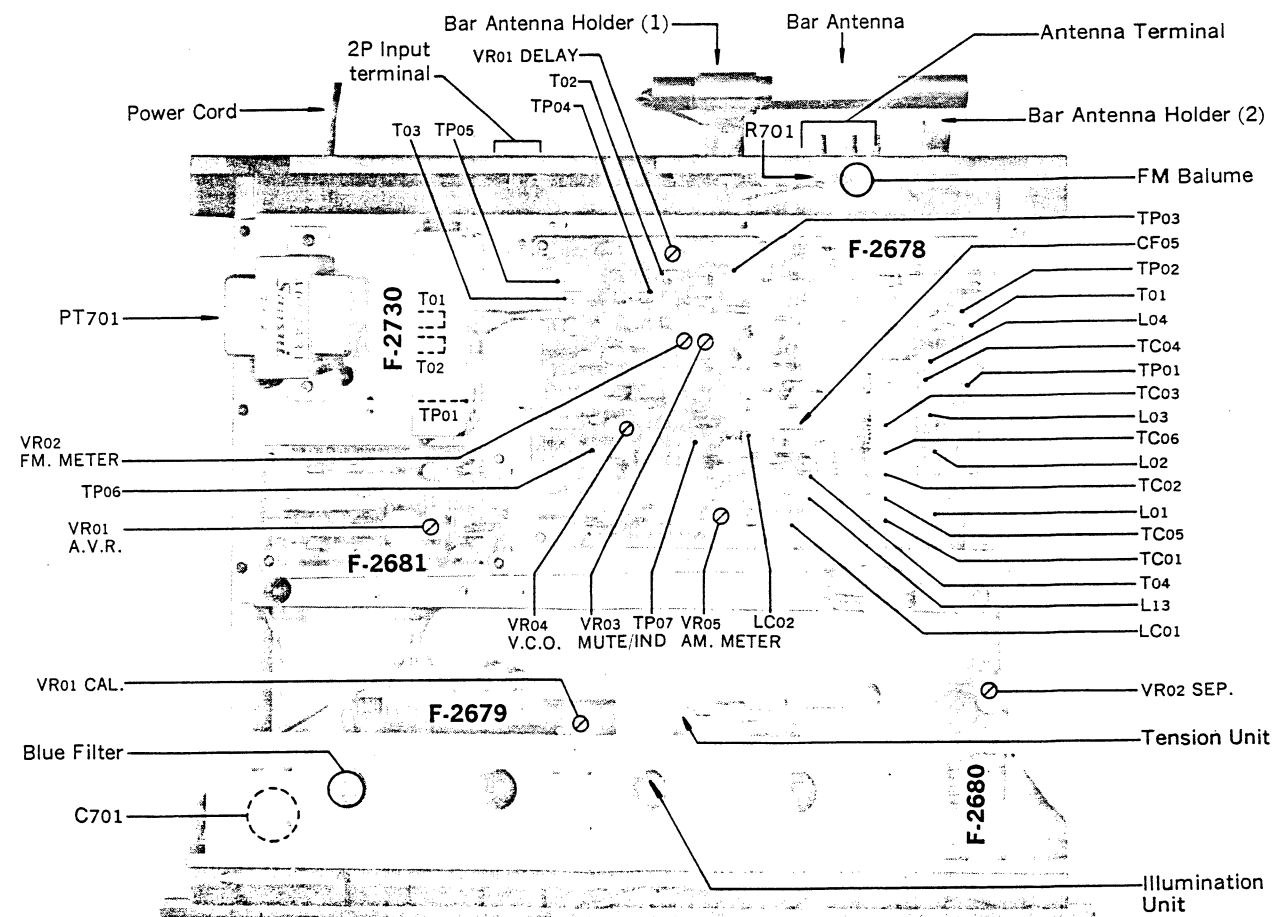

6. SCHEMATIC DIAGRAM

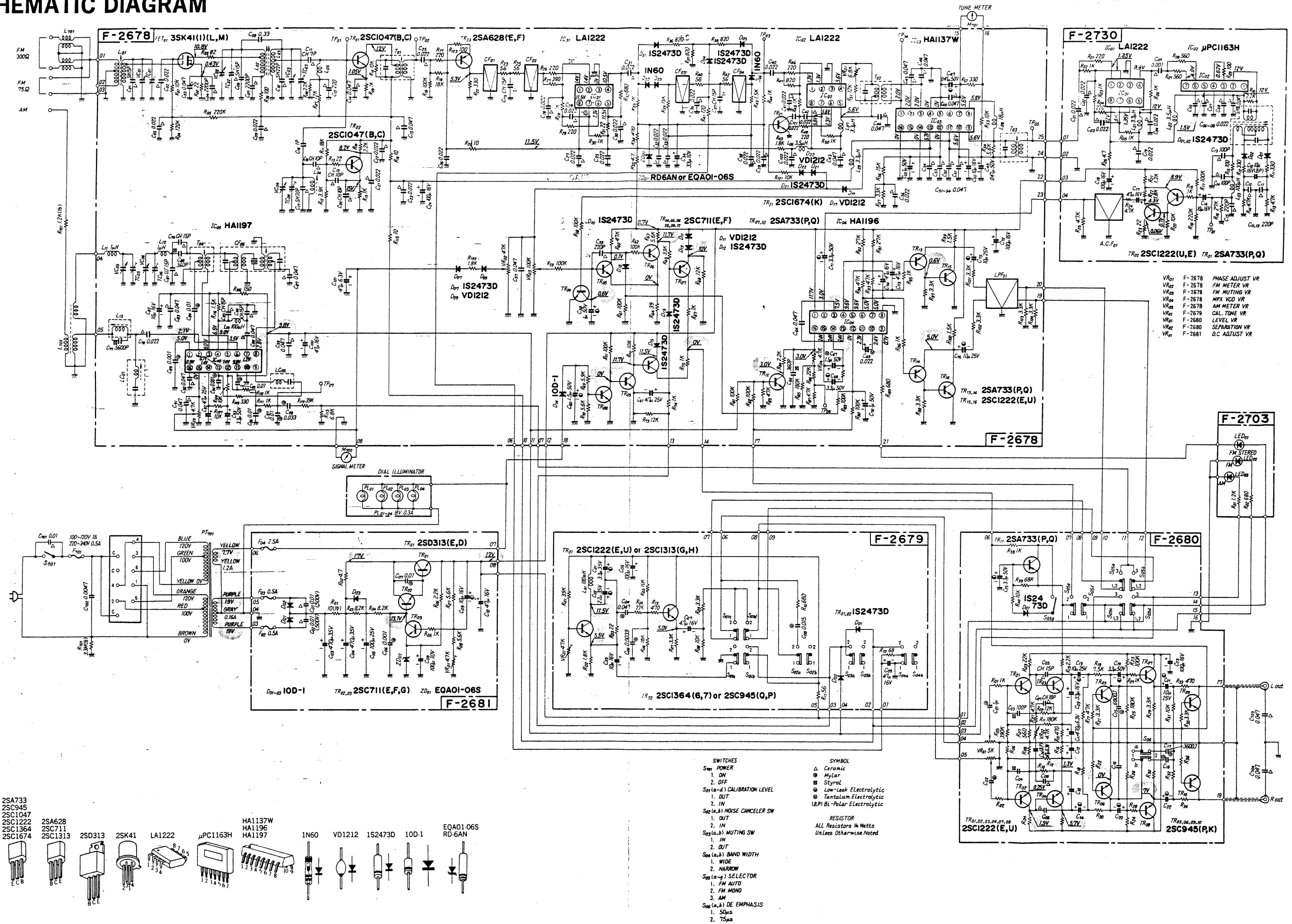

• La présentation et les spécifications sont susceptibles d'être modifiées sans préavis par suites d'améliorations éventuelles.
 • Änderungen, die dem technischen Fortschritt dienen, bleiben vorbehalten.
 • Design and specifications subject to change without notice for improvement.

7. THREADING OF DIAL CORD

*If a dial cord is cut off or slips, replace it by following procedures.

As this unit uses 0.5mmφ cord, please replace it with the same type certainly.

*The length of dial cord is approximately 170cm (66.9 inch),

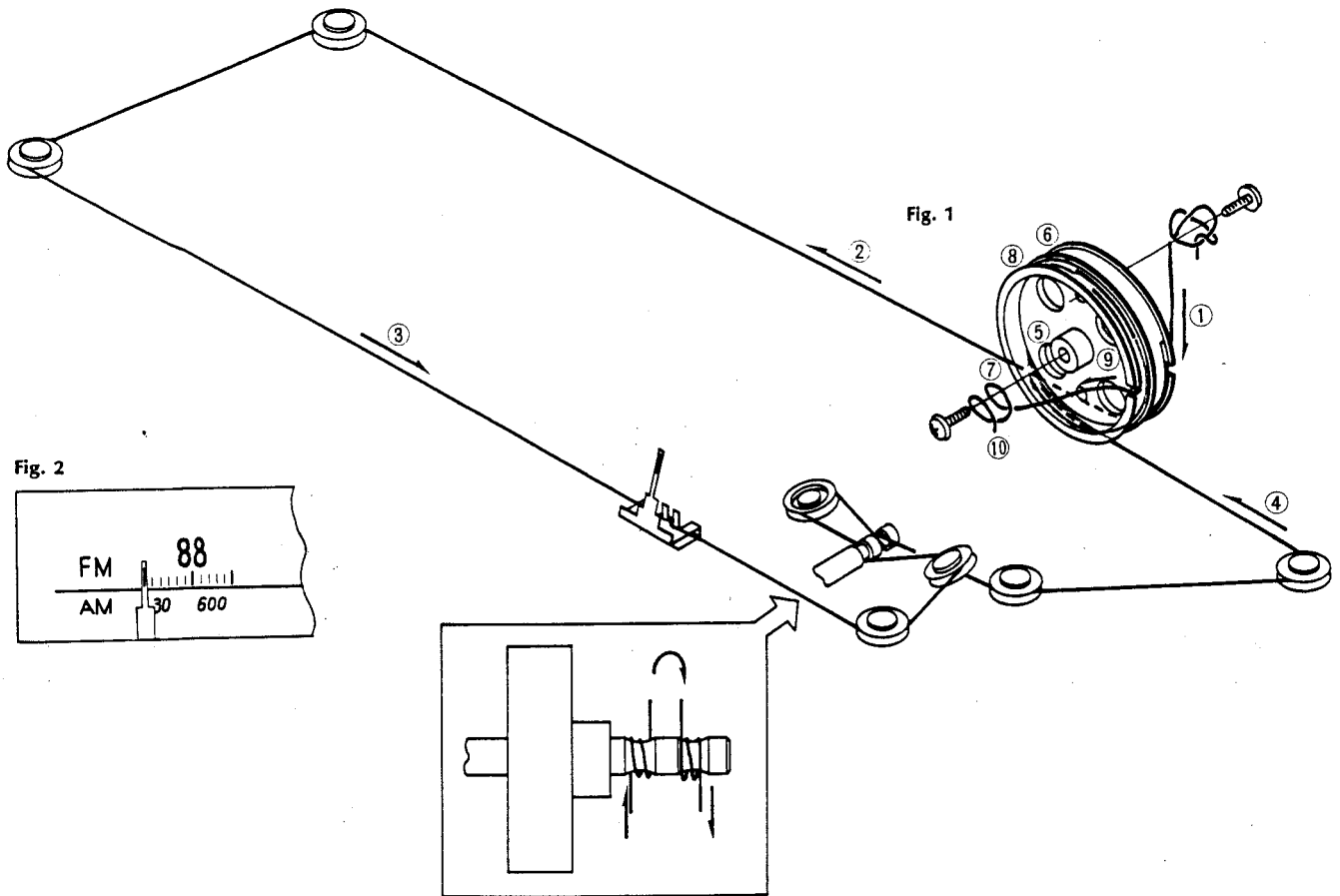

7-1. Threading of Dial Cord

Thread the dial cord in numerical order from ① to ⑩ as Fig. 1.

*Open the variable capacitor completely.

7-2. Attachment of Dial Pointer

1) Close the variable capacitor completely.

2) Set the dial pointer to 530Hz on dial scale as Fig. 2.

*Confirm that the dial pointer runs smoothly on the dial scale by turning the turning shaft.

Stock No.	Description
6036050	Dial Cord (0.5mmφ)
6146721	Dial pulley