

Service Manual

Portable Compact Disc Player

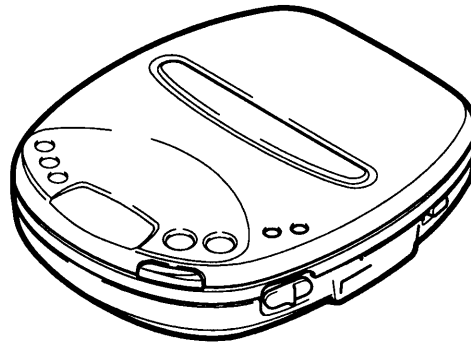

CDP-360(AU)
(XE)
CDP-360BX(SS)
CDP-360CR(AU)
(CA)
(UK)
CDP-360E(CA)
CDP-370(UK)
CDP-400(XE)
CDP-400CR(UK)
CDP-560(UK)
CDP-640CR(CA)

Specifications

Channels	2 channels
Frequency Response	20 ~ 20 kHz
S/N ratio	60 dB
Frequency Response	20 ~ 20 kHz
Wow / Flutter	Below measurable limits
Error Correction Method	CIRC
Wow & Flutter	undetectable
Sampling frequency	44.1kHz
D/A converter	1-bit
Pick-up light source	Semi-conductor laser
Pick-up wavelength	790nm
Laser output	Continuous wave max. 0.5mW
Terminal impedance	PHONES:16 - 32 ohms Line OUT: 47 kohms
Power source	AC : 230V - 240V , 50Hz(AU) AC : 230V , 50Hz(UK , XE) AC : 120V , 60Hz(CA) DC : 3V(Ni-Cd battery NBP-50A or AA x 2)(AU) DC : 3V(Ni-Cd battery NBP-50A or HP7 x 2)(UK) DC : 12V(Cigarette lighter adaptor)(AU)

Maximum Output

(stereo headphones)	10 mW / ch
Dimensions	132.5 x 30 x 152.5mm(W x H x D)
Weight(approx.)	235g without batteries

PRODUCT CODE No.

CDP-360(AU)	142 685 01
CDP-360(XE)	142 685 03
CDP-360BX(SS)	164 003 00
CDP-360CR(AU)	142 686 02
CDP-360CR(CA)	142 686 03
CDP-360CR(UK)	142 686 04
CDP-360E(CA)	142 686 01
CDP-370(UK)	142 685 04
CDP-400(XE)	142 687 01
CDP-400CR(UK)	142 688 01
CDP-560(UK)	164 005 00
CDP-640CR(CA)	164 006 00

Notice

SANYO

- | | |
|--|--|
| <input checked="" type="checkbox"/> CORRECTION | <input type="checkbox"/> PRODUCTION CHANGE |
| <input type="checkbox"/> SERVICE FLASH | <input type="checkbox"/> ADD INFORMATION |
| <input type="checkbox"/> | <input type="checkbox"/> |

FILE NO.

Please add this notice to the Service Manual listed below.

Category : <u>Personal Compact Disc Player</u>	Date : <u>Jul, 1997</u>
<u>CDP-360 , 370 , 400 , 560 , 640 Series</u>	
Model :	
Destination : <u>Below</u>	Reference No. : <u>SM580830</u>
Issue Number : <u>1</u>	

The reason of change.

- | | | |
|--------------|---------------------------|---------------------|
| A : Misprint | B : Quality Reliabilities | C : Standardization |
| D : Design | E : | F : |
| G : | | |

Page & Section	Ref. No.		Part No.	Description	Q'ty	Interchangeability	Reason
PARTS LIST	-	Old	-	-	-		-
P10	110	New	645 025 3089	LASER PICK UP , KSS-542A	1		A

- Prod. cord : 142 685 01 : CDP-360(AU)
 142 685 03 : CDP-360(XE)
 164 003 00 : CDP-360BX(SS)
 142 686 02 : CDP-360CR(AU)
 142 686 03 : CDP-360CR(CA)
 142 686 04 : CDP-360CR(UK)
 142 686 01 : CDP-360E(CA)
 142 685 04 : CDP-370(UK)
 142 687 01 : CDP-400(XE)
 142 688 01 : CDP-400CR(UK)
 164 005 00 : CDP-560(UK)
 164 006 00 : CDP-640CR(CA)

SANYO Technosound Co., Ltd
Osaka , Japan

Notice

- | | | | |
|-------------------------------------|---------------|--------------------------|-------------------|
| <input type="checkbox"/> | CORRECTION | <input type="checkbox"/> | PRODUCTION CHANGE |
| <input checked="" type="checkbox"/> | SERVICE FLASH | <input type="checkbox"/> | ADD INFORMATION |
| <input type="checkbox"/> | | <input type="checkbox"/> | |

FILE NO.

Please add this notice to the Service Manual listed below.

Category : <u>Portable Compact Disc Player</u>	Date : <u>Nov. 1997</u>
Model : <u>CDP-360, 370, 400, 560, 640 Series</u>	
Destination : <u>Below</u>	Reference No. : <u>SM580830</u>
	Issue Number : <u>2</u>

The reason of change.

A : Misprint

B : Quality Reliabilities

C : Standardization

D : Design

E :

F :

G :

Page & Section	Ref. No.		Part No.	Description	Q'ty	Reason
Page 8 PARTS LIST	13	Old	614 290 3827	ASSY, CABINET (360/XE • AU, 360BX/SS, 360CR/UK • AU, 370/UK, 400/XE, 400CR/UK, 560/UK)	1	B
	13	New	614 297 8320	ASSY, CABINET (360/XE • AU, 360BX/SS, 360CR/UK • AU, 370/UK, 400/XE, 400CR/UK, 560/UK)	1	B
	13	Old	614 293 0847	ASSY, CABINET (360CR/CA, 360E/CA, 640CR/CA)	1	B
	13	New	614 297 8337	ASSY, CABINET (360CR/CA, 360E/CA, 640CR/CA)	1	B
	18	Old	614 290 5425	BUTTON, EJECT	1	B
	18	New	614 297 7293	BUTTON, EJECT	1	B

Prod. cord : 142 685 01 : CDP-360 (AU)
 142 685 03 : CDP-360 (XE)
 164 003 00 : CDP-360BX (SS)
 142 686 02 : CDP-360CR (AU)
 142 686 03 : CDP-360CR (CA)
 142 686 04 : CDP-360CR (UK)
 142 686 01 : CDP-360E (CA)
 142 685 04 : CDP-370 (UK)
 142 687 01 : CDP-400 (XE)
 142 688 01 : CDP-400CR (UK)
 164 005 00 : CDP-560 (UK)
 164 006 00 : CDP-640CR (CA)

SANYO Technosound Co., Ltd

Osaka, Japan

LASER BEAM SAFETY PRECAUTIONS

- Pickup that emits a laser beam is used on this CD section.

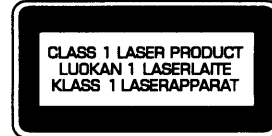
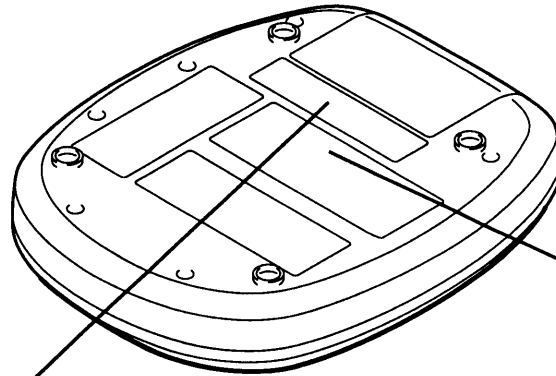

AU , XE & UK

CAUTION :
THIS PRODUCT CONTAINS A LOW POWER LASER DEVICE, TO ENSURE CONTINUES SAFETY DO NOT REMOVE ANY COVERS OR ATTEMPT TO GAIN ACCESS TO THE INSIDE OF PRODUCT. REFER ALL SERVICING TO QUALIFIED PERSONNEL.

CAUTION :
USE OF CONTROLS OR ADJUSTMENTS OR PERFORMANCE OF PROCEDURES OTHER THAN THOSE SPECIFIED HEREIN MAY RESULT IN HAZARDOUS RADIATION EXPOSURE.

AU

UK

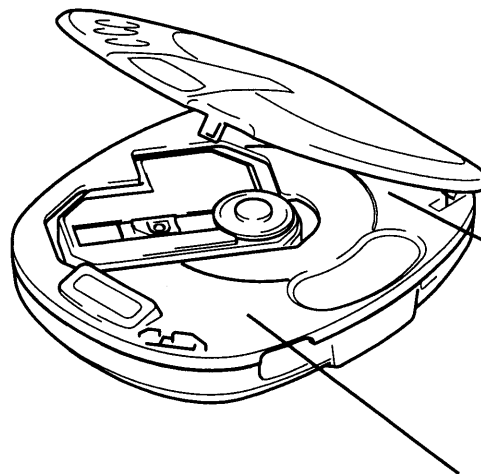

XE & AU

CAUTION – INVISIBLE LASER RADIATION WHEN OPEN AND INTERLOCKS DEFEATED. AVOID EXPOSURE TO BEAM.
ADVARSEL – USYNLIG LASER STRÅLING VED ÅBNING, NÅR SIKKERHEDSAFBRYDERE ER UDE AF FUNKTION, UNDGÅ UDSÆTTELSE FOR STRÅLING.
VARNING – OSYNLIG LASER STRÅLNING NÅR DENNA DEL ÄR ÖPPNAD OCH SPÄRR ÄR URKOPPLAD. STRÅLEN ÄR FARLIG.
VORSICHT – UNSICHTBARE LASERSTRAHLUNG TRITT AUS, WENN DECKEL GEÖFFNET UND WENN SICHERHEITVERRIEGELUNG ÜBERBRÜCKT IST. NICHT, DEM STRAHL AUSSETZEN.
VARO! Avattaessa ja suojalukitus ohitettaessa olet alltiina näkymättömälle lasersäteilylle. Älä katso äteeseen.

XE & AU

REMOVAL AND INSTALLATION

- Disconnect the AC adaptor's plug.
- Remove the batteries.
- All wiring should be returned to the original position after work is completed.

a. CABINET, BOTTOM

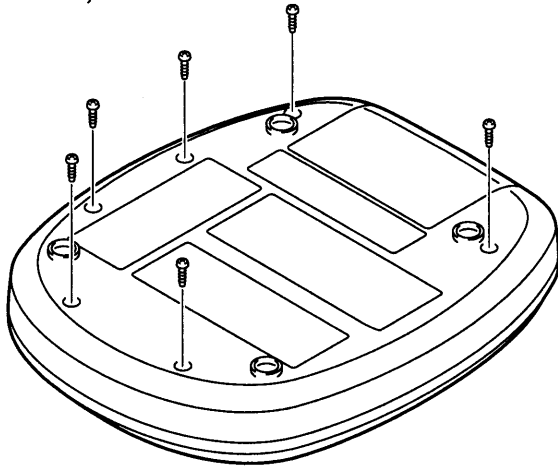

b. CABINET

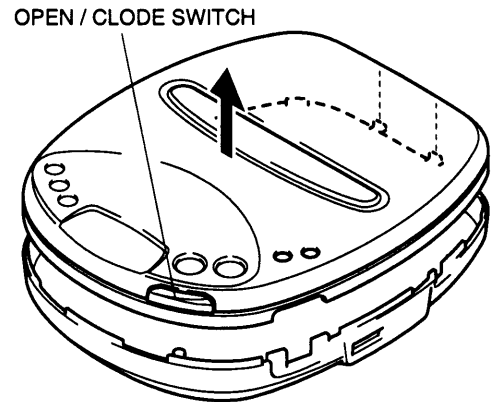

c. CD LID

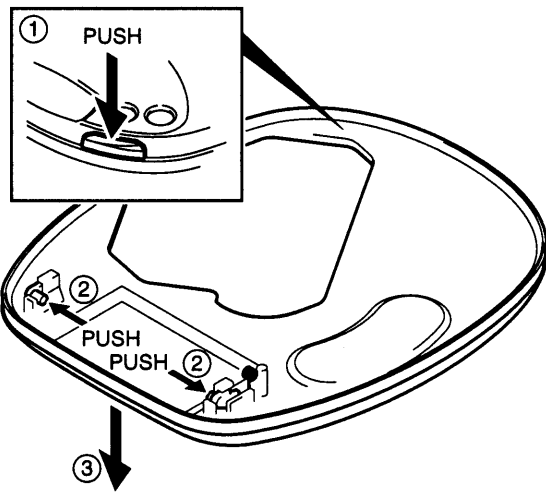

d. CD MECHANISM

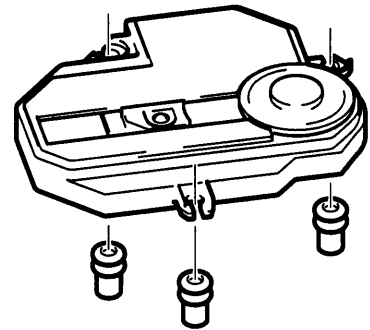
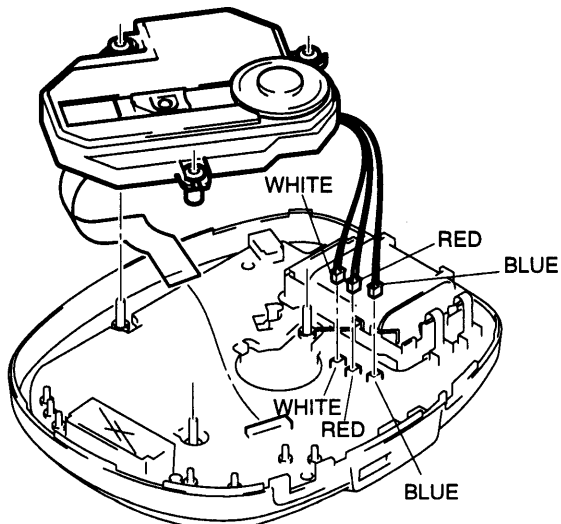

REMOVAL AND INSTALLATION

e. CD P.W.BOARD

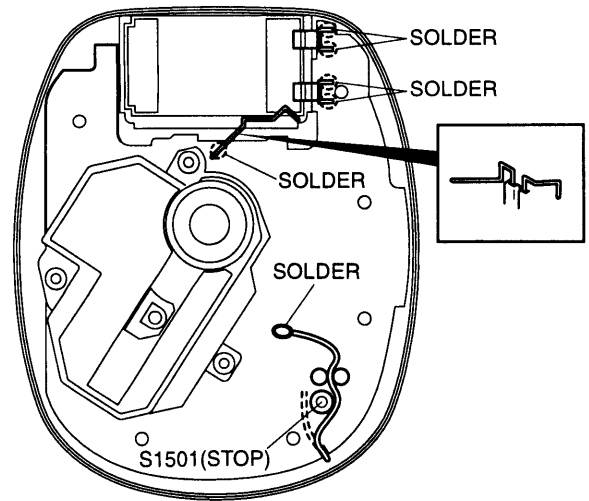
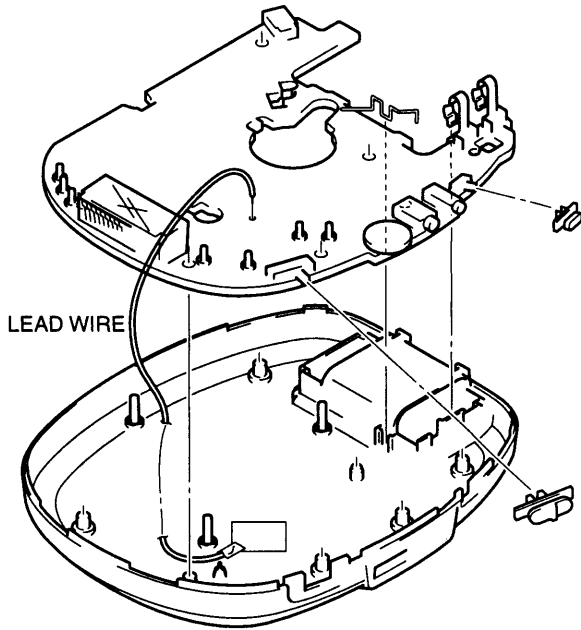

f. WIRING LAYOUT

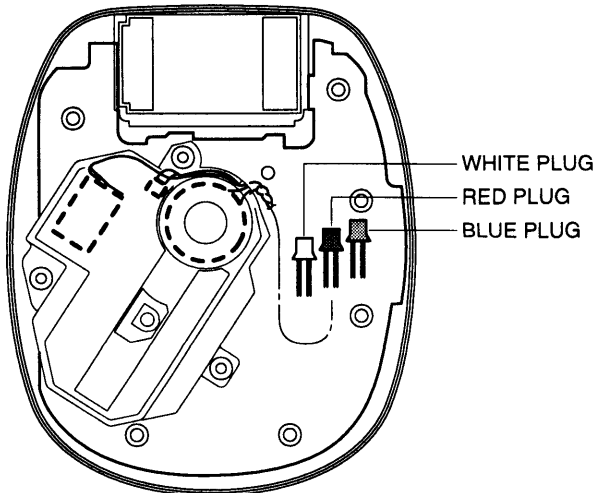
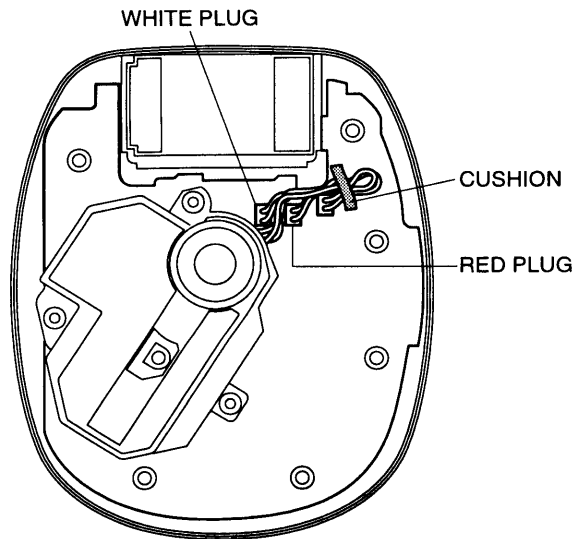
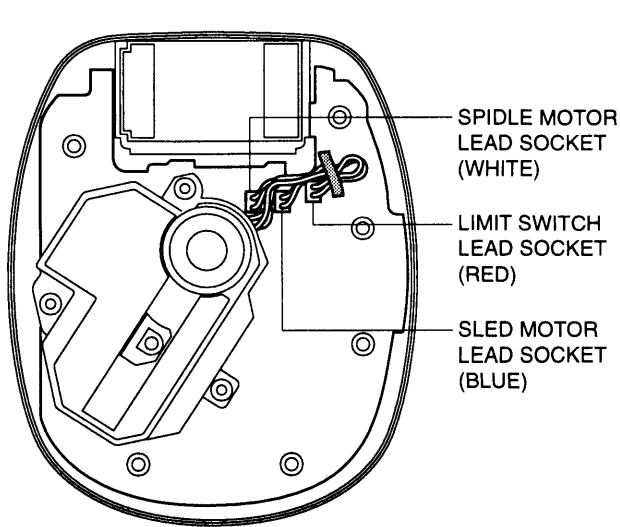

CD ADJUSTMENTS

a. PREPARATIONS

• Measuring instruments, tools and filter

- (1) Test disc : YEDS 18 (SONY) or etc.
- (2) Oscilloscope : SS5711 (10 MHz or dual-trace)
or Memoryscope : DSS6521 (Storagescope)
- (3) EXT. DC POWER : DC 6V, 1A
- (4) Screwdrivers (non-metallic) for adjustments

b. PARTS LOCATION

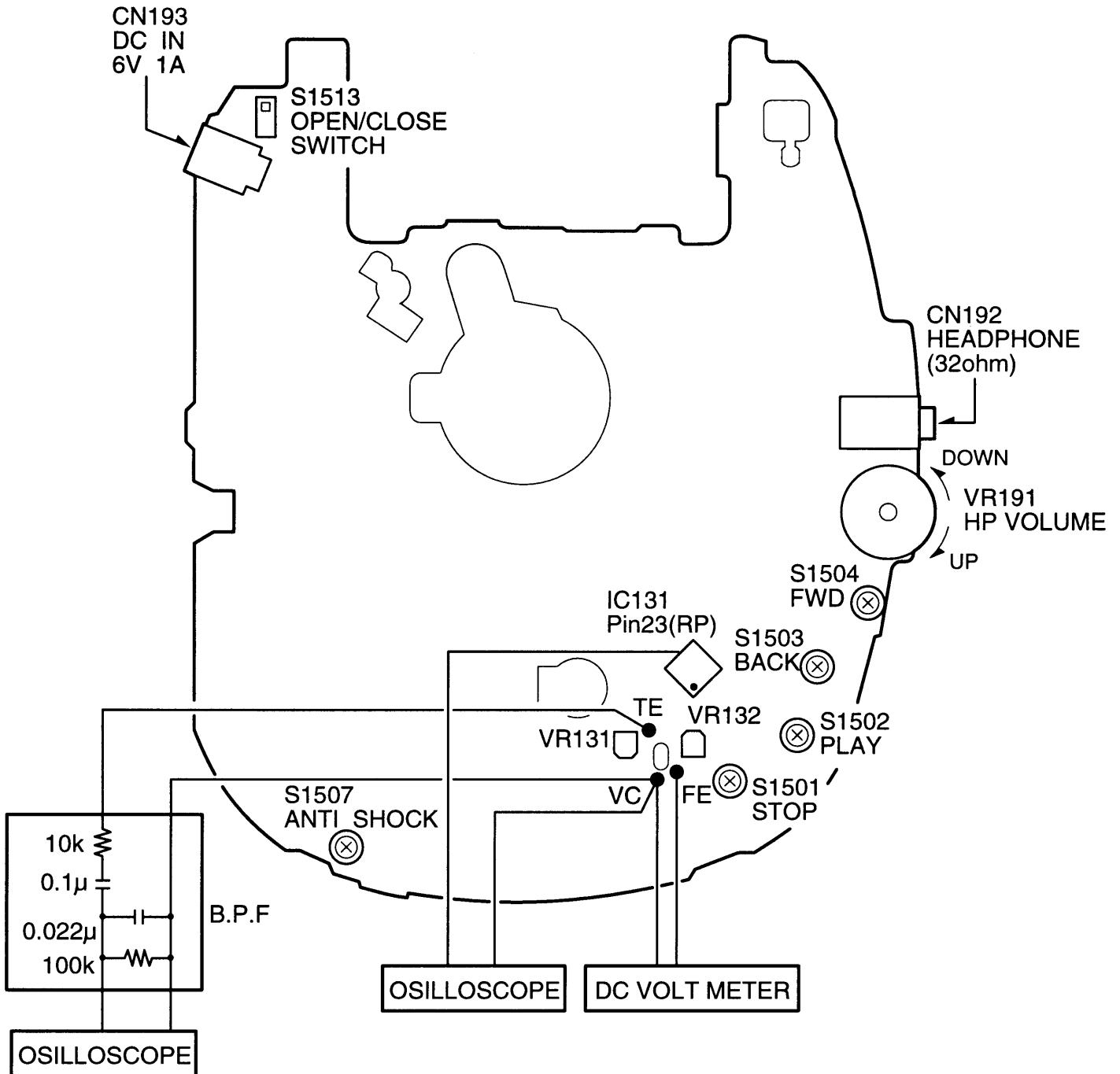

CD ADJUSTMENTS

c. ADJUSTMENTS

Adjustment Item	Measuring instrument	Service mode	Output connection	Adjustment location	Adjustment value
(a) Tracking balance	Oscilloscope L.P.F	yes	TE VC	VR131	Waveform symmetry A = B
(b) Checking the "eye" pattern	Oscilloscope	-	IC131(23Pin) : RF VC	-	Check be sure that the "eye" pattern is at the center of the waveform and that the diamond shape is clearly defined

(a) TRACKING BALANCE ADJUSTMENT

- (1) Connect the oscilloscope to TE and VC.
- (2) Set the test disc.
- (3) Turn open closing switch on PWB ASSY(S1513) into an open state, and does DC power supply in on while pushing STOP Key(S1501) and ANTI-SHOCK Key(S1507) simultaneously, and confirms that all segments of LCD become indication state. (Establishes a microcomputer in movement test mode)
- (4) Pushes the first time and pushes PLAY state and the second time and becomes rough servo state.
- (5) Turn on PWB ASSY VR131 with a driver for adjustment slowly from side to side, and adjusts it as wave pattern of "TE" becomes symmetric top and bottom.

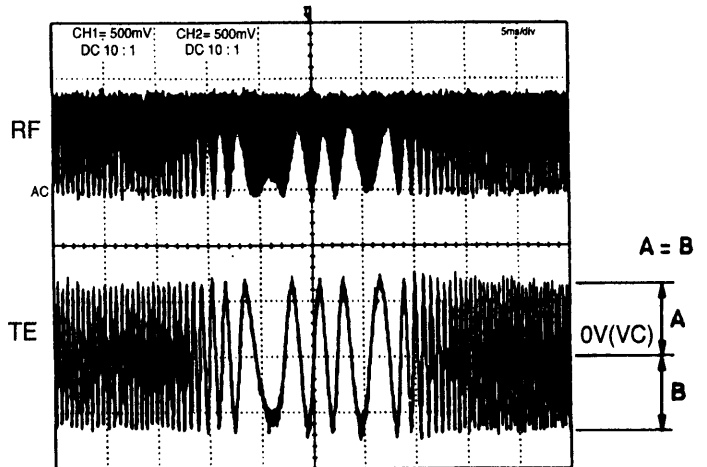

(b) CHECKING THE "EYE" PATTERN

- (1) Connect the oscilloscope to IC131 (pin23) (RF) and (VC).
- (2) Switch "ON" the POWER.
- (3) Load the test disc.
- (4) Press the PLAY button.
- (5) Check to be sure that the "eye" pattern is at the center of waveform and that the diamond shape is clearly defined.
- (6) Press the STOP button.
- (7) Switch "OFF" the DC POWER.

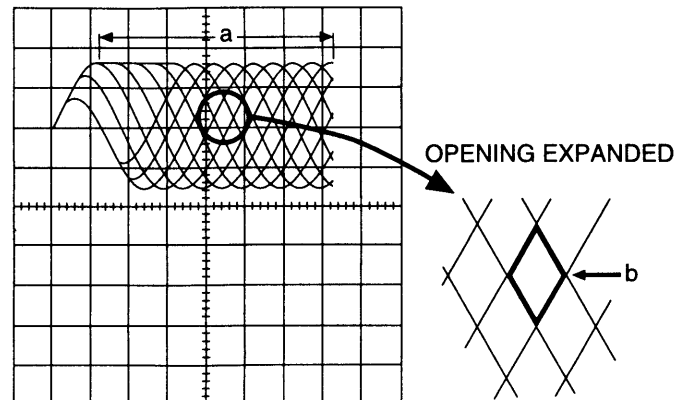

(d) Focus adjustment

- (1) Pushes PLAY key(S1502) once and play.
- (2) Record an indicator value of voltmeter.(V1)
- (3) Pushes STOP key(S1501) and stop.
- (4) Stops PWB ASSY VR132 by the time while reading an indicator value of a voltmeter(V2) it became it with right and left slow gang bang, V1-V2 < 5mV with adjustment driver.
- (5) Switch "OFF" the DC POWER.

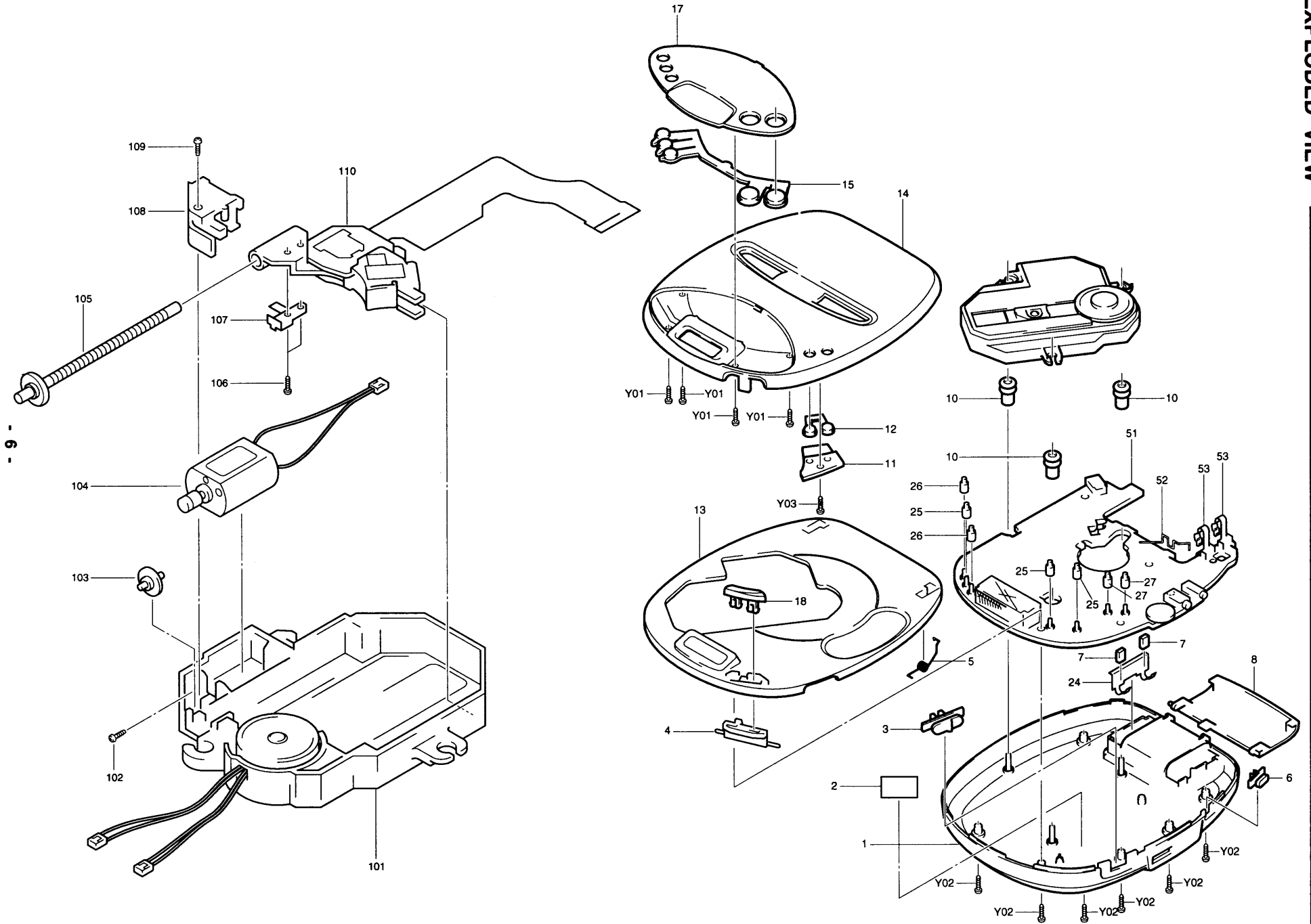

PARTS LIST

PRODUCT SAFETY NOTICE

EACH PRECAUTION IN THIS MANUAL SHOULD BE FOLLOWED DURING SERVICING. COMPONENTS IDENTIFIED WITH THE IEC SYMBOL Δ IN THE PARTS LIST AND THE SCHEMATIC DIAGRAM DESIGNATED COMPONENTS IN WHICH SAFETY CAN BE OF SPECIAL SIGNIFICANCE. WHEN REPLACING A COMPONENT IDENTIFIED BY Δ , USE ONLY THE REPLACEMENT PARTS DESIGNATED, OR PARTS WITH THE SAME RATINGS OF RESISTANCE, WATTAGE OR VOLTAGE THAT ARE DESIGNATED IN THE PARTS LIST IN THIS MANUAL. LEAKAGE-CURRENT OR RESISTANCE MEASUREMENTS MUST BE MADE TO DETERMINE THAT EXPOSED PARTS ARE ACCEPTABLY INSULATED FROM THE SUPPLY CIRCUIT BEFORE RETURNING THE PRODUCT TO THE CUSTOMER.

PACKING & ACCESSORY

REF.NO.	PART NO.	DESCRIPTION	REF.NO.	PART NO.	DESCRIPTION
	614 292 6369	CARTON CASE,INNER(CDP-360/AU)		614 252 7764	HEADPHONE(CDP-360BX/SS)
	614 292 6383	CARTON CASE,INNER (CDP-640CR/CA)			(CDP-360CR/UK)(CDP-360CR/AU)
	614 292 6390	CARTON CASE,INNER (CDP-360CR/AU)			(CDP-370/UK)(CDP-360/XE)
	614 292 6406	CARTON CASE,INNER (CDP-360CR/CA)		645 016 2213	HEADPHONE,32(CDP-360CR/CA)
	614 292 6413	CARTON CASE,INNER (CDP-360CR/UK)			(CDP-360E/CA)(CDP-640CR/CA)
	614 293 1486	CARTON CASE,INNER(CDP-360/XE)		645 017 8771	HEADPHONE,16(CDP-560/UK)
	614 293 1493	CARTON CASE,INNER(CDP-560/UK)	Δ	645 011 8326	PLUG,ADAPTOR AC(CDP-360BX/SS)
	614 293 1509	CARTON CASE,INNER(CDP-400/XE)		645 024 3448	ADAPTOR,DC-DC(CDP-360BX/SS)
	614 293 1523	CARTON CASE,INNER (CDP-400CR/UK)			(CDP-360CR/UK)(CDP-360CR/CA)
	614 293 4982	CARTON CASE,INNER(CDP-370/UK)			(CDP-360CR/AU)(CDP-360E/CA)
	614 293 1608	CARTON CASE,INNER(CDP-360E/CA)	Δ	645 024 7262	ADAPTOR,AC-DC,6CV-120US2
	614 294 6169	CARTON CASE,INNER(CDP-360BX/SS)			(CDP-360CR/CA)(CDP-360E/CA)
	614 292 6451	INSTRUCTION MANUAL(CDP-360/AU)	Δ	645 024 7408	ADAPTOR,AC-DC,6CV-240AU2
	614 292 6475	INSTRUCTION MANUAL (CDP-640CR/CA)			(CDP-360CR/AU)(CDP-640CR/CA)
	614 292 6482	INSTRUCTION MANUAL (CDP-360CR/AU)	Δ	645 024 7415	ADAPTOR,AC-DC,6CV-230XE2
	614 292 6499	INSTRUCTION MANUAL (CDP-360CR/CA)(CDP-360E/CA)	Δ	645 024 7422	ADAPTOR,AC-DC,6CV-230UK2
	614 292 6505	INSTRUCTION MANUAL (CDP-360CR/UK)			(CDP-370/UK)(CDP-560/UK)
	614 293 1653	INSTRUCTION MANUAL(CDP-360/XE)	Δ	645 024 7439	ADAPTOR,AC-DC,6CV230SS2,
	614 295 3914	INSTRUCTION MANUAL (CDP-360BX/SS)			ADAPTOR AC-DC(CDP-360BX/SS)
	614 293 1677	INSTRUCTION MANUAL(CDP-560/UK)		645 017 6104	ADAPTOR,CAR CASSETTE
	614 293 1691	INSTRUCTION MANUAL(CDP-400/XE)			(CDP-360BX/SS)(CDP-360CR/UK)
	614 293 1721	INSTRUCTION MANUAL (CDP-400CR/UK)		645 022 9688	SPEAKER(CDP-360BX/SS)
	614 293 5064	INSTRUCTION MANUAL(CDP-370/UK)		645 025 7179	ADAPTOR,CAR CASSETTE
	614 280 6890	CASE,CARRYING(CDP-400/XE)	or		(CDP-360CR/CA)(CDP-360E/CA)
	614 281 1894	CASE(CDP-360BX/SS)		645 011 9071	CABLE,Y,RCA-2P
	614 283 0963	CAUTION,DISC		645 017 8832	CABLE,Y,RCA-2P
	614 231 6832	LABEL,SAFETY,CABI BOTTOM (CDP-360BX/SS)(CDP-360CR/UK)			
		(CDP-360CR/AU)(CDP-370/UK)			
		(CDP-360/XE)(CDP-360/AU)			
		(CDP-560/UK)(CDP-400CR/UK)			
		(CDP-400/XE)			
	614 283 7733	LABEL,LID-BATTERY(CDP-360BX/SS)	1	614 290 5357	ASSY,CABINET,BOTTOM
	645 011 9880	POLY SHEET-0450X0250*NC,SET			(CDP-360/AU)
	645 017 9136	ASSY,BATTERY,RECHARGE (CDP-560/UK)(CDP-400CR/UK)	1	614 293 0533	ASSY,CABINET,BOTTOM
		(CDP-400/XE)			(CDP-360CR/UK)(CDP-360CR/CA)
	645 017 9143	ASSY,BATTERY,RECHARGE (CDP-360BX/SS)(CDP-360CR/AU)	1	614 293 1233	ASSY,CABINET,BOTTOM
		(CDP-360/AU)			(CDP-360/XE)
	645 024 6807	ASSY,BATTERY,RECHARGE (CDP-560/UK)(CDP-400CR/UK)	1	614 293 1240	ASSY,CABINET,BOTTOM
		(CDP-400/XE)			(CDP-360E/CA)
	645 024 6814	ASSY,BATTERY,RECHARGE (CDP-360BX/SS)(CDP-360CR/AU)	1	614 293 1257	ASSY,CABINET,BOTTOM
		(CDP-360/AU)			(CDP-560/UK)
				614 293 1264	ASSY,CABINET,BOTTOM
					(CDP-400/XE)
				614 293 1288	ASSY,CABINET,BOTTOM
					(CDP-400CR/UK)

CABINET & CHASSIS

REF.NO.	PART NO.	DESCRIPTION
	614 276 2844	LABEL,SAFETY (CDP-360BX/SS)(CDP-360CR/UK)
		(CDP-360CR/AU)(CDP-370/UK)
		(CDP-360/XE)(CDP-360/AU)
		(CDP-380/UK)(CDP-560/UK)
	614 290 5357	ASSY,CABINET,BOTTOM (CDP-360/AU)
	614 293 0533	ASSY,CABINET,BOTTOM (CDP-360CR/UK)(CDP-360CR/CA)
		(CDP-360CR/AU)
	614 293 1233	ASSY,CABINET,BOTTOM (CDP-360/XE)
	614 293 1240	ASSY,CABINET,BOTTOM (CDP-360E/CA)
	614 293 1257	ASSY,CABINET,BOTTOM (CDP-560/UK)
	614 293 1264	ASSY,CABINET,BOTTOM (CDP-400/XE)
	614 293 1288	ASSY,CABINET,BOTTOM (CDP-400CR/UK)

PARTS LIST

REF.NO.	PART NO.	DESCRIPTION	REF.NO.	PART NO.	DESCRIPTION
1	614 293 4272	ASSY,CABINET,BOTTOM (CDP-370/UK)	CN141	645 023 8796	PLUG,2P
1	614 294 6022	ASSY,CABINET,BOTTOM (CDP-360BX/SS)	CN142	645 009 9007	PLUG,2P
1	614 293 0557	ASSY,CABINET,BOTTOM (CDP-640CR/CA)	CN143	645 023 8802	PLUG,2P
2	614 293 3343	SHIELD	CN191	645 000 1413	JACK,PHONE D3.6
3	614 290 5586	KNOB,SLIDE,FLAT-A-B	CN192	645 016 1827	JACK,PHONE D3.6
4	614 290 5623	LEVER	CN193	645 011 8890	SOCKET,DC
5	614 290 5692	SPRING,TORSION,LID OPEN	D1401	407 164 4002	DIODE RB160L-40
6	614 290 5579	KNOB,SLIDE,HOLD	D1412	407 003 4507	DIODE DAP202K
7	614 267 3584	STAND,SPRING PLATE(+,-)	D1421	407 164 4002	DIODE RB160L-40
8	614 290 5609	LID,BATTERY	D1422	407 164 4002	DIODE RB160L-40
10	614 290 5661	SPACER,MECHA,CD,MECHA	D1431	407 164 4002	DIODE RB160L-40
11	614 290 5487	COVER,BUTTON COVER	D1505	407 149 0807	DIODE 1SS355
12	614 290 5401	BUTTON,FWD/BACK	D1506	407 149 0807	DIODE 1SS355
13	614 290 3827	ASSY,CABINET (CDP-360BX/SS)(CDP-360CR/UK)	D1509	407 149 0807	DIODE 1SS355
		(CDP-360CR/AU)(CDP-370/UK)	D1901	407 187 8001	ZENER DIODE UDZ10B
		(CDP-360/XE)(CDP-360/AU)	D1902	407 187 8001	ZENER DIODE UDZ10B
		(CDP-380/UK)(CDP-560/UK)(400CR/UK)	D1903	407 148 7609	DIODE DAN217
13	614 293 0847	ASSY,CABINET (CDP-360CR/CA)(CDP-360E/CA)	D1941	407 148 7609	DIODE DAN217
		(CDP-640CR/CA)	D1991	407 164 4002	DIODE RB160L-40
14	614 290 5371	ASSY,LID,CD (CDP-360BX/SS)(CDP-360CR/UK)	IC131	409 402 7103	IC BA6387K
		(CDP-360CR/AU)(CDP-370/UK)	IC141	409 402 7301	IC BA6894K
		(CDP-360/XE)(CDP-360/AU)	IC142	409 371 1102	IC RN5RG33AA
14	614 293 1073	ASSY,LID,CD (CDP-360CR/CA)(360E/CA)	IC143	409 401 7609	IC S-8322AIMP-DOI
			IC145	409 402 7202	IC BU9321KS
14	614 293 1080	ASSY,LID,CD(CDP-640CR/CA)	IC146	409 401 7401	IC SM5859AF
14	614 293 1295	ASSY,LID,CD (CDP-560/UK)(CDP-400/XE)(400CR/UK)	IC147	409 401 7401	IC SM5859AF(CDP-640CR/CA)
15	614 290 5395	BUTTON,DEC, LCD	or	410 288 9808	IC HM51W4400BTT-7(CDP-640CR/CA)
17	614 290 4657	DEC,LCD		410 288 9907	IC HM51W4400BLTT-7(CDP-640CR/CA)
18	614 290 5425	BUTTON,EJECT		410 264 5909	IC HM51W4400BSL-7-EL (CDP-640CR/CA)
24	614 290 5760	SPRING,PLATE,+,-	IC147	410 295 8504	IC LC32V4256BM-15A-TLM
25	614 290 5418	BUTTON,BASE,PLAY/STOP/P-MODE	IC151	410 294 1803	IC BU34581-05
26	614 294 5797	BUTTON BASE,M-SET/ANTI-S	IC191	409 365 9503	IC SM5877AM
27	614 294 5803	BUTTON BASE,SKIP	IC192	409 081 6909	IC LA4533M

FIXNG PARTS

REF.NO.	PART NO.	DESCRIPTION
Y01	411 019 0002	SXR FLT PCS 1.4X3.5,DEC LCD
Y02	411 022 6800	SCR S-TPG PAN 2X10,
Y03	411 019 0002	SXR FLT PCS 1.4X3.5,COVER

CONTROL-CIRCUIT

REF.NO.	PART NO.	DESCRIPTION
51	614 290 5975	ASSY,PWB CD
51	614 290 6163	ASSY,PWB CD(CDP-640CR/CA)
52	614 292 9834	SPRING,PLATE,+/-
53	614 283 8433	TERMINAL,CHARGER
A1501	645 024 0799	LCD
C1308	404 060 2705	OS-SOLID 10U M 10V
C1309	403 216 2507	TA-SOLID 47U M 4V
C1409	403 311 1603	TA-SOLID 22U M 4V
C1419	403 276 7108	TA-SOLID 10U M 4V
C1437	404 060 2705	OS-SOLID 10U M 10V
C1452	404 060 2705	OS-SOLID 10U M 10V
C1466	403 190 7109	TA-SOLID 2.2U M 10V
or	403 114 5402	TA-SOLID 2.2U M 10V
or	403 306 3100	TA-SOLID 2.2U M 10V
C1469	403 323 8409	TA-SOLID 3.3U M 6.3V
C1503	403 276 7108	TA-SOLID 10U M 4V
C1903	403 216 2507	TA-SOLID 47U M 4V
CN101	645 024 7231	SOCKET,FPC 15P
or	645 023 1506	SOCKET,FPC 15P

PARTS LIST

REF.NO.	PART NO.	DESCRIPTION	REF.NO.	PART NO.	DESCRIPTION
Q1702	405 021 2406	TR 2SD1048-X7	R1467	401 037 8005	MT-GLAZE 15K JA 1/10W
Q1721	405 029 3207	TR DTC114TK	R1468	401 039 0502	MT-GLAZE 82K JA 1/10W
Q1801	405 021 2406	TR 2SD1048-X7	R1469	401 038 6406	MT-GLAZE 4.7K JA 1/10W
Q1802	405 021 2406	TR 2SD1048-X7	R1471	401 036 8303	MT-GLAZE 4.7K JA 1/8W
Q1821	405 029 3207	TR DTC114TK	R1478	401 038 6307	MT-GLAZE 470 JA 1/10W
Q1911	405 000 1109	TR DTA124EK	R1483	401 037 5608	MT-GLAZE 10K JA 1/10W
Q1925	405 002 0308	TR 2SA1037K-R	R1484	401 038 6604	MT-GLAZE 470K JA 1/10W
or	405 005 5508	TR 2SA812-M6	R1485	401 039 0403	MT-GLAZE 8.2K JA 1/10W
R1011	401 035 4108	MT-GLAZE 0.000 ZA 1/8W	R1486	401 039 0403	MT-GLAZE 8.2K JA 1/10W
R1012	401 035 4108	MT-GLAZE 0.000 ZA 1/8W	R1487	401 037 5004	MT-GLAZE 0.000 ZA 1/10W
R1013	401 035 4108	MT-GLAZE 0.000 ZA 1/8W	R1490	401 037 5400	MT-GLAZE 1K JA 1/10W
R1303	401 037 5400	MT-GLAZE 1K JA 1/10W	R1491	401 038 7601	MT-GLAZE 560 JA 1/10W
R1305	401 039 0809	MT-GLAZE 91 JA 1/10W	R1492	401 038 7601	MT-GLAZE 560 JA 1/10W
R1307	401 037 8005	MT-GLAZE 15K JA 1/10W	R1493	401 038 7601	MT-GLAZE 560 JA 1/10W
R1308	401 038 6406	MT-GLAZE 4.7K JA 1/10W	R1494	401 038 7601	MT-GLAZE 560 JA 1/10W
R1309	401 038 2309	MT-GLAZE 270K JA 1/10W	R1495	401 038 7601	MT-GLAZE 560 JA 1/10W
R1310	401 038 2309	MT-GLAZE 270K JA 1/10W	R1496	401 038 7601	MT-GLAZE 560 JA 1/10W
R1311	401 038 0800	MT-GLAZE 22K JA 1/10W	R1501	401 038 7908	MT-GLAZE 560K JA 1/10W
R1313	401 037 5103	MT-GLAZE 10 JA 1/10W	R1503	401 038 6505	MT-GLAZE 47K JA 1/10W
R1315	401 037 6803	MT-GLAZE 12K JA 1/10W	R1504	401 038 7908	MT-GLAZE 560K JA 1/10W
R1316	401 037 5004	MT-GLAZE 0.000 ZA 1/10W	R1505	401 037 5608	MT-GLAZE 10K JA 1/10W
R1320	401 038 5300	MT-GLAZE 39K JA 1/10W	R1506	401 037 5608	MT-GLAZE 10K JA 1/10W
R1321	401 038 5300	MT-GLAZE 39K JA 1/10W	R1507	401 038 0701	MT-GLAZE 2.2K JA 1/10W
R1322	401 038 5300	MT-GLAZE 39K JA 1/10W	R1508	401 038 3603	MT-GLAZE 3.3K JA 1/10W
R1323	401 038 5300	MT-GLAZE 39K JA 1/10W	R1509	401 038 6406	MT-GLAZE 4.7K JA 1/10W
R1324	401 038 5300	MT-GLAZE 39K JA 1/10W	R1510	401 037 5608	MT-GLAZE 10K JA 1/10W
R1325	401 037 5004	MT-GLAZE 0.000 ZA 1/10W	R1511	401 038 2200	MT-GLAZE 27K JA 1/10W
R1326	401 037 5004	MT-GLAZE 0.000 ZA 1/10W	R1515	401 037 5400	MT-GLAZE 1K JA 1/10W
R1341	401 038 6505	MT-GLAZE 47K JA 1/10W	R1520	401 037 5004	MT-GLAZE 0.000 ZA 1/10W
R1347	401 038 6406	MT-GLAZE 4.7K JA 1/10W	R1521	401 037 5004	MT-GLAZE 0.000 ZA 1/10W (CDP-640CR/CA)
R1349	401 037 5004	MT-GLAZE 0.000 ZA 1/10W	R1554	401 038 6505	MT-GLAZE 47K JA 1/10W
R1358	401 037 5608	MT-GLAZE 10K JA 1/10W	R1555	401 037 5707	MT-GLAZE 100K JA 1/10W
R1371	401 037 5004	MT-GLAZE 0.000 ZA 1/10W	R1557	401 037 5608	MT-GLAZE 10K JA 1/10W
R1372	401 038 6505	MT-GLAZE 47K JA 1/10W	R1559	401 035 5402	MT-GLAZE 100K JA 1/8W
R1391	401 037 5004	MT-GLAZE 0.000 ZA 1/10W	R1560	401 037 5806	MT-GLAZE 1M JA 1/10W
R1393	401 037 5004	MT-GLAZE 0.000 ZA 1/10W	R1562	401 038 6604	MT-GLAZE 470K JA 1/10W
R1395	401 037 5004	MT-GLAZE 0.000 ZA 1/10W	R1580	401 038 6505	MT-GLAZE 47K JA 1/10W
R1402	401 039 0403	MT-GLAZE 8.2K JA 1/10W	R1584	401 037 5400	MT-GLAZE 1K JA 1/10W
R1403	401 039 0403	MT-GLAZE 8.2K JA 1/10W	R1585	401 037 5608	MT-GLAZE 10K JA 1/10W
R1404	401 039 0403	MT-GLAZE 8.2K JA 1/10W	R1586	401 035 5204	MT-GLAZE 10K JA 1/8W
R1405	401 038 3702	MT-GLAZE 33K JA 1/10W	R1587	401 037 5400	MT-GLAZE 1K JA 1/10W
R1406	401 038 3504	MT-GLAZE 330 JA 1/10W	R1588	401 038 6505	MT-GLAZE 47K JA 1/10W
R1407	401 037 5400	MT-GLAZE 1K JA 1/10W	R1589	401 037 5004	MT-GLAZE 0.000 ZA 1/10W
R1408	401 037 5608	MT-GLAZE 10K JA 1/10W	R1590	401 038 6604	MT-GLAZE 470K JA 1/10W
R1409	401 037 5608	MT-GLAZE 10K JA 1/10W	R1591	401 037 5608	MT-GLAZE 10K JA 1/10W
R1411	401 037 5707	MT-GLAZE 100K JA 1/10W	R1593	401 037 5004	MT-GLAZE 0.000 ZA 1/10W
R1412	401 038 6208	MT-GLAZE 47 JA 1/10W	R1594	401 037 5608	MT-GLAZE 10K JA 1/10W
R1414	401 038 0800	MT-GLAZE 22K JA 1/10W	R1595	401 037 5707	MT-GLAZE 100K JA 1/10W
R1421	401 038 3504	MT-GLAZE 330 JA 1/10W	R1596	401 037 5707	MT-GLAZE 100K JA 1/10W
R1422	401 037 5608	MT-GLAZE 10K JA 1/10W	R1701	401 037 5400	MT-GLAZE 1K JA 1/10W
R1423	401 038 5102	MT-GLAZE 3.9K JA 1/10W	R1702	401 037 5400	MT-GLAZE 1K JA 1/10W
R1424	401 038 6505	MT-GLAZE 47K JA 1/10W	R1703	401 037 5608	MT-GLAZE 10K JA 1/10W
R1426	401 037 5004	MT-GLAZE 0.000 ZA 1/10W	R1704	401 039 0502	MT-GLAZE 82K JA 1/10W
R1432	401 038 3504	MT-GLAZE 330 JA 1/10W	R1705	401 037 5400	MT-GLAZE 1K JA 1/10W
R1433	401 037 5707	MT-GLAZE 100K JA 1/10W	R1706	401 038 0909	MT-GLAZE 220K JA 1/10W
R1434	401 038 0800	MT-GLAZE 22K JA 1/10W	R1707	401 038 3603	MT-GLAZE 3.3K JA 1/10W
R1437	401 037 5004	MT-GLAZE 0.000 ZA 1/10W	R1708	401 038 5508	MT-GLAZE 4.7 JA 1/10W
R1440	401 038 6406	MT-GLAZE 4.7K JA 1/10W	R1710	401 037 5400	MT-GLAZE 1K JA 1/10W
R1441	401 038 6505	MT-GLAZE 47K JA 1/10W	R1711	401 037 5400	MT-GLAZE 1K JA 1/10W
R1442	401 038 0909	MT-GLAZE 220K JA 1/10W	R1751	401 037 5004	MT-GLAZE 0.000 ZA 1/10W
R1443	401 037 5608	MT-GLAZE 10K JA 1/10W	R1752	401 037 5004	MT-GLAZE 0.000 ZA 1/10W
R1453	401 037 5608	MT-GLAZE 10K JA 1/10W	R1801	401 037 5400	MT-GLAZE 1K JA 1/10W
R1457	401 037 5608	MT-GLAZE 10K JA 1/10W	R1802	401 037 5400	MT-GLAZE 1K JA 1/10W
R1461	401 038 7809	MT-GLAZE 56K JA 1/10W	R1803	401 037 5608	MT-GLAZE 10K JA 1/10W
R1463	401 038 7700	MT-GLAZE 5.6K JA 1/10W	R1804	401 039 0502	MT-GLAZE 82K JA 1/10W
R1464	401 038 0909	MT-GLAZE 220K JA 1/10W	R1805	401 037 5400	MT-GLAZE 1K JA 1/10W
R1465	401 037 9309	MT-GLAZE 18K JA 1/10W			
R1466	401 038 5102	MT-GLAZE 3.9K JA 1/10W			

PARTS LIST

REF.NO.	PART NO.	DESCRIPTION
R1806	401 038 0909	MT-GLAZE 220K JA 1/10W
R1807	401 038 3603	MT-GLAZE 3.3K JA 1/10W
R1808	401 038 5508	MT-GLAZE 4.7 JA 1/10W
R1810	401 037 5400	MT-GLAZE 1K JA 1/10W
R1811	401 037 5400	MT-GLAZE 1K JA 1/10W
R1851	401 037 5004	MT-GLAZE 0.000 ZA 1/10W
R1852	401 037 5004	MT-GLAZE 0.000 ZA 1/10W
R1901	401 037 5004	MT-GLAZE 0.000 ZA 1/10W
R1911	401 038 7601	MT-GLAZE 560 JA 1/10W
R1912	401 038 7601	MT-GLAZE 560 JA 1/10W
R1913	401 038 7601	MT-GLAZE 560 JA 1/10W
R1914	401 035 4108	MT-GLAZE 0.000 ZA 1/8W
R1921	401 037 5707	MT-GLAZE 100K JA 1/10W
R1922	401 037 5608	MT-GLAZE 10K JA 1/10W
R1927	401 038 6604	MT-GLAZE 470K JA 1/10W
R1928	401 037 5707	MT-GLAZE 100K JA 1/10W
R1929	401 037 5707	MT-GLAZE 100K JA 1/10W
R1941	401 038 3405	MT-GLAZE 33 JA 1/10W
R1942	401 038 3405	MT-GLAZE 33 JA 1/10W
R1943	401 038 3405	MT-GLAZE 33 JA 1/10W
R1944	401 038 3405	MT-GLAZE 33 JA 1/10W
R1945	401 038 3405	MT-GLAZE 33 JA 1/10W
R1947	401 038 0503	MT-GLAZE 22 JA 1/10W
R1950	401 037 5608	MT-GLAZE 10K JA 1/10W
R1951	401 037 5004	MT-GLAZE 0.000 ZA 1/10W
R1952	401 037 5004	MT-GLAZE 0.000 ZA 1/10W
R1981	401 035 4108	MT-GLAZE 0.000 ZA 1/8W
R1982	401 035 4108	MT-GLAZE 0.000 ZA 1/8W
R1991	401 037 5707	MT-GLAZE 100K JA 1/10W
S1501	645 024 0775	SWITCH,PUSH
S1502	645 024 0775	SWITCH,PUSH
S1503	645 024 0775	SWITCH,PUSH
S1504	645 024 0775	SWITCH,PUSH
S1505	645 024 0775	SWITCH,PUSH
S1506	645 024 0775	SWITCH,PUSH
S1507	645 024 0775	SWITCH,PUSH
S1511	645 008 8728	SWITCH,SLIDE 1P-2T
S1513	614 230 8578	SWITCH,PUSH
S1921	645 009 5795	SWITCH,SLIDE 2P-3T
VR131	645 013 4449	VR,SEMI,22K S
VR132	645 013 4470	VR,SEMI,47K S
VR191	645 024 0782	VR,ROTARY 10KBX2
X1501	614 215 5561	RESONATOR,CERAM
or	645 013 7532	OSC,CERAMIC 4.19MHZ
X1901	645 017 0157	OSC,CERAMIC 16.93MHZ

M3 MECHANISM (CD542AAA-SN/SH)

REF.NO.	PART NO.	DESCRIPTION
101	645 025 3034	ASSY,MD,CHASSIS & SPINDLE
102	645 025 6660	SCREW M2X2.5,SLED-M FIX
103	645 025 3058	GEAR BN,SLED GEAR
104	645 025 3027	ASSY,SLED MOTOR,SLED MOTOR
105	645 025 3041	ASSY,SLED SCREW,SLED
106	645 025 6677	SCREW M1.7X2,SPRING FIX
107	645 025 3072	GEAR BN,RACK SPRING
108	645 025 3065	HOLDER,SLED GEAR HOLDER
109	645 025 6684	TAPPING SCREW B2X8,HOLDER FIX

IC BLOCK DIAGRAM & DESCRIPTION

IC191 SM5877AM

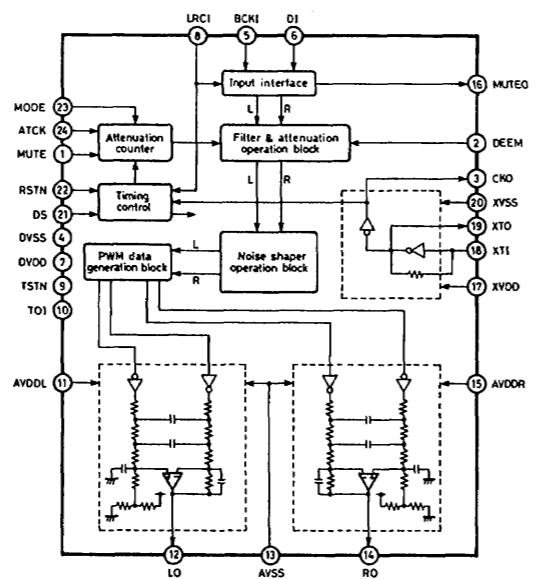

A1501 LCD Display

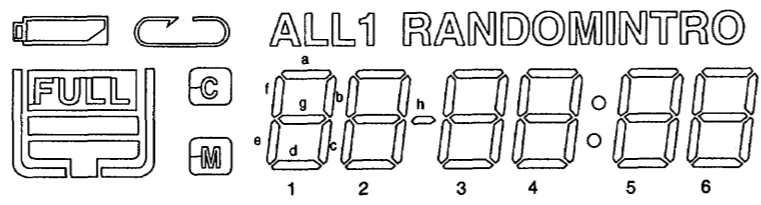
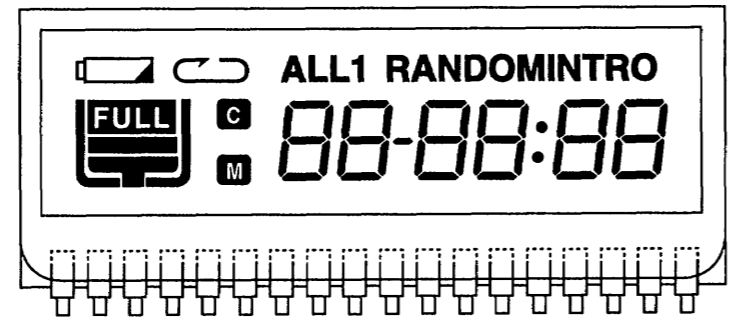

No.	COM.0	COM.1	COM.2	COM.3
1	COM0			
2		COM1		
3			COM2	
4				COM3
5	6a	6b	6c	6d
6	INTRO	6f	6g	6e
7	5a	5b	5c	5d
8	:	5f	5g	5e
9	4a	4b	4c	4d
10	RANDOM	4f	4g	4e
11	3a	3b	3c	3d
12	3h	3f	3g	3e
13	2a	2b	2c	2d
14	C	2f	2g	2e
15	1a	1b	1c	1d
16	FULL	1f	1g	1e
17	1	ALL	↺	M
18	—	—	LJ	↻

WIRING CONNECTION

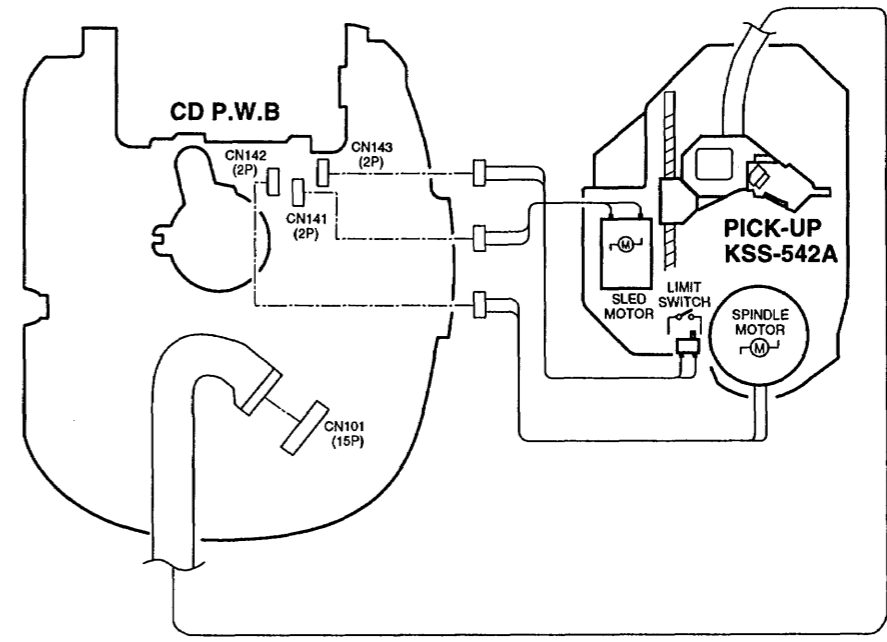

SCHEMATIC DIAGRAM

CDP-360BX/SS, CDP-360CR/UK, CDP-360CR/CA, CDP-360CR/AU, CDP-360E/CA, CDP-370/UK, CDP-360/XE, CDP-360/AU

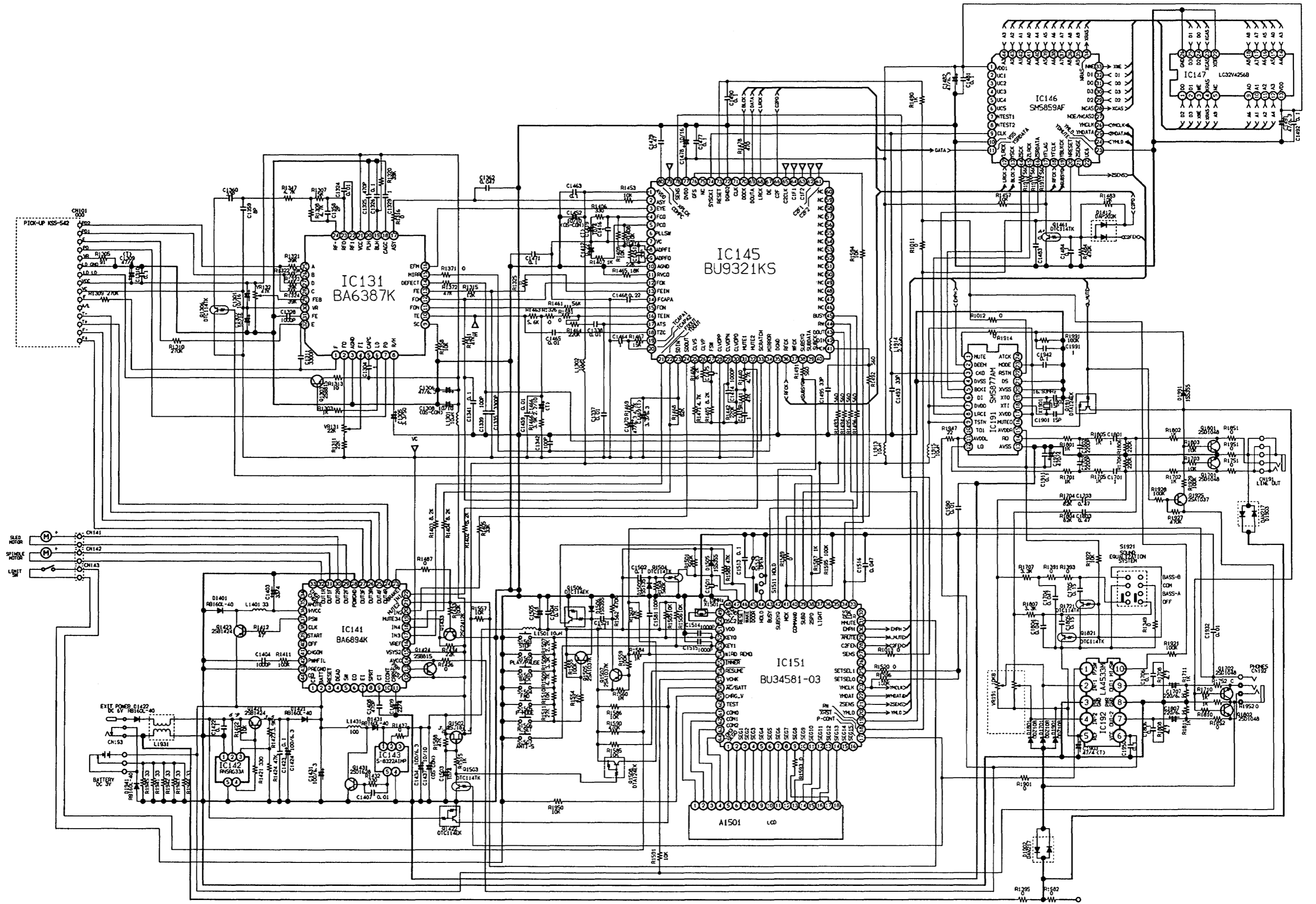

SCHEMATIC DIAGRAM

CDP-640CR/CA, CDP-560/UK, CDP-400CR/UK, CDP-400/XE

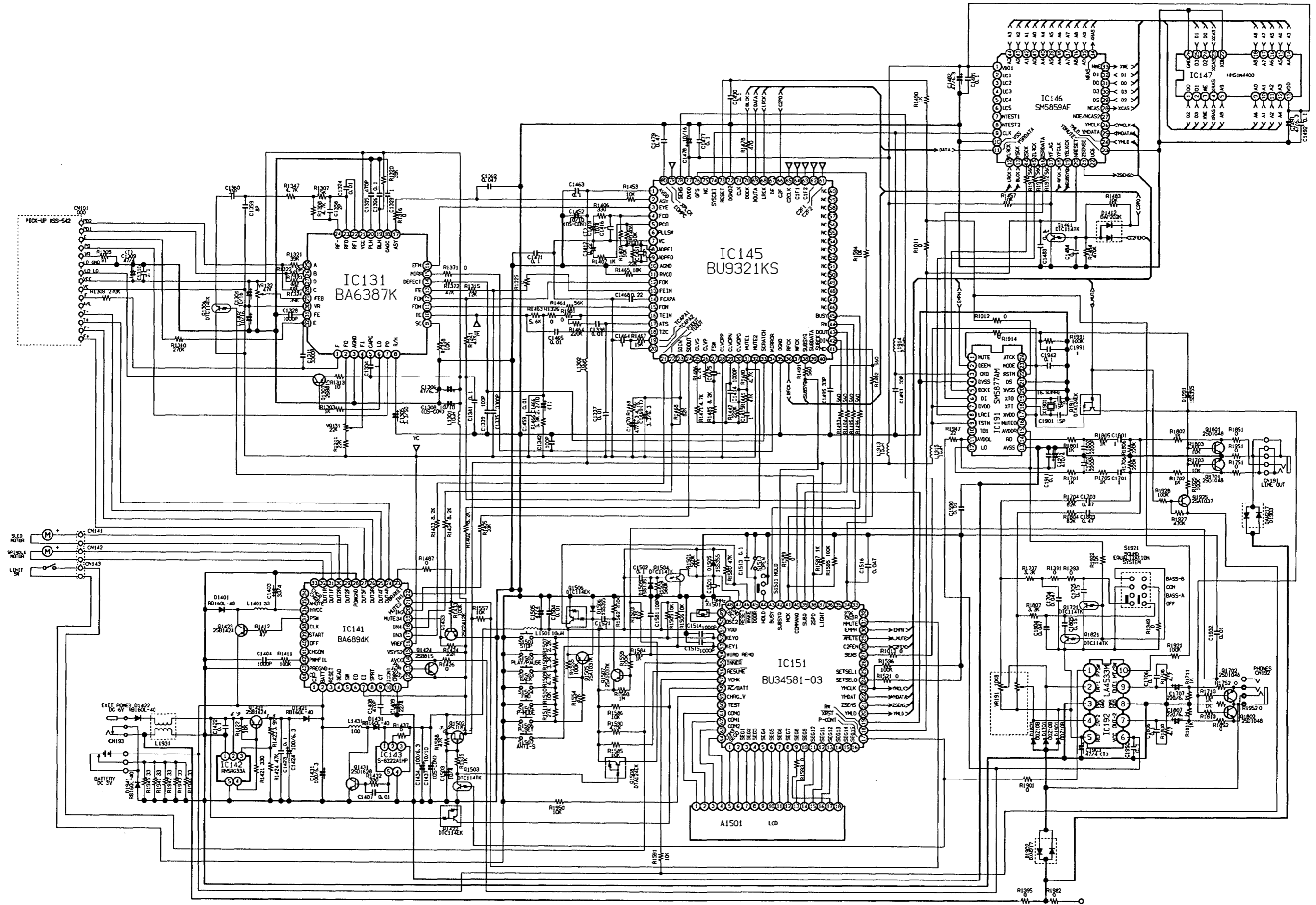

BOTTOM VIEW



TOP VIEW

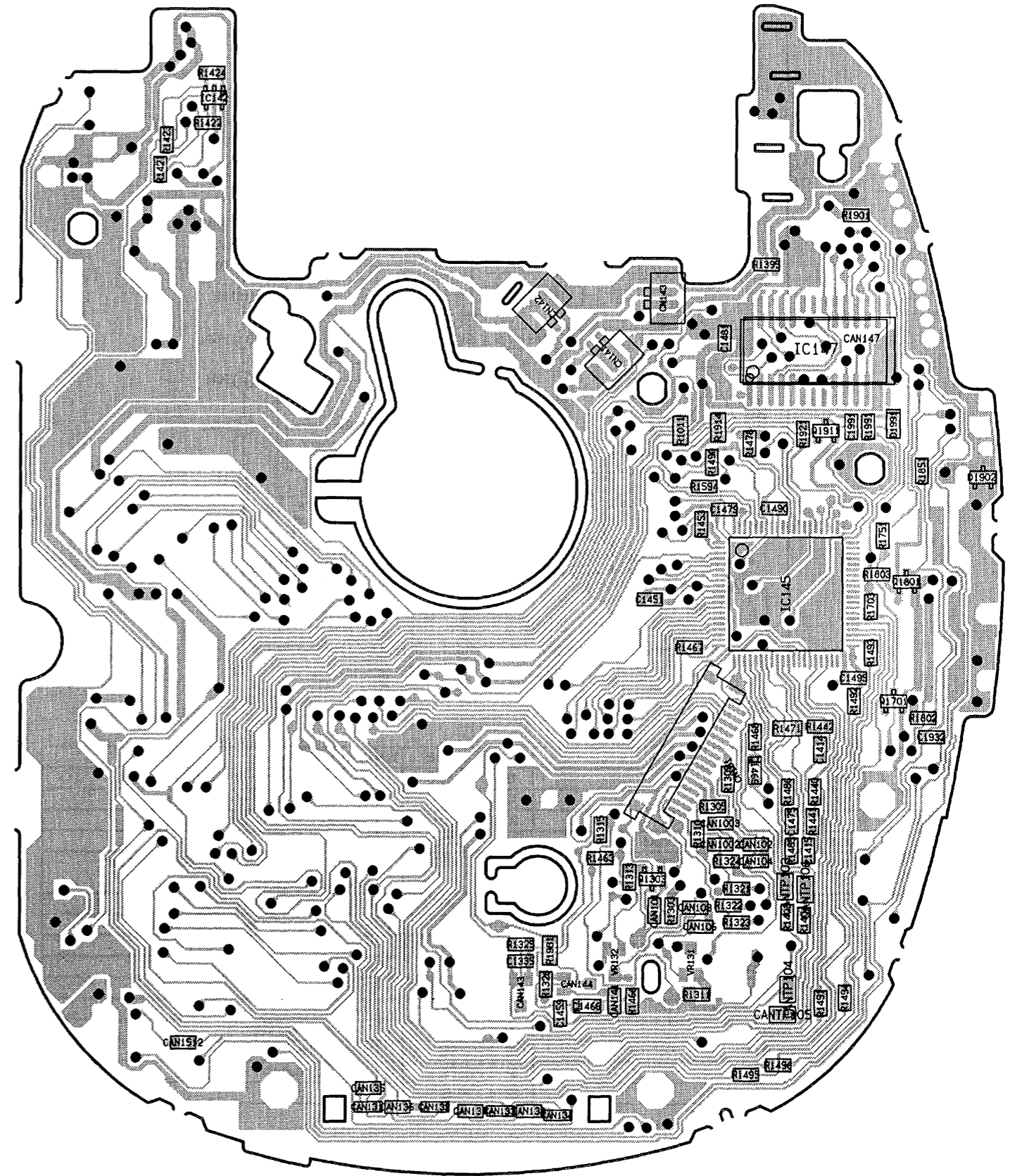

IC BLOCK DIAGRAM & DESCRIPTION

IC131 BA6387K

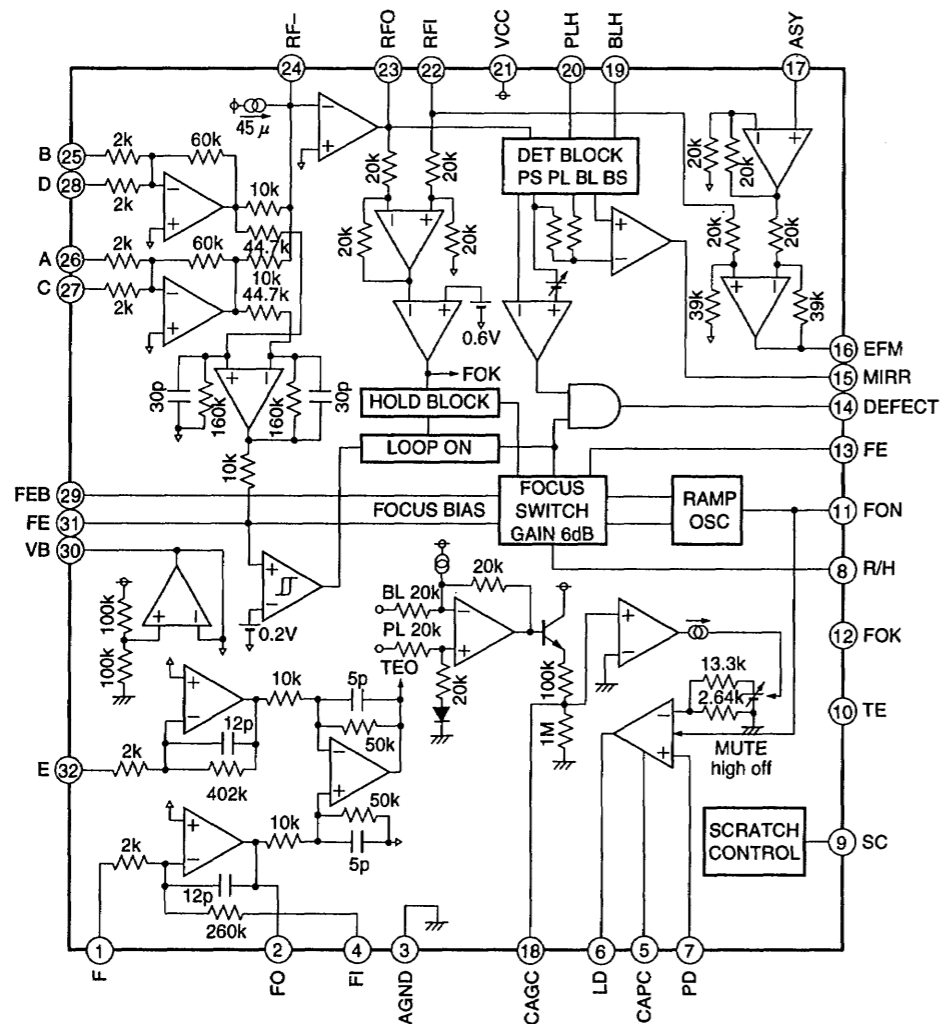

NO.	NAME	I/O	DESCRIPTION	NO.	NAME	I/O	DESCRIPTION
1	F	I	F input.	18	CAGC	I	Capacitor connection of AGC time constant.
2	FO	O	F output.	19	BLH	I	Capacitor connection of bottom long.
3	AGND	-	Analog GND.	20	PLH	I	Capacitor connection of peak long.
4	FI	I	Focus gain adjustment feedback input.	21	VCC	-	Power supply.
5	CAPC	I	Capacitor connection of APC phase compensation.	22	RFI	I	Input for the RF summing amplifier output with capacitance coupled.
6	LD	O	APC amplifier output.	23	RFO	O	RF summing amplifier output.
7	PD	I	APC amplifier input.	24	RF-	I	RF summing amplifier feedback input.
8	R/H	I	Capacitor connection of lamp waveform/loop off.	25	B	I	B input.
9	SC	I	Resistor connection of scratch depth adjustment.	26	A	I	A input.
10	TE	O	Tracking error output.	27	C	I	C input.
11	FON	I	Focus ON control input.	28	D	I	D input.
12	FOK	O	Focus OK comparator output.	29	FEB	I	Focus error bias input.
13	FE	O	Focus error output1.	30	VB	O	Bias amplifier output.
14	DEFECT	O	Defect signal output.	31	FE'	O	Focus error output2.
15	MIRR	O	Mirror signal output.	32	E	I	E input.
16	EFM	O	EFM signal output.				
17	ASY	I	Auto asymmetry control input.				

IC BLOCK DIAGRAM & DESCRIPTION

IC141 BA6894K

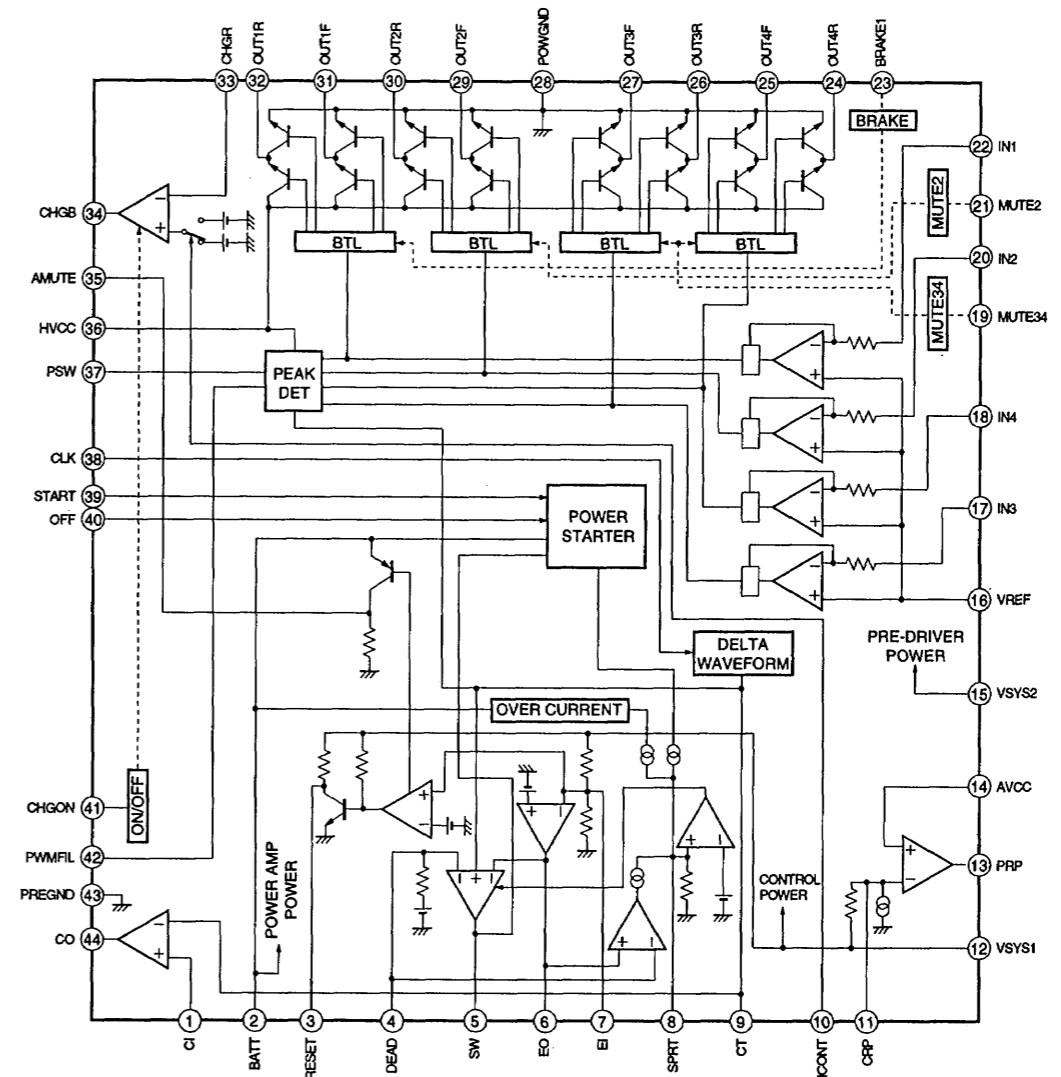

NO.	NAME	I/O	DESCRIPTION	NO.	NAME	I/O	DESCRIPTION
1	CI	I	PWM comparator input.	23	BRAKE1	I	CH1 brake input.
2	BATT	I	Battery detect input.	24	OUT4R	O	CH4 reversed output.
3	RESET	O	Reset detect output.	25	OUT4F	O	CH4 positive output.
4	DEAD	I	Dead time establishment.	26	OUT3R	O	CH3 reversed output.
5	SW	O	Boost transistor drive output.	27	OUT3F	O	CH3 positive output.
6	EO	O	Error amplifier output.	28	POWGND	-	Power GND.
7	EI	I	Error amplifier input.	29	OUT2F	O	CH2 positive output.
8	SPRT	I	Short protect establishment.	30	OUT2R	O	CH2 reversed output.
9	CT	O	Delta waveform output.	31	OUT1F	O	CH1 positive output.
10	ICONT	I	Charge current switching input.	32	OUT1R	O	CH1 reversed output.
11	CRP	I	Ripple filter smoothing input.	33	CHGR	I	Charge current
12	VSYS1	-	Control circuit power supply.	34	CHGB	O	Transistor drive for
13	PRP	O	Transistor drive for ripple filter.	35	AMUTE	O	Reset inversion output.
14	AVCC	O	Ripple filter output.	36	HVCC	-	H brige power supply.
15	VSYS2	-	Pre driver power supply.	37	PSW	O	PWM transistor drive.
16	VREF	I	Reference voltage input.	38	CLK	I	External clock
17	IN3	I	CH3 control signal input.	39	START	I	DC/DC converter boost
18	IN4	I	CH4 control signal input.	40	OFF	I	DC/DC converter boost
19	MUTE34	I	CH3, CH4 mute input.	41	CHGON	I	Charge circuit mute.
20	IN2	I	CH2 control signal input.	42	PWMFIL	O	PWM phase
21	MUTE2	I	CH2 mute input.	43	PREGND	-	PRE GND.
22	IN1	I	CH1 control signal input.	44	CO	O	PWM comparator

IC BLOCK DIAGRAM & DESCRIPTION

IC142 RN5RG33A (Regulator)

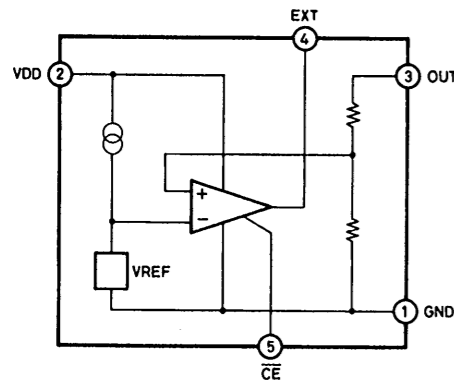

IC143 S-8322AIMP-DOI

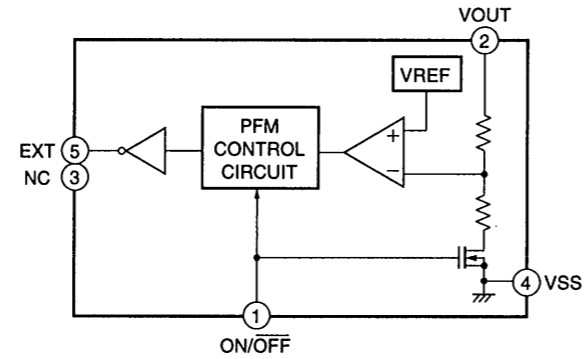

IC147 LC32V4256BM

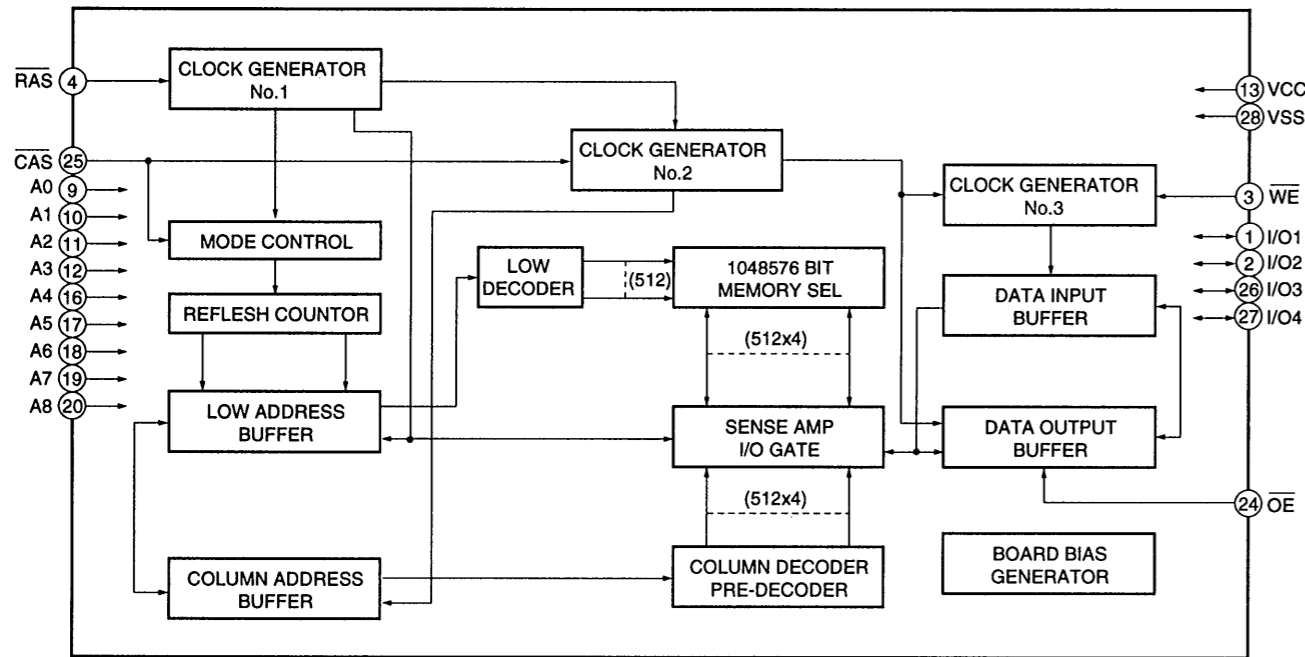

IC192 LA4533M

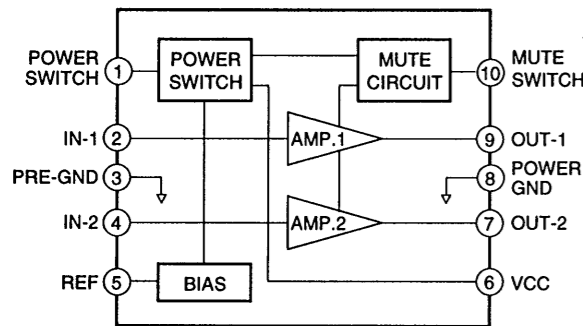

IC BLOCK DIAGRAM & DESCRIPTION

IC145 BU9321KS

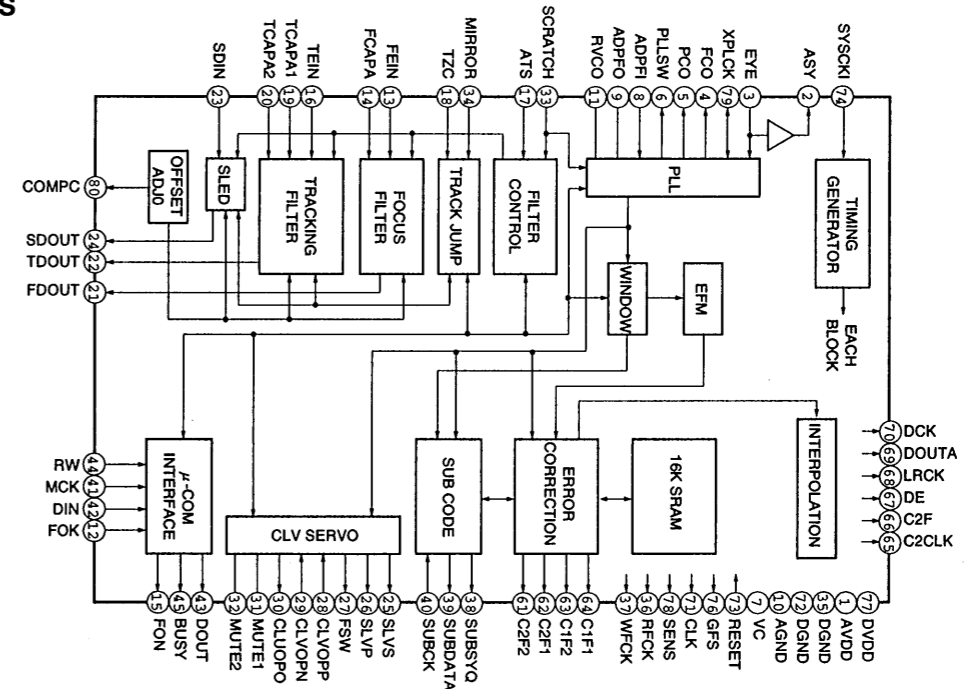

NO.	NAME	I/O	DESCRIPTION	NO.	NAME	I/O	DESCRIPTION
1	AVDD	-	Analog power supply	41	MCK	I	Command reading, sub-code reading clock input
2	ASY	O	EFM signal slice level control output	42	DIN	I	Command serial input from microcomputer
3	EYE	I	EFM signal input from the RF amplifier	43	DOUT	O	Sub Q code serial output
4	FCO	O	PLL frequency comparator output.	44	RW	O	Read/write switching input
5	PCO	O	PLL phase comparison error voltage output.	45	BUSY	O	BUSY output (L: During track jump)
6	PLLSW	O	PLL time constant selection	46	N.C.	-	Not used.
7	VC	I	Bias voltage input	47	N.C.	-	Not used.
8	ADPFI	I	PLL adding amplifier inversion input	48	N.C.	-	Not used.
9	ADPFO	O	PLL adding amplifier output	49	N.C.	-	Not used.
10	AGND	I	Analog GND	50	N.C.	-	Not used.
11	RVCO	I	PLL VCO oscillation frequency adjustment	51	N.C.	-	Not used.
12	FOK	I	Focus OK signal input	52	N.C.	-	Not used.
13	FEIN	I	Focus error signal input	53	N.C.	-	Not used.
14	FCAPA	O	Focus servo filter capacitor connection	54	N.C.	-	Not used.
15	FON	O	Focus ON signal output	55	N.C.	-	Not used.
16	TEIN	I	Tracking error signal input	56	N.C.	-	Not used.
17	ATS	I	Anti-shock detection wind comparator input	57	N.C.	-	Not used.
18	TZC	I	Tracking zero-cross comparator input	58	N.C.	-	Not used.
19	TCAPA1	O	Tracking servo filter switch connection	59	N.C.	-	Not used.
20	TCAPA2	O	Tracking servo filter switch connection	60	N.C.	-	Not used.
21	FDO	O	Focus drive output	61	C2F2	O	C22 correction flag output
22	TDOUT	O	Tracking drive output	62	C2F1	O	C21 correction flag output
23	SDIN	I	Sled amplifier input	63	C1F2	O	C12 correction flag output
24	SDOUT	O	Sled drive output	64	C1F1	O	C11 correction flag output
25	CLVS	O	CLV speed control output	65	C2CLK	O	Strobe signal (f=176.4 kHz)
26	CLVP	O	CLV phase control input	66	C2F	O	Corrected condition output
27	FSW	O	CLV filter time constant selection	67	DE	O	Strobe signal (f=88.2 kHz)
28	CLVOPP	I	CLV adding amplifier non-inversion input	68	LRCK	O	Strobe signal (f=44.1 kHz)
29	CLVOPN	I	CLV adding amplifier inversion input	69	DOUTA	O	Audio data output (2's compliment)
30	CLVOPO	O	CLV adding amplifier output	70	DOCK	O	DOUTA bit clock (f=2.1168 MHz)
31	MUTE1	I/O	CLV mute switch 1	71	CLK	O	Clock output (4 types can be selected by &hE4 command.)
32	MUTE2	I/O	CLV mute switch 2	72	DGND	-	Digital GND
33	SCRATCH	I	Scratch signal input	73	RESET	I	Internal circuit reset
34	MIRROR	I	Mirror signal input	74	SYSCKI	I	System clock input (f=16.93 MHz)
35	DGND	-	Digital GND	75	N.C.	-	Not used.
36	RFCK	O	Read frame clock output	76	GFS	O	GFS monitor output (4 types can be selected by &hE4 command.)
37	WFCK	O	Write frame clock output	77	DVDD	-	Digital power supply
38	SUBSYQ	O	Sub-code sync signal S1 output	78	SENS	O	Monitor output (&hE4 command setting or offset comparator output)
39	SUBDATA	O	Sub-code serial output	79	XPLCK	I/O	PLL playback clock output or external PLL playback clock input
40	SUBCK	I	Sub-code reading clock input	80	COMPC	O	Offset adjustment smoothing (Analog offset measurement enable)

IC BLOCK DIAGRAM & DESCRIPTION

IC151 BU34581 03

NO.	NAME	VO	DESCRIPTION	NO.	NAME	VO	DESCRIPTION
1	SEG0	O	LCD segment output.	33	FOK	I	Connection of DSP, BA6376K.
2	SEG1	O	LCD segment output.	34	GFS	I	Connection of DSP.
3	SEG2	O	LCD segment output.	35	-	-	N.C. (Open)
4	SEG3	O	LCD segment output.	36	-	-	N.C. (Open)
5	SEG4	O	LCD segment output.	37	LIGHT	O	Back light lighting output. (H : lighting)
6	SEG5	O	LCD segment output.	38	2SPD	O	High speed Hi output.
7	SEG6	O	LCD segment output.	39	SUB-Q	I	Connection of DSP (BU9317) DIN.
8	SEG7	O	LCD segment output.	40	COMMAND	O	Connection of DSP (BU9317) DIN.
9	SEG8	O	LCD segment output.	41	MCK	O	Connection of DSP (BU9317) MCK.
10	SEG9	O	LCD segment output.	42	SUBSYQ	I	Connection of DSP (BU9317) .
11	SEG10	O	LCD segment output.	43	BUSY	I	Connection of DSP (BU9317) .
12	SEG11	O	LCD segment output.	44	HOLD	I	HOLD SW input. (H : Hold)
13	SEG12	O	LCD segment output.	45	LID SW	I	Lid sw detect input. (H : Open)
14	SEG13	O	LCD segment output.	46	WAKE-UP	I	Stop mode release detect input. (L : Detect)
15	SEG14	O	LCD segment output.	47	RESET	I	Mi-con reset input.
16	SEG15	O	LCD segment output.	48	GND	-	Mi-con GND.
17	P CON	O	Power control output. (H : ON)	49	OSC1	I	Xtal input.
18	XRESET	O	DSP, ESP reset output. (L : Reset)	50	OSC2	O	Xtal output.
19	RW	O	Connection of DSP.	51	VDD	-	Mi-con power supply.
20	YMLD	O	ESP (SM5856A1F) latch clock output.	52	KEY0	I	Key input.
21	ZSENS	I	ESP (SM5856A1F) status input.	53	KEY1	I	Key input.
22	YMDAT	O	ESP (SM5856A1F) control data output.	54	WREM	I	Wireless remote control key input.
23	YMCLK	O	ESP (SM5856A1F) data clock output.	55	LIMIT	I	LIMIT SW detect input. (L : Detect)
24	SEL 0	I	ESP select input.	56	RESUME	I	RESUME key input. (L : Resume)
25	SEL 1	I	ESP select input.	57	VCHK	I	Power voltage detect input.
26	-	-	N.C. (Open)	58	AC/BATT	I	Power detect input. (L : AC adapter in)
27	SENS	I	DSP SENS signal input.	59	CHRG V	I	Battery charge voltage detect input.
28	C2FEN	O	DSP error detect flag control output.	60	TEST	I	Test input. (For chip test, open)
29	AMUTE	O	Audio mute output. (L : Mute)	61	COM0	O	LCD common output.
30	EMPH	O	Emphasis control. (H : Emphasis on)	62	COM1	O	LCD common output.
31	MMUTE	O	Driver mute output. (H : Mute)	63	COM2	O	LCD common output.
32	IR	I	Wireless remote control input.	64	COM3	O	LCD common output.

IC146 SM5859AF

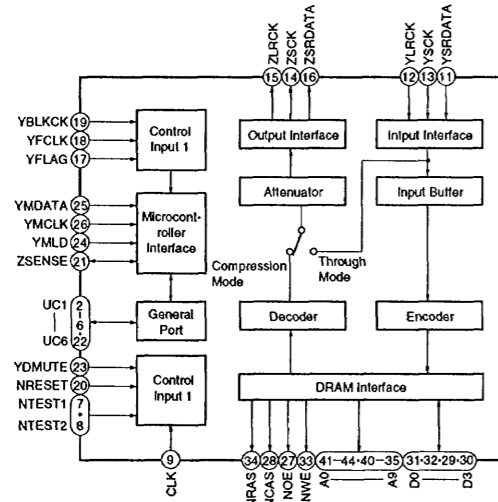

NO.	NAME	VO	DESCRIPTION	NO.	NAME	VO	DESCRIPTION	NO.	NAME	VO	DESCRIPTION
1	VDD	-	Power supply.	16	ZSRDATA	O	Audio serial output data.	30	D3	I/O	DRAM data.
2	UC1	I/O	Micro controller interface expansion.	17	YFLAG	I	RAM overflow flag of signal process IC.	31	D0	I/O	DRAM data.
3	UC2	I/O	Micro controller interface expansion.	18	YFCLK	I	Crystal frame clock.	32	D1	I/O	DRAM data.
4	UC3	I/O	Micro controller interface expansion.	19	YBLKCK	I	Sub code block clock signal.	33	NWE	O	DRAM WE control.
5	UC4	I/O	Micro controller interface expansion.	20	NRESET	I	Reset.	34	NRAS	O	DRAM RAS control.
6	UC5	I/O	Micro controller interface expansion.	21	ZSENSE	I	Micro controller interface status output.	35	A9	O	DRAM address.
7	NTEST1	I	Test terminal.	22	UC6	I/O	Micro controller interface expansion.	36	A8	O	DRAM address.
8	NTEST2	I	Test terminal.	23	YDMUTE	I	Forced mute terminal.	37	A7	O	DRAM address.
9	CLK	I	16.9344MHz clock input.	24	YMLD	I	Micro controller interface latch clock.	38	A6	O	DRAM address.
10	VSS	-	Ground.	25	YMDATA	I	Micro controller interface serial data.	39	A5	O	DRAM address.
11	YSRDATA	I	Audio serial input data.	26	YMCLK	I	Micro controller interface shift clock.	40	A4	O	DRAM address.
12	YLCK	I	Audio serial input LR clock.	27	NOE	O	DRAM OE control (DRAM=1) (NCAS2) DRAM2 CAS control (DRAM=2)	41	A0	O	DRAM address.
13	YSCK	I	Audio serial input bit clock.	28	NCAS	O	DRAM CAS control.	42	A1	O	DRAM address.
14	ZSCK	O	Audio serial output bit clock.	29	D2	I/O	DRAM data.	43	A2	O	DRAM address.
15	ZLRCK	O	Audio serial output LR clock.					44	A3	O	DRAM address.

For Parts or Service Contact
SANYO FISHER SERVICE CORPORATION.
50 Beth Neilson Drive, Tronto, Ontario, M4H 1M6.