

Service Manual

CD Stereo Sound System DC X900 (AU)

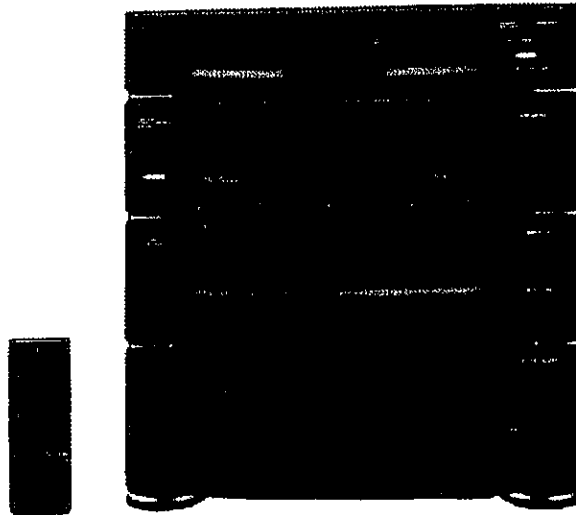

Specifications

Tuner section	
Frequency range	FM : 87.5 - 108 MHz AM : 522 - 1611 kHz
Amplifier section	
Cassette deck section	
Recording system	AC bias, 4-track, stereo
Fast forward / rewind time	Approx. 120 sec. (C-60)
CD player	
Channels	2-channel stereo
Frequency response	20 - 20,000 Hz
Signal to noise ratio	95 dB
Channel separation	90 dB (1 kHz)
Total harmonic distortion	0.13% (1 kHz)
Wow and flutter	Undetectable

Specification subject to change without notice.

PRODUCT CODE No.
129 353 10

General	
Output power	Max. 30 W x 2 (at 8 ohms, 10% distortion)
Input	PHONO : 5mV / 47k ohms VIDEO : 280mV / 47k ohms
Output	SPEAKERS : 8 ohms HEADPHONES : 8 ohms
Power requirements	AC : 240V, 50HZ
Dimensions (approx.)	360 (W) x 328 (D) x 390 (H) mm
RB-X900 remote controller	
Power source	DC : 3 V "AA/SUM-3/R6" battery, x 2
Dimensions (approx.)	63 (W) x 18 (D) x 175 (H) mm

"Dolby" and the double-D symbol  are trademark of Dolby Laboratories Licensing Corporation. Dolby Noise Reduction system is manufactured under license from Dolby Laboratories Licensing Corporation.

REFERENCE No. SM580036

LASER BEAM SAFETY PRECAUTIONS

Do not look directly at the laser beam coming from the pick-up or allow it to strike against your fingers, skin, etc.
Do not apply power if there is a broken part in the laser output section of the pick-up.

Structural Safety Interlock

This model has a disc chuck lever and top lid. This disc chuck lever and top lid prevent to expose the laser beam for users.

INVISIBLE LASER RADIATION EXPOSURE TO BEAM IS DANGEROUS CLASS 1 LASER PRODUCT
OUTPUT POWER : 0.6 mW MAX WAVELENGTH : 790 nm

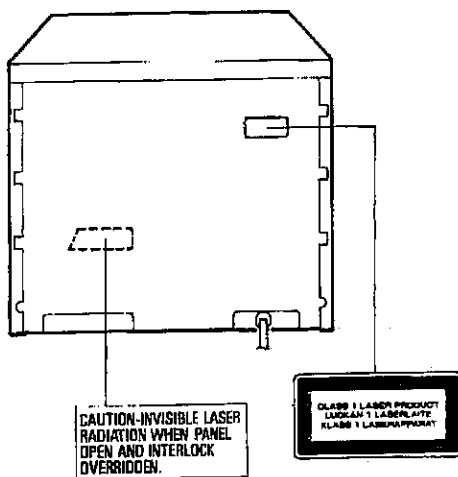

CAUTION - USE OF CONTROLS OR ADJUSTMENTS OR PERFORMANCE OF PROCEDURES OTHER THAN THOSE SPECIFIED IN THE OPERATING INSTRUCTIONS MAY RESULT IN HAZARDOUS RADIATION EXPOSURE.

THE COMPACT DISC PLAYER SHOULD NOT BE ADJUSTED OR REPAIRED BY ANYONE EXCEPT PROPERLY QUALIFIED PERSONNEL.

HANDLING THE PICK-UP

1. Shipping and storage cautions

- The pick-up must be stored in a conductive bag until immediately prior to its use.
- Do not drop it or subject it to impacts.

2. Repair cautions

- When handling the pick-up, be careful not to give it undue force or shock by your hands. Otherwise the pick-up may malfunction or the PCB may be cracked.
- The pick-up which has been minutely adjusted before shipment as one part. Never touch and move the adjusting points and setscrews of the pick-up unless otherwise described in the item of adjustment to avoid damage.

- A strong magnet is used in the pick-up.

Do not bring a magnet or other magnetized object near to it.

3. Cleaning the lens

* If dust gets on the lens, clean it away by using an air brush such as used for a camera lens.

* The lens is held in place by a spring.

If the center of the lens is dirty, carefully clean it using cotton swab moistened with isopropylalcohol. Since special coating is made on the surface of the lens which is made of plastics, do not use other kind of alcohol and cleaning fluid to prevent damage to the lens. Also, be careful not to bend the lens spring when cleaning.

BEFORE REPAIRING THE CD PLAYER

1. Preparations

- Many ICs, LSI and the Pick-up (laser diode) are used in the compact disc player. These components are sensitive to static electricity, and might be damaged by static electricity or high voltage, so particular care should be taken regarding this point.
- Many precision components and the lens are used in the pick-up.
Never attempt to make repairs, or to store parts, where the temperature or humidity is high, where magnetism is strong, or where there is much dust.

2. Notes regarding repairs

- Be sure to first disconnect the power plug before attempting to replace any component.
- All tools, instruments, etc., used for measuring must be grounded.
Grounding can be accomplished by using conductive metal sheet on the work bench.
- To prevent AV leakage of the soldering iron, ground its metal part.
- Repair personnel must be grounded.

DISASSEMBLY (CD MECHANISM)

1. Removal of DISC TRAY

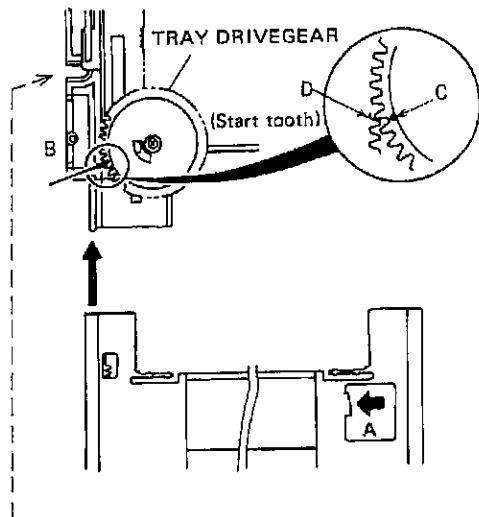

- Drive the mechanism to open end. OPEN / CLOSE Switch : Push ON
- Pull the TRAY off the mechanism. (Push the A rib of the TRAY to the direction of arrow and free from chassis rib.)
- Turn the PICK-UP drive gear (under chucking lever) slowly manual forward clockwise and move the slide to the front end.
- Match the guide groove of TRAY to the chassis guide and insert to the direction of arrow.
- Insert the TRAY to the mechanism after to match the C (tooth bottom) to the D (starting tooth) of TRAY rack. Then complete the close motion by OPEN / CLOSE Switch : Push ON.

Note: Never turn the TRAY drive gear by hand directly in the all mechanism adjustment so that you will wound the teeth of the TRAY drive gear.

(If the left slide obstructs the special screw, turn the PICK-UP drive gear a little.)

2. Removal of CD Mechanism

a. Removal of the chuck lever

Disassembly of the chuck lever
Please use the special driver for the screw (M24).
Refer to the exploded view.

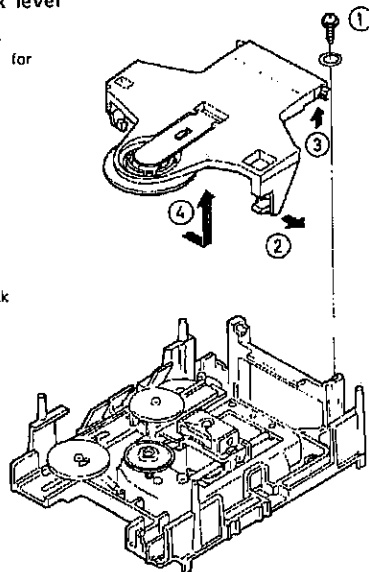

Pull the flange ② of the chuck lever to the outer side.

b. Removal of the sled motor

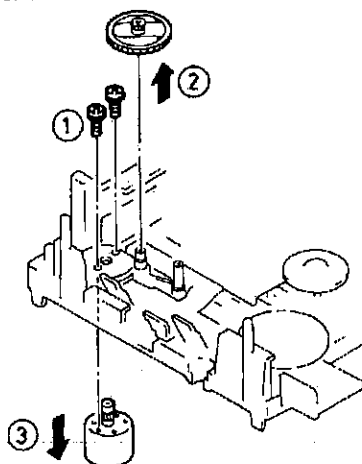

c. Removal of the spindle motor

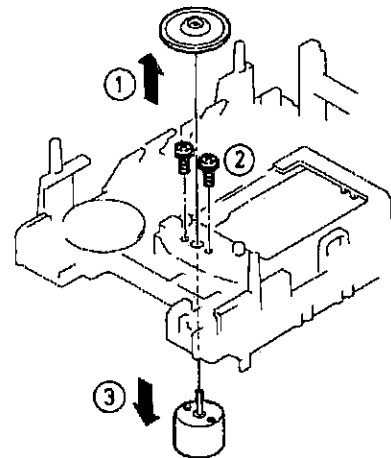

- First, prepare the new turn-table and new special washer for replacement. And prepare dial-type calipers. The removed turn-table will be deformed by the heat of the soldering iron, and cannot be reused.
- a. The attached bonding material can be dissolved by using a 60W soldering iron to heat the shaft at the lower part of the turn-table for about one minute.
- b. The turn-table can then be removed from the shaft by very carefully applying force upward at the center of the lower surface of the turn-table.
- c. Remove the two screw and remove the spindle motor.
- d. Attach the special washer to the spindle motor.
- e. Apply a small amount of a mixture(50 : 50) of the "Three Bond 2001" and "2105F" bonding materials to the motor's shaft.

DISASSEMBLY (CD MECHANISM)

- f. Install the turn-table as shown in the figure.
- g. Secure the turn-table by pressing gently. Be sure to wipe away (by using a piece of cloth, or similar material) any bonding material coming out of the hole.

Don't attached bonding material at the top of shaft

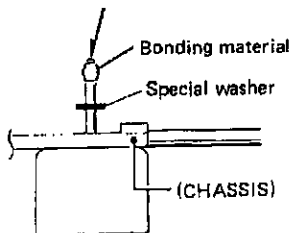

Be sure to wipe away the bonding material

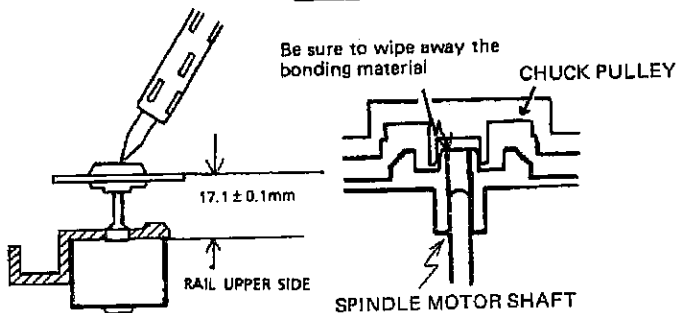

d. Removal of the Pick-up

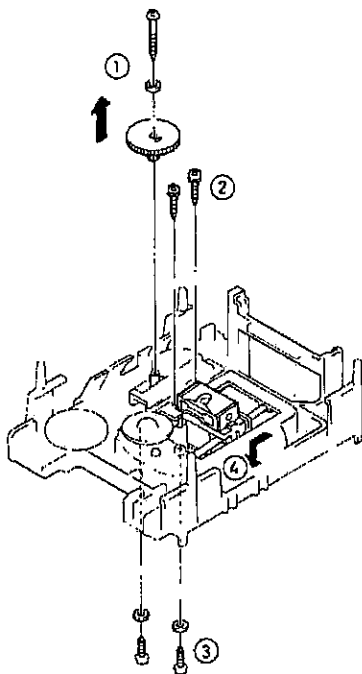

e. Replacement and lubrication of the Pick-up

- a. Before replacement of the pick-up, be sure to carefully read the section regarding the pick-up when the unit is moved or transported.
- b. Remove the two pick-up rails with care fixing the 2 latches with any way driver from bottom of chassis.
- c. When replacing the pick-up, carefully wipe away the grease from the shafts on which the pick-up is mounted.
- d. Replace the pick-up.
- e. Move the pick-up to the position at the left side, and then apply a coating of foil (G-474B) to the shafts.
- f. Move the pick-up to the right side and apply foil to the remaining of the shafts.

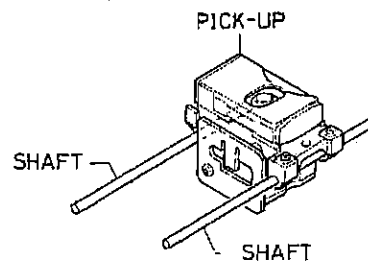

f. Inspection of slip current

Stop the TRAY on opening by force, check the slip mechanism (next gear assembly of motor)

- a. Confirm that the inner gear stops and outer gear and motor's gear rotate.
- b. Confirm that the scale of control meter is 225mV ~ 275mV.
- c. Check this slip inspection on DC 6.0V.

CLUTCH OUTER GEAR PICK DRIVE GEAR

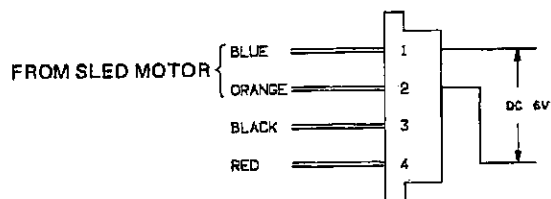
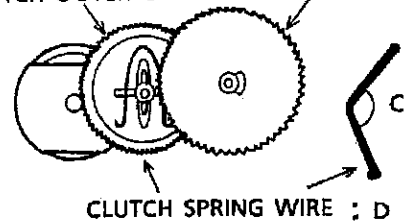

- * In the case of that DC current scale don't display 225mV ~ 275mV, adjust to below items.
 read current value : A · amount of the grease (Silicon G333) :
 B
 bender angle of the spring wire D : C
 A > 275mV → increase the angle C or decrease B.
 A < 225mV → decrease the angle C or increase B.

CD ADJUSTMENT

Electrical Adjustment

So far we have presented explanations regarding compact disc player handling, notes prior to repair, handling the pick-up and disassembly of the unit. Be sure to carefully read these instructions before making any adjustments.

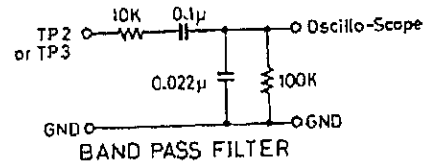

Preparations for Adjustments

Measuring instruments, tools and filter

- (1) Test disc : YEDS 18 (Sony)
- (2) Oscilloscope : SS5711 (10MHz or dual phenomenon) or Memoryscope : DSS6521 (Storagescope)
- (3) Digital voltmeter (Input impedance 1M ohm or more)
- (4) Oscillator (400Hz, 300mV RMS)
- (5) Frequency Counter (5MHz; or more)
- (6) Screw drivers (non-metallic) for adjustments
- (7) Band Pass Filter
- (8) AC Voltage Meter

Notes: a. The adjustments can be using the equipment produced by other manufactures provided that the performance of that equipment corresponds to that of the above listed models.
 b. Use a 10 : 1 probe for observing signals on the oscilloscope and storage scope.
 c. Test disc is subject change without notice.

1. Initial set

Set the SVR11 at its initial position of adjustment controls as shown in figure below.

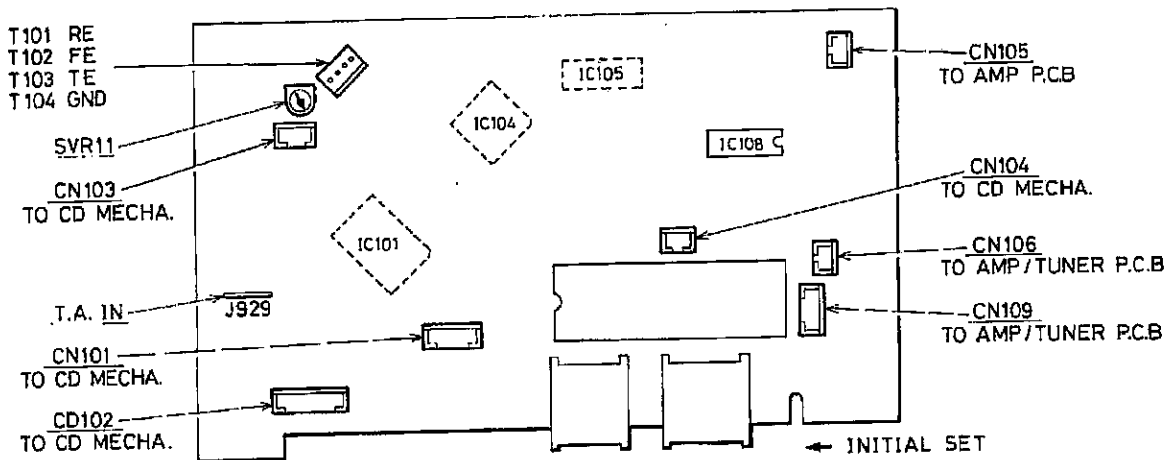

2. Tracking Balance Adjustment (SVR11)

1. Connect the oscilloscope to TP3 (TE) and TP4 (GND).
2. Turn on the power of the unit. Insert test disc.
3. Play-back the test disc.
4. Continuously press the forward search $\blacktriangleright\blacktriangleright$ or $\blacktriangleleft\blacktriangleleft$ button to do it
5. Adjust SVR11 so that the TE (Tracking Error) signal waveform of TP3 on the oscilloscope is vertically symmetrical relative to 0V. (See figure right side)

*If the adjustment is imperfect, become run away the sled motor (pick-up sending motor), inferior playability.

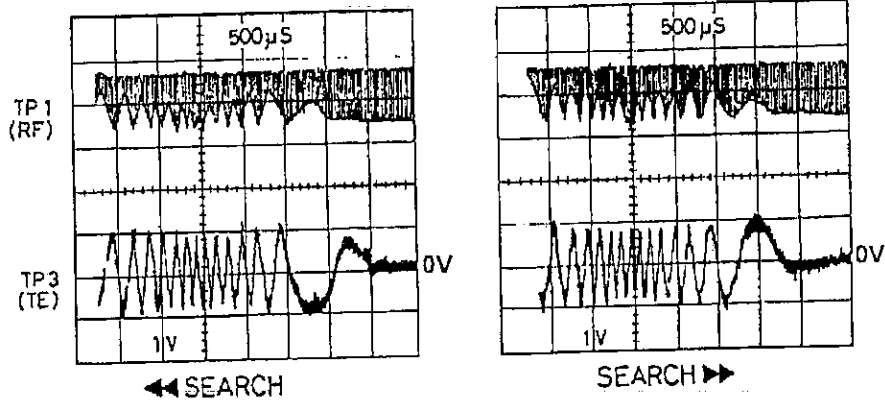

CD ADJUSTMENT

2. Other Adjustment of Tracking Balance (SVR11)

1. Short J929 (A.T.IN) and TP4 (GND) or connect TP23 (T.OFF) to +5V through the resistor : 10k ohms.
2. Connect the oscilloscope to TP3 (TE) and TP4 (GND.).
3. Turn on the power of the unit.
4. Adjust SVR11 so that the TE (Traverse) signal waveform of TP3 during about 12 sec. on the oscilloscope is vertically symmetrical relative to 0V. Or may adjust SVR11 so that the DC voltage : (Peak Hold Level) - (Bottom Hold Level) of the traverse signal is 0V. (See figure right side)
5. If this adjustment is not complete during 12 sec. reperform item 2 ~ 4.

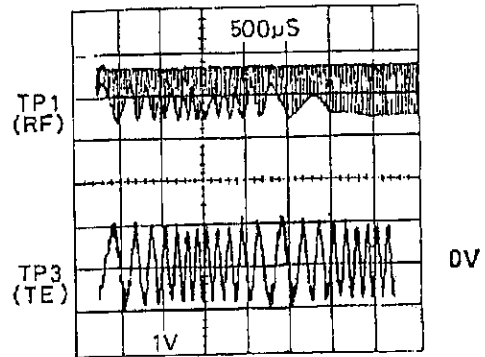

3. Focus Gain Confirmation

1. Connect the storage scope to TP2 (F.E : Focus Error) through the Band pass filter. (See BPF Figure)
2. Turn on the power of the unit.
3. Play-back the test disc.
4. Set the output of AF oscillator to 400Hz, 0.5V rms and connect to TP82 through the resistor : 38k ohms.
5. Confirm so that the voltage of the F.E signal waveform on the storage scope is 0.5V p-p, $\pm 3\text{db}$ by through BPF.

*If this CONFIRMATION is imperfect, become weak the mechanical shock, inferior playability, and can not playback the Disc.

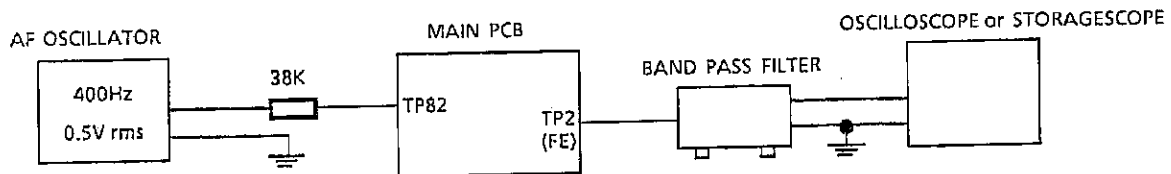

4. Tracking Gain Confirmation

1. Connect the storage scope to TP3 (T.E) through the Band pass filter. (See BPF Figure).
2. Turn on the power of the unit.
3. playback the test disc.
4. Set the output of AF oscillator to 400Hz, 0.5V rms and connect to TP81 through resistor 105k ohms.
5. Confirm so that the voltage of T.E signal waveform on the storage scope is 0.5V p-p, $\pm 3\text{db}$ by through BPF.

*If this CONFIRMATION is imperfect, become weak the mechanical shock, inferior playability, and can not playback the Disc.

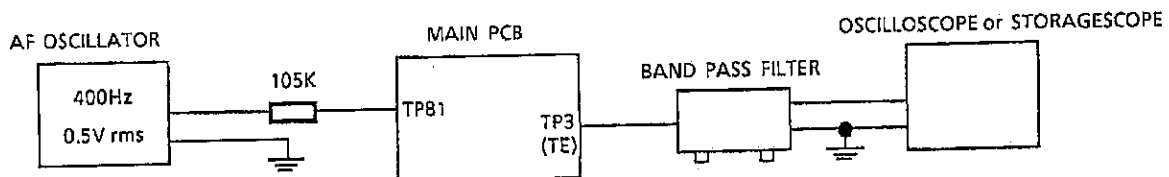

TUNER ADJUSTMENT

- Use a plastic screwdriver for adjustment.
- Adjust the intermediate frequency of AM and FM to the frequency of ceramic filter.

1. FM Band Antenna : 75 ohm Direct Modulation : 1kHz Dev. : ± 40 kHz (Main), ± 6.75 kHz (Pilot)

STEP	ITEMS	FREQUENCY INDICATED POSITION	INPUT CONDITIONS		OUTPUT CONDITIONS		ADJUSTING PARTS	STANDARDS
			MEASURING INSTRUCTIONS	CONNECTIONS	MEASURING INSTRUCTIONS	CONNECTIONS		
1	IF (V Curve)	-----	FM Sweep Generator (10.7MHz Non Modulation Small Input)	TP221(H) TP212(E)	FM Sweep Generator	TP223(H) TP224(E)	T2201	Max. and Symmetrical Wave
2	Tuning Cover	Low	---	---	Digital Voltmeter	TP202(H)	---	1.3 \pm 0.05 V * Confirm voltage is below 8.5V
		High				TP201(E)		
3	Tracking	Low	FM-SG (8dB)	FM ANT TERMINAL	VTVM Oscilloscope	AF Out (L/R,E)	L2102 L2103	Max.
		High					CT201	
4	IF (OV)	98.1 MHz	FM-SG (66dB)	FM ANT TERMINAL	Digital Voltmeter	TP203(H) TP204(E)	T2202	0 \pm 0.05 V
5	VCO (19 kHz)	98.1 MHz	FM-SG (66dB)	FM ANT TERMINAL	Frequency Counter	TP206(H) TP207(E)	SVR23	19 \pm 0.05 kHz

RF Level : 75 ohm, Open SG voltage dB μ V * (about 6.6V)

2. AM Band

Antenna : IRE Loop, , Modulation : 1kHz 30%

STEP	ITEMS	FREQUENCY INDICATED POSITION	INPUT CONDITIONS		OUTPUT CONDITIONS		ADJUSTING PARTS	STANDARDS
			MEASURING INSTRUCTIONS	CONNECTIONS	MEASURING INSTRUCTIONS	CONNECTIONS		
1	Tuning Cover	Low	---	---	Digital Voltmeter	TP202(H)	---	Confirm voltage is 1.2 ~ 1.5V
		High				TP201(E)		* Confirm voltage is below 8.5V

RF Level : Open SG voltage dB μ V * (about 7.2V)

3. Parts Location

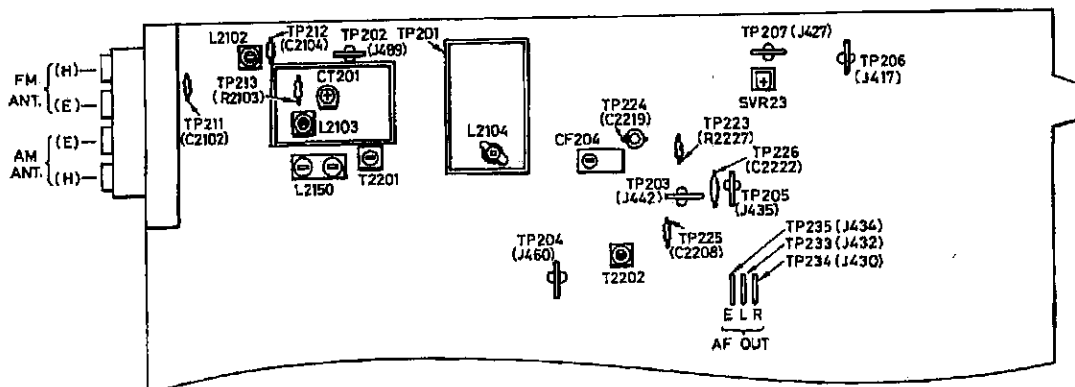

ADJUSTMENT OF DECK & TORQUE

1. Amplifier Adjustment

	ITEM	DECK	TEST TAPE	INPUT	DOLBY SW	OUTPUT	ADJUST	REMARKS
1	Head Azimuth	DECK 1 DECK 2	VTT738	-	OFF	TAPE OUT	Azimuth Screw	Adjust so as 10kHz output become maximum.
2	Playback Level	DECK 1 DECK 2	TCC130	-	OFF	TAPE OUT	SVR30 (L-ch) SVR31 (R-ch) SVR32 (L-ch) SVR33 (R-ch)	Adjust so as TAPE OUT output become 0.54V.
3	Rec/Play Level	DECK 2	AC224	1kHz -18dB	OFF	TAPE OUT	SVR34 (L-ch) SVR35 (R-ch)	Adjust SVR so as Monitor output = R/P Level = 0dB ± 1dB.
4	Rec/Play Frequency	DECK 2	AC224	1kHz /10kHz -28dB	OFF	TAPE OUT	SVR36 (L-ch) SVR37 (R-ch)	R/P signal, set frequency characteristic 1kHz output to 0dB. Adjust SVR so as 10kHz output become ± 1dB.

Note. 1. During alignment, measurement Beat cancel SW is at 1 condition fundamentally, confirm Rec/Play frequency characteristic, dolby effect also by 2 condition, when ship out set SW to 1 position.

2. Tape Speed Adjustment

Connect the FREQUENCY COUNTER to TAPE OUT.

1. Insert the test tape(MTT-111N, etc.: 3000Hz) into the DECK 1.
Note: Set the test tape near the tape end.
2. Press the FWD PLAY button.
3. Adjust SVR001 so that a frequency counter reading of 3000 ± 5 Hz is obtained.
4. Press the STOP button, and eject the test tape.
5. Insert the test tape(TCW-211, etc.: 1500Hz) into the DECK 1.
6. Insert the tape (C-60 Blank tape) into the DECK 2.
7. Press the REC button of DECK 2 and press the DECK 1/2 button.
Press the FWD PLAY button. Both mechanism become normal speed dubbing.
8. Short the high speed test pin to the high speed position.
(The mechanism is high speed dubbing.)
9. Confirm that a frequency counter reading of 2700 ~ 3300Hz is obtained.

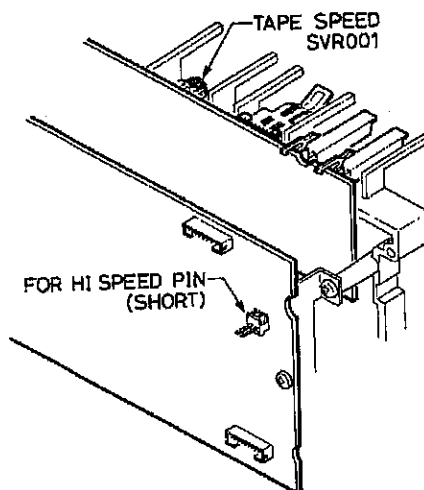

3. Torque Measurements

ITEM	TAKE-UP TORQUE	BACK TENSION	PULLEY TENSION
Test cassette	PLAY : TW2111(FWD) PLAY : TW2121(REV) F.FWD / REW; TW2231	PLAY : TW2111(FWD) PLAY : TW2121(REV) REW: Torque Gage	Driving power cassette: TW-2412(FWD) TW-2422(REV)
PLAY	30 ~ 60gr.cm	2.0 ~ 5.0gr.cm	> 80g
F.FWD	70 ~ 140gr.cm	-	
REW	70 ~ 140gr.cm	-	

4. Parts Location

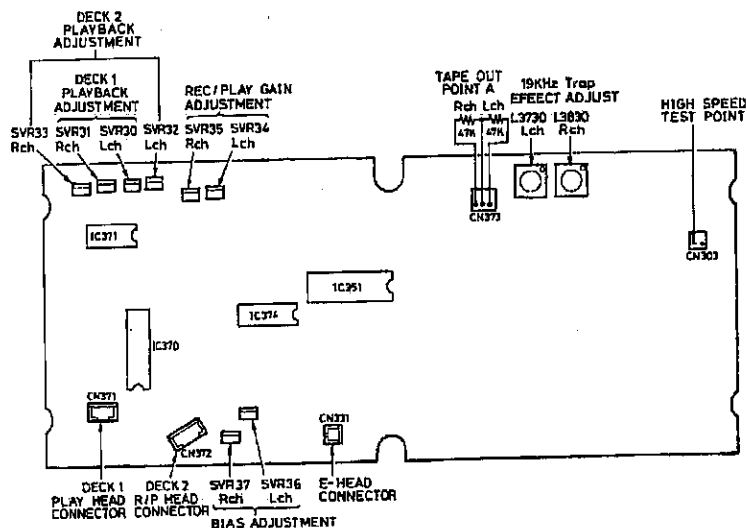

DISASSEMBLY (TAPE MECHANISM)

1. Replacement of Head

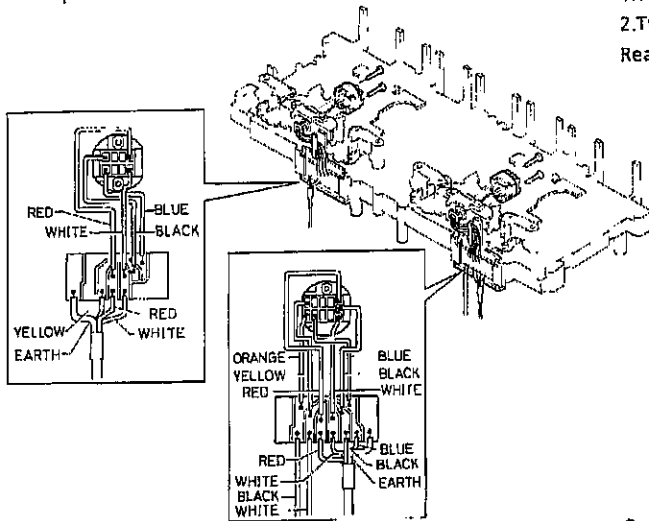

LEAD CONNECTION METHOD OF ROTARY HEAD

1. The root (Bonding parts) of leads from head fix the rubber adhesiver.
 2. Twit (Turn) the fixed Leads.
- Reason : Cut for rotation

2. Replacement of Motor & Belt

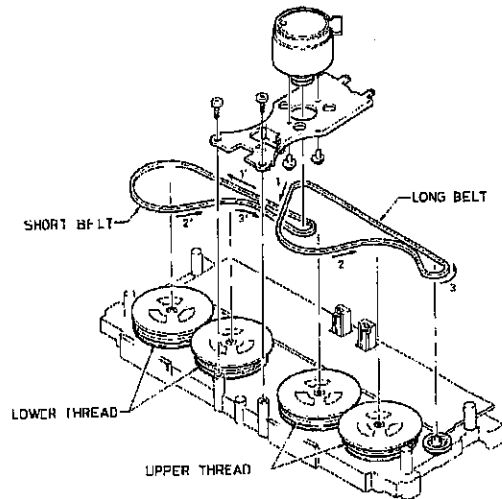

REMOTE CONTROLLER (RB-X900)

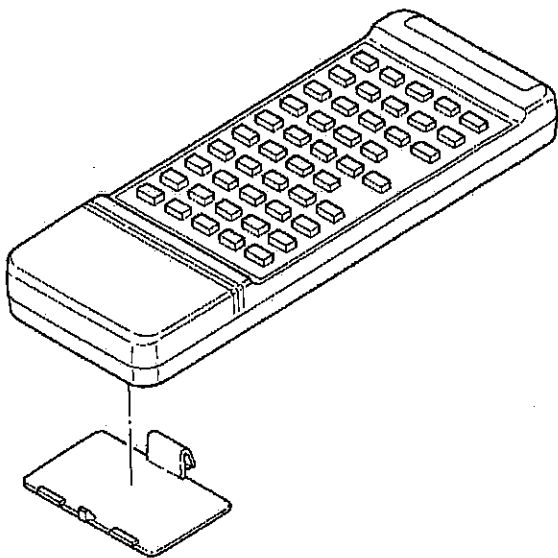

PARTS LIST

REMOTE CONTROLLER (RB-X900)

Ref. No.	Part No.	Description
	614 233 7141	ASSY, REMOCON
	614 231 2087	LID, BATTERY

EXPLODED VIEW (CABINET & CHASSIS)

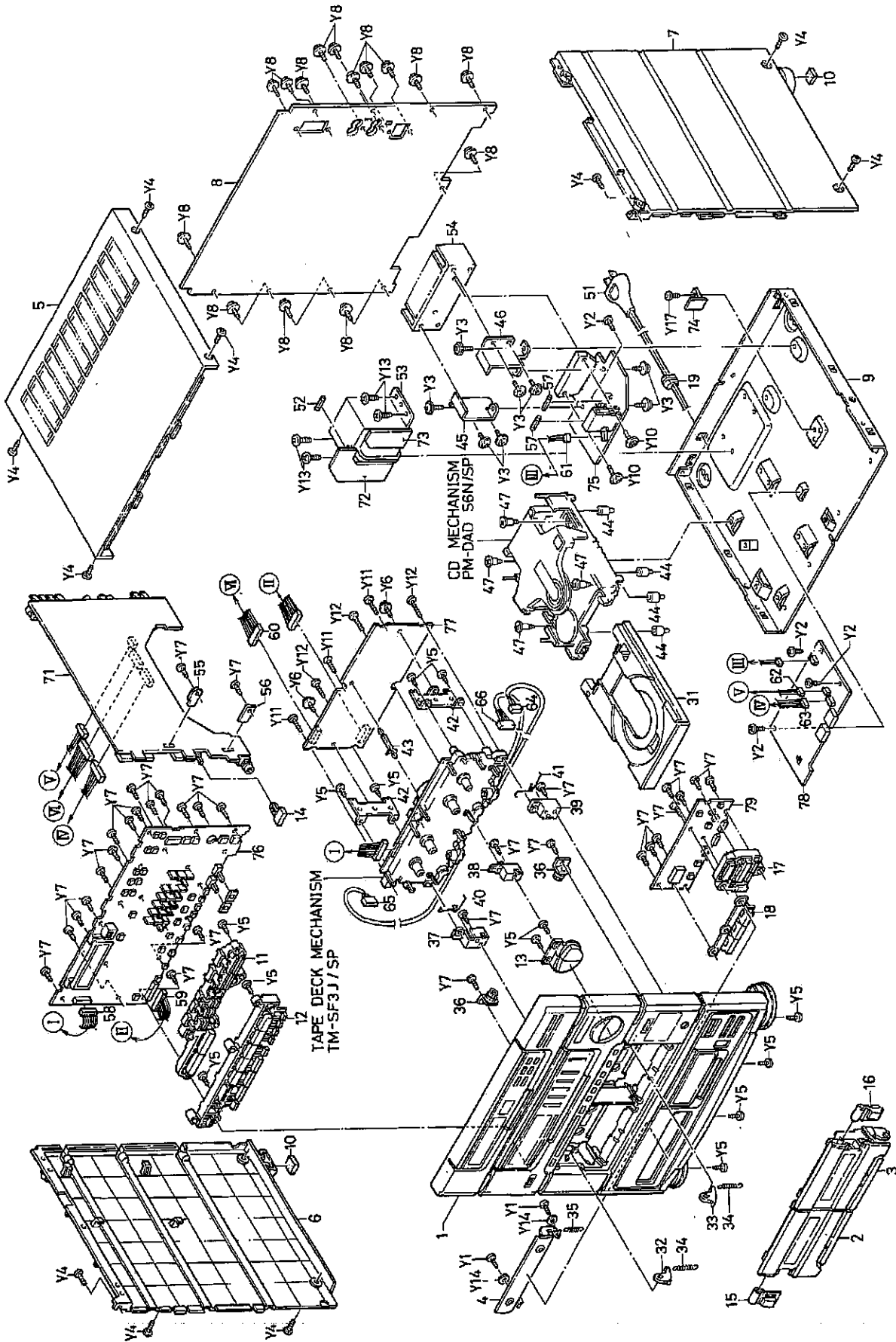

PARTS LIST

PRODUCT SAFETY NOTICE

Each precaution in this manual should be followed during servicing. Components identified with the IEC symbol Δ in the parts list and the schematic diagram designate components in which safety can be of special significance. When replacing a component identified Δ , use only the replacement parts designated, or parts with the same ratings of resistance, wattage or voltage that are designated in the parts list in this manual. Leakage current or resistance measurements must be made to determine that exposed parts are acceptably insulated from the supply circuit before returning the product to the customer.

CAUTION: Regular type resistors and capacitors are not list. To know those values, refer to the schematic diagram.

N.S.P : Not available as service parts.

PACKING & ACCESSORIES

Ref. No.	Part No.	Description
	614 244 8557	INNER CARTON, MALAYSIA
	614 244 8564	INNER CARTON, SINGAPORE
	614 231 4180	PAD, TOP
	614 231 4173	PAD, BOTTOM
	614 180 4651	PROTECTOR SHEET, SET
	614 231 6672	POLY COVER, SET
	614 176 3231	INNER POLYE COVER, INST-B
	614 176 1039	INNER POLYE COVER, SCREW
	614 231 2490	POLY COVER, REMOCON
	614 244 8458	INSTRUCTION MANUAL
	614 231 6832	LABEL, SAFETY, LASER
	614 232 6671	ANTENNA, FM
	614 208 7565	LOOP ANT, AM
	614 212 2341	MOUNT-E, LOOP ANT
	411 083 9307	SCR WOOD RND 3.1X13, AM FNT

CABINET

Ref. No.	Part No.	Description
1	614 228 4421	ASSY, PANEL, FRONT
2	614 227 8253	ASSY, LID, CASSETTE, DECK 1
3	614 229 7995	ASSY, LID, CASSETTE, DECK 2
4	614 228 4667	DOOR, CD TRAY
5	614 228 3981	PANEL, TOP
6	614 228 4001	PANEL, SIDE, L
7	614 228 4018	PANEL, SIDE, R
8	614 244 8274	PANEL, REAR, MALAYSIA
or	614 244 8281	PANEL, REAR, SINGAPORE
9	614 229 8022	CABINET, BOTTOM
10	614 106 4215	STAND, FOOT
11	614 228 4995	BUTTON, TUNER
12	614 231 7488	BUTTON, AMP DECK
13	614 228 4544	BUTTON, VOL
14	614 228 0218	BUTTON, BASS
15	614 227 8338	BUTTON, EJECT L
16	614 227 8345	BUTTON, EJECT R
17	614 228 4032	BUTTON, CD (OPEN/CLOSE)
18	614 228 4551	BUTTON, CD (EDIT)
19	Δ 614 129 1901	FIXER, AC CORD

CHASSIS

Ref. No.	Part No.	Description
31	614 221 1410	TABLE, LOADING, CD TRAY
32	614 221 8983	LEVER, DECK EJECT L
33	614 221 8990	LEVER, DECK EJECT R
34	614 208 9606	SPRING, TENS, EJECT LEVER
35	614 221 0246	SPRING, TENS, CD DOOR
36	614 069 0385	GEAR ASSY, DAMPER
37	614 227 8383	MOUNT-M, DECK L
38	614 227 8390	MOUNT-M, DECK C
39	614 227 8406	MOUNT-M, DECK R
40	614 227 8475	SPRING, WIRE, LID OPEN L
41	614 227 8482	SPRING, WIRE, LID OPEN R
42	614 221 8839	BRACKET-E, DECK PCB FIX

Ref. No.	Part No.	Description
43	614 129 5558	FIXER, DECK PCB FIX
44	614 124 8899	RUBBER CUSHION, CD
45	614 207 3490	BRACKET-E, HEAT SINK FIX
46	614 207 3506	BRACKET-E, HEAT SINK FIX
47	412 004 5705	SPECIAL SCREW, CD
48	614 212 8343	LABEL, SAFETY, LASER

FIXING PARTS

Ref. No.	Part No.	Description
Y1	411 021 2704	SCR S-TPG BIN 2.6X6
Y2	411 021 5705	SCR S-TPG BIN 3X6
Y3	411 020 9803	SCR S-TPG BRZ+FLG 3X6
Y4	411 021 6603	SCR S-TPG BIN 3X8
Y5	411 021 6405	SCR S-TPG BIN 3X8
Y6	411 020 9902	SCR S-TPG BRZ+FLG 3X8
Y7	411 021 3503	SCR S-TPG BIN 3X10
Y8	411 020 8905	SCR S-TPG BRZ+FLG 3X10
Y10	411 020 9506	SCR S-TPG BRZ+FLG 3X16
Y11	411 021 4906	SCR S-TPG BIN 3X20
Y12	411 098 4403	SCR S-TPG BIN 3X25
Y13	411 001 3905	SCR S-TPG BIN 4X6
Y14	411 092 0906	WASHER Z 2.6X10X0.6
Y17	411 001 1901	SCR S-TPG BIN 3X6
Y18	411 085 1903	WASHER OUT TW 3

ELECTRICAL PARTS

Ref. No.	Part No.	Description
51	Δ 614 023 2929	POWER CORD, AC-IN
52	Δ 423 016 9803	FUSE 250V 0.63A, POWER, FU999
53	Δ 614 230 1982	POWER TRANSFORMER (P.T)
54	Δ 614 209 4259	HEAT SINK, FOR IC752
55	614 245 1069	PCB, FIX TUNER/PRE-AMP PCB
56	614 245 1083	PCB, FIX TUNER/PRE-AMP PCB
57	Δ 423 016 7908	FUSE 250V 2.5A, SPEAKER, FU701-801
58	614 231 7280	ASSY, CONNECTOR-S, 8P, FRONT-MECHA, CN001
59	614 231 7273	ASSY, CONNECTOR-S, 8P, FRONT-DECK, CN003
60	614 231 6269	ASSY, CONNECTOR-S, 8P, AMP-DECK LEAD, CN311
61	614 234 5863	ASSY, CONNECTOR-S, 3P, CN120
62	614 234 5870	ASSY, CONNECTOR-S, 3P, CN121
63	614 234 5887	ASSY, CONNECTOR-S, 5P, CN122
64	614 231 2599	ASSY, CONNECTOR-S, 2P, E HEAD, CN341
65	614 231 2575	ASSY, CONNECTOR-S, 4P, P HEAD, CN381
66	614 231 2582	ASSY, CONNECTOR-S, 5P, R/P HEAD, CN382

PARTS LIST

TUNER/PRE-AMPLIFIER P.C.BOARD ASSY

Ref. No.	Part No.	Description	Ref. No.	Part No.	Description
71	614 245 0734	ASSY, PCB, TUNER/PRE-AMP	IC201	409 195 3108	IC LA1265-AUD
	614 116 5349	SHIELD PLATE, SYMBOL SIDE	IC202	409 016 9500	IC LA3361
	614 117 1029	SHIELD PLATE, PATTERN SIDE	IC203	409 066 7600	IC LM7001
C2304	403 080 5000	POLYPRO 1000P J 100V	IC701	409 018 4909	IC LA64585
C2458	403 106 1603	NP-ELECT 1U Q 50V	IC702	409 003 9308	IC BU4051B
CF201	614 231 0199	FILTER, 10.7MHZ, FM	IC703	409 018 4909	IC LA64585
CF202	614 231 0199	FILTER, 10.7MHZ, FM	IC751	409 018 4305	IC LA6458D
CF204	614 211 2939	FILTER, 459KHZ, AM	IC802	409 003 9308	IC BU4051B
CF205	614 030 7443	I.F FILTER, 459KHZ, AM	IC902	409 020 2900	IC LB1439N
CN201	614 220 2029	TERMINAL, 4P, ANT	L2102	614 229 0866	TRANS, RF, FM
CN491	614 227 0011	SOCKET, 10P(B TO B), TO FRONT1	L2103	614 229 0873	TRANS, RF, FM
			L2104	614 035 0036	VHF COIL, TUNING COVER
CN492	614 226 9985	SOCKET, 6P(B TO B), TO FRONT2	L2105	614 028 4058	FILTER, 2.2UH, FM
CN493	614 226 9985	SOCKET, 6P(B TO B), TO FRONT3	L2150	614 228 0294	TUNER, RF, AM COIL UNIT
CN700	614 017 2171	PLUG, 10P, TO DECK	L2451	614 028 4256	FILTER, 100UH, CHOKE
CN701	614 017 2140	PLUG, 7P, TO POWER-AMP	Q2101	405 092 5702	TR 2SK606-Q
CN702	614 017 1440	PLUG, 3P, TP POWER-AMP(AMP3)	or	405 093 7606	TR 2SK606-R
CN703	614 016 8341	PLUG, 2P, TO TURNTABLE	Q2102	405 012 5904	TR 2SC1923-Y
CN705	614 017 2591	PLUG, 8P, TO DECK	Q2103	405 092 5702	TR 2SK606-Q
CN710	614 017 2560	PLUG, 5P, TO CD-MAIN(CD1)	or	405 093 7606	TR 2SK606-R
CN711	614 017 2546	PLUG, 3P, TO CD-MAIN(CD2)	Q2104	405 012 5904	TR 2SC1923-Y
CN730	614 226 9985	SOCKET, 6P(B TO B), TO FRONT4	Q2105	405 012 5904	TR 2SC1923-Y
CN731	614 226 9985	SOCKET, 6P(B TO B), TO FRONT5	Q2201	405 018 7902	TR 2SC380TM-O
CN750	614 035 2702	SOCKET, 2P(RCA TYPE), PHONO	Q2202	405 012 2002	TR 2SC1815-GR
CN751	614 035 2702	SOCKET, 2P(RCA TYPE), VIDEO	or	405 020 7204	TR 2SC945A-K
CN752	614 035 1712	SOCKET, PHONES(HEADPHONE)	Q2203	405 001 7001	TR 2SA1015-GR
CN753	614 218 0058	TERMINAL, 4P, SPEAKER	Q2301	405 012 2002	TR 2SC1815-GR
CT201	614 007 6356	TRIMMER, 11PF(WH), FM	or	405 020 7204	TR 2SC945A-K
D2101	407 105 0100	VARIABLE DI SVC211-B-AL	Q2302	405 067 0800	TR RN2207
D2102	407 105 0100	VARIABLE DI SVC211-B-AL	or	405 078 2404	TR BN1A4P
D2103	407 105 0100	VARIABLE DI SVC211-B-AL	or	405 000 0904	TR DTA114YS
D2104	407 007 9904	DIODE GMA01	Q2352	405 067 0800	TR RN2207
or	407 012 4406	DIODE 1SS133	or	405 078 2404	TR BN1A4P
or	407 012 5809	DIODE 1SS176	or	405 000 0904	TR DTA114YS
D2105	407 007 9904	DIODE GMA01	Q2355	405 067 0800	TR RN2207
or	407 012 4406	DIODE 1SS133	or	405 078 2404	TR BN1A4P
or	407 012 5809	DIODE 1SS176	or	405 000 0904	TR DTA114YS
D2201	407 007 9904	DIODE GMA01	Q2451	405 078 4903	TR 2SC2634-R
or	407 012 4406	DIODE 1SS133	or	405 078 5009	TR 2SC2634-S
or	407 012 5809	DIODE 1SS176	Q2452	405 078 4903	TR 2SC2634-R
D2301	407 007 9904	DIODE GMA01	or	405 078 5009	TR 2SC2634-S
or	407 012 4406	DIODE 1SS133	Q2701	405 012 2002	TR 2SC1815-GR
or	407 012 5809	DIODE 1SS176	or	405 020 7204	TR 2SC945A-K
D2302	407 007 9904	DIODE GMA01	Q2702	405 016 2206	TR 2SC2878-A
or	407 012 4406	DIODE 1SS133	or	405 016 2305	TR 2SC2878-B
or	407 012 5809	DIODE 1SS176	Q2801	405 012 2002	TR 2SC1815-GR
D2451	407 005 4505	DIODE DS442X	or	405 020 7204	TR 2SC945A-K
or	407 013 1701	DIODE 1S1588	Q2802	405 016 2206	TR 2SC2878-A
or	407 013 7109	DIODE 1S2473	or	405 016 2305	TR 2SC2878-B
D4061	407 012 4406	DIODE 1SS133	Q2901	405 012 2002	TR 2SC1815-GR
or	407 007 9904	DIODE GMA01	or	405 020 7204	TR 2SC945A-K
or	407 012 5809	DIODE 1SS176	Q4072	405 012 2002	TR 2SC1815-GR
D4062	407 012 4406	DIODE 1SS133	or	405 020 7204	TR 2SC945A-K
or	407 007 9904	DIODE GMA01	Q4083	405 000 6104	TR DTC144ES
or	407 012 5809	DIODE 1SS176	or	405 078 3005	TR BA1L4M
D4083	407 005 4505	DIODE DS442X	or	405 001 0408	TR RN1204
or	407 013 7109	DIODE 1S2473	or	405 018 2501	TR 2SC3399
or	407 013 1701	DIODE 1S1588	Q4084	405 012 2002	TR 2SC1815-GR
D4084	407 007 9904	DIODE GMA01	or	405 020 7204	TR 2SC945A-K
or	407 012 4406	DIODE 1SS133	Q4581	405 012 2002	TR 2SC1815-GR
or	407 012 5809	DIODE 1SS176	or	405 020 7204	TR 2SC945A-K
D4851	407 053 3208	ZENER DIODE MTZ12B	Q4582	405 012 2002	TR 2SC1815-GR
D4852	407 012 4406	DIODE 1SS133	or	405 020 7204	TR 2SC945A-K
or	407 007 9904	DIODE GMA01	Q4583	405 012 2002	TR 2SC1815-GR
or	407 012 5809	DIODE 1SS176	or	405 020 7204	TR 2SC945A-K
D4920	407 053 6704	ZENER DIODE MTZ5.6B	Q4681	405 012 2002	TR 2SC1815-GR
D4921	407 053 6704	ZENER DIODE MTZ5.6B	or	405 020 7204	TR 2SC945A-K

PARTS LIST

Ref. No.	Part No.	Description
Q4682	405 012 2002	TR 2SC1815-GR
or	405 020 7204	TR 2SC945A-K
Q4683	405 012 2002	TR 2SC1815-GR
or	405 020 7204	TR 2SC945A-K
Q4851	405 015 1606	TR 2SC2655-Y
Q4920	405 001 9302	TR 2SA1020-Y
Q4921	405 000 6104	TR DTC144ES
or	405 078 3005	TR BA1L4M
or	405 001 0408	TR RN1204
R2465	△ 401 018 1209	CARBON 33 JB 1/4W
R4709	401 009 5506	CARBON 330 JB 1/2W
R4809	401 009 5506	CARBON 330 JB 1/2W
R4851	△ 402 023 1703	FUSIBLE RES 100 J- 1/4W
RY701	614 224 4531	RELAY, SPEAKER RELAY
S3181	614 012 4316	SWITCH, BEAT CANCEL
or	614 023 8297	SWITCH, BEAT CANCEL
S4701	614 230 2521	SWITCH, PUSH, BASS XPANDER
SVR23	614 204 1901	SEMI-FIXED V.R., 10K (B)
T2201	614 030 3476	I. F. T., 107MHZ, FM
T2202	614 030 4114	I. F. T., 107MHZ, FM
X2451	614 229 2457	CRYSTAL, 7.2MHZ, FOR IC203

P.T PRIMARY P.C.BOARD ASSY

Ref. No.	Part No.	Description
72	614 245 0758	ASSY, PCB, P.T PRI
	614 017 8203	TERMINAL BOARD, AC-IN
F9999	△ 614 229 0422	INDUCTOR, FERITE, W/COVER, AC LINE FILTER
FCLP5	614 208 4540	FUSE HOLDER, FOR FU999
FCLP6	614 208 4540	FUSE HOLDER, FOR FU999

P.T SECONDARY P.C.BOARD ASSY

Ref. No.	Part No.	Description
73	614 245 0772	ASSY, PCB, P.T SEC
CN770	614 020 6579	SOCKET, 5P, TO POWER-AMP (AMP1)
or	614 223 9230	SOCKET, 5P, TO POWER-AMP (AMP1)
CN771	614 020 1246	SOCKET, 5P, TO POWER-AMP (AMP2)
ICP51	△ 614 205 2914	IC PROTECTOR ICP-N25
ICP52	△ 614 205 2914	IC PROTECTOR ICP-N25
R4931	△ 402 044 6701	RESISTOR 0.47 J- 1/2W
R4932	△ 402 044 0907	FUSIBLE RES 1 J- 1/4W
R4935	△ 402 044 1607	RESISTOR 0.33 J- 1/2W
R4936	△ 402 044 1607	RESISTOR 0.33 J- 1/2W

REGULATOR IC P.C.BOARD ASSY

Ref. No.	Part No.	Description
74	614 245 0796	ASSY, PCB, REG IC
CN750	614 020 6555	SOCKET, 3P, TO POWER-AMP
or	614 223 9216	SOCKET, 3P, TO POWER-AMP
IC952	△ 409 122 6202	IC NJM7812FA
or	△ 409 078 2402	IC L7812ML
or	△ 409 168 2107	IC UPC7812HF
or	△ 409 001 7603	IC AN7812F

POWER AMPLIFIER P.C.BOARD ASSY

Ref. No.	Part No.	Description
75	614 245 0819	ASSY, PCB, POWER AMP
	614 203 7362	HEAT SINK, FOR IC951

Ref. No.	Part No.	Description
C4907	403 053 4405	ELECT 2200U M 35V
C4908	403 053 4405	ELECT 2200U M 35V
C4938	403 053 4405	ELECT 2200U M 35V
CN800	614 020 6623	SOCKET, 10P, TO TUNER/PRE-AMP
or	614 223 9285	SOCKET, 10P, TO TUNER/PRE-AMP
CN801	614 020 6593	SOCKET, 7P, TO TUNER/PRE-AMP
or	614 223 9254	SOCKET, 7P, TO TUNER/PRE-AMP
CN802	614 020 1222	SOCKET, 3P, TO PRE3
CN812	614 017 2546	PLUG, 3P, TO CD3
CN850	614 020 6555	SOCKET, 3P, TO REG IC
or	614 223 9216	SOCKET, 3P, TO REG IC
CN870	614 020 6579	SOCKET, 5P, TO PT1
or	614 223 9230	SOCKET, 5P, TO PT1
CN871	614 020 1246	SOCKET, 5P, TO PT2
CN900	614 231 4302	SOCKET, 10P, TO TUNER/PRE-AMP
CN901	614 211 3349	SOCKET, 7P, TO TUNER/PRE-AMP
CN902	614 233 3082	ASSY, CONNECTOR-S, 3P, SP OUT
D4081	407 012 4406	DIODE 1SS133
or	407 007 9904	DIODE GMA01
or	407 012 5809	DIODE 1SS176
D4831	407 012 4406	DIODE 1SS133
or	407 007 9904	DIODE GMA01
or	407 012 5809	DIODE 1SS176
D4832	407 012 4406	DIODE 1SS133
or	407 007 9904	DIODE GMA01
or	407 012 5809	DIODE 1SS176
D4901	407 077 7800	DIODE RBV-402LF-A
D4906	407 053 3802	ZENER DIODE MTZ15C
D4910	407 012 4406	DIODE 1SS133
or	407 007 9904	DIODE GMA01
or	407 012 5809	DIODE 1SS176
D4911	407 012 4406	DIODE 1SS133
or	407 007 9904	DIODE GMA01
or	407 012 5809	DIODE 1SS176
D4912	407 012 4406	DIODE 1SS133
or	407 007 9904	DIODE GMA01
or	407 012 5809	DIODE 1SS176
D4913	407 012 4406	DIODE 1SS133
or	407 007 9904	DIODE GMA01
or	407 012 5809	DIODE 1SS176
D4914	407 050 2204	ZENER DIODE GZA30Y
D4931	407 012 3300	DIODE 1SR35-200A
D4932	407 012 3300	DIODE 1SR35-200A
D4933	407 012 3300	DIODE 1SR35-200A
D4934	407 012 3300	DIODE 1SR35-200A
FCLP1	614 208 4540	FUSE HOLDER, FOR FU701
FCLP2	614 208 4540	FUSE HOLDER, FOR FU701
FCLP3	614 208 4540	FUSE HOLDER, FOR FU801
FCLP4	614 208 4540	FUSE HOLDER, FOR FU801
IC752	409 047 0200	IC STK4132MK2
IC951	409 027 1005	IC L780512
Q4070	405 012 2002	TR 2SC1815-GR
or	405 020 7204	TR 2SC945A-K
Q4071	405 012 2002	TR 2SC1815-GR
or	405 020 7204	TR 2SC945A-K
Q4831	405 012 2002	TR 2SC1815-GR
or	405 020 7204	TR 2SC945A-K
Q4903	405 015 1606	TR 2SC2655-Y
Q4904	405 001 9302	TR 2SA1020-Y
Q4905	405 001 7209	TR 2SA1015-Y
Q4910	405 001 9302	TR 2SA1020-Y
R4706	401 008 7204	CARBON 2.2K JB 1/2W
R4708	401 010 5908	CARBON 5.6 JB 1/2W
R4806	401 008 7204	CARBON 2.2K JB 1/2W
R4808	401 010 5908	CARBON 5.6 JB 1/2W
R4841	△ 402 023 1703	FUSIBLE RES 100 J- 1/4W
R4844	△ 402 023 1703	FUSIBLE RES 100 J- 1/4W

PARTS LIST

Ref. No.	Part No.	Description
R4909	△ 402 004 4303	FUSIBLE RES 10 J- 1/4W
R4910	△ 402 004 4303	FUSIBLE RES 10 J- 1/4W
R4920	△ 402 004 6406	FUSIBLE RES 3.9 J- 1/4W
R4921	△ 402 023 1703	FUSIBLE RES 100 J- 1/4W

FRONT P.C.BOARD ASSY

Ref. No.	Part No.	Description
76	614 245 0710	ASSY,PCB,FRONT
	614 228 0232	MOUNT-E,TUN FL
	614 228 0249	MOUNT-E,TUN FL
C4573	403 135 3302	ELECT 1000U M 6.3V
or	403 196 4102	ELECT 1000U M 6.3V
C5021	403 196 9602	DL-ELECT 0.047F Z 5.5V
CN001	614 017 2591	PLUG,8P,TO DECK 1 MECHANISM
CN002	614 231 5330	ASSY,CONNECTOR-S,8P, TO DECK 2 MECHANISM
CN003	614 017 3871	PLUG,8P,TO DECK-AMP
CN004	614 226 9978	PLUG,10P(B-B),TO TUN/PRE
CN005	614 226 9930	PLUG,6P(B-B),TO TUN/PRE
CN006	614 226 9930	PLUG,6P(B-B),TO TUN/PRE
CN007	614 226 9930	PLUG,6P(B-B),TO TUN/PRE
CN008	614 226 9930	PLUG,6P(B-B),TO TUN/PRE
D4100	408 013 3207	LED SLZ-381C-09-A-T1,L.M
or	408 013 3306	LED SLZ-381C-09-B-T1,L.M
D4101	408 013 3207	LED SLZ-381C-09-A-T1,L.M
or	408 013 3306	LED SLZ-381C-09-B-T1,L.M
D4102	408 013 3207	LED SLZ-381C-09-A-T1,L.M
or	408 013 3306	LED SLZ-381C-09-B-T1,L.M
D4103	408 013 3207	LED SLZ-381C-09-A-T1,L.M
or	408 013 3306	LED SLZ-381C-09-B-T1,L.M
D4104	408 013 3207	LED SLZ-381C-09-A-T1,L.M
or	408 013 3306	LED SLZ-381C-09-B-T1,L.M
D4200	408 013 3207	LED SLZ-381C-09-A-T1,L.M
or	408 013 3306	LED SLZ-381C-09-B-T1,L.M
D4201	408 013 3207	LED SLZ-381C-09-A-T1,L.M
or	408 013 3306	LED SLZ-381C-09-B-T1,L.M
D4202	408 013 3207	LED SLZ-381C-09-A-T1,L.M
or	408 013 3306	LED SLZ-381C-09-B-T1,L.M
D4203	408 013 3207	LED SLZ-381C-09-A-T1,L.M
or	408 013 3306	LED SLZ-381C-09-B-T1,L.M
D4204	408 013 3207	LED SLZ-381C-09-A-T1,L.M
or	408 013 3306	LED SLZ-381C-09-B-T1,L.M
D4570	407 013 1701	DIODE 1S1588
or	407 013 7109	DIODE 1S2473
or	407 005 4505	DIODE DS442X
D4571	407 012 5809	DIODE 1SS176
or	407 012 4406	DIODE 1SS133
or	407 007 9904	DIODE GMA01
D4572	407 012 5809	DIODE 1SS176
or	407 012 4406	DIODE 1SS133
or	407 007 9904	DIODE GMA01
D4573	407 144 4206	ZENER DIODE MTZ3.0A
or	407 070 4004	ZENER DIODE GZS3.0X
D4590	408 013 2903	LED SLZ-181C-09-A-T1,V.M10
or	408 013 3009	LED SLZ-181C-09-B-T1,V.M10
D4591	408 013 2903	LED SLZ-181C-09-A-T1,V.M20
or	408 013 3009	LED SLZ-181C-09-B-T1,V.M20
D4592	408 013 2903	LED SLZ-181C-09-A-T1,V.M30
or	408 013 3009	LED SLZ-181C-09-B-T1,V.M30
D4593	408 013 2903	LED SLZ-181C-09-A-T1,V.M40
or	408 013 3009	LED SLZ-181C-09-B-T1,V.M40
D4594	408 013 2903	LED SLZ-181C-09-A-T1,VV.M50
or	408 013 3009	LED SLZ-181C-09-B-T1,VV.M50
D5010	407 012 5809	DIODE 1SS176
or	407 012 4406	DIODE 1SS133

Ref. No.	Part No.	Description
or	407 007 9904	DIODE GMA01
D5019	407 012 5809	DIODE 1SS176
or	407 012 4406	DIODE 1SS133
or	407 007 9904	DIODE GMA01
D5020	407 012 5809	DIODE 1SS176
or	407 012 4406	DIODE 1SS133
or	407 007 9904	DIODE GMA01
D5025	407 053 7503	ZENER DIODE MTZ6.8A
or	407 051 7406	ZENER DIODE GZS6.8X
D5030	407 053 5301	ZENER DIODE MTZ3.9C
or	407 051 5907	ZENER DIODE GZS3.9Z
or	407 053 5202	ZENER DIODE MTZ3.9B
D5050	407 013 1701	DIODE 1S1588
or	407 013 7109	DIODE 1S2473
or	407 005 4505	DIODE DS442X
D5051	407 013 1701	DIODE 1S1588
or	407 013 7109	DIODE 1S2473
or	407 005 4505	DIODE DS442X
D5052	407 013 1701	DIODE 1S1588
or	407 013 7109	DIODE 1S2473
or	407 005 4505	DIODE DS442X
D5053	407 013 1701	DIODE 1S1588
or	407 013 7109	DIODE 1S2473
or	407 005 4505	DIODE DS442X
D5054	407 012 5809	DIODE 1SS176
or	407 012 4406	DIODE 1SS133
or	407 007 9904	DIODE GMA01
D5055	407 012 5809	DIODE 1SS176
or	407 012 4406	DIODE 1SS133
or	407 007 9904	DIODE GMA01
D5056	407 012 5809	DIODE 1SS176
or	407 012 4406	DIODE 1SS133
or	407 007 9904	DIODE GMA01
D5057	407 012 5809	DIODE 1SS176
or	407 012 4406	DIODE 1SS133
or	407 007 9904	DIODE GMA01
D5058	407 012 5809	DIODE 1SS176
or	407 012 4406	DIODE 1SS133
or	407 007 9904	DIODE GMA01
D5059	407 012 5809	DIODE 1SS176
or	407 012 4406	DIODE 1SS133
or	407 007 9904	DIODE GMA01
D5060	407 012 5809	DIODE 1SS176
or	407 012 4406	DIODE 1SS133
or	407 007 9904	DIODE GMA01
D5061	407 012 5809	DIODE 1SS176
or	407 012 4406	DIODE 1SS133
or	407 007 9904	DIODE GMA01
D5062	407 012 5809	DIODE 1SS176
or	407 012 4406	DIODE 1SS133
or	407 007 9904	DIODE GMA01
D5063	407 013 1701	DIODE 1S1588
or	407 013 7109	DIODE 1S2473
or	407 005 4505	DIODE DS442X
D5070	407 012 5809	DIODE 1SS176
or	407 012 4406	DIODE 1SS133
or	407 007 9904	DIODE GMA01
D5071	407 012 5809	DIODE 1SS176
or	407 012 4406	DIODE 1SS133
or	407 007 9904	DIODE GMA01
D5099	407 053 6704	ZENER DIODE MTZ5.6B
or	407 051 6904	ZENER DIODE GZS5.6Y
D5212	407 013 1701	DIODE 1S1588
or	407 013 7109	DIODE 1S2473
or	407 005 4505	DIODE DS442X
D5220	407 013 1701	DIODE 1S1588
or	407 013 7109	DIODE 1S2473

PARTS LIST

Ref. No.	Part No.	Description	Ref. No.	Part No.	Description
or	407 005 4505	DIODE DS442X	IC410	409 020 0906	IC LB1403N
D5221	407 013 1701	DIODE 1S1588	or	409 003 0008	IC BA6124
or	407 013 7109	DIODE 1S2473	IC420	409 020 0906	IC LB1403N
or	407 005 4505	DIODE DS442X	or	409 003 0008	IC BA6124
D5310	407 012 5809	DIODE 1SS176	IC450	409 218 4303	IC RC4558S
or	407 012 4406	DIODE 1SS133	or	409 018 4909	IC LA6458S
or	407 007 9904	DIODE GMA01	IC457	409 218 4303	IC RC4558S
D5311	407 012 5809	DIODE 1SS176	or	409 018 4909	IC LA6458S
or	407 012 4406	DIODE 1SS133	IC458	409 053 0409	IC TC9153AP
or	407 007 9904	DIODE GMA01	IC459	409 020 2900	IC LB1433N
D5320	407 013 1701	DIODE 1S1588	IC500	410 135 0606	IC HD404729B40S
or	407 013 7109	DIODE 1S2473	L5020	614 028 4256	FILTER, 100UH, CHOKE
or	407 005 4505	DIODE DS442X	Q4670	405 078 3005	TR BA1L4M
D5321	407 013 1701	DIODE 1S1588	or	405 018 2501	TR 2SC3399
or	407 013 7109	DIODE 1S2473	or	405 000 6104	TR DTC144ES
or	407 005 4505	DIODE DS442X	or	405 001 0408	TR RN1204
D5322	407 013 1701	DIODE 1S1588	Q4671	405 078 3005	TR BA1L4M
or	407 013 7109	DIODE 1S2473	or	405 018 2501	TR 2SC3399
or	407 005 4505	DIODE DS442X	or	405 000 6104	TR DTC144ES
D5323	407 013 1701	DIODE 1S1588	or	405 001 0408	TR RN1204
or	407 013 7109	DIODE 1S2473	Q4672	405 078 3005	TR BA1L4M
or	407 005 4505	DIODE DS442X	or	405 018 2501	TR 2SC3399
D5324	407 012 5809	DIODE 1SS176	or	405 000 6104	TR DTC144ES
or	407 012 4406	DIODE 1SS133	or	405 001 0408	TR RN1204
or	407 007 9904	DIODE GMA01	Q4673	405 078 3005	TR BA1L4M
D5325	407 012 5809	DIODE 1SS176	or	405 018 2501	TR 2SC3399
or	407 012 4406	DIODE 1SS133	or	405 000 6104	TR DTC144ES
or	407 007 9904	DIODE GMA01	or	405 001 0408	TR RN1204
D5330	407 012 5809	DIODE 1SS176	Q5010	405 091 4201	TR BN1L4Z
or	407 012 4406	DIODE 1SS133	or	405 004 0504	TR 2SA1509
or	407 007 9904	DIODE GMA01	or	405 075 7907	TR DTA144TS
D5331	407 012 5809	DIODE 1SS176	Q5011	405 057 7604	TR 2SA1175-FF
or	407 012 4406	DIODE 1SS133	or	405 002 1107	TR 2SA1048-GR
or	407 007 9904	DIODE GMA01	or	405 002 5402	TR 2SA1175-EF
D5332	407 012 5809	DIODE 1SS176	or	405 003 5302	TR 2SA1317-T
or	407 012 4406	DIODE 1SS133	or	405 003 5401	TR 2SA1317-U
or	407 007 9904	DIODE GMA01	or	405 006 1806	TR 2SA933S-R
D5350	408 013 3207	LED SLZ-381C-09-A-T1, FOW	or	405 006 1905	TR 2SA933S-S
or	408 013 3306	LED SLZ-381C-09-B-T1, FOW	Q5025	405 020 7402	TR 2SC945A-P
D5351	408 013 3207	LED SLZ-381C-09-A-T1, REV	or	405 011 7404	TR 2SC1740-R
or	408 013 3306	LED SLZ-381C-09-B-T1, REV	or	405 011 7503	TR 2SC1740-S
D5352	408 013 2903	LED SLZ-181C-09-A-T1, REC	or	405 012 2002	TR 2SC1815-GR
or	408 013 3009	LED SLZ-181C-09-B-T1, REC	or	405 018 0101	TR 2SC3331-T
D5353	408 013 2903	LED SLZ-181C-09-A-T1, DECK 1	or	405 018 0200	TR 2SC3331-U
or	408 013 3009	LED SLZ-181C-09-B-T1, DECK 1	or	405 020 7204	TR 2SC945A-K
D5354	408 013 2903	LED SLZ-181C-09-A-T1, DECK 2	Q5030	405 091 4201	TR BN1L4Z
or	408 013 3009	LED SLZ-181C-09-B-T1, DECK 2	or	405 004 0504	TR 2SA1509
D5410	408 013 2903	LED SLZ-181C-09-A-T1, TAPE	or	405 075 7907	TR DTA144TS
or	408 013 3009	LED SLZ-181C-09-B-T1, TAPE	Q5220	405 091 4201	TR BN1L4Z
D5411	408 013 2903	LED SLZ-181C-09-A-T1, CD	or	405 004 0504	TR 2SA1509
or	408 013 3009	LED SLZ-181C-09-B-T1, CD	or	405 075 7907	TR DTA144TS
D5412	408 013 2903	LED SLZ-181C-09-A-T1, PHONO	Q5221	405 091 4201	TR BN1L4Z
or	408 013 3009	LED SLZ-181C-09-B-T1, PHONO	or	405 004 0504	TR 2SA1509
D5413	408 013 2903	LED SLZ-181C-09-A-T1, TUNER	or	405 075 7907	TR DTA144TS
or	408 013 3009	LED SLZ-181C-09-B-T1, TUNER	Q5310	405 091 4201	TR BN1L4Z
D5414	408 013 2903	LED SLZ-181C-09-A-T1, VIDEO	or	405 004 0504	TR 2SA1509
or	408 013 3009	LED SLZ-181C-09-B-T1, VIDEO	or	405 075 7907	TR DTA144TS
D5415	407 012 5809	DIODE 1SS176	Q5311	405 091 4201	TR BN1L4Z
or	407 012 4406	DIODE 1SS133	Q5311	405 004 0504	TR 2SA1509
or	407 007 9904	DIODE GMA01	or	405 075 7907	TR DTA144TS
D5416	407 012 5809	DIODE 1SS176	Q5320	405 091 4201	TR BN1L4Z
or	407 012 4406	DIODE 1SS133	or	405 004 0504	TR 2SA1509
or	407 007 9904	DIODE GMA01	or	405 075 7907	TR DTA144TS
D5420	407 053 6704	ZENER DIODE MTZ5.6B	Q5321	405 091 4201	TR BN1L4Z
or	407 051 6904	ZENER DIODE GZS5.6Y	or	405 004 0504	TR 2SA1509
FL500	614 226 7561	FLUORESCENT TUBE	or	405 075 7907	TR DTA144TS

PARTS LIST

Ref. No.	Part No.	Description	Ref. No.	Part No.	Description
Q5322	405 091 4201	TR BN1L4Z	or	405 001 0200	TR RN1202
or	405 004 0504	TR 2SA1509	Q5412	405 078 3005	TR BA1L4M
or	405 075 7907	TR DTA144TS	or	405 018 2501	TR 2SC3399
Q5323	405 091 4201	TR BN1L4Z	or	405 000 6104	TR DTC144ES
or	405 004 0504	TR 2SA1509	or	405 001 0408	TR RN1204
or	405 075 7907	TR DTA144TS	Q5413	405 057 7802	TR 2SC2785-FF
Q5324	405 091 4201	TR BN1L4Z	or	405 011 8500	TR 2SC1740S-R
or	405 004 0504	TR 2SA1509	or	405 011 8609	TR 2SC1740S-S
or	405 075 7907	TR DTA144TS	or	405 014 5209	TR 2SC2458-GR
Q5325	405 091 4201	TR BN1L4Z	or	405 015 6304	TR 2SC2785-EF
or	405 004 0504	TR 2SA1509	or	405 017 9600	TR 2SC3330-T
or	405 075 7907	TR DTA144TS	or	405 017 9709	TR 2SC3330-U
Q5330	405 105 7204	TR BA1L4Z	Q5414	405 057 7604	TR 2SA1175-FF
or	405 037 0601	TR 2SC3899	or	405 002 1107	TR 2SA1048-GR
or	405 075 8409	TR DTC144TS	or	405 002 5402	TR 2SA1175-EF
Q5331	405 105 7204	TR BA1L4Z	or	405 003 5302	TR 2SA1317-T
or	405 037 0601	TR 2SC3899	or	405 003 5401	TR 2SA1317-U
or	405 075 8409	TR DTC144TS	or	405 006 1806	TR 2SA933S-R
Q5340	405 078 2909	TR BA1A4M	or	405 006 1905	TR 2SA933S-S
or	405 018 2808	TR 2SC3402	or	405 057 7604	TR 2SA1175-FF
or	405 000 3103	TR DTC114ES	or	405 002 1107	TR 2SA1048-GR
or	405 001 0200	TR RN1202	or	405 002 5402	TR 2SA1175-EF
Q5341	405 078 2909	TR BA1A4M	or	405 003 5302	TR 2SA1317-T
or	405 018 2808	TR 2SC3402	or	405 003 5401	TR 2SA1317-U
or	405 000 3103	TR DTC114ES	or	405 006 1806	TR 2SA933S-R
or	405 001 0200	TR RN1202	or	405 006 1905	TR 2SA933S-S
Q5342	405 078 2909	TR BA1A4M	Q5441	405 057 7802	TR 2SC2785-FF
or	405 018 2808	TR 2SC3402	or	405 011 8500	TR 2SC1740S-R
or	405 000 3103	TR DTC114ES	or	405 011 8609	TR 2SC1740S-S
or	405 001 0200	TR RN1202	or	405 014 5209	TR 2SC2458-GR
Q5350	405 057 7604	TR 2SA1175-FF	or	405 015 6304	TR 2SC2785-EF
or	405 002 1107	TR 2SA1048-GR	or	405 017 9600	TR 2SC3330-T
or	405 002 5402	TR 2SA1175-EF	or	405 017 9709	TR 2SC3330-U
or	405 003 5302	TR 2SA1317-T	or	405 057 7802	TR 2SC2785-FF
or	405 003 5401	TR 2SA1317-U	or	405 011 8500	TR 2SC1740S-R
or	405 006 1806	TR 2SA933S-R	or	405 011 8609	TR 2SC1740S-S
or	405 006 1905	TR 2SA933S-S	or	405 014 5209	TR 2SC2458-GR
Q5351	405 057 7604	TR 2SA1175-FF	or	405 015 6304	TR 2SC2785-EF
or	405 002 1107	TR 2SA1048-GR	or	405 017 9600	TR 2SC3330-T
or	405 002 5402	TR 2SA1175-EF	or	405 017 9709	TR 2SC3330-U
or	405 003 5302	TR 2SA1317-T	R5025	401 168 9902	CARBON 100 JB 1/2W
or	405 003 5401	TR 2SA1317-U	R6421	401 168 9902	CARBON 100 JB 1/2W
or	405 006 1806	TR 2SA933S-R	RA500	614 209 3689	RESISTOR, 10K X8, SHRINK
or	405 006 1905	TR 2SA933S-S	or	614 217 1332	RESISTOR, 10K X8, SHRINK
Q5352	405 057 7604	TR 2SA1175-FF	S4670	614 220 5648	SWITCH, TACT, VOL UP
or	405 002 1107	TR 2SA1048-GR	S4671	614 220 5648	SWITCH, TACT, VOL DOWN
or	405 002 5402	TR 2SA1175-EF	S5000	614 217 8935	SWITCH, OPTO CONNECTOR, IR RECEIVE
or	405 003 5302	TR 2SA1317-T	S5050	614 220 5631	SWITCH, TACT, TIMER
or	405 003 5401	TR 2SA1317-U	S5051	614 220 5631	SWITCH, TACT, WACK UP
or	405 006 1806	TR 2SA933S-R	S5052	614 220 5631	SWITCH, TACT, SLEEP
or	405 006 1905	TR 2SA933S-S	S5053	614 220 5631	SWITCH, TACT, CLOCK
Q5353	405 107 8704	TR BA1A4Z	S5054	614 220 5631	SWITCH, TACT, POWER
or	405 037 0205	TR 2SC3860	S5200	614 220 5631	SWITCH, TACT, TUN UP
or	405 000 3400	TR DTC114TS	S5201	614 220 5631	SWITCH, TACT, TUN DOWN
or	405 035 1600	TR RN1211	S5202	614 220 5631	SWITCH, TACT, PST UP
Q5354	405 107 8803	TR BN1A4Z	S5203	614 220 5631	SWITCH, TACT, PST DOWN
or	405 038 2903	TR 2SA1497	S5204	614 220 5631	SWITCH, TACT, MEMORY
or	405 075 7600	TR DTA114TS	S5205	614 220 5631	SWITCH, TACT, CLEAR
or	405 107 8605	TR RN2211	S5206	614 220 5631	SWITCH, TACT, BAND
Q5410	405 078 3005	TR BA1L4M	S5207	614 220 5631	SWITCH, TACT, MODE
or	405 018 2501	TR 2SC3399	S5300	614 220 5631	SWITCH, TACT, STOP
or	405 000 6104	TR DTC144ES			
or	405 001 0408	TR RN1204			
Q5411	405 078 2909	TR BA1A4M			
or	405 018 2808	TR 2SC3402			
or	405 000 3103	TR DTC114ES			

PARTS LIST

Ref. No.	Part No.	Description
S5301	614 220 5631	SWITCH, TACT, FOW
S5302	614 220 5631	SWITCH, TACT, REV
S5303	614 220 5631	SWITCH, TACT, REC
S5304	614 220 5631	SWITCH, TACT, DECK 1/2
S6306	614 220 5631	SWITCH, TACT, SKIP FOW
S6308	614 220 5631	SWITCH, TACT, SKIP REV
S5307	614 220 5631	SWITCH, TACT, MUTE
S6308	614 220 5631	SWITCH, TACT, HI DUB
S5310	614 227 4323	SWITCH, SLIDE, REV MODE
S5315	614 227 4316	SWITCH, SLIDE, DOLBY
S5400	614 220 5631	SWITCH, TACT, TUNER
S5401	614 220 5631	SWITCH, TACT, CD
S5402	614 220 5631	SWITCH, TACT, TAPE
S5403	614 220 5631	SWITCH, TACT, PHONO
S5404	614 220 5631	SWITCH, TACT, VIDEO
VR450	614 229 4307	VR, SLIDE, 100K(W), BALANCE
VR451	614 229 4291	VR, SLIDE, 50K(B) X2, G.-EQ, 100HZ
VR452	614 229 4291	VR, SLIDE, 50K(B) X2, G.-EQ, 300HZ
VR453	614 229 4291	VR, SLIDE, 50K(B) X2, G.-EQ, 1KHZ
VR454	614 229 4291	VR, SLIDE, 50K(B) X2, G.-EQ, 3KHZ
VR455	614 229 4291	VR, SLIDE, 50K(B) X2, G.-EQ, 12KHZ
X5000	614 229 3300	RESONATOR, XTAL, 4.19MHZ, FOR IC500

TAPE DECK AMPLIFIER P.C.BOARD ASSY

Ref. No.	Part No.	Description
77	614 229 2624	ASSY, PCB, DECK AMP
C3303	403 058 2426	POLYESTER 0.015U J 50V
C3304	403 058 1112	POLYESTER 1500P K 50V
C3500	403 134 8110	ELECT 100U M 6.3V
CN301	614 017 2591	PLUG, 8P, TO TUNER/PRE-AMP
CN302	614 017 2591	PLUG, 8P, TO FRONT
CN303	614 016 4084	PLUG, 2P, TEST PIN, HIGH SPEED
CN331	614 017 2539	PLUG, 2P, E HEAD
CN371	614 017 2553	PLUG, 4P, P HEAD
CN372	614 017 2560	PLUG, 5P, R/P HEAD
CN373	614 035 5949	SOCKET, 3P, TEST PIN, TAPE OUT
D3101	407 007 9904	DIODE GMA01
or	407 012 4406	DIODE 1SS133
D3102	407 007 9904	DIODE GMA01
or	407 012 4406	DIODE 1SS133
D3103	407 007 9904	DIODE GMA01
or	407 012 4406	DIODE 1SS133
D3104	407 007 9904	DIODE GMA01
or	407 012 4406	DIODE 1SS133
D3105	407 005 4505	DIODE DS442X
or	407 013 7109	DIODE 1S2473
D3106	407 007 9904	DIODE GMA01
or	407 012 4406	DIODE 1SS133
HS301	614 211 3592	HEAT SINK, BIAS LEAK
IC351	409 119 8803	IC CXA1101P
IC370	409 121 8702	IC LA3246
IC371	409 207 1900	IC MLC4066B
or	409 003 9506	IC BU4066B
or	409 051 3501	IC TC4066BP
or	409 059 2605	IC UPD4066BC
IC374	409 214 1900	IC CXA1298AP
IC375	409 145 8405	IC UPC1330HA
L3300	614 221 8280	TRANS, OSC

Ref. No.	Part No.	Description
L3601	614 029 3807	MX COIL, 3.3K-5.6K 85KHZ
L3651	614 029 3807	MX COIL, 3.3K-5.6K 85KHZ
L3700	614 028 4379	FILTER, 1000UH
L3731	614 210 3685	INDUCTOR, FERITE, 3.3MH
L3750	614 029 3142	MX COIL, 85KHZ
L3800	614 028 4379	FILTER, 1000UH
L3831	614 210 3685	INDUCTOR, FERITE, 3.3MH
L3850	614 029 3142	MX COIL, 85KHZ
Q3101	405 000 6104	TR DTC144ES
or	405 078 3005	TR BA1L4M
or	405 103 9606	TR AA1L4M
or	405 001 0408	TR RN1204
Q3102	405 000 2205	TR DTA144ES
or	405 078 2107	TR BN1L4M
or	405 103 9705	TR AN1L4M
or	405 001 1306	TR RN2204
Q3103	405 000 6104	TR DTC144ES
or	405 078 3005	TR BA1L4M
or	405 103 9606	TR AA1L4M
or	405 001 0408	TR RN1204
Q3104	405 075 8409	TR DTC144TS
or	405 105 7204	TR BA1L4Z
Q3106	405 000 6104	TR DTC144ES
or	405 078 3005	TR BA1L4M
or	405 103 9606	TR AA1L4M
or	405 001 0408	TR RN1204
Q3108	405 000 6104	TR DTC144ES
or	405 078 3005	TR BA1L4M
or	405 103 9606	TR AA1L4M
or	405 001 0408	TR RN1204
Q3107	405 000 2205	TR DTA144ES
or	405 078 2107	TR BN1L4M
or	405 103 9705	TR AN1L4M
or	405 001 1306	TR RN2204
Q3108	405 000 6104	TR DTC144ES
or	405 078 3005	TR BA1L4M
or	405 103 9606	TR AA1L4M
or	405 001 0408	TR RN1204
Q3109	405 075 8409	TR DTC144TS
or	405 105 7204	TR BA1L4Z
Q3160	405 000 6104	TR DTC144ES
or	405 078 3005	TR BA1L4M
or	405 103 9606	TR AA1L4M
or	405 001 0408	TR RN1204
Q3181	405 000 2205	TR DTA144ES
or	405 078 2107	TR BN1L4M
or	405 103 9705	TR AN1L4M
or	405 001 1306	TR RN2204
Q3300	405 012 2002	TR 2SC1815-GR
or	405 020 7204	TR 2SC945A-K
or	405 011 7503	TR 2SC1740-S
Q3301	405 011 1907	TR 2SC1627-Y
Q3302	405 001 7001	TR 2SA1015-GR
or	405 005 2002	TR 2SA733-P
Q3303	405 012 2002	TR 2SC1815-GR
or	405 020 7204	TR 2SC945A-K
or	405 011 8609	TR 2SC1740S-S
Q3730	405 012 2002	TR 2SC1815-GR
or	405 020 7204	TR 2SC945A-K
or	405 011 8609	TR 2SC1740S-S
Q3830	405 012 2002	TR 2SC1815-GR
or	405 020 7204	TR 2SC945A-K
or	405 011 8609	TR 2SC1740S-S
SVR30	614 003 6190	SEMI-FIXED V.R, 20K(B)
SVR31	614 003 6190	SEMI-FIXED V.R, 20K(B)
SVR32	614 003 6190	SEMI-FIXED V.R, 20K(B)

PARTS LIST

Ref. No.	Part No.	Description
SVR33	614 003 6190	SEMI-FIXED V.R, 20K(B)
SVR34	614 003 6183	SEMI-FIXED V.R, 10K(B)
SVR35	614 003 6183	SEMI-FIXED V.R, 10K(B)
SVR36	614 003 6213	SEMI-FIXED V.R, 50K(B)
SVR37	614 003 6213	SEMI-FIXED V.R, 50K(B)

CD MAIN P.C.BOARD ASSY

Ref. No.	Part No.	Description
78	614 230 0442	ASSY, PCB, CD MAIN
C1603	403 043 3104	ELECT 2200U M 16V
C1604	403 042 6205	ELECT 1000U M 16V
CN101	614 017 2577	PLUG, 6P, PICK SENSOR
CN102	614 228 0911	PLUG, 8P, PICK ACT
CN103	614 017 2553	PLUG, 4P, SLED-SPINDLE MOTOR
CN104	614 017 2546	PLUG, 3P, MECHA SWITCH
CN105	614 017 2546	PLUG, 3P, AC GND AC
CN106	614 017 2546	PLUG, 3P, LINE OUT
CN107	614 208 2355	SOCKET, 8P(B-B), CD MAIN-CD FRONT
CN108	614 208 2352	SOCKET, 9P(B-B), CD MAIN-CD FRONT
CN109	614 017 2560	PLUG, 5P, TO TUN/PRE-AMP
CN110	614 016 3865	PLUG, 4P, TP1-4
D102	407 003 4507	DIODE DAP202K
D103	407 003 4507	DIODE DAP202K
D111	X407 004 9105	DIODE DSF10C
or	X407 012 3300	DIODE 1SR35-200A
D112	X407 004 9105	DIODE DSF10C
or	X407 012 3300	DIODE 1SR35-200A
D113	X407 004 9105	DIODE DSF10C
or	X407 012 3300	DIODE 1SR35-200A
D114	X407 004 9105	DIODE DSF10C
or	X407 012 3300	DIODE 1SR35-200A
D131	407 003 4507	DIODE DAP202K
IC101	409 245 4802	IC LA9210M
IC102	X409 018 5500	IC LA6510
IC103	X409 018 5500	IC LA6510
IC104	409 248 8708	IC LC7866E
IC105	409 206 9006	IC LC97000P-288
IC106	409 241 5506	IC XRA15218F
IC107	410 122 3504	IC CXP5046H-259S
IC108	X409 195 4105	IC M5294P
L1701	X614 028 4256	FILTER, 100UH, CHOKE
Q101	405 002 0308	TR 2SA1037K-R
Q102	405 014 4509	TR 2SC2412K-R
Q103	405 000 4100	TR DTC124EK
Q105	405 014 4509	TR 2SC2412K-R
Q111	405 000 0409	TR DTA114EK
Q112	405 029 3207	TR DTC114TK
Q118	405 014 4509	TR 2SC2412K-R
SVR11	614 223 1906	POTENTIOMETER, 10K(B), T BALANCE
X101	614 225 6633	RESONATOR, CERAM, 16.9344MHZ, FOR IC104
X102	614 215 5523	RESONATOR, CERAM, 4.19MHZ, FOR IC107
or	614 215 5561	RESONATOR, CERAM, 4.19MHZ, FOR IC107

CD FRONT P.C.BOARD ASSY

Ref. No.	Part No.	Description
79	614 230 0459	ASSY, PCB, CD SWITCH
CN117	614 208 2263	PLUG, 8P(B-B), CD FRONT-MAIN

Ref. No.	Part No.	Description
CN118	614 208 2270	PLUG, 9P(B-B), CD FRONT-MAIN
O121	407 018 9405	LED SL-1283, 2 DIGIT
D122	407 003 4507	DIODE DAP202K
D123	407 003 4507	DIODE DAP202K
D124	408 013 3207	LED SLZ-381C-09-A-T1, PLAY(GR)
or	408 013 3306	LED SLZ-381C-09-B-T1, PLAY(GR)
D125	408 013 2903	LED SLZ-181C-09-A-T1, REPEAT
or	408 013 3009	LED SLZ-181C-09-B-T1, REPEAT
D126	408 013 2903	LED SLZ-181C-09-A-T1, PROGRAM
or	408 013 3009	LED SLZ-181C-09-B-T1, PROGRAM
D127	408 013 3207	LED SLZ-381C-09-A-T1, RANDOM(GR)
or	408 013 3306	LED SLZ-381C-09-B-T1, RANDOM(GR)
D128	408 013 2903	LED SLZ-181C-09-A-T1, EDIT
or	408 013 3009	LED SLZ-181C-09-B-T1, EDIT
D129	408 013 2903	LED SLZ-181C-09-A-T1, SIDE-A
or	408 013 3009	LED SLZ-181C-09-B-T1, SIDE-A
D130	408 013 2903	LED SLZ-181C-09-A-T1, SIDE-B
or	408 013 3009	LED SLZ-181C-09-B-T1, SIDE-B
Q115	405 108 4507	TR DTA123YK
Q116	405 108 4507	TR DTA123YK
Q117	405 108 4507	TR DTA123YK
S1701	614 220 5631	SWITCH, TACT, MEMORY
S1702	614 220 5631	SWITCH, TACT, PLAY/PAUSE
S1703	614 220 5631	SWITCH, TACT, OPEN/CLOSE
S1704	614 220 5631	SWITCH, TACT, REPEAT
S1705	614 220 5631	SWITCH, TACT, BACK
S1706	614 220 5631	SWITCH, TACT, FWD
S1707	614 220 5631	SWITCH, TACT, STOP
S1708	614 220 5631	SWITCH, TACT, EDIT

PARTS LIST

TAPE DECK MECHANISM (TM-SF3J/SP)

Ref. No.	Part No.	Description	Ref. No.	Part No.	Description
TM01	614 219 9657	ASSY, CHASSIS, TAPE DECK	TM66	614 220 0032	LEVER, R/F B
TM02	614 195 9139	SPRING PLATE, CASSETTE PRES	TM67	614 219 9855	GEAR, R/F MOVE
TM03	614 219 9671	ASSY, FLYWHEEL, REV, D2.0	TM68	614 220 0281	PIPE, R/F MOVE GEAR FIX
TM04	614 219 9688	ASSY, FLYWHEEL, NOR, D2.2	TM69	614 219 9879	GEAR, D. CAM
TM05	412 034 4709	SPECIAL WASHER, REV FW FIX	TM70	614 220 0049	LEVER, MAIN TRIGGER
TM06	412 014 3006	SPECIAL WASHER, NOR FW FIX	TM71	614 220 0056	LEVER, SUB TRIGGER
TM07	412 029 8200	SPECIAL WASHER, REV OIL PRF	TM72	614 223 8745	SLIDE, DRIVE
TM08	412 012 7005	SPECIAL WASHER, NOR OIL PRF	TM73	614 220 1299	SPRING, WIRE, D. SLIDE RESET
TM09	614 219 9596	ASSY, COMMUTATE MOTOR	TM74	614 220 0186	SLIDE, A/B MECHA CHANGE
TM10	614 223 8677	BRACKET-E, MOTOR	TM75	614 229 7506	SPRING, TENS, CHANGE SLIDE
TM11	614 219 9954	BELT, SQUARE, A-MECHA DRIVE	TM76	614 229 7513	SPRING, TENS, TRIGGER INNER FORCE
TM12	614 219 9951	BELT, SQUARE, B-MECHA DRIVE			
TM13	614 195 8644	PULLEY, BELT DUMMY	TM77	614 219 9718	ASSY, SLIDE, HEAD CHANGE
TM14	412 022 0607	SPECIAL WASHER, D. PULLEY	TM78	614 220 1305	SPRING, WIRE, CHANGE SLIDE
TM15	614 220 0001	LEVER, PLAY GEAR	TM79	614 220 0209	SLIDE, REEL CHANGE NO.1
TM16	614 220 1657	ASSY, GEAR, PLAY CLUTCH	TM80	614 219 9725	ASSY, SLIDE, REEL CHANGE NO.2
TM17	614 220 0261	PIPE, PLAY SLIP FIX	TM81	614 220 0346	SWITCH, LEAF, PACK1, S003
TM18	614 224 5293	CUSHION, BELT TUTCH(B)	or	614 220 0346	SWITCH, LEAF, PACK2, S004
TM19	614 224 5309	CUSHION, BELT TUTCH(A)	or	614 220 0346	SWITCH, LEAF, CROM1, S005
TM20	614 236 5397	SPRING, TENS, PLAY LEVER RSET	or	614 220 0346	SWITCH, LEAF, CROM2, S006
TM21	614 219 9817	GEAR, RELAY FIXED	or	614 220 0346	SWITCH, LEAF, URFRWD, S007
TM22	614 220 0261	PIPE, GEAR FIX	or	614 220 0346	SWITCH, LEAF, URREV, S008
TM23	614 220 1664	ASSY, GEAR, TAKE UP MOVE	TM82	614 225 6916	CUSHION, RUBBER, SILEN
TM24	614 220 0025	LEVER, TAKE UP MOVE B	TM83	614 226 6854	CUSHION, RF LEVER TOUCH
TM25	614 220 1268	SPRING, WIRE, B MECHA REEL CHANGE CLIC	TM84	614 229 1313	CUSHION, RUBBER, DRIVE SLIDE WIRE STOPPER
TM26	614 219 9848	GEAR, REEL RELAY	TM85	614 228 5053	CUSHION, RUBBER, H.S. STOPPER
TM27	614 219 9831	GEAR, REEL	TM86	614 228 2311	CUSHION, RF LEVER, SILEN
TM28	614 219 9886	REEL, RIGHT			
TM29	614 219 9893	REEL, LEFT			
TM30	614 220 1251	SPRING, COMP, BACK TENSION L			
TM31	614 219 9695	ASSY, LEVER, PINCH, LEFT			
TM32	614 219 9701	ASSY, LEVER, PINCH, LIGHT			
TM33	614 229 7520	SPRING, WIRE, PINCH LEFT			
TM34	614 220 1275	SPRING, WIRE, PINCH RIGHT			
TM35	614 220 0070	LEVER, BRAKE R			
TM36	614 220 0087	LEVER, BRAKE L			
TM37	614 220 0162	SLIDE, DOOR LOCK A			
TM38	614 220 0179	SLIDE, DOOR LOCK B			
TM39	614 220 0247	SLIDE, EJECT RELAY A			
TM40	614 220 0254	SLIDE, EJECT RELAY B			
TM41	614 220 1190	SPRING, TENS, EJECT RELAY			
TM42	614 220 0339	MAGNETIC COIL, SOLENOID			
TM43	614 220 1626	ASSY, PCB, MECHA			
TM44	614 219 9770	SHIELD, HEAD PCB			
TM45	614 222 8968	PCB, P LEAD RELAY			
TM46	614 222 8975	PCB, R/P LEAD RELAY			
TM47	614 220 0148	LEVER, D. SLIDE LOCK			
TM48	614 220 1312	SPRING, WIRE, LOCK LEVER			
TM49	614 232 5414	LEVER, HEAD SLIDE UP A			
TM50	614 220 0131	LEVER, HEAD SLIDE UP B			
TM51	614 220 1688	ASSY, SLIDE, HEAD			
TM52	614 220 1329	SPRING, WIRE, HEAD SLIDE			
TM53	614 220 1183	SPRING, TENS, HEAD SILED CONT			
TM54	614 219 9763	GUIDE, TAPE			
TM55	614 220 1633	ASSY, BRACKET-E, HEAD LOCATE			
TM56	614 220 0292	HEAD, REC/PLAY			
TM57	614 220 0308	HEAD, PLAY			
TM58	614 220 4900	GEAR, HEAD ROTARY			
TM59	412 012 7609	SPECIAL WASHER, HEAD THRUST			
TM60	614 220 0063	LEVER, SECTOR			
TM61	614 220 1336	SPRING, WIRE, HEAD CLIC			
TM62	614 226 5543	SPRING, COMP, AZIMUTH COIL			
TM63	412 031 2005	SPECIAL SCREW, AZIMUTH BISS			
TM64	614 221 8235	SPRING, WIRE, HEAD SLIDE GND			
TM65	614 219 9992	LEVER, R/F A			

FIXING PARTS FOR TAPE DECK MECHANISM

Ref. No.	Part No.	Description
TY01	411 102 6300	SCR PAN-FLG 2.6X2.8, MOTOR
TY02	411 021 6405	SCR S-TPG BIN 3X8, B-MOTOR
TY03	411 044 7205	SCR PAN+SW 2X4, SOLENOID
TY04	411 021 0809	SCR S-TPG BIN 2X6
TY05	411 022 7807	SCR S-TPG PAN 2X6, TAPE GUID
TY06	411 124 9204	SCR PAN PCS 1.5X6, HEAD FIX
TY07	411 018 8401	SCR PAN PCS 2X2, REEL CH SLIDE NO.2

TAPE DECK MECHANISM P.C.BOARD ASSY

Ref. No.	Part No.	Description
TM43	614 220 1626	ASSY, PCB, MECHANISM
CN001	614 017 3871	PLUG, 8P, CN001, TAPE A
CN002	614 235 3646	PLUG, 8P, CN002, TAPE B
CN003	614 036 4935	SOCKET, 4P, CN003, TO MOTOR
D001	407 004 9105	DIODE DSF10C
or	407 012 3300	DIODE 1SR35-200A
D002	407 007 9904	DIODE GMA01
or	407 012 4408	DIODE 1SS133
D003	407 051 6706	ZENER DIODE GZS6.1Y
or	407 053 6308	ZENER DIODE MTZ6.1B
PH001	407 131 9900	PHOTO COUPLE SPI-335-34-C
PH002	407 131 9900	PHOTO COUPLE SPI-335-34-C
ICP01	614 205 2884	IC PROTECTOR ICP-N10
Q001	△ 405 099 0908	TR 2SB621-S
Q002	405 002 1107	TR 2SA1048-GR
or	405 006 1905	TR 2SA933S-S
Q003	△ 405 099 0908	TR 2SB621-S
S001	614 224 2575	SWITCH, LEVER, PLAY
S002	614 224 2575	SWITCH, LEVER, STOP
SV001	614 003 6190	SEMI-FIXED V.R., 20K(B)

EXPLODED VIEW (TAPE MECHANISM)

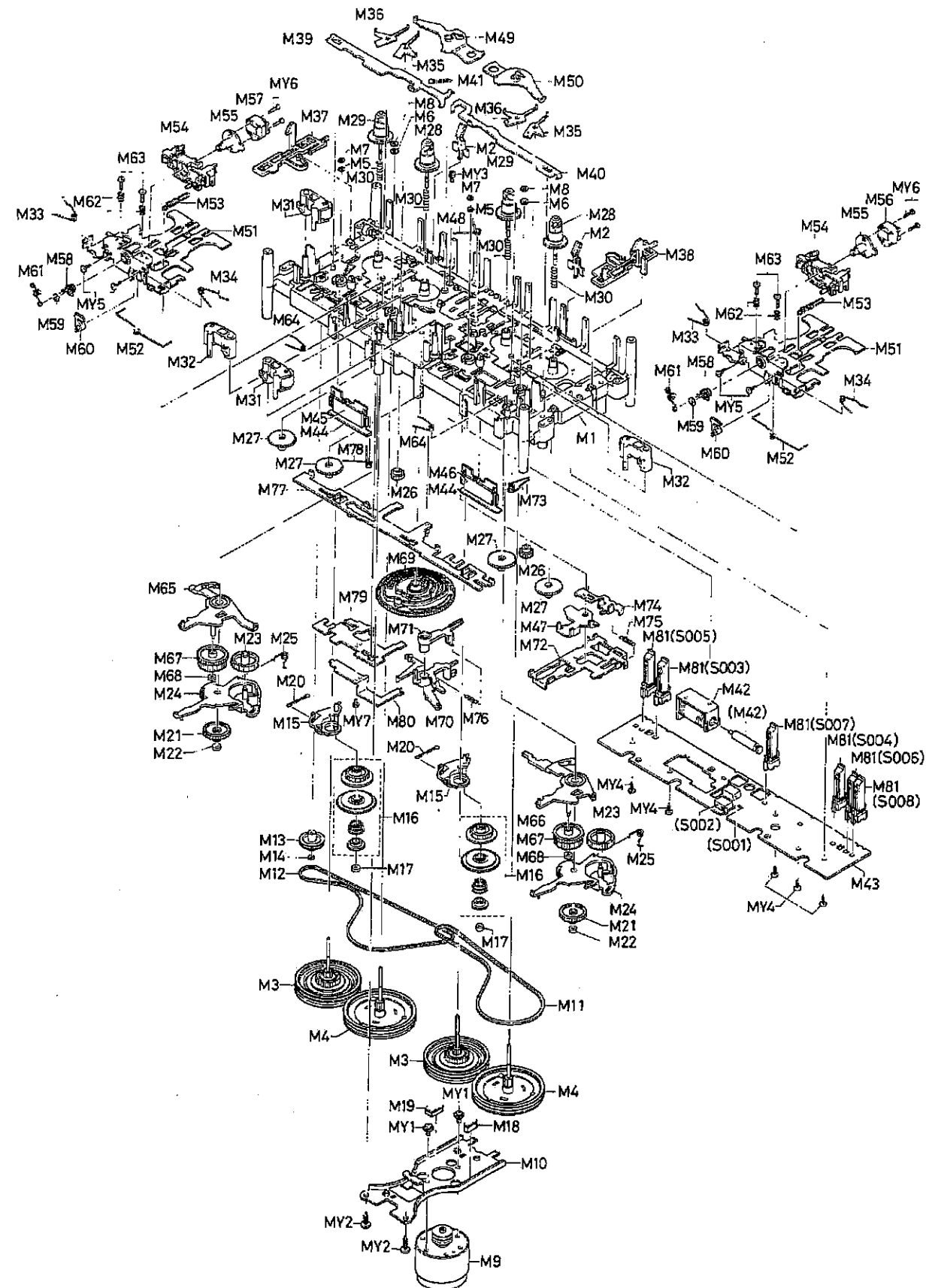

EXPLODED VIEW & PARTS LIST (CD MECHANISM)

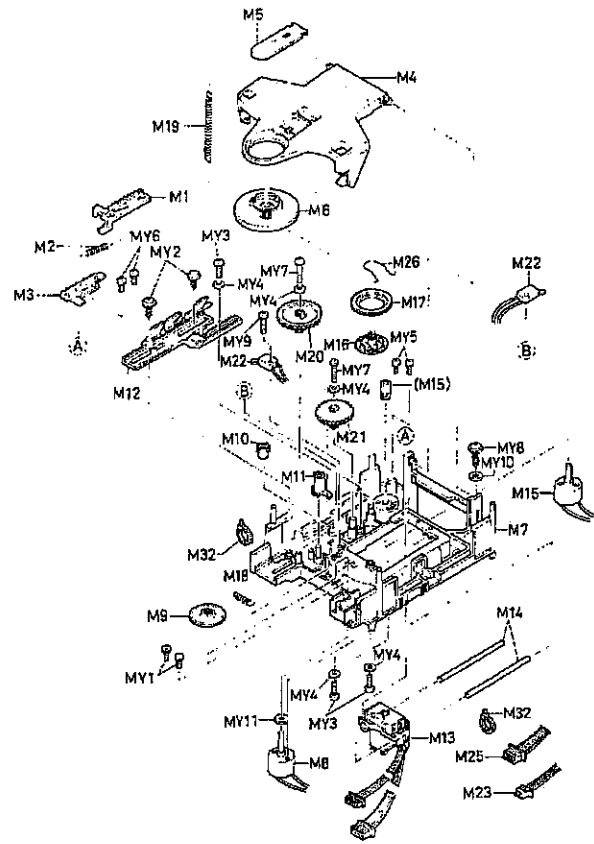

Ref. No.	Part No.	Description
M03	614 216 9759	GEAR,PICKUP,RACK LOWER
M04	614 216 9858	LEVER,CHUCK
M05	614 211 6654	SPRING PLATE,CHUCK
M06	614 219 0104	ASSY,PULLEY,CHUCK
M07	614 216 9728	CHASSIS,CD MECHANISM
M08	614 045 2105	COMMUTATE MOTOR,SPINDLE
M09	614 216 9841	TURNTABLE,CHUCK
or	614 238 0413	TURNTABLE,CHUCK
M10	614 216 9742	GEAR,CHANGE SLIDE
M11	614 216 9810	GEAR,CHANGE RACK
M12	614 216 9865	SLIDE,DRIVING
M13	614 227 9069	PICKUP,LASER
M14	614 145 9622	SHAFT,PICKUP GUIDE
or	614 230 0411	SHAFT,PICKUP GUIDE
M15	614 217 7068	COMMUTATE MOTOR ASSY,SLED
M16	614 216 9797	GEAR,CLUTCH INNER
M17	614 216 9780	GEAR,CLUTCH OUTER
M18	614 216 9889	SPRING,TENS,SLIDE BACK
M19	614 223 2217	SPRING,TENS,CHUCK LEVER BACK
M20	614 216 9773	GEAR,TRAY SLED
M21	614 216 9803	GEAR,PICKUP SLED
M22	614 018 9223	SWITCH,LIMIT & LOAD OUT
M23	614 224 3138	ASSY,CONNECTOR-S,3P,SWITCH
M25	614 224 3145	ASSY,CONNECTOR-S,4P,SWITCH
M26	614 216 9902	SPRING,WIRE,CLUTCH
M32	614 129 4971	FIXER,LEAD FIX
M33	614 217 8713	SHEET,CHASSIS

FIXING PARTS (CD MECHANISM)

Ref. No.	Part No.	Description
MY01	411 044 7205	SCR PAN+SW 2X4
MY02	411 020 9902	SCR S-TPG BRZ+FLG 3X8
MY03	411 022 8408	SCR S-TPG PAN 2X8
MY04	411 087 4704	WASHER V 2XB0.4
MY05	411 044 7205	SCR PAN+SW 2X4
MY06	411 044 7502	SCR PAN+SW 2X5
MY07	411 119 8908	SCR S-TPG PAN 2X14
MY08	411 020 9100	SCR S-TPG BRZ+FLG 3X12
MY09	411 104 4205	SCR TPG PAN PCS 1.7X8
MY10	411 092 2900	WASHER Z 3X10X1
MY11	412 032 0208	SPECIAL WASHER,ADHESIVE ESCAPE STOP

CD MECHANISM (PM-DAD S6N/SP)

Ref. No.	Part No.	Description
M01	614 216 9766	GEAR,PICKUP,RACK UPPER
M02	614 216 9896	SPRING,COMP,RACK BACK

IC BLOCK DIAGRAM

IC108 M5294P (5-Terminal Voltage Regulator with System-Reset & Muting)

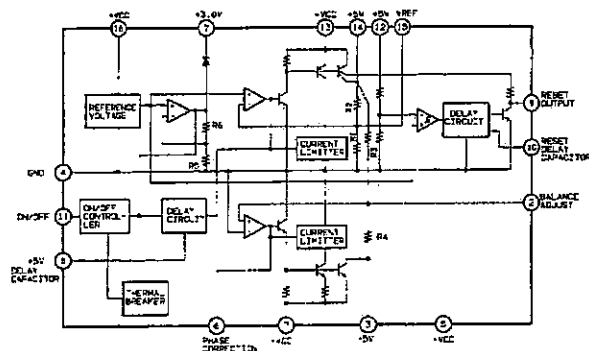

IC201 LA1265S-AUD (AM-RF & FM - AM-IF System)

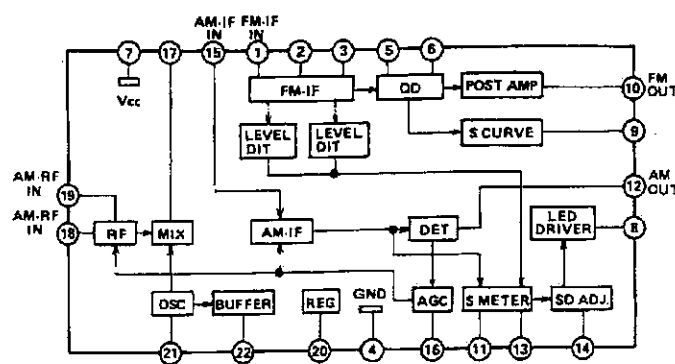

IC BLOCK DIAGRAM

IC104 Pin Function of LC7866E (Digital Signal Processor & Servo Control)

No	Pin Name	I/O	Description	No	Pin Name	I/O	Description
1	TEST1	I	For TEST. Normal time is non connection.	31	SMP2	O	Output of signal to DAC, Signal of Latch & L/R select, Signal for Sampling Hold
2	AO	O	Input from VCO output in LA921D (.8.6436MHz)	32	SMP1	O	Output of signal to DAC, Signal of Latch & L/R select, Signal for Sampling Hold
3	AI	I	Phase comparison output of VCO and EFM signal.	33	LRCLK	O	Output of signal to DAC, Signal of Latch & L/R select, Signal for Sampling Hold
4	PDO	O		34	SMP	O	Output of signal to DAC, Signal of Latch & L/R select, Signal for Sampling Hold
5	VSS		GND	35	DFOUT	O	Output of signal to DAC, Signal of Latch & L/R select, Signal for Sampling Hold
6	EFMO	O	Negative output through amplitude limiter. Antiphase of EFMO. This signal use SLICE LEVEL CONTROL.	36	DACLK	O	Output of signal to DAC, Signal of Latch & L/R select, Signal for Sampling Hold
7	EFMO	O	Positive output through amplitude limiter. Antiphase of EFMO. This signal use SLICE LEVEL CONTROL.	37	TESTB	O	For TEST. Normal time is non connection.
8	EFMIN	I	Inputting HF signal of 1~2Vp.p. This signal use SLICE LEVEL CONTROL.	38	TESTC	O	For TEST. Normal time is non connection.
9	TEST2	I	For TEST. Normal time is non connection.	39	CK2	O	For output of signal that Comply with CD-ROM
10	CLV+	O	Output for DISC MOTOR CONTROL.	40	ROMDOUT	O	For output of signal that Comply with CD-ROM
11	CLV-	O	Output for DISC MOTOR CONTROL.	41	C2FLCK	D	For output of signal that Comply with CD-ROM
12	V/P	O	CLV rough Servo time : Output "H" Phase control time : Output "L"	42	C2F	O	For output of signal that Comply with CD-ROM
13	FOCS	O	Output "H" : Lens pull up with slowly than stop the Focus Servo. If FZD generate, it reset output of FOCS. For lead-in of Focus	43	DOUT	O	Output of DIGITAL OUT
14	EST	O		44	SBSY	O	Synchronizing signal of sub-code block.
15	FZD	I		45	EFLG	O	For correction monitor of C1, C2, single, double.
16	HFL	I	Comply with command of track jump, it oscillate kick Pulse, JP+ & JP-. It jump the prescribed number of track (1,4,16,64).	46	PW	O	SFSY is Synchronizing signal of sub-code & frame. Clock of eighth send to SBCK then read out the sub-code of P, Q, R, S, T, U, V, & W.
17	TES	I	Comply with command of track Jump, it oscillate kick Pulse, JP+ & JP-. It jump the prescribed number of track (1,4,16,64).	47	SFSY	O	
18	PCK	O	PCK Monitor (4.3218MHz)	48	SBCK	I	
19	FSEQ	O	SYNC (FS of truth) detected from EFM signal = SYNC of counter : "H" (Latch Output during in 1 frame)	49	FSX	O	Output of Synchronizing signal (7.35KHz)
20	TOFF	O	Comply with command of track jump, it oscillate kick Pulse, JP+ & JP-. It jump the prescribed number of track (1,4,16,64).	50	WRQ	O	Data sub-code Q pass the CRC check then WRQ do "H". It detect at external. Data read out from SQOUT by send the COCK. RWC set the "H" by Micro Processor then it let command by send with Synchronizing COCK command data.
21	TGL	O		51	RWC	O	
22	THLD	O		52	SQOUT	O	
23	TEST3	I	For TEST. Normal time is non connection.	53	CDIN	I	
24	VDD		+5V	54	COCK	I	
25	JP+	O	Comply with command of track Jump, it oscillate kick Pulse, JP+ & JP-. It jump the prescribed number of track (1,4,16,64).	55	RES	I	Turn on the Power Supply time : Once "L"
26	JP-	O	Comply with command of track Jump, it oscillate kick Pulse, JP+ & JP-. It jump the prescribed number of track (1,4,16,64).	56	M/L	I	Data of SQOUT want at the LBS first time : M/L set the "L".
27	DEMO	I	For adjustment of production process. Sound on function.	57	LASER	O	This output can control at Serial Control from Micro Processor
28	TEST4	I	For TEST. Normal time is non connection.	58	16M	O	16M Output (16.9344MHz)
29	EMPH	O	Output is "H" time, it need de-emphasis	59	4M	O	4M Output (4.2336MHz)
30	TESTA	I	For TEST. Normal time is "H".	60	CONT	O	This output can control at Serial Control from Micro Processor
				61	TEST5	I	For TEST. Normal time is non connection.
				62	CS	I	Chip select Terminal. This terminal "L" : LC7866 is active (Internal Resistor : Pull Down)
				63	XIN	I	Connection Terminal of crystal oscillation (16.9344MHz)
				64	XOUT	O	Connection Terminal of crystal oscillation (16.9344MHz)

IC202 LA3361 (PLL FM MPX. Stereo Demodulator)

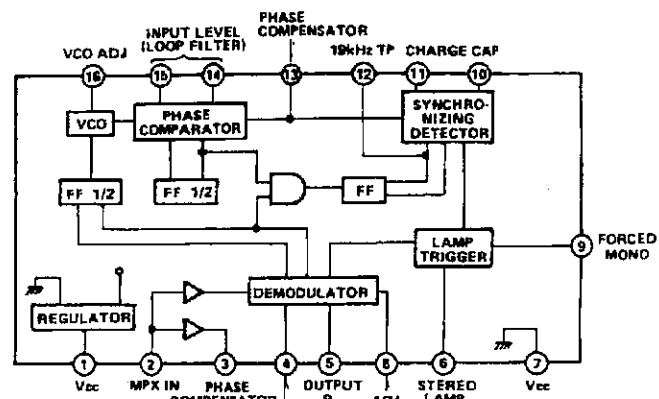

IC203 LM7001 (PLL Frequency Synthesizer)

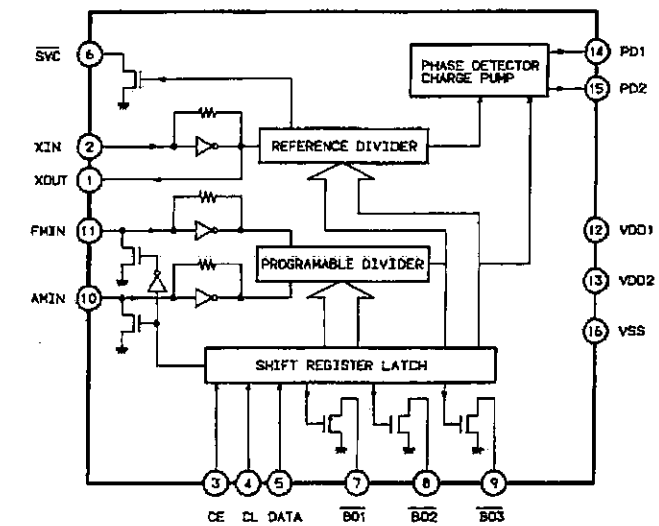

IC BLOCK DIAGRAM

IC105 Pin Function of LC97000-288 (D/A Converter)

No	Pin Name	I/O	Description	No	Pin Name	I/O	Description
1	L-CH	O	DAC CH-1 Output pin.	15	EMPH1	I	De-emphasis set pin.
2	VRH	R	Reference voltage "H" input pin.	16	D/N	I	Normal/Double speed switch pin.
3	AVDD	P	Analog system power supply pin.	17	SOC2	I	Input source select pin.
4	DVDD	P	Digital system power supply pin.	18	SOC1	I	Input source select pin.
5	BCLK	I	Bit clock pin.	19	MODE	I	Operation set pin.
6	DATA	I	Digital audio data input pin. Input in bit serial from MSB.	20	TEST	I	Test pin (Normally "L").
7	LRCK	I	LR Clock input pin. LRCK = "H" CH1 LRCK = "L" CH2	21	TEST	I	Test pin (Normally "L").
8	TEST	I	Test pin (Normally "L").	22	DGND	P	Digital system ground pin.
9	ATT	I	Attenuation data input pin. Input in bit serial from LSB.	23	CLKOUT	O	Clock output pin .. At 392Fs : 1/2 XOUT At 384Fs, 448Fs, 512Fs : 1/4 XOUT
10	SHIFT	I	Attenuation data shift clock input pin.	24	XIN	I	Crystal oscillation input pin.
11	LATCH	I	Attenuation data latch clock input pin.	25	XOUT	O	Crystal oscillation output pin.
12	INITB	I	Initializing signal input pin (Normally "H").	26	AGND	P	Analog system ground pin.
13	TEST	I	Test pin (Normally "L").	27	VRL	R	Reference voltage "L" input pin.
14	EMPH2	I	De-emphasis set pin.	28	R-CH	O	DAC CH-2 Output pin.

IC107 Pin Function of CXP5046H-259S (Micro Processor)

No	Pin Name	I/O	Description	No	Pin Name	I/O	Description
1	IR(INT)	I	Remocon signal	33	LDON	O	Laser ON/OFF signal
2	IR	I	Remocon signal	34	CLOSE	O	Tray action motor (SLED MOTOR) signal
3	REC SW	I	REC (TAPE DECK) signal (ON/OFF) DUB IN	35	OPEN	O	Tray action motor (SLED MOTOR) signal
4	DIR SW	I	Tape Direction (TAPE DECK) signal (A/B)	36	XTAL	O	Clock oscillation signal
5	SYNC	O	Synchronous REC signal (Auto Function output)	37	EXTAL	I	Clock oscillation signal
6	NC		Non used	38	RST	I	Reset signal
7	NC		Non used	39	CQCK	O	Clock signal to LC7866E
8	NC		Non used	40	COIN	O	Command data signal to LC7866E
9	NC		Non used	41	NC		Non used
10	SCAN0	O	Scan signal for key & display	42	SQOUT	I	SUBQ data signal from LC6866E
11	SCAN1	O	Scan signal for key & display	43	RWC	O	RWC signal to LC7866E
12	SCAN2	O	Scan signal for key & display	44	NC		Non used
13	SCAN3	O	Scan signal for key & display	45	WRQ	I	WRQ signal from LC7866E
14	KEY0	I	Key signal	46	DRF	I	DRF signal from LA9210M
15	KEY1	I	Key signal	47	NC		Non used
16	KEY2	I	Key signal	48	CMOPN	I	Open switch signal (ON/OFF)
17	KEY3	I	Key signal	49	LIMIT	I	Pick-up Limit switch signal (ON/OFF)
18	SEGF	O	Segment signal for LED display	50	NC		Non used
19	SEGA	O	Segment signal for LED display	51	NC		Non used
20	SEGB	O	Segment signal for LED display	52	NC		Non used
21	SEGG	O	Segment signal for LED display	53	NC		Non used
22	SEGH	O	Segment signal for LED display	54	NC		Non used
23	SEGC	O	Segment signal for LED display	55	NC		Non used
24	SEGD	O	Segment signal for LED display	56	SLOP	O	Tray action motor (SLED MOTOR) signal
25	SEGE	O	Segment signal for LED display	57	SLO	O	Tray action motor (SLED MOTOR) signal
26	NC		Non used	58	NC		Non used
27	NC		Non used	59	SLC	O	Tray action motor (SLED MOTOR) signal
28	NC		Non used	60	NC		Non used
29	NC		Non used	61	NC		Non used
30	CLV G	O	Select signal of CLV gain	62	NC		Non used
31	NC		Non used	63	NC		Non used
32	VSS		GND	64	Vdd		Power supply (+5V)

IC701 - 703 LA6458S (Dual Operational Amplifier)

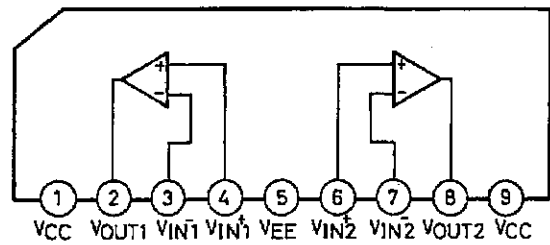

IC751 LA6458D (Dual Operational Amplifier)

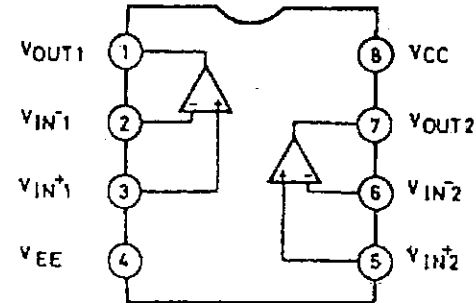

IC BLOCK DIAGRAM

IC702 - 802 BU4051B (8-Channel Multiplexer / De-Multiplexer)

CONTROL INPUTS			"ON" CHANNEL			
INHIBIT	C ^A	B	A	TC4051BP	TC4052BP	TC4053BP
L	L	L	L	0	0X, 0Y	0X, 0Y, 0Z
L	L	L	H	1	1X, 0Y	1X, 0Y, 0Z
L	L	H	L	2	2X, 2Y	0X, 1Y, 0Z
L	L	H	H	3	3X, 3Y	1X, 1Y, 0Z
L	H	L	L	4	---	0X, 0Y, 1Z
L	H	L	H	5	---	1X, 0Y, 1Z
L	H	H	L	6	---	0X, 1Y, 1Z
L	H	H	H	7	---	1X, 1Y, 1Z
H	X	X	X	NONE	NONE	NONE

※ Don't care, △ Except TC4052BP

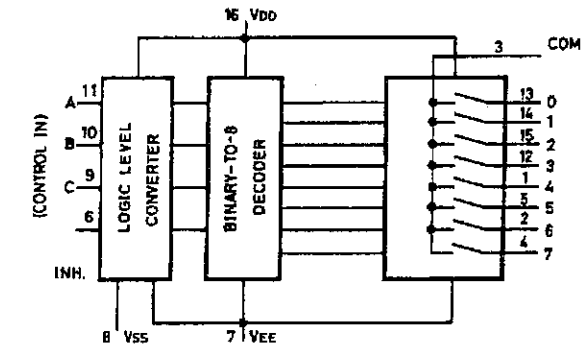

IC752 STK4132MK-2 (Power Amplifier)

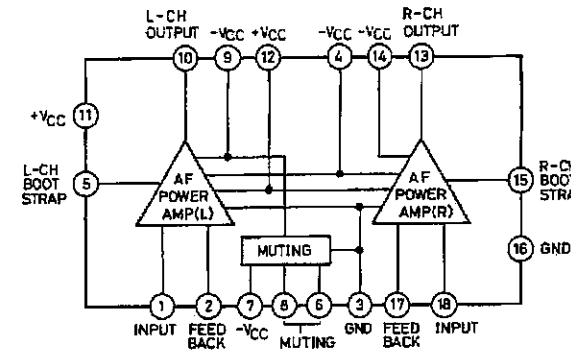

IC902 LB1433N (LED Level Meter Driver)

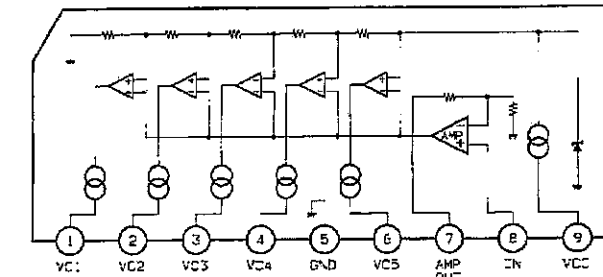

IC951 L780512 (5-Terminal Voltage Regulator)

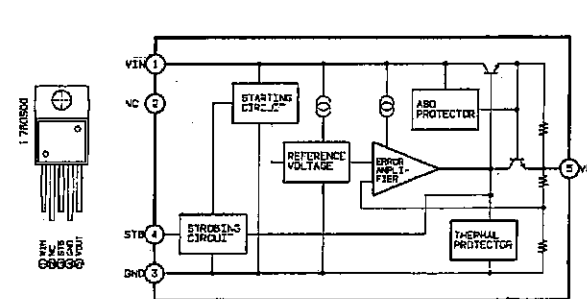

IC952 L7812ML (3-Terminal Voltage Regulator)

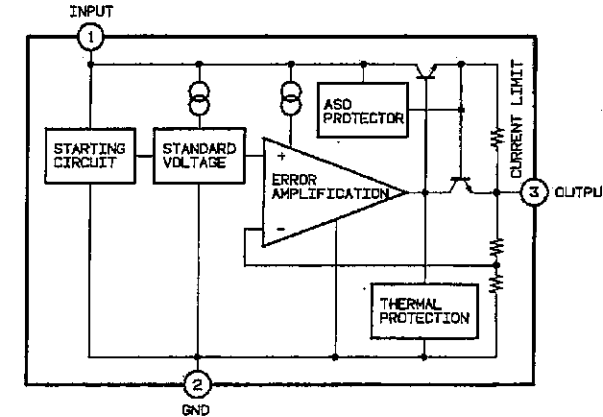

IC BLOCK DIAGRAM

IC500 Pin Function of HD404729A40S (Micro Processor)

No	Pin Name	I/O	Description	No	Pin Name	I/O	Description
1	S OUT 13	O	FL TUBE SEGMENT OUTPUT 13, KEY SCAN OUTPUT 4	32	V _{DD}	-	POWER SUPPLY
2	S OUT 12	O	FL TUBE SEGMENT OUTPUT 12, KEY SCAN OUTPUT 3	33	CLK	O	CLOCK OUTPUT for ISSUE to TUNER PLL IC
3	S OUT 11	O	FL TUBE SEGMENT OUTPUT 11, KEY SCAN OUTPUT 2	34	CE	O	CHIP ENABLE OUTPUT to TUNER PLL IC
4	S OUT 10	O	FL TUBE SEGMENT OUTPUT 10, KEY SCAN OUTPUT 1	35	DATA	O	DATA OUTPUT to TUNER PLL IC
5	S OUT 9	O	FL TUBE SEGMENT OUTPUT 9, KEY SCAN OUTPUT 0	36	AMP CONT	O	AMP, SPEAKER RELAY, ∞ MUTE, 20dB MUTE CONTROL OUTPUT
6	G OUT 1	O	FL TUBE GRID OUTPUT 1	37	KEY IN 1	I	KEY MATRIX INPUT 1
7	G OUT 2	O	FL TUBE GRID OUTPUT 2	38	KEY IN 2	I	KEY MATRIX INPUT 2
8	G OUT 3	O	FL TUBE GRID OUTPUT 3	39	KEY IN 3	I	KEY MATRIX INPUT 3
9	G OUT 4	O	FL TUBE GRID OUTPUT 4	40	KEY IN 4	I	KEY MATRIX INPUT 4
10	G OUT 5	O	FL TUBE GRID OUTPUT 5	41	VOL UP	O	VOLUME UP OUTPUT
11	G OUT 6	O	FL TUBE GRID OUTPUT 6	42	VOL DWN	O	VOLUME DOWN OUTPUT
12	C STOP	O	CD STOP CONTROL SIGNAL OUTPUT H: STOP	43	KEY IN 5	I	KEY MATRIX INPUT 5
13	DUB	O	CD TAPE DUBBING RECORD CONTROL SIGNAL OUTPUT H: L: CD START	44	KEY IN 6	I	KEY MATRIX INPUT 6
14	REEL B	I	TAPE B REEL ROTATION PULSE INPUT	45	KEY IN 7	I	KEY MATRIX INPUT 7
15	REEL A	I	TAPE A REEL ROTATION PULSE INPUT	46	KEY IN	I	KEY MATRIX INPUT 8
16	MOTOR	O	TAPE MOTOR SELECT OUTPUT H: ON L: OFF	47	H RESET	I	HARD RESET INPUT
17	M H/L	O	TAPE MOTOR SPEED SELECT OUTPUT H: LOW L: HIGH	48	X'TAL OSC	O	CRYSTAL OSCILLATION OUTPUT
18	IR	I	INFRARED REMOCON RECEIVING SIGNAL INPUT TAPE ACTION STATUS INDICATION LED OUTPUT	49	X'TAL OSC	I	CRYSTAL OSCILLATION INPUT
19	V _{DISP}	I	POWER SUPPLY FOR FL DISPLAY	50	V _{SS}	-	GND
20	PLUNG	O	PLUNGER ABSORPTION PULSE OUTPUT H: ON	51	N.P.	I	NOT USED
21	R MUTE	O	TAPE RECORD MUTE SIGNAL OUTPUT H: ON L: OFF	52	N.P.	O	NOT USED
22	D R/P	O	TAPE DOLBY-B REC/PLAY SELECT SIGNAL OUTPUT L: PLAY H: REC	53	TEST	-	CHIP TEST
23	OSC	O	TAPE OSC CIRCUIT HEAD SELECT SIGNAL OUTPUT L: OFF, PLAY H: ON, REC	54	P DOWN	I	SERVICE INTERRUPTION DETECT INPUT
24	A/B	O	TAPE ACTION STATUS INDICATION LED OUTPUT H: A L: B	55	S OUT 14	O	FL TUBE SEGMENT OUTPUT 14
25	FOV	O	TAPE ACTION STATUS INDICATION LED OUTPUT	56	S OUT 15	O	FL TUBE SEGMENT OUTPUT 15
26	REV	O	TAPE ACTION STATUS INDICATION LED OUTPUT	57	S OUT 8	O	FL TUBE SEGMENT OUTPUT 8
27	REC	O	TAPE ACTION STATUS INDICATION LED OUTPUT	58	S OUT 7	O	FL TUBE SEGMENT OUTPUT 7
28	FUNC A	O	FUNCTION SELECT SIGNAL A OUTPUT	59	S OUT 6	O	FL TUBE SEGMENT OUTPUT 6
29	FUNC B	O	FUNCTION SELECT SIGNAL B OUTPUT	60	S OUT 5	O	FL TUBE SEGMENT OUTPUT 5
30	FUNC C	O	FUNCTION SELECT SIGNAL C OUTPUT	61	S OUT 4	O	FL TUBE SEGMENT OUTPUT 4
31	OFF	I	POWER SUPPLY VOLTAGE DETECT INPUT (SERVICE INTERRUPTION MODE 1)	62	S OUT 3	O	FL TUBE SEGMENT OUTPUT 3
				63	S OUT 2	O	FL TUBE SEGMENT OUTPUT 2, KEY SCAN OUTPUT 6
				64	S OUT 1	O	FL TUBE SEGMENT OUTPUT 1, KEY SCAN OUTPUT 5

AFUNC A ~ C

	FUNC A	FUNC B	FUNC C
TUN	L	L	L
CD	H	L	L
TAPE	H	L	H
PHONO	L	H	L
AUX 1	H	H	L
AUX 2	H	H	H

AMP CONT

V _{DD}	20dB MUTE	∞ MUTE	SP RY	POWER
75%	OFF	OFF	ON	ON
50%	ON	ON	ON	ON
25%	ON	ON	OFF	ON
V _{SS}	ON	ON	OFF	OFF

IC351 (Dolby B-Type Noise Reduction)

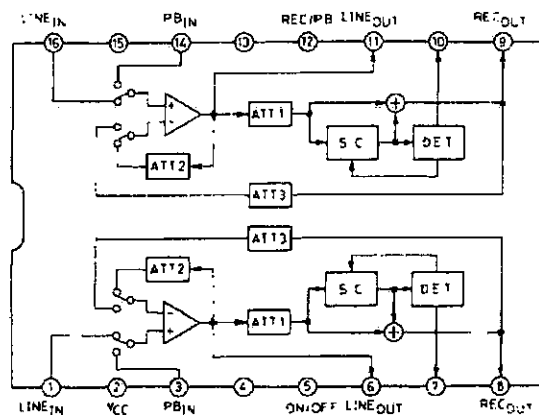

DISPLAY (LCD) PIN DESCRIPTION

FL500 (Tuner Fluorescent Display)

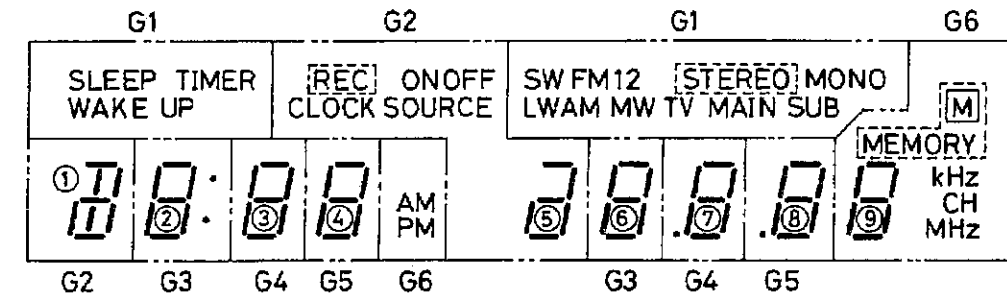

[]: Red, other Blue-green

Segment Map

	S1	S2	S3	S4	S5	S6	S7	S8	S9	S10	S11	S12	S13	S14	S15
G1	AM	SUB	MW	TV	SW	FM	1	2	MAIN	LW	STEREO	MONO	TIMER	SLEEP	WAKEUP
G2	OFF	ON	REC	SOURCE	CLOCK	ⓐ	ⓑ	ⓒ	ⓓ	ⓔ	ⓕ	ⓖ	ⓗ	ⓓ	ⓔ
G3	ⓐ	ⓑ	ⓒ	ⓓ	ⓔ	ⓕ	ⓖ	ⓗ	ⓓ	ⓔ	ⓕ	ⓖ	ⓗ	ⓓ	ⓔ
G4	ⓐ	ⓑ	ⓒ	ⓓ	ⓔ	ⓕ	ⓖ	ⓗ	ⓓ	ⓔ	ⓕ	ⓖ	ⓗ	ⓓ	ⓔ
G5	ⓐ	ⓑ	ⓒ	ⓓ	ⓔ	ⓕ	ⓖ	ⓗ	ⓓ	ⓔ	ⓕ	ⓖ	ⓗ	ⓓ	ⓔ
G6	ⓐ	ⓑ	ⓒ	ⓓ	ⓔ	ⓕ	ⓖ	ⓗ	MEMORY	ⓓ	AM	PM	kHz	CH	MHz

Pin Assignment

PIN No.	1	2	3	4	5	6	7	8	9	10	11	12	13
Segment Name	F	G6	G5	G4	G3	G2	G1	S15	S14	S13	S12	S11	S10
	14	15	16	17	18	19	20	21	22	23	24	25	
	S9	NC	NC	S1	S2	S3	S4	S5	S6	S7	S8	F	

VOLTAGES OF IC (CD)

(Unit : Volt)

IC101 LA9210M

Measuring Pin No.	1	2	3	4	5	6	7	8	9	10	11	12	13	14	15	16
Stop Mode	0	-5.0	0	0	0	0	0	0	0	2.59	2.54	2.55	0	0	0	0
Play Mode	0	-5.0	Fluc	Fluc	Fluc	Fluc	Fluc	0	0	Fluc	Fluc	Fluc	Fluc	Fluc	Fluc	Fluc
Measuring Pin No.	17	18	19	20	21	22	23	24	25	26	27	28	29	30	31	32
Stop Mode	0	0	0	0	Fluc	Fluc	0	0	0	0	Fluc	2.43	0	0	0	-5.0
Play Mode	Fluc	Fluc	Fluc	Fluc	Fluc	Fluc	Fluc	Fluc	0	Fluc	Fluc	Fluc	Fluc	Fluc	Fluc	-5.0
Measuring Pin No.	33	34	35	36	37	38	39	40	41	42	43	44	45	46	47	48
Stop Mode	0	0	0	5.0	4.39	0	0	0	0	0	0	0	4.97	4.92	4.07	4.07
Play Mode	Fluc	Fluc	Fluc	5.0	Fluc	Fluc	Fluc	Fluc	0	Fluc	Fluc	Fluc	Fluc	Fluc	Fluc	Fluc
Measuring Pin No.	49	50	51	52	53	54	55	56	57	58	59	60	61	62	63	64
Stop Mode	4.07	0	0	0	2.52	2.49	2.50	5.0	2.51	2.51	2.54	3.92	2.60	2.33	4.92	0
Play Mode	Fluc	Fluc	Fluc	Fluc	Fluc	Fluc	Fluc	5.0	Fluc	Fluc	Fluc	Fluc	Fluc	Fluc	Fluc	0
Measuring Pin No.	65	66	67	68	69	70	71	72	73	74	75	76	77	78	79	80
Stop Mode	0	0.4	-0.4	0	-0.5	-0.5	0	-0.5	0	4.82	-4.97	4.83	5.0	0	0	0
Play Mode	0	Fluc	Fluc	Fluc	Fluc	Fluc	0	Fluc	Fluc	Fluc	Fluc	Fluc	5.0	Fluc	Fluc	0

IC102 LC6510

Measuring Pin No.	1	2	3	4	5	6	7	8	9	10
Stop Mode	Fluc	Fluc	Fluc	Fluc	-9.65	Fluc	Fluc	Fluc	Fluc	8.60
Play Mode	Fluc	Fluc	Fluc	Fluc	-9.65	Fluc	Fluc	Fluc	Fluc	8.60

Fluc : Fluctuation

IC103 LC6510

Measuring Pin No.	1	2	3	4	5	6	7	8	9	10
Stop Mode	0	0	0	0	-9.65	0	Fluc	Fluc	Fluc	8.60
Play Mode	Fluc	Fluc	0	0	-9.65	0	Fluc	Fluc	Fluc	8.60

IC104 LC7866E

Measuring Pin No.	1	2	3	4	5	6	7	8	9	10	11	12	13	14	15	16
Stop Mode	0	2.31	2.34	2.51	0	2.46	2.48	2.52	0	0	0	4.92	0	2.51	4.07	4.07
Play Mode	Fluc	Fluc	Fluc	Fluc	0	Fluc	Fluc	Fluc	Fluc	Fluc	Fluc	Fluc	Fluc	Fluc	Fluc	Fluc
Measuring Pin No.	17	18	19	20	21	22	23	24	25	26	27	28	29	30	31	32
Stop Mode	4.07	2.5	0	4.95	4.97	0	0	5.0	0	0	0	0	5.0	1.25	1.25	1.25
Play Mode	Fluc	Fluc	Fluc	Fluc	Fluc	Fluc	Fluc	5.0	Fluc	Fluc	Fluc	Fluc	Fluc	5.0	Fluc	Fluc
Measuring Pin No.	33	34	35	36	37	38	39	40	41	42	43	44	45	46	47	48
Stop Mode	2.5	2.5	0	2.5	0	2.5	2.41	1.63	2.5	4.5	2.52	Fluc	2.28	0	2.5	0
Play Mode	Fluc	Fluc	Fluc	Fluc	Fluc	Fluc	Fluc	0(4.5)	Fluc	Fluc	Fluc	Fluc	Fluc	Fluc	Fluc	Fluc
Measuring Pin No.	49	50	51	52	53	54	55	56	57	58	59	60	61	62	63	64
Stop Mode	2.5	Fluc	Fluc	Fluc	0	5.0	4.48	0	4.92	Fluc	2.33	4.93	0	0	2.28	2.47
Play Mode	Fluc	Fluc	Fluc	Fluc	0	5.0	Fluc	0	Fluc	Fluc	Fluc	Fluc	Fluc	0	Fluc	Fluc

IC105 LC97000P-288

Measuring Pin No.	1	2	3	4	5	6	7	8	9	10	11	12	13	14	15	16
Stop Mode	2.06	4.02	5.0	5.0	2.5	0	2.5	0	0	0	0	4.93	0	0	0	0
Play Mode	Fluc	Fluc	Fluc	Fluc	5.0	Fluc	Fluc	0	0	0	0	Fluc	0	0	Fluc	0
Measuring Pin No.	17	18	19	20	21	22	23	24	25	26	27	28				
Stop Mode	0	0	0	0	0	0	2.19	0.55	2.79	0	0	0				
Play Mode	0	0	0	0	0	0	Fluc	Fluc	Fluc	0	0	Fluc				

IC106 XRA15218F

Measuring Pin No.	1	2	3	4	5	6	7	8
Stop Mode	2.05	2.05	0	-5.0	2.06	2.06	2.06	5.0
Play Mode	Fluc	Fluc	Fluc	-5.0	Fluc	Fluc	Fluc	5.0

IC107 M5294P

Measuring Pin No.	1	2	3	4	5	6	7	8	9	10	11	12	13	14	15	16
Stop Mode	-9.65	0	-5.0	0	-9.65	-7.84	3.41	1.04	5.0	1.06	0.59	5.0	8.60	5.0	1.24	8.60
Play Mode	-9.65	Fluc	-5.0	0	-9.65	Fluc	Fluc	Fluc	5.0	Fluc	Fluc	5.0	8.50	5.0	Fluc	8.60

IC108 CXP5046-259

Measuring Pin No.	1	2	3	4	5	6	7	8	9	10	11	12	13	14	15	16
Stop Mode	5.0	5.0	0	5.0	5.0	5.0	5.0	5.0	5.0	5.0	Fluc	Fluc	Fluc	5.0	5.0	5.0
Play Mode	5.0	5.0	0	5.0	5.0	5.0	5.0	5.0	5.0	5.0	Fluc	Fluc	Fluc	5.0	5.0	5.0
Measuring Pin No.	17	18	19	20	21	22	23	24	25	26	27	28	29	30	31	32
Stop Mode	5.0	5.0	5.0	Fluc	5.0	Fluc	Fluc	5.0	5.0	0	0	0	0	0	0	0
Play Mode	5.0	5.0	5.0	Fluc	5.0	Fluc	Fluc	5.0	5.0	0	0	0	0	0	0	0
Measuring Pin No.	33	34	35	36	37	38	39	40	41	42	43	44	45	46	47	48
Stop Mode	5.0	0	5.0	Fluc	Fluc	5.0	5.0	0	0	Fluc	Fluc	5.0	Fluc	4.2	5.0	5.0
Play Mode	0	5.0	0	Fluc	Fluc	5.0	5.0	0	0	Fluc	Fluc	5.0	Fluc	4.2	5.0	5.0
Measuring Pin No.	49	50	51	52	53	54	55	56	57	58	59	60	61	62	63	64
Stop Mode	5.0	5.0	5.0	5.0	5.0	5.0	5.0	0	0	0	0	0	0	0	0	0
Play Mode	5.0	5.0	5.0	5.0	5.0	5.0	5.0	0	0	0	0	0	0	0	0	0

Pin 35 : Close Pin 36 : Open

VOLTAGES OF TRANSISTOR (CD)

(Unit : Volt)

TRANSISTOR

Transistor No.	Q101			Q102			Q103			Q105		
Measuring Pin Name	E	C	B	E	C	B	E	C	B	E	C	B
Stop Mode	4.97	0	4.82	2.54	2.60	2.57	0	5.0	0	4.02	5.0	4.6
Play Mode	4.0	1.0	4.0	Fluc	Fluc	Fluc	0	5.0	0	4.02	5.0	4.6
Transistor No.	Q111			Q112			Q11B					
Measuring Pin Name	E	C	B	E	C	B	E	C	B			
Stop Mode	5.0	0	5.0	Fluc	5.0	0	0	0	0			
Play Mode	5.0	5.0	0	Fluc	5.0	0	0	0	0			

SCHEMATIC DIAGRAM (TAPE MECHANISM)

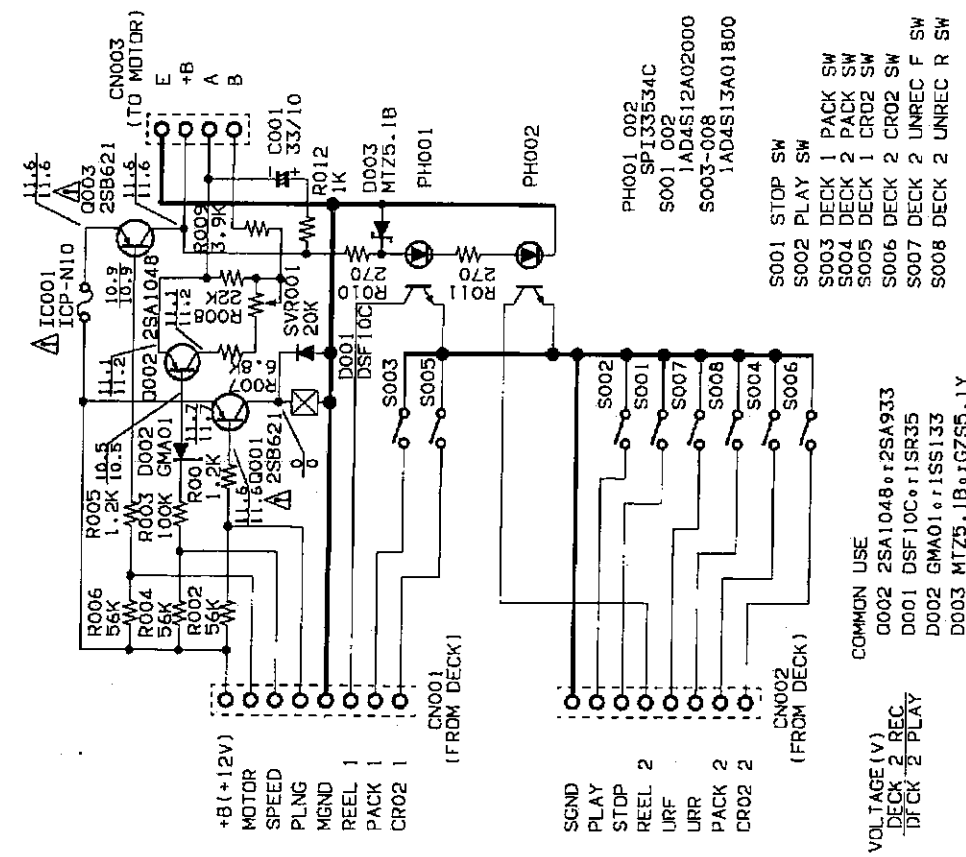

COMMON USE
 C002 2SA1048 or 2SA933
 C001 DSF10C or 1SR35
 C002 GMA01 or ISS133
 C003 MT25.1B or 6ZS5.1Y

SCHEMATIC DIAGRAM (CD)

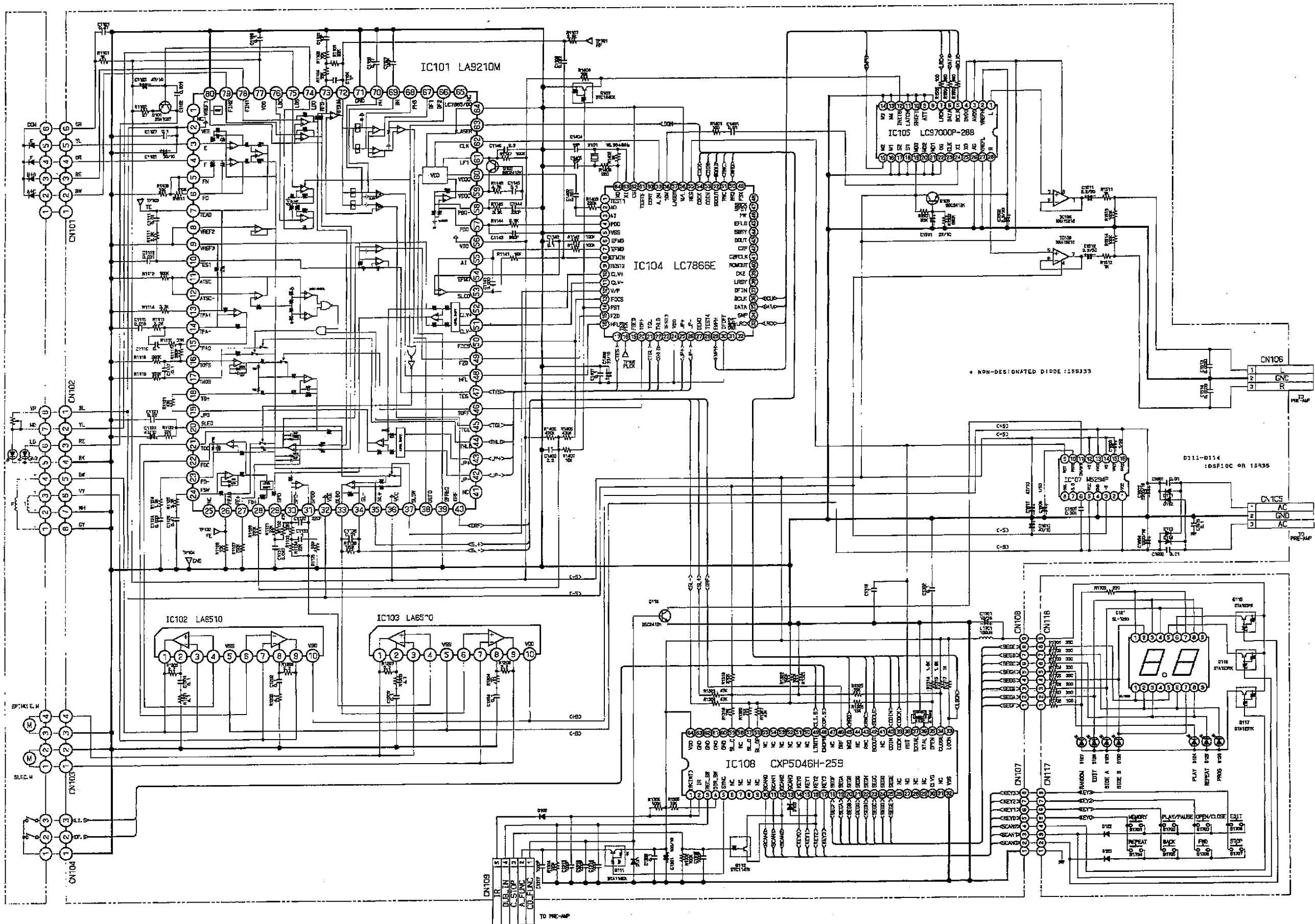

WIRING DIAGRAM (CD)

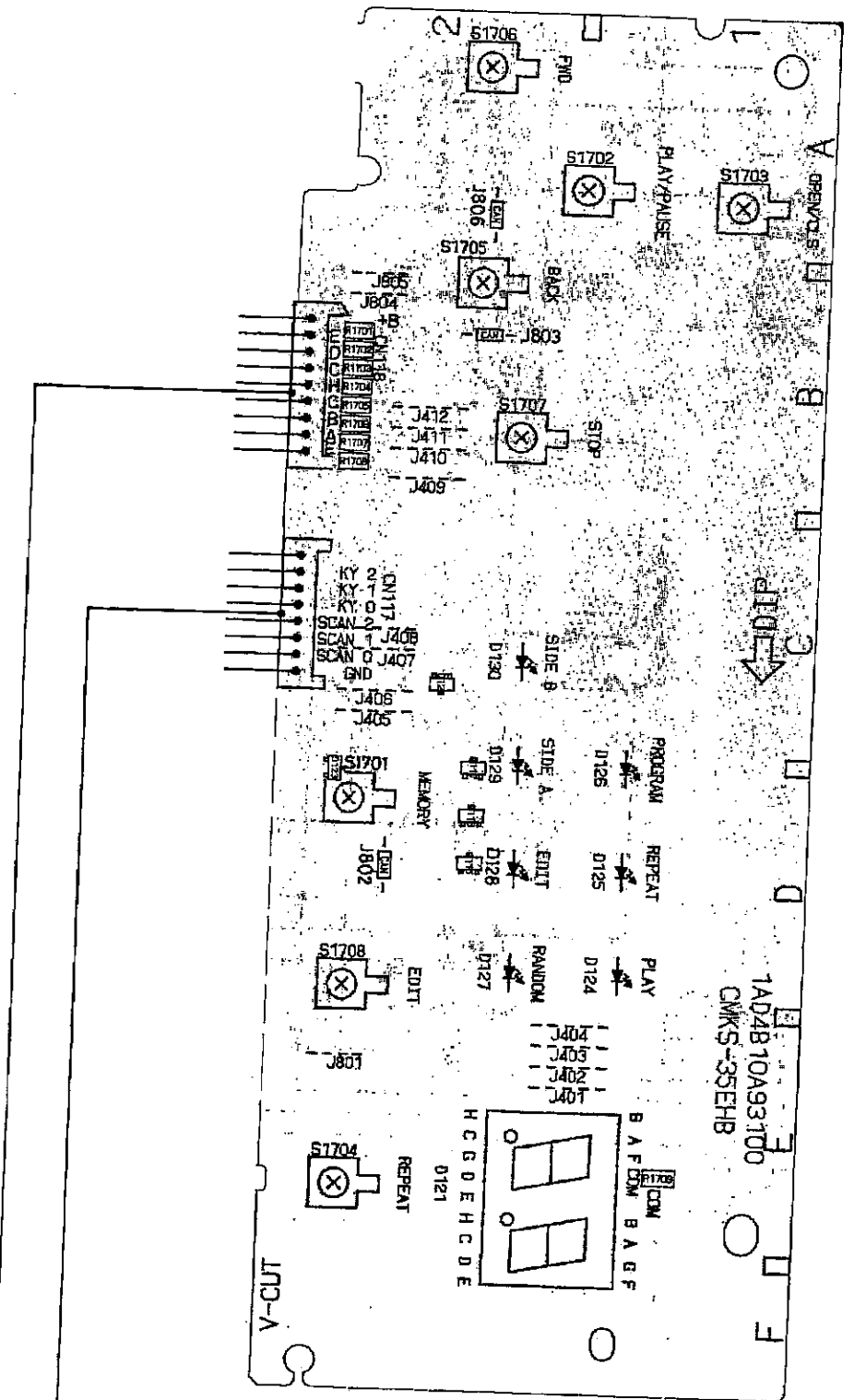
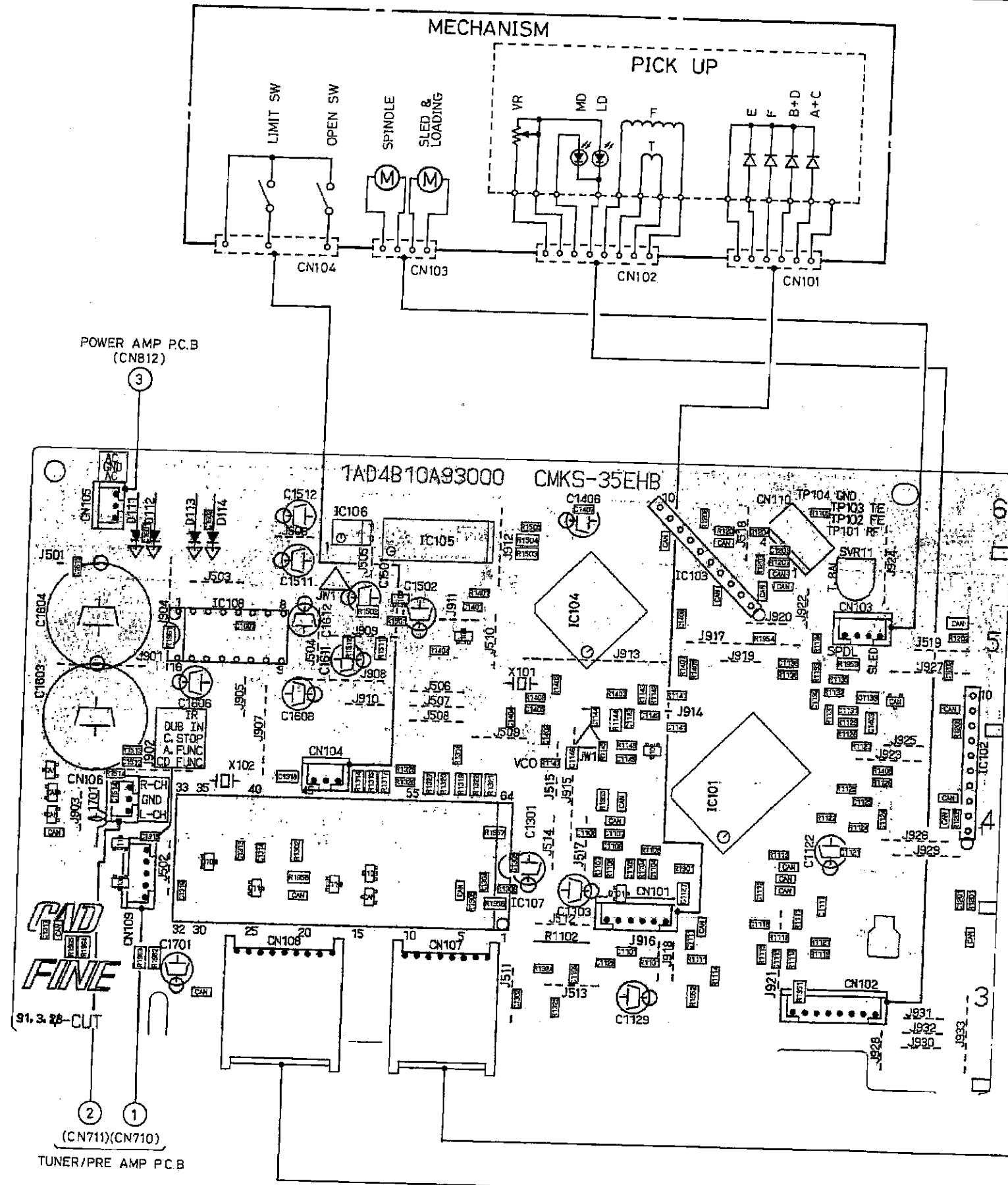

CHEMATIC DIAGRAM (TUNER)

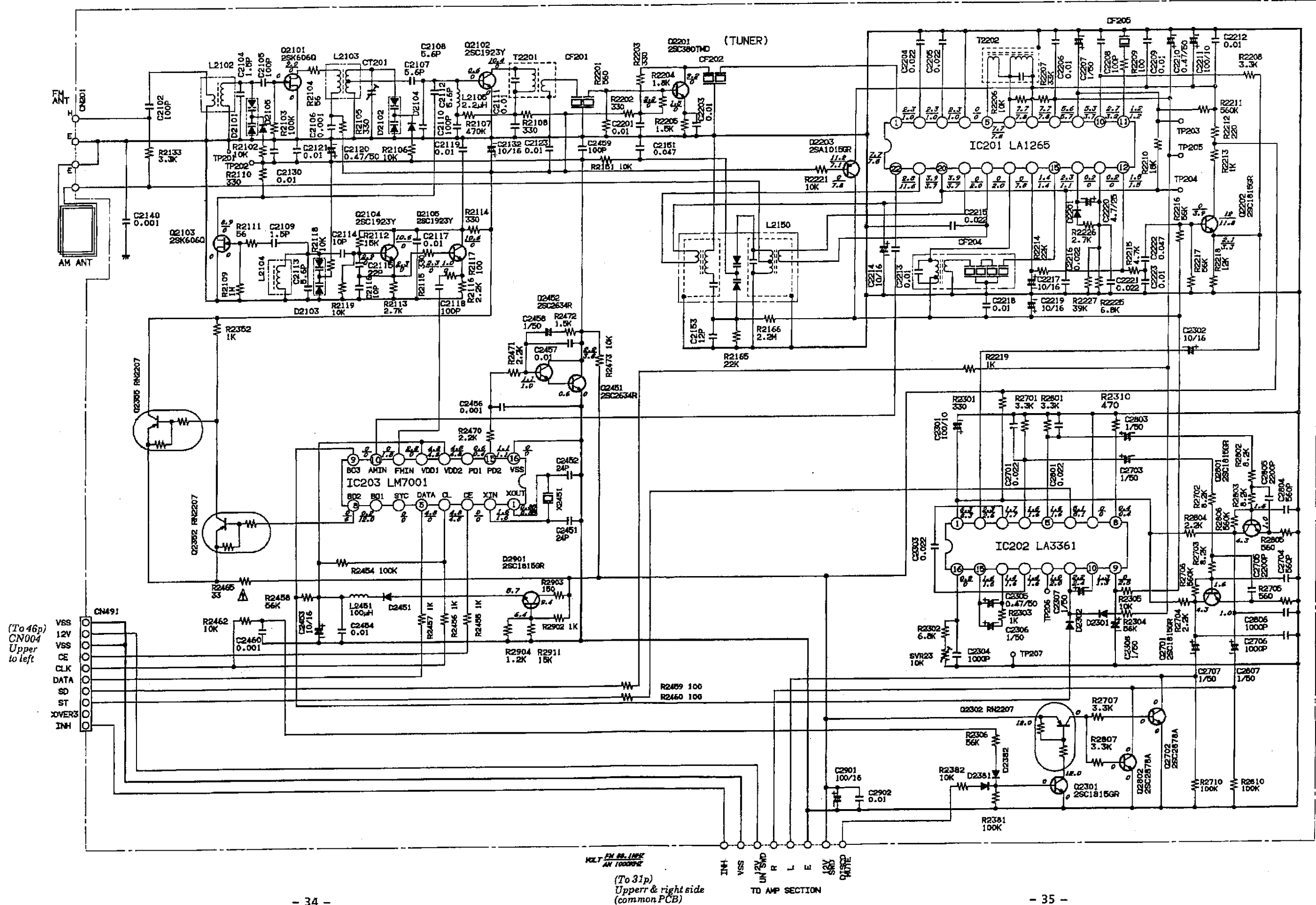

WIRING DIAGRAM (TUNER & PRE-AMPLIFIER)

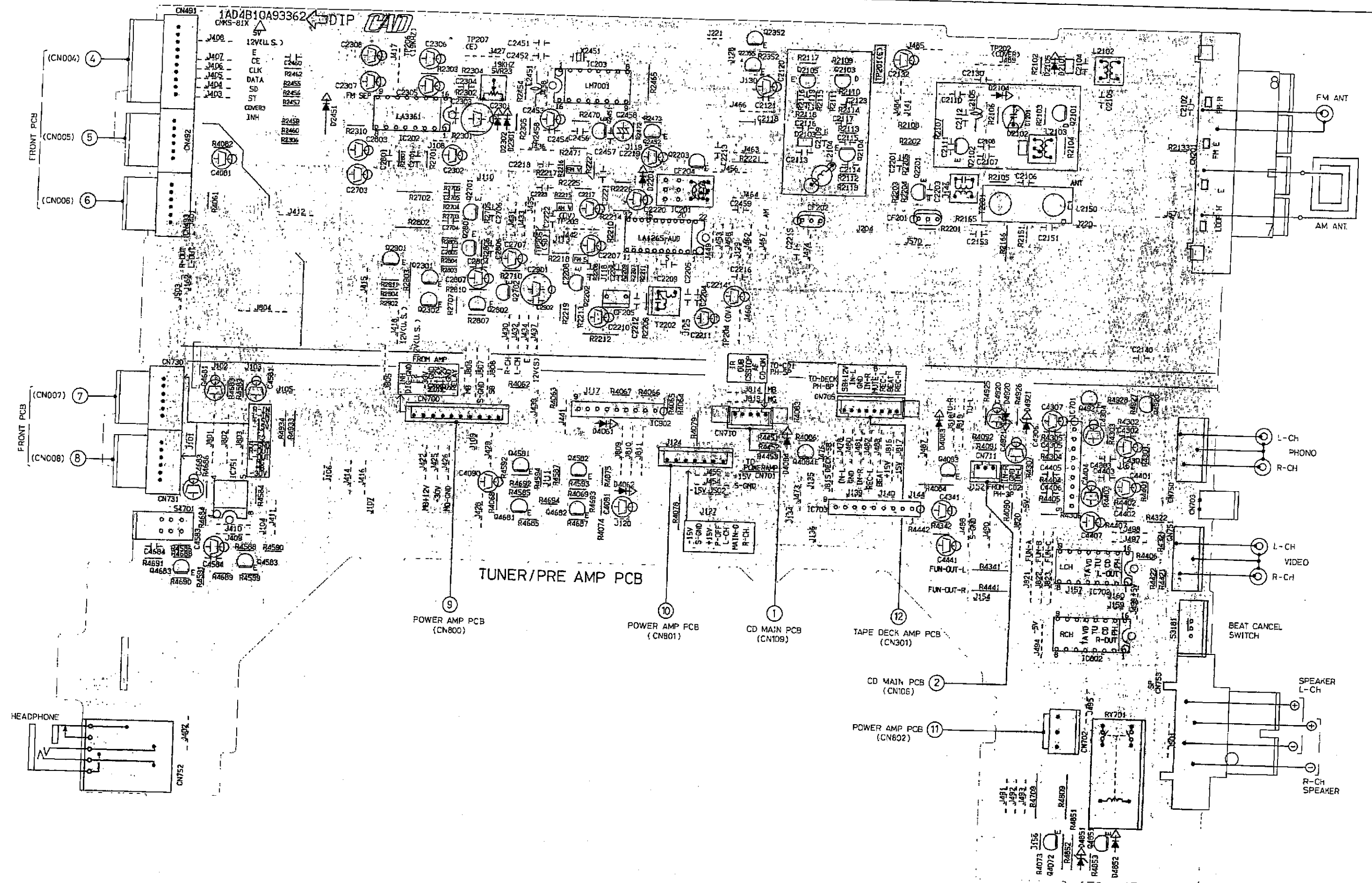

SCHEMATIC DIAGRAM (TAPE DECK AMPLIFIER)

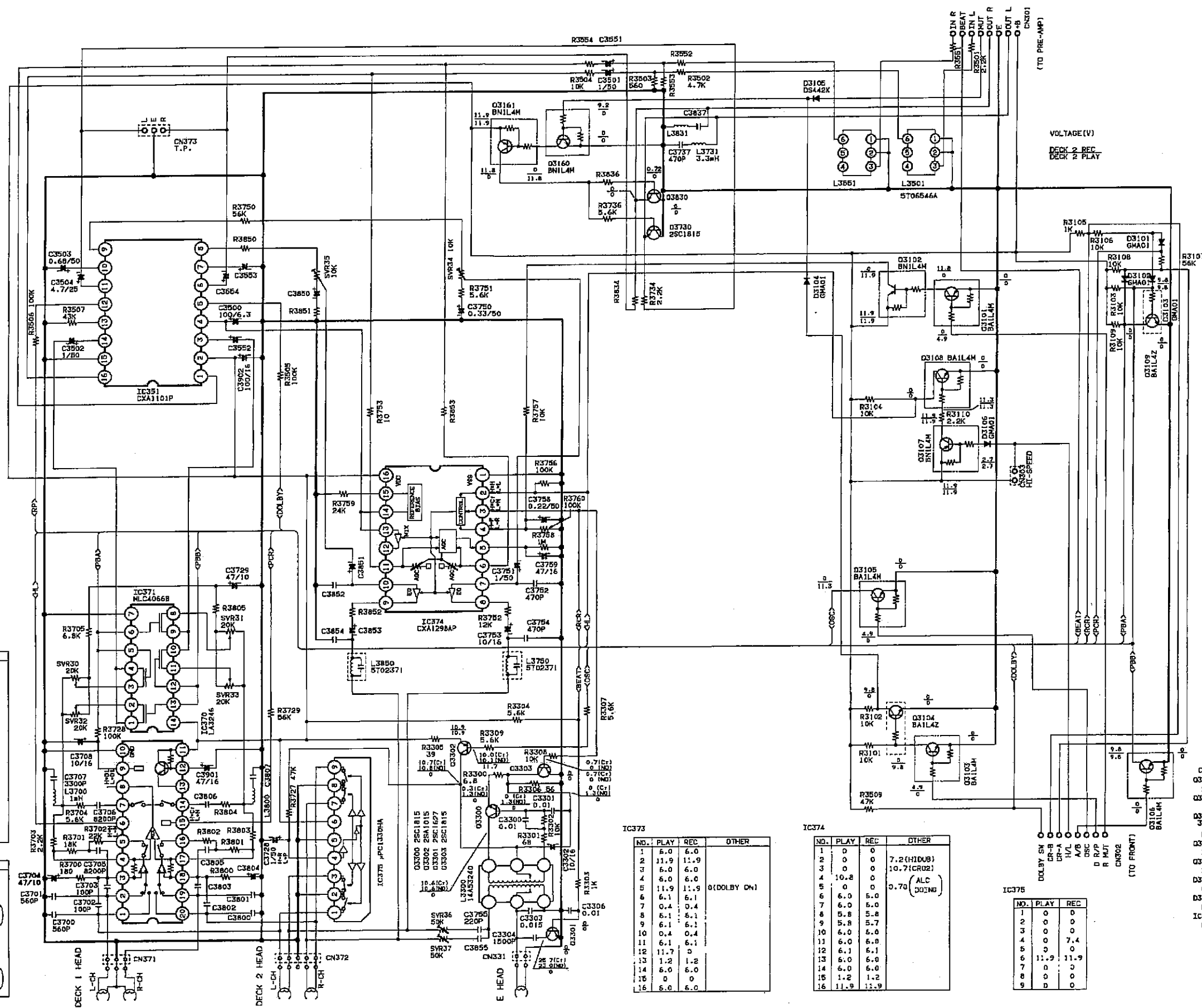

IC370

NO.	PLAY	REC	OTHER
1	0	0	
2	0	0	
3	0.56	0.56	
4	5.3	5.3	
5	5.3	5.3	
6	0	0	5.5 (HIDUB)
7	0	0	
8	5.2	5.2	
9	0	0	6.7 (DECK 1 PLAY)
10	0	0	
11	11.9	11.9	
12	11.6	11.6	
13	11.0	11.0	
14	0	0	
15	0.60	0.60	5.5 (CR02)
16	5.1	5.1	
17	5.1	5.1	
18	0.56	0.56	
19	0	0	
20	0	0	

IC371

NO.	PLAY	REC	OTHER
1	5.2	5.2	
2	5.2	5.2	
3	5.2	5.2	
4	5.2	5.2	
5	0	0	11.4 (DECK 1)
6	0	0	11.4 (PLAY)
7	0	0	
8	5.2	5.2	
9	5.2	5.2	
10	5.2	5.2	
11	5.2	5.2	
12	9.8	9.8	0 (DECK 1)
13	9.8	9.8	
14	11.9	11.9	

IC373

NO.	PLAY	REC	OTHER
1	5.0	6.0	
2	11.9	11.9	
3	6.0	6.0	
4	6.0	6.0	
5	11.9	11.9	0 (DOLBY ON)
6	6.1	6.1	
7	0.4	0.4	
8	6.1	6.1	
9	6.1	6.1	
10	0.4	0.4	
11	6.1	6.1	
12	11.7	0	
13	1.2	1.2	
14	6.0	6.0	
15	0	0	
16	6.0	6.0	

IC374

NO.	PLAY	REC	OTHER
1	0	0	
2	0	0	7.2 (HIDUB)
3	0	0	10.7 (CR02)
4	10.8	0	
5	0	0	0.70 (ALC) (DQNG)
6	6.0	6.0	
7	6.0	6.0	
8	5.8	5.8	
9	5.8	5.7	
10	6.0	6.0	
11	6.0	6.0	
12	6.1	6.1	
13	5.0	6.0	
14	6.0	6.0	
15	1.2	1.2	
16	11.9	11.9	

IC375

NO.	PLAY	REC
1	0	0
2	0	0
3	0	0
4	0	0
5	0	0
6	0	0
7	0	0
8	0	0
9	0	0
10	0	0
11	0	0
12	0	0
13	0	0
14	0	0
15	0	0
16	0	0

- COMMON USE
 Q3730 3836 3300 3303
 25C1815+25C945
 Q3302
 25A1015+25A733
 Q3101 3103 3105 3106 3108 3160
 RN1204+R14L4M
 Q3102 3107 3161
 RN204+RN1L4M
 BAIL4Z
 Q3104 3109
 BAIL4Z
 Q3101 3102 3103 3104 3105
 GMA01+15S133
 D3105
 DS442X+152473
 IC371
 M.C4066B+TC4066BP
 BU4066B+PD4066BC

SCHEMATIC DIAGRAM (FRONT)

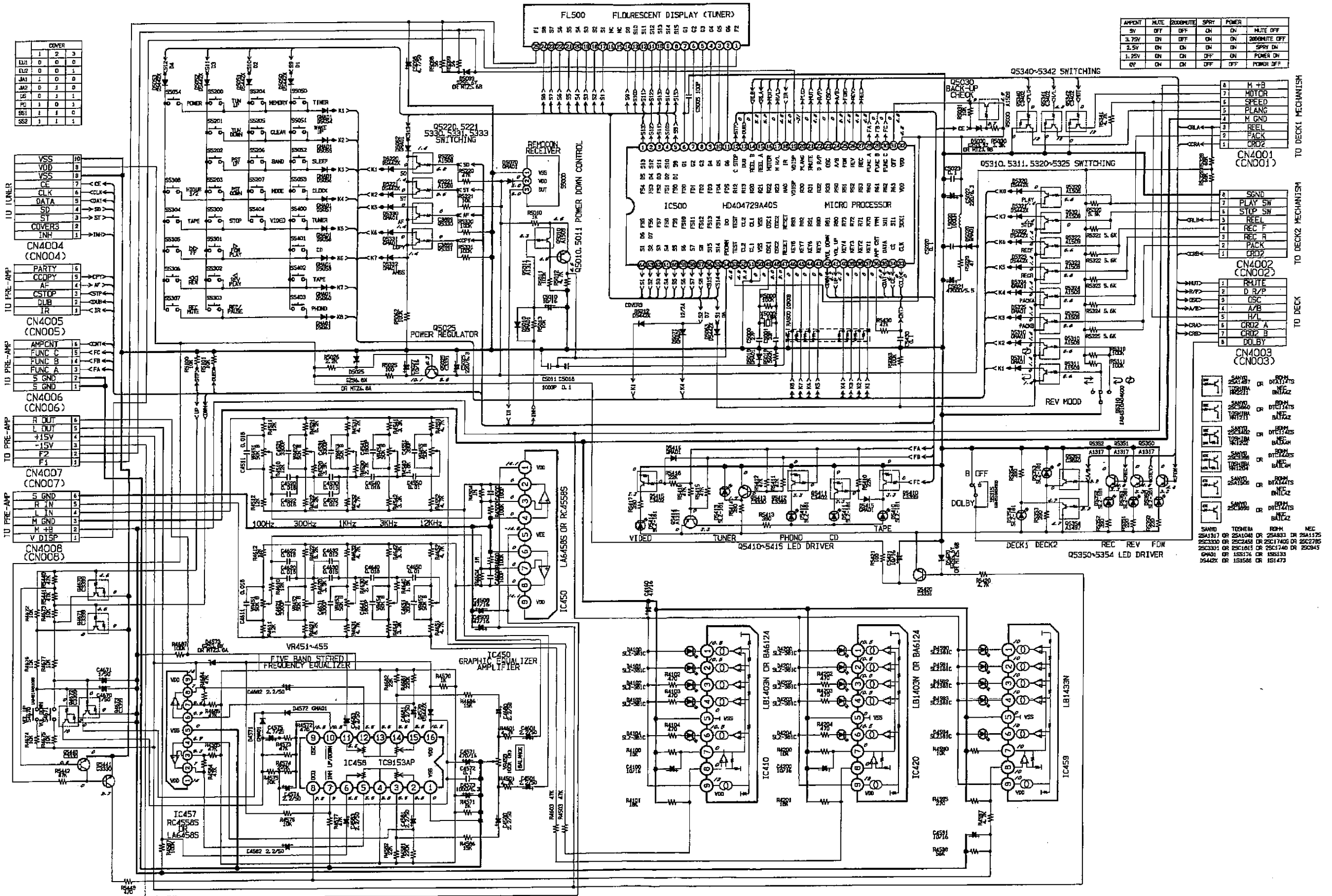

COVER			
EL1	1	2	3
EL2	0	0	0
EL3	0	0	1
EL4	1	0	0
EL5	1	0	1
EL6	1	1	0
EL7	1	1	1

APPCNT	MUTE	2000MUTE	SPRY	POWER	MUTE OFF
5V	OFF	OFF	ON	ON	MUTE OFF
3.75V	ON	OFF	ON	ON	2000MUTE OFF
3.5V	ON	ON	ON	ON	SPRY ON
1.25V	ON	ON	OFF	ON	POWER ON
0V	ON	ON	OFF	OFF	POWER OFF

CN4001 (CN001)	
1	CR02
2	PACK
3	REEL F
4	M GND
5	PLANG
6	SPEED
7	MOTOR
8	M +B

CN4002 (CN002)	
1	CR02 B
2	CR02 A
3	H/L
4	A/B
5	OSC
6	D R/P
7	MUTE
8	DOLBY

CN4003 (CN003)	
1	REV
2	STOP
3	PLAY
4	SEND

SAWAD	TOSHIBA	ROHM	NEC
2SA1317	2SA1048	2SA833	2SA1175
2SC3300	2SC2428	2SC1740	2SC2726
2SC3301	2SC1916	2SC1740	2SC2945
2SA1	15S174	15S133	
2SA2	15S156	151473	

WIRING DIAGRAM (FRONT)

FRONT PCB

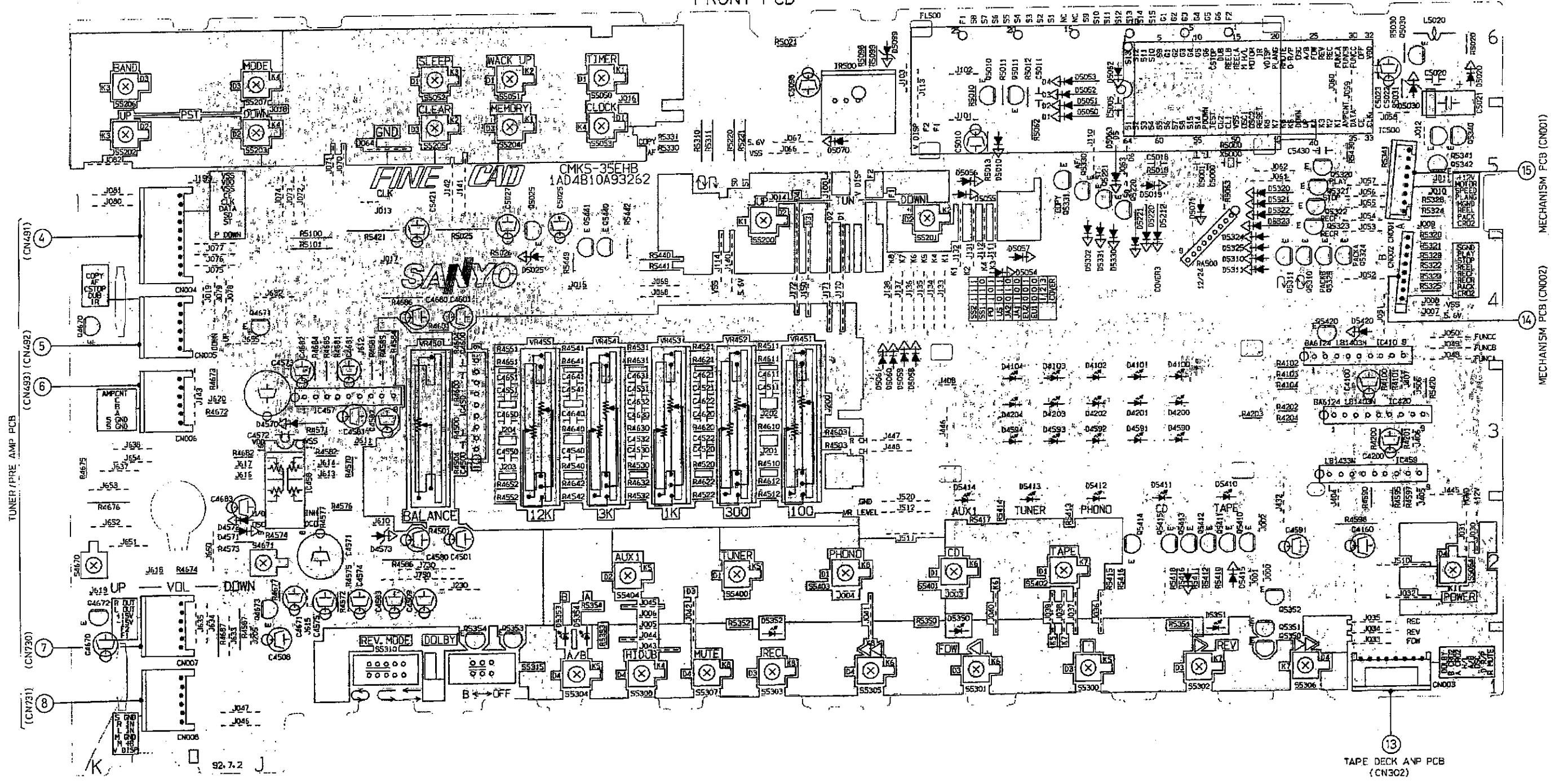



Notice

- CORRECTION PRODUCTION CHANGE
 SERVICE FLASH ADD INFORMATION

FILE NO. E-2497

Please add this notice to the Service Manual listed below.

Category : <u>CD Stereo Sound System</u>	Date : Aug. 1993
Model : <u>DC-X900</u>	
Destination : <u>AU</u>	Reference No. : <u>SM580036</u>
	Issue Number : <u>1</u>

The reason of change.

A : Misprint
D : Design
G :

B : Quality Reliabilities
E :

C : Standardization
F :

Page & Section	Ref. No.		Part No.	Description	Q'ty	Interchangeability	Reason
CABINET & CHASSIS P10	6	Old	614 228 4001	PANEL,SIDE,L	1	NO	A
	6	New	614 228 4018	PANEL,SIDE,L	1	NO	A
	7	Old	614 228 4018	PANEL,SIDE,R	1	NO	A
	7	New	614 228 4001	PANEL,SIDE,R	1	NO	A

Prod. Cord : 129 353 10 AU

SANYO Electric Co., Ltd.
Osaka, Japan