



255

# SANYO STEREO TURNTABLE TP 625 <sup>(MV)</sup> <sub>(SEV)</sub> <sub>(UK)</sub> SERVICE MANUAL



Model TP625 (MV, UK)



Model TP625 (SEV)

255

## SPECIFICATIONS

### MOTOR & TURNTABLE SECTION

Motor	4-pole synchronous motor
Drive System	Belt-driven
Speeds	33-1/3 and 45 rpm.
Wow and Flutter	0.08%
Signal to Noise Ratio @2f	48 dB
Turntable Platter	Aluminum alloy die-cast
Diameter	300 mm (11-13/16 inch)
Weight	1.0 kg (2 lb. 3 oz.)

### TONE ARM SECTION

Type	Static-balance type (S-shape)
Effective Arm Length	215 mm (8-1/2 inch)
Tracking Error	+3°, -1°
Tracking Force Range	0.5 to 3.5 g
Max. Usable Cartridge	
Weight w/Headshell	20 g

### CARTRIDGE SECTION

Type	Induced Magnetic (MG-28)
Frequency Response	10 – 27K

### Channel Separation

@ 1,000 Hz	15 dB
Output Voltage @ 50mm/sec.	2.0 – 3.8 mV
Load Impedance	50 K $\Omega$
Stylus	0.5 mill. Diamond (ST-28D)
Compliance @ 1,000Hz	5.1 x 10 <sup>-6</sup> cm/dyne
Tracking Force	1.5 – 2.5 g
Weight	6.0 g

### MISCELLANEOUS

Power Requirement	MV (Switchable) 120/200/220/240 V 50/60 Hz SEV 110V/220V 50Hz UK 240V 50Hz
Power Consumption	12.0 watts
Dimension	Wide 452 mm Depth 366 mm Height 168 mm
Weight	7.8 Kg (Approx)

NOTE: Specifications are subject to change without notice for further improvement.

## ADJUSTMENT

### PICK-UP ARM HEIGHT ADJUSTMENT

Loosen the pick-up arm height adjusting screw (103) and adjust the height by sliding the support arm (102) and secure the screw.

### PICK-UP RAISING POSITION ADJUSTMENT (Return point)

Turn screw 139 clockwise to move outwards, and counterclockwise to move inwards.

# PARTS LIST (TP625 MV)

Key No.	Part No.	Description	Q'ty	Key No.	Part No.	Description	Q'ty
<b>PACKING</b>				<b>CABINET</b>			
	131 6 1139 51714	Box, Corrugate Exp	1	18	106 3 1103 11301	Screw, Round HD WD + 3.1 x 13	1
	131 6 2119 01330	Bag, Polyethylene Exp-Lid	1	20	131 2 1107 18900	Lid	1
	131 6 2119 01361	Bga, Polyethylene Exp-Cabinet	1	21	131 2 1310 22101	Nameplate-Lid Top, Lid Inside	2
	131 6 3009 19520	Pad-Turntable	1	22	131 2 2108 00900	Hige-Lid	2
	131 6 3009 19660	Pad-Right, Left	2	23	101 3 1204 00803	Screw, Flat HD 4 x 8	4
	131 6 2719 10600	Bag, Fan	1	24	131 2 2904 11900	Pad Lid-Lid	2
	131 6 4119 45304	Explanatory Booklet	1	17	131 2 2611 14700	Pad Lid-Lid	1
	131 6 4159 14700	Notes	1	25	4 2359 21220	Power Select Soker	1
<b>CABINET</b>				26	4 2369 20550	Power Select Soker	1
1	131 2 1101 30201	Cabinet	1	27	104 3 1103 00002	Nut 3mm	2
2	131 2 4212 00101	Nut Plate	2	28	105 3 1203 00002	Spring Washer 3φ	2
3	106 3 1102 71001	Screw, Round HD WD +2.7 x 10	4	29	4 2379 20930	Terminal	1
4	131 2 3608 10200	Cramp Wire	1	30	4 2519 21180	Power Trans	1
5	106 3 1103 10801	Screw, Round HD WD + 3.1 x 8	1	32	131 2 3101 23400	Metal mount	1
6	131 2 3101 14400	Badge	1	33	131 2 4203 83200	Washer 3 x 8 x 0.5t	1
7	131 2 1804 10401	Leg	4	34	105 3 1203 00002	Spring Washer 3φ	1
9	106 3 1103 11301	Screw, Round HD WD + 3.1 x 13	4	35	104 3 1103 00002	Nut 3mm	1
10	131 0 2002 14201	Hinge Assy-Cabinet	2	36	101 3 1103 00802	Screw Phn 3 x 8	2
11	106 3 1103 11302	Screw, Round HD WD + 3.1 x 13	6	37	101 3 1103 01602	Screw Phn 3 x 16	2
	131 2 1310 22801	Nameplate-Cabinet Rear	1	38	131 0 4006 00300	Cord Assy	1
14	131 2 3608 11000	Cramp Wire Phono Cord	1	39	105 3 1203 83200	Spring Washer 3φ	2
15	106 3 1103 10801	Screw, Round HD WD + 3.1 x 13	1	40	131 2 4203 83200	Washer 3 x 8 x 0.5t	2
16	131 2 6111 10300	Bushing-Wire Shield Assy	1	41	104 3 1103 00002	Nut 3mm	2
17	131 2 6111 14200	Bushing-AC Power Cord	1	42	131 0 4004 12006	Wire Shield Assy	1
				43	131 0 4004 12007	Wire Shield Assy	1
				44	292 3 0015 00157	Earth Lead	1
				45	101 3 1103 01602	Screw Pan Hd 3 x 16z	2

# CABINET EXPLODED VIEW (TP625 MV)

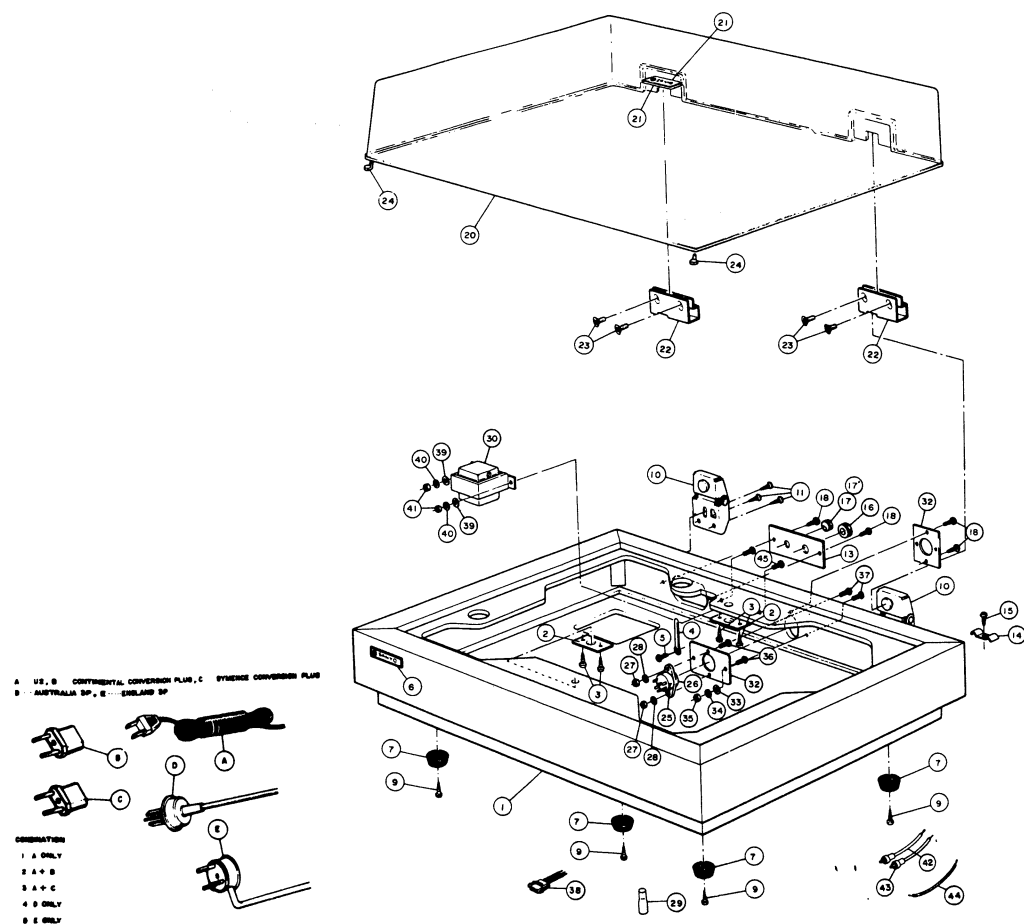

**PARTS LIST (TP625 SEV)**

Key No.	Part No.	Description	Q'ty
<b>PACKING</b>			
	131 6 1139 51714	Box, Corrugate Exp	1
	131 6 2119 01330	Bag, Polyethylene Exp-Lid	1
	131 6 2119 01361	Bag, Polyethylene Exp-Cabinet	1
	131 6 3009 19520	Pad-Turntable	1
	131 6 3009 19660	Pad-Right, Left	2
	131 6 2719 10600	Bag, Fan	1
	131 6 4119 45300	Explanatory Booklet	1
<b>CABINET</b>			
1	131 2 1101 30200	Cabinet	1
2	131 2 4212 00101	Nut Plate	2
3	106 3 1102 71001	Screw, Round HD WD + 2.7 x 10	4
4	131 2 3608 10200	Cramp Wire	1
5	106 3 1103 10801	Screw, Round HD WD + 3.1 x 8	1
6	131 2 3101 14400	Badge	1

Key No.	Part No.	Description	Q'ty
<b>CABINET</b>			
7	131 2 1804 10401	Leg	4
9	106 3 1103 11301	Screw, Round HD WD + 3.1 x 13	4
10	131 0 2002 14201	Hinge Assy-Cabinet	2
11	106 3 1103 11302	Screw, Round HD WD + 3.1 x 13	6
12	131 2 1310 22801	Nameplate-Cabinet Rear	1
13	131 2 3101 11901	Metal Mount	1
14	131 2 3608 11000	Cramp Wire-wire Shield Assy	1
15	106 3 1102 72001	Screw, Round HD WD + 2.7 x 20	1
16	131 2 6111 10300	Bushing Wire Shield Assy	1
17	131 2 6111 14200	Bushing-AC Power Cord	1
18	106 3 1103 11301	Screw, Round HD WD + 3.1 x 13	1
20	131 2 1107 18900	Lid	1
21	131 2 1310 22101	Nameplate-Lid Top, Lid Inside	2
22	131 2 2108 00900	Hinge-Lid	2
23	101 3 1204 00803	Screw, Flat HD 4 x 8	4
24	131 2 2904 11900	Pad Lid-Lid	2

**CABINET EXPLODED VIEW (TP625 SEV)**

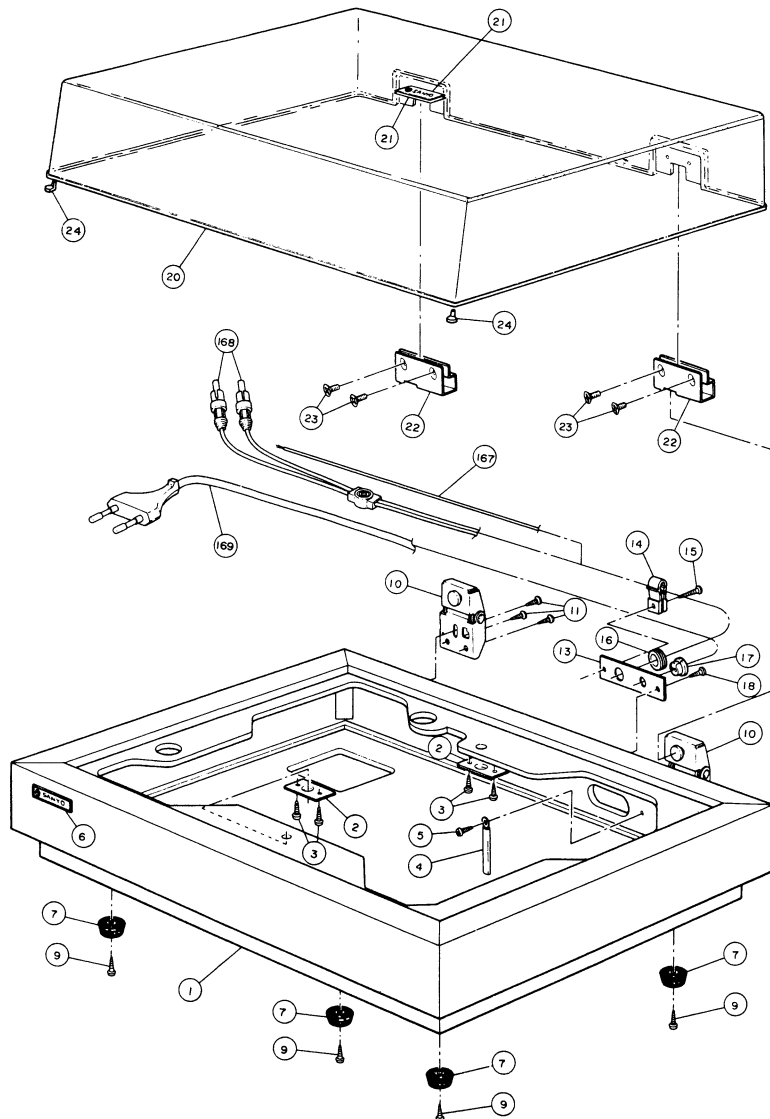

**PARTS LIST (TP625 UK)**

Key No.	Part No.	Description	Q'ty	Key No.	Part No.	Description	Q'ty
<b>PACKING</b>				<b>CABINET</b>			
	131 6 1139 51714	Box, Corrugare Exp	1	5	106 3 1103 10801	Screw Round HD WD + 3.1 x 8	1
	131 6 2119 01330	Bag, Polythylene Exp-Lid	1	6	131 2 3101 14400	Badge	1
	131 6 2119 01361	Bag, Polythylene Exp-Cabinet	1	7	131 2 1804 10401	Leg	4
	131 6 3009 19520	Pad-turntable	1	9	106 3 1103 11301	Screw Round HD WD + 3.1 x 13	4
	131 6 3009 19660	Pad-Right Left	2	10	131 0 2002 14201	Hinge-Assy Cabinet	2
	131 6 2719 10600	Bag, Fan	1	11	106 3 1103 11302	Screw Round HD WD + 3.1 x 13	6
	131 6 4119 45302	Explanatory Booklet	1		131 2 1310 23401	Name Plate-Cabinet Rear	1
	131 6 3069 15800	Wadding Paper	1	13	131 2 3101 11901	Metal Mount	1
	131 6 4159 22900	Notes	1	14	131 2 3608 10301	Cramp Wire	1
	131 6 4159 22901	Notes	1	14'	131 2 3608 10300	Cramp Wire	1
	131 6 4519 13700	Gurantee Card	1	15	106 3 1103 11301	Screw Round HD WD 3.1 x 13	1
				16	131 2 6111 10300	Bushing-Wire Shield Assy	1
				17	131 2 6111 14700	Bushing-AC Power Cord	1
				18	106 3 1103 11301	Screw Round HD WD + 3.1 x 13	4
				20	131 2 1107 18900	Lid	1
1	131 2 1101 30202	Cabinet	1	21	131 2 1310 22101	Name plate-Lid, Top Inside	2
2	131 2 4212 00101	Nut Plate	2	22	131 2 2108 00900	Hinge-Lid	2
3	106 3 1102 71001	Screw Round HD WD + 2.7 x 10	4	23	101 3 1204 00803	Screw, Flat HD 4 x 8	4
4	131 2 3608 10200	Cramp Wire	1	24	131 2 2904 11900	Pad Lid-Lid	2

**CABINET EXPLODED VIEW (TP625 UK)**

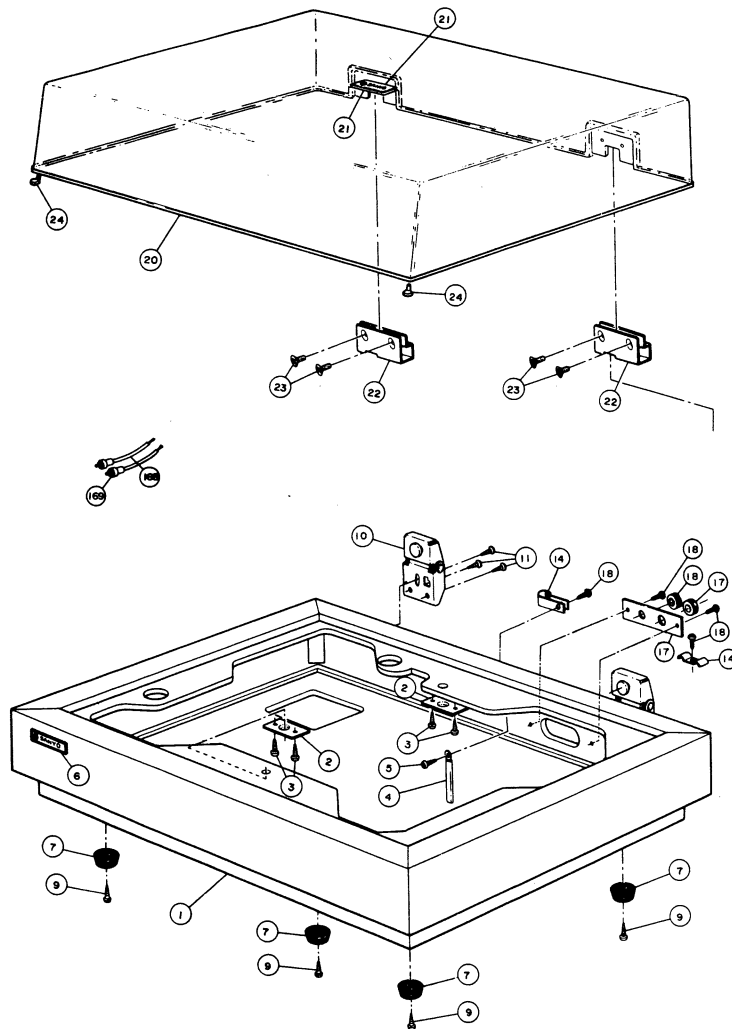

# TURNTABLE EXPLODED VIEW (MV, UK)

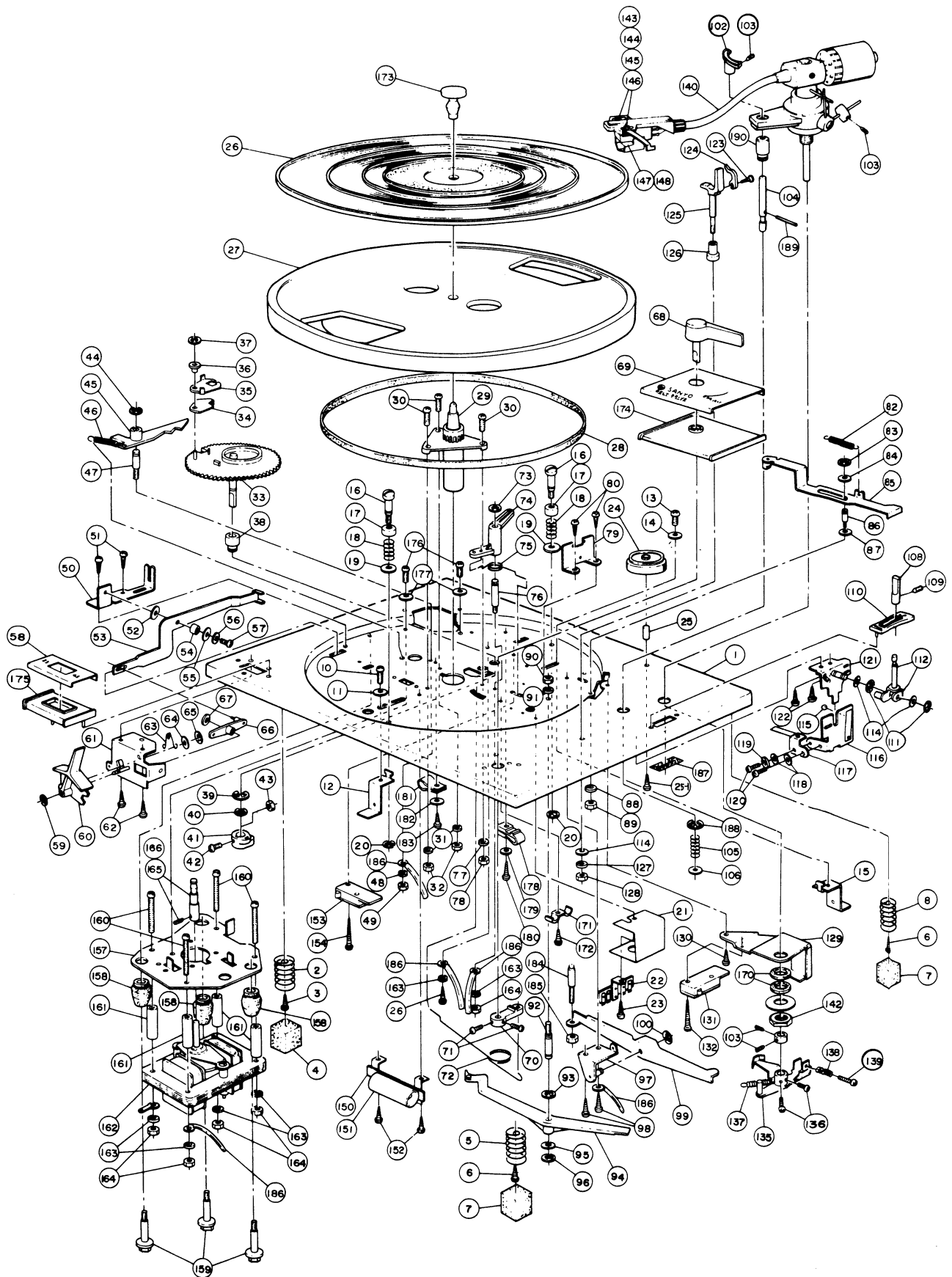

**PARTS LIST**

Key No.	Part No.	Description	Q'ty	Key No.	Part No.	Description	Q'ty
1	134 0 6001 12110	Unit Plate Assy (MV, UK)	1	72	134 2 5101 20100	Spring	1
1	134 0 6001 12140	Unit Plate Assy (SEV)	1	73		E Ring 3mm	1
2	134 2 5102 12300	Spring,Mounting-Left Front, Rear	2	74	134 2 4120 14600	Lever	1
3		Screw, Pan Hd. Tapping 3.5 x 8	2	75	134 2 5101 20200	Spring	1
4	134 2 5205 10000	Cushion (MV, UK)	2	76	134 2 4106 15000	Shaft	1
4	134 2 5205 10002	Cushion (SEV)	2	77		Washer, 3mm (SEV only)	1
5	134 2 5102 12500	Spring Mounting-Right Front	1	78		Nut 3mm (SEV only)	1
6		Screw, Pan Hd. Tapping 3.5 x 8	2	79	134 2 4121 10600	Guide	1
7	134 2 5105 10002	Cushion	2	80		Screw, Pan Hd. Tapping 3 x 6	2
8	134 2 5102 12400	Spring Mounting-Right Rear	1	81	134 0 6035 10800	Arm Return Assy	1
10		Screw, Pan Hd. 4 x 8	1	82	134 2 5101 20800	Spring	1
11		Washer, Polyethylene 4 x 10 x 0.8t	1	83		E Ring 3mm	1
12	134 2 2403 12300	Angle Mount-Front	1	84		Washer, 3 x 8 x 1t	1
13		Screw, Pan Hd. 4 x 8	1	85	134 0 6035 10800	Arm Return Assy	1
14		Washer, 4.5 x 10 x 0.8t	1	86	134 2 4106 15700	Shaft	1
15	134 2 2403 12300	Angle Mount-Rear	1	87		Washer, 4.5 x 12 x 0.8t	1
16	134 2 2104 10800	Screw Transit	2	88		Washer, 3	1
17	134 2 4213 10300	Washer Bowl	2	89		Nut 3mm	1
18	134 2 5101 20000	Spring	2	90		Nut 3mm	1
19		Washer, 6 x 14 x 1t	2	91		Washer, 3	1
20		E Ring 4mm	2	92	134 2 4106 15500	Shaft	1
21	131 2 6103 12300	Cover Shield	1	93		E Ring 3mm	1
22	4 2379 20400	Lug 4P	1	94	134 2 4123 12900	Arm	1
23		Screw, Pan Hd. Tapping 3 x 6	1	95		Washer, 5 x 10 x 0.3t	1
24	134 2 2901 10500	Adapter EP-For 45rpm	1	96		E Ring 3mm	1
25	134 2 2902 00302	Pin Adapter EP	1	97	134 0 6026 10500	Angle elevate Assy	1
25-1		Screw, Pan Hd. Tapping 3 x 6	1	98		Screw, Pan Hd. Tapping 3 x 6	2
26	134 2 6102 12701	Mat Turntable (MV, UK)	1	99	134 0 6009 12500	Lever Set Assy	1
26	134 2 6102 13101	Mat Turntable (SEV)	1	100		E Ring 3mm	1
27	134 2 6101 11001	Turntable	1	101	134 2 5205 10600	Cushion	1
28	134 2 6302 10200	Belt	1	102	134 2 3310 10500	Support Arm	1
29	134 0 5002 10200	Spindle Turntable Assy	1	103		Screw, 2.6 x 3	1
30		Screw, Pan Hd. 3 x 8	3	104	134 2 4116 11500	Spindle Lifting	1
31		Washer, 3	3	105	134 2 5101 21400	Spring	1
32		Nut 3mm	3	106		Washer, 4.5 x 10 x 0.8t	1
33	134 2 4110 10900	Gearcycling	1	107		E Ring 3mm	1
34	134 2 4122 11300	Trip	1	108	131 2 1601 30501	Knob	1
35	134 2 4122 10800	Trip	1	109		Screw, 2.6 x 3	1
36	134 2 4107 12600	Collar	1	110	134 2 1405 00700	Cover Select	1
37		CS Ring 3mm	1	111		E Ring 3mm	1
38	134 2 4118 13500	Boss	1	112	134 0 6009 12200	Lever Set Assy	1
39		E Ring 8mm	1			E Ring 3mm	1
40		E Ring 4mm	1	114		Washer, 4.5 x 10 x 0.8t	1
41	134 2 4118 13600	Boss	1	115		Steel Ball 4mm	1
42		Screw, Pan Hd. 3 x 5	1	116	134 0 6026 10800	Angle Elevate Assy	1
43		Nut 3mm	1	117	134 0 6026 11000	Angle Elevate Assy	1
44		E Ring 3mm	1	118		Washer, 3 x 8 x 0.5t	1
45	134 2 4120 14700	Lever	1	119		Washer, 3mm	2
46	134 2 5101 20400	Spring	1	120		Screw, Pan Hd. 3 x 5 (SEV only)	2
47	134 2 4106 15400	Shaft	1	121	134 0 6026 10900	Angle Elevate Assy	1
48		Waher, 3	1	122		Screw, Pan Hd. Tapping 3 x 6	2
49		Nut 3mm	1	123		Screw, Pan Hd. 2.6 x 5	1
50	134 2 2403 13900	Angle Mount	1	124	134 2 3308 10500	Holder Pickup	1
51		Screw, Pan Hd. Tapping 3 x 6	2	125	134 2 3301 12000	Armrest	1
52		Washer, 3 x 8 x 0.5t	1	126	134 2 4107 12800	Collar	1
53	134 2 3301 12000	Arm	1	127		Washer, 3mm	1
54	134 2 4107 00200	Collar (MV UK)	1	128		Nut 3mm	1
54	134 2 4107 12800	Collar (SEV)	1	129	134 2 4108 1300	Plate	1
55		Washer, 3 x 12 x 1t	1	130		Screw, Pan Hd. Tapping 3 x 6	1
56		Washer 3	1	131	4 2319 21990	Switch Power	1
57		Screw, Pan Hd. 3 x 8	1	132		Screw, Pan Hd. Tapping 3 x 14	1
58	134 0 1007 00200	Cover Select Assy	1		131 2 1401 10300	Cover	1
59		E Ring 3mm	1	134		Screw, Pan Hd. Tapping 3 x 16	1
60	134 2 1601 12600	Knob	1	135	134 0 6022 10400	Plate Pickup fix Assy	1
61	134 0 6009 10801	Lever Set Assy	1	136		Screw, Pan Hd. 4 x 8	2
62		Screw, Pan Hd. 3 x 5	2	137	134 2 5101 20500	Spring	1
63	134 2 5101 20300	Spring	1	138	134 2 5101 20600	Spring	1
64		Washer, 3 x 8 x 0.5t	1	139		Screw, Pan Hd. 3 x 12	1
65		E Ring 3mm	1	140	4 1579 20800	Pickup	1
66	134 2 4127 10100	Seasaw	1	141		Washer	1
67		E Ring 3mm	1	142	134 2 4208 11501	Nut	1
68	134 0 1004 12100	Knob Rejector Assy	1	143	134 2 4201 11305	Screw	2
69	134 0 1005 10380	Cover Rejector Assy	1	144	134 2 4203 01800	Washer	2
70	134 2 4120 14500	Lever	1	145	4 1579 26710	Cartridge, MG-28	1
71		Screw, Pan Hd. 3 x 8	2	146	4 1579 29230	Pickup Stylus, ST-28D	1
				147	134 2 1402 11500	Retainer Needle	1
				148	134 2 4208 11300	Nut	2

## PARTS LIST

Key No.	Part No.	Description	Q'ty
150	4 2379 20422	Lug 4P	1
151		Capacitor 0.047 $\mu$ F/630WV	1
152		Screw, Pan Hd. Tapping 3 x 6	2
153	4 2319 21990	Switch Power	1
154		Screw, Pan Hd. Tapping 3 x 14	1
	131 2 1401 10300	Cover	1
		Screw, Pan Hd. Tapping 3 x 16	1
157	134 2 4108 15600	Plate	1
158	134 2 5202 10800	Rubber Cushion	3
159	134 2 4106 19500	Shaft	3
160		Screw, Pan Hd. 3 x 35	4
161	134 2 4206 12600	Spacer	4
162	4 5289 20402	Synchro Motor (MV)	1
162	4 5289 20301	Synchro Motor (SEV)	1
162	4 5289 20203	Synchro Motor (UK)	1
163		Washer, 3mm	4
164		Nut 3mm	4
165	134 2 6401 11502	Pully 50Hz (MV)	1
165	134 2 6401 11503	Pully 60Hz (MV)	1
165	134 2 6401 11600	Pully (SEV)	1
165	134 2 6401 11502	Pully (UK)	1
166		Screw	1
167		Wire, 1.5 Meter, #22 1007	1
168	131 0 4004 11700	Wire Shield Assy (SEV only)	1
168	131 0 4004 12006	Wire Shield Assy (UK only)	1
169	4 2439 20523	Power Cord (SEV only)	1
	4 2439 20500	Power Cord (SEV only)	1
169	131 0 4004 12007	Wire Sheild Assy (UK only)	1
	4 2439 20481	Power cord (MV only)	1
	4 2439 20394	Power cord, 2P (MV only)	1
171	131 2 3608 10300	Cranmp Wire	1
172		Screw Pan HD 3 x 8	1
173	131 2 2903 12360	Rubber Pad	1
174	134 2 1210 10608	Plate Ind rejector	1
175	134 2 1405 00100	Cover Select	1
176		Screw PAN HD M4 x 2	2
177		Fiber Washer 4 x 10 x 0.5t	2
178	131 2 3608 12400	Cranmp Wire	1
179		Washer 3 x 8 x 0.5t	5
180		Screw PAN HD Tapping 3 x 12	1
181	131 2 3608 11000	Cranmp Wire	1
182		Washer 3 x 8 x 0.5t	1
183		Screw PAN HD Tapping 3 x 8	1
184	134 2 4106 15900	Sahft	1
185		Nut M3	12
186	131 2 3608 10200	Cranmp Wire	5
187	4 2317 20180	Fuse 0.5A (MV, WK only)	1
187	131 2 6113 16100	Shelter (SEV only)	1
188		E ring 3 $\phi$	11
189		Spring 2 x 16	1
190	134 2 4118 14700	Bose (SEV only)	1
191	4 2359 21020	Fuse Holder (SEV only)	1
192	4 2349 20380	Fuse 1.0AT (SEV only)	1
193	4 2319 21530	Switch Slide 6p (SEV only)	1
194	131 2 7104 00101	Plate Pad Switch (SEV only)	1
195		Screw Pan HD 2.5 (2.6) x 6 (SEV only)	1



# TURNTABLE EXPLODED VIEW (TP625 SEV)

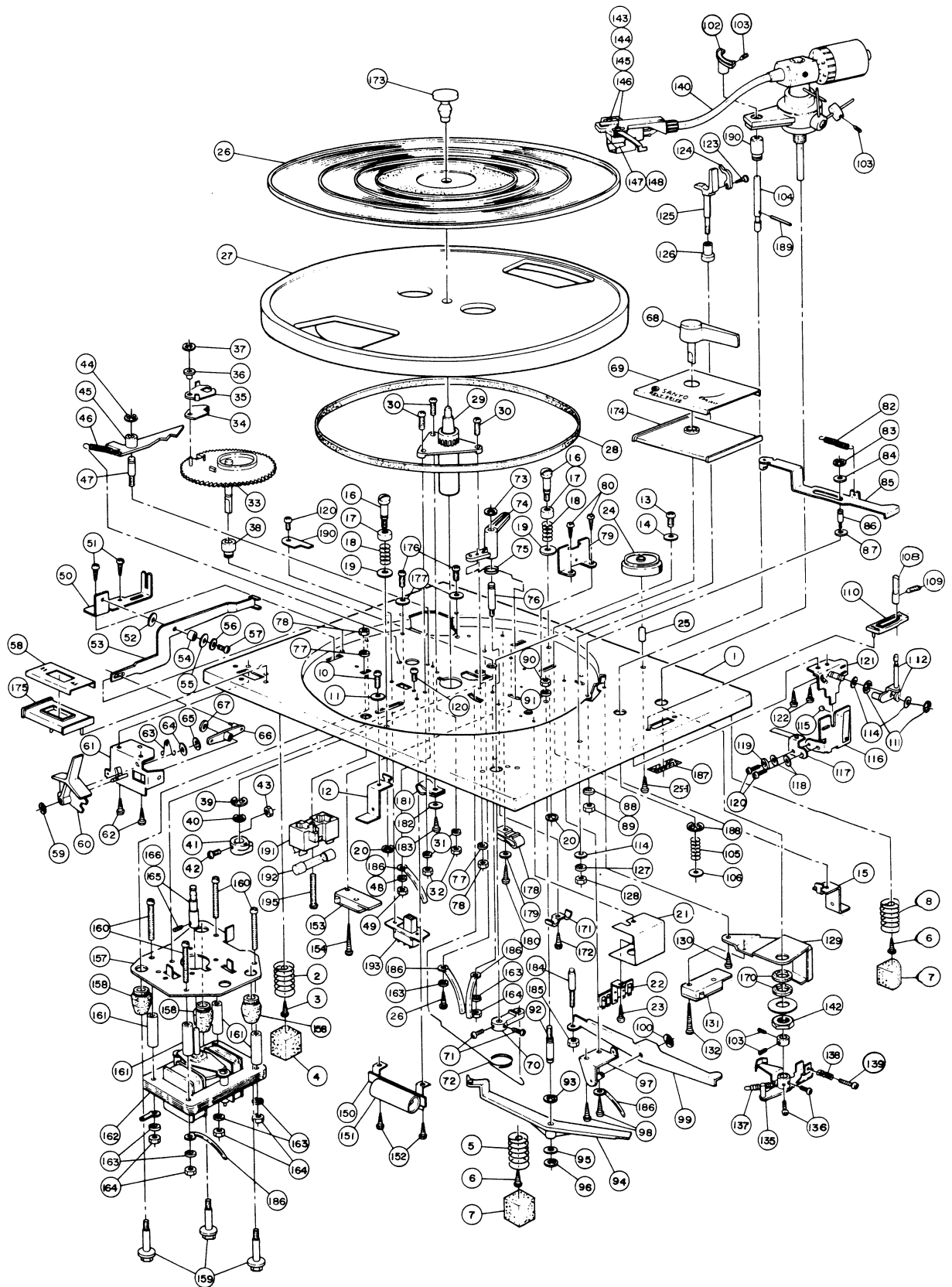

**SCHEMATIC DIAGRAM (TP625 MV)**

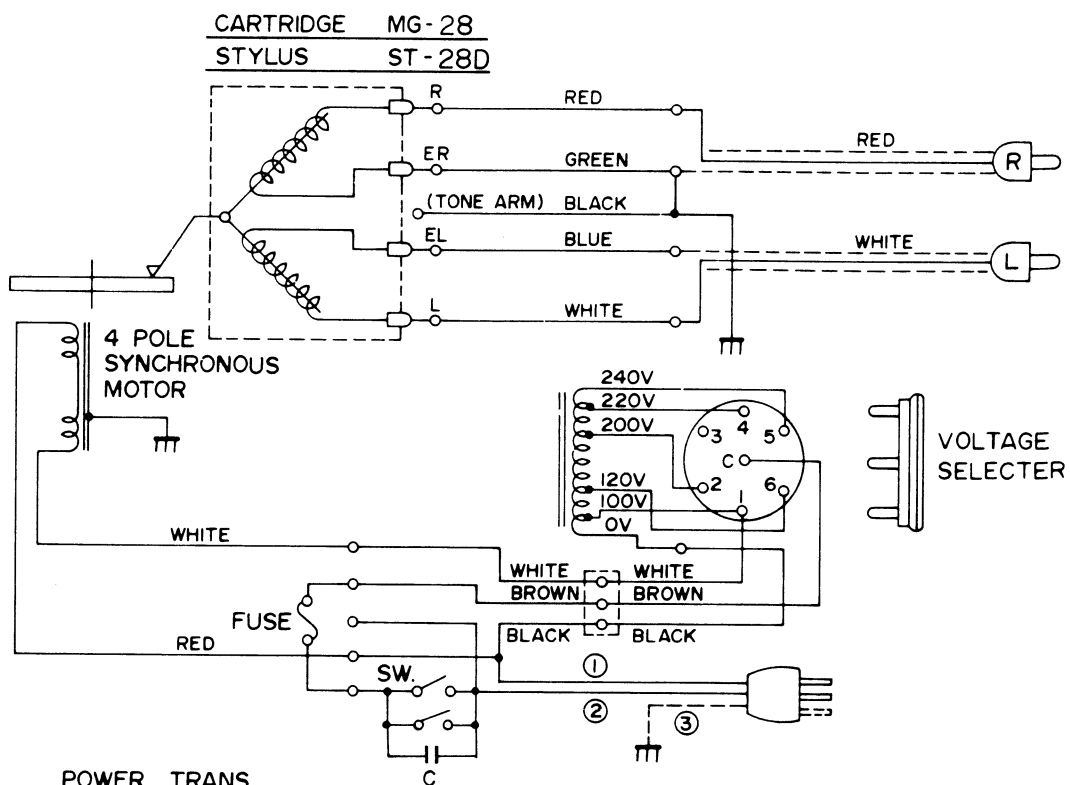

**POWER TRANS**

VOLTAGE	COLOR
240V	RED
220V	ORANGE
200V	BROWN
120V	WHITE
100V	BLUE
0V	BLACK

**WHEN USING E3 CORD**

	①	②	③
ENGLAND	BLUE	BROWN	YLW-GRN

**SCHEMATIC DIAGRAM (SEV)**

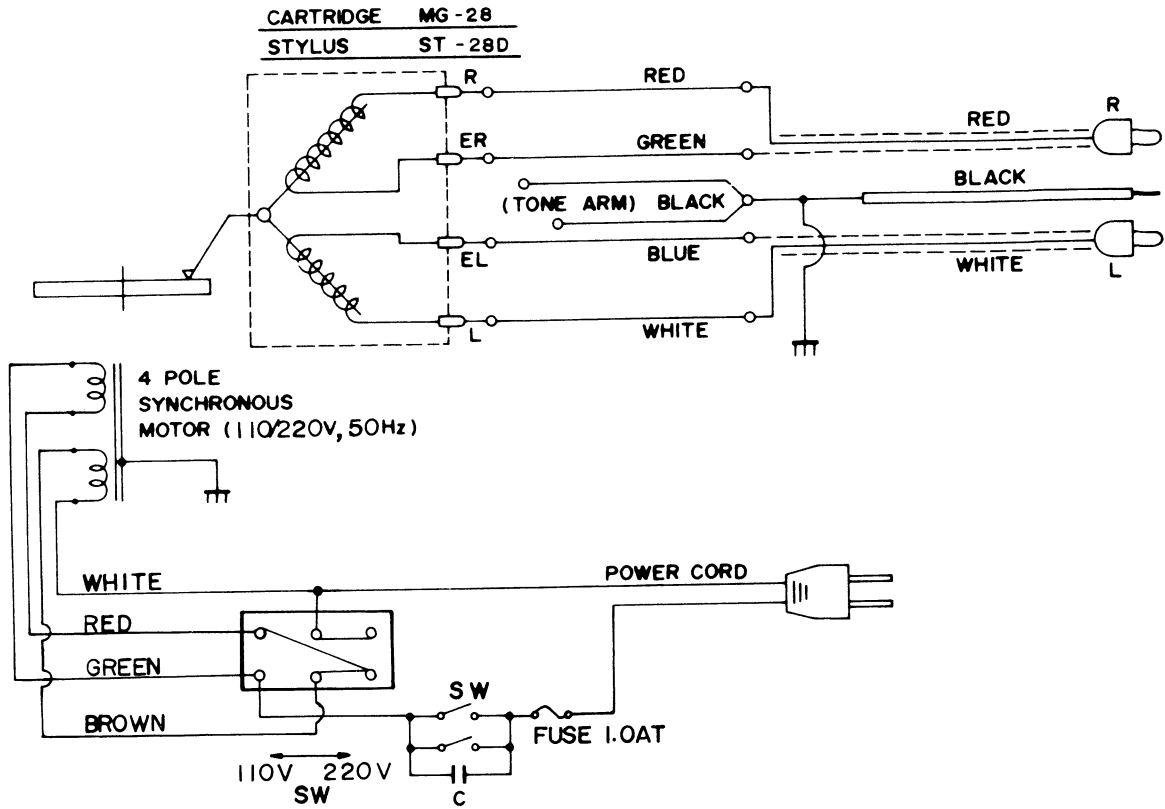

**SCHEMATIC DIAGRAM (UK)**

