

MKH 20



MKH 30



MKH 40



MKH 50



MKH 60



MKH 70

Subject to alterations

MKH 20...70

Safety requirements



Observe safety regulations.

Observe ESD instructions while handling electrostatically endangered components.



Only skilled persons are allowed to alter and repair. For repairs and exchanges only approved components according to the current spare parts list are allowed.

It is forbidden to alter the product unauthorized.

If not observed the adaptor is legally liable for possible results of damage.

repairs/exchanges

The following instructions for overhaul and testing must be followed. In case of unusual problems please contact your Sennheiser distributor.

Contents

| | |
|---------------------------------|-----------|
| MKH 20...70 | 2 |
| Safety requirements | 2 |
| Description | 5 |
| Test instructions..... | 9 |
| MKH 20 P 48 | 11 |
| Brief description | 11 |
| Features | 11 |
| Controls..... | 12 |
| Technical data | 12 |
| Exploded view..... | 14 |
| Schematic representations | 15 |
| MKH 20, solder side..... | 15 |
| MKH 20, component side | 15 |
| MKH 20, circuit diagram | 16 |
| MKH 30 P 48 | 17 |
| Brief description | 17 |
| Features | 17 |
| Controls..... | 18 |
| Technical Data..... | 18 |
| Exploded view | 20 |
| Schematic representations | 21 |
| MKH 30, solder side..... | 21 |
| MKH 30, component side | 21 |
| MKH 30, circuit diagram | 22 |
| MKH 40 P 48 | 23 |
| Brief description | 23 |
| Features | 23 |
| Controls..... | 24 |
| Technical Data..... | 24 |
| Exploded view | 26 |
| Schematic representations | 27 |
| MKH 40, solder side..... | 27 |
| MKH 40, component side | 27 |
| MKH 40, circuit diagram | 28 |

Contents

| | |
|------------------------------------|-----------|
| MKH 50 P 48 | 29 |
| Brief description..... | 29 |
| Features..... | 29 |
| Controls | 30 |
| Technical Data | 30 |
| Exploded view..... | 32 |
| Schematic representations | 33 |
| MKH 50, solder side..... | 33 |
| MKH 50, component side | 33 |
| MKH 50, circuit diagram | 34 |
| MKH 60-1 P 48..... | 35 |
| Brief description..... | 35 |
| Features..... | 35 |
| Controls | 36 |
| Technical Data | 36 |
| Exploded view..... | 38 |
| Schematic representations | 40 |
| MKH 60, solder side..... | 40 |
| MKH 60, component side | 40 |
| MKH 60, circuit diagram | 41 |
| MKH 60, component side, new..... | 42 |
| MKH 60, solder side, new | 42 |
| MKH 60, circuit diagram, new | 43 |
| MKH 70-1 P 48..... | 45 |
| Brief description..... | 45 |
| Features..... | 45 |
| Controls | 46 |
| Technical Data | 46 |
| Exploded view..... | 48 |
| Schematic representations | 50 |
| MKH 70, solder side..... | 50 |
| MKH 70, component side | 50 |
| MKH 70, circuit diagram | 51 |
| MKH 70, component side, new..... | 52 |
| MKH 70, solder side, new | 52 |
| MKH 70, circuit diagram, new | 53 |

Description

Contents of these Service Instructions

These Service Instructions summarize the technical documentation on the microphones MKH 20 to MKH 70. Information concerning all models is given first, followed by detailed data on individual microphones.

Service concept

Tests and checks for faults are divided into 3 parts:

1. Acoustic test
2. Capsule check
3. Test instructions

General service information

In the event of a service incident, perform a general functional check, first. For this purpose, connect the microphone to an amplifier under field conditions and monitor the microphone using headphones. Speak into the microphone, shake the microphone, and move the connection cable.

In most cases, this acoustic test will give you a first impression of the kind of fault that occurred. Perform all subsequent testing and measuring measures according to the following test instructions.

Checking the microphone capsule

To check the microphone capsule, disassemble the microphone, first.

For the MKH 60 and the MKH 70, unscrew the sound inlet, first.

Loosen the two countersunk head screws on the housing and then use the XLR connector pins to carefully press out the frame together with the capsule. To further disassemble the microphone, loosen the three screws on the capsule and then pull off the capsule.

Before you touch the connections 1 and 3, touch the capsule housing to avoid damage due to electrostatic discharge. When connecting measuring equipment, always establish the connection to the capsule housing (pin 2) first.

Attention!



Checking the capacitance

Capsule connections (bottom view):

Use a capacitance meter to measure the capsule capacitance.

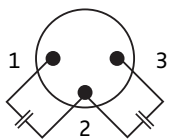

Type 1; KS 20, 30, 40, 50
Type 2; KS 60, 70

Capacitance: 40 to 45pF
Capacitance: 30 to 35pF

Checking the insulation

Capsule connections (bottom view):

Use a multimeter (20M Ω range) to measure the capsule resistance.

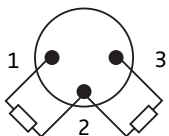

R > 20M Ω (out of range)

Circuit description MKH20...70

RF bridge circuit (capsule bridge)

In connection with the windings 1-2 and 3-4 of the RF coil L1 the push-pull capsule forms a bridge circuit. Each displacement of the diaphragm by a sound signal changes the two capsule capacitances in the respective opposite direction, resulting in a proportional RF voltage at the bridge output 2/3. L3 compensates the reactive component of the bridge output impedance, so that the bridge output becomes a real and low-resistance output.

Using the coil core of L1 the bridge is balanced by changing the winding inductances in the respective opposite directions, so that the bridge output voltage becomes zero when the diaphragm is in its neutral position. This is the case when the direct voltage between the measuring points A and B becomes zero (balance).

The bridge output signal is transformed by the RF coil L2 and decoupled from ground. Its primary winding 13-14 is roughly tuned to the oscillator frequency by C1. A fine-tuning with the core of L2 is not required, since the circuit is highly attenuated by the low bridge impedance. For optimum coupling, the core should be positioned in the center of the coil.

Together with the tapping 16/17 of the secondary winding 15-18 the switch makes it possible to achieve a signal attenuation of 10dB (pre-attenuation).

The demodulator and oscillator circuits of the microphones MKH20...50 and MKH60...70 only differ with regard to different component references. In the following sections, data that exclusively apply to the MKH60...70 are put in parentheses.

Demodulator

Via L2 the RF bridge signal is supplied to the demodulator with D1, D2, and C5, C6 (or C3, C5) and the symmetrical windings 5-6 and 7-8 of L1. The demodulator operates as a synchronous rectifier putting through the RF signal of L2 to C6 (or C5) during one half-wave, while blocking it during the other half-wave. The rectified voltage at C5 (or C3) biases both D1 and D2 to such an extent that they will securely block even signals with a higher intensity. The rectified voltage is stabilized with D3, D4 (or R6, R9).

When zero balancing is correct, the direct voltage between the measuring points A and B reaches zero, and half the rectified voltage is supplied to C6 (or C5).

Depending on the direction of diaphragm displacement the bridge output voltage is either in phase or opposite in phase to the voltages at the diode windings 5-8.

The synchronous rectification results in an increase or decrease of the voltage at C6 (or C5) corresponding to the diaphragm movement.

Oscillator

The frequency of the RF oscillator results from the capsule capacitances and the inductances of the L1 windings 1-2 and 3-4 and ranges from about 6.5 to 7.5MHz. The collector winding 9-10 and the feedback winding 11-12 couple the oscillator transistor T1 (or Q1) to the capsule circuit. R1 prevents generation of parasitic oscillations in the VHF range. C2, C3, C4 (or C2, C4, C10) are used for RF blocking, L4 (or L5) acts as an RF choke.

The operating current of the microphone flows through the oscillator and is stabilized to 2mA by T2 (or Q2), R3, R4, and R5 (constant-current circuit). The NTC resistor R5 stabilizes against temperature influences. R2 ensures a sufficiently high collector voltage of T2 (or Q2), since the base-emitter voltage of T1 (or Q1) is negative (Class C mode).

AF amplifier MKH20...50

Since the AF circuits of the microphones MKH20...50 and MKH60...70 differ considerably, they are described separately in the following sections.

The amplifier in the MKH20...50 operates with the complementary transistors T3 (or Q3) and T4 (or Q4) in push-pull Class A mode. On the DC side, the transistors are connected in series, on the AC side they are connected in parallel via C12 and C14. This increases the available AC output current, enhances the linearity, and reduces the background noise. The base voltage divider R17, R18, R19, D5 determines the operating voltage of the amplifier and stabilizes it against temperature influences. The AF signal of the demodulator is supplied to the amplifier input via the high pass C19, R16, and C11. The amplifier output is connected to the microphone output via C15, C16, R22, R23, and the RF barrier L6, L7, and C17 to C20. The output impedance is mainly determined by R22, R23, and the resistive portions of L6 and L7, and is about 150Ω. The Z diodes D6 to D8 protect C14 to C16 from overvoltages. For each microphone type, the frequency response of the capsule is equalized by frequency-dependent negative-feedback circuits described for the individual types in the following sections.

Equalization for MKH20

The series resonance circuit L5, C7, R7 in connection with R9 and R14 causes a treble emphasis with a maximum at 20kHz. In the S2 standard position, R9 is short-circuited and only R14 is effective. If S2 is opened (diffuse-field correction), R9 is in series with R14 and causes a higher treble emphasis. R13 and C8 correct the frequency response in the center frequency range.

Equalization for MKH30...50

The series resonance circuit L5, C7, R7 in connection with R9 causes a treble emphasis with a maximum at 20kHz. In addition, C9, R11, and R12 cause a bass emphasis. In the S2 standard position, R11 and R12 are connected in parallel. If S2 is opened (bass roll-off), only R12 is effective and the bass emphasis is reduced. R13 and C8 correct the frequency response in the center frequency range.

AF amplifier MKH60...70

The amplifier integrated in both the MKH60 and the MKH70 is a two-stage amplifier. The pre-amplifier with T3 (or Q3) equalizes the capsule frequency response. The output stage operates as a high-pass filter at low frequencies. The AF output signal of the demodulator is supplied to the base of T3 (or Q3) via the high-pass of C6, C7 in connection with the base voltage divider R10, R11. S2 can be used to switch the operating frequency of the bass roll-off. Frequency response equalization for high frequencies is realized by the negative-feedback network R9, R12, R13, C8, and L4. S3 can be used to switch the operating frequency of the treble emphasis, so that the result is either a neutral frequency response or a frequency response with treble emphasis. The collector resistance of T3 (or Q3) results from the dynamic internal resistance of the oscillator circuit and is very high in the AF range due to the current stabilization. The output signal of the pre-amplifier is supplied to the output stage via C12 and C13. The output stage operates as an active high-pass with voltage amplification 1. The quality is determined by a positive feedback via R14 in interaction with R15 and R17. T4 (or Q4) and T5 (or Q5) operate in complementary push-pull Class A mode. On the DC side, they are connected in series, on the AC side, they are connected in parallel via C14 and C16. This increases the available AC output current, enhances the linearity, and reduces the background noise. The base voltage divider R15, R16, R17, D3 determines the operating voltage and stabilizes it against temperature influences.

The amplifier output signal is supplied to the microphone output via C17, C18, R20, R21, and the RF barrier L6, L7, and C19 to C22. The output impedance is mainly determined by R20, R21, and the resistive portions of L6 and L7, and is about 150Ω in the center frequency range. The Z diodes D4 to D6 protect C16 to C18 from overvoltages.

Output circuit

During phantom supply, each of the two cable strands supplies half of the operating current to the microphone. The divided operating current is merged by the two resistors R20 and R21 (or R18, R19) with identical resistances. The current flows back to the phantom supply source via the amplifier circuit (MKH60...70: via both amplifier stages), the oscillator, and the cable shield (microphone ground). Since the operating current is stabilized by the oscillator circuit, the AC side of the amplifier circuit is decoupled from ground ("electronic choke") and the available output signal is floating. The signal is balanced by means of the two supply resistors (6.8kΩ each) of the phantom supply source.

Test instructions

Measuring and test equipment

- 1 AF generator, output voltage 1V
- 1 AF voltmeter, 10mV range
- 1 oscilloscope
- 1 handheld multimeter, range 2V_{DC}
- 1 capacitance meter, 0 to 100pF
- 1 ohmmeter, range 20MΩ
- 1 headphones

Measuring set-up

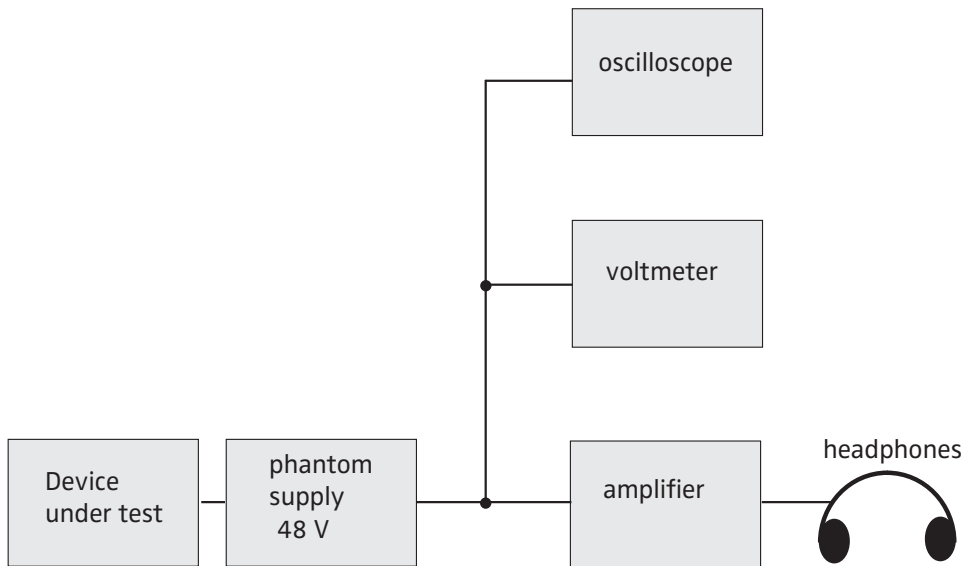

Test procedure

Circuit test MKH20/MKH30/MKH40/MKH50:

- 1** Operating voltage microphone:
Check voltages between R22 or R23 and ground; desired value = +41V;
both voltages have to be identical.
If the no-load voltage of the phantom supply device is not 48V, the deviation from the desired value has to be identical.
- 2** Current consumption microphone:
Check voltages via R20 and R21; desired value in each case = 3.3V
(corresponds to a current of 1mA in each case);
both voltages have to be identical.
- 3** Balancing:
Check the voltage between the measuring points A(+) and B(-);
desired value = 0V
If the value is not 0V, rotate the coil core of L1 until the voltage is 0V.
- 4** Operating voltages output stage:
Check voltage via D6; desired value = 9V
Check voltage via D8; desired value = 8V
- 5** Operating voltage oscillator:
Check voltage via C4; desired value = +28.5V

Circuit test MKH60/MKH70:

- ① Operating voltage microphone:
Check voltages between R20 or R21 and ground; desired value = +41V;
both voltages have to be identical.
If the no-load voltage of the phantom supply device is not 48V, the deviation from the desired value has to be identical.
- ② Current consumption microphone:
Check voltages via R18 and R19; desired value in each case = 2.2V
(corresponds to 1mA in each case);
both voltages have to be identical.
- ③ Balancing:
Check the voltage between the measuring points A(+) and B(-);
desired value = 0V
If the value is not 0V, rotate the coil core of L1 until the voltage is 0V.
- ④ Operating voltage output stage:
Check voltage via D4; desired value = 4.5V
Check voltage via D5; desired value = 4.5V
- ⑤ Operating voltage oscillator:
Check voltage via C10; desired value = +30.5V

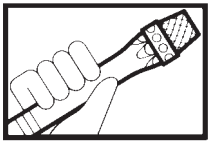

MKH 20 P 48

Brief description

The MKH 20 P 48 is a high-frequency condenser microphone with omnidirectional characteristic.

Features

- Very low noise for highly dynamical recordings
- Distortion-free transmission of sound pressures of up to 142dB
- Transmission range 20 to 20000Hz
- Balanced transformer-free signal decoupling
- Switchable diffuse-field correction for recordings outside of the diffuse-field distance
- Switchable pre-attenuation

Subject to alterations

Controls

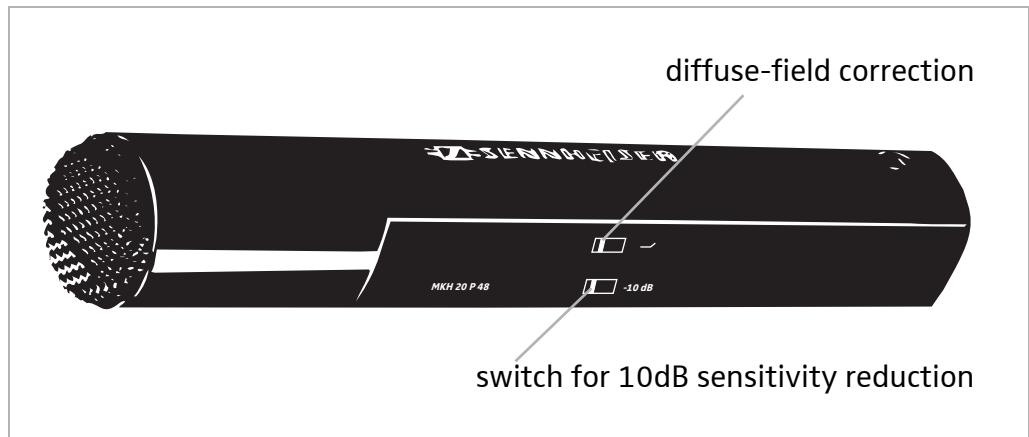

Technical data

Note

The values in parentheses apply to activated pre-attenuation (-10dB)

| | | |
|--|-------|--|
| Acoustic principle | _____ | Pressure receiver |
| Directional characteristic | _____ | omnidirectional |
| Transmission range | _____ | 20 to 20000Hz |
| Free-field no-load transmission factor | | |
| at 1kHz | _____ | 25mV/Pa (8mV/Pa) = -32dBV (-42dBV) |
| Equivalent sound pressure level | | |
| according to DIN 45500, curve A | _____ | 10dB (18dB) |
| according to DIN 45405/CCIR 468 | _____ | 20dB (28dB) |
| Max. sound pressure level | _____ | 134dB (142dB) |
| Output | _____ | balanced, transformer-free |
| Electrical impedance at 1kHz | _____ | 150Ω |
| Min. terminating impedance | _____ | 1000Ω |
| Pre-attenuation | _____ | 10dB, switchable |
| Diffuse-field correction | _____ | switchable |
| Infrasonic attenuation | _____ | 18dB/oct below 20Hz |
| Plug-in connection | _____ | XLR3 |
| Connector layout | _____ | 1: -, housing 2: +, AF+ 3: +, AF- |
| Power supply | _____ | Phantom supply 48V |
| Supply voltage | _____ | 48V ±4V |
| Supply current | _____ | 2mA |
| Dimensions (in mm) | _____ | 25 Ø x 150 |
| Weight | _____ | approx. 100g |
| Scope of delivery | _____ | 1 microphone MKH 20 P 48, 1 floorstand clamp MZQ 40, 1 close-talking and wind protection MZW 41 |

Frequency response

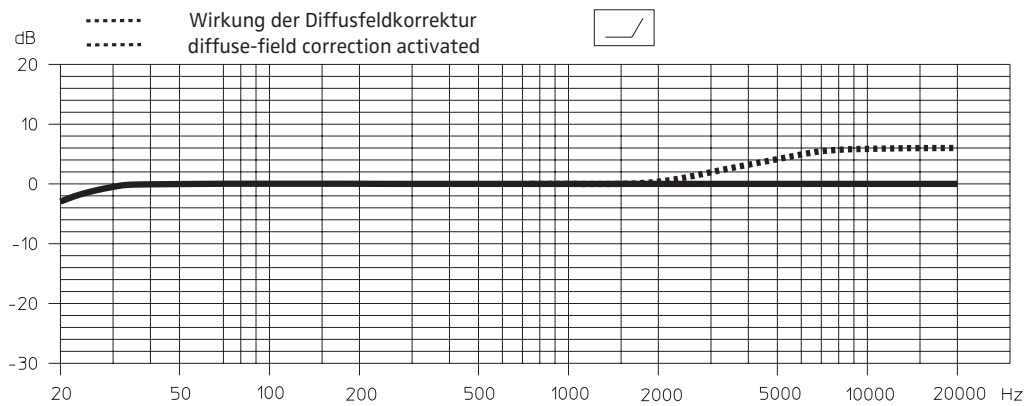

Polar diagram

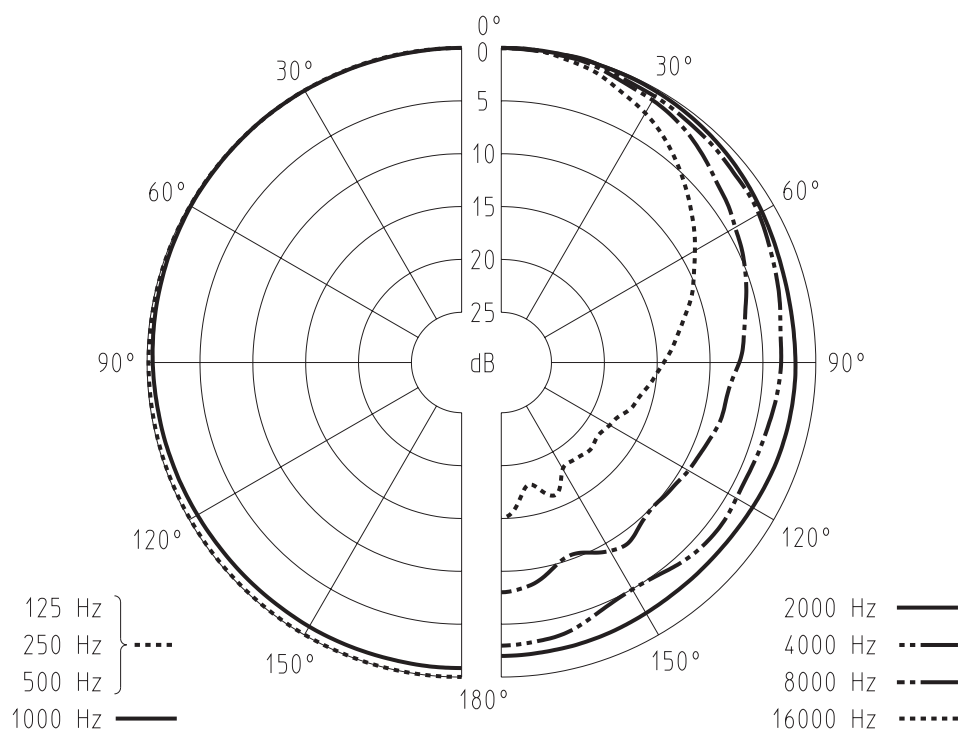

Exploded view

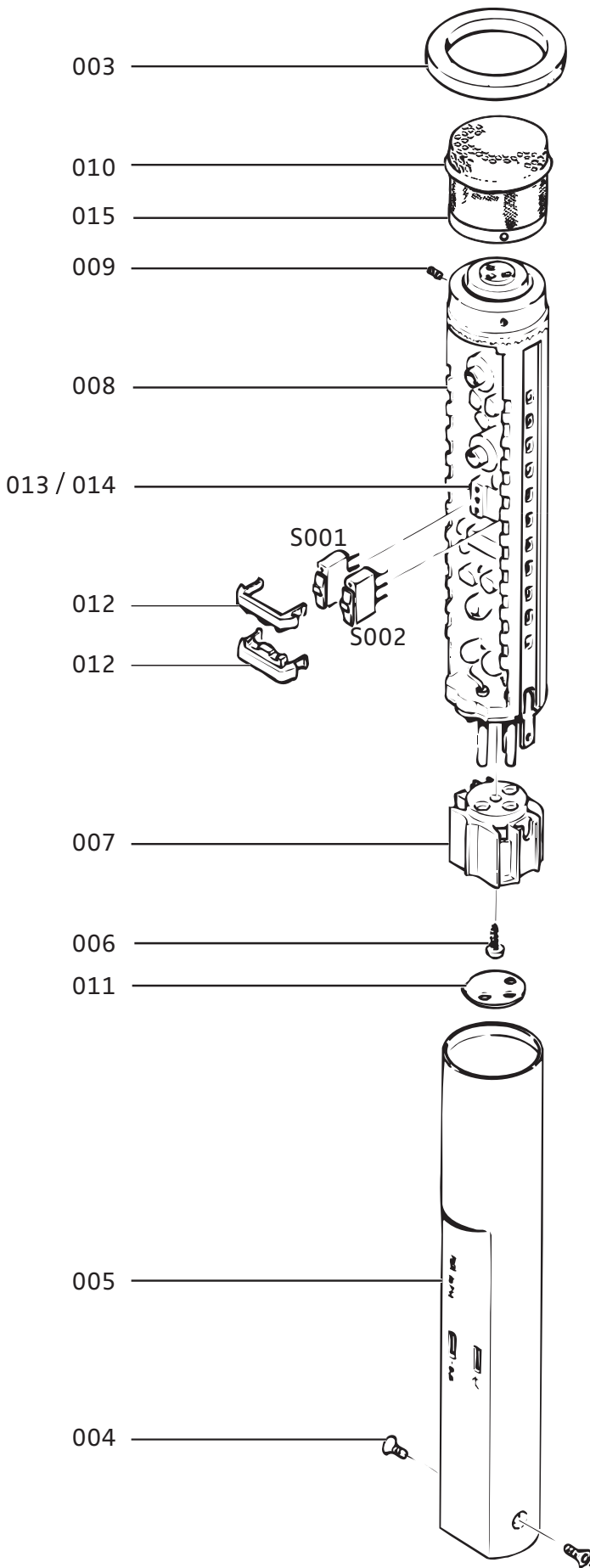

| Pos | Designation |
|------|--|
| 001 | Easy release clamp |
| 002 | Thread insert |
| 003 | Damping ring |
| 004 | Countersunk screw hexagon socket M2.5x4 |
| 005 | Housing MKH20 |
| 006 | Metal screw ST2.2x6.5 |
| 007 | Connecting shell for XLR3 |
| 008 | Chassis complete |
| 009 | Countersunk screw M2x3 |
| 010 | Condenser capsule KS20 |
| 011 | Type plate MKH20 |
| 012 | Brace |
| 013 | IC mounting DIL6 |
| 014 | Plate |
| 015 | O ring 18x1 (for condenser capsule version 2) |
| S001 | Slide switch |
| S002 | Slide switch |

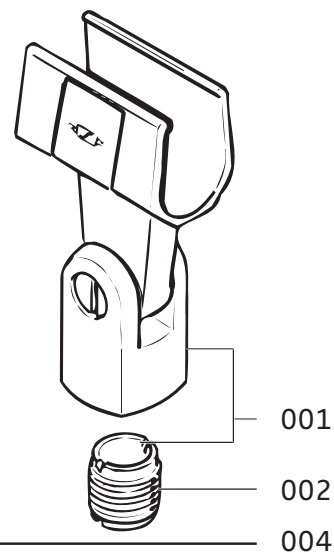

Schematic representations

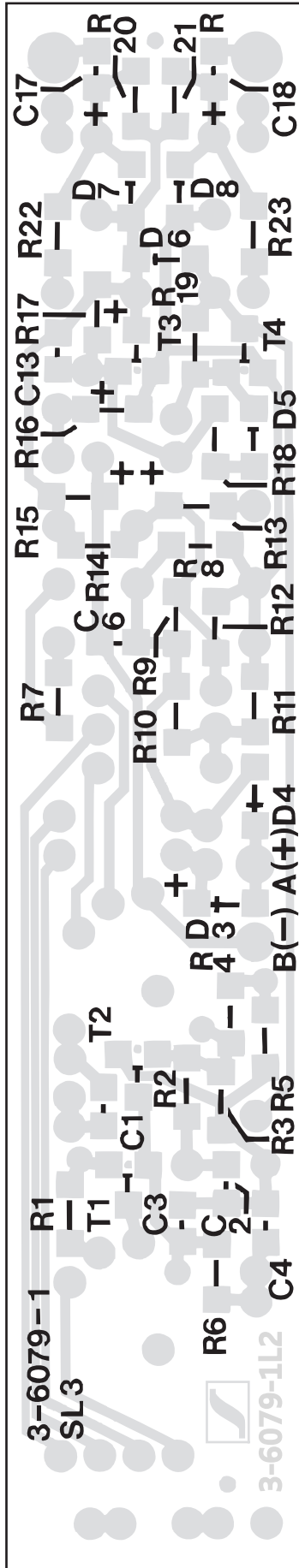

MKH 20, component side

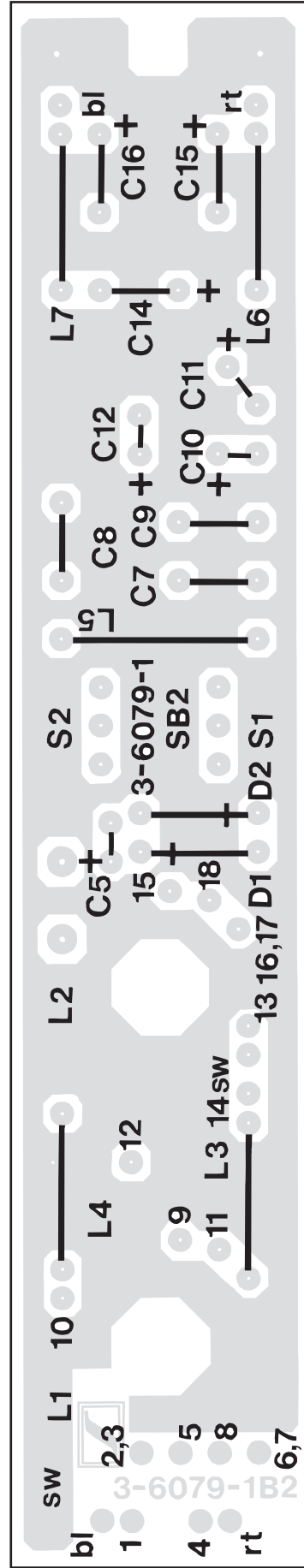

MKH 20, solder side

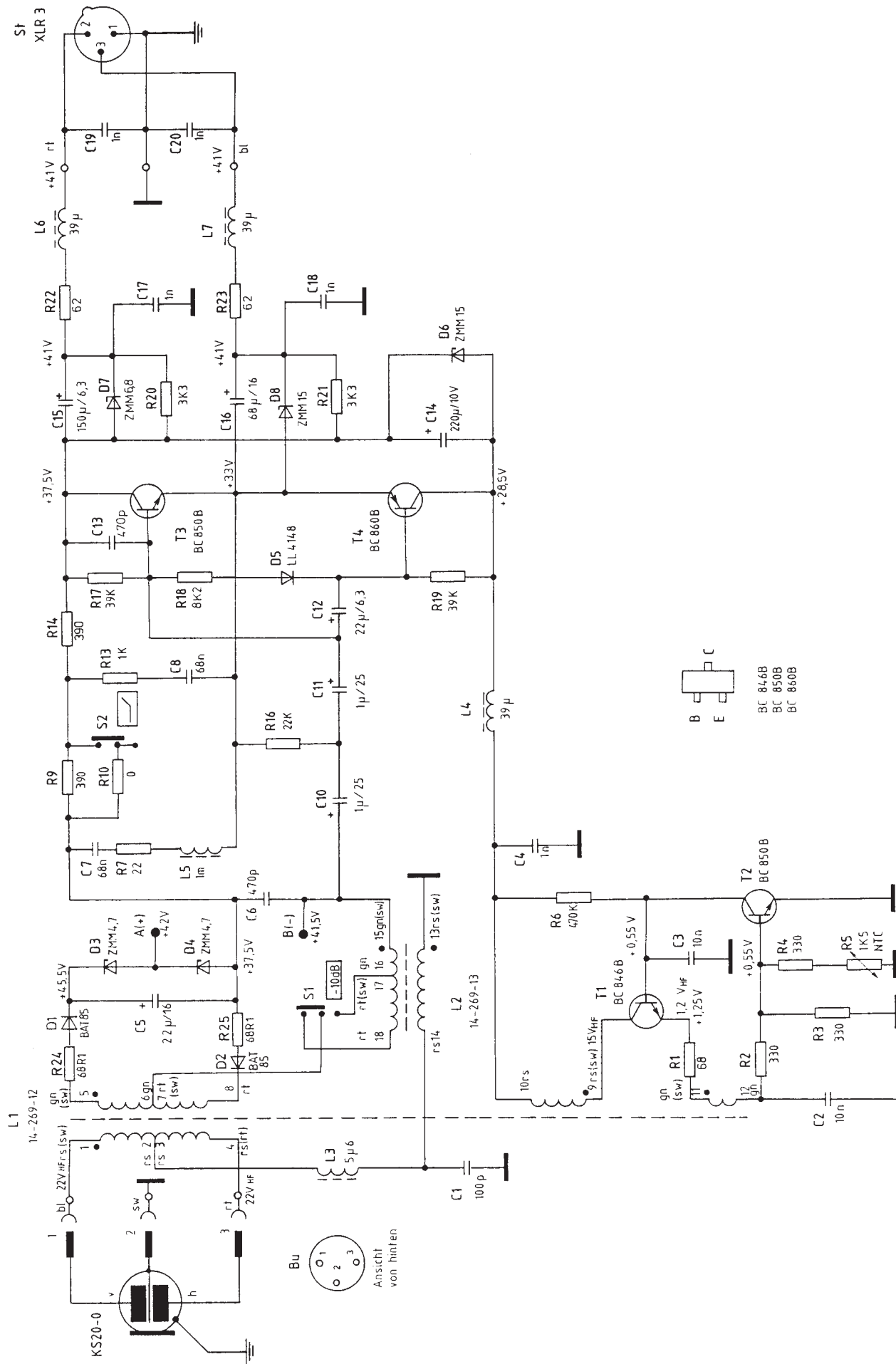

MKH 20, circuit diagram

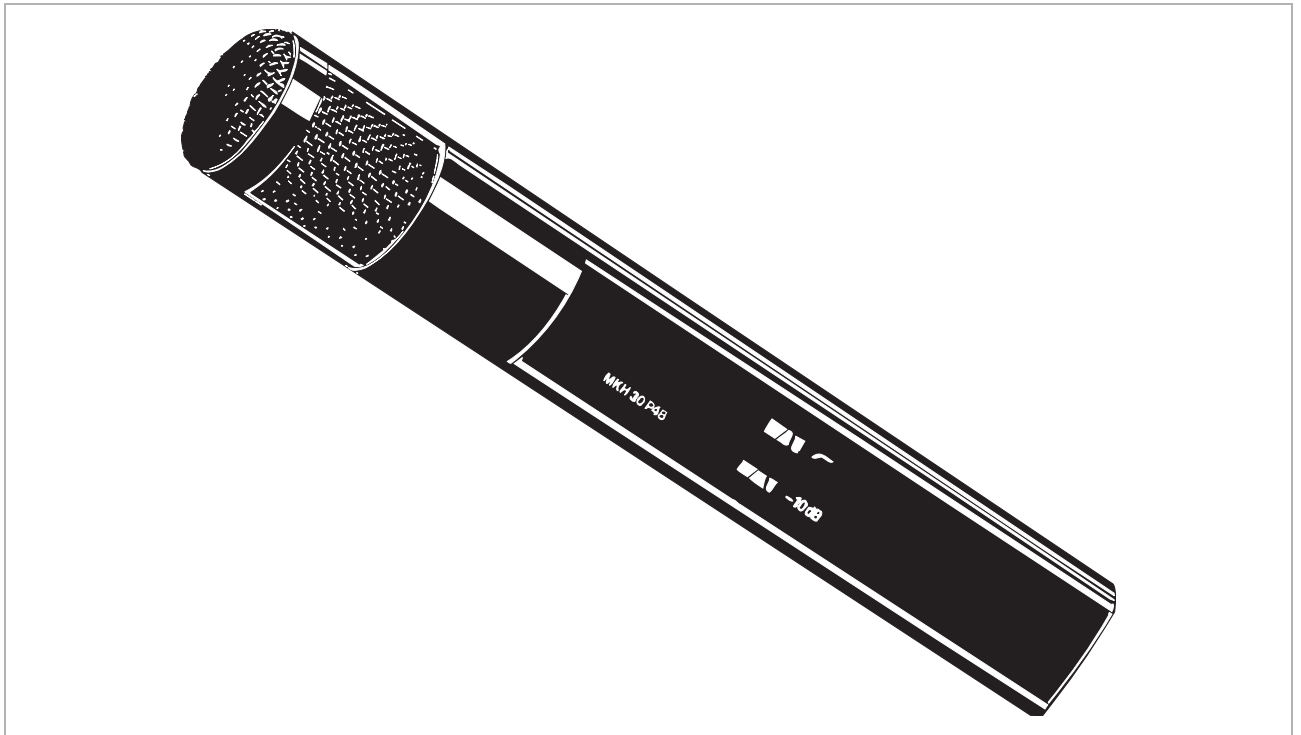
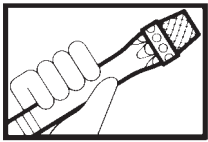

MKH 30 P 48

Brief description

The MKH 30 P 48 is a high-frequency condenser microphone with bidirectional characteristic.

Features

- Very low noise for highly dynamical recordings
- Distortion-free transmission of sound pressures of up to 142dB
- Transmission range 40 to 20000Hz
- Balanced transformer-free signal decoupling
- Switchable roll-off filter
- Switchable pre-attenuation

Subject to alterations

Controls

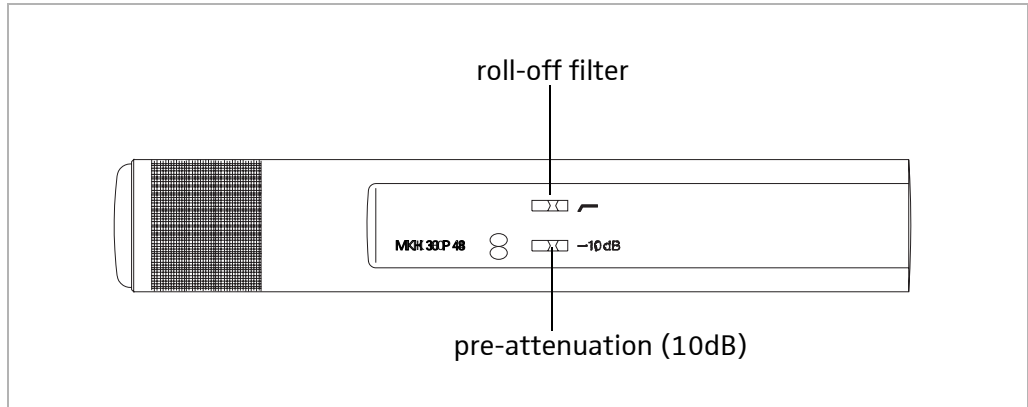

Technical Data

The values in parentheses apply to activated pre-attenuation (-10dB)

| | |
|---|--|
| Acoustic principle | Pressure gradient receiver |
| Directional characteristic | bidirectional |
| Transmission range | 40 to 20000Hz |
| Free-field no-load transmission factor at 1kHz | 25mV/Pa (8mV/Pa) = -32dBV (-42dBV) |
| Equivalent sound pressure level according to DIN 45500, curve A | 13dB (19dB) |
| Equivalent sound pressure level according to DIN 45405/CCIR 468 | 22dB (28dB) |
| Max. sound pressure level | 134dB (142dB) |
| Output | balanced, transformer-free |
| Electrical impedance at 1kHz | 150Ω |
| Min. terminating impedance | 1000Ω |
| Pre-attenuation | 10dB, switchable |
| Low-cut filter (cut-off) | 12dB/oct below 30Hz |
| Roll-off filter | additional 4dB reduction at 50Hz |
| Plug-in connection | XLR3 |
| Connector layout | 1: -, housing 2: +, AF+ 3: +, AF- |
| Power supply | Phantom supply 48V |
| Supply voltage | 48V ±4V |
| Supply current | 2mA |
| Dimensions (in mm) | 25 Ø x 150 |
| Weight | approx. 110g |
| Scope of delivery | 1 microphone MKH 30 P 48, 1 floorstand clamp MZQ 40, 1 close-talking and wind protection MZW 41 |

Frequency response

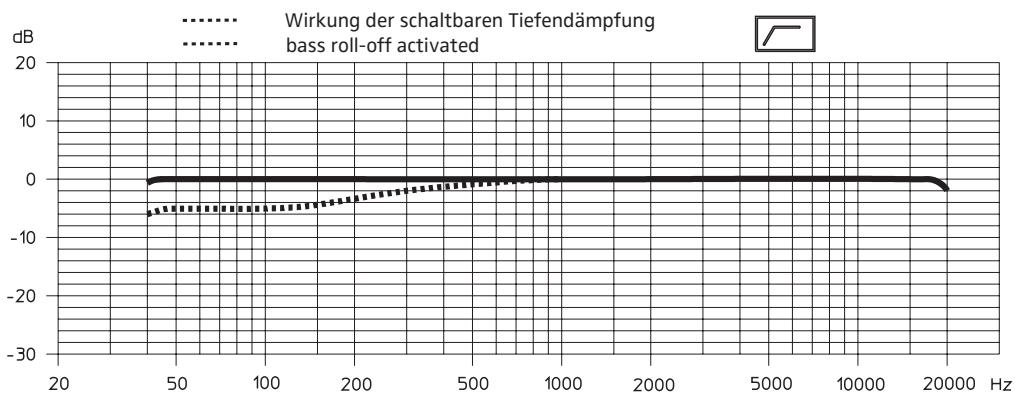

Polar diagram

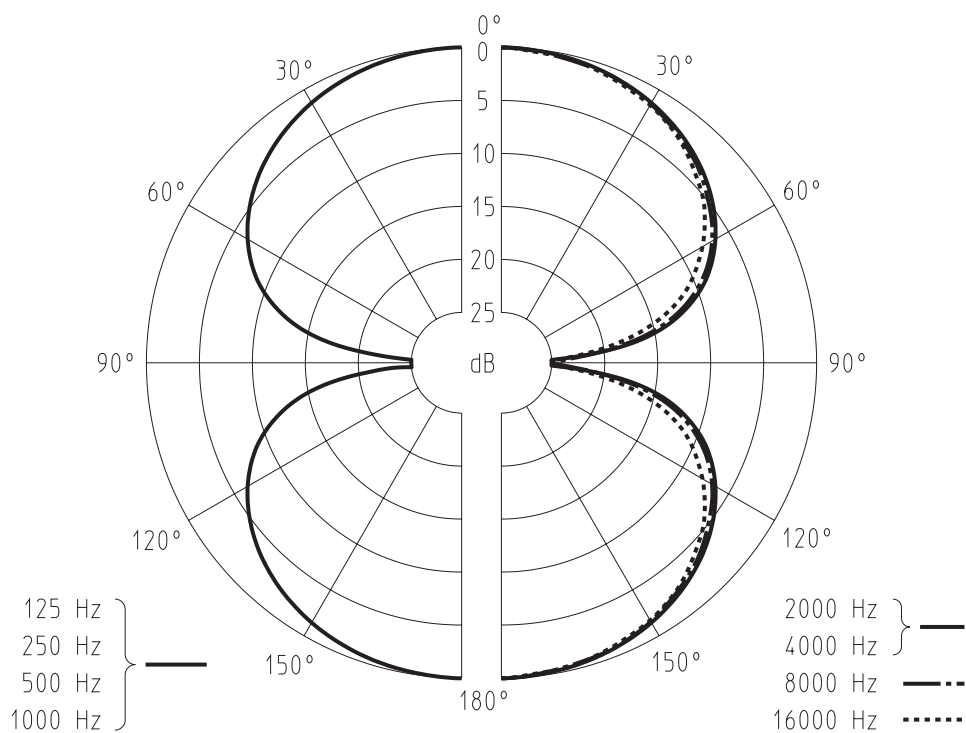

Exploded view

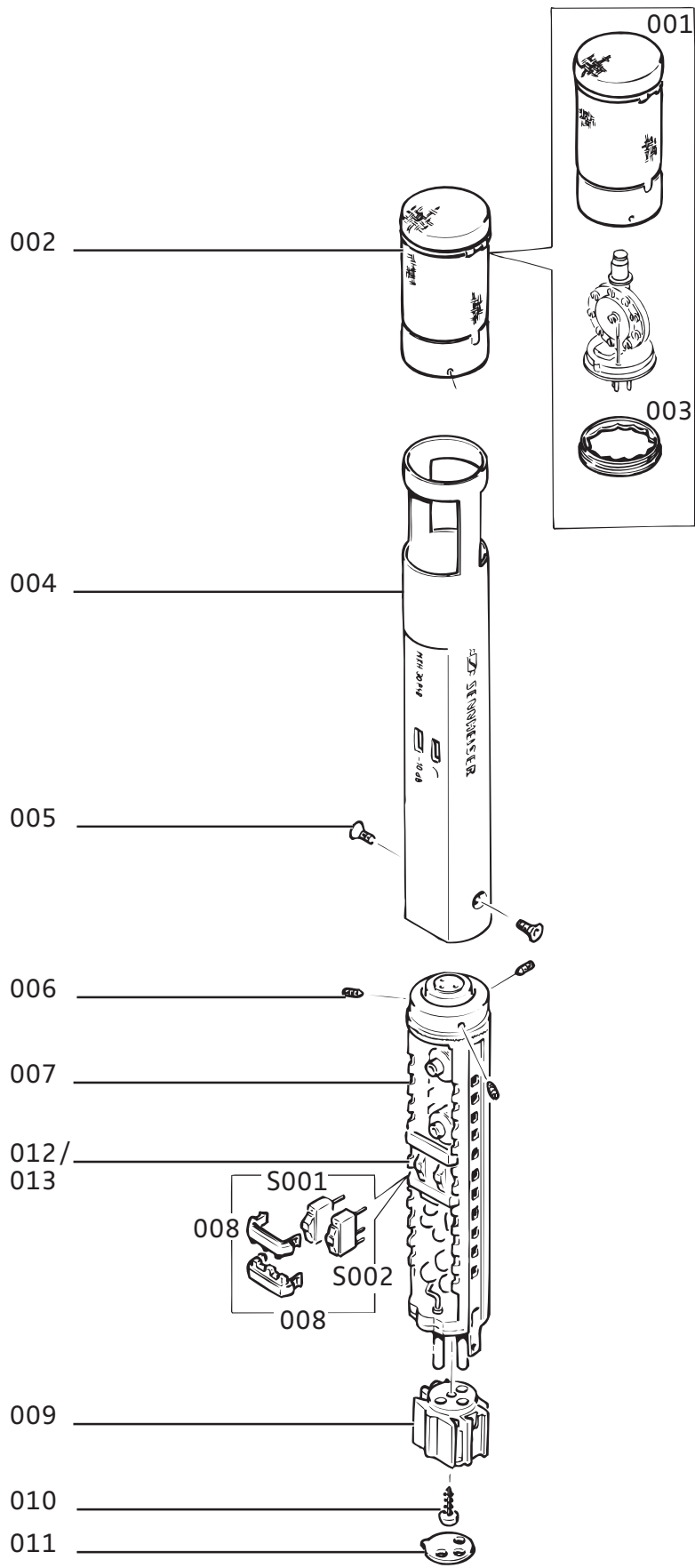

| Pos | Designation |
|------|--|
| 001 | Sound inlet complete with gauze |
| 002 | Condenser capsule KS30 |
| 003 | Thread ring |
| 004 | Housing MKH30 |
| 005 | Countersunk screw hexagon socket M2.5x4 |
| 006 | Countersunk screw M2x3 |
| 007 | Chassis complete |
| 008 | Brace |
| 009 | Connecting shell for XLR3 |
| 010 | Metal screw ST2.2x6.5 |
| 011 | Type plate MKH30 |
| 012 | IC mounting DIL6 |
| 013 | Plate |
| 014 | Easy release clamp |
| 015 | Thread insert |
| 016 | O ring 18x1 (for condenser capsule version 2) |
| S001 | Slide switch |
| S002 | Slide switch |

Schematic representations

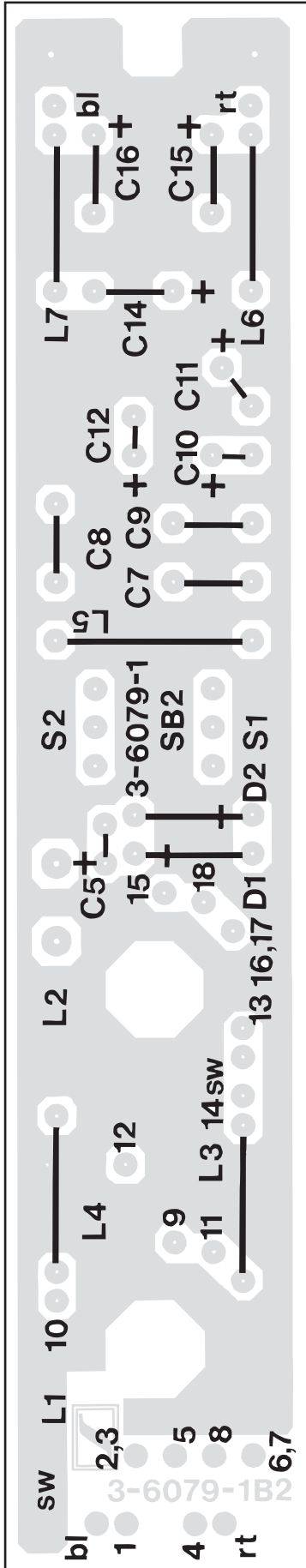

MKH 30, component side

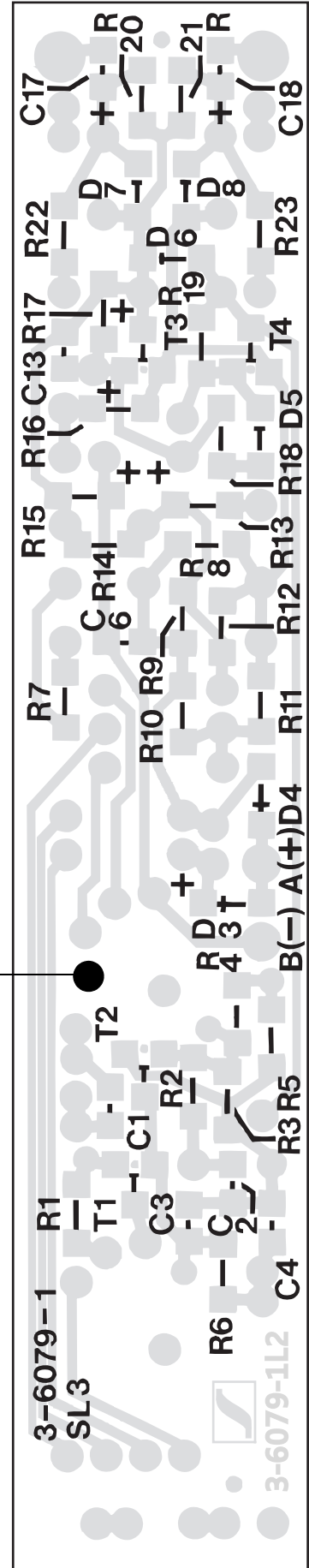

MKH 30, solder side

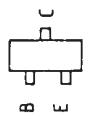
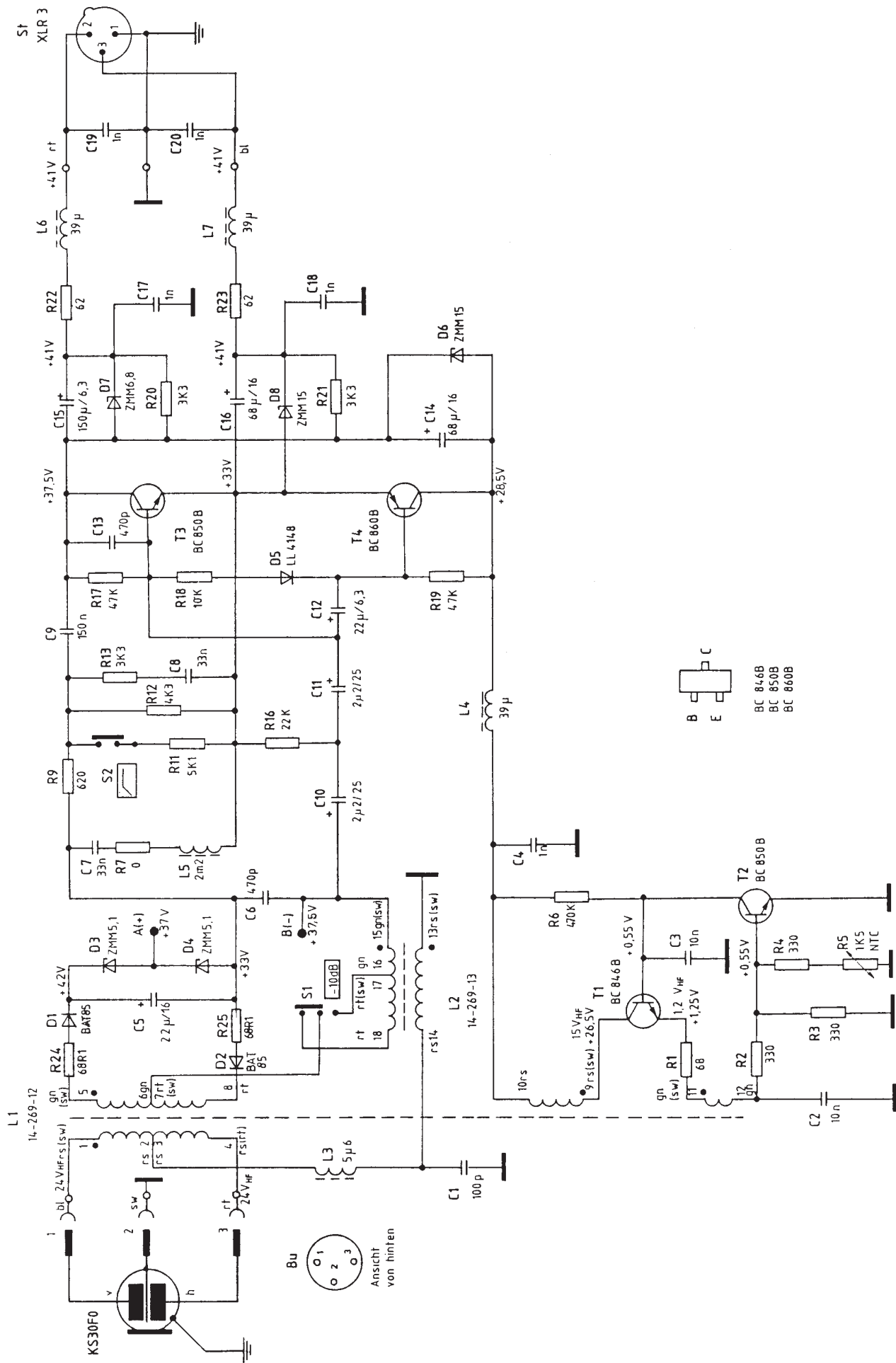

BC 846B
BC 850B
BC 860B

MKH 30, circuit diagram

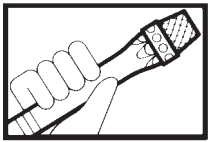

MKH 40 P 48

Brief description

The MKH 40 P48 is a high-frequency condenser microphone with cardioid characteristic.

Features

- Very low noise for highly dynamical recordings
- Largely frequency-independent directional characteristic
- Broad transmission range
- Balanced transformer-free signal decoupling
- Switchable roll-off filter
- Switchable pre-attenuation

Subject to alterations

Controls

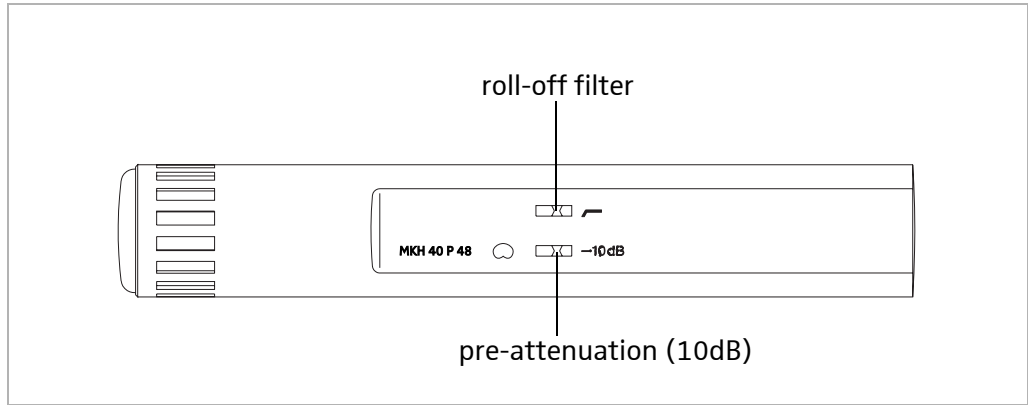

Technical Data

The values in parentheses apply to activated pre-attenuation (-10dB)

| | | |
|---|-------|--|
| Acoustic principle | _____ | Pressure gradient receiver |
| Directional characteristic | _____ | cardioid |
| Transmission range | _____ | 40 to 20000Hz |
| Free-field no-load transmission factor at 1kHz | _____ | 25mV/Pa (8mV/Pa) = -32dBV (-42dBV) |
| Equivalent sound pressure level according to DIN 45500, curve A | _____ | 12dB (16dB) |
| Equivalent sound pressure level according to DIN 45405/CCIR 468 | _____ | 21dB (26dB) |
| Max. sound pressure level | _____ | 134dB (142dB) |
| Output | _____ | balanced, transformer-free |
| Electrical impedance at 1kHz | _____ | 150Ω |
| Min. terminating impedance | _____ | 1000Ω |
| Pre-attenuation | _____ | 10dB, switchable |
| Low-cut filter (cut-off) | _____ | 12dB/oct below 30Hz |
| Roll-off filter | _____ | additional 4dB reduction at 50Hz |
| Plug-in connection | _____ | XLR3 |
| Connector layout | _____ | 1: -, housing 2: +, AF+ 3: +, AF- |
| Power supply | _____ | Phantom supply 48V |
| Supply voltage | _____ | 48V ±4V |
| Supply current | _____ | 2mA |
| Dimensions (in mm) | _____ | 25 Ø x 150 |
| Weight | _____ | approx. 110g |
| Scope of delivery | _____ | 1 microphone MKH 40 P 48, 1 floorstand clamp MZQ 40, 1 close-talking and wind protection MZW 41 |

Frequency response

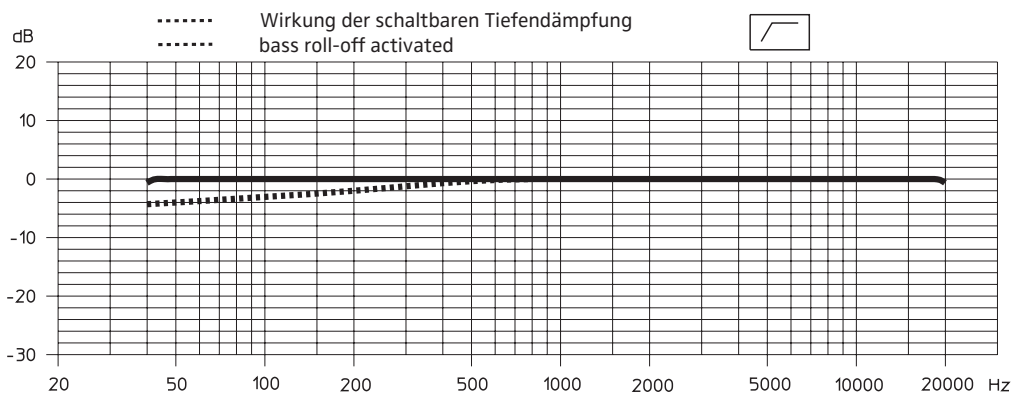

Polar diagram

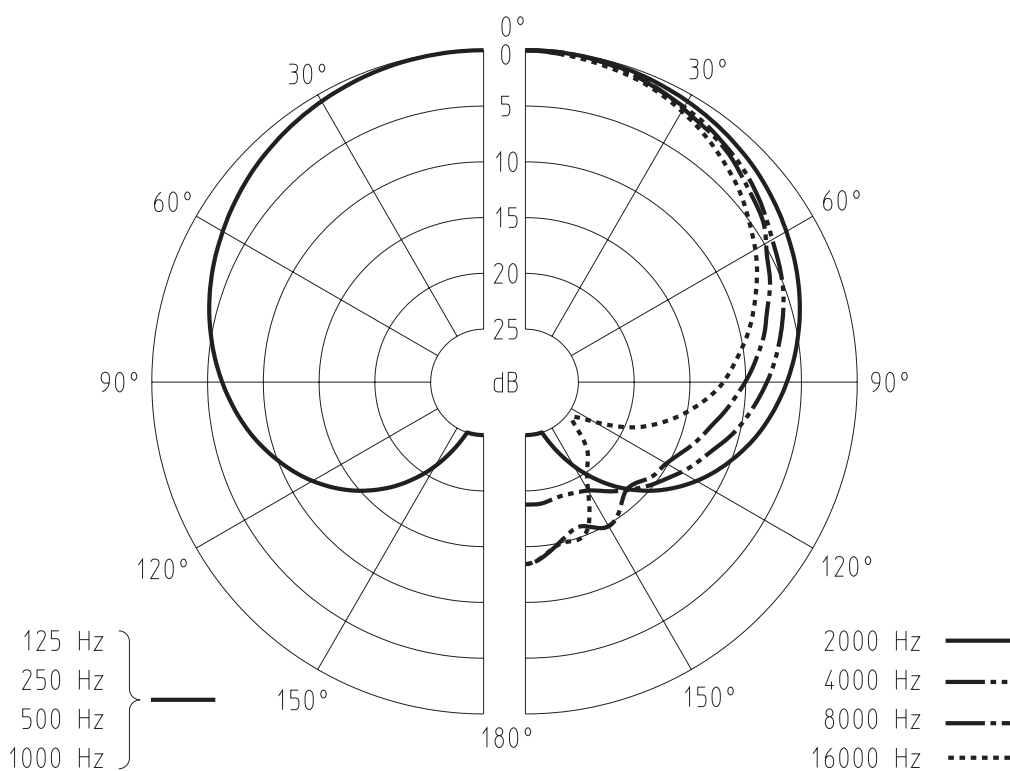

Exploded view

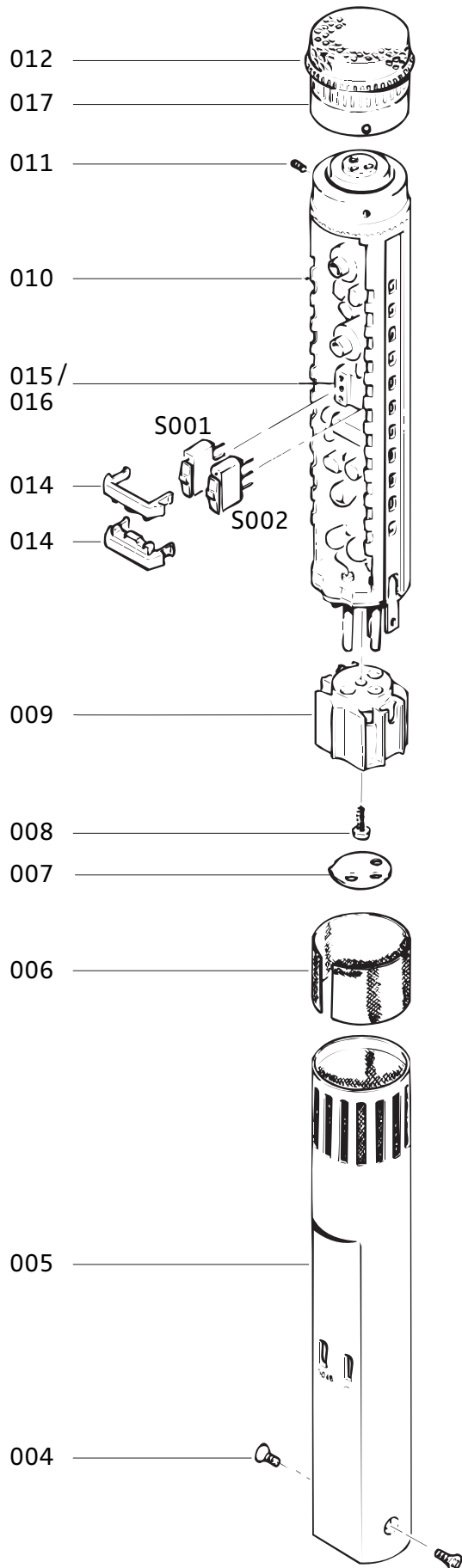

| Pos | Designation |
|------|---|
| 001 | Easy release clamp |
| 002 | Thread insert |
| 004 | Countersunk screw hexagon socket M2.5x4 |
| 005 | Housing MKH40 |
| 006 | Damping silk |
| 007 | Type plate MKH40 |
| 008 | Metal screw ST2.2x6.5 |
| 009 | Connecting shell for XLR3 |
| 010 | Chassis complete |
| 011 | Countersunk screw M2x3 |
| 012 | Condenser capsule KS40 |
| 014 | Brace |
| 015 | IC mounting DIL6 |
| 016 | Plate |
| 017 | O ring 18x1 |
| S001 | Slide switch |
| S002 | Slide switch |

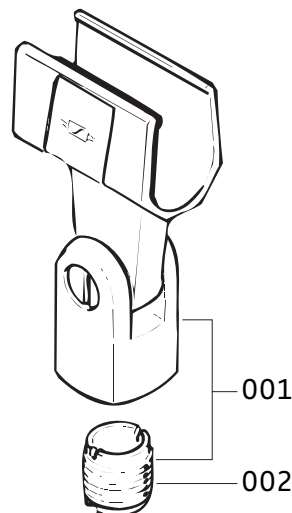

Schematic representations

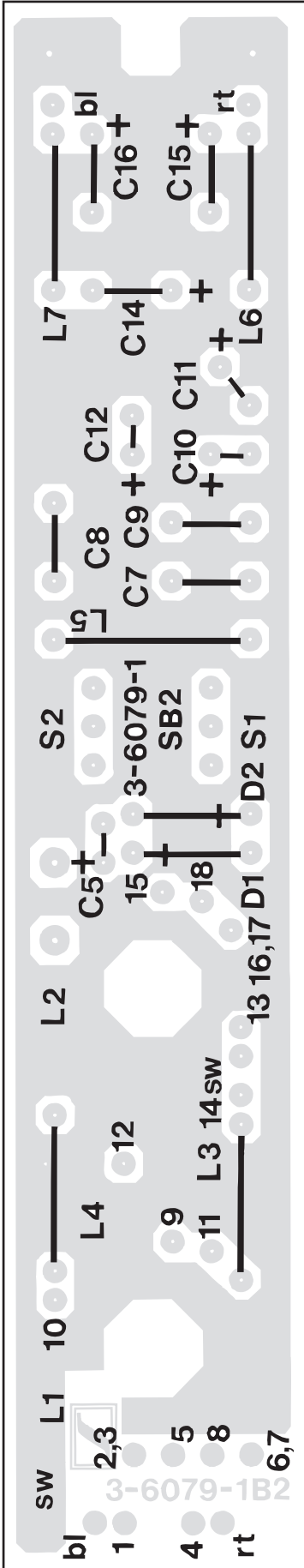

MKH 40, component side

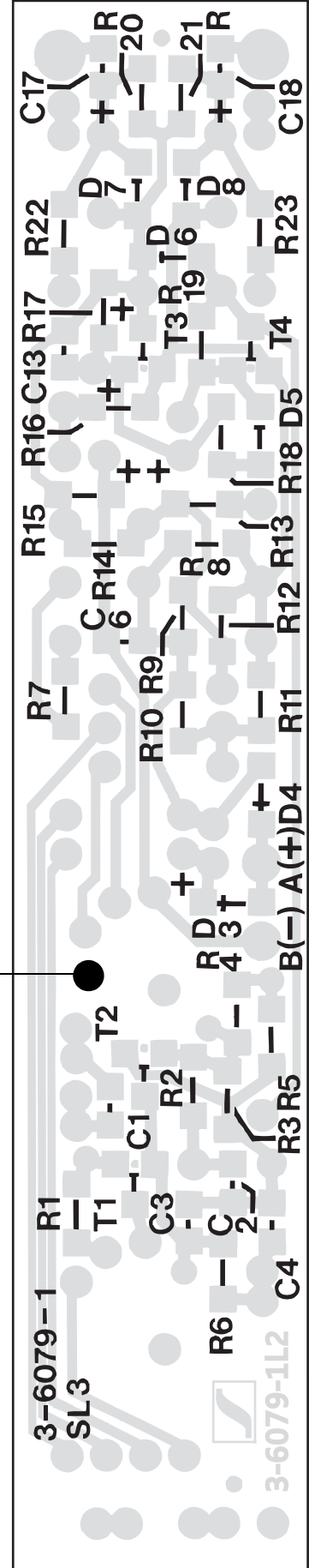

MKH 40, solder side

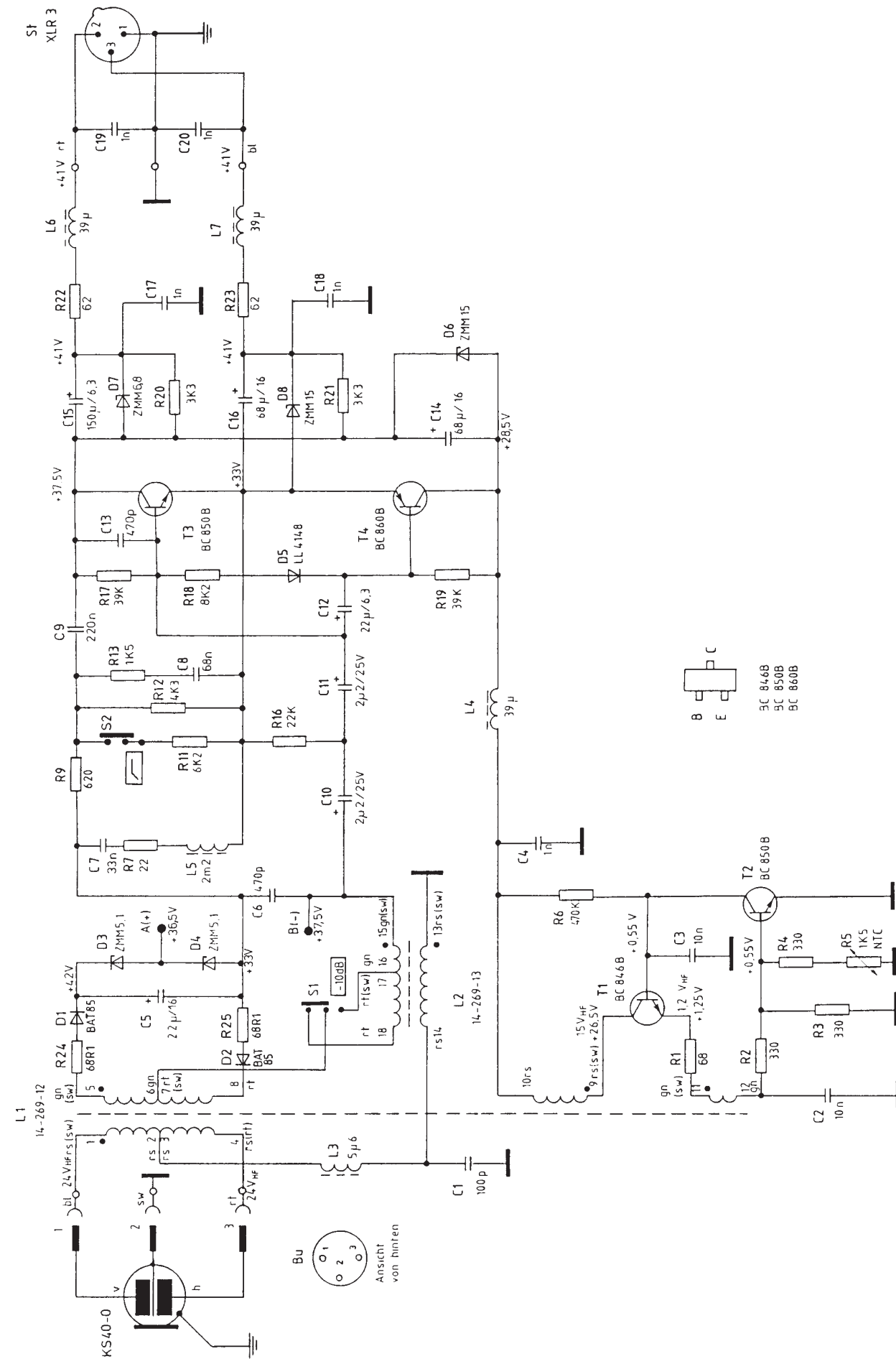

MKH 40, circuit diagram

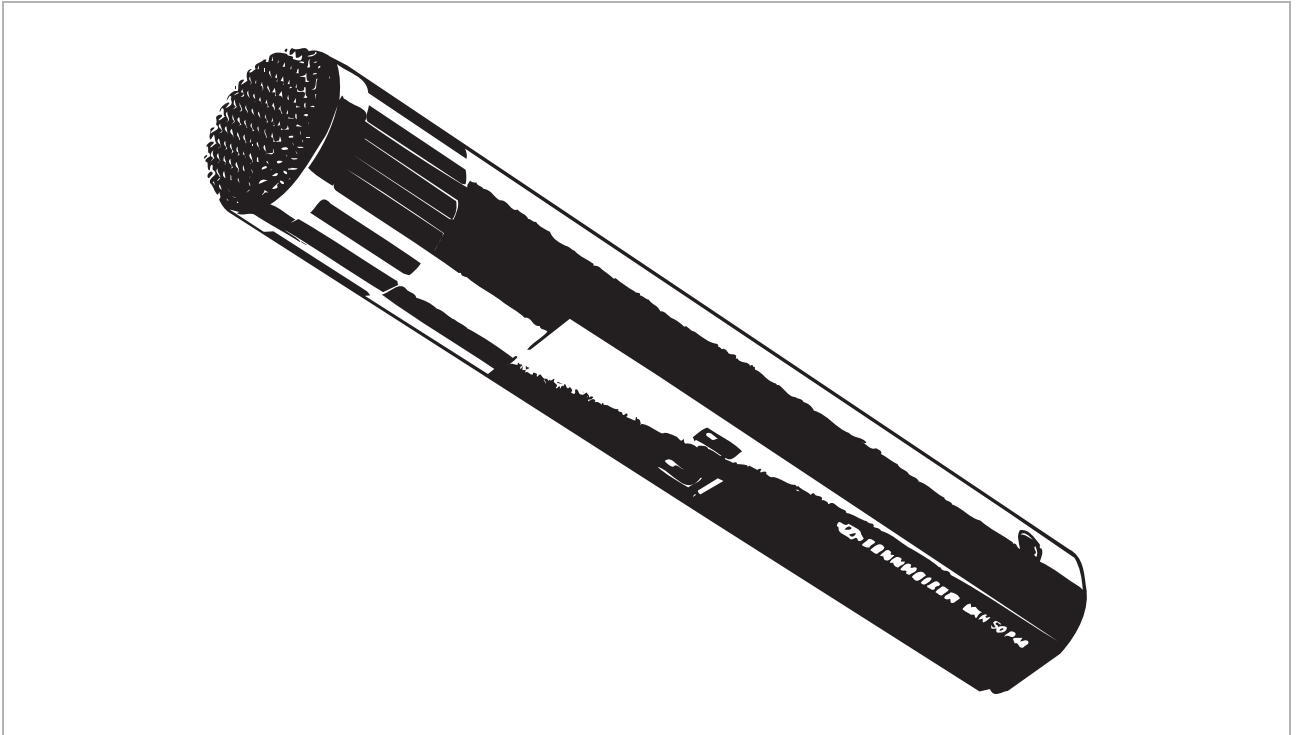
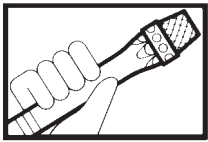

MKH 50 P 48

Brief description

The MKH 50 P 48 is a high-frequency condenser microphone with hyper-cardioid characteristic.

Features

- Very low noise for highly dynamical recordings
- Largely frequency-independent directional characteristic
- Broad transmission range
- Balanced transformer-free signal decoupling
- Switchable roll-off filter
- Switchable pre-attenuation

Subject to alterations

Controls

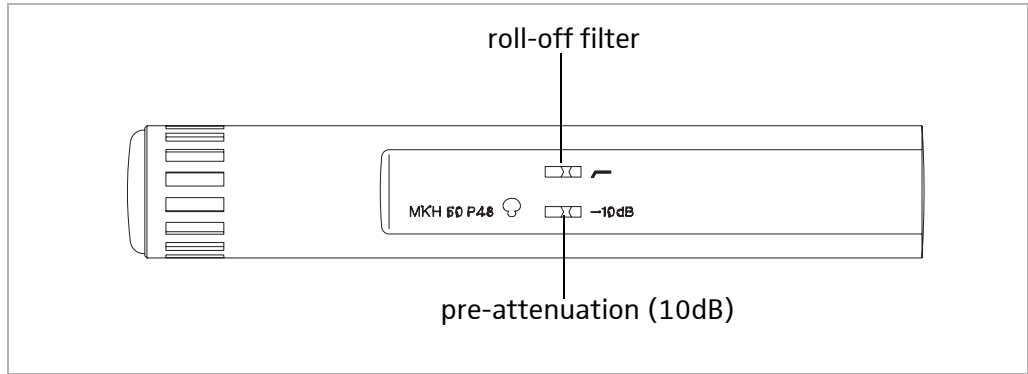

Technical Data

The values in parentheses apply to activated pre-attenuation (-10dB)

| | | |
|--|-------|--|
| Acoustic principle | _____ | Pressure gradient receiver |
| Directional characteristic | _____ | hyper-cardioid |
| Transmission range | _____ | 40 to 20000Hz |
| Free-field no-load transmission factor | | |
| at 1kHz | _____ | 25mV/Pa (8mV/Pa) = -32dBV (-42dBV) |
| Equivalent sound pressure level | | |
| according to DIN 45500, curve A | _____ | 12dB (18dB) |
| Equivalent sound pressure level | | |
| according to DIN 45405/CCIR 468 | _____ | 21dB (27dB) |
| Max. sound pressure level at 1kHz | _____ | 134dB (142dB) |
| Output | _____ | balanced, transformer-free |
| Electrical impedance at 1kHz | _____ | 150Ω |
| Min. terminating impedance | _____ | 1000Ω |
| Pre-attenuation | _____ | 10dB, switchable |
| Low-cut filter (cut-off) | _____ | 12dB/oct below 30Hz |
| Roll-off filter | _____ | additional 4dB reduction at 50Hz |
| Plug-in connection | _____ | XLR3 |
| Connector layout | _____ | 1: -, housing 2: +, AF+ 3: +, AF- |
| Power supply | _____ | Phantom supply 48V |
| Supply voltage | _____ | 48V ±4V |
| Supply current | _____ | 2mA |
| Dimensions (in mm) | _____ | 25 Ø x 150 |
| Weight | _____ | approx. 100g |
| Scope of delivery | _____ | 1 microphone MKH 50 P 48, 1 floorstand clamp MZQ 40, 1 close-talking and wind protection MZW 41 |

Frequency response

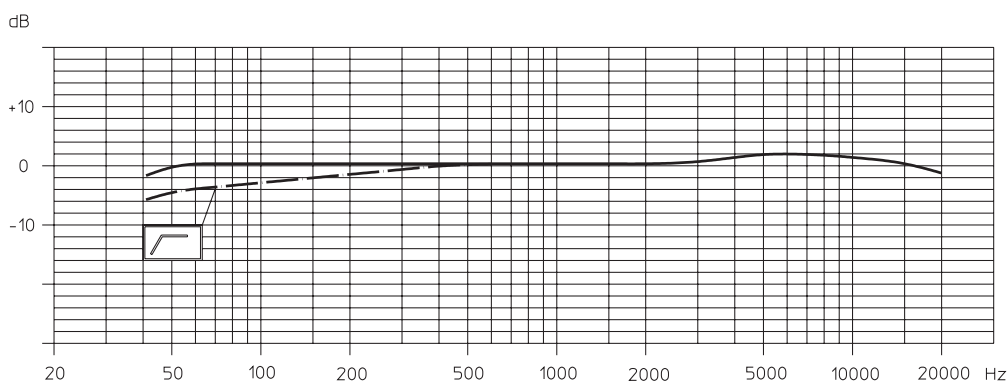

Equalization

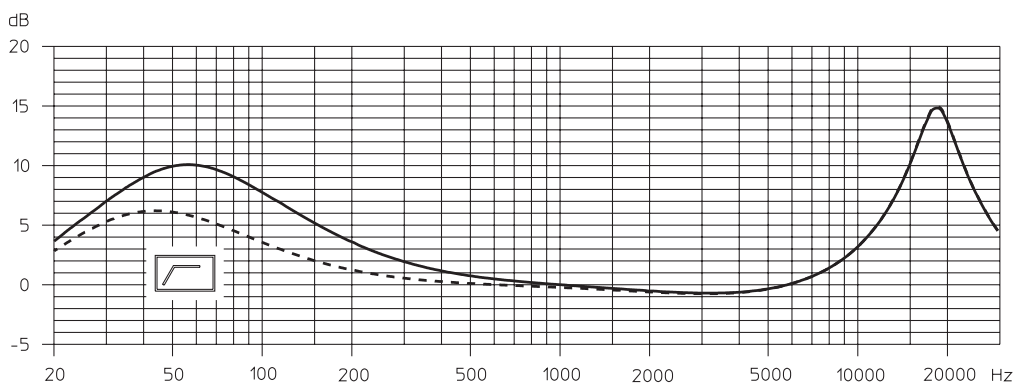

Polar diagram

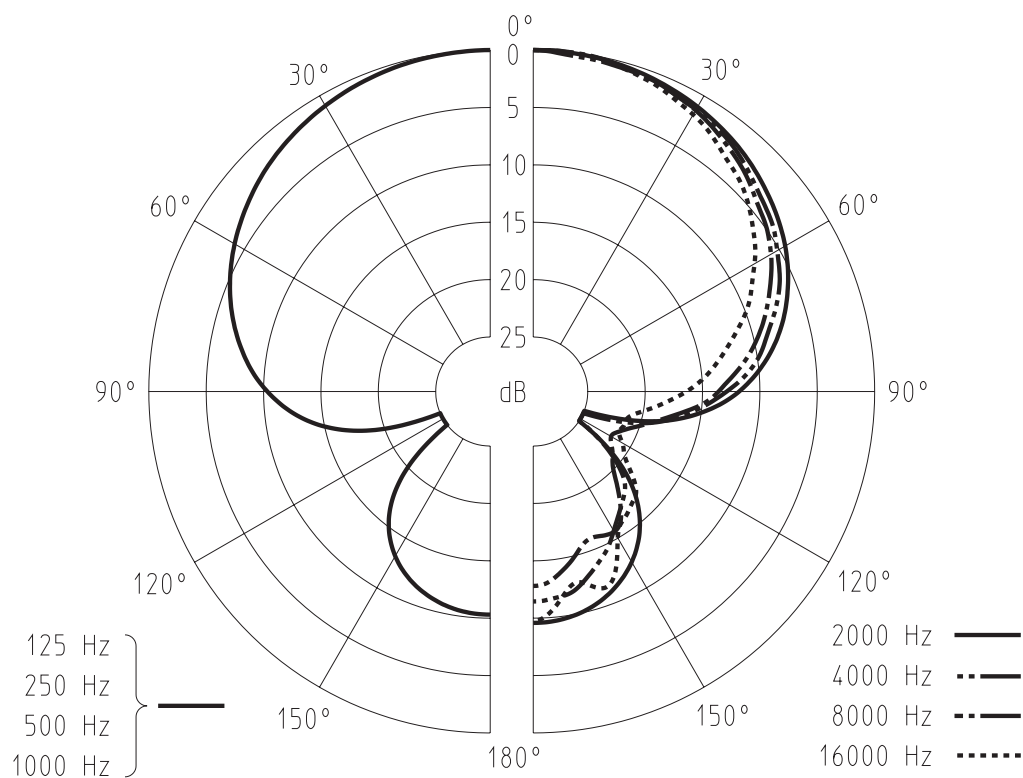

Exploded view

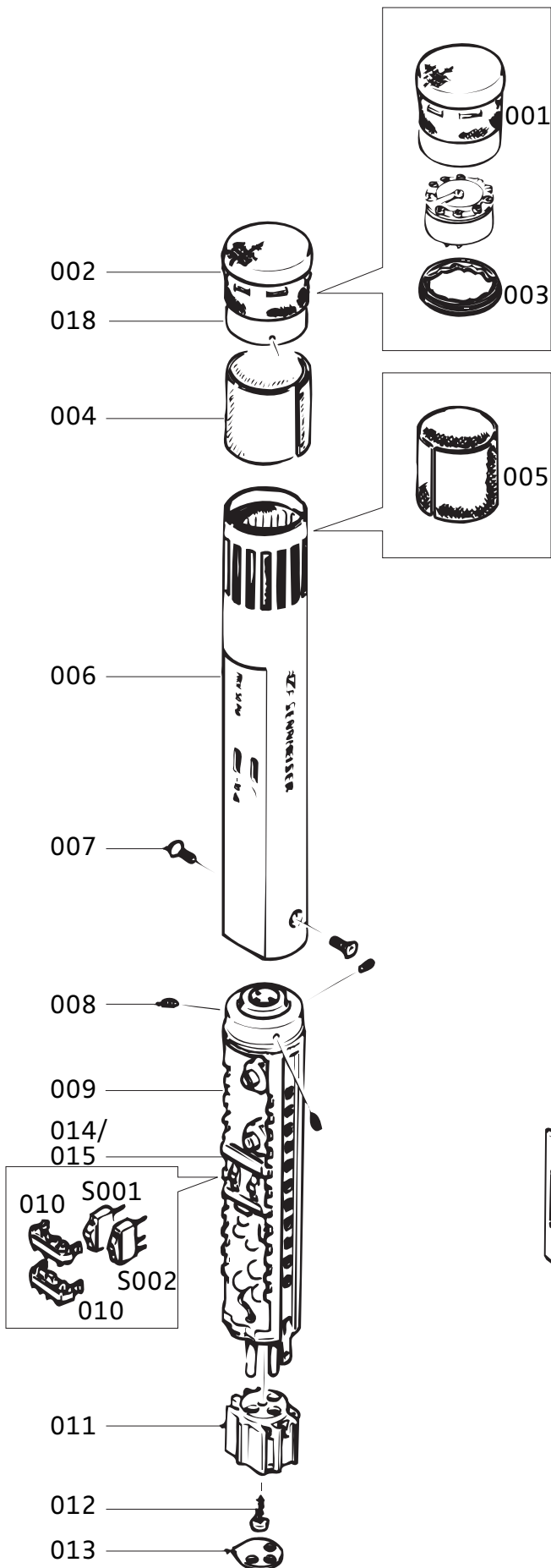

| Pos | Designation |
|------|--|
| 001 | Sound inlet complete with gauze |
| 002 | Condenser capsule KS50 |
| 003 | Thread ring |
| 004 | Damping silk |
| 005 | Dust protection |
| 006 | Housing MKH50 |
| 007 | Countersunk screw hexagon socket M2.5x4 |
| 008 | Countersunk screw M2x3 |
| 009 | Chassis complete |
| 010 | Brace |
| 011 | Connecting shell for XLR3 |
| 012 | Metal screw ST2.2x6.5 |
| 013 | Type plate MKH50 |
| 014 | IC mounting DIL6 |
| 015 | Plate |
| 016 | Easy release clamp |
| 017 | Threaded insert |
| 018 | O ring 18x1 (for condenser capsule version 2) |
| S001 | Slide switch |
| S002 | Slide switch |

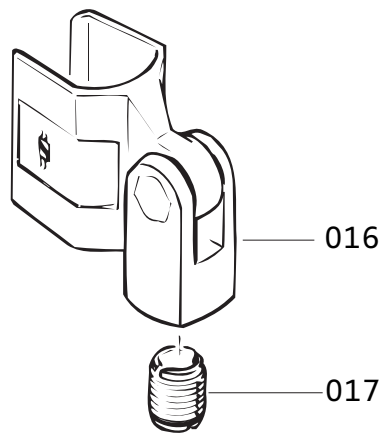

Schematic representations

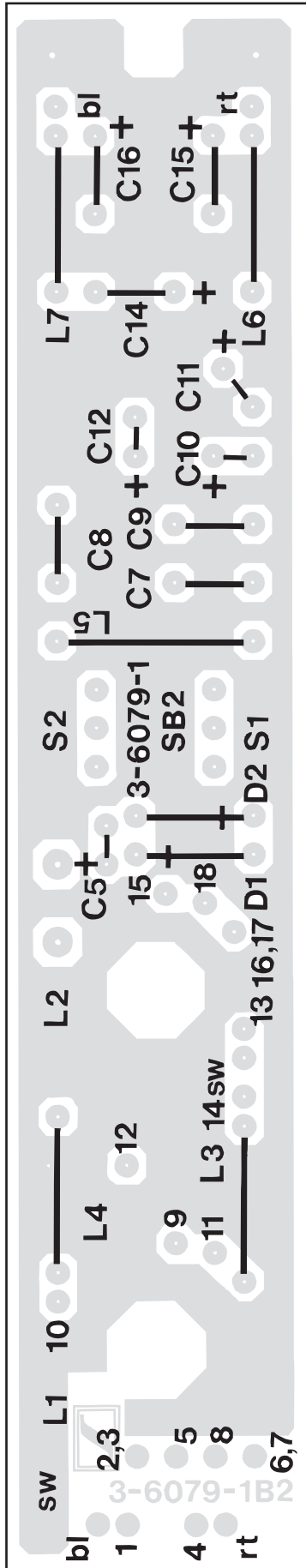

MKH 50, component side

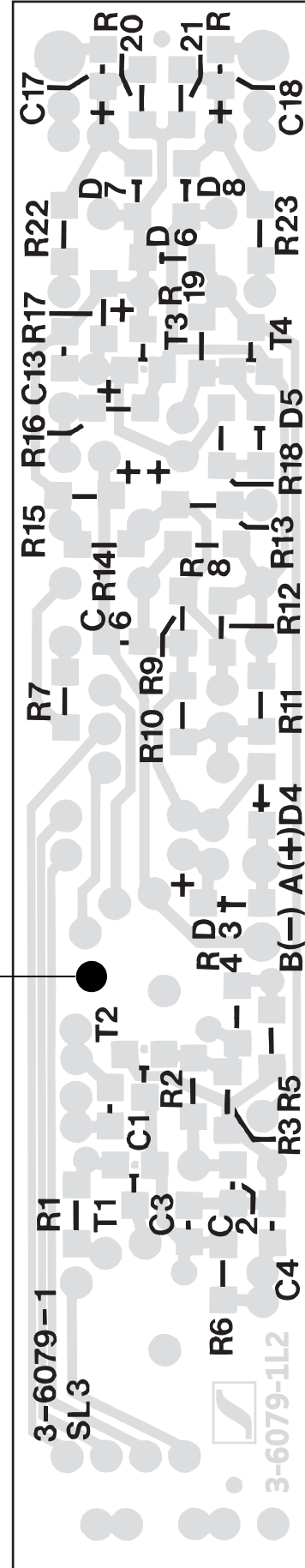

MKH 50, solder side

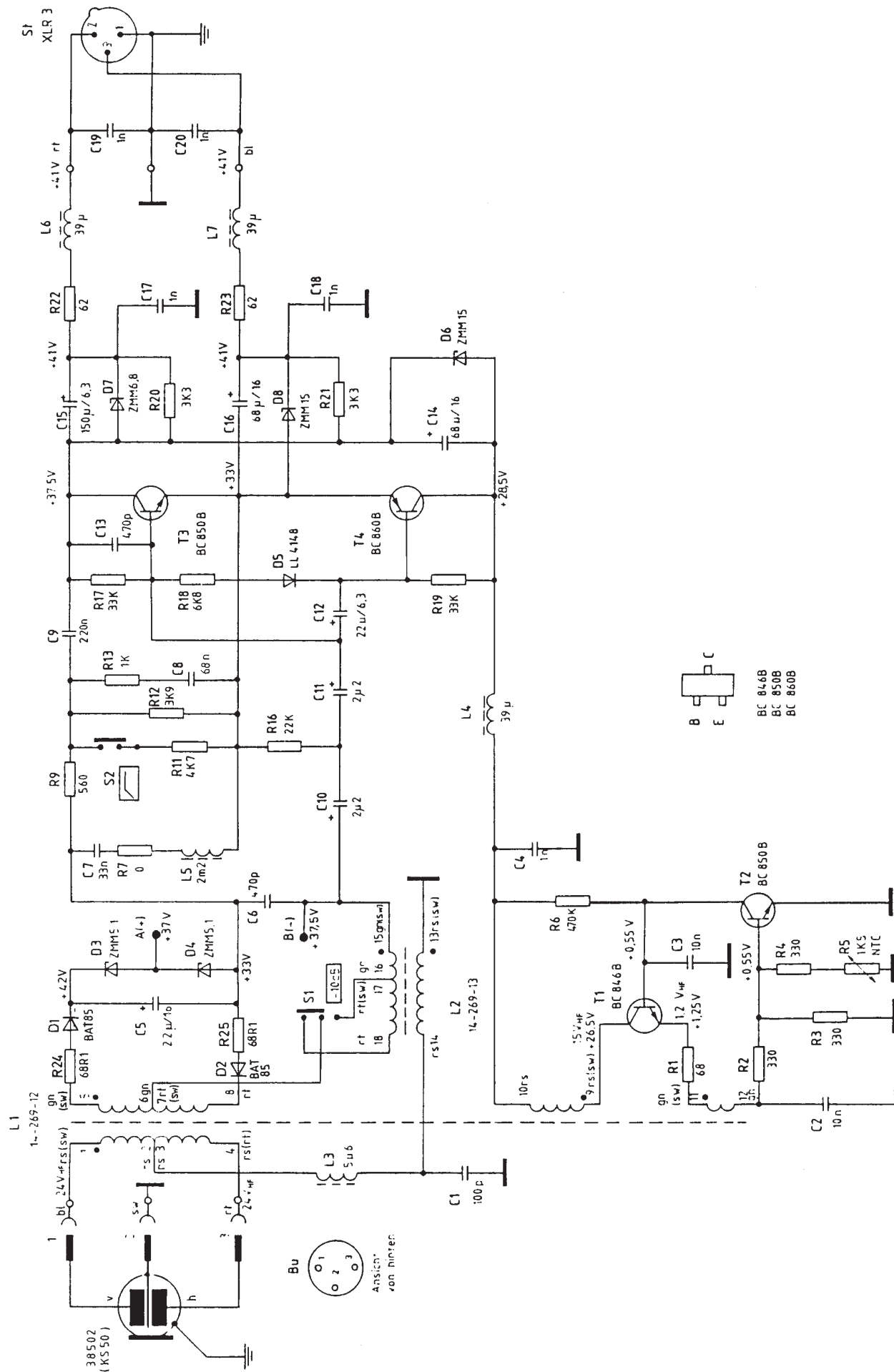

MKH 50, circuit diagram

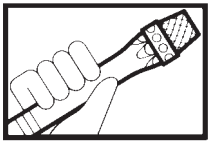

MKH 60-1 P 48

Brief description

The MKH 60-1 P 48 is a high-frequency condenser microphone with hyper-cardioid/lobe characteristic.

Features

- Low noise for highly dynamical recordings
- Uniform directional characteristic
- Broad transmission range
- Switchable pre-attenuation (-10dB)
- Switchable filters (roll-off and presence)

Subject to alterations

Controls

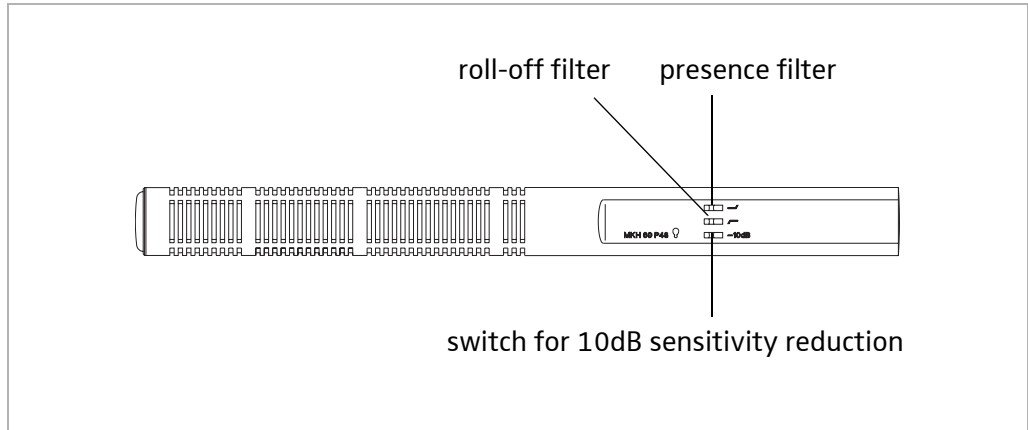

Technical Data

The values in parentheses apply to activated pre-attenuation (-10dB)

| | |
|--|---|
| Acoustic principle _____ | Pressure gradient/ interference receiver |
| Directional characteristic _____ | hyper-cardioid/lobe |
| Transmission range _____ | 50 to 20000Hz |
| Free-field no-load transmission factor at 1kHz _____ | 40mV/Pa (12.5mV/Pa) |
| Equivalent sound pressure level according to DIN 45500, curve A _____ | 9dB (16dB) |
| Equivalent sound pressure level according to DIN 45405/CCIR 468 _____ | 20dB (27dB) |
| Max. sound pressure level at 1kHz _____ | 125dB (135dB) |
| Output _____ | balanced, transformer-free |
| Electrical impedance at 1kHz _____ | 150Ω |
| Min. terminating impedance _____ | 1000Ω |
| Pre-attenuation _____ | 10dB, switchable |
| Low-cut filter (cut-off) _____ | 18dB/oct below 50Hz |
| Roll-off filter _____ | additional 3dB reduction at 70Hz |
| Presence filter _____ | 5dB emphasis at 10kHz |
| Plug-in connection _____ | XLR3 |
| Connector layout _____ | 1: -, housing 2: +, AF+ 3: +, AF- |
| Power supply _____ | Phantom supply 48V |
| Supply voltage _____ | 48V ±4V |
| Supply current _____ | 2mA |
| Dimensions (in mm) _____ | 25 Ø x 285 |
| Weight _____ | approx. 150g |
| Scope of delivery _____ | 1 microphone MKH 60-1 P 48 |

Frequency response

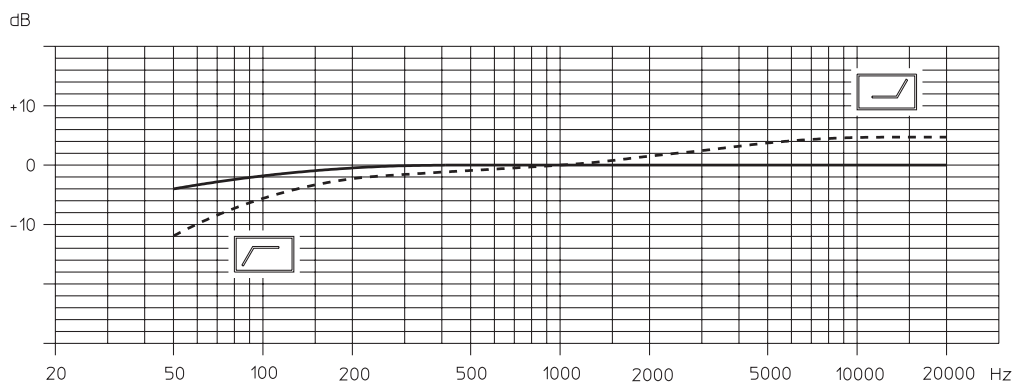

Equalization

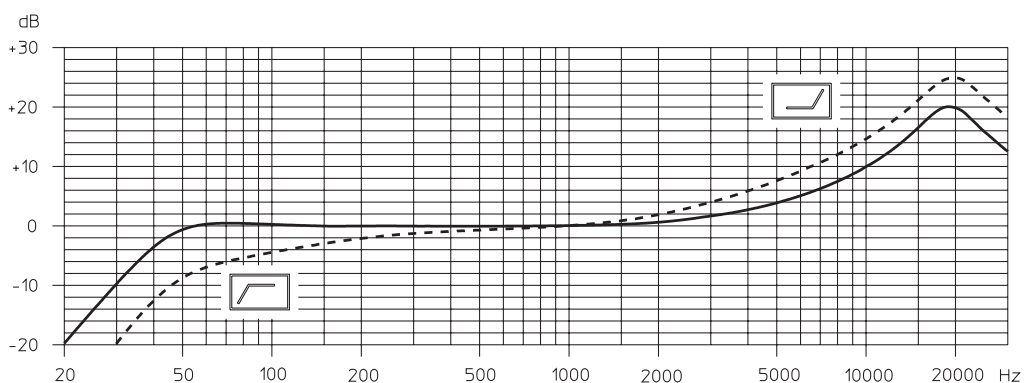

Polar diagram

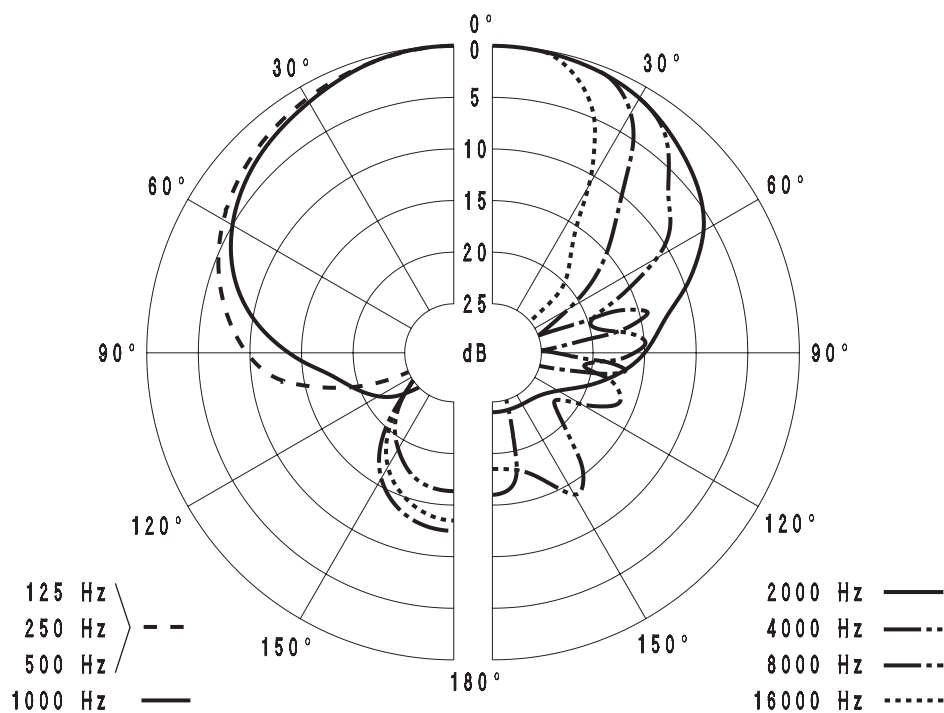

Exploded view

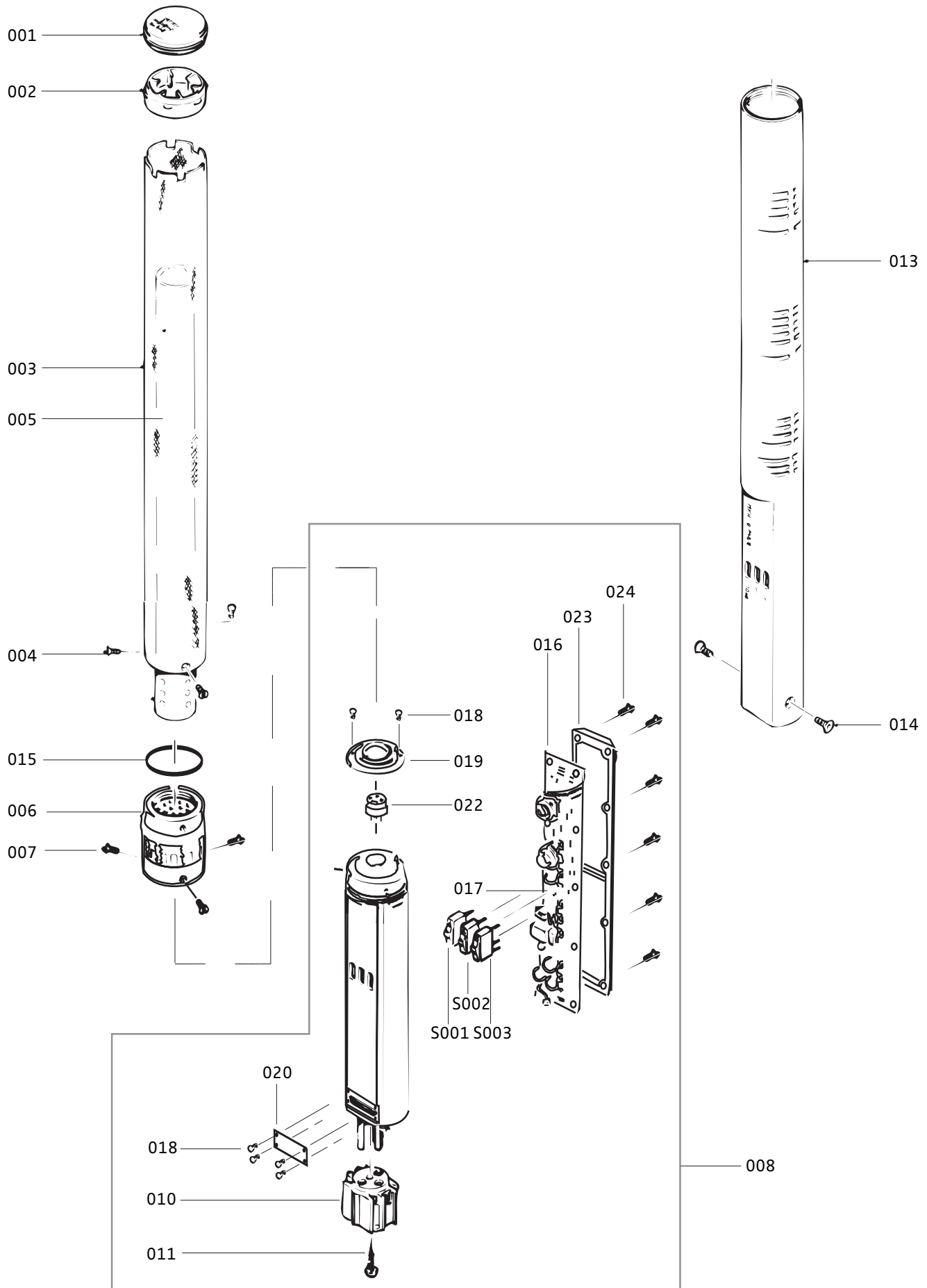

| Pos | Designation |
|------------|---|
| 001 | Sound inlet MKH60/70 |
| 002 | Ring |
| 003 | Gauze tube MKH60 |
| 004 | Countersunk screw M1.4x3 |
| 005 | Tube complete |
| 006 | Condenser capsule KS60 |
| 007 | Countersunk screw M2x3 |
| 008 | Chassis with PCB MKH60-1 |
| 009 | Brace |
| 010 | Connecting shell for XLR3 |
| 011 | Cheese head screw M2x5 |
| 012 | Type plate MKH60-1 |
| 013 | Housing MKH60 |
| 014 | Countersunk screw hexagon socket M2.5x4 |
| 015 | O ring 18x1 |
| 016 | PCB assembly MKH60 |
| 017 | Base for IC |
| 018 | Cheese head screw M1.7x3 |
| 019 | Ring |
| 020 | Sheet metal 16.8x11.4 |
| 021 | Type plate (frequency as order) |
| 022 | Socket contact with rubber ring |
| 023 | Cover 103.4x19.5x3.6 |
| 024 | Cheese head screw M1.7x6 |
| S001 | Slide switch |
| S002 | Slide switch |
| S003 | Slide switch |

| | | | | | | | | | | | | | | | | | | | | | | |
|---|---|---|---|---|---|---|---|---|---|----|----|----|----|----|----|----|----|----|----|----|----|---|
| R | 1 | 2 | 3 | 4 | 5 | 6 | 7 | 8 | 9 | 10 | 11 | 12 | 13 | 14 | 15 | 16 | 17 | 18 | 19 | 20 | 21 | R |
| C | 1 | 2 | 3 | 4 | 5 | 6 | 7 | 8 | 9 | 10 | 11 | 12 | 13 | 14 | 15 | 16 | 17 | 18 | 19 | 20 | 21 | C |

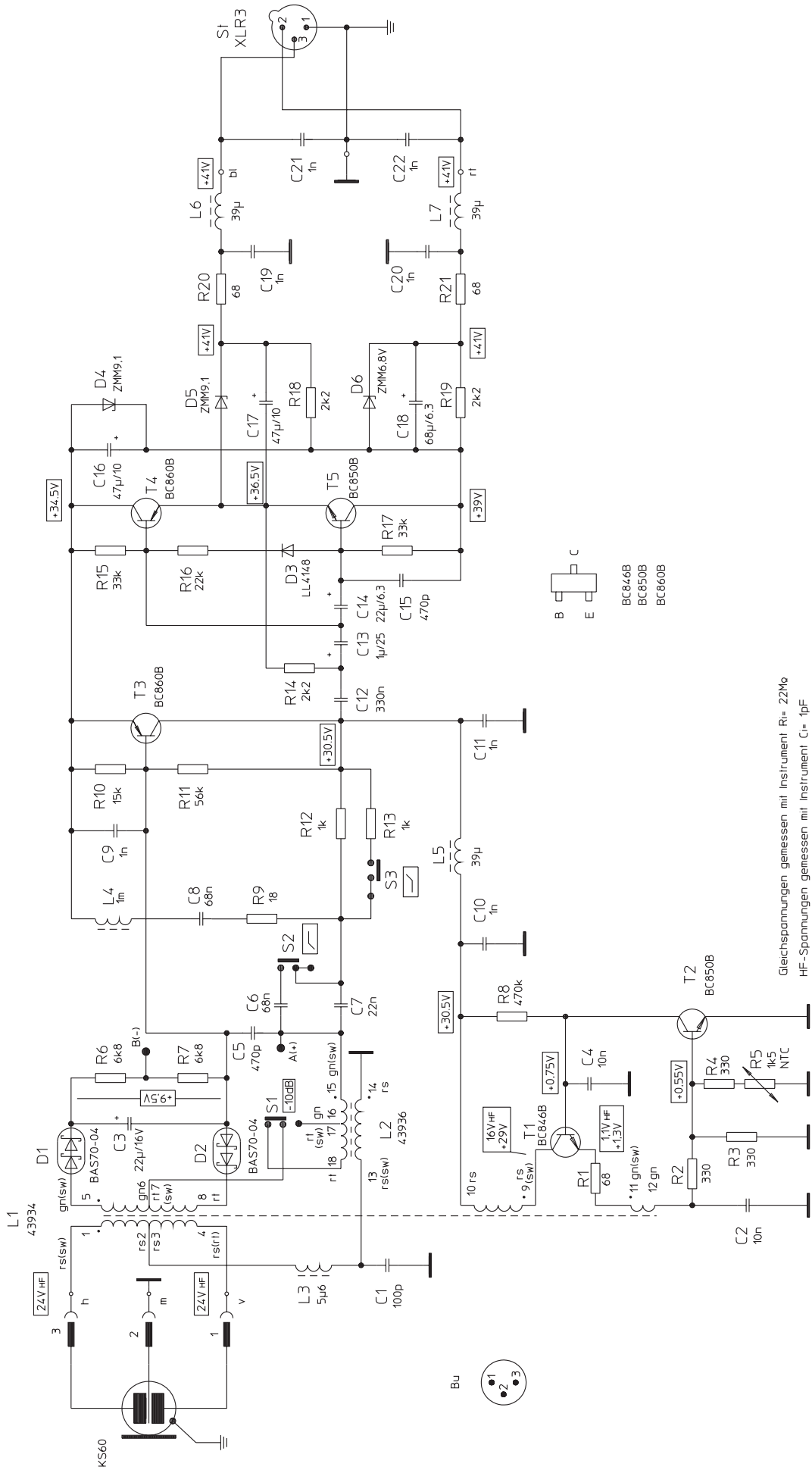

MKH 60, circuit diagram

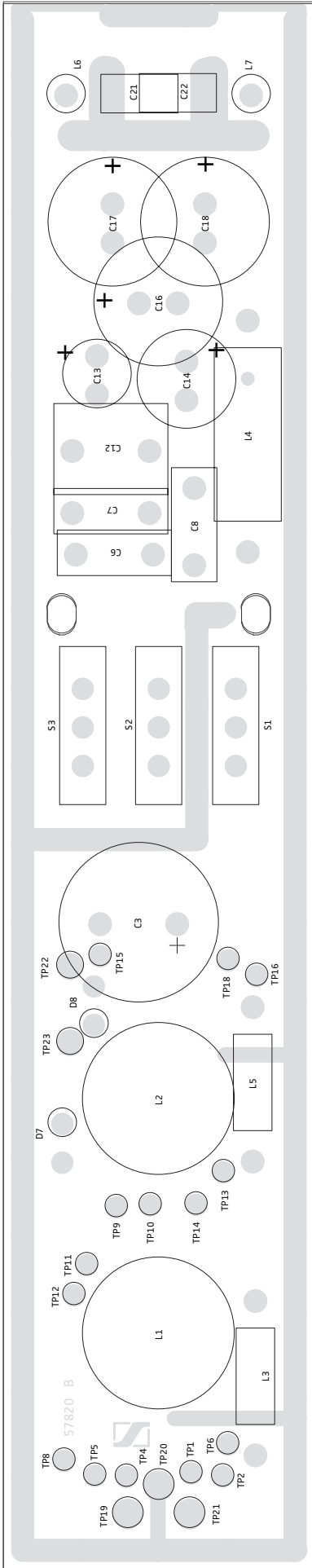

Date : 21.02.2005
 Time : 14:42

MKH 60, component side, new

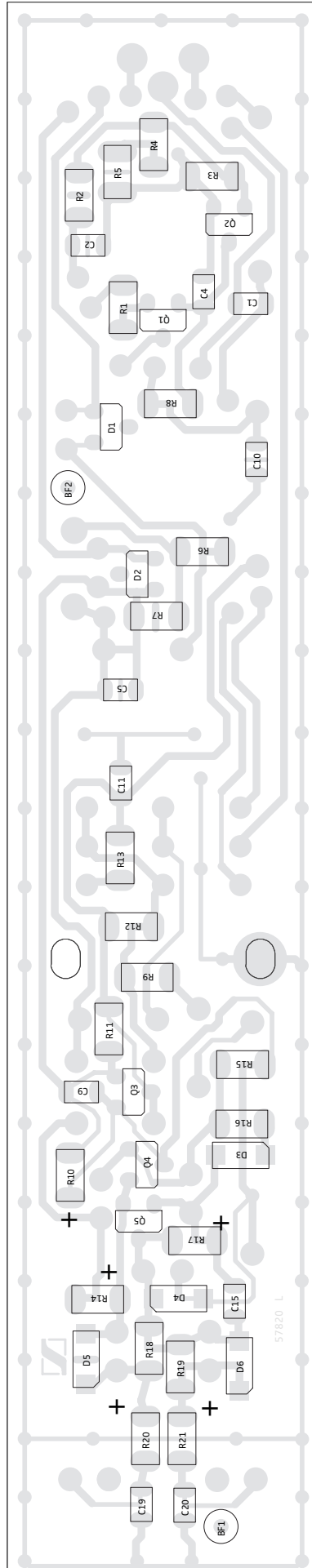

Date : 15.02.2005
 Time : 09:46

MKH 60, solder side, new

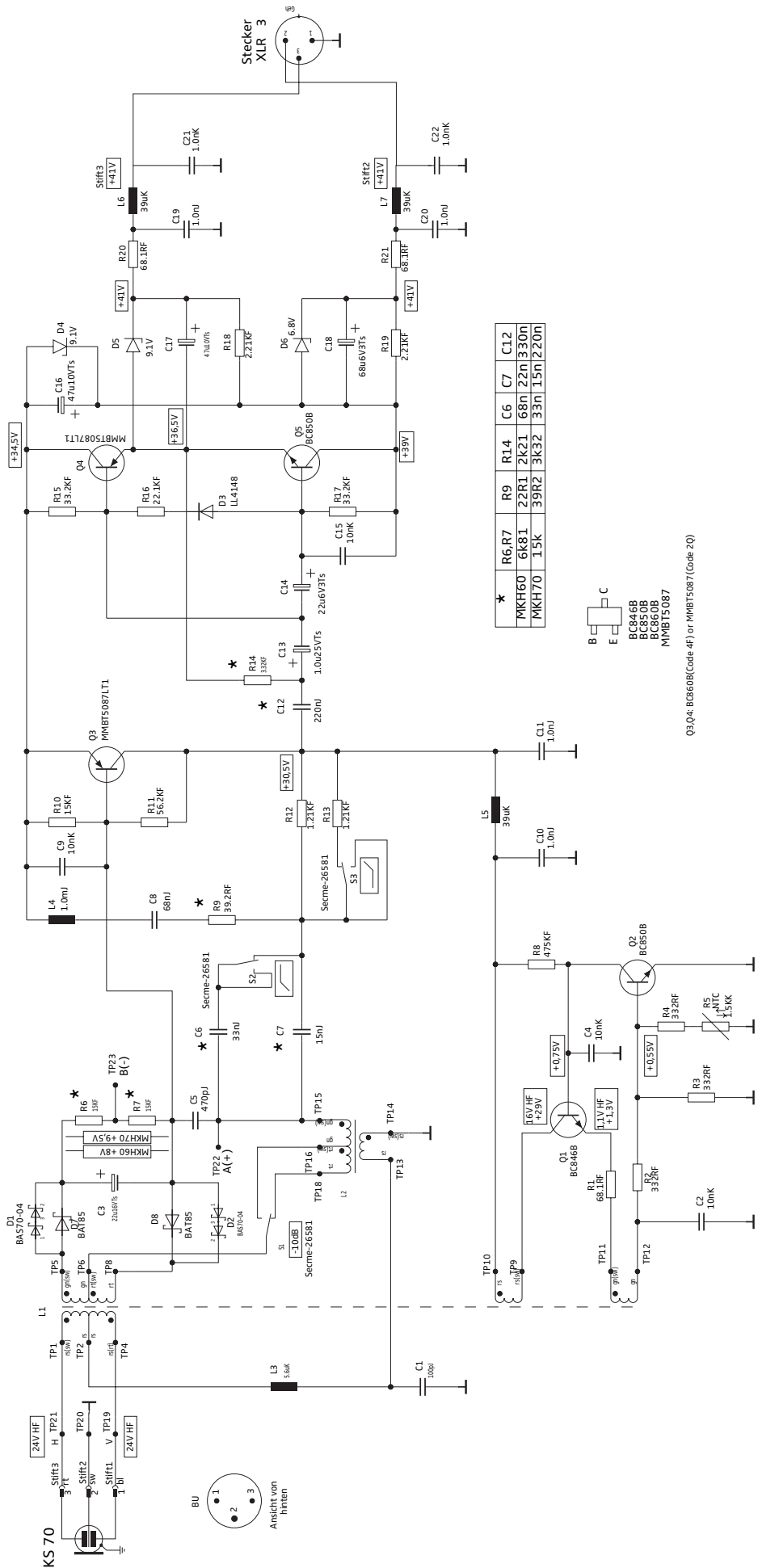

030305kre0900 MKH 60/70

Gleichspannungen gemessen mit Instrument Ri=2,2MΩ
HF-Spannungen gemessen mit Instrument Ci=1pF

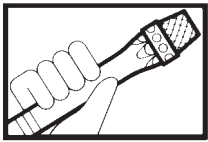

MKH 70-1 P 48

Brief description

The MKH 70-1 P 48 is a high-frequency condenser microphone with hyper-cardioid/lobe characteristic.

Features

- Low noise for highly dynamical recordings
- Uniform directional characteristic
- Broad transmission range
- Switchable pre-attenuation (-10dB)
- Switchable filters (roll-off and presence)

Subject to alteration

Controls

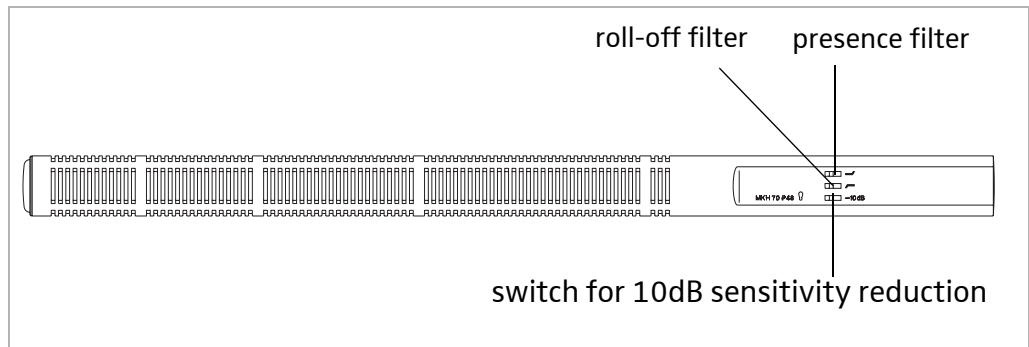

Technical Data

The values in parentheses apply to activated pre-attenuation (-10dB)

| | | |
|--|-------------------|---|
| Acoustic principle | _____ | Pressure gradient/ interference receiver |
| Directional characteristic | _____ | hyper-cardioid/lobe |
| Transmission range | _____ | 50 to 20000Hz |
| Free-field no-load transmission factor at 1kHz | 50mV/Pa (15mV/Pa) | _____ = -28dBV (-38dBV) |
| Equivalent sound pressure level according to DIN 45500, curve A | _____ | 8dB (15dB) |
| Equivalent sound pressure level according to DIN 45405/CCIR 468 | _____ | 20dB (26dB) |
| Overload sound pressure level at 1kHz | _____ | 123dB (133dB) |
| Output | _____ | balanced, transformer-free |
| Electrical impedance at 1kHz | _____ | 150Ω |
| Min. terminating impedance | _____ | 1000Ω |
| Pre-attenuation | _____ | 10dB, switchable |
| Low-cut filter (cut-off) | _____ | 18dB/oct below 50Hz |
| Roll-off filter | _____ | additional 3dB reduction at 70Hz |
| Presence filter | _____ | 5dB emphasis at 10kHz |
| Plug-in connection | _____ | XLR3 |
| Connector layout | _____ | 1: -, housing 2: +, AF+ 3: +, AF- |
| Power supply | _____ | Phantom supply 48V |
| Supply voltage | _____ | 48V ±4V |
| Supply current | _____ | 2mA |
| Dimensions (in mm) | _____ | 25 Ø x 410 |
| Weight | _____ | approx. 180g |
| Scope of delivery | _____ | 1 microphone MKH 70-1 P 48 |

Frequency response

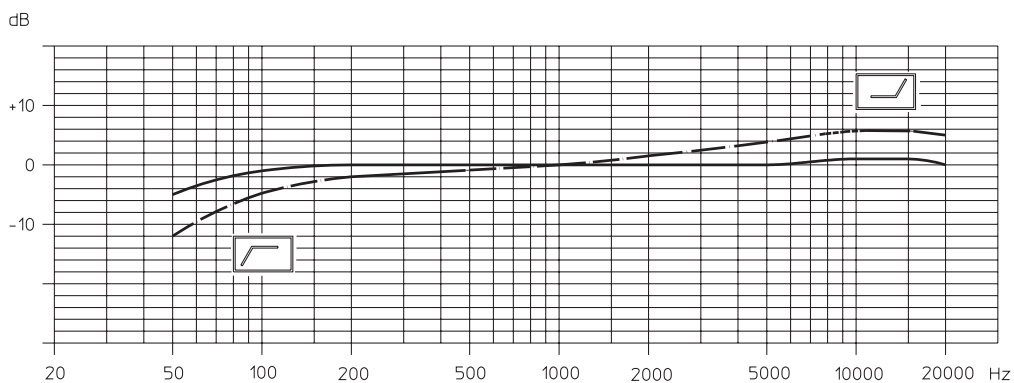

Equalization

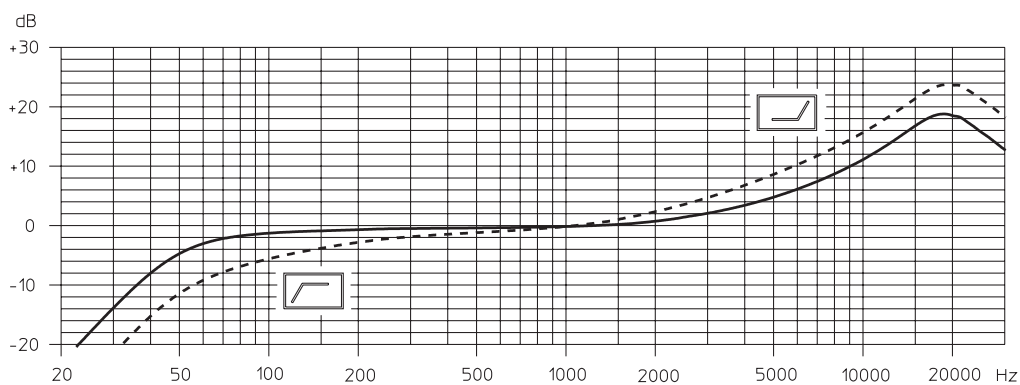

Polar diagram

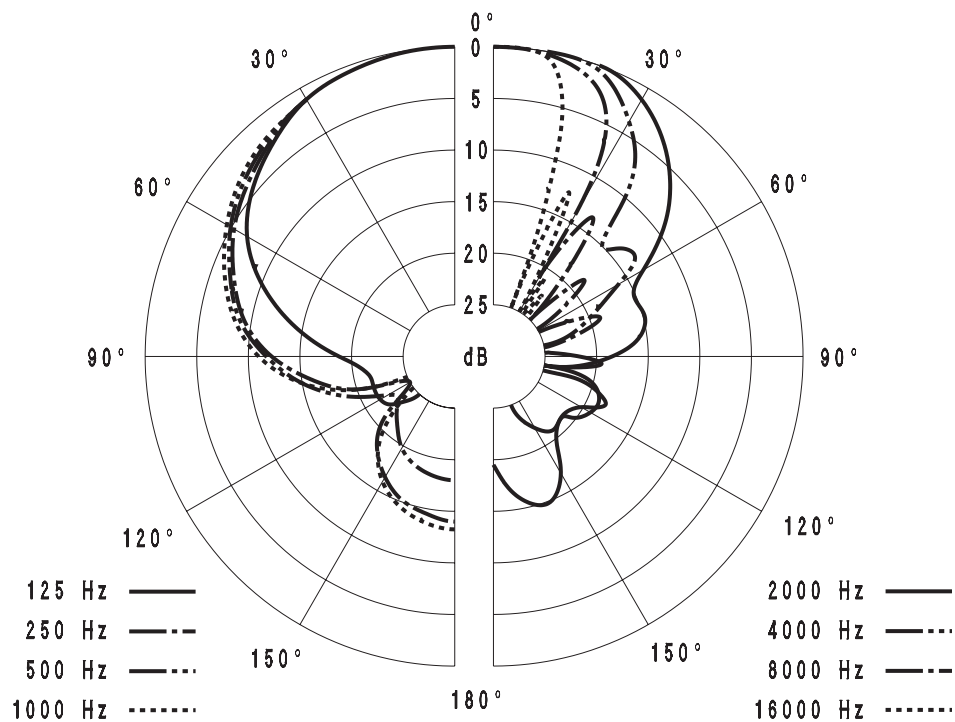

Exploded view

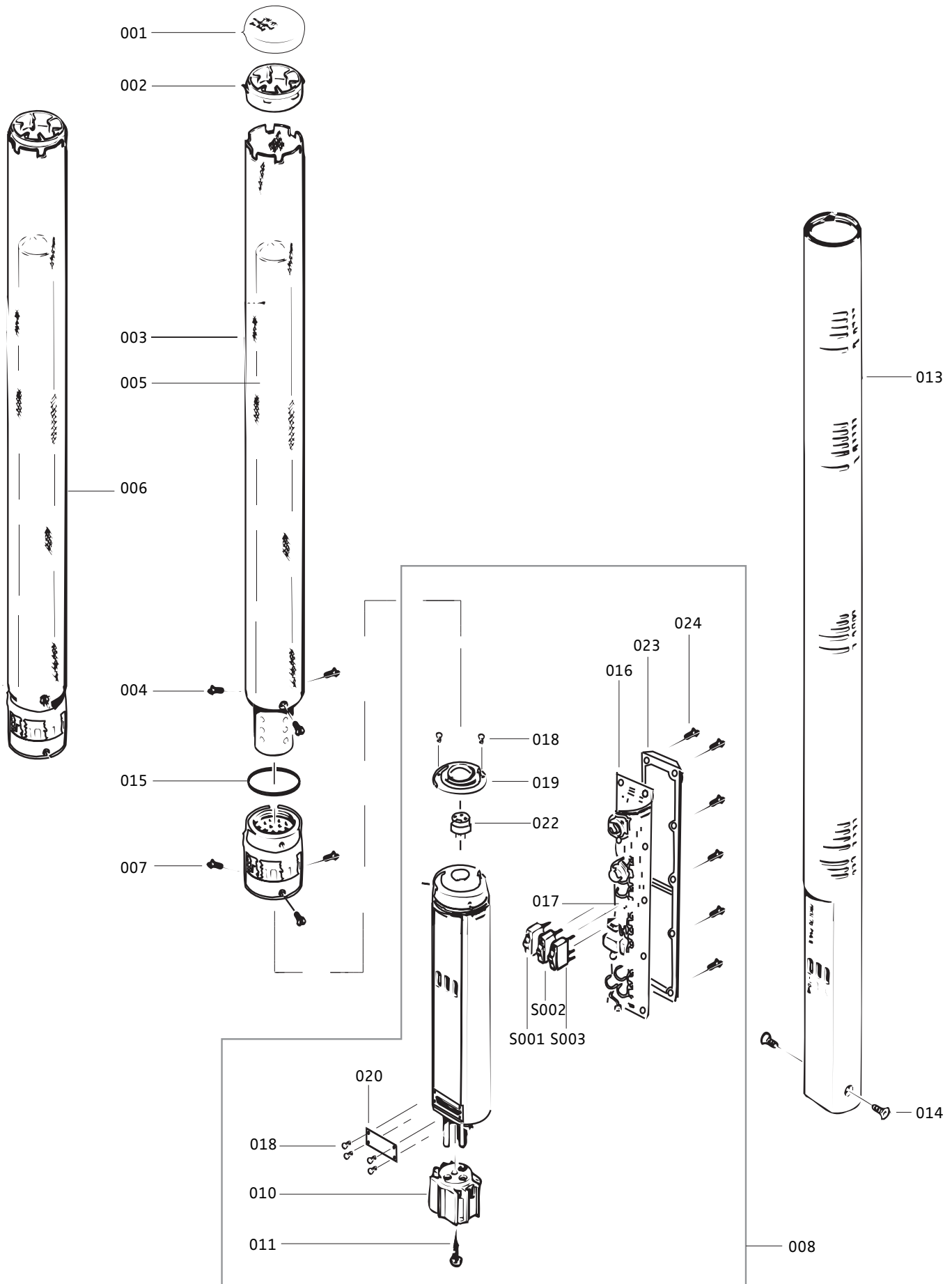

| Pos | Designation |
|------------|--|
| 001 | Sound inlet MKH60/70 |
| 002 | Ring |
| 003 | Gauze tube MKH70 |
| 004 | Countersunk screw M1.4x3 DIN 963 |
| 005 | Tube complete |
| 006 | Condenser capsule complete with gauze tube |
| 007 | Countersunk screw M2x3 |
| 008 | Chassis with PCB MKH70-1 |
| 009 | Brace |
| 010 | Connecting shell for XLR3 |
| 011 | Cheese head screw M2x5 |
| 012 | Type plate MKH70-1 |
| 013 | Housing MKH70 |
| 014 | Countersunk screw hexagon socket M2.5x4 |
| 015 | O ring 18x1 |
| 016 | Printed circuit board assy MKH70 |
| 017 | Base for IC |
| 018 | Cheese head screw M1.7x3 |
| 019 | Ring |
| 020 | Sheet metal 16.8x11.4 |
| 021 | Type plate (frequency as order) |
| 022 | Socket contact with rubber ring |
| 023 | Cover 103.4x19.5x3.6 |
| 024 | Cheese head screw M1.7x6 |
| S001 | Slide switch |
| S002 | Slide switch |
| S003 | Slide switch |

Schematic representations

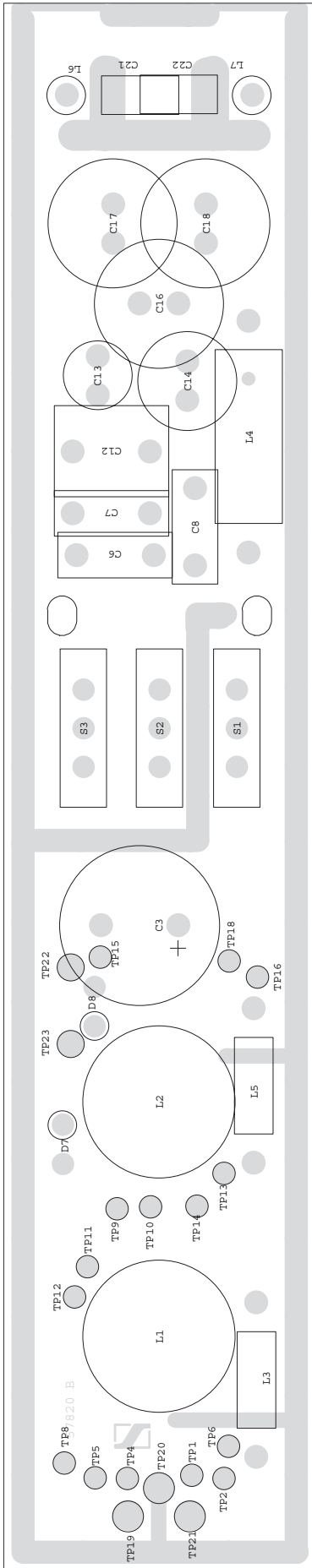

MKH 70, component side

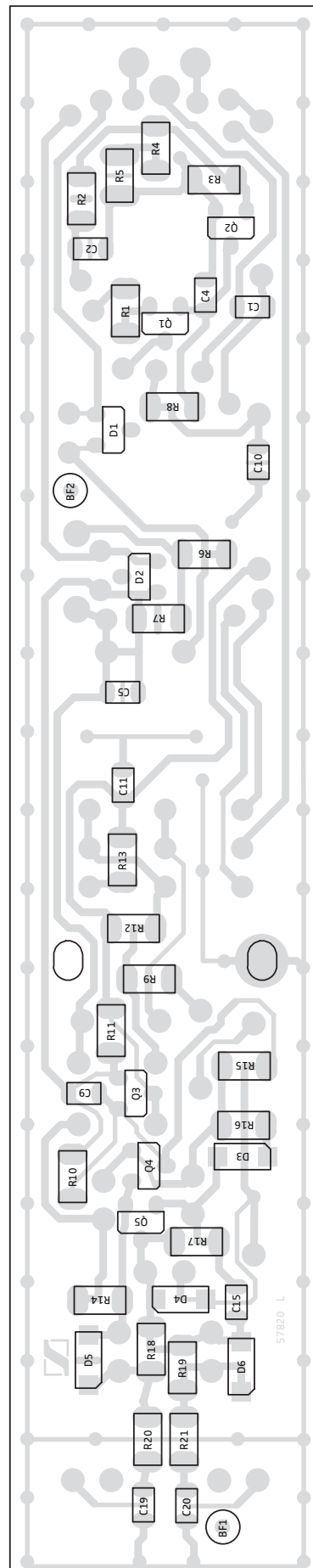

MKH 70, solder side

| | | | | | | | | | | | | | | | | | | | | | | | |
|---|---|---|---|---|---|---|---|---|---|----|----|----|----|----|----|----|----|----|----|----|----|----|---|
| R | 1 | 2 | 3 | 4 | 5 | 6 | 7 | 8 | 9 | 10 | 11 | 12 | 13 | 14 | 15 | 16 | 17 | 18 | 19 | 20 | 21 | 22 | R |
| C | 1 | 2 | 3 | 4 | 5 | 6 | 7 | 8 | 9 | 10 | 11 | 12 | 13 | 14 | 15 | 16 | 17 | 18 | 19 | 20 | 21 | 22 | C |

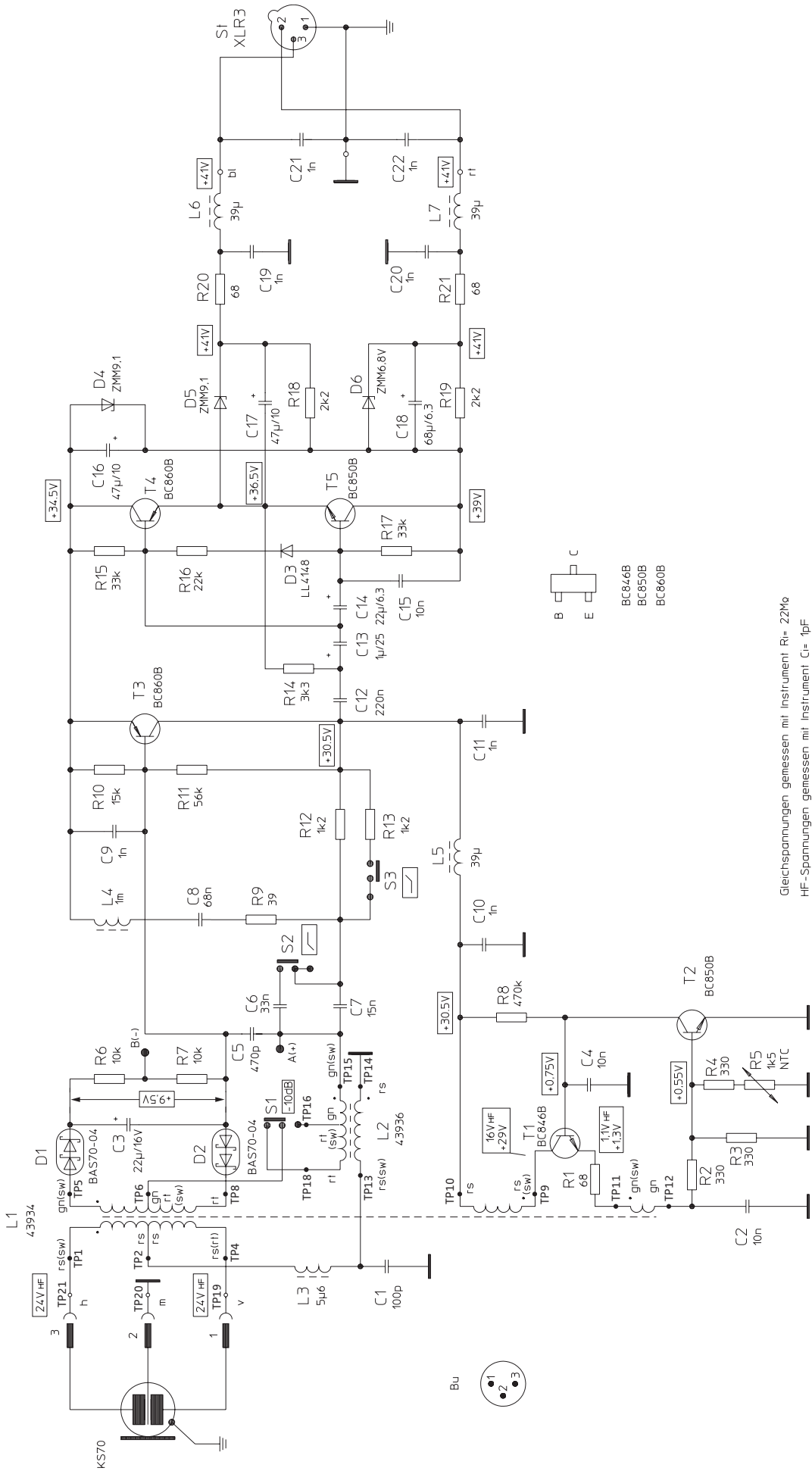

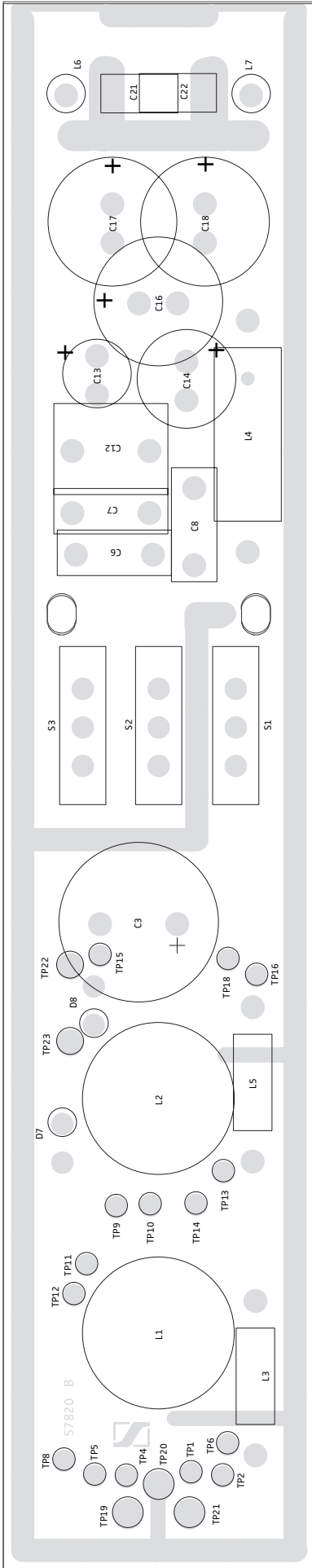

Date : 21.02.2005
 Time : 14:42

MKH 70, component side, new

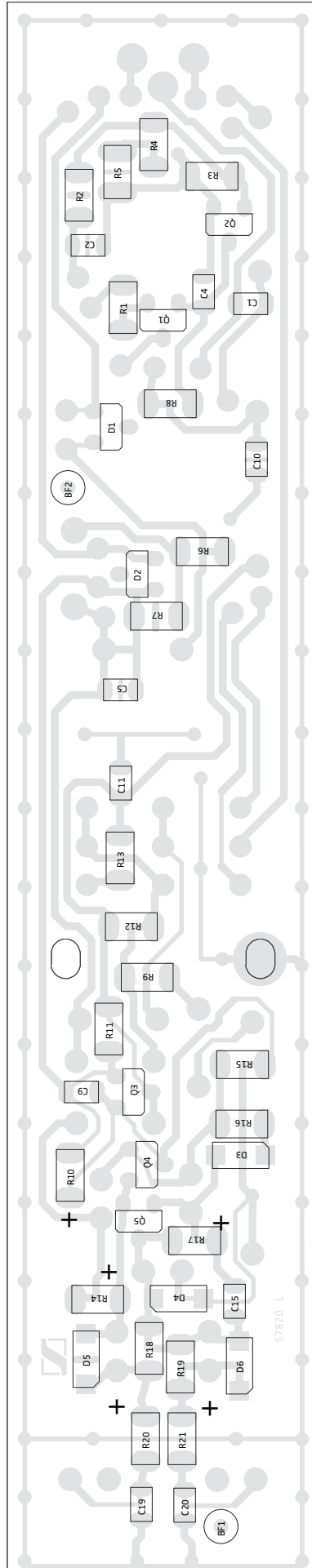

Date : 15.02.2005
 Time : 09:46

MKH 70, solder side, new

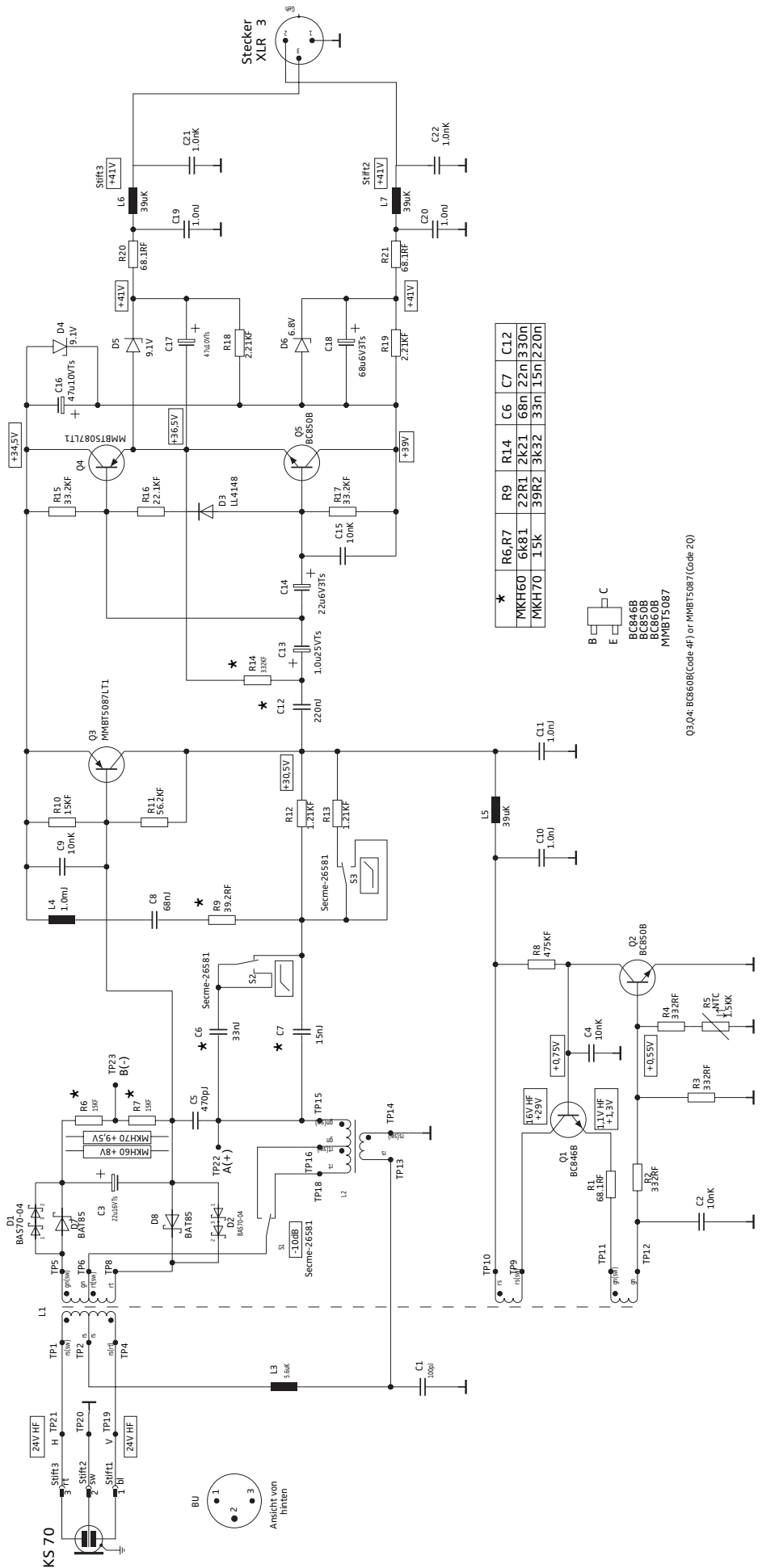

030305kre0900 MKH 60/70

Gleichspannungen gemessen mit Instrument Ri=2,2MΩ
HF-Spannungen gemessen mit Instrument Ci=1pF