

# SERVICE MANUAL

## AM-7040

### STEREO POWER AMPLIFIER

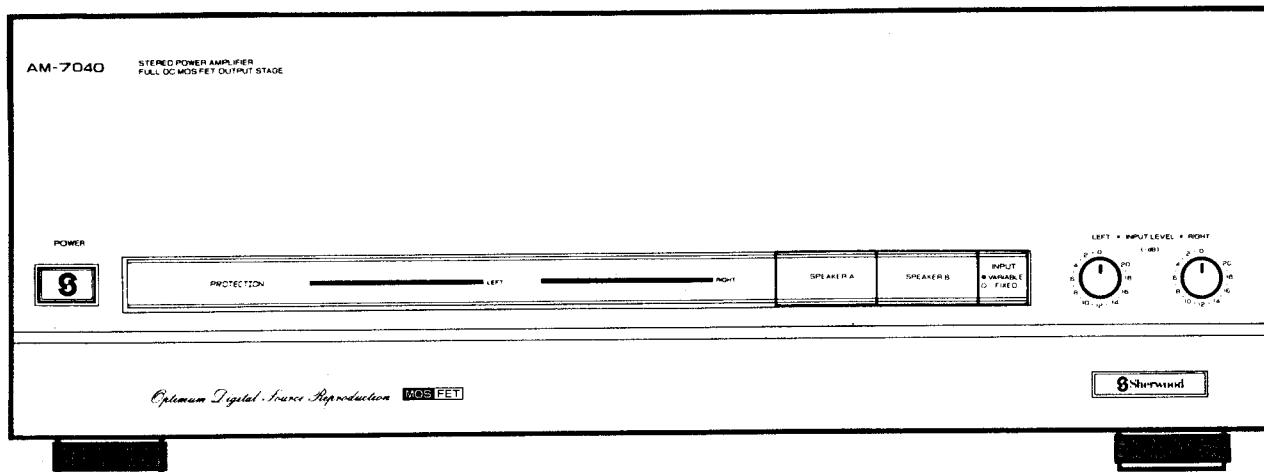

#### CONTENTS

To Service Personnel .....	2	Mechanical Parts List.....	14
Specifications.....	3	Exploded View of Cabinet & Chassis.....	15
Electrical Parts List.....	4	Point to Point Wiring Diagram ( I - II - III ).....	17
Top & Bottom View of P.C Boards.....	7	Schematic Diagram.....	Separate Sheet
Block Diagram.....	13		

#### NOTICE

- This manual is for authorized and qualified service personnel, so the basic service procedure and commonsense of safety are not described in this manual.
- Sherwood always makes every endeavor to improve the products, therefore the specifications and data provided are subject to change without notice.



# To Service Personnel

## 1. Critical Components Information.

The  $\triangle$  marked components on schematic diagram and parts list be replaced with the parts having specifications equal to these originally installed.

## 2. Leakage Current Measurement(For 120V Version only).

When the service has been completed, make sure that all exposed conductive surfaces are properly insulated from the power supply circuits.

- Leakage current meter should have an input impedance of 1500 ohms resistive shunted by 0.15 $\mu$ F capacitor.
- Leakage current shall not be exceed 0.5mA.

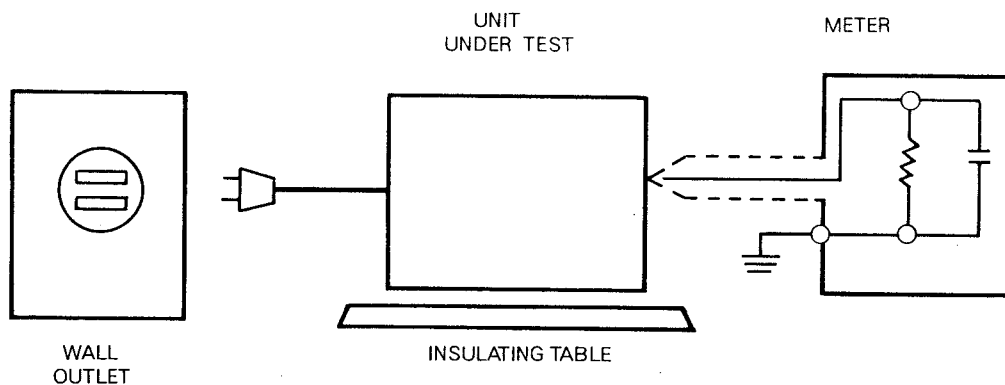

3. Turn the unit OFF, and disconnect the power supply cord during disassembly and replacement of parts.

4. When the service has been completed, be sure to check all protective device and spacings before returning the unit to customer.

5.  This symbol is intended to alert the user to the presence of uninsulated “dangerous voltage” with in the product’s enclosure that may be of sufficient magnitude to constitute a risk of electric shock hazard to persons.

6.  This symbol is intended to alert the user to the presence of important operating and maintenance(servicing) instructions in the literature accompanying the appliance.

7. Caution: To prevent electric shock do not use this(polarized) plug with an extension cord, receptacle or other outlet unless the blades can be fully inserted to prevent blade exposure.

# Specifications

## IHF/EIA Version

Power Output per Channel, Minimum RMS 20-20 kHz (FTC Power)	
no more than 0.04% THD, into 8 ohms	200W
no more than 0.08% THD, into 4 ohms	320W
Dynamic Power Output per Channel (FTC Power + Dynamic Headroom)	
into 8 ohms	250W
into 4 ohms	450W
into 2 ohms	650W
Intermodulation Distortion into 8 ohms at 200W	0.02%
Damping Factor into 8 ohms at 50 Hz	150
Frequency Response, -3 dB	5 Hz-150 kHz
Signal to Noise Ratio, "A" wtd/unwtd	
at 1kohm 200W Terminated	120/90 dB
at 1kohm 1W Terminated	95/80 dB
Input Sensitivity into 8 ohms, at 1 kHz 200W	1000mV
Channel Separation	
at 1 kHz, 1 kohm Terminated	80 dB
at 70 Hz, 1 kohm Terminated	70 dB

## DIN/IEC Version

Power output per Channel	
IEC Standard, at 63-12,500 Hz into 8 ohms	220W
at 63-12,500 Hz into 4 ohms	340W
DIN Standard, at 1 kHz into 8 ohms	230W
at 1 kHz into 4 ohms	350W
Dynamic Power output per Channel	
into 8 ohms	270W
into 4 ohms	450W
into 2 ohms	650W
Total Harmonic Distortion, -6 dB Rated Output Power	
at 1 kHz into 8 ohms	0.007%
at 10 kHz into 8 ohms	0.009%
Intermodulation Distortion, -6 dB Rated Output Power	
into 8 ohms	0.007%
into 4 ohms	0.008%
Damping Factor at 200W 50 Hz, into 8 ohms	150
Frequency Response, -3 dB	5 Hz-150 kHz
Signal to Noise Ratio, "A" wtd/unwtd (at 22 kohm Terminated, Reference 0 dB)	
at 200W into 8 ohms	110/90 dB
at 1W into 8 ohms	90/80 dB
Input Sensitivity at 200W, 1 kHz into 8 ohms	1000mV
Channel Separation at 200W into 8 ohms	
22 kohms Terminated at 1 kHz	80 dB
22 kohms Terminated at 10 kHz	70 dB

## General Specifications

Power Consumption	
IHF/EIA Version	450W Max (Vol Min 60W)
DIN/IEC Version	1300W Max
Slew Rate	40V/μs
Rising Time	2.0μsec
Dimensions	(W)440×(H)150×(D)400mm (W)17.3×(H)5.9×(D)15.7inch
Weight	22.5 Kg (56.1 lbs)

Power Requirements	
A USA/CANADIAN Model	120VAC/60 Hz
B MULTI-VOLTAGE MODEL	120/220VAC, 60/50 Hz
C General EUROPEAN MODEL	220VAC/50 Hz
D West GERMAN & ITALIAN MODEL	220VAC/50 Hz
E BRITISH & AUSTRALIAN MODEL	240VAC/50 Hz
F SWISS & SCANDINAVIAN MODEL	220VAC/50 Hz

Note: Specifications and Design subject to change without notice for improvements.

# Electrical Parts List

FRONT BOARD 4002118700

Ref. No	Parts No.	Description	Position	Remark
<b>• Capacitors</b>				
C109L/R	3479210061	Electrolytic 10 $\mu$ F/35V	A/J	
C110L/R	3479210061	Electrolytic 10 $\mu$ F/35V	A/J	
C111L/R	3579101130	Ceramic 100pF/50V	A/J	
C112L/R	3479247041	Electrolytic 47 $\mu$ F/25V	A/J	
C113L/R	3579473530	Ceramic 0.047 $\mu$ F/50V	B/I	
C114L/R	3579473530	Ceramic 0.047 $\mu$ F/50V	B/I	
C117L/R	3579102530	Ceramic 0.001 $\mu$ F/50V	A/J	
C118L/R	3579102530	Ceramic 0.001 $\mu$ F/50V	A/J	
C121L/R	3509100050	Ceramic 10pF/500V	B/I	
C122L/R	3509100050	Ceramic 10pF/500V	B/I	
C125L/R	3579473530	Ceramic 0.047 $\mu$ F/50V	C/H	
C126L/R	3579473530	Ceramic 0.047 $\mu$ F/50V	C/H	
C129L/R	3409222141	Electrolytic 220 $\mu$ F/25V	B/I	
C130L/R	3409222141	Electrolytic 220 $\mu$ F/25V	B/I	
C131L/R	3509103450	Ceramic 0.01 $\mu$ F/500V	D/G	
C132L/R	3509103450	Ceramic 0.01 $\mu$ F/500V	D/G	
C133L/R	3509150050	Ceramic 15pF/500V	C/I	
C139L/R	3579473530	Ceramic 0.047 $\mu$ F/50V	C/I	
C404L/R	3479247871	Electrolytic 0.047 $\mu$ F/50V	C/E	
C405L/R	3479222041	Electrolytic 22 $\mu$ F/25V	B/D	
C406L/R	3479222041	Electrolytic 22 $\mu$ F/25V	C/E	
C509	3479247041	Electrolytic 47 $\mu$ F/25V	F	
C510	3479247041	Electrolytic 47 $\mu$ F/25V	E	
<b>• Diodes</b>				
D101L/R	2058306101	1N4148	A/J	
D102L/R	2058306101	1N4148	A/J	
D103L/R	2058599100	Zener, DZ3.3BM	B/I	
D104L/R	2058599100	Zener, DZ3.3BM	B/I	
D105L/R	2058599100	Zener, DZ3.3BM	C/H	
D106L/R	2058599100	Zener, DZ3.3BM	C/H	
D107L/R	2058306101	1N4148	C/H	
D403L/R	2058306101	1N4148	C/E	
<b>• ICs</b>				
IC402L/R	2168000114	MC 4558	B/D	
△ IC501	2168601106	Regulador 7818	F	
△ IC502	2168600106	Regulador 7818	E	
<b>• LEDs</b>				
L301	2308220507	SLV 56DC3, Amber	F	
L302	2308220507	SLV 56DC3, Amber	G	
L303	2308220507	SLV 56DC3, Amber	G	
L304	2308220507	SLV 56DC3, Amber	H	
L305	2308220507	SLV 56DC3, Amber	A	
L306	2308220507	SLV 56DC3, Amber	B	
L308	2308220507	SLV 56DC3, Amber	H	
DISPLAY 1	2318271003	Display ALD450RA	C	
DISPLAY 2	2318271003	Display ALD450RA	E	
<b>• Resistors</b>				
R109L/R	3069473270	Metal Film 47Kohm 1/4W J	A/J	
R110L/R	3069102270	Metal Film 1Kohm 1/4W J	A/J	
R111L/R	3069473270	Metal Film 47Kohm 1/4W J	A/J	
R112L/R	3069473270	Metal Film 47Kohm 1/4W J	A/J	
R113L/R	3069102270	Metal Film 1Kohm 1/4W J	A/J	
R114L/R	3069102270	Metal Film 1Kohm 1/4W J	A/J	
R115 L/R	3069102270	Metal Film 1Kohm 1/4W J	A/J	
R116 L/R	3069102270	Metal Film 1Kohm 1/4W J	A/J	
R117 L/R	3069102270	Metal Film 1Kohm 1/4W J	B/I	
R118 L/R	3069102270	Metal Film 1Kohm 1/4W J	B/I	
R119 L/R	3069122270	Metal Film 1.2Kohm 1/4W J	B/I	
R120 L/R	3069122270	Metal Film 1.2Kohm 1/4W J	B/I	
R121 L/R	3069101270	Metal Film 100 ohm 1/4W J	B/J	
R122 L/R	3069101270	Metal Film 100 ohm 1/4W J	B/J	
R123 L/R	3069101270	Metal Film 100 ohm 1/4W J	B/I	
R124 L/R	3069101270	Metal Film 100 ohm 1/4W J	B/I	
R125L/R	3069222270	Metal Film 2.2Kohm 1/4W J	A/J	
R126L/R	3069222270	Metal Film 2.2Kohm 1/4W J	A/J	
R127L/R	3069222270	Metal Film 2.2Kohm 1/4W J	B/I	

Ref. No	Parts No.	Description	Position	Remark
R128L/R	3069222270	Metal Film 2.2Kohm 1/4W J	B/I	
R129L/R	3069102270	Metal Film 1Kohm 1/4W J	B/I	
R130L/R	3069102270	Metal Film 1Kohm 1/4W J	B/I	
R131L/R	3069123270	Metal Film 12Kohm 1/4W J	B/I	
R132L/R	3069123270	Metal Film 12Kohm 1/4W J	B/I	
R133L/R	3069472270	Metal Film 4.7Kohm 1/4W J	B/I	
R134L/R	3069472270	Metal Film 4.7Kohm 1/4W J	B/I	
R135	3069102270	Metal Film 1Kohm 1/4W J	A/J	
R136L/R	3069224270	Metal Film 220Kohm 1/4W J	D/H	
R137L/R	3069101270	Metal Film 100 ohm 1/4W J	B/I	
R138L/R	3069101270	Metal Film 100 ohm 1/4W J	B/I	
R139L/R	3069479270	Metal Film 4.7 ohm 1/4W J	C/H	
R140L/R	3069479270	Metal Film 4.7 ohm 1/4W J	C/H	
R141L/R	3069561270	Metal Film 560 ohm 1/4W J	B/I	
R142	3069102270	Metal Film 1Kohm 1/4W J	A/J	
R143L/R	3069273270	Metal Film 27Kohm 1/4W J	A/J	
R147	3069681270	Metal Film 680 ohm 1/4W J	C/I	
R221L/R	3069101270	Metal Film 100 ohm 1/4W J	G	
R222L/R	3069101270	Metal Film 100 ohm 1/4W J	C/H	
R317	3069561270	Metal Film 560 ohm 1/4W J	G	
R318	3069561270	Metal Film 560 ohm 1/4W J	G	
R380	3069102270	Metal Film 1Kohm 1/4W J	A	
R407L/R	3069333270	Metal Film 33Kohm 1/4W J	C/E	
R408L/R	3069333270	Metal Film 33Kohm 1/4W J	C/E	
R409L/R	3069104270	Metal Film 100Kohm 1/4W J	C/E	
R410L/R	3069153270	Metal Film 15Kohm 1/4W J	B/D	
R411L/R	3069224270	Metal Film 220Kohm 1/4W J	B/D	
R412L/R	3069102270	Metal Film 1Kohm 1/4W J	B/D	
R413L/R	3069102270	Metal Film 1Kohm 1/4W J	B/D	
R414L/R	3069104270	Metal Film 100Kohm 1/4W J	B/D	
R415L/R	3069821270	Metal Film 820 ohm 1/4W J	B/D	
R416L/R	3069101270	Metal Film 100 ohm 1/4W J	B/D	
R417L/R	3069101270	Metal Film 100 ohm 1/4W J	B/D	
<b>• Transistors</b>				
Q101L/R	2008213109	NPN $\mu$ PA 74HA	B/I	
Q102L/R	2008613115	PNP $\mu$ PA 75HA	B/I	
Q103L/R	2208606108	NPN KTC 2240BL	B/J	
Q104L/R	2008206104	PNP KTC 970BL	B/J	
Q105L/R	2208606108	NPN KTC 2240BL	B/I	
Q106L/R	2008206104	PNP KTC 970BL	B/I	
Q107L/R	2208606108	NPN KTC 2240BL	B/J	
Q108L/R	2008206104	PNP KTC 970BL	B/J	
Q109L/R	2018206109	FET 2SK30A	B/I	
Q110L/R	2018206109	FET 2SK30A	B/I	
Q111L/R	2008206104	PNP KTA 970BL	B/I	
Q112L/R	2208606108	NPN KTC 2240BL	B/I	
Q113L/R	2028116106	PNP 2SA 958	C/H	
Q114L/R	2028416109	NPN 2SC2168	C/H	

**POWER - A BOARD 4002118500**

Ref. No	Parts No.	Description	Position	Remark
<b>• Capacitor</b>				
C201	3409210991	Electrolytic 1 $\mu$ F/100V		
<b>• Diode</b>				
D201	2058106101	Rectifier 1N4003		
<b>• Resistors</b>				
R203	3039681472	Metal Oxide 680 ohm 1W		
R205	3039681472	Metal Oxide 680 ohm 1W		
R207	3039681472	Metal Oxide 680 ohm 1W		
R209	3039681472	Metal Oxide 680 ohm 1W		
R211	3059278682	Cement 0.27 ohm 3W		
R213	3059278682	Cement 0.27 ohm 3W		
R215	3059278682	Cement 0.27 ohm 3W		
R216	3059278682	Cement 0.27 ohm 3W		
R223	3069100472	Metal Oxide 10 ohm 1W		
R225	3039100472	Metal Oxide 10 ohm 1W		
R227	3039100472	Metal Oxide 10 ohm 1W		
R229	3039100472	Metal Oxide 10 ohm 1W		
<b>• Transistors</b>				
Q203	2028811101	MOS-FET 2SK1058		
Q205	2028811101	MOS-FET 2SK1058		
Q207	2028811101	MOS-FET 2SK1058		
Q209	2028811101	MOS-FET 2SK1058		

**INPUT BOARD 4002118650**

Ref. No	Parts No.	Description	Position	Remark
<b>• Capacitors</b>				
C101L/R	3579101130	Ceramic 100pF/50V		
C102L/R	3579101130	Ceramic 100pF/50V		
C103L/R	3579101130	Ceramic 100pF/50V		
C104L/R	3579101130	Ceramic 100pF/50V		
C105L/R	3579101130	Ceramic 330pF/50V		
C106L/R	3579101130	Ceramic 330pF/50V		
C107L/R	3479247041	Electrolytic 47 $\mu$ F/25V		
C108L/R	3479247041	Electrolytic 47 $\mu$ F/25V		
C151L/R	3479247971	Electrolytic 4.7 $\mu$ F/50V		
C152L/R	3479247971	Electrolytic 4.7 $\mu$ F/50V		
<b>• IC</b>				
IC10 L/R	2168020106	NJM 2068		
<b>• Resistors</b>				
R101L/R	3069121270	Metal Film 120 ohm 1/4W J		
R102L/R	3069272270	Metal Film 2.7Kohm 1/4W J		
R103L/R	3069473270	Metal Film 47 Kohm 1/4W J		
R104L/R	3069101270	Metal Film 100 ohm 1/4W J		
R105L/R	3069101270	Metal Film 100 ohm 1/4W J		
R106L/R	3069121270	Metal Film 120 ohm 1/4W J		
R107L/R	3069272270	Metal Film 2.7Kohm 1/4W J		
R108L/R	3069473270	Metal Film 47 Kohm 1/4W J		
R161L/R	3069471270	Metal Film 470 ohm 1/4W J		
R162L/R	3069104270	Metal Film 100 Kohm 1/4W J		
R163L/R	3069471270	Metal Film 470 ohm 1/4W J		
R164L/R	3069104270	Metal Film 100 Kohm 1/4W J		

**POWER - B BOARD 4002118510**

Ref. No	Parts No.	Description	Position	Remark
<b>• Capacitor</b>				
C202	3409210991	Electrolytic 1 $\mu$ F/100V		
<b>• Diode</b>				
D202	2058106101	Rectifier 1N4003		
<b>• Resistors</b>				
R204	3039221472	Metal Oxide 220 ohm 1W		
R206	3039221472	Metal Oxide 220 ohm 1W		
R208	3039221472	Metal Oxide 220 ohm 1W		
R210	3039221472	Metal Oxide 220 ohm 1W		
R212	3059278682	Cement 0.27 ohm 3W		
R214	3059278682	Cement 0.27 ohm 3W		
R216	3059278682	Cement 0.27 ohm 3W		
R218	3059278682	Cement 0.27 ohm 3W		
R224	3069100472	Metal Oxide 10 ohm 1W		
R226	3039100472	Metal Oxide 10 ohm 1W		
R228	3039100472	Metal Oxide 10 ohm 1W		
R230	3039100472	Metal Oxide 10 ohm 1W		
<b>• Transistors</b>				
Q204	2028611101	MOS-FET 2SJ162		
Q206	2028611101	MOS-FET 2SJ162		
Q208	2028611101	MOS-FET 2SJ162		
Q210	2028611101	MOS-FET 2SJ162		

**FUSE BOARD 4002118660**

Ref. No	Parts No.	Description	Position	Remark
<b>• Capacitors</b>				
△ C512	3549472407	Ceramic 0.0047 $\mu$ F 400V AC		
△ C512	3509103450	Ceramic 0.0047 $\mu$ F 400V AC		D
<b>• Diode</b>				
△ D501L/R	2058113131	Rectifier, MB254		
<b>• Fuse</b>				
△ F506L/R	5508113230	SB 4A 250V AC, 31.8mm		B, KS
<b>• Power Transformers</b>				
	2828060111	L-CH		A
	2828060101	R-CH		A
	2828060217	L-CH		C, F
	2828060207	R-CH		C, F
	2828065017	L-CH		D
	2828065007	R-CH		D
	2828060411	L-CH		KS
	2828060401	R-CH		KS
	2828060317	L-CH		E
	2828060307	R-CH		E
	4678600110	Reseting Thermal Protector T135 ARIUI		Thermal Protector

**SPEAKER - A BOARD 4002118600**

Ref. No	Parts No.	Description	Position	Remark
<b>• Capacitors</b>				
C301L/R	3409247871	Electrolytic 0.047μF 50V		
C302	3409247971	Electrolytic 4.7μF 50V		
C303	3408247111	Electrolytic 470μF 6.3V		
C304	3409210131	Electrolytic 100μF 16V		
C309L/R	3609223180	Metallized Poly 0.022μF 630V		
<b>• Diodes</b>				
D301L/R	2058306101	1N4148		
D302L/R	2058306101	1N4148		
D303	2058106101	1N4003, Rectifier		
D304	2058599116	DZ-12BM, Zener		
D305	2058106101	1N4003, Rectifier		
D306	2058106101	1N4003, Rectifier		
RLY1	5528001470	HL2-HP-DC24V, Relay		
RLY2	5528001470	HL2-HP-DC24V, Relay		
L301L/R	2468001010	0.5μH, Inductor		
L302L/R	2468001010	0.5μH, Inductor		
<b>• Resistors</b>				
R301L/R	3069332270	Metal Film 3.3Kohm 1/4W J		
R302L/R	3069273270	Metal Film 27Kohm 1/4W J		
R303	3069102270	Metal Film 1Kohm 1/4W J		
R304	3069474270	Metal Film 470Kohm 1/4W J		
R306	3069103270	Metal Film 10Kohm 1/4W J		
R307	3069273270	Metal Film 27Kohm 1/4W J		
R308	3069101270	Metal Film 100ohm 1/4W J		
R309	3069104270	Metal Film 100Kohm 1/4W J		
R310	3069333270	Metal Film 33Kohm 1/4W J		
R311	3069103270	Metal Film 10Kohm 1/4W J		
R312	3069103270	Metal Film 10Kohm 1/4W J		
R313	3069333270	Metal Film 33Kohm 1/4W J		
R314	3069681270	Metal Film 680ohm 1/4W J		
R315L/R	3069183270	Metal Film 18Kohm 1/4W J		
R316	3069561270	Metal Film 560ohm 1/4W J		
R319	3039339472	Metal Oxide 3.3ohm 1W		
R320	3039339472	Metal Oxide 3.3ohm 1W		
R321L/R	3039339472	Metal Oxide 3.3ohm 1W		
R322L/R	3039339472	Metal Oxide 3.3ohm 1W		
R327L/R	3039220572	Cement 22ohm 2W		
R328L/R	3039220572	Cement 22ohm 2W		
R371	3069473270	Metal Film 47ohm 1/4W J		
R374	3039222472	Metal Oxide 2.2kohm 1W J		
R381	3069103270	Metal Film 10Kohm 1/4W J		
<b>• Transistors</b>				
Q301L/R	2008609102	MPSA 06		
Q302	2008209101	MPSA 55		
Q303	2008609102	MPSA 06		
Q304	2008609102	MPSA 06		
Q305	2008609102	MPSA 06		
Q306	2008609102	MPSA 06		
Q307	2008609102	MPSA 06		
Q308	2008609102	MPSA 06		
Q309	2008609102	MPSA 06		
Q310	2008609102	MPSA 06		

**MAIN SUPPLY - A BOARD 4002118620**

Ref. No	Parts No.	Description	Position	Remark
<b>• Capacitors</b>				
C501L/R	3419582210	Electrolytic 8200μF	80V	
C502L/R	3419582210	Electrolytic 8200μF	80V	
C503L/R	3419582210	Electrolytic 8200μF	80V	
C504L/R	3419582210	Electrolytic 8200μF	80V	

**18V REGULATOR BOARD 4002118640**

Ref. No	Parts No.	Description	Position	Remark
<b>• Capacitors</b>				
C505	3409247161	Electrolytic 470μF/35V		
C506	3409247161	Electrolytic 470μF/35V		
C511	3409247041	Electrolytic 47μF/35V		
<b>• Diodes</b>				
△ D502	2058106101	Rectifier 1N4003		
△ D503	2058106101	Rectifier 1N4003		
△ D504	2058106101	Rectifier 1N4003		
△ D505	2058106101	Rectifier 1N4003		
△ D506	2058106101	Rectifier 1N4003		
△ D507	2058106101	Rectifier 1N4003		
<b>• Fuses</b>				
△ F501L/R	5508113336	SB 7A 250V AC, 31.8mm	Rear Panel	A, B
△ F501L/R	5508302934	TL 4A 250V AC 20mm	Rear Panel	C, D, E, F
△ F502L/R	5508113431	SB 10A 250V AC, 31.8mm	Rear Panel	A, B, C, D, E, F
△ F503L/R	5508113431	SB 10A 250V AC, 31.8mm	Rear Panel	A, B, C, D, E, F
△ F504	5508211631	NB0 54A 250V AC, 31.8mm		A, B, KS
△ F504	5508301634	TL 500mV 250V AC, 20mm		C, D, E, F
△ F505	5508211631	NB 0.5A 250V AC, 31.8mm		A, B, KS
△ F505	5508301634	TL 500mV 250V AC, 20mm		C, D, E, F
<b>• Resistors</b>				
R501	3039339472	Metal Oxide 3.3 ohm(1W)		
R502	3039339472	Metal Oxide 3.3 ohm(1W)		
R503	3039222472	Metal oxide 2.2 ohm		

**SPEAKER-B BOARD 4002118610**

Ref. No	Parts No.	Description	Position	Remark
<b>• Capacitors</b>				
C305L/R	3609223180	Metallized Poly 0.022μF/630V		
C306L/R	3609223180	Metallized Poly 0.022μF/630V		
<b>• Resistors</b>				
R323L/R	3039220472	Metal Oxide 22ohm 2W J		
R324L/R	3039220472	Metal Oxide 22ohm 2W J		
R325L/R	3039220472	Metal Oxide 22ohm 2W J		
R326L/R	3039220472	Metal Oxide 22ohm 2W J		

# Top & Bottom View of P.C Boards

MAIN SUPPLY-A BOARD 4002118620

- TOP VIEW

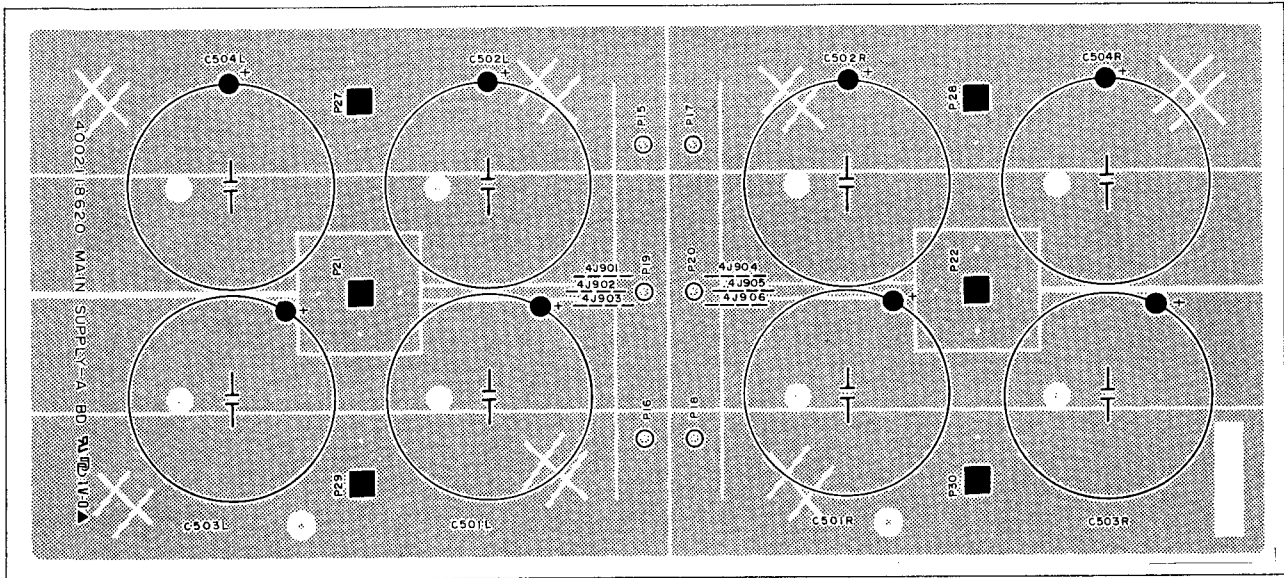

- BOTTOM VIEW

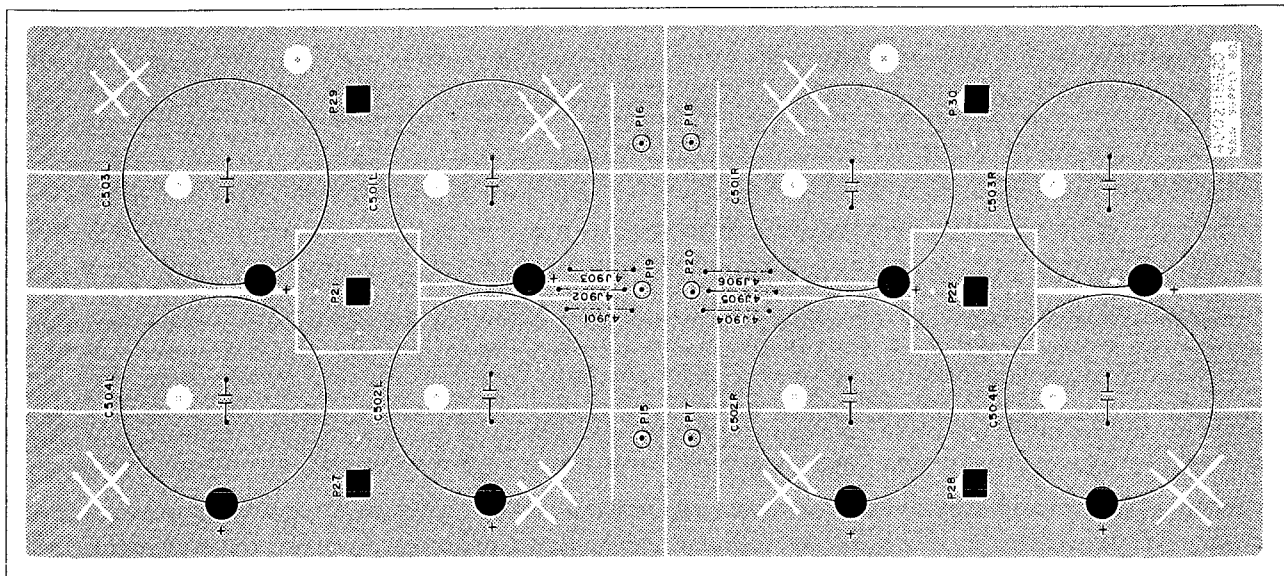

POWER-A BOARD 4002118500, POWER-B BOARD 4002118510

- TOP VIEW

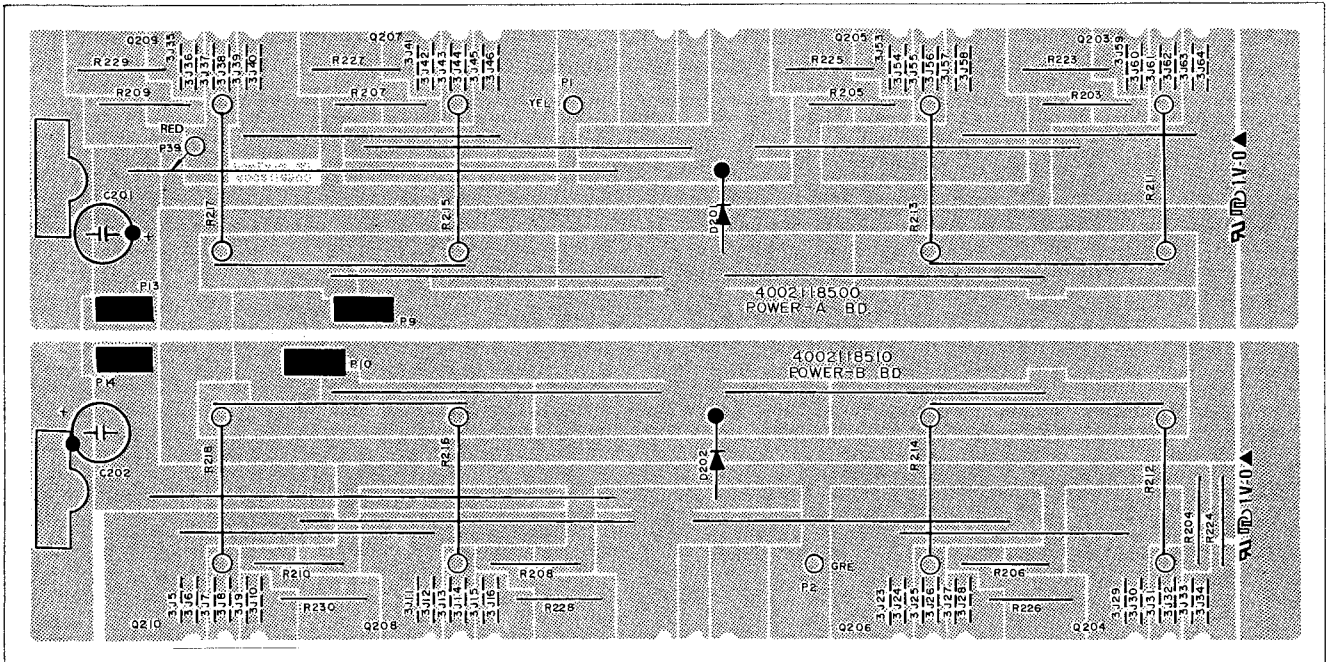

- BOTTOM VIEW

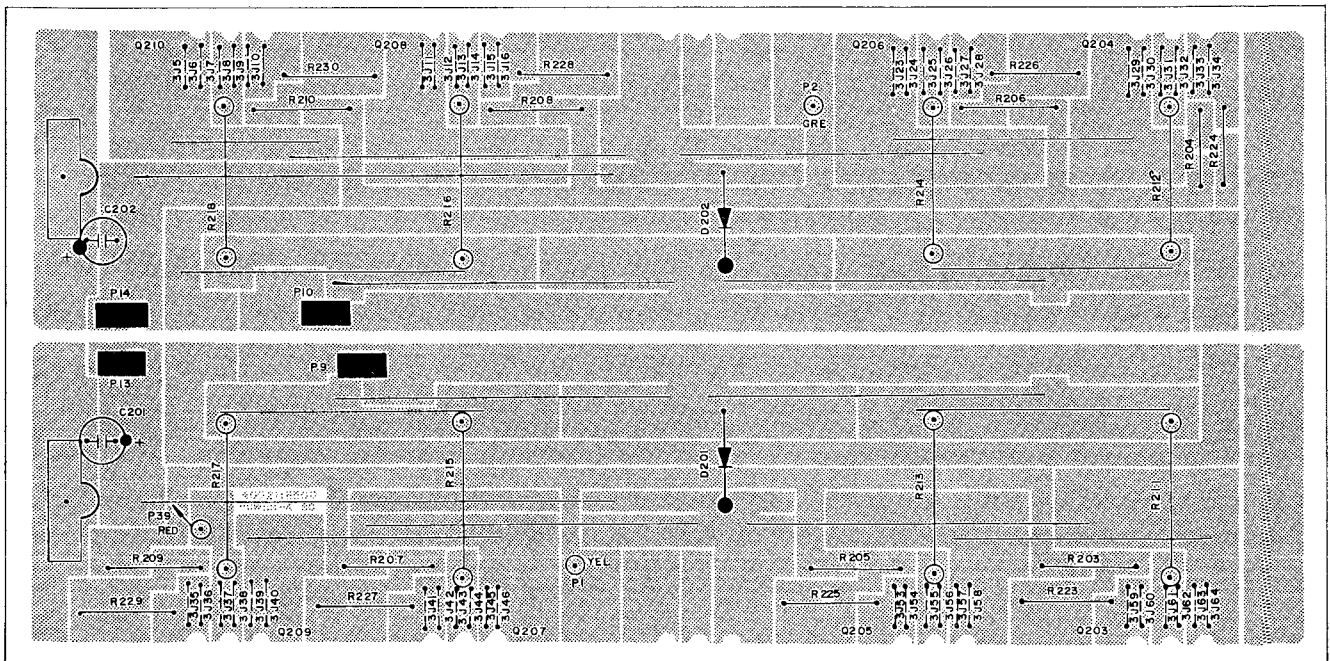



FRONT BOARD 4002118700

-TOP VIEW

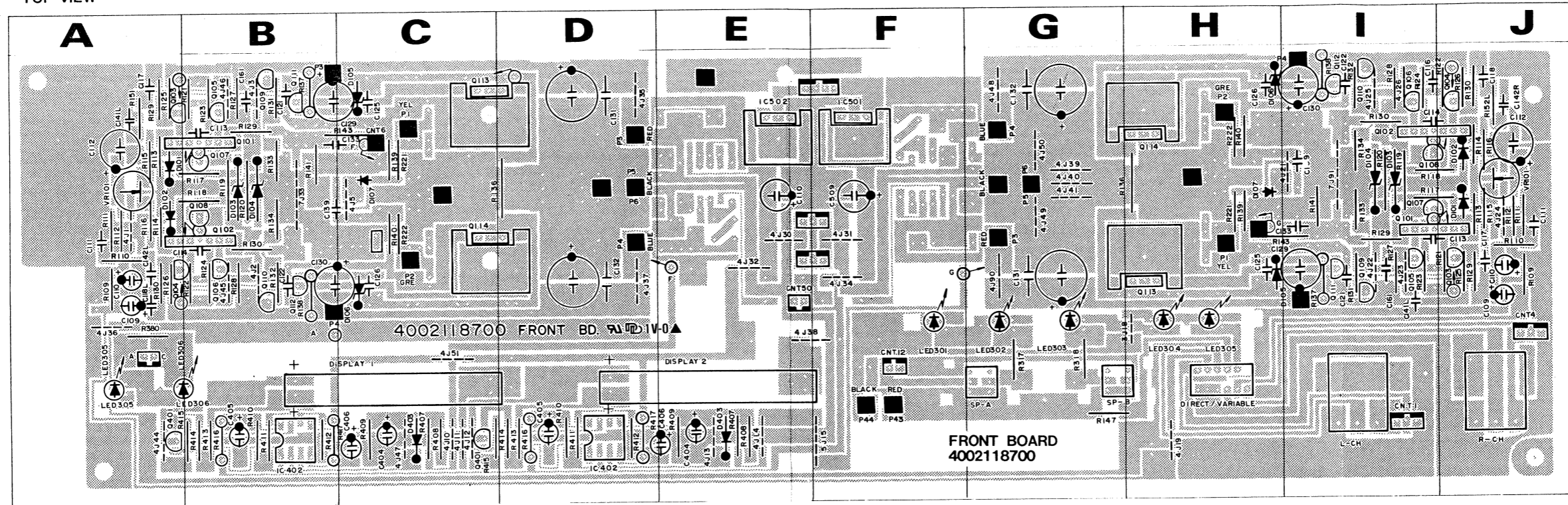

-BOTTOM VIEW

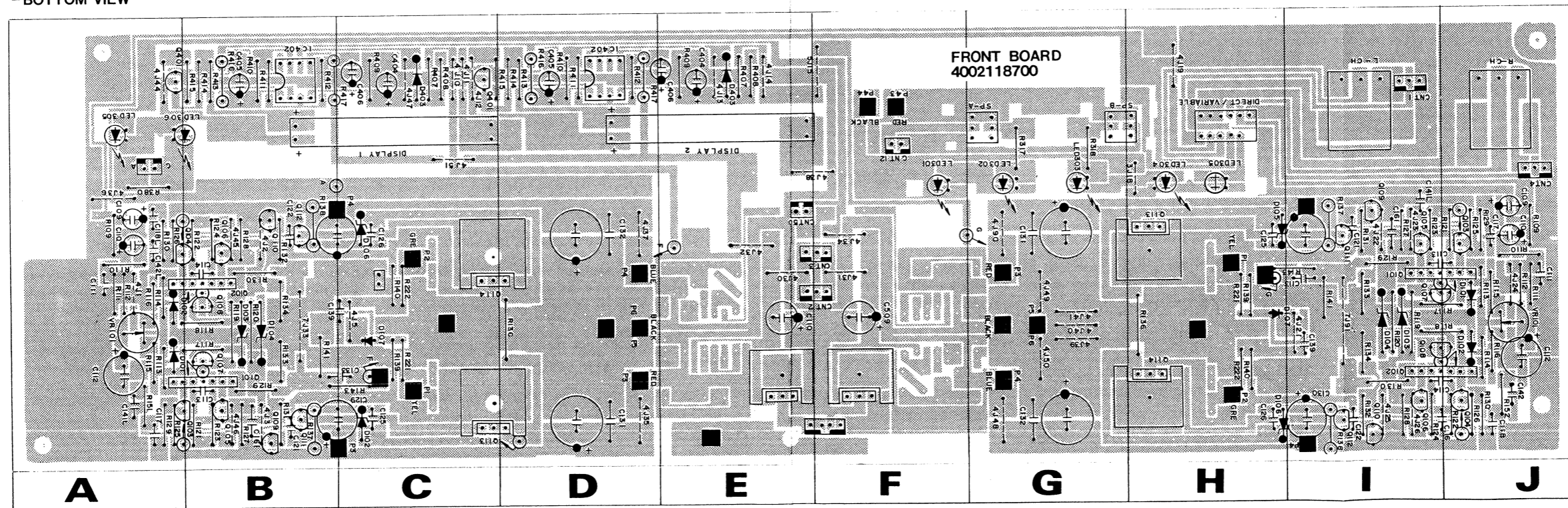

**SP-A BOARD 4002118600**

- TOP VIEW

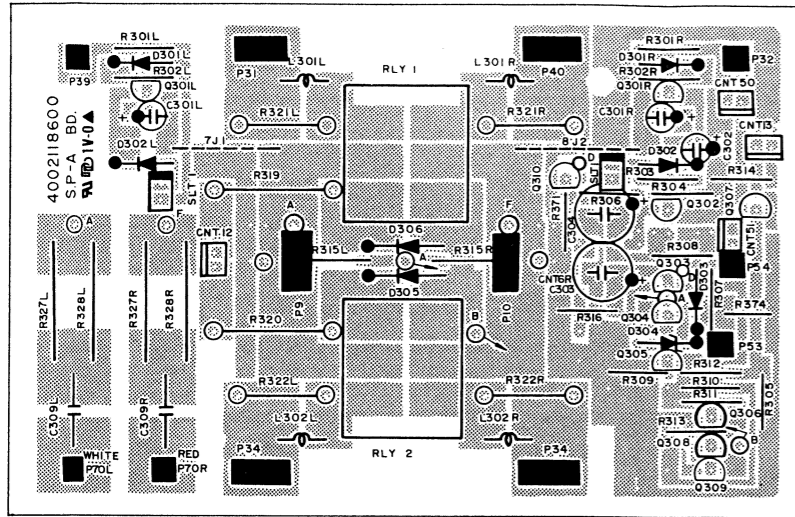

- BOTTOM VIEW

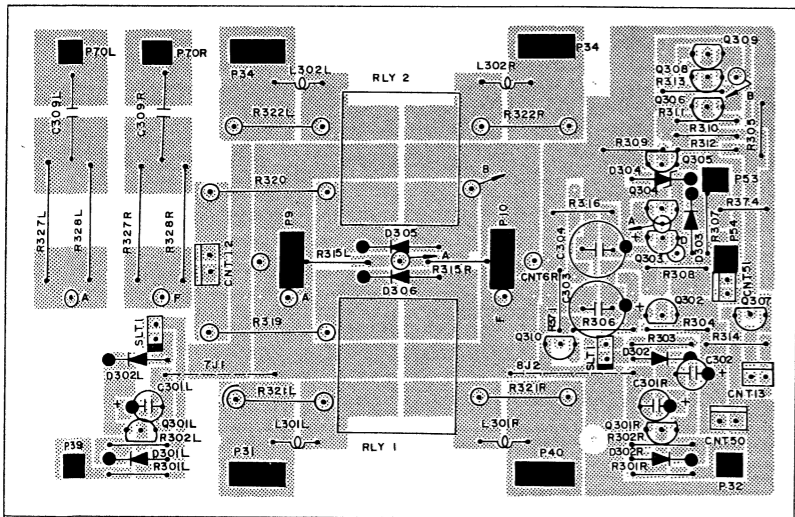

**SP-B BOARD 4002118610**

- TOP VIEW

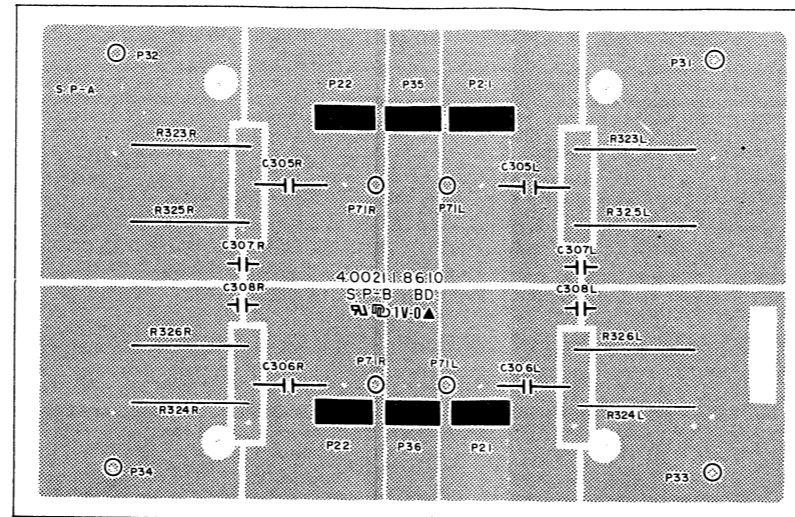

- BOTTOM VIEW

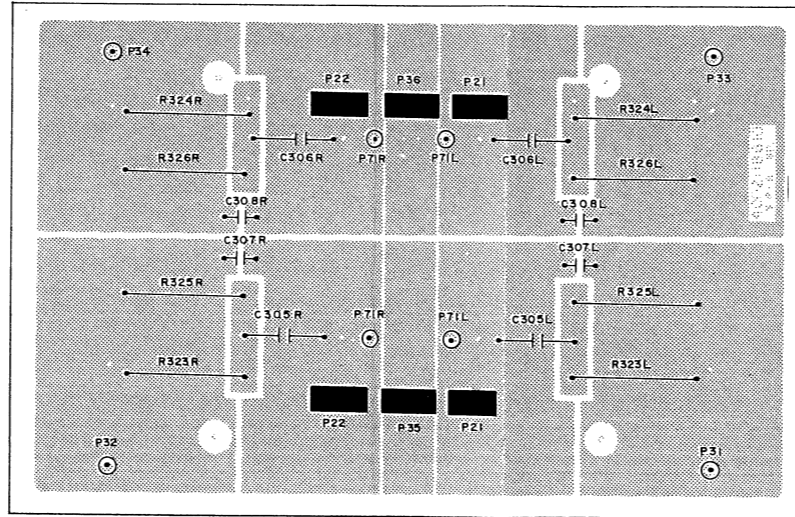

**FUSE BOARD 4002118660**

- TOP VIEW

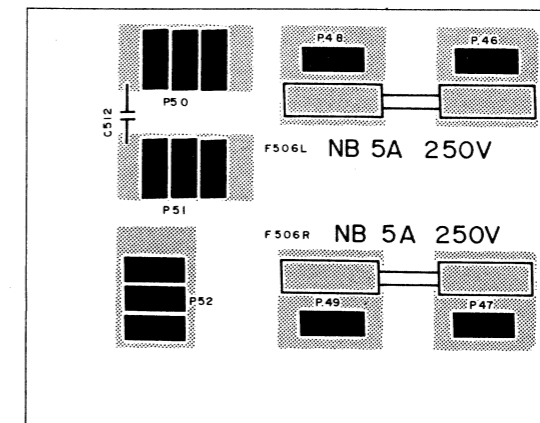

- BOTTOM VIEW

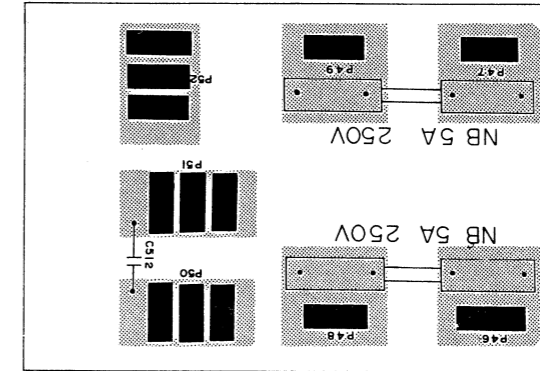

**18V REG BOARD 4002118640**

- TOP VIEW

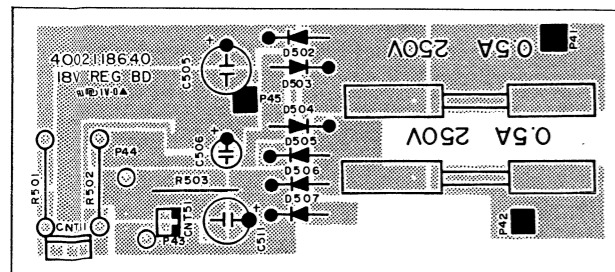

- BOTTOM VIEW

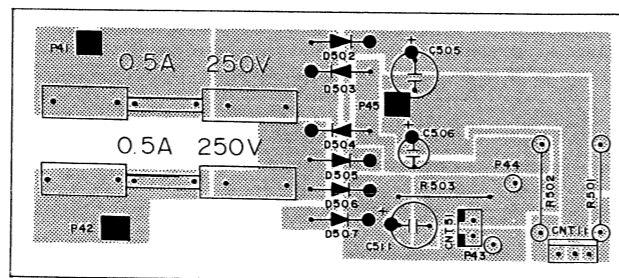

**INPUT BOARD 4002118650**

- TOP VIEW

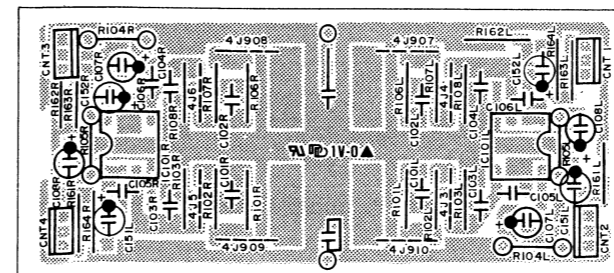

- BOTTOM VIEW

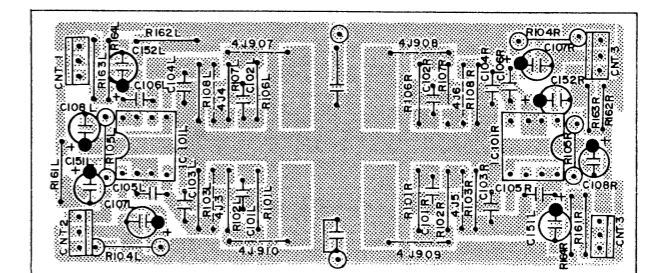

# Block Diagram

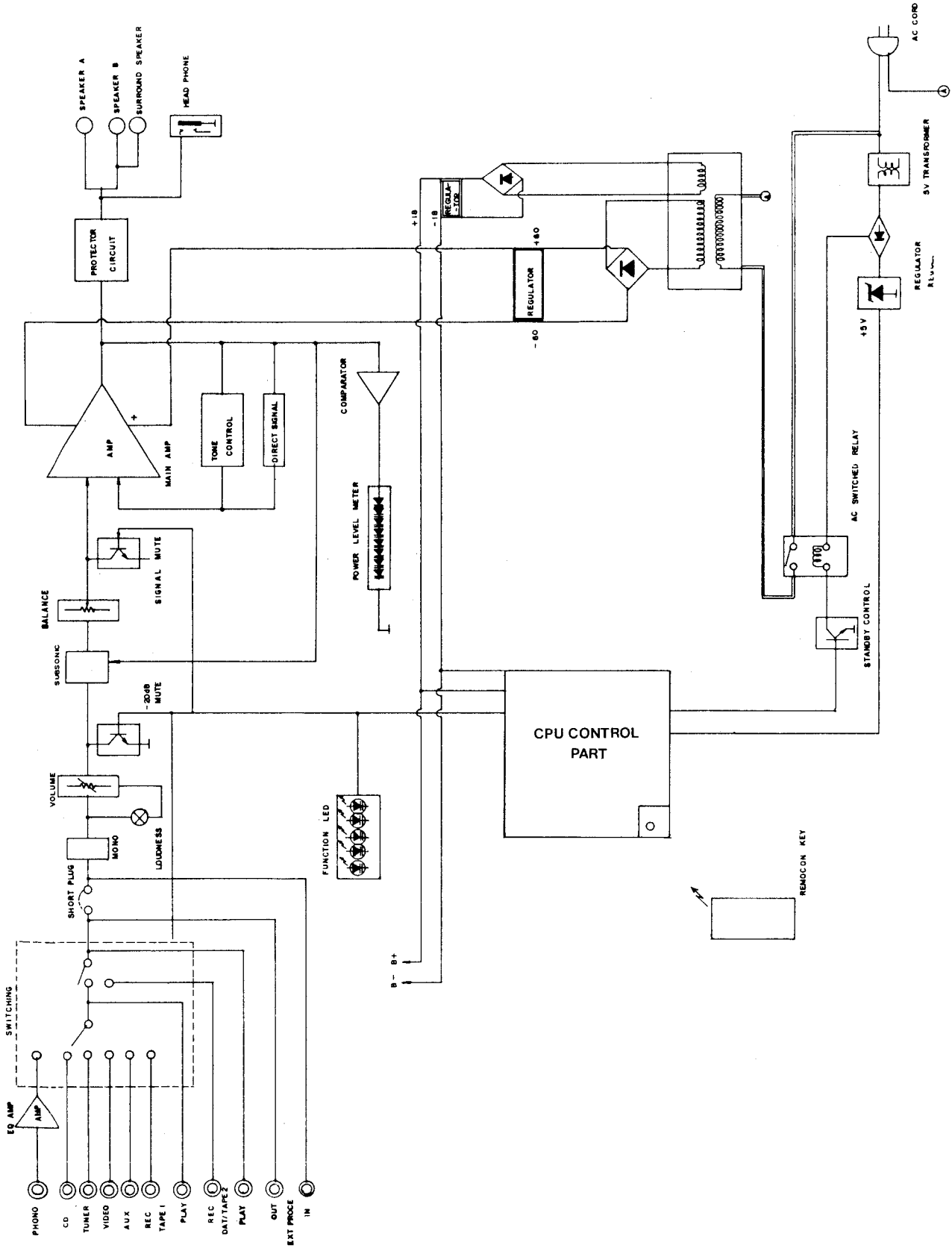

# Mechanical Parts List

No.	Parts No.	Description	Q'ty	Position	Remark
1	048602016212	Panel-Front,Black	1	A3	
2	048545048212	Button-Push, Power	1	A4	
3	6556010020	Spring, Power	1	A4	
4	048545052611	Button-Push, Speaker A	1	A4	
5	048545052612	Button-Push, Speaker B	1	A4	
6	048545052811	Button-Push, C	1	A4	
7	048643004011	Knob, Volume L,R	2	B4	
8	048535019012	Badge	1	B4	
9	048583002011	End-Cap, Right	1	C4	
10	048583002021	End-Cap, Left	1	A3	
11	6555003620	Spring, Speaker	3	A4	
12	8525006710	Bezel Button	1	A3	
13	8553008510	Display-Window, Smoke	1	A3	
14	048533005611	Display-Plate	1	A3	
15	8535021410	Diffuser	1	A3	
16	8523009810	Bezel Volume	1	C4	
17	6042001510	Display-Holder	1	C4	
18	8555022110	Indicator B	1	C4	
19	8555022010	Indicator A	2	B3	
20	6045006810	Holder-LED A	1	A3	
21	6043006010	Holder-LED B	1	B3	
22	4628038810	Switch-Push Speaker A,B	2	C3	
23	6043006110	Holder-LED C	1	C3	
24	4628042010	Switch-Push (4/2)	1	C3	
25		Not used !			
26	3208053110	Volume Rotary	2	C4	
27	6123619410	Frame Under	1	D4	
28	6122413110	Cover Bottom	1	D4	
29	046035101421	Foot-Base, Hot Stamping	2	D4	
30	6725002110	Cushion-Rubber, Black	4	D4	
31	6035101420	Foot-Base	2	E3	
32	6122615110	Frame Front	1	D4	
33	6705004210	Spacer, Black	8	D3	
34	6505085010	Bracket Switch	1	B2	
35	4628052610	Switch-Push, Power	1	B2	A,B
	4628052710	Switch-Push, Power	1	B2	C,D,E,F
36	046122017011	Cover-Top,Black	1	B2	
37	6122615310	Frame, Side Right	1	D3	
38	7503010110	Heatsink Power, Right	2	C2, D3	
39	6505084910	Bracket Heatsink	4	B2, D2 E2	
40	6505070710	Bracket PCB	8	C2, D3	
41	7503010010	Heatsink Power, Left	1	D3	
42	6123406210	Heat Hinder	2	D2	
43	7503010410	Heatsink Power L1	1	C2	
44	6122615320	Frame Side Left	1	B2	
45	7015003110	Bussing	4	C2, D3	
46	6122615210	Frame Back	1	D1	
47	6503012710	Bracket Fuse	1	D1	
48	4458400310	Holder Fuse	4	E2	
49	6528300120	Fastner	4	D1	
50	4408103610	Speaker Terminal, 4P×2	2	D1	
51	4618004010	Switch Slide	2	D1	B
52	4438102010	RCA-Jack	1	F2	
53		Not used !			
54	4308002410	Cord-AC, Power, Black	1	D1	A, B
	4308002310	Cord-AC, Power, Black	1	D1	C,D,E,F
	4308000610	Cord-AC, Power, Black	1	D1	E
55	6518000710	Cord-Stopper, Black	1	E1	A, B
	6518000111	Cord-Stopper, Black	1	E1	C, D, F
	6513000210	Cord-Stopper, Black	1	E1	E
56	4458000210	Holder Fuse	2	F1	A, B
	4458000110	Holder Fuse	2	F1	C,D,E,F
57	6515007010	Holder Voltage	2	F1	B
58	046102023621	Chassis Back, Black	1	F1	A
	046102023631	Chassis Back, Black	1	F1	B
	046102023641	Chassis Back, Black	1	F1	C
	046102023651	Chassis Back, Black	1	F1	D
	046102023661	Chassis Back, Black	1	F1	E
	046102023671	Chassis Back, Black	1	F1	F
59	4408103710	System-Ground	1	F1	
60		Not used !			
61	8129330083	Screw, #3 FTC 3×8 ZNB	4	A4	
62	8109330081	Screw, #3 BTC 3×8ZNY	20	A2, E2, F4	

No.	Parts No.	Description	Q'ty	Position	Remark
63	8109230141	Screw, #2 BTC 3×14ZNY	9	B2, C2, E2	
64	8109330061	Screw, #3 BTC 3×6ZNY	6	C2, B3	
65	8159440083	Screw, WSAM 4×8ZNB	8	B2	
66	8109330083	Screw, #3 BTC 3×8ZNB	7	B1, F1	
67	8159440081	Screw, WSAM 4×8ZNY	12	C3	
68	8109535081	Screw, #3 BT 3.5×8ZNY	38	C1, B2 E2, B3	
69	8109235081	Screw, #2 BT 3.5×8ZNY	32	B2, C2 D2, E2	
70	8119330081	Screw, #3 PTC 3×8ZNY	4	E2	
71	8109230083	Screw, #2 BTC 3×8ZNB	9	E2	
72	8109535083	Screw, #3 BT 3.5×8ZNB	6	E1, F2	
73	8209540011	Nut Flunge 0.4ZNY	8	C2, D2	
74	8159330101	Screw, #3 WPTC 3×10ZNY	4	D4	

# Exploded View of Cabinet & Chassis

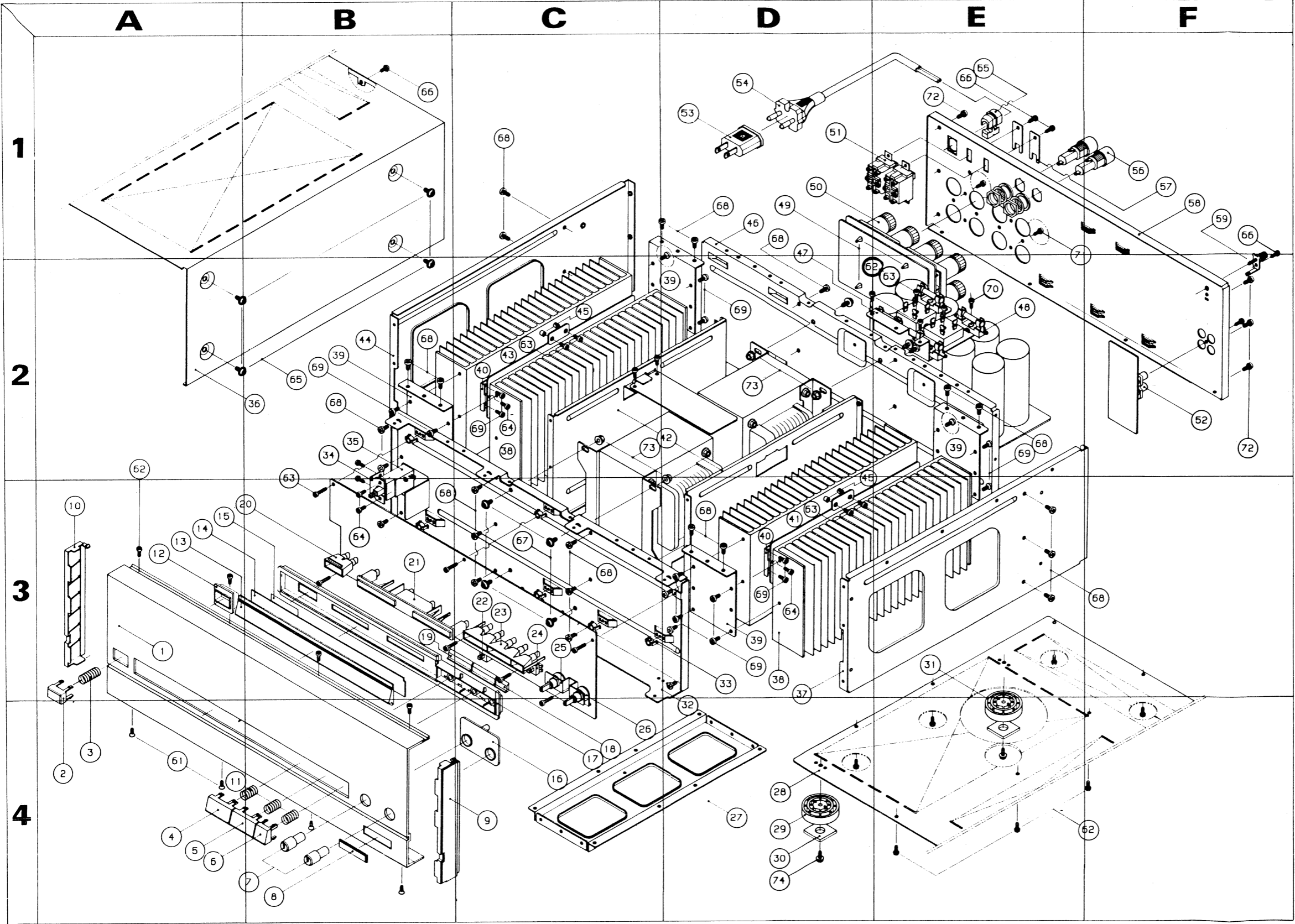

# Point to Point Wiring Diagram(I)

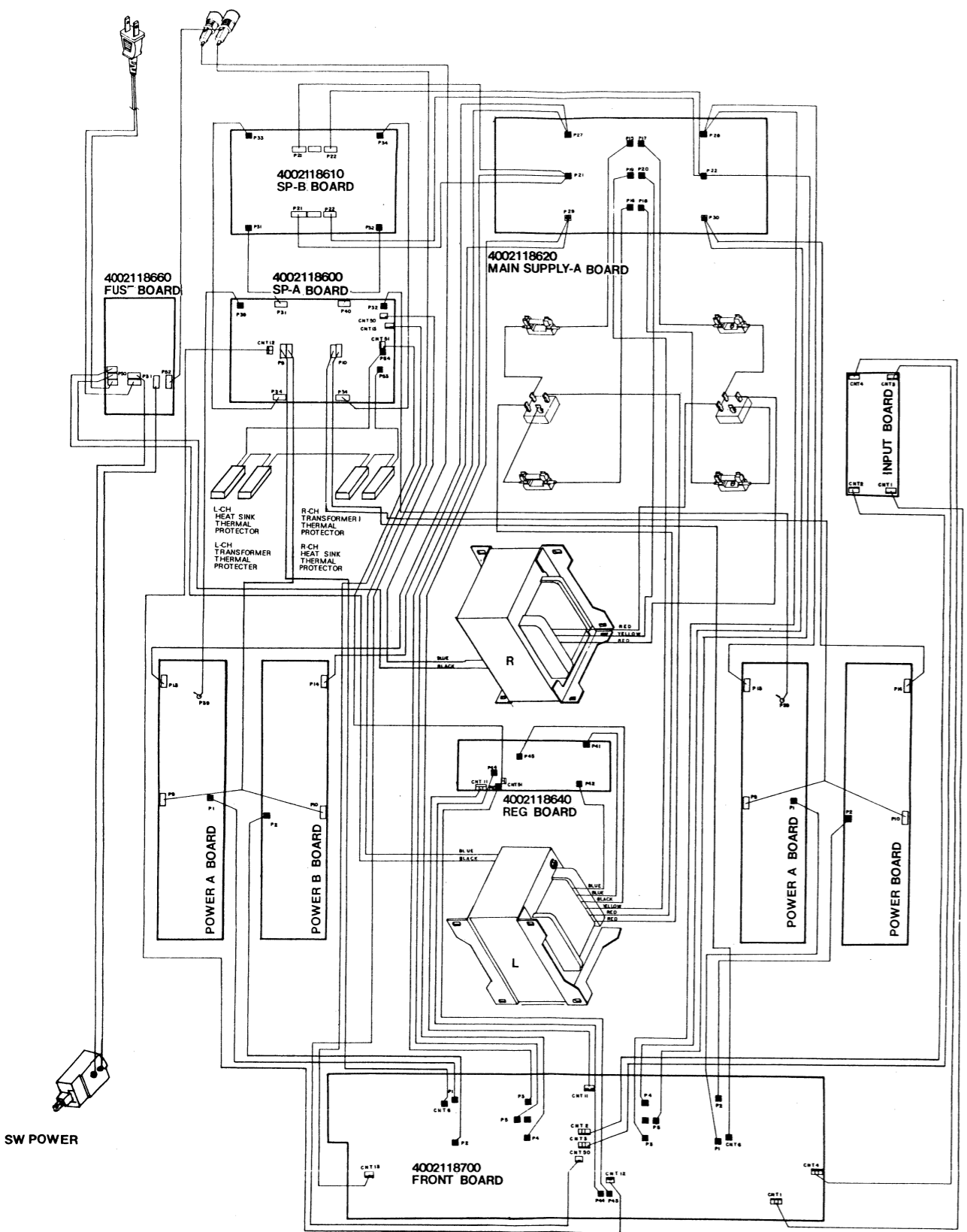

# Point to Point Wiring Diagram(II)

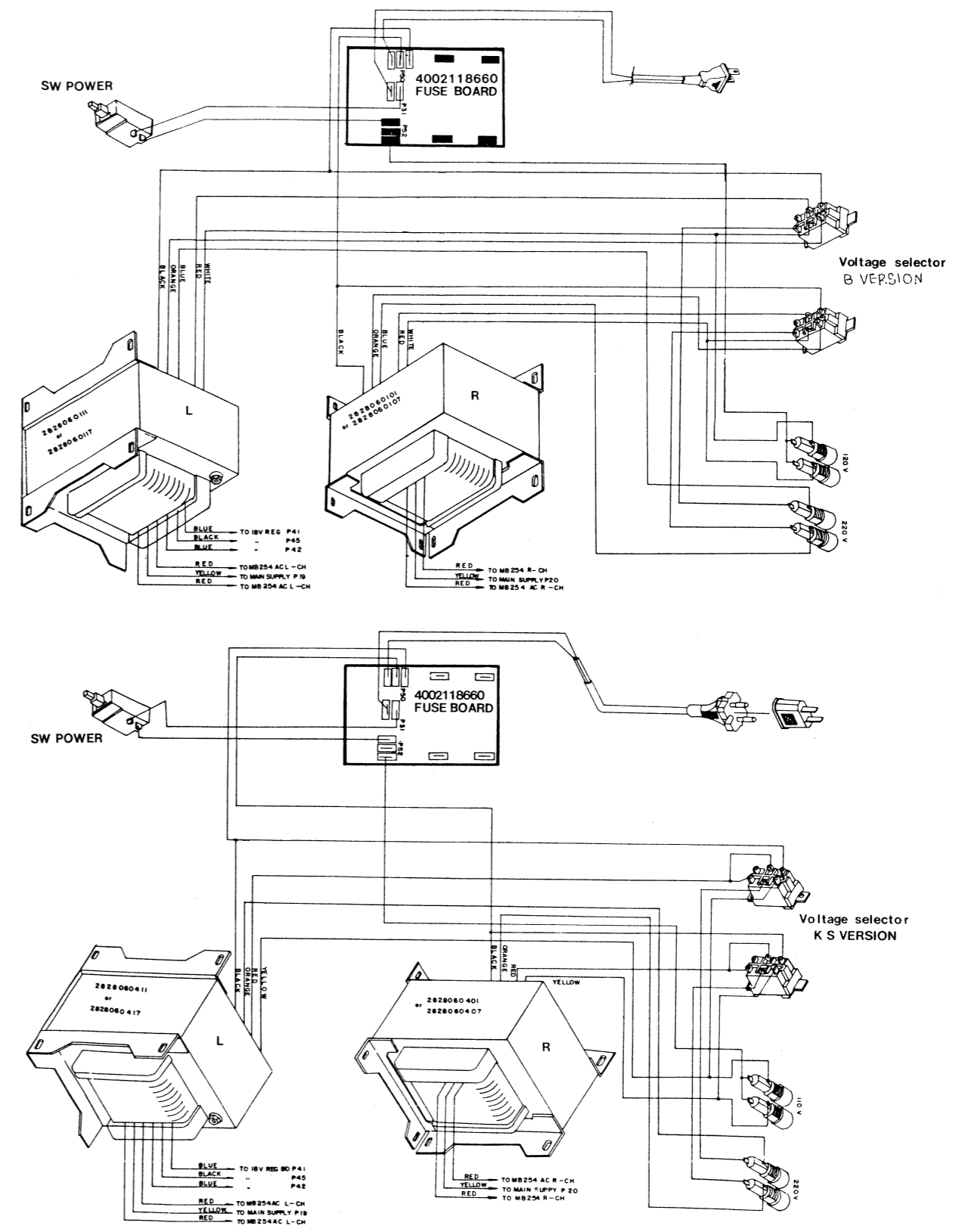

# Schematic Diagram AM 7040

1  
2  
3  
4  
5

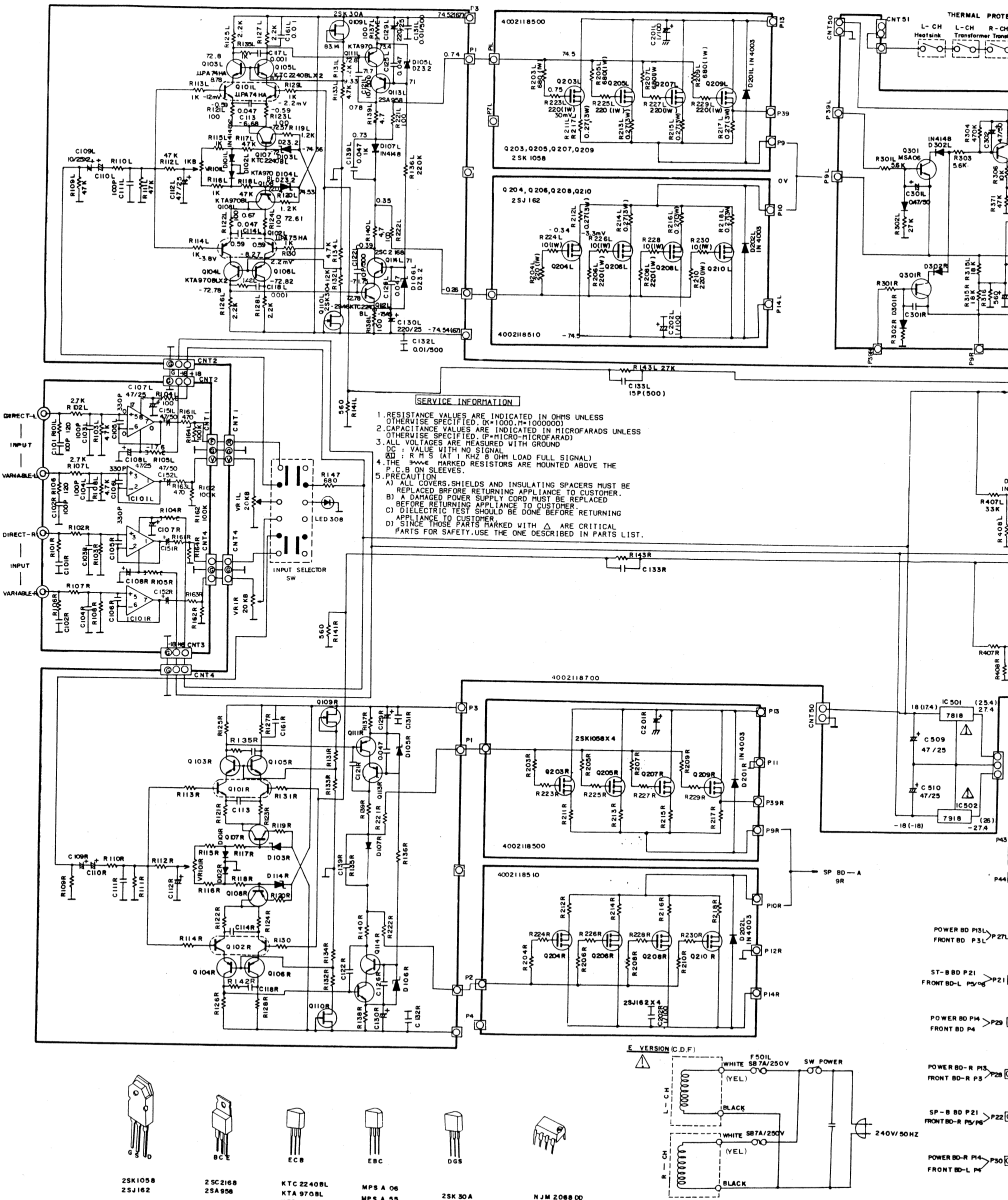

**A** **B** **C** **D**

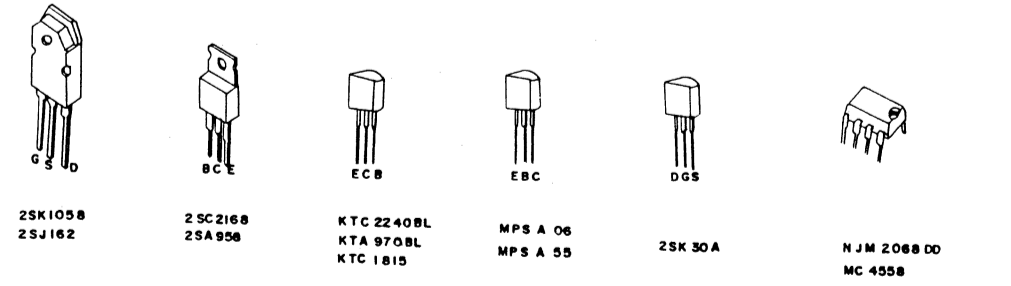

POWER BD P15L  
FRONT BD P3L  
 ST-B BD P21  
FRONT BD-L P5/P6  
 POWER BD P4  
FRONT BD P4  
 POWER BD-R P13  
FRONT BD-R P5  
 SP-B BD P21  
FRONT BD-R P5/P6  
 POWER BD-R P14  
FRONT BD-L P4

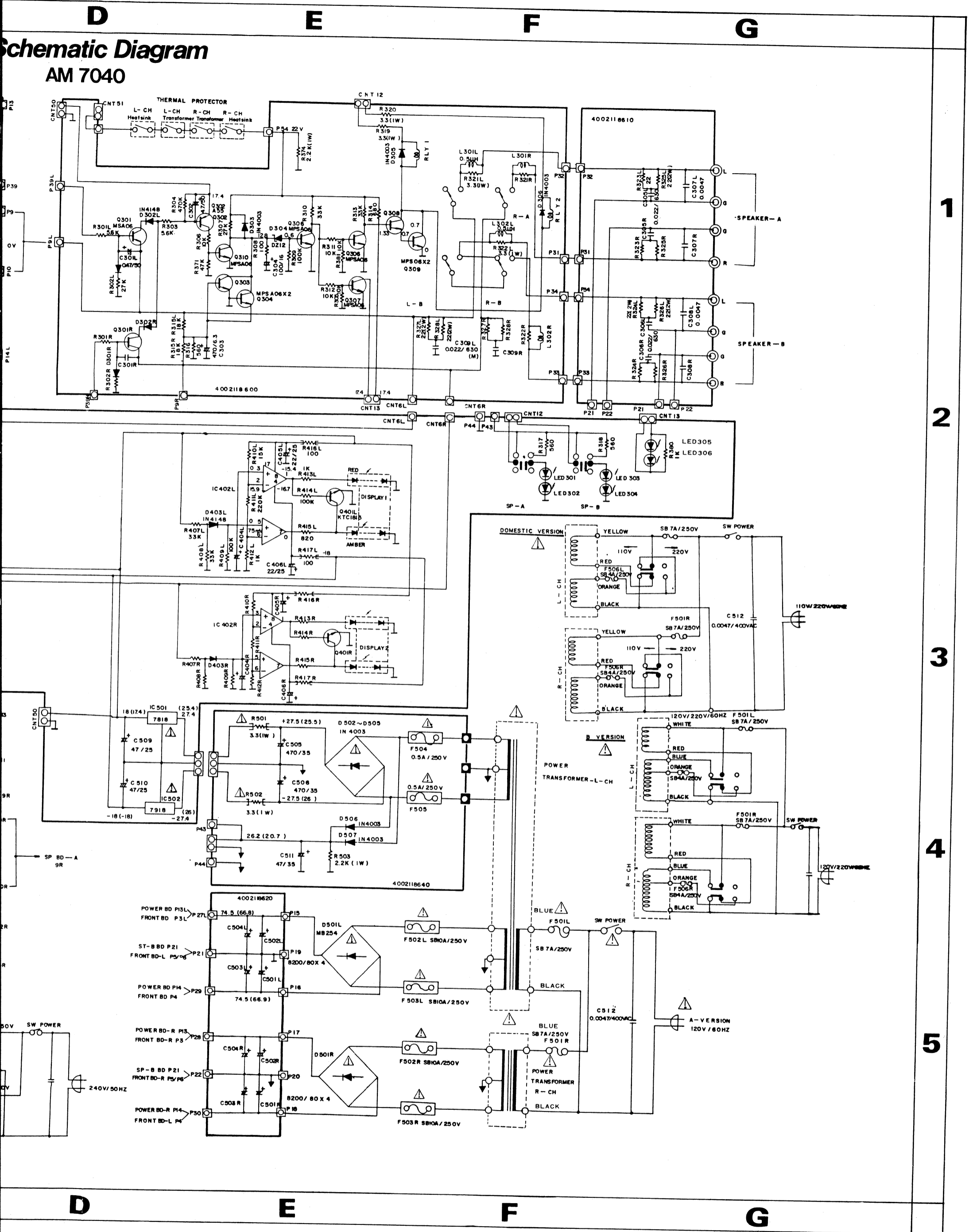



# Block Diagram (AM-7040 ONLY)

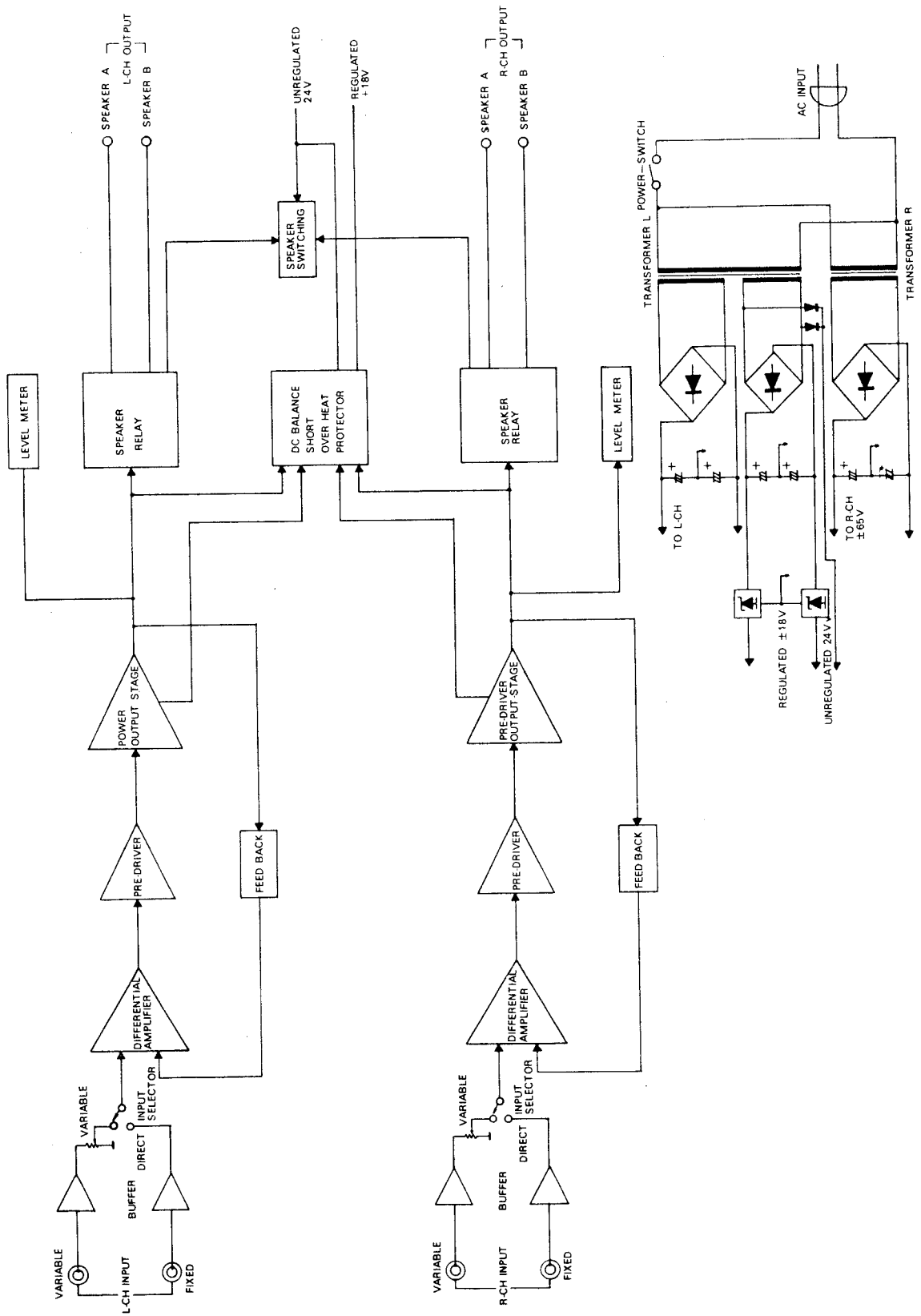

# Point to Point Wiring Diagram (III)

