

SERVICE MANUAL

R-925R / R-925RDS

AUDIO/VIDEO AC-3, PRO-LOGIC RECEIVER

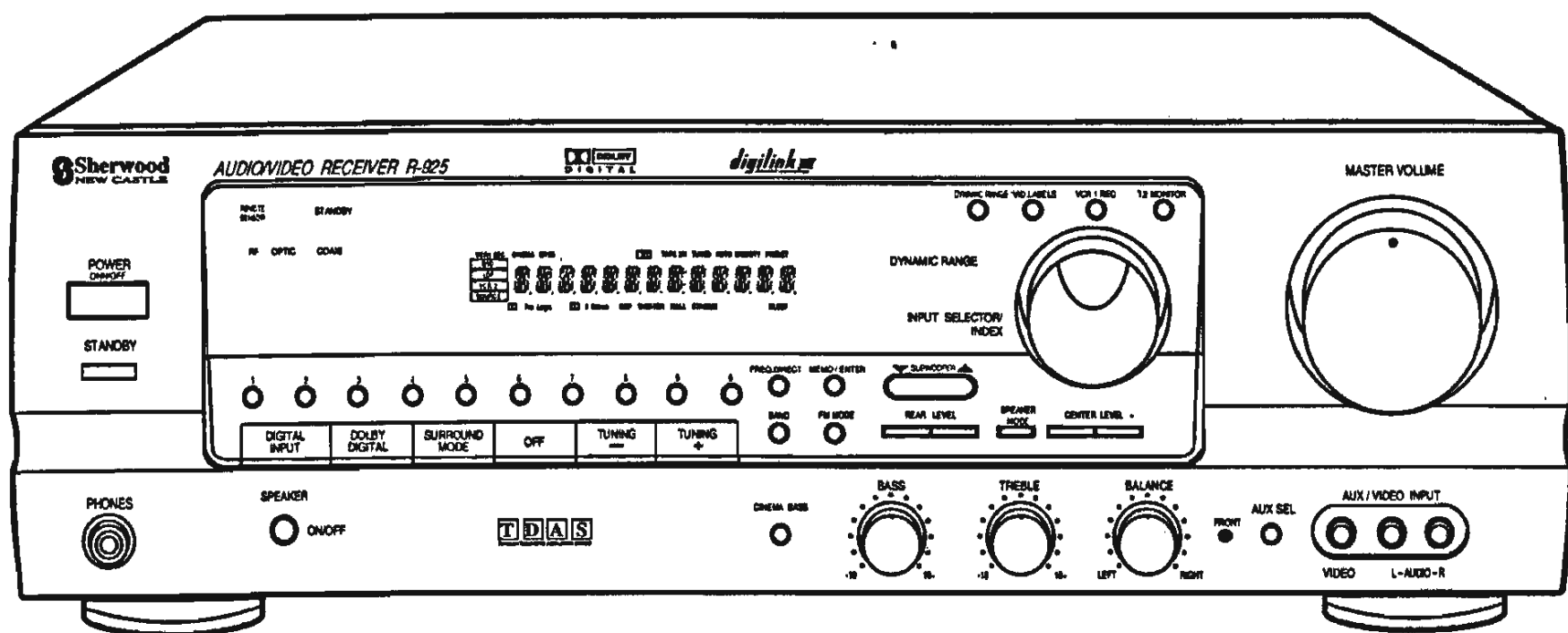

■ CONTENTS ■

SAFETY PRECAUTIONS	2	MECHANICAL PARTS LIST	30
SPECIFICATIONS	3	EXPLODED VIEW	31
BLOCK DIAGRAM	10	PRINTED CIRCUIT BOARDS	33
WIRING DIAGRAM	12	ELECTRICAL PARTS LIST	43
CIRCUIT DESCRIPTION	14	IC FUNCTIONAL BLOCK DIAGRAM	55
ALIGNMENT PROCEDURES	25	SCHEMATIC DIAGRAMS (I), (II), (III), (IV), (V) ..	59
TROUBLESHOOTING	28	SCHEMATIC DIAGRAMS (VI), (VII), (VIII), (IX) ..	69

 **Sherwood®**

SAFETY PRECAUTIONS

WARNING

Before servicing this unit, familiarize yourself with the following precautions:

1. Many electrical and mechanical parts in this chassis have special safety characteristics that often pass unnoticed and the protection afforded by them cannot necessarily be obtained by using replacement components rated for higher voltage, wattage, etc. Replacement parts that have these special safety characteristics are identified in this manual and its supplements: electrical components having such features are identified by \triangle in the schematic diagram and the parts list.

Before replacing any of these components, read the parts list in this manual carefully. The use of substitute replacement parts that do not have the same safety characteristics as specified in the parts list may create shock, fire, or other hazards.

2. Before returning the set to the customer, always do an AC leakage current check on the

exposed metal parts of the cabinet, such as terminals, screw heads, and metal overlays, to be sure the set is safe to operate danger of electrical shock. Plug the AC line cord directly into a 120 V AC outlet (120 V AC version only). (Do not use a line isolation transformer during this check.) Be sure your AC voltmeter has a sensitivity of 5000Ω per volt or greater. Then connect a 1500Ω 10 watt resistor, paralleled by a $0.15 \mu\text{F}$ 150 V AC capacitor, between a known good earth ground (such as a water pipe, or conduit) and the exposed metallic is parts, one at a time. Measure the AC voltage across the combination of a 1500Ω resistor and a $0.15 \mu\text{F}$ capacitor. Reverse the AC plug at the AC outlet and repeat AC voltage measurements for each exposed metallic part. Voltage measured must not exceed 0.75V RMS. This corresponds to 0.2 mA AC. Any value exceeding this limit constitutes a potential shock hazard and must be corrected immediately.

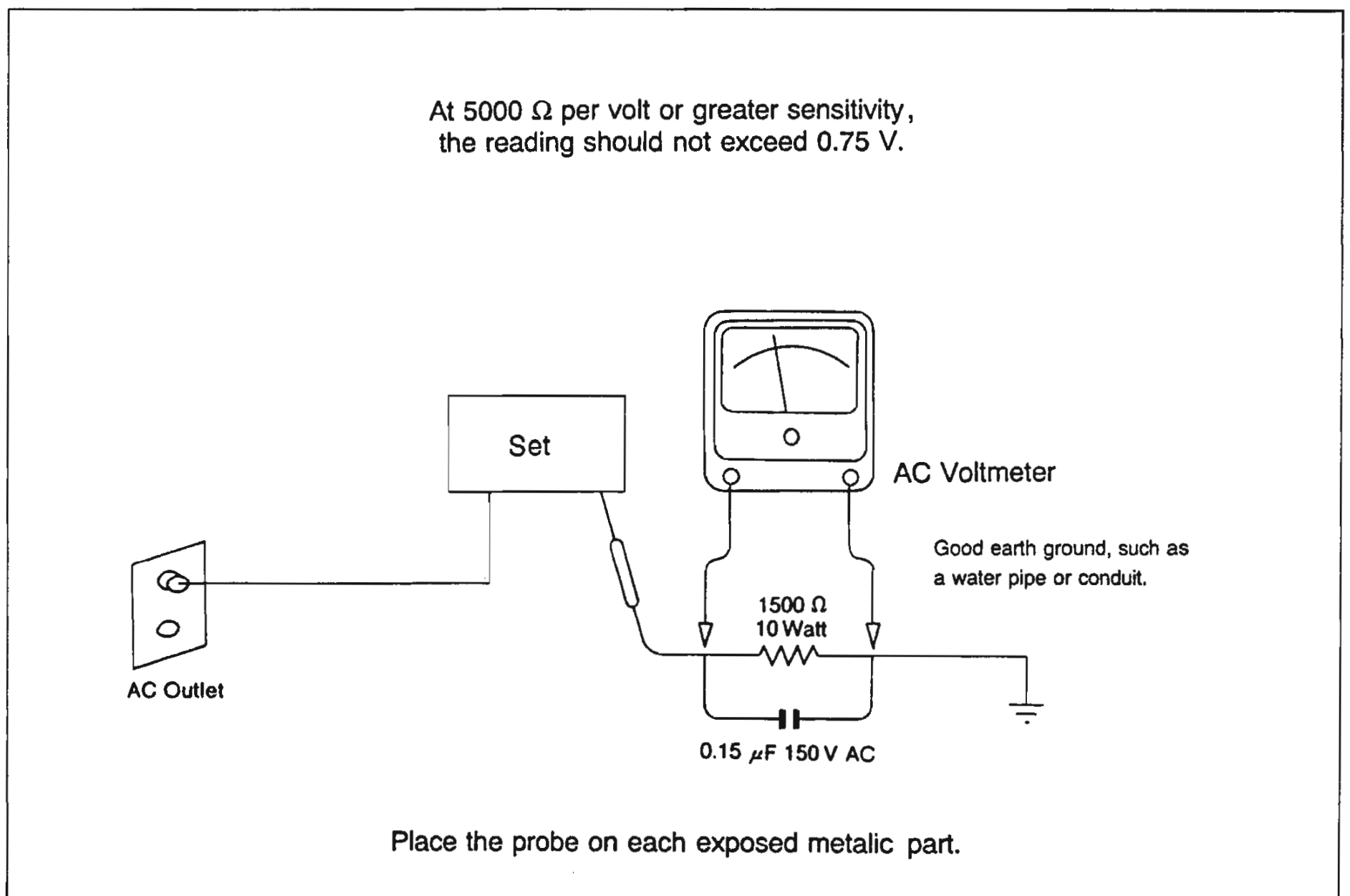

SPECIFICATIONS

● FRONT AMP SECTION (ALL)

Measuring methods are based on IHF and IEC standard 268-3

Measurements conditions, unless otherwise noted :

Output resistive load = (8) ohms / Both channel driven

Tone(Bass,Treble), Balance, EQ control : Center Position , Other SW's : OFF

Nominal input level : 5mV for MM, 0.5mV for MC, 500mV for general purpose inputs

Power figures should be kept minimum 10min. between 15 and 35°C

Terminator : 100ohm for MC, 1kohm for MM and general purpose inputs

Filter : IHF-A filter.

R/O = Rated Output

NO	DESCRIPTION	INPUT	FREQ.	REMARK	UNIT	LIMIT L/R	NOMINAL L/R
1	INPUT SENSITIVITY	CD	1kHz		mV	200±30	200±20
		MM	1kHz		mV	3.5±0.5	3.5±0.3
		MC	1kHz		mV		
		MIC	1kHz		mV		
2	CHANNEL BALANCE	CD	1kHz	R/O TO -40dB	dB	±3	±2
			1kHz				
3	DAMPING FACTOR	CD	1kHz				
4	RESIDUAL NOISE	CD	1kHz	VOL min.	mV	≤1	
			1kHz	VOL max.	mV		
5	TOTAL HARMONIC DISTORTION	CD(500mV)	(20)Hz	R/O / 1W	%	≤0.2	≤0.09
			1kHz	"	%	≤0.2	≤0.09
			(20)KHz	"	%	≤0.3	≤0.2
6	CONTINUOUS AVERAGE POWER at (0.2)% THD	CD	(20)Hz	(8)ohms	W	100	102
			1kHz	"	W	100	102
			(20)KHz	"	W	100	102
7	IMD(SMPTE)	CD(500mV)	60Hz=4	R/O	%	≤0.1	≤0.07
			7kHz=1	1W	%	≤0.1	≤0.07
8	S/N RATIO, IHF-A FILTER	CD(500mV)	1kHz	R/O	dB	≥90	≥93
			1kHz	1W	dB		
		MM(5mV)	1kHz	R/O	dB	≥68	≥72
			1kHz	1W	dB		
		MC(0.5mV)	1kHz	R/O	dB		
			1kHz	1W	dB		
9	CHANNEL SEPARATION	CD(500mV)	100Hz	R/O-3dB	dB	≥45	≥55
			1kHz	"	dB	≥45	≥55
			10kHz	"	dB	≥40	≥45
10	FUNCTION CROSSTALK	CD→AUX	1/10 kHz	"	dB	≥60/40	≥65/45
		CD→MM	1/10 kHz	"	dB	≥60/40	≥65/45
		MM→CD	1/10 kHz	"	dB	≥60/40	≥65/45
		→	1/10 kHz	"	dB		
11	FREQUENCY RESPONSE (-3dB)	CD(500mV)		1W	Hz~kHz	20~50	10~60
12	TONE CONTROL , ±(10)dB	CD	100Hz	1W	dB	±10±2	±10±1
			10kHz	"	dB	±10±2	±10±1
13	SUBWOOFER OUT (1ch input)	CD(200mV)	30Hz	M-Vol Max	V	1.6±0.3	1.6±0.2
14	PHONO EQUALIZATION	W	100Hz	TAPE OUT	dB	+13.1±1.5	+13.1±1
			10KHz	"	dB	-13.7±1.5	-13.7±1
15	INPUT OVERLOAD at 0.5% THD	CD	1kHz	S/P OUT	mV		
		MM	1kHz	TAPE OUT	mV	≥120	≥140
		MC	1kHz	"	mV		
		MIC	1kHz	"	mV		

NO	DESCRIPTION	INPUT	FREQ.	REMARK	UNIT	LIMIT L/R	NOMINAL L/R
16	HEADPHONE OUTPUT H/P = 64ohms	CD (150)mV	1kHz	R/O	mV		
			1kHz	R/O	mV		
17	FTC POWER 20Hz~20kHz at ()% THD	CD	20Hz	"	W		
			1kHz	"	W		
			20kHz	"	W		
18	DIN POWER at 1% THD	CD	1kHz	"	W		
19	DYNAMIC POWER OUTPUT 20 cycle ON,480 cycle OFF	CD	1kHz	()ohms	W		
20	POWER BANDWIDTH -3dB	CD		R/O	Hz~kHz		
21	SLEW RATE	CD	1kHz	R/O	V/usec		
22	SLEW-FACTOR	CD(500mV)					
23	INPUT IMPEDANCE	CD	1kHz		kohm		
		MM	1kHz		kohm		
		MC	1kHz		kohm		
		MIC	1kHz		kohm		

● REAR AMP SECTION

Measurements conditions : Input level (350mV)

Rear level max., Master volume adj. Delay time 20ms

NO	DESCRIPTION	INPUT	FREQ.	REMARK	UNIT	LIMIT L/R	NOMINAL L/R
1	POWER OUTPUT 1% THD	CD	1kHz	(8)ohms	W	≥90	≥93
2	TOTAL HARMONIC DISTORTION	CD	1kHz	1W	%	≤1	≤0.7
3	S/N RATIO DOLBY IHf-A FILTER, THEATER HALL STADIUM CHURCH	CD		R/O	dB	≥55	≥63
		CD		"	dB	≥55	≥63
		CD		"	dB	≥55	≥63
		CD		"	dB	≥55	≥63
		CD		"	dB	≥55	≥63
4	FRE RES.(ONLY DOLBY) ±3dB	CD	1kHz	1W	Hz~kHz	100~6	80~7

● CENTER AMP SECTION

Measurements conditions : Input level (350mV)

Center level max., Master volume adj.

NO	DESCRIPTION	INPUT	FREQ.	REMARK	UNIT	LIMIT L/R	NOMINAL L/R
1	POWER OUTPUT at 0.3% THD	CD	1kHz	(8)ohms	W	≥90	≥93
2	TOTAL HARMONIC DISTORTION	CD	1kHz	1W	%	≤0.3	≤0.2
3	S/N RATIO, IHf-A FILTER	CD		R/O	dB	≥55	≥60
4	FRE. RESPONSE LARGE DOLBY MODE SMALL	CD		1W	Hz~kHz	20~18K	15~20K
		CD		1W	Hz~kHz	135~18K	120~20K

● VIDEO SECTION

NO	DESCRIPTION	INPUT	FREQ.	REMARK	UNIT	LIMIT L/R	NOMINAL L/R
1	OUTPUT LEVEL at 75ohms	VCR1(1Vp-p)	1MHz		Vp-p	1±0.2	1±0.1
2	FREQUENCY RESPONSE	"	1MHz		Hz~MHz	DC~6	DC~6,3
3	S/N RATIO	"	1MHz		dB	40	45
4	CROSSTALK	"	1MHz		dB	40	45

● AC-3 SECTION (ALL)

Measurements conditions, unless otherwise noted : Input Function : LD

Digital Input Mode : LD RF

Speker Mode : Center:LARGE, Sub-Woofer:YES

Main Vol Position : 1 Vrms Output Position

Trim Vol Position : All "0 dB"

Test Point : Pre-Out

Test disc : DOLBY TEST LD VERSION 1.0

Center, Rear delay : 0 ms

NO	DESCRIPTION		SIGNAL	INPUT	CHAPTER	UNIT	LIMIT	NOMINAL
1	Output Level		1kHz	0dB	38	V	0.9±0.3	0.9±0.2
	MEASUREMENT		L	C	R	LS	RS	SW
	Main Vol Level : "58"Position		30Hz	0dB	18	V	3.0±0.8	3.0±0.5
	MEASUREMENT		L	C	R	LS	RS	SW
2	Output Level		1kHz	0dB	38	mV	≤0.2	≤0.15
	MEASUREMENT		L	C	R	LS	RS	SW
	at MIN.VOL.		30Hz	0dB	18	mV	≤0.2	≤0.15
	MEASUREMENT		L	C	R	LS	RS	SW
3	S/N Ratio	PRE-OUT : 100mV "A"Weighted	1kHz	-20dB	6	dB	≥60	≥65
	MEASUREMENT		L	C	R	LS	RS	SW
		PRE-OUT : 1V Unweighted	30Hz	0dB	18	dB	≥60	≥65
	MEASUREMENT		L	C	R	LS	RS	SW
4	T.H.D	PRE-OUT : 100mV	1kHz	-20dB	6	%	≤0.5	≤0.3
	MEASUREMENT		L	C	R	LS	RS	SW
		PRE-OUT : 1V	30Hz	0dB	18	%	≤0.3	≤0.2
	MEASUREMENT		L	C	R	LS	RS	SW
5	Channel Separation	L	1kHz	0dB	8	dB	Other Channel	
	MEASUREMENT		L	C	R	LS	RS	SW
		C	1kHz	0dB	10	dB	≥60	≥65
	MEASUREMENT		L	C	R	LS	RS	SW
		R	1kHz	0dB	12	dB	L ↔ R	
	MEASUREMENT		L	C	R	LS	RS	SW
		LS	1kHz	0dB	14	dB	≥50	≥55
	MEASUREMENT		L	C	R	LS	RS	SW
		RS	1kHz	0dB	16	dB	ALL ↔ Sub-Woofer	
	MEASUREMENT		L	C	R	LS	RS	SW
		SW	30Hz	0dB	18	dB	≥30	≥35
	MEASUREMENT		L	C	R	LS	RS	SW
6	Frequency Response	Sub-woofer:YES Center:SMALL	30Hz (1kHz)	0dB	20 (38 :ref)	dB	≤-15	≤-20
	MEASUREMENT		L	C	R	LS	RS	SW
	at M-Vol Level:"50"	Rear:Yes	1kHz (30Hz)	0dB	38 (20 :ref)	dB	≤-30	≤-35
	MEASUREMENT		L	C	R	LS	RS	SW
		Sub-woofer:NO Center:LARGE	30Hz (1kHz)	0dB	20 (38 :ref)	dB	8.5±1.5	8.5±1
	MEASUREMENT		L	C	R	LS	RS	SW

NO	DESCRIPTION	SIGNAL	INPUT	CHAPTER	UNIT	LIMIT	NOMINAL	
7	Dialog Normalization	1kHz	0dB	43	dB	-10±1	-10±0.5	
	MEASUREMENT	L	C	R	LS	RS	SW	
	Main Vol Level : "50"Position	30Hz	0dB	43	dB	-10±1	-10±0.5	
	MEASUREMENT	L	C	R	LS	RS	SW	
8	Down Mix level	AC-3 mode						
	MEASUREMENT	L	C	R	LS	RS	SW	
	Main Vol Level :	Stereo Key : ON	1kHz	0dB	38	dB	-3.2±0.5	-3.2±0.3
	MEASUREMENT	L	C	R	LS	RS	SW	
	"50"Position	Sub-woofer : NO						
MEASUREMENT	L	C	R	LS	RS	SW		
9	Down Mix Frequency Response	same as above	30Hz(1kHz)	0dB	20(38:ref)	dB	±1	±0.5
	Main Vol Level : "50"Position	MEASUREMENT	L	C	R	LS	RS	SW
10	Channel across level	C-> L, R Center 0dB Setting Center : No	1kHz	0dB	10	dB	-3 ± 1	-3 ± 0.5
	MEASUREMENT	L	C	R	LS	RS	SW	
	Main Vol level	Ls-> L Ls 0dB Setting Rear : No	1kHz	0dB	14	dB	-3 ± 1	-3 ± 0.5
	MEASUREMENT	L	C	R	LS	RS	SW	
	"58" Position	Rs-> R Rs 0dB Setting Rear : No	1kHz	0dB	16	dB	-3 ± 1	-3 ± 0.5
	MEASUREMENT	L	C	R	LS	RS	SW	
		SubWoofer -> L, R Sub 0dB Setting, Sub : No	30Hz	0dB	18	dB	-5.5 ± 1	-5.5 ± 0.5
MEASUREMENT	L	C	R	LS	RS	SW		
11	LFE Signal across level	L/C/R/Ls/Rs -> Sub Out (1) Sub : Yes	30Hz	0dB	20	V	1.8 ± 0.5	1.8 ± 0.3
	MEASUREMENT	L	C	R	LS	RS	SW	
	Main Vol level	L/C/R/Ls/Rs -> Sub Out (2) (1): 0dB, Stereo: On, Sub: Yes	30Hz	0dB	20	dB	-11 ± 2	-11 ± 1
	MEASUREMENT	L	C	R	LS	RS	SW	
	"50" Position	C/Ls/Rs -> L, R (3) (2): 0dB, Stereo: On, Sub: No	30Hz	0dB	20	dB	-5.5 ± 3	-5.5 ± 2
MEASUREMENT	L	C	R	LS	RS	SW		
12	LFE Signal across level	L/C/R/Ls/Rs/LFE-> Sub Out (1) Sub : Yes	30Hz	0dB	22	V	2.5 ≤ ± 0.8	2.5 ≤ ± 0.5
	MEASUREMENT	L	C	R	LS	RS	SW	
	Main Vol level	L/C/R/Ls/Rs/LFE ->Sub Out (2) (1): 0dB, Stereo: On, Sub: Yes	30Hz	0dB	22	dB	-11 ≤ ± 2	-11 ≤ ± 1
	MEASUREMENT	L	C	R	LS	RS	SW	
	"50" Position	C/Ls/Rs/LFE -> L, R (3) (2): 0dB, Stereo: On, Sub: No	30Hz	0dB	22	dB	-6.5 ≤ ± 3	-6.5 ≤ ± 2
MEASUREMENT	L	C	R	LS	RS	SW		
13	Dynamic Range	Main Vol Level : "50" Position	1KHz	0dB	38	dB	-22 ≤ ± 2	-22 ≤ ± 1
	MEASUREMENT	L	C	R	LS	RS	SW	
	Sub-woofer : Yes	30Hz	0dB	18	dB	±1	±0.5	
	MEASUREMENT	L	C	R	LS	RS	SW	

● FM SECTION

Measuring methods in conformity with IEC standard 315

Measurements condition FM : Radio frequency = 98.1MHz, Audio frequency = 1kHz

Reference level = 1mV on (75ohms , 300ohms)

Deviation : MONO = $\pm 75\text{kHz}$, Stereo = $\pm 67.5\text{kHz} \pm 7.5\text{kHz}$ (A, K)

MONO = $\pm 40\text{kHz}$, Stereo = $\pm 40\text{kHz} \pm 7.5\text{kHz}$ (D/RDS)

Test Point : TP 1 = 90.1MHz, TP 2 = 98.1MHz, TP 3 = 106.1MHz (A, K)

TP 1 = 90.0MHz, TP 2 = 98.0MHz, TP 3 = 106.0MHz (D/RDS)

Filter = B.P.F at STEREO

NO	DESCRIPTION	UNIT	LIMIT L/R	NOMINAL L/R	VERSION	
1	TUNING RANGE	LOW ~ HIGH	MHz	87.5~107.9M	A, K	
		AUTO/Man.	kHz	200	"	
	STEP	LOW ~ HIGH	MHz	87.5~108.0M	D/RDS	
		AUTO/Man.	kHz	100/50	"	
2	USABLE SENSITIVITY S/N = 30dB	TP 1	dBf	≤ 17.2	≤ 14.2	A, K
		TP 2	dBf	≤ 17.2	≤ 14.2	"
		TP 3	dBf	≤ 17.2	≤ 14.2	"
	USABLE SENSITIVITY S/N = 26dB	TP 1	dBf	≤ 17.2	≤ 14.2	D/RDS
		TP 2	dBf	≤ 17.2	≤ 14.2	"
		TP 3	dBf	≤ 17.2	≤ 14.2	"
3	FULL LIMITING SENSE	OUTPUT = -3dB	dBf	≤ 15.2	≤ 12.2	
4	AUTO STOP LEVEL		dBf	31.2 ± 5	31.2 ± 3	
5	AUTO SCAN ERROR		kHz	± 20	± 25	A, K
			kHz	± 15	± 20	D/RDS
6	S/N RATIO IHF-A FILTER	MONO	dB	≥ 65	≥ 70	
		STEREO	dB	≥ 60	≥ 65	
7	TOTAL HARMONIC DISTORTION	MONO	%	≤ 0.5	≤ 0.3	
		STEREO	%	≤ 0.8	≤ 0.5	
8	50dB QUIETING SENS.	MONO	dBf	≤ 23.2	≤ 20.2	A, K
		STEREO	dBf	≤ 48.3	≤ 45.3	"
	46dB QUIETING SENS.	MONO	dBf	≤ 23.2	≤ 20.2	D/RDS
		STEREO	dBf	≤ 48.3	≤ 45.3	"
9	CHANNEL SEPARATION	100Hz	dB	≥ 35	≥ 40	A, K
		1kHz	dB	≥ 40	≥ 45	"
		10kHz	dB	≥ 30	≥ 35	"
		100Hz	dB	≥ 32	≥ 37	D/RDS
		1kHz	dB	≥ 37	≥ 42	"
		10kHz	dB	≥ 27	≥ 32	"
10	FREQUENCY RESPONSE AT $\pm 1.5\text{dB}$		Hz	20~12.5K	10~14K	
11	SPURIOUS RESPONSE		dB	≥ 70	≥ 80	A, K
			dB	≥ 80	≥ 90	D/RDS
12	IF REJECTION	TP 1	dB	≥ 70	≥ 80	
13	IMAGE REJECTION	TP 3	dB	≥ 60	≥ 65	A, K
		TP 3	dB	≥ 70	≥ 80	D/RDS
14	AM REJECTION RATIO		dB	≥ 47	≥ 52	
15	RF INTERMODULATION		dB			
16	CAPTURE RATIO		dB	≤ 2.5	≤ 2	
17	ALTERNATIVE CH SELECTIVITY	$\pm (400)\text{kHz}$	dB	≥ 42	≥ 47	
19	OUTPUT LEVEL MONO		mV	500 ± 150	500 ± 100	
20	RDS SENSITIVITY		dBf	≥ 40.2	≥ 38.2	RDS ONLY

● AM SECTION

Measuring methods in conformity with IEC standard 315

Measurements condition AM - MW : Radio frequency = 1000/999kHz, Audio frequency = 400Hz

LW : Radio frequency = 207kHz, Audio frequency = 400Hz

Reference level = 5mV/m, 10mV/m on 50ohms

Modulation = 30%

Test Point : MW TP1 = (594)kHz TP2 = (999)kHz TP3 = (1404)kHz (K, D/RDS)

Test Point : MW TP1 = (600)kHz TP2 = (1000)kHz TP3 = (1400)kHz (A)

LW TP1 = (162)kHz TP2 = (207)kHz TP3 = (252)kHz

NO	DESCRIPTION	UNIT	LIMIT L/R	NOMINAL L/R	VERSION
1	TUNING COVER RANGE	LOW ~ HIGH MW	kHz	522~1611	K, D/RDS
		LW	kHz		"
	STEP	AUTO/Man.	kHz	9	"
		LOW ~ HIGH MW	kHz	520~1710	A
		LW	kHz		"
		AUTO/Man.	kHz	10	"
2	USABLE SENSITIVITY S/N = 20dB	MW TP 1	uV/m	≤ 800	≤ 500
		TP 2	uV/m	≤ 800	≤ 500
		TP 3	uV/m	≤ 800	≤ 500
		LW TP 1	uV/m		
		TP 2	uV/m		
		TP 3	uV/m		
3	S/N RATIO	MW	dB	≥ 35	≥ 40
		LW	dB		
		MW	dB	≥ 40	≥ 45
		LW	dB		
4	TOTAL HARMONIC DISTORTION		%	≤ 2	≤ 1.0
			%	≤ 1.5	≤ 1.0
5	OVER LOAD DISTORTION 5mV 80% MOD		%	≤ 10	≤ 5
6	FREQUENCY RESPONSE at -6dB	MW	Hz	100~2K	80~2.2K
		LW	Hz		
7	SELECTIVITY 10kHz/9kHz	MW	dB	≥ 20	≥ 25
		LW	dB		
8	AGC FIGURE OF MERIT		dB	≥ 50	≥ 55
9	IMAGE REJECTION	MW = TP 3	dB	≥ 30	≥ 35
		LW = TP 3	dB		
10	WHISTLE MODULATION INPUT = 1mV/m	2IF	%	≤ 15	≤ 10
		3IF	%		
11	AUTO STOP LEVEL	MW	uV/m	800(±6dB)	800(±5dB)
		LW	uV/m		
12	TUNED LEVEL	MW	uV/m	800(±6dB)	800(±5dB)
		LW	uV/m		
13	OUTPUT LEVEL		mV	120±50	120±30
			mV	150±50	150±30

● GENERAL

Power consumption A : 2.3A, D : 550W, K : 450W

Power supplies A : AC 120V, 50Hz (A Version)

D : AC 220V, 50Hz (D/RDS Version)

K : AC 220V, 60Hz (K Version)

Dimensions (W×H×D) 440×125×300mm

17-5/16×4-15/16×1-1/8inches

Weight (Net) 10.5kg

NOTES

BLOCK DIAGRAM

Model No. : R-925R/R-925RDS

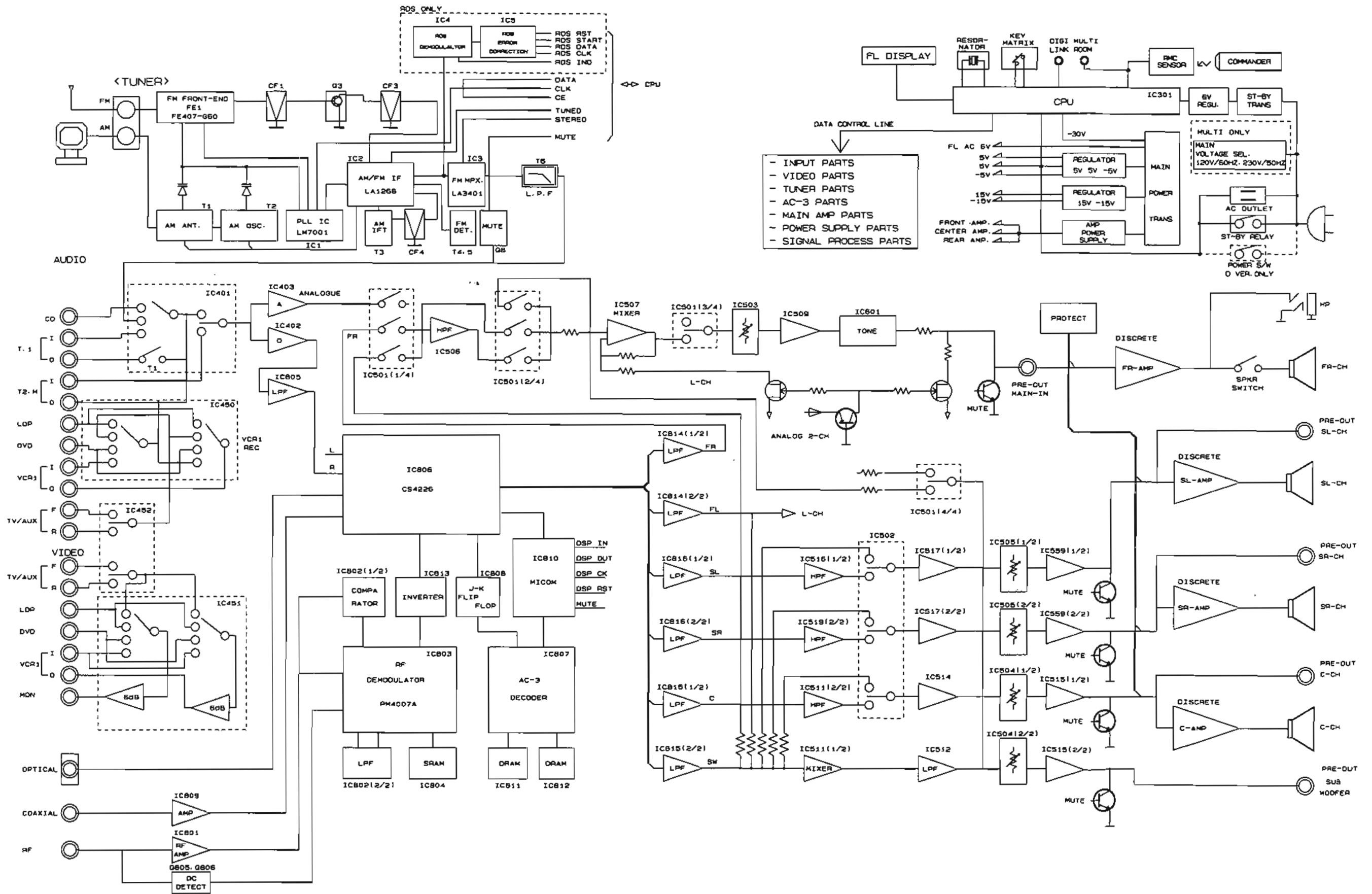

WIRING DIAGRAM

Model No. : R-925R/R-925RI

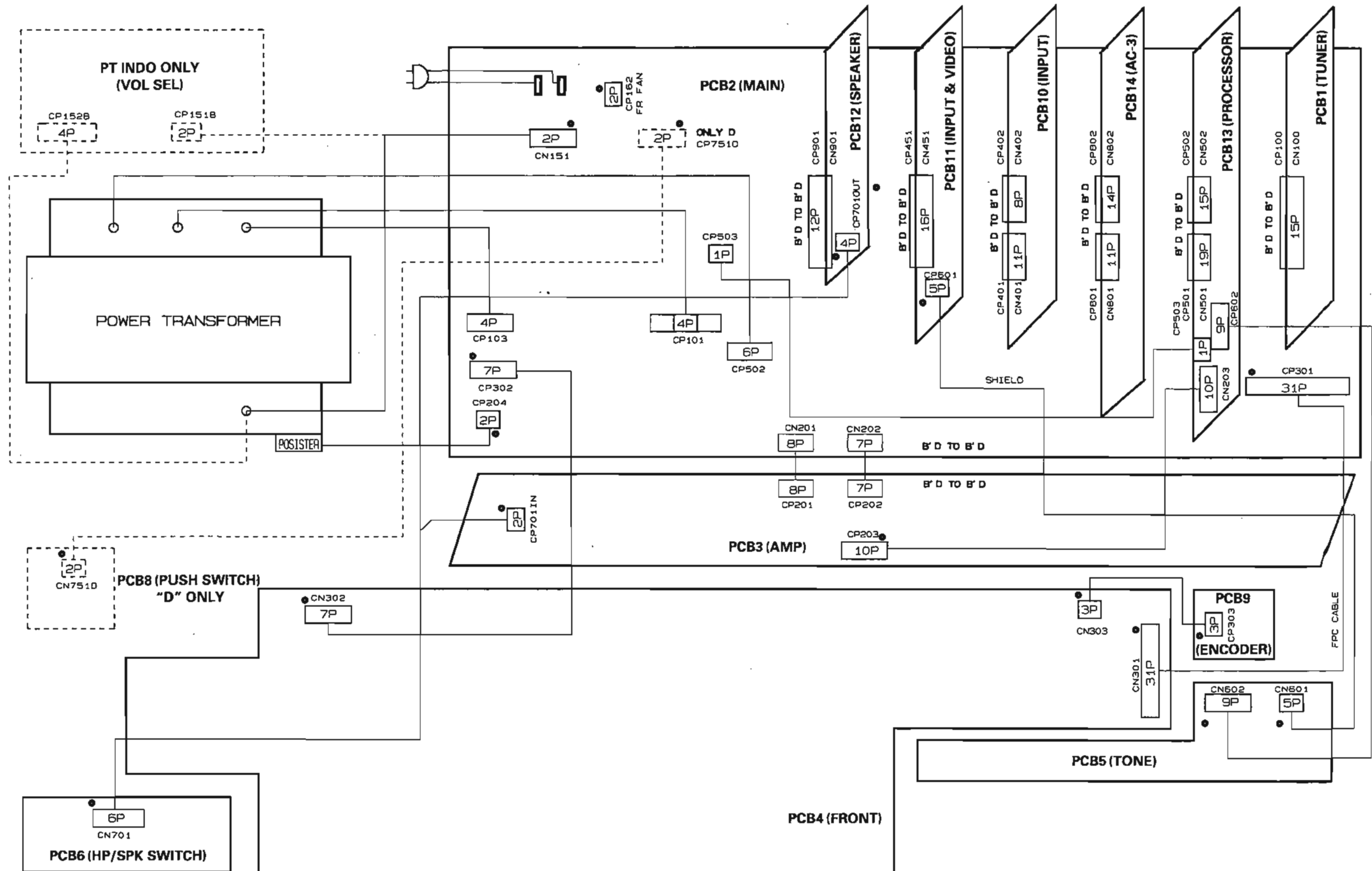

CIRCUIT DESCRIPTION

IC301 : CXP-82852-114Q, DWP427

1. Pin Description

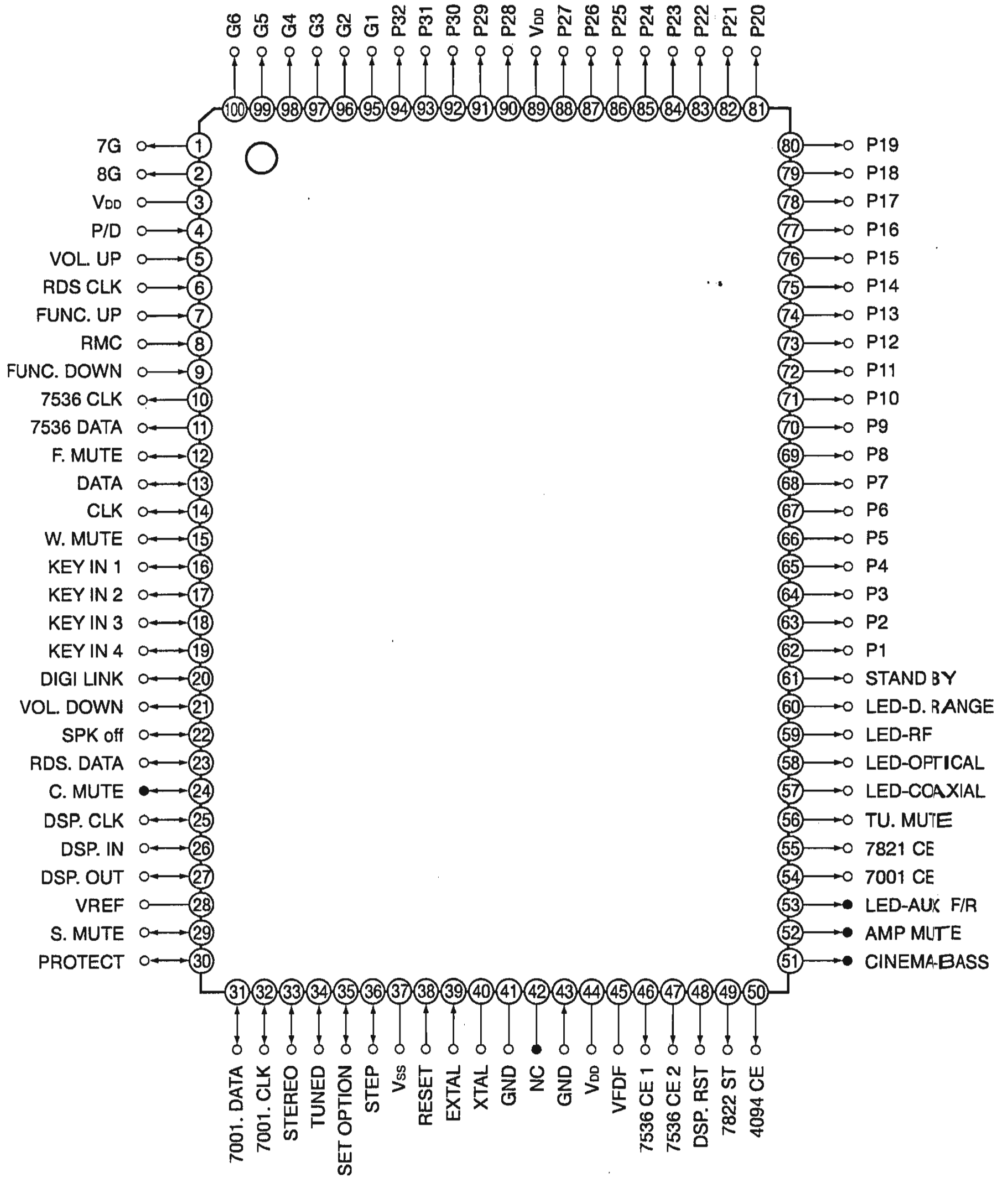

2. Main CPU Pin Functions

Pin No.	Symbol	Description
1~2	7G~8G	Grid signal output for FIP.
3	VDD	+5V power supply.
4	P/D	Input for power down.
5	VOL. UP	Input for main volume up.
6	RDS CLK	CLOCK signal output for TDA7330.
7	FUNC. UP	Input for main function up.
8	RMC	Input for remocon data.
9	FUNC. DOWN	Input for main function down.
10	7536CLK	CLOCK signal output for LC7536
11	7536DATA	DATA signal output for LC7536
12	F. MUTE	Output for front channel mute.(At "H", it is active.)
13	DATA	DATA signal output for LC7821 and LC7822.
14	CLK	CLOCK signal output for LC7821 and LC7822.
15	W. MUTE	Output for subwoofer mute.(At "H", it is active.)
16~19	KEY IN1~4.	Data input for key scan.
20	DIGI LINK	Input/Output for controlling digi-link III
21	VOL. DOWN	Input for main volume down.
22	SPK OFF	Input for detecting "SPEAKER SWITCH IS OFF" condition.
23	RDS. DATA	Input for RDS data of TDA7330.
24	C. MUTE	Output for center channel mute.(At "H", it is active.)
25	DSP. CLK	CLOCK signal input from IC810(uPD78044, pin 9).
26	DSP. IN	DATA signal input from IC810(uPD78044, pin 11).
27	DSP. OUT	DATA signal output to IC810(uPD78044, pin 10).
28	VREF	Reference voltage.(Connected to +5V, Not VDD.)
29	S. MUTE	Output for surround channel mute.(At "H", it is active.)
30	PROTECT	Input for detecting "PROTECTION" condition.
31	7001. DATA	DATA signal output for LM7001.
32	7001. CLK	CLOCK signal output for LM7001.
33	STEREO	Input for detecting "STEREO" condition.
34	TUNED	Input for detecting "TUNED" condition.(At "L", it is active.)
35	SET OPTION	Input for selecting set.(5V:RDS Receiver, 0V:Receiver.)
36	STEP	Input for selecting the frequency ranges steps of FM and AM.
37	VSS	This pin provides the ground potential.
38	RESET	Input for resetting the CPU.(At "L", it is active.)
39	EXTAL	Input for 10MHz crystal oscillator.
40	XTAL	Output for 10MHz crystal oscillator.
41	G	Ground.
42		Not used!
43	G	Ground.
44	VDD	+5V power supply.
45	VDFD	-30V power supply for FIP.
46	7536CE1	Chip enable signal output to LC7536.(Front channel electric volume)
47	7536CE2	Chip enable signal output to LC7536.(Center, rear and woofer CH. electric vol.)
48	DSP. RST	RESET signal output to IC810(uPD78044, pin 17).
49	7822ST	Chip enable signal output to LC7822.
50	4094CE	LC7536 CHIP ENABLE(FRONT VR).
51	CINEMA-BASS	Output signal for Cinema-Bass function. (High Active)
52	AMP MUTE	Output for main mute.(At "H", it is active.)
53	LED-AUX F/R	Output to drive AUX FRONT/REAR LED.(At "H"-Front, "L"-Rear.)
54	7001CE	Chip enable signal output to LM7001.
55	7821CE	
56	TU. MUTE	Output for tuner mute.(At "H", it is active.)
57	LED-COAXIAL	Output to drive COAXIAL LED.(At "H", it is active.)
58	LED-OPTICAL	Output to drive OPTICAL LED.(At "H", it is active.)
59	LED-RF	Output to drive RF LED.(At "H", it is active.)
60	LED-D.RANGE	Output to drive Dynamic Range LED.(At "H", it is active.)
61	STAND BY	Output to drive Power relay & Stand-by LED.(At "H", it is active.)
62~70	P1~P9	Segment signal output for FIP.
71~80	P10~P19	Segment signal output for FIP and data output for key scan.
81~88	P20~P27	Segment signal output for FIP.
89	VDD	+5V power supply.
90~94	P28~P32	Segment signal output for FIP.
95~100	1G~6G	Grid signal output for FIP.

3. Block Diagram

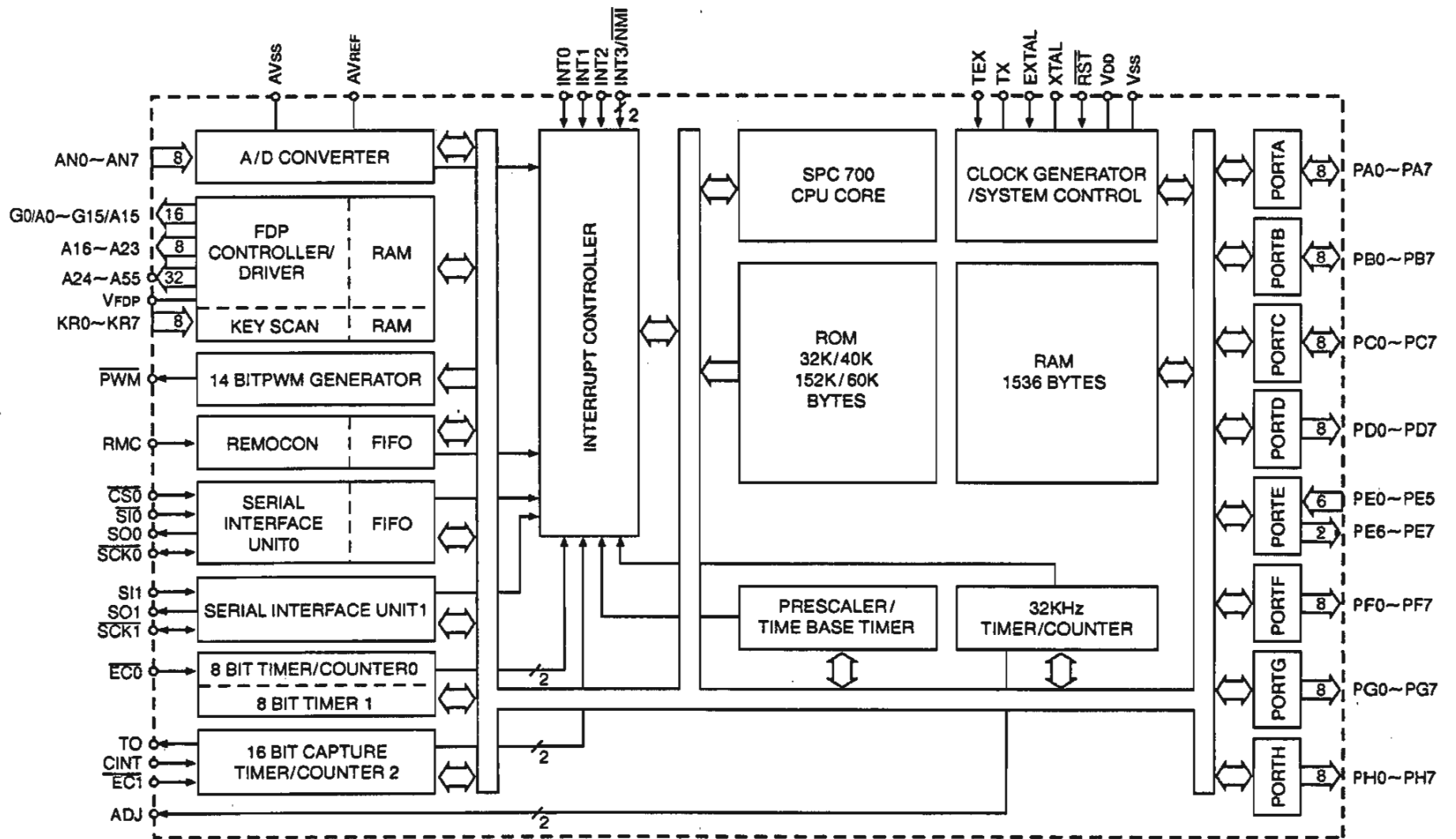

4. Key Matrix

		KEY CHECK									
		KEY SCAN 0	KEY SCAN 1	KEY SCAN 2	KEY SCAN 3	KEY SCAN 4	KEY SCAN 5	KEY SCAN 6	KEY SCAN 7	KEY SCAN 8	KEY SCAN 9
		PIN 71	PIN 72	PIN 73	PIN 74	PIN 75	PIN 76	PIN 77	PIN 78	PIN 79	PIN 80
KEY IN1	SLEEP/ PIN 16	ST-BY	SEARCH	DSP	4	7	MEMORY	WOOFER	BAND	CENTER	DYNAMIC
KEY IN2	AC-3 PIN 17	ST-BY	EON TA	PRO- LOGIC	3	8	WOOFER DOWN	FM MODE	PTY SELECT	CENTER LEVEL UP	VCR1 REC
KEY IN3	1 PIN 18	ST-BY	EON PTY	TUNE DOWN	2	9	0	REAR LEVEL DW	TURN UP		TAPE2 MONITOR
KEY IN4	POWER PIN 19	(ST-BY)	DISPLAY	OFF	5	6	FREQUENCY	REAR LEVEL UP	CINEMA BASE	SPKR MODE	VIDEO LABELS

IC810 : uPD78044**2-1.Sub CPU Pin Functions**

Pin No.	Symbol	Description
1~7		Not used!
8	VDD	+5V power supply.
9	SCK0	CLOCK signal output to IC301(CXP82852, pin 25).
10	SB1	DATA signal input from IC301(CXP82852, pin 27)
11	SB0	DATA signal output to IC301(CXP82852, pin 26)
12~13		Not used!
14	SCK1	CLOCK signal output to IC807(MC56009) and IC806(CS4226).
15	SO1	DATA signal output to IC807(MC56009) and IC806(CS4226).
16	SI1	DATA signal input from IC807(MC56009) and IC806(CS4226).
17	RESET	RESET signal input from IC301(CXP82852, pin 50)
18	P74	Ground.
19	P73	Ground.
20	AVSS	Ground.
21	AN17	RESET signal output to IC806(CS4226).
22	AN16	Not used!
23	AN15	STROBE signal output to IC806(CS4226).
24	AN14	Not used!
25	AN13	Output for all channel mute.(At "L", it is active.)
26~27		Not used!
28	AN10	Sampling rate control port.(At "H", it is 48 kHz mode. At "L", it is 44.1 kHz mode.)
29	AVDD	+5V power supply.
30	AVREF	+5V power supply.
31	XT1	Ground.
32	XT2	Not used!
33	VSS	This pin provides the ground potential.
34	X1	Input for 4.19MHz crystal oscillator.
35	X2	Output for 4.19MHz crystal oscillator.
36	P37	Output for DSP mode.(At "H", it is active.)
37	BUZ	General purpose I/O pin. This pin is connected pin 39 and pin 40
38	PCL	IC803(PM4007) OSC control port.(At "H", it is OSC-OFF. At "L", it is OSC-ON.)
39	TI2	This pin is connected pin 37 and pin 40
40	TI1	This pin is connected pin 37 and pin 39
41	TO2	Chip enable signal output to IC807(MC56009).
42	TO1	RESET signal output to IC807(MC56009).
43	TO0	Host request port from IC807(MC56009).
44	CI0	Test tone retry.(At "L", it is active.)
45	INTP2	Input for detecting "OPTICAL INPUT".(At "L", it is active.)
46	INP1	Input for detecting "COAXIAL INPUT".(At "L", it is active.)
47	TI0	Input for detecting "AC-3 DATA" and "PCM DATA".(At "L", it is active.)
48	IC	Ground.
49~51		Not used!
52	VDD	+5V power supply.
53~70		Not used!
71	VLOAD	Ground.
72~80		Not used!

IC807 : DSP56009 ⇒ SIGNAL/CONNECTION DESCRIPTIONS

3-1.Pin Discription

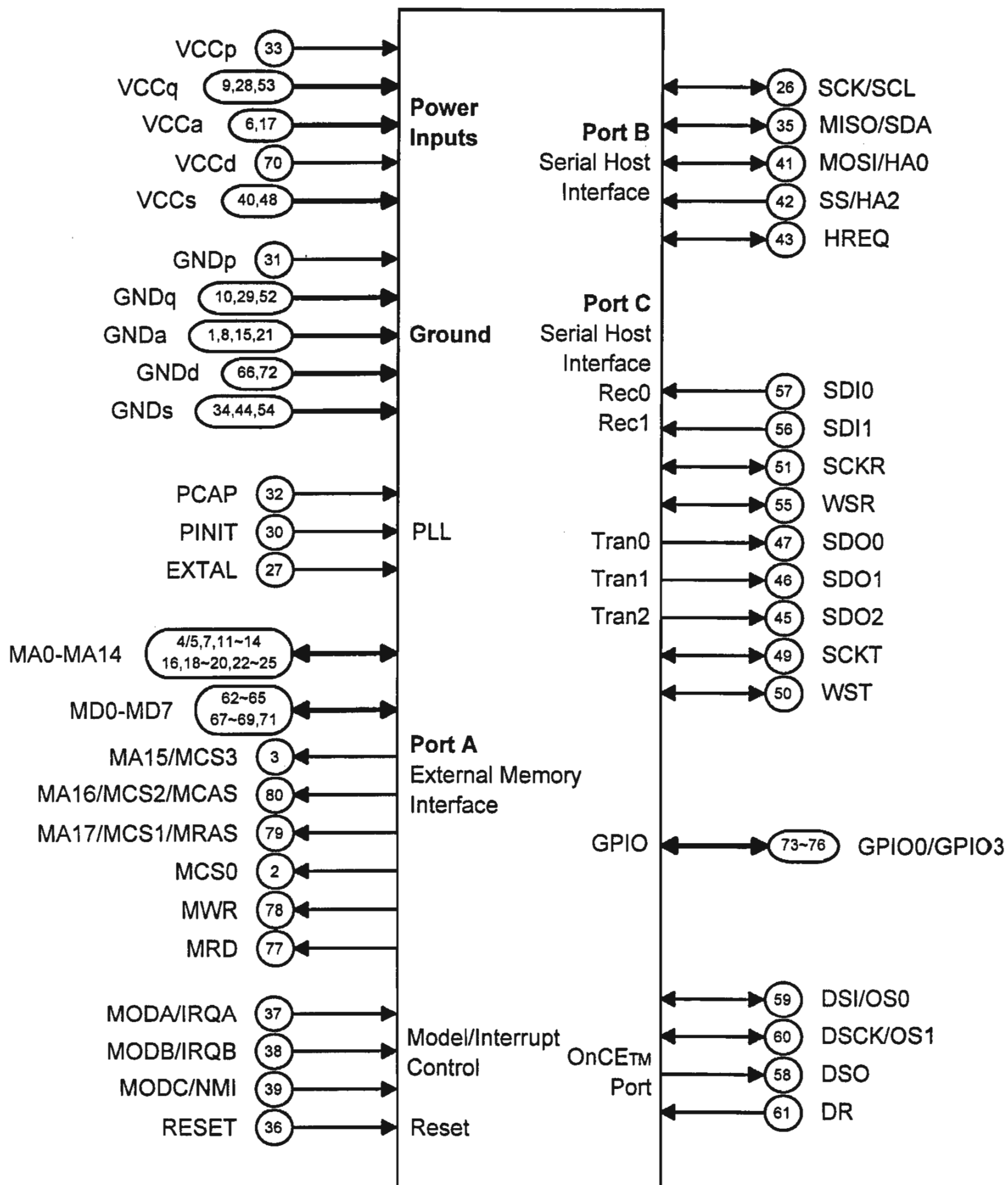

3-2. Pin Function

☞ SIGNAL GROUPINGS

Table 1-1 Functional Group Signal Allocations

Functional Group	Number of Signals	Detailed Description
Power (VCC)	9	Table 1-2
Ground (GND)	13	Table 1-3
Phase Lock Loop (PLL)	3	Table 1-4
External Memory Interface (EMI)	29	Table 1-5 and Table 1-6
Interrupt and Mode Control	4	Table 1-7
Serial Host Interface (SHI)	5	Table 1-8
Serial Audio Interface (SAI)	9	Table 1-9 and Table 1-10
General Purpose Input/Output (GPIO)	4	Table 1-11
On-Chip Emulation (OnCE) port	4	Table 1-12
Total	80	

☞ POWER

Table 1-2 Power Inputs

Power Name	Description
Vccp	PLL Power - Vccp provides isolated power for the Phase Lock Loop (PLL).
Vccq	Quiet Power - Vccq provides isolated power for the internal processing logic.
Vcca	Address Bus Power - Vcca provides isolated power for sections of the address bus I/O drivers.
Vccd	Data Bus Power - Vccd provides isolated power for sections of the data bus I/O drivers.
Vccs	Serial Interface Power - Vccs provides isolated power for the SHI and SAI.

☞ GROUND

Table 1-3 Grounds

Ground Name	Description
GNDp	PLL Ground - GNDp is ground dedicated for PLL use.
GNDq	Quiet Ground - GNDq provides isolated ground for the internal processing logic.
GNDa	Address Bus Ground - GNDa provides isolated ground for sections of the address bus I/O drivers.
GNDd	Data Bus Ground - GNDd provides isolated ground for sections of the data bus I/O drivers.
GNDs	Serial Interface Ground - GNDs provides isolated ground for the SHI and SAI.

CLOCK AND PLL SIGNALS

Table 1-4 Clock and PLL Signals

Signal Name	Signal Type	State during Reset	Signal Description
EXTAL	Input	Input	External Clock/Crystal - This input should be connected to an external clock source.
PCAP	Input	Input	PLL Filter Capacitor - This input is used to connect a high-quality (high "Q" factor) external capacitor needed for the PLL filter.
PINIT	Input	Input	PLL Initialization (PINIT) - During the assertion of hardware reset, the value on the PINIT line is written into the PEN bit of the PCTL register.

EXTERNAL MEMORY INTERFACE (EMI)

Table 1-5 External Memory Interface (EMI) Signals

Signal Name	Signal Type	State during Reset	Signal Description
MA0 - MA14	Output	Table 1-6	Memory Address Lines 0-14 - The MA0-MA10 lines provide the multiplexed row/column addresses for DRAM accesses.
MA15	Output	Table 1-6	Memory Address Line 15 (MA15) - This line functions as the non-multiplexed address line 15.
MCS3			Memory Chip Select 3 (MCS3) - For SRAM accesses, this line functions as memory chip select 3.
MA16	Output	Table 1-6	Memory Address Line 16 (MA16) - This line functions as the non-multiplexed address line 16 or as memory chip select 2 for SRAM accesses.
MCS2			Memory Chip Select 2 (MCS2) - For SRAM access, this line functions as memory chip select 2.
MCAS			Memory Column Address Strobe (MCAS) - This line functions as the Memory Column Address Strobe (MCAS) during DRAM accesses.
MA17	Output	Table 1-6	Memory Address Line 17 (MA17) - This line functions as the non-multiplexed address line 17.
MCS1			Memory Chip Select 1 (MCS1) - This line functions as chip select 1 for SRAM accesses.
MRAS			Memory Row Address Strobe (MRAS) - This line also functions as the Memory Row Address Strobe during DRAM accesses.
MCS0	Output	Table 1-6	Memory Chip Select 0 - This line functions as memory chip select 0 for SRAM accesses.
MWR	Output	Table 1-6	Memory Write Strobe - This line is asserted when writing to external memory.
MRD	Output	Table 1-6	Memory Read Strobe - This line is asserted when reading external memory.
MD0 - MD7	Bidi-rectional	Tri-stated	Data Bus - These signals provide the bidirectional data bus for EMI accesses.

Table 1-6 EMI States during Reset and Stop States

Signal	Operating Mode			
	Hardware Reset	Software Reset	Individual Reset	Stop Mode
MA0 - MA14	Driven High	Previous State	Previous State	Previous State
MA15	Driven High	Driven High	Previous State	Previous State
MCS3	Driven High	Driven High	Driven High	Driven High
MA16	Driven High	Driven High	Previous State	Previous State
MCS2	Driven High	Driven High	Driven High	Driven High
MCAS:				
DRAM refresh disabled	Driven High	Driven High	Driven High	Driven High
DRAM refresh enabled	Driven High	Driven High	Driven High	Driven High
MA17	Driven High	Driven High	Previous State	Previous State
MCS1	Driven High	Driven High	Driven High	Driven High
MRAS:				
DRAM refresh disabled	Driven High	Driven High	Driven High	Driven High
DRAM refresh enabled	Driven High	Driven High	Driven High	Driven High
MCS0	Driven High	Driven High	Driven High	Driven High
MWR	Driven High	Driven High	Driven High	Driven High
MRD	Driven High	Driven High	Driven High	Driven High

INTERRUPT AND MODE CONTROL

Table 1-7 Interrupt and Mode Control Signals

Signal Name	Signal Type	State during Reset	Signal Description
MODA	Input	Input (MODA)	<p>Mode Select A - This input signal has three functions:</p> <ul style="list-style-type: none"> to work with the MODB and MODC signals to select the DSP's initial operating mode, to allow an external device to request a DSP interrupt after internal synchronization, and to turn on the internal clock generator when the DSP is in the Stop processing state, causing the DSP to resume processing. <p>MODA is read and internally latched in the DSP when the processor exits the Reset state.</p> <p>External Interrupt Request A (IRQA) - The IRQA input is a synchronized external interrupt request.</p>
IRQA			
MODB	Input	Input (MODB)	<p>Mode Select B - This input signal has two functions:</p> <ul style="list-style-type: none"> to work with the MODA and MODC signals to select the DSP's initial operating mode, and to allow an external device to request a DSP interrupt after internal synchronization. <p>MODB is read and internally latched in the DSP when the processor exits the Reset state.</p> <p>External Interrupt Request B (IRQB) - The IRQB input is a synchronized external interrupt request.</p>
IRQB			

Table 1-7 Interrupt and Mode Control Signals

Signal Name	Signal Type	State during Reset	Signal Description
MODC	Input, edge-triggered	Input (MODC)	<p>Mode Select C - This input signal has two functions:</p> <ul style="list-style-type: none"> to work with the MODA and MODB signals to select the DSP's initial operating mode, and to allow an external device to request a DSP interrupt after internal synchronization. <p>MODC is read and internally latched in the DSP when the processor exits the Reset state.</p> <p>Non-Maskable Interrupt Request - The NMI input is a negative-edge-triggered external interrupt request.</p>
NMI			
RESET	input	active	RESET - This input causes a direct hardware reset of the processor.

SERIAL HOST INTERFACE (SHI)

Table 1-8 Serial Host Interface (SHI) signals

Signal Name	Signal Type	State during Reset	Signal Description
SCK	Input or Output	Tri-stated	<p>SPI Serial Clock (SCK) - The SCK signal is an output when the SPI is configured as a master, and a Schmitt-trigger input when the SPI is configured as a slave.</p> <p>I² C Serial Clock (SCL) - SCL carries the clock for bus transactions in the I² C mode.</p>
SCL	Input or Output		
MISO	Input or Output	Tri-stated	<p>SPI Master-In-Slave-Out (MISO) - When the SPI is configured as a master, MISO is the master data input line.</p> <p>I² C Serial Data and Acknowledge (SDA) - In I² C mode, SDA is a Schmitt-trigger input when receiving and an open-drain output when transmitting.</p>
SDA	Input or Output		
MOSI	Input or Output	Tri-stated	<p>SPI Master-Out-Slave-In (MOSI) - When the SPI is configured as a master, MOSI is the master data output line.</p> <p>I² C Slave Address 0 (HA0) - This signal uses a Schmitt-trigger input when configured for the I² C mode.</p>
HA0	Input		
SS	Input	Tri-stated	<p>SPI Slave Select (SS) - This signal is an active low Schmitt-trigger input when configured for the SPI mode.</p> <p>I² C Slave Address 2 (HA2) - This signal uses a Schmitt-trigger input when configured for the I² C mode.</p>
HA2	Input		
HREQ	Input or Output	Tri-stated	Host Request - This signal is an active low Schmitt-trigger input when configured for the Master mode, but an active low output when configured for the Slave mode.

👉 SERIAL AUDIO INTERFACE (SAI)

① SAI Receiver Section

Table 1-9 Serial Audio Interface (SAI) Receiver signals

Signal Name	Signal Type	State during Reset	Signal Description
SDI0	Input	Tri-stated	Serial Data Input 0 - While in the high impedance state, the internal input buffer is disconnected from the pin and no external pull-up is necessary.
SDI1	Input	Tri-stated	Serial Data Input 1 - While in the high impedance state, the internal input buffer is disconnected from the pin and no external pull-up is necessary.
SCKR	Input or Output	Tri-stated	Receive Serial Clock - SCKR is an output if the receiver section is programmed as a master, and a Schmitt-trigger input if programmed as a slave.
WSR	Input or Output	Tri-stated	Word Select Receive (WSR) - WSR is an output if the receiver section is configured as a master, and a Schmitt-trigger input if configured as a slave.

② SAI Transmitter Section

Table 1-10 Serial Audio Interface (SAI) Transmitter signals

Signal Name	Signal Type	State during Reset	Signal Description
SDO0	Output	Driven High	Serial Data Output 0 (SDO0) - SDO0 is the serial output for transmitter 0.
SDO1	Output	Driven High	Serial Data Output 1 (SDO1) - SDO1 is the serial output for transmitter 1.
SDO2	Output	Driven High	Serial Data Output 2 (SDO2) - SDO2 is the serial output for transmitter 2.
SCKT	Input or Output	Tri-stated	Serial Clock Transmit (SCKT) - This signal provides the clock for the SAI.
WST	Input or Output	Tri-stated	Word Select Transmit (WST) - WST is an output if the transmit section is programmed as a master, and a Schmitt-trigger input if it is programmed as a slave.

☞ GENERAL PURPOSE I/O

Table 1-11 General Purpose I/O (GPIO) Signals

Signal Name	Signal Type	State during Reset	Signal Description
GPIO0- GPIO3	Standard Output, Open-drain Output, or Input	Disconnected	GPIO lines can be used for control and handshake functions between the DSP and external circuitry.

☞ ON-CHIP EMULATION (OnCE™) PORT

Table 1-12 On-Chip Emulation Port Signals

Signal Name	Signal Type	State during Reset	Signal Description
DSI	Input	Output, Driven Low	Debug Serial Input (DSI) - The DSI signal is the signal through which serial data or commands are provided to the OnCE port controller.
OS0	Output		Operating Status 0 (OS0) - When the DSP is not in the Debug mode, the OS0 signal provides information about the DSP status if it is an output and used in conjunction with the OS1 signal.
DSCK	Input	Output, Driven Low	Debug Serial Clock (DSCK) - The DSCK/OS1 signal, when an input, is the signal through which the serial clock is supplied to the OnCE port.
OS1	Output		Operating Status 1 (OS1) - If the OS1 signal is an output and used in conjunction with the OS0 signal, it provides information about the DSP status when the DSP is not in the Debug mode.
DSO	Output	Driven High	Debug Serial Output (DSO) - The DSO line provides the data contained in one of the OnCE port controller registers as specified by the last command received from the command controller.
DR	Input	Input	Debug Request (DR) - The debug request input provides a means of entering the Debug mode of operation.

NOTES

ALIGNMENT PROCEDURES

TUNER

1. Equipment Required

- AM Standard Signal Generator (AM SSG)
- Oscilloscope
- AC Voltmeter
- FM Standard Signal Generator (FM SSG)
- Stereo Modulator
- Audio Generator
- Distortion Meter
- DC Voltmeter
- Frequency Counter

Note : Disconnect external FM antenna prior to alignment.

2. Alignment

2-1. Alignment and Test Point

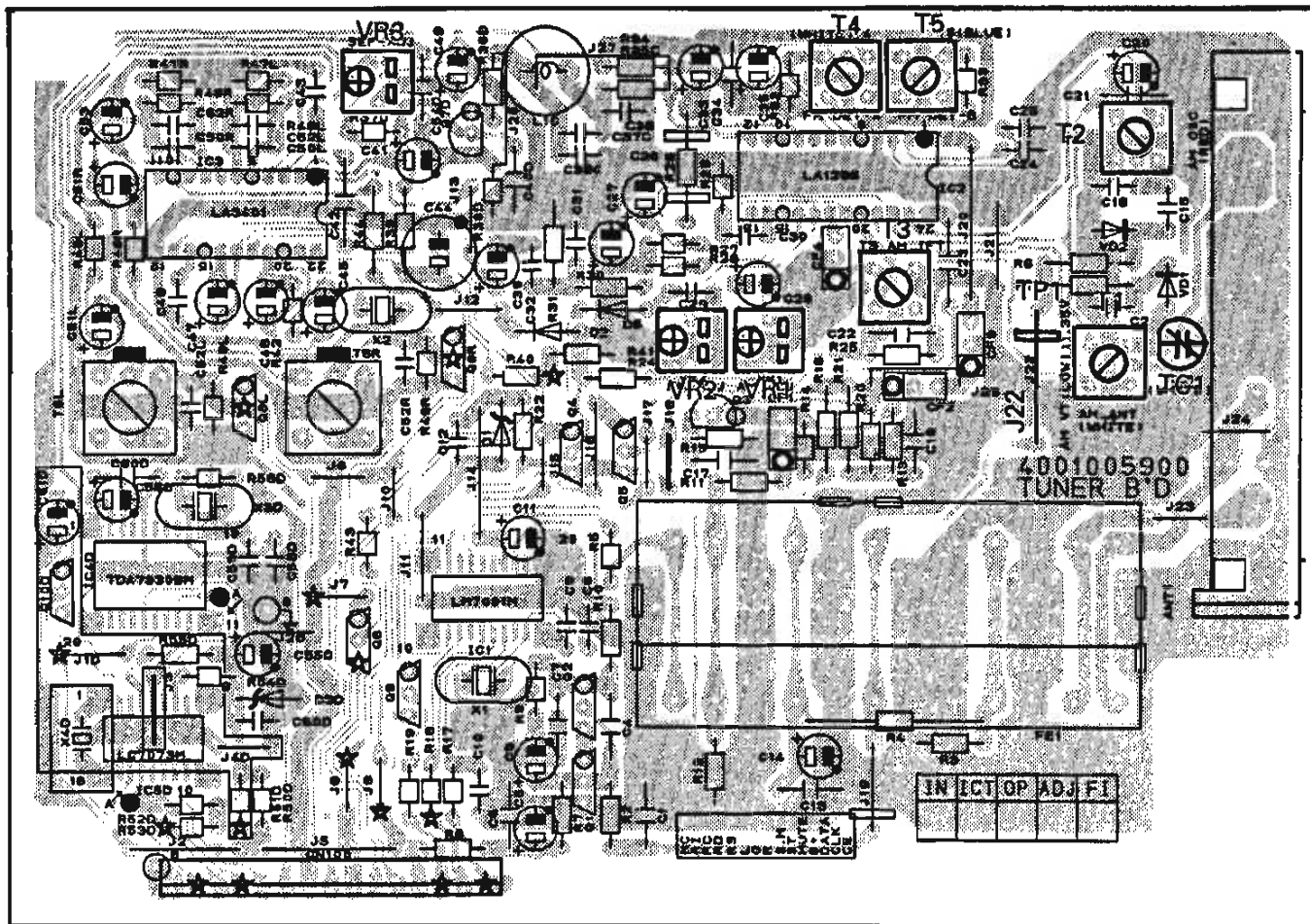

2-2. AM Alignment

- Output of signal generator should not be greater than necessary to obtain an optimum output reading.
- Signal generator modulation : 30 %
- RF signal frequency : 400 Hz
- Switch : Press the BAND button to AM

Step	Subject	Signal Generator Frequency	Set Frequency Setting	Equipment Connection	Adjustment Point	Adjust for
1	Tuning Voltage	520kHz (522kHz)	520kHz 1) (522kHz)	DC Voltmeter to J22 (TP1)	T2 AM OSC(R)	DC 1.5V ± 0.2 V
2	USABLE sensitivity	600kHz (594kHz)	600kHz 1) (594kHz)	AC voltmeter and oscilloscope to speaker terminal of L or R channel	T 1 MW ANT(W)	Maximize audio output
		1400kHz (1404kHz)	1400kHz 2) (1404kHz)		TC1	
* Feed signal should be fed to loop antenna through the test loop antenna 60 cm distant from the appliance. * Repeat the step 1) and 2) until no further improvement occurs.						

3	IF	1000kHz (999kHz)	1000kHz (999kHz)	Ac voltmeter and oscilloscope to speaker terminal of L or R channel	T3 AM IFT	Maximize audio output
4	Tuned Level	1000kHz(999kHz) 800 μ V/m	1000kHz (999kHz)		VR1	"Tuned" flag in the FL display light on

3-3. FM Alignment

- Output of signal generator should not be greater than necessary to obtain an optimum output reading.
- Signal generator deviation : USA/Canada/Korea : 75kHz, Europe : 40kHz
- RF signal frequency : 1 kHz
- Switch : Press the BAND button to FM and the FM MODE button to MONO

Step	Subject	Signal Generator Frequency	Set Frequency Setting	Equipment Connection	Adjustment Point	Adjust for
1	Tuning Band Width	98.1MHz (98MHz)	98.1MHz (98MHz)	DC Voltmeter to R26(PCB1)	T4	Zero reading on DC Voltmeter
2	THD	98.1MHz (98MHz)	98.1MHz (98MHz)	Distortion meter to TAPE OUT jack of L or R channel	T5	Minimize distortion
3	Tuned Level	98.1MHz(98MHz) SSG output level: 10 μ V/m	98.1MHz (98MHz)		VR2	"Tuned" flag in the FL display light on

3-4. MPX Alignment

- Signal generator frequency : 98 MHz
- Signal generator deviation : USA : 75kHz, Europe : 40kHz
- RF signal frequency : 1 kHz
- Signal generator output level : 1000 μ V/m
- Connect signal generator to FM antenna terminal through FM dummy antenna (75 Ω)
- Switch : Press the BAND button to FM and the FM MODE button to STEREO

Step	Subject	19kHz Modulation Level	Set Generator Setting	Equipment Connection	Adjustment Point	Adjust for
1	Separation R \rightarrow L	8% Modulation	Pilot on	AC voltmeter to speaker terminal of R channel	VR3	Set AC voltmeter to 0 dB
				AC voltmeter to speaker terminal of L channel		AC voltmeter reading should be at least 40 dB below
2	Separation L \rightarrow R	8% Modulation	Pilot on	AC voltmeter to speaker terminal of L channel	VR3	Set AC voltmeter to 0 dB
				AC voltmeter to speaker terminal of R channel		AC voltmeter reading should be at least 40 dB below

If you could not obtain -40 dB readings in steps 1 and 2, readjust VR3 until you obtain -40 dB readings.
Nominal is -45 dB. (Europe : Nominal -42 dB, Limit -37 dB)

4. Equipment Connection

4-1. AM Alignment Connection

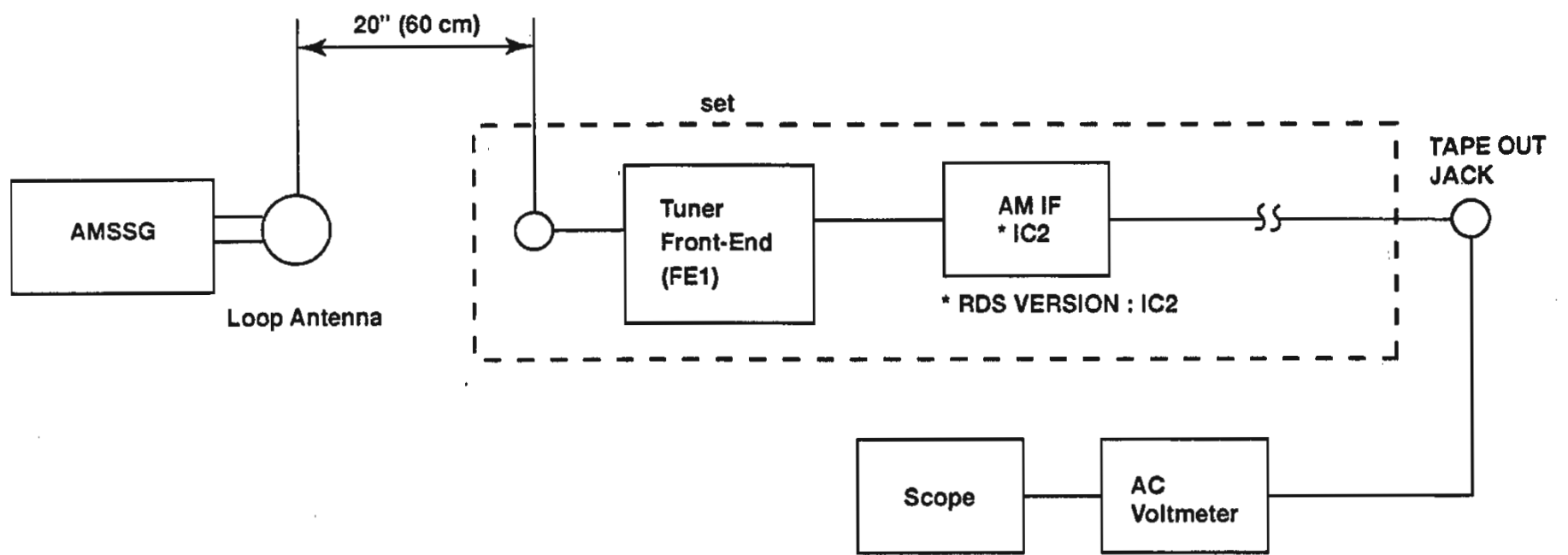

4-2. FM Dummy Antenna

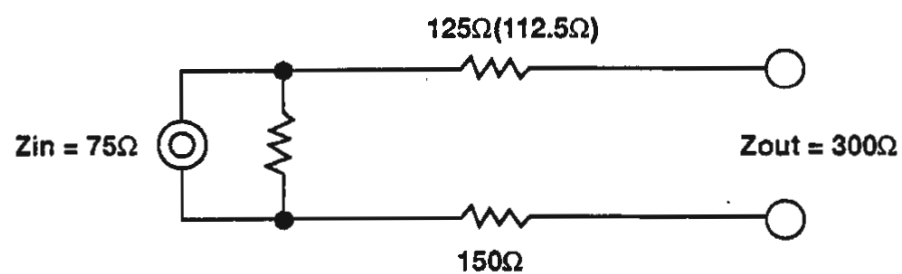

FM Dummy Antenna to 300Ω Antenna terminal of system.

4-3. FM RF/IF and MPX Alignment Connection

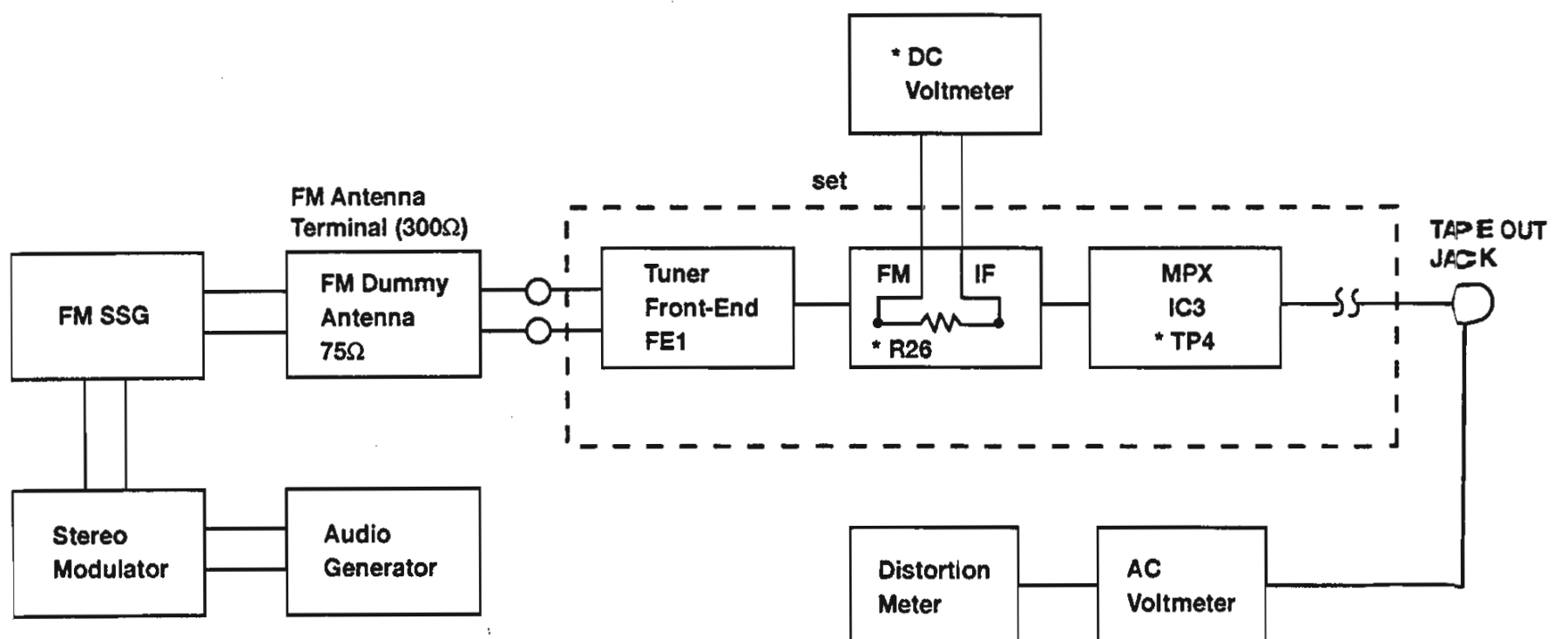

TROUBLESHOOTING

Symptom	Cause and Remedy
Receiver inoperative. (FL indicator does not light.)	A) Faulty AC power cord. Replace. B) Defective the power switch. Replace. C) Broken wire in the power transformer. Replace. D) Blown fuse. Replace the fuse.
Fuse blows when power is turned on.	A) Defective power transformer. Replace. B) Short on the primary or secondary of the transformer circuitry. Repair the short. C) Damaged rectifier D105-D112 or damaged transistor Q215L/R/C/SL, Q216L/R/C/SL. D) Short circuit in the amplifier circuit. Repair the shorted component(s) in the amplifier circuit.
Power indicator lights but no sound from both channels.	A) Defective in transistor Q215L/R, Q216L/R on the AMP302 Board. B) Pulled out of correct speaker switch.
One channel does not work when volume is at maximum with a test signal applied to the center terminal of volume control of the dead channels.	A) Defective in transistor Q215L/R or Q216L/R on the AMP302 Board. Replace the defect. B) Break in copper foil of printed circuit board. Repair the defect. C) Short in speaker output terminal. Repair or replace.
Speaker works normally but headphones inoperative.	A) Headphone plug does not match with jack. Replace the jack. B) Defective resistor R701L/R. Replace.
FM inoperative	A) Defective front-end (FE). Replace. B) Defective FM switch. Replace the switch. C) Defective transistor Q3 and ICS (IC2,IC3). Replace the defective transistor or IC(s). D) Defective coil T4, T5. Replace the coil(s). E) Defective lead-in. Repair or replace the lead-in. F) Ceramic filters CF1, CF3 defective. Replace the defective ceramic filter(s).
Poor multiplex separation.	A) Improper adjustment. Readjust VR3. B) IC3 defective. Replace. C) Variable resistor VR3 defective. Replace the variable resistor.
FM volume is insufficient.	A) If volume from both L and R channels is not loud enough : Front end section defective. Faulty IC2, Coil T4 or T5. If sound of one channel is not loud enough : Defective VR3.

Symptom	Cause and Remedy
STEREO indicator does not light.	A) Defective indicator in FL. Replace. B) Improper adjustment of VR2 of tuner board. Make readjustment. C) Defective IC2. Replace the defective component.
FM Mono has no effect.	A) Defective FM MODE switch. Replace.
AM inoperative.	A) Damaged IC2 of tuner Board. Replace. B) Defective T1, T2, T3 or CF4 of Tuner Board. Replace the defective component(s). D) Defective varicap diodes VD1 or VD2. Replace varicap diodes(s). E) Damaged AM loop antenna. Repair or replace.
Bass control has no effect.	A) Variable resistor BASS defective. Replace.
Treble control has no effect.	A) Variable resistor TREBLE defective.
Auto tune inoperative. (UP/DOWN)	A) Poor contact in Up/Down key. Repair or replace. B) Defective IC301. Replace. C) Defective tuner Circuit components. Replace. D) In case of FM only, improper adjustment of FM front-end. Readjust.
Manual tune inoperative. (UP/DOWN) (AM or FM)	A) Poor contact in Up/Down key. B) Defective IC301. Replace.
Memory setting inoperative.	A) Poor contact in memory keys 1-10. Replace the defective component. B) Defective IC301. Replace the defective component.
FL inoperative.	A) FL defective. Replace. B) Defective IC301. Replace. C) Defective X-TAL 301. Replace.
Noisy volume control.	A) Defective volume. Replace.
Remote Control Unit inoperative.	A) Weak battery. Replace. B) Defective. Replace. C) Defective IC301 (FRONT Board) Replace.

MECHANICAL PARTS LIST

*Parts without Parts No are not supplied.

*Parts with blank version are available in common.

Ref.No	Description	Part No.	Q'ty	Version	Ref.No.	Description	Part No.	Q'ty	Version
Packaging Materials					36	Jack RCA(2P)	G601200440020	1	
	Box Carton	6017040990191	1	K	37	Jack RCA(4P)	G60240045003A	1	
	Box Carton	6017040990190	1	A,D,RDS	38	Jack RCA(6P)	G603600920030	1	
	Cushion Poly	6230042794010	1		39	Jack RCA(2P)	G601200099020	1	
	Film Soft PE	6320040052010	1		40	Jack RCA(2P)	G601200440020	1	
	Poly Bag	6330040092010	1		41	Jack RCA(4P)	G602400450050	1	
Accessories					42	Jack RCA(2P)	G601200440020	1	
	Antenna Wire (FM)	E605010010000	1		43	Jack Multi Room	G402042070000	1	A
	Antenna AM Loop Stand Strip Wire	E601010000000	1		44	Snap rivet	1560040036010	3	
	Ass'y Commander	8300040640020		K	45	Bushing Terminal	2410040270010	10	D,RDS
	Ass'y Commander	8300040640010	1	A	46	Jumper Plug	L063040750000	2	
	Ass'y Commander	8300040520040	1	D,RDS	47	Chassis Back	3207053396030	1	K
	Battery 1.5 V AA(R6M)	G670001R50010	2	D,RDS	(47)	Chassis Back	3207053396010	1	A
	Manual Instruction	5707046780010	1	K	(47)	Chassis Back	3207053396020	1	D
	Manual Instruction	5707046690010	1	A	(47)	Chassis Back	3207053396040	1	RDS
	Manual Instruction	5707046700010	1	D,RDS	48	Stopper Cord	4380040162010	1	
	Warranty Card	5727041570010	1	K	49	AC Power Cord	L061040050010	1	A
	Warranty Card	5727040060010	1	A	50	Terminal GND	3790000090000	1	
	Warranty Card	5727041620020	1	D,RDS	51	Cover Top	3000045396010	1	
Cabinet & Chassis					52	Sponge	4050043525010	1	
1	Panel Front	3067046398040	1	K	53	ANT Terminal	G590040470000	1	A,K
(1)	Panel Front	3067046248010	1	A	(53)	ANT Terminal	G59004046000A	1	D,RDS
(1)	Panel Front	3067046248030	1	D	54	Button Power	509005399101A	1	D,RDS
(1)	Panel Front	3067046248020	1	RDS	55	AC Outlet	G435040110000	1	D,RDS
2	Knob Main	5087041501010	1		(55)	AC Outlet	G435000160010	1	K
3	Knob Encoder	5087040778010	1		56	AC Power Cord	L061040210010	1	K
4	Knob Rotary	5097050641010	3		(56)	AC Power Cord	L061040090010	1	D,RDS
5	Badge, Sherwood Newcastle	5637040591010	1		(56)	AC Power Cord	L061000390060	1	RICHER
6	LED Guide	4350041551010	1		57	Rubber Sponge	4050042695010	1	
7	Decoration Cap	5127040931050	1	K	58	Bracket Heat Sink	4010057166010	5	
(7)	Decoration Cap	5127040931030	1	A	59	Shield Plate	3070046716010	1	
(7)	Decoration Cap	5127040931040	1	D,RDS	Hardware Kit				
8	Window FL	5077040063030	1	A,K	S1	Screw, #2FTC 3x8B	B010530083F10	2	
(8)	Window FL	5077040063040	1	D,RDS	S2	Screw, #B BTT 3x8B	B020030083B10	86	
9	Body Front	3417040721050	1	K	S3	Screw, #B WPTT 3x18Y	B020030181X10	3	
(9)	Body Front	3417040721030	1	A	S4	Screw, BSAM 4x8B	B020940083B10	6	
(9)	Body Front	3417040721040	1	D	S5	Screw, WSAM 4x8B	B020940083W10	4	
(9)	Body Front	3417040731020	1	RDS	S6	Screw, GUIDE 3x16Y	1507041456010	2	
10	Indicator Stanby	5160040643010	1		S7	Screw, HEAT SINK	1507041146010	10	
11	Indicator	5070044421010	4		S8	Screw, GND	1507040996010	11	
12	Button Power	5090059071010	1		S9	Screw, #B WPTT 3x6Y	B020030061W10	12	
13	Button Stanby	5090059231010	1		Miscellaneous				
14	Jack Phone(G)	G402040161330	1		SW1	Switch Power	G000041610000	1	K,D,RDS
15	Button Push	5090066821010	1		SW2	Switch Push	G000041170000	1	
16	Bracket Jack/SW	4010043616010	1		SW3	Switch Tact	G180040500010	1	A
17	Holder FL	4320040841010	2		SW4-20	Switch Tact	G180040500010	17	
18	Jack RCA	G606040300000	1		SW21-25	Switch Tact	G180040500010	5	RDS
19	Foot AL	4007041021010	2	A,K	SW26-42	Switch Tact	G180040500010	17	
(19)	Foot AL	4007040201010	2	D,RDS	VR1	VR Treble/Bass	C455121402300	2	
20	Foot PL	4000040201010	2		VR2	VR Balance	C455111402000	1	
21	Chassis Ass'y	3208056416200	1		VR3	VR Encoder	C450042030010	1	
22	Cover Power	1240044012010	1	DP,RDSP	VR4	VR Main	C49004106001A	1	
23	Knob Spacer	4300040561010	4						
24	Heat Sink Reg TR	2120043538020	2						
25	Heat Sink Reg TR	2120044358010	1						
26	Heat Sink Reg TR	2120044808010	2						
27	Bracket H/Sink	4010056906010	5						
28	Bracket H/Sink	4010056896010	1						
29	H/Sink Power	2120044988010	1						
30	Cover Fuse	1240044022010	1	DP,RDSP					
31	AC Outlet	G435040070000	1	A					
32	Terminal Speaker(8P)	G614081036000	1						
33	Terminal Speaker(2P)	G611040310000	1						
34	Jack RCA(9P)	G607901220040	1						
35	Jack RCA(9P)	G607901220050	1						

EXPLODED VIEW

Model No. : R-925R/R-925RDS

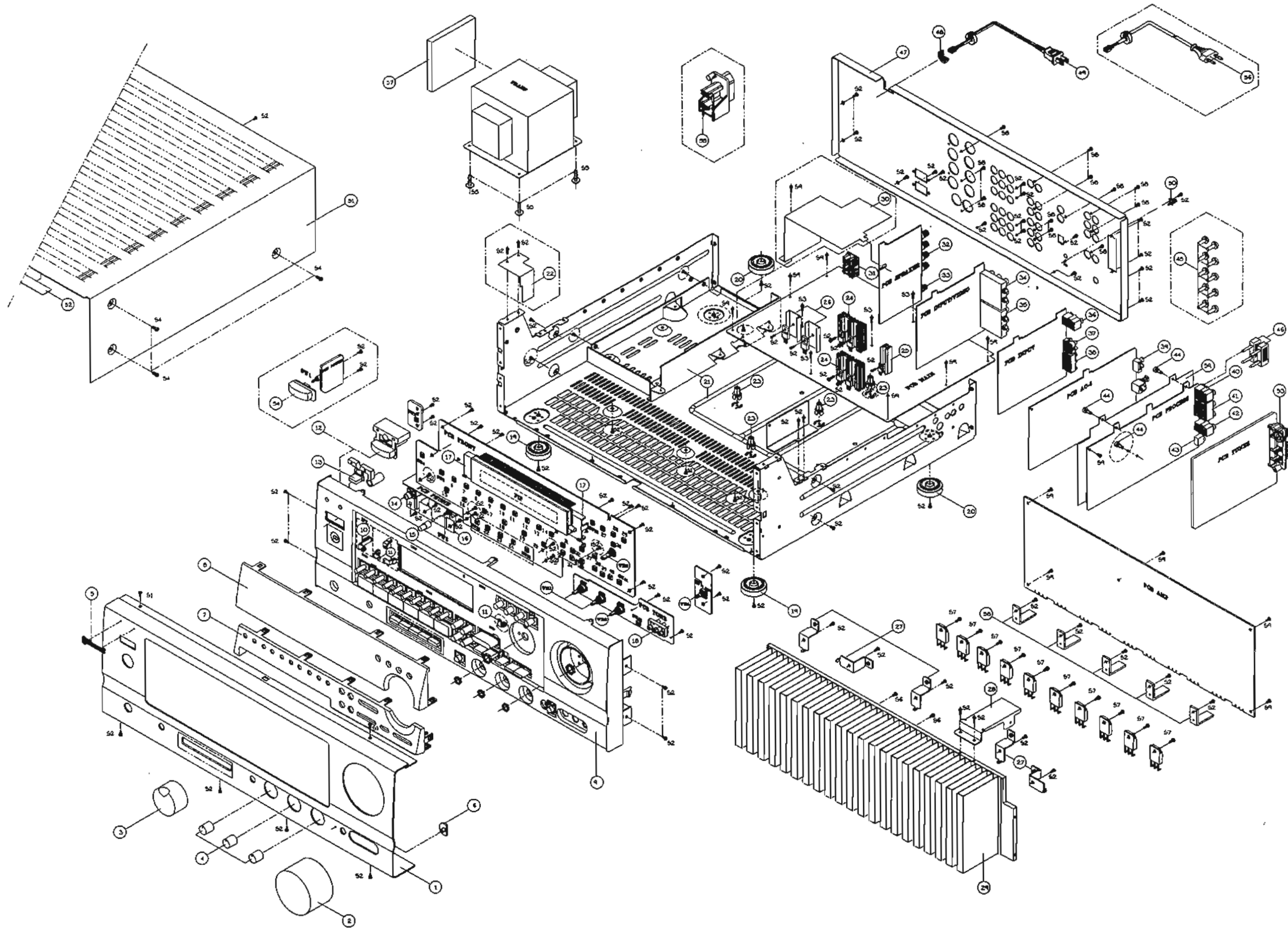

PRINTED CIRCUIT BOARDS

Model No. : R-925R/R-925RDS

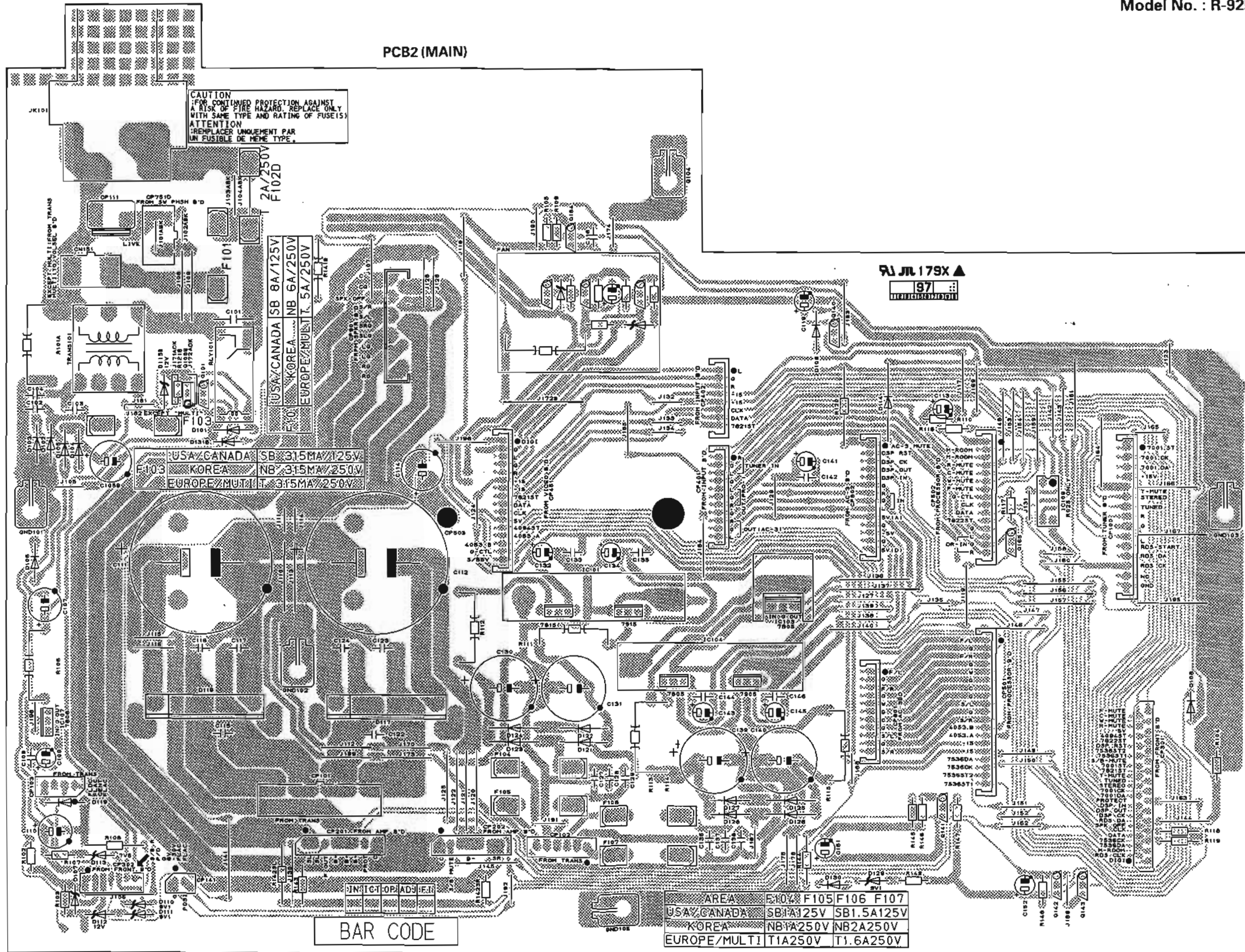

PCB3 (AMP)

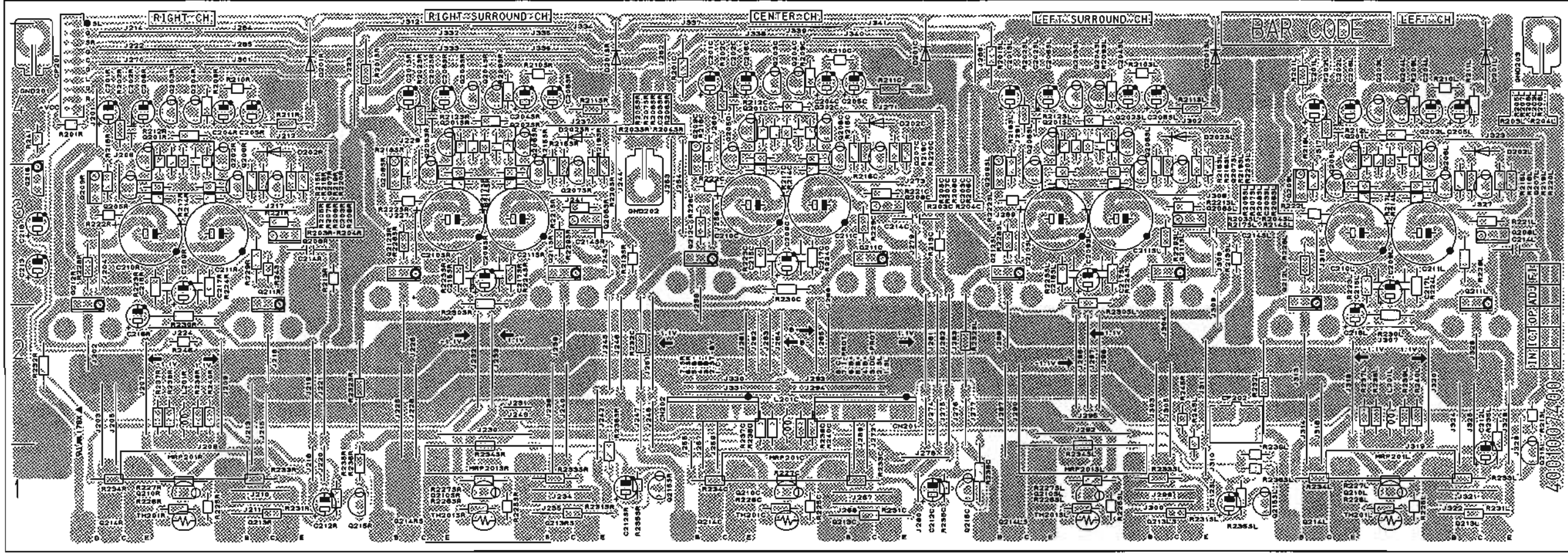

PCB6 (HP/SPK SWITCH)

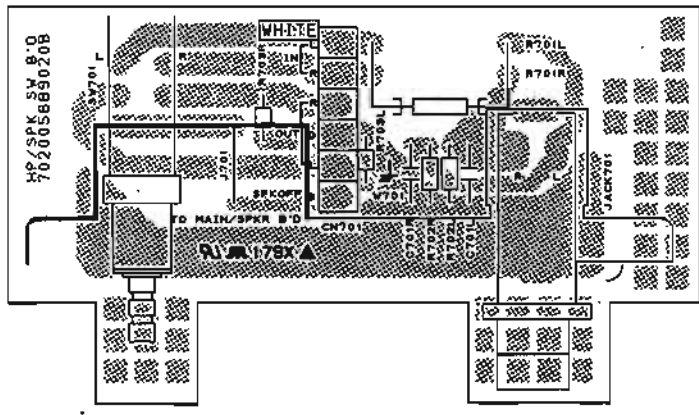

PCB8 (PUSH SWITCH)
"D" ONLY

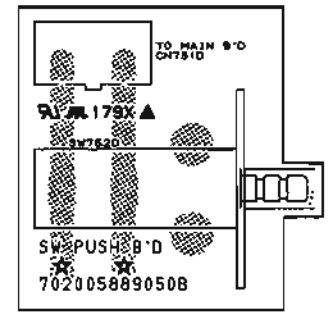

PCB5 (TONE)

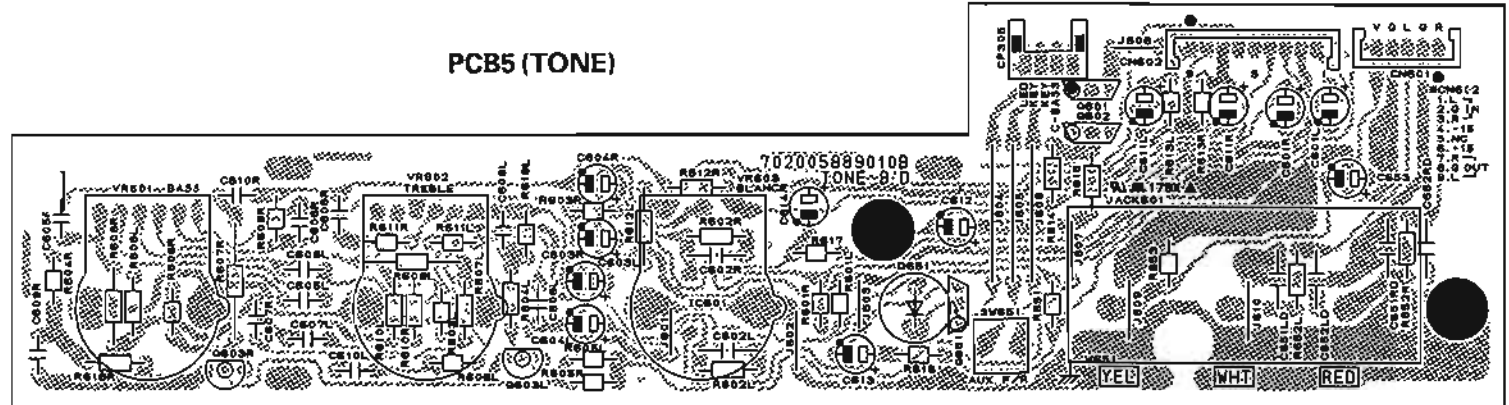

PCB4 (FRONT)

Model No. : R-925R/R-925RDS

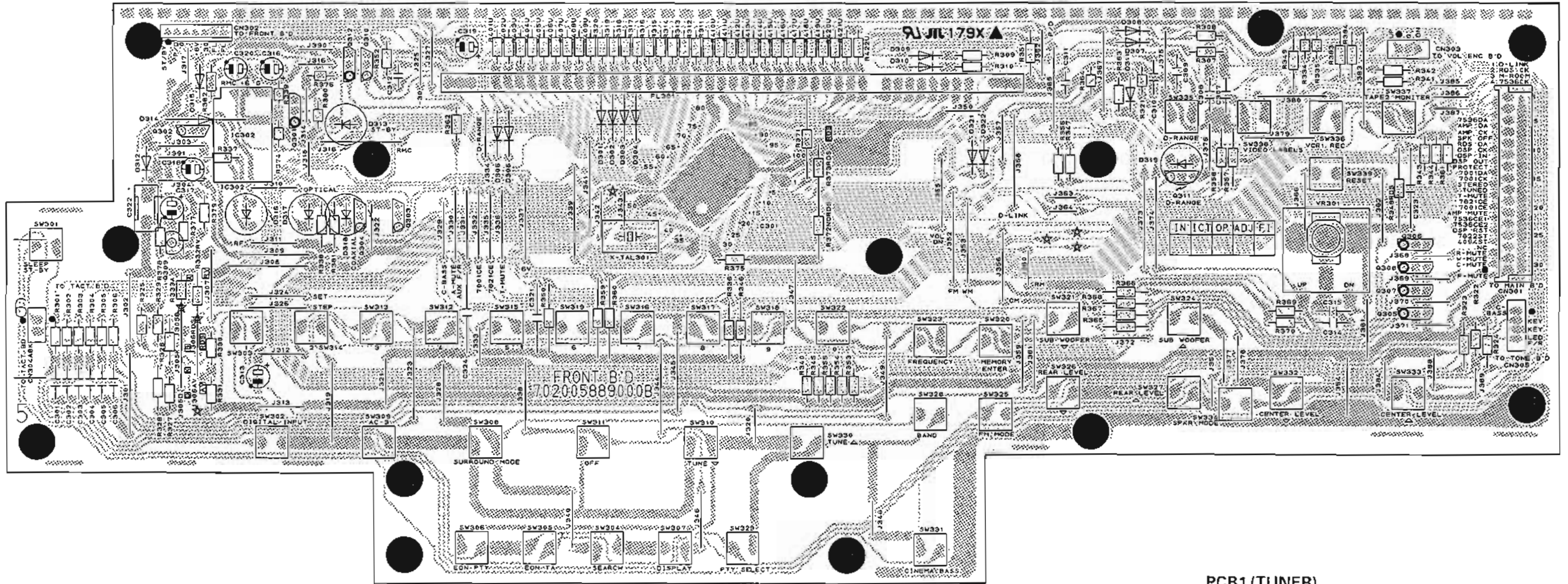

PCB1 (TUNER)

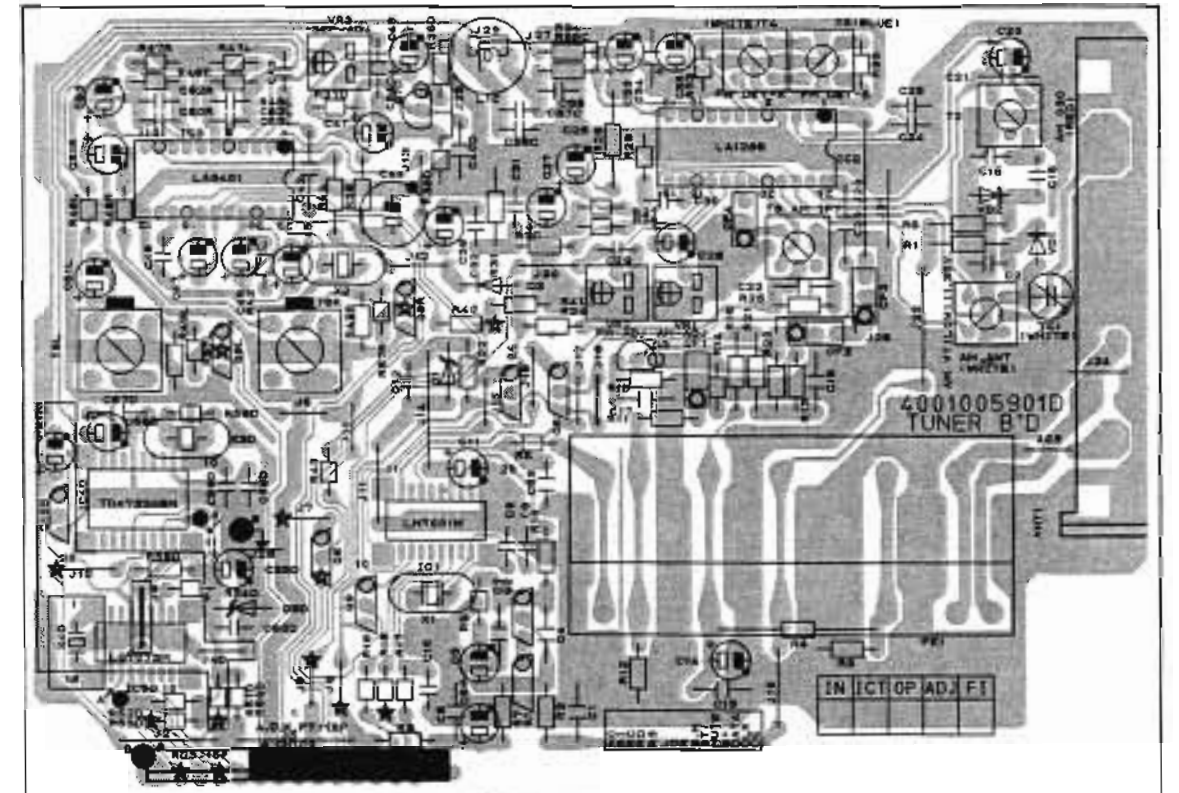

PCB12 (SPEAKER)

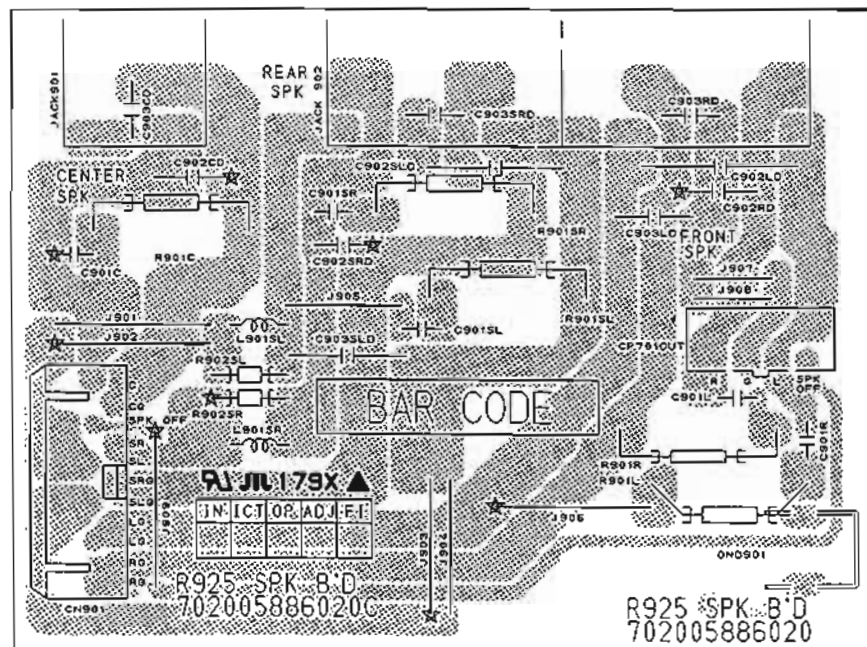

PCB7 (TACT SWITCH)

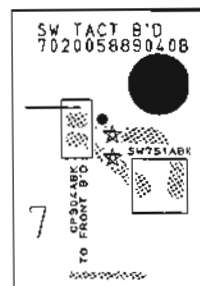

PCB9 (ENCODER)

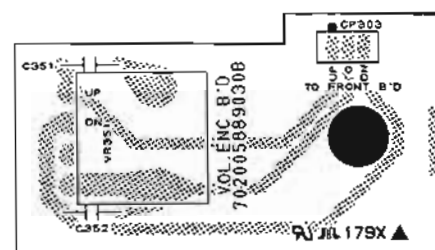

PCB13 (PROCESSOR)

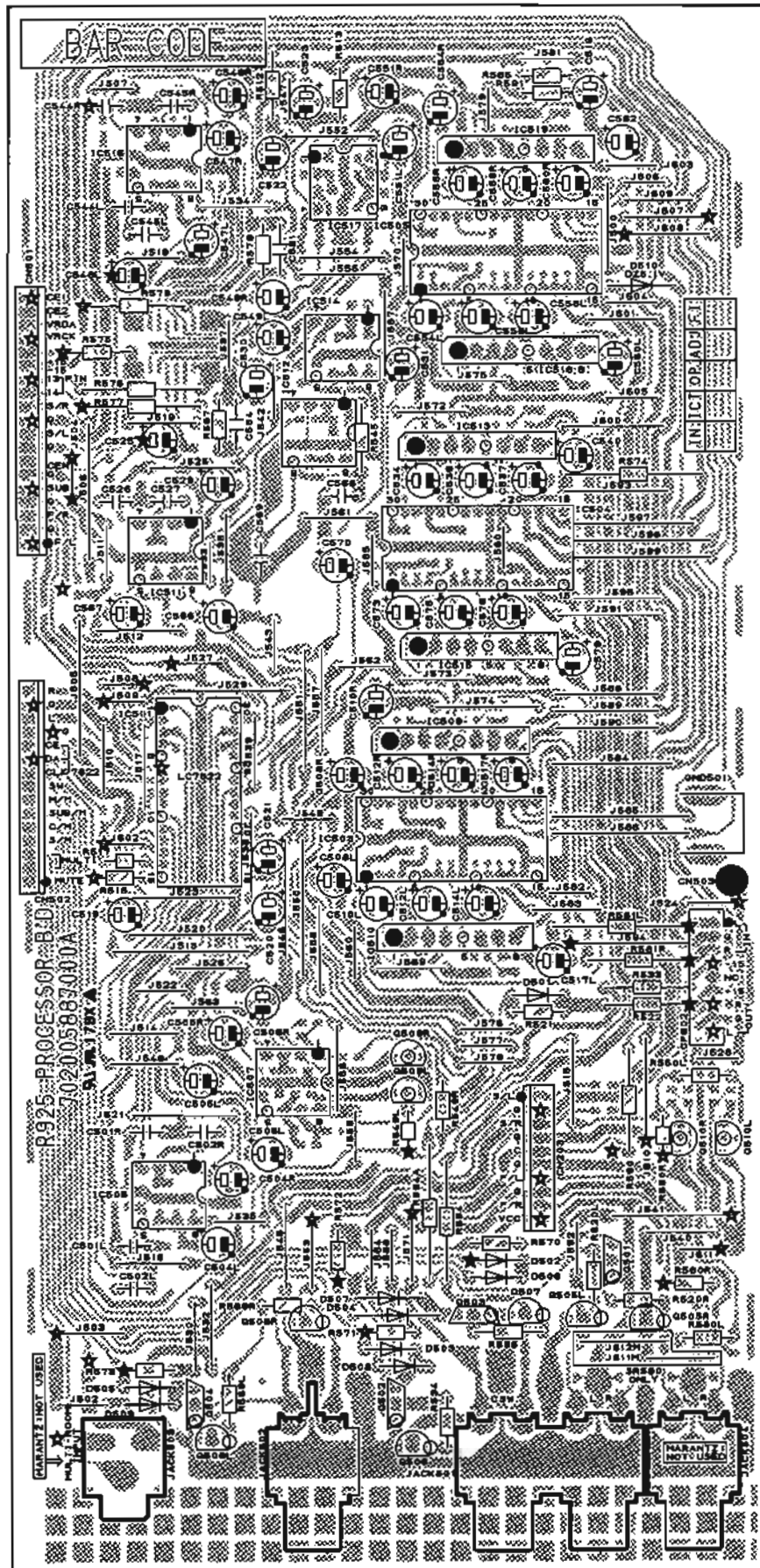

PCB10 (INPUT)

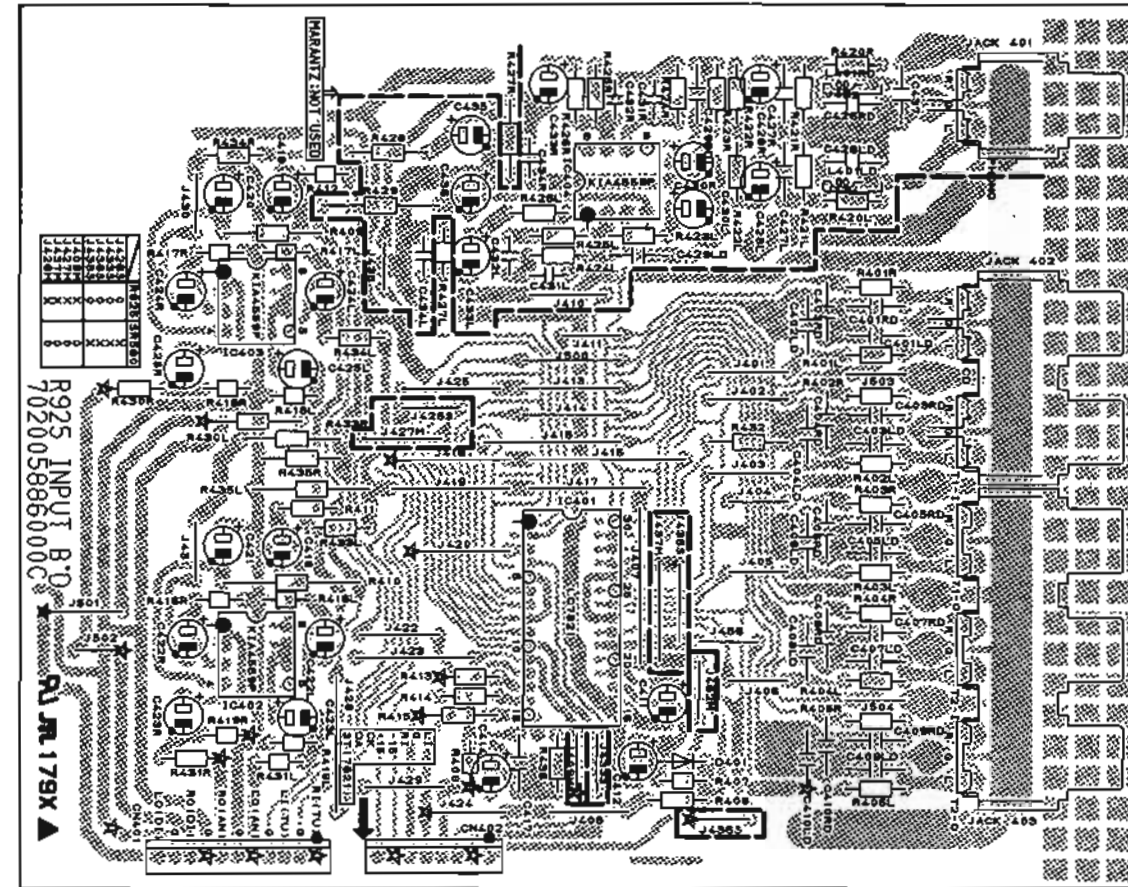

PCB15 (SUB WOOFER)

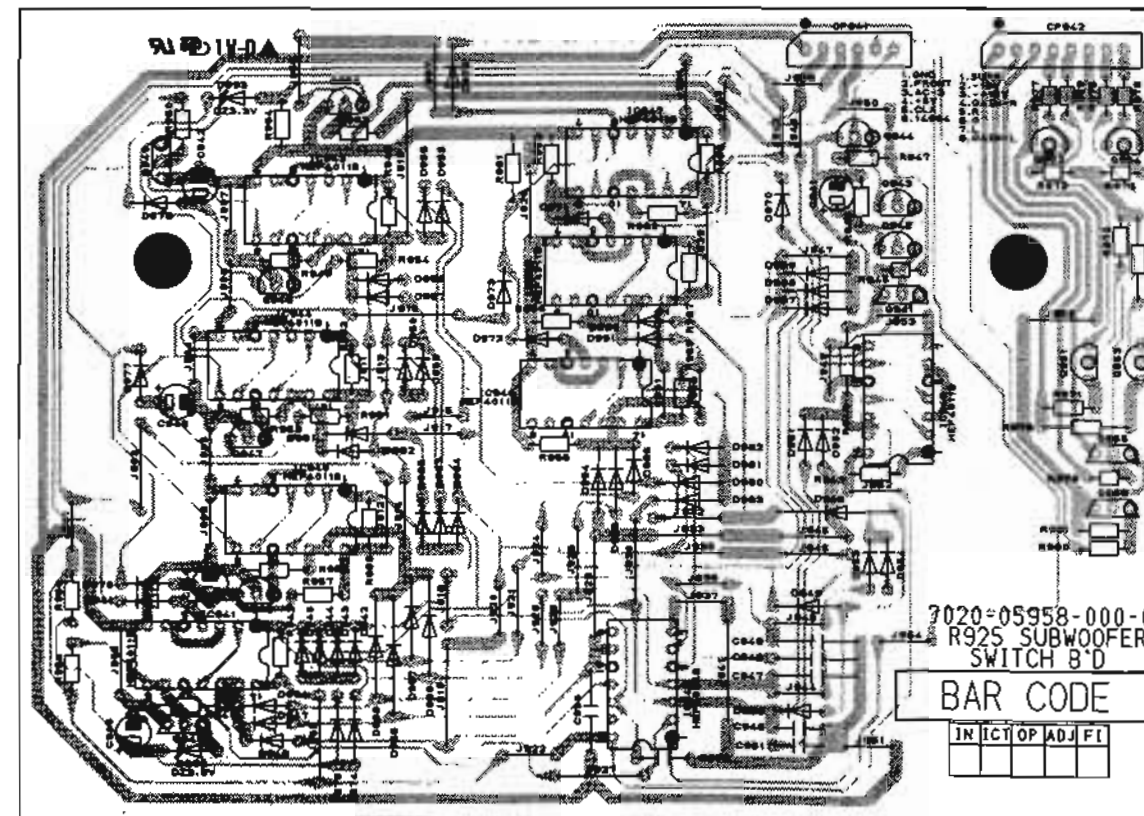

PCB14 (AC-3)

-TOP VIEW-

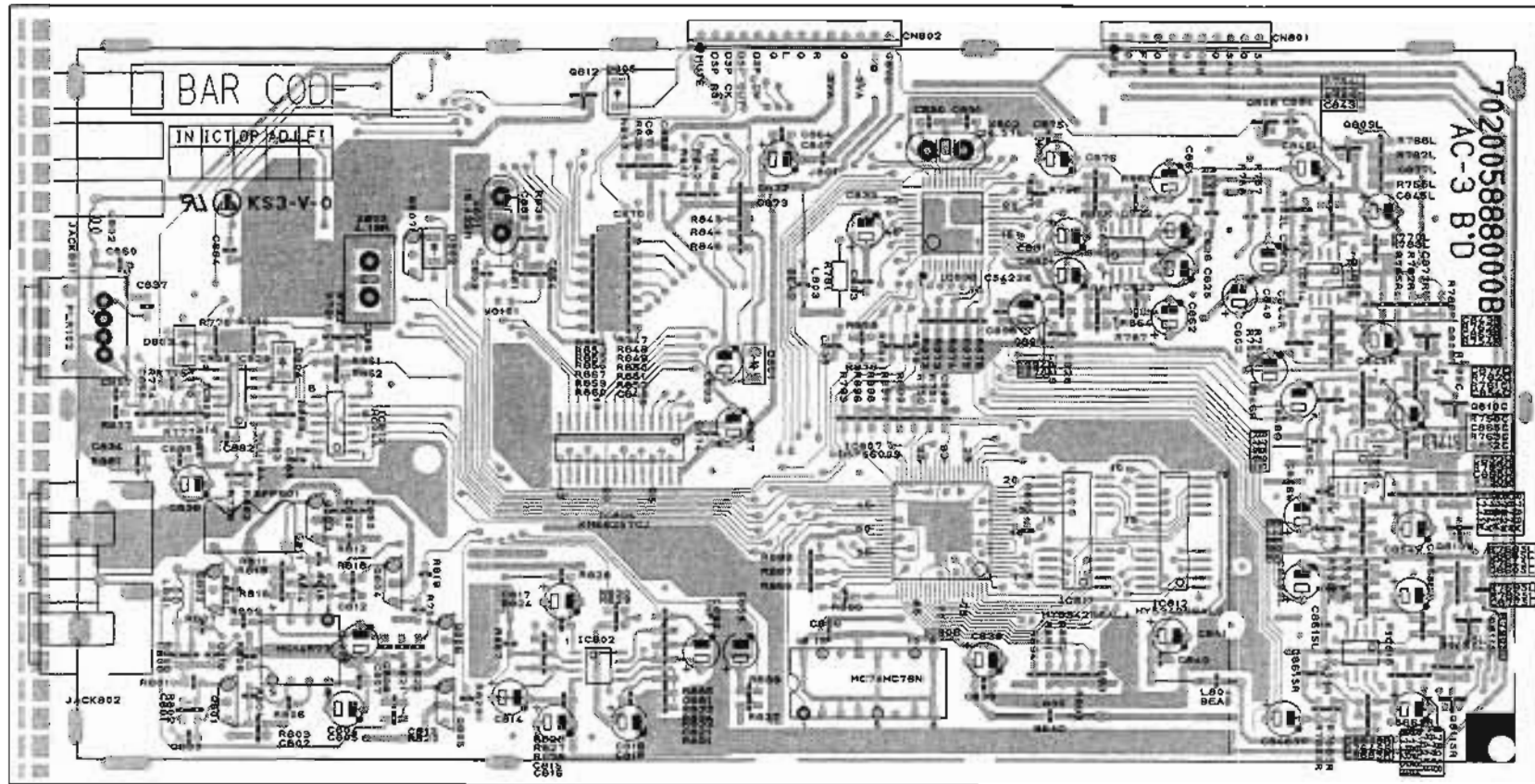

PCB14 (AC-3)

-BOTTOM VIEW-

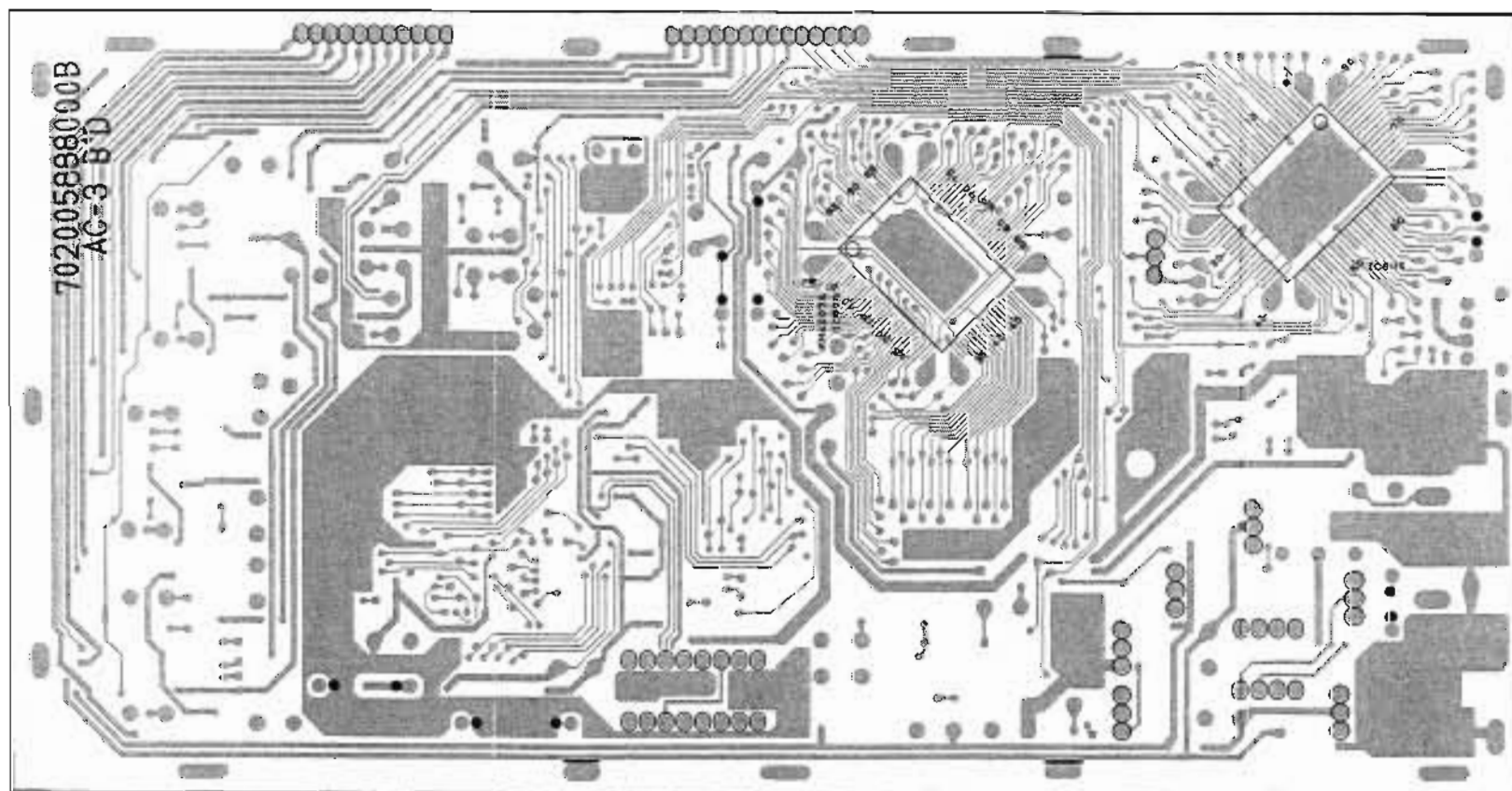

Model No. : R-925R/R-925RDS

VOL SEL (PT INDO ONLY)

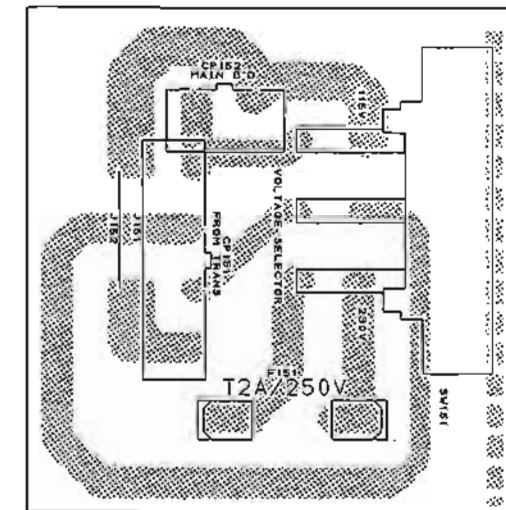

PCB11 (INPUT & VIDEO)

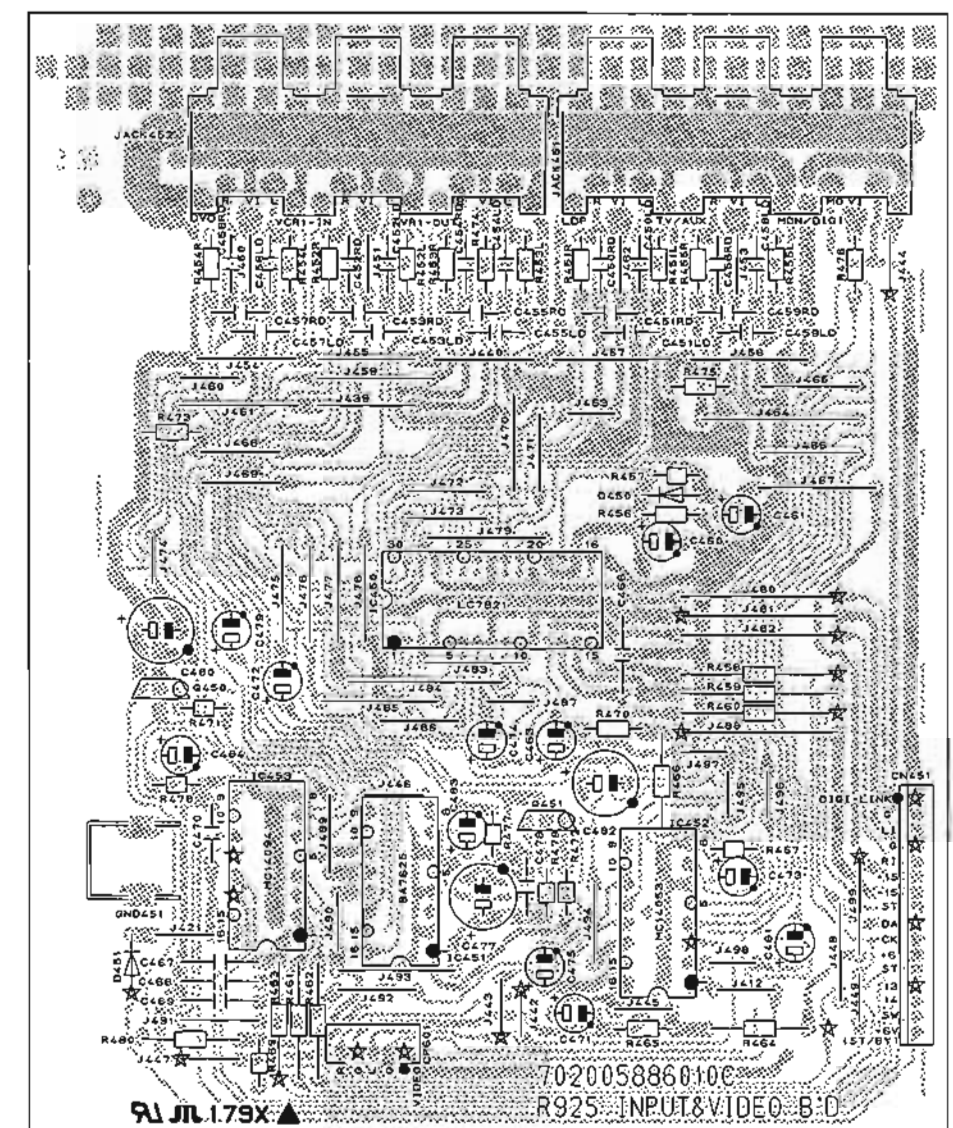

ELECTRICAL PARTS LIST

*Parts without Parts No are not supplied.
*Parts with blank version are available in common.

Ref.No.	Description	Part No.	Q'ty	Version
PCB1	ASSEMBLY P.C.BOARD TUNER	7028040887800		K
PCB1	ASSEMBLY P.C.BOARD TUNER	7028040889200		A
Capacitors				
C1	Ceramic H/K Axial	0.022 uF	25 V	D005223574530 1
C2	Ceramic H/K Disc	0.047 uF	50 V	Z D004473097060 1
C3	Elect GE	3.3 uF	50 V	M D0403R3087100 1
C4	Ceramic H/K Axial	10000 pF	16 V	D005103773530 1
C5	Elect GE	47 uF	16 V	M D040470083100 1
C6	Ceramic H/K Axial	0.022 uF	25 V	D005223574530 1
C7	Ceramic H/K Axial	10000 pF	16 V	D005103773530 1
C8/9	Ceramic Disc	18 pF	50 V	J D000180167070 2
C10	Ceramic H/K Disc	100 pF	50 V	J D004101067060 1
C11	Elect GE	47 uF	16 V	M D040470083100 1
C12	Ceramic H/K Disc	0.022 uF	50 V	Z D004223097060 1
C13	Ceramic H/K Axial	0.022 uF	25 V	D005223574530 1
C14	Elect GE	100 uF	16 V	M D040101083100 1
C15	Film Stylor	470 pF	50 V	J D022471067050 1
C16	Ceramic Disc	15 pF	50 V	J D000150167070 1
C17/18	Ceramic H/K Axial	0.022 uF	25 V	D005223574530 2
C20	Elect GE	10 uF	35 V	M D040100085100 1
C21/22	Ceramic H/K Axial	0.022 uF	25 V	D005223574530 2
C23	Ceramic H/K Axial	10000 pF	16 V	D005103773530 1
C24/25	Ceramic H/K Disc	0.022 uF	50 V	Z D004223097060 2
C26	Elect GE	4.7 uF	50 V	M D0404R7087100 1
C27	Elect GE	3.3 uF	50 V	M D0403R3087100 1
C28	Elect GE	4.7 uF	50 V	M D0404R7087100 1
C29	Ceramic H/K Disc	0.022 uF	50 V	Z D004223097060 1
C30	Film Polyester	0.022 uF	100V	J D02022306C060 1
C31	Film Polyester	0.0033 uF	100V	J D02033206C060 1
C32	Film Polyester	0.039 uF	100V	J D02039306C060 1
C33	Elect GE	1 uF	50 V	M D040010087100 1
C34	Ceramic H/K Axial	0.022 uF	25 V	D005223574530 1
C35	Elect GE	100 uF	16 V	M D040101083100 1
C36	Ceramic H/K Disc	330 pF	50 V	J D004331067060 1
C39	Elect GE	10 uF	35 V	M D040100085100 1
C41	Elect GE	4.7 uF	50 V	M D0404R7087100 1
C42	Ceramic H/K Axial	0.047 uF	50 V	D005473097530 1
C43	Ceramic H/K Disc	680 pF	50 V	J D004681067060 1
C44	Elect GE	100 uF	16 V	M D040101083100 1
C45	Elect GE	1 uF	50 V	M D040010087100 1
C46	Elect GE	0.22 uF	50 V	M D040R22087100 1
C47	Elect GE	1 uF	50 V	M D040010087100 1
C48	Ceramic H/K Disc	0.022 uF	50 V	Z D004223097060 1
C49	Elect GE	10 uF	35 V	M D040100085100 1
C50/LR	Ceramic H/K Disc	560 pF	50 V	J D004581067060 2
C51/LR	Elect GE	10 uF	35 V	M D040100085100 2
C53	Elect GE	10 uF	35 V	M D040100085100 1
C62/LR	Ceramic Disc	68 pF	50 V	J D000680067060 2
Ceramic Filters				
CF1	SFE10.7MA8-A-TF21			E430107000140 1
CF3	SFE10.7MA8-A-TF21			E430107000140 1
CF4	CFM2-450BL			E431450000120 1
Diodes				
D1	UZ 5.1 BSB, Zener			K06005R114520 1
D2	1N4148M, Switching			K000414801520 1
VD1/VD2	SVC321SPA-C			K080032100520 2
Integrated Circuits				
IC1	LM7001M			J124700100010 1
IC2	LA1268G			J124126600010 1
IC3	LA3401			J124340100010 1
Transistors				
Q1/Q2	2SC1740S, NPN			J5021740S0010 2
Q3	KTC1923Y/KTC3194Y, NPN			J5023194Y0050 1
Q4-Q6	KRA107M/DTA114YS, PNP			J601107M00050 3
Q8/LR	DTC323TS, NPN			J602323TS0050 2
Q9	KRA107M/DTA114YS, PNP			J601107M00050 1
Resistors				
R1	Carbon Film	100 kohm	1/5 W	J C00001046P520 1
R2	Carbon Film	5.6 kohm	1/5 W	J C00005626P520 1
R3	Carbon Film	22 kohm	1/5 W	J C00002236P520 1
R4	Carbon Film	100 kohm	1/5 W	J C00001046P520 1

Ref.No.	Description	Part No.	Q'ty	Version
R5	Metal Film	470 ohm	1/5 W	J C06004716P520 1
R6	Carbon Film	100 kohm	1/5 W	J C00001046P520 1
R7	Carbon Film	10 kohm	1/5 W	J C00001036P520 1
R8	Metal Film	270 ohm	1/5 W	J C06002716P520 1
R9	Metal Film	560 ohm	1/5 W	J C06005616P520 1
R10	Metal Film	1 kohm	1/5 W	J C06001026P520 1
R11	Metal Film	180 ohm	1/5 W	J C06001816P520 1
R12	Metal Film	560 ohm	1/5 W	J C06005616P520 1
R13	Metal Film	3.3 kohm	1/5 W	J C06003326P520 1
R14	Metal Film	560 ohm	1/5 W	J C06005616P520 1
R15	Metal Film	470 ohm	1/5 W	J C06004716P520 1
R16	Metal Film	100 ohm	1/5 W	J C06001016P520 1
R17-19	Metal Film	1 kohm	1/5 W	J C06001026P520 3
R20	Metal Film	330 ohm	1/5 W	J C06003316P520 1
R21	Metal Film	270 ohm	1/5 W	J C06002716P520 1
R22	Metal Film	470 ohm	1/5 W	J C06004716P520 1
R24	Metal Film	4.7 kohm	1/5 W	J C06004736P520 1
R25	Carbon Film	58 kohm	1/5 W	J C00006836P520 1
R26	Carbon Film	18 kohm	1/5 W	J C00001836P520 1
R27	Carbon Film	10 kohm	1/5 W	J C00001036P520 1
R28	Carbon Film	22 kohm	1/5 W	J C00002236P520 1
R29	Metal Film	22 ohm	1/5 W	J C06002206P520 1
R30	Metal Film	4.7 kohm	1/5 W	J C06004736P520 1
R31	Carbon Film	10 kohm	1/5 W	J C00001036P520 1
R32	Carbon Film	5.6 kohm	1/5 W	J C00005626P520 1
R33	Metal Film	3.3 kohm	1/5 W	J C06003326P520 1
R34	Metal Film	100 ohm	1/5 W	J C06001016P520 1
R39	Metal Film	100 ohm	1/5 W	J C06001016P520 1
R40	Carbon Film	47 kohm	1/5 W	J C00004736P520 1
R41	Carbon Film	22 kohm	1/5 W	J C00002236P520 1
R42	Metal Film	3.3 kohm	1/5 W	J C06003326P520 1
R43	Carbon Film	22 kohm	1/5 W	J C00002236P520 1
R44	Carbon Film	47 kohm	1/5 W	J C00004736P520 1
R46/LR	Carbon Film	120 kohm	1/5 W	J C00001246P520 2
R47/LR	Carbon Film	180 kohm	1/5 W	J C00001846P520 2
R48/LR	Metal Film	2.7 kohm	1/5 W	J C06002726P520 2
R49/LR	Metal Film	3.3 kohm	1/5 W	J C06003326P520 2
R57/LR	Metal Film	1.5 kohm	1/5 W	J C06001526P520 2
Coils				
T1	AM-Antenna			D304564300000 1
T2	AM-OSC			D940111027000 1
T3	AM-IFT P-7SB			D950010050000 1
T4	FM-DET-A			D970010040000 1
T5	FM-DET-B			D970010060000 1
T6/LR	MPX(19/38kHz) BLK			E401500100000 2
Semi Fixed Variable Resistors				
VR1	5K(B)-H			C541502115000 1
VR2	50K(B)-H			C541503115000 1
VR3	200K(B)-H			C541204115000 1
Miscellaneous				
CN100	PLUG 10P, 35238-1010			L12252419100A 1
FE1	Tuner FM, FTA4-556HB			E900455600100 1
TC1	Trimmer Ceramic, 10 pF			D110100901100 1
X1	7.2 MHz			E800720000080 1
X2	Resonator, CSB456F			E830456000050 1
PCB1	ASSEMBLY P.C.BOARD TUNER	7028040890600		D
PCB1	ASSEMBLY P.C.BOARD TUNER	7028040892000		RD\$
Capacitors				
C1	Ceramic H/K Axial	0.022 uF	25 V	D005223574530 1
C2	Ceramic H/K Disc	0.047 uF	50 V	Z D004473097060 1
C3	Elect GE	3.3 uF	50 V	M D0403R3087100 1
C4	Ceramic H/K Axial	10000 pF	16 V	D005103773530 1
C5	Elect GE	47 uF	16 V	M D040470083100 1
C6	Ceramic H/K Axial	0.022 uF	25 V	D005223574530 1
C7	Ceramic H/K Axial	10000 pF	16 V	D005103773530 1
C8/9	Ceramic Disc	18 pF	50 V	J D000180167070 2
C10	Ceramic H/K Disc	100 pF	50 V	J D004101067060 1
C11	Elect GE	47 uF	16 V	M D040470083100 1
C12	Ceramic H/K Disc	0.022 uF	50 V	Z D004223097060 1
C13	Ceramic H/K Axial	0.022 uF	25 V	D005223574530 1
C14	Elect GE	100 uF	16 V	M D040101083100 1
C15	Film Stylor	470 pF	50 V	J D022471067050 1
C16	Ceramic Disc	15 pF	50 V	J D000150167070 1
C17/18	Ceramic H/K Axial	0.022 uF	25 V	D005223574530 2

Ref.No.	Description	Part No.	Q'ty	Version
C20	Elect GE	10 uF	35 V	M D040100085100 1
C21/22	Ceramic H/K Axial	0.022 uF	25 V	D005223574530 2
C23	Ceramic H/K Axial	10000 pF	16 V	D005103773530 1
C24/25	Ceramic H/K Disc	0.022 uF	50 V	Z D004223097060 2
C26	Elect GE	4.7 uF	50 V	M D0404R7087100 1
C27	Elect GE	3.3 uF	50 V	M D0403R3087100 1
C28	Elect GE	4.7 uF	50 V	M D0404R7087100 1
C29	Ceramic H/K Disc	0.022 uF	50 V	Z D004223097060 1
C30	Film Polyester	0.022 uF	100V	J D02022306C060 1
C31	Film Polyester	0.0033 uF	100V	J D02033206C060 1
C32	Film Polyester	0.039 uF	100V	J D02039306C060 1
C33	Elect GE	1 uF	50 V	M D040010087100 1
C34	Ceramic H/K Axial	0.022 uF	25 V	D005223574530 1
C35	Elect GE	100 uF	16 V	M D040101083100 1
C36	Ceramic H/K Disc	330 pF	50 V	J D004331067060 1
C37C	Ceramic Disc	82 pF	50 V	J D000820067060 1
C38C	Ceramic H/K Disc	100 pF	50 V	J D004101067060 1
C39	Elect GE	10 uF	35 V	M D040100085100 1
C40D	Ceramic H/K Axial	0.022 uF	25 V	D005223574530 1
C41	Elect GE	4.7 uF	50 V	M D0404R7087100 1
C42	Ceramic H/K Axial	0.047 uF	50 V	D005473097530 1
C43	Ceramic H/K Disc	680 pF	50 V	J D004681067060 1
C44	Elect GE	100 uF	16 V	M D040101083100 1
C45	Elect GE	1 uF	50 V	M D040010087100 1
C46	Elect GE	0.22 uF	50 V	M D040R22087100 1
C47	Elect GE	1 uF	50 V	M D040010087100 1
C48	Ceramic H/K Disc	0.022 uF	50 V	Z D004223097060 1
C49	Elect GE	10 uF	35 V	M D040100085100 1
C50L	Ceramic H/K Disc	220 pF	50 V	J D004221067060 1
C50R	Ceramic H/K Disc	220 pF	50 V	J D004221067060 1
C51/LR	Elect GE	10 uF	35 V	M D040100085100 2
C53	Elect GE	10 uF	35 V	M D040100085100 1
C54D	Ceramic H/K Axial	270 pF	50 V	D005271077530 1
C55D	Elect GE	47 uF	16 V	M D040470083100 1
C56D	Elect GE	10 uF	35 V	M D040100085100 1
C57D	Ceramic H/K Axial	0.1 uF	50 V	D005104097530 1
C58D/59D	Ceramic H/K Disc	27 pF	50 V	J D004270067060 2
C60D	Ceramic H/K Disc	0.1 uF	50 V	Z D004104097060 1
C62/LR	Ceramic Disc	10 pF	50 V	J D000100067060 2
Ceramic Filters				
CF1	10M7S3GH			E430107000150 1
CF3	10M7S3GH			E430107000150 1
CF4	CFM2-450BL			E431450000120 1
Diodes				
D1	UZ 5.1 BSB, Zener			K06005R114520 1
D2	1N4148M, Switching			K000414801520 1
D3D	UZ 5.1 BSB, Zener			K08005R114520 1
VD1/2	SVC321SPA-C			K080032100520 2
Integrated Circuits				
IC1</				

Ref.No.	Description	Part No.	Q'ty	Version
R4	Carbon Film	100 kohm 1/5 W J C00001046P520	1	
R5	Metal Film	470 ohm 1/5 W J C06004716P520	1	
R6	Carbon Film	100 kohm 1/5 W J C00001046P520	1	
R7	Carbon Film	10 kohm 1/5 W J C00001036P520	1	
R8	Metal Film	270 ohm 1/5 W J C06002716P520	1	
R9	Metal Film	560 ohm 1/5 W J C06005616P520	1	
R10	Metal Film	1 kohm 1/5 W J C06001026P520	1	
R11	Metal Film	180 ohm 1/5 W J C06001816P520	1	
R12	Metal Film	560 ohm 1/5 W J C06005616P520	1	
R13	Metal Film	3.3 kohm 1/5 W J C06003326P520	1	
R14	Metal Film	560 ohm 1/5 W J C06005616P520	1	
R15	Metal Film	470 ohm 1/5 W J C06004716P520	1	
R16	Metal Film	100 ohm 1/5 W J C06001016P520	1	
R17/18	Metal Film	1 kohm 1/5 W J C06001026P520	2	
R20	Metal Film	330 ohm 1/5 W J C06003316P520	1	
R21	Metal Film	270 ohm 1/5 W J C06002716P520	1	
R22	Metal Film	470 ohm 1/5 W J C06004716P520	1	
R24	Metal Film	4.7 kohm 1/5 W J C06004726P520	1	
R25	Carbon Film	68 kohm 1/5 W J C00006836P520	1	
R26	Carbon Film	47 kohm 1/5 W J C00004736P520	1	
R27	Carbon Film	10 kohm 1/5 W J C00001036P520	1	
R28	Carbon Film	22 kohm 1/5 W J C00002236P520	1	
R29	Metal Film	22 ohm 1/5 W J C06002206P520	1	
R30	Metal Film	4.7 kohm 1/5 W J C06004726P520	1	
R31	Metal Film	2.7 kohm 1/5 W J C06002726P520	1	
R32	Carbon Film	5.6 kohm 1/5 W J C00005626P520	1	
R33	Metal Film	3.3 kohm 1/5 W J C06003326P520	1	
R34	Metal Film	100 ohm 1/5 W J C06001016P520	1	
R35C	Metal Film	1.8 kohm 1/5 W J C06001826P520	1	
R36D	Carbon Film	47 kohm 1/5 W J C00004736P520	1	
R37D	Metal Film	22 ohm 1/5 W J C06002206P520	1	
R38D	Metal Film	1 kohm 1/5 W J C06001026P520	1	
R39	Metal Film	100 ohm 1/5 W J C06001016P520	1	
R40	Carbon Film	47 kohm 1/5 W J C00004736P520	1	
R41	Carbon Film	22 kohm 1/5 W J C00002236P520	1	
R42	Metal Film	3.3 kohm 1/5 W J C06003326P520	1	
R43	Carbon Film	22 kohm 1/5 W J C00002236P520	1	
R44	Carbon Film	47 kohm 1/5 W J C00004736P520	1	
R46L/R	Carbon Film	220 kohm 1/5 W J C00002246P520	2	
R47L/R	Carbon Film	270 kohm 1/5 W J C00002746P520	2	
R48L/R	Metal Film	2.7 kohm 1/5 W J C06002726P520	2	
R49L/R	Metal Film	3.3 kohm 1/5 W J C06003326P520	2	
R50D	Metal Film	880 ohm 1/5 W J C06008816P520	1	
R52D/53D	Carbon Film	10 kohm 1/5 W J C00001036P520	2	
R56D	Carbon Film	2.2 Mohm 1/5 W J C00002256P520	1	
R57L/R	Metal Film	1.5 kohm 1/5 W J C06001526P520	2	
Semi Fixed Variable Resistors				
VR1	5K(B)-H	C541502115000	1	
VR2	50K(B)-H	C541503115000	1	
VR3	200K(B)-H	C541204115000	1	
Miscellaneous				
CN100	PLUG, 15P M.O	L112524191800	1	
FE1	Tuner FM, FTH4-460H	E900446000110	1	
TC1	Trimmer Ceramic, 10 pF	D110100901100	1	
X1	7.2 MHz	E800720000080	1	
X2	Resonator, CSB456F	E830456000050	1	
X3D	4.332 MHz	E800433200060	1	
PCB2 ASSEMBLY P.C.BOARD MAIN 7028040887000 K				
PCB2 ASSEMBLY P.C.BOARD MAIN 7028040888400 A				
PCB2 ASSEMBLY P.C.BOARD MAIN 7028040889900 D				
PCB2 ASSEMBLY P.C.BOARD MAIN 7028040891200 RDS				
Capacitors				
C101	Ceramic AC (Safety)	0.0047 uF 400 VA D00847208K03D	1	
C102~104	Film Polyester	0.047 uF 100 V J D02047308C060	3	
C107	Elect GE	330 uF 25 V M D040331084100	1	
C108	Ceramic H/K Disc	0.1 uF 50 V Z D004104097060	1	
C109	Elect GE	1 uF 50 V M D040010087100	1	
C110	Elect GE	100 uF 35 V M D040101085100	1	
C111~112	Elect GE	15000 uF 63 V M D040153088300	2	
C113	Elect GE	1 uF 50 V M D040010087100	1	
C114	Elect GE	1000 uF 10 V M D040102082200	1	
C115~118	Film Polyester	0.1 uF 250 V K D02010407H080	4	
C119	Elect GE	1 uF 50 V M D040010087100	1	
C122~124	Film Polyester	0.1 uF 250 V K D02010407H080	3	
C127/128	Film Polyester	0.047 uF 100 V J D02047308C060	2	

Ref.No.	Description	Part No.	Q'ty	Version
C130/131	Elect GE	2200 uF 35 V M D040222085200	2	
C132	Elect GE	1 uF 50 V M D040010087100	1	
C133	Ceramic H/K Disc	0.1 uF 50 V Z D004104097060	1	
C134	Elect GE	1 uF 50 V M D040010087100	1	
C135	Ceramic H/K Disc	0.1 uF 50 V Z D004104097060	1	
C136~138	Film Polyester	0.047 uF 100 V J D02047308C060	3	
C139	Elect GE	10000 uF 16 V M D040103083020	1	
C140	Elect GE	2200 uF 16 V M D040222083020	1	
C141	Elect GE	1 uF 50 V M D040010087100	1	
C142	Ceramic H/K Disc	0.1 uF 50 V Z D004104097060	1	
C143	Elect GE	1 uF 50 V M D040010087100	1	
C144	Ceramic H/K Disc	0.1 uF 50 V Z D004104097060	1	
C145	Elect GE	1 uF 50 V M D040010087100	1	
C146	Ceramic H/K Disc	0.1 uF 50 V Z D004104097060	1	
C151	Elect GE	1 uF 50 V M D040010087100	1	
C152	Elect GE	470 uF 6.3 V M D040471081100	1	
Connectors				
CN151	Wafer, 7.92mm, 2P	L104353280200	1	
CP100	B'D to B'D Plug, 2.5mm, 15P	L102532911910	1	
CP101	Wafer, 7.92mm, 4P	L104353280400	1	
CP102	Wafer, 2.5mm, 8P	L102526706010	1	
CP103	Wafer, 2.5mm, 4P	L102526704010	1	
CP111	Wafer, 7.92mm, 2P	L10882P300010	1	
CP114	Wafer, 2.5mm, 2P	L102526702010	1	
CP201	Wafer, 2.5mm, 8P	L102526708010	1	
CP202	Wafer, 2.5mm, 7P	L102526707010	1	
CP301	FPC Plug, 1.25mm, 31P	L131520453100	1	
CP302	Wafer, 2.0mm, 7P	L101220070000	1	
CP401	B'D to B'D Plug, 2.0mm, 11P	L101353361110	1	
CP402	B'D to B'D Plug, 2.0mm, 8P	L101353360810	1	
CP451	B'D to B'D Plug, 2.0mm, 16P	L101353361610	1	
CP501	B'D to B'D Plug, 2.0mm, 19P	L101353361910	1	
CP502	B'D to B'D Plug, 2.0mm, 15P	L101353361510	1	
CP503	CNT Assy, 300mm, 1P	L033595840300	1	
CP751D	Wafer, 7.92mm, 2P	L104353280200	1	D,RDS
	CNT Assy, 2P	L011025047770	1	D,RDS
CP801	B'D to B'D Plug, 2.0mm, 11P	L101353361110	1	
CP901	B'D to B'D Plug, 2.5mm, 11P	L102534211110	1	
Diodes				
D101~106	1N4003, Rectifier	K040400300520	6	
D107	UZ4.3BSB, Zener	K06004R314520	1	
D108/109	1N4148M, Switching	K000414801520	2	
D110/111	UZ9.1BSC, Zener	K06009R124520	2	
D112	UZ12BSC, Zener	K060120024520	1	
D113	UZ7.5BSC, Zener	K06007R524520	1	
D114	1N4148M, Switching	K000414801520	1	
D116/117	D5SBA60, Rectifier Bridge	K047056000010	2	
D119~128	1N4003, Rectifier	K040400300520	10	
D129	UZ9.1BSC, Zener	K06009R124520	1	
D130	1N4148M, Switching	K000414801520	1	
Fuses				
F101	Fuse, SB 8A, 125V	G650802121150	1	A
	Fuse, T 5A, 250V	G650502251160	1	D,RDS
	Fuse, NB 6A, 250V	G650602251150	1	K
F102D	Fuse, T 2AL, 250V	G650202251160	1	D,RDS
F103	Fuse, SB 315mA, 125V	G650311121160	1	A
	Fuse, T 315mA, 250V	G650311251160	1	D,RDS
	Fuse, NB 315mA, 250V	G650311251150	1	K
F104/105	Fuse, SB 1A, 125V	G650102121160	2	A
	Fuse, T 1AL, 250V	G650102251160	2	D,RDS
	Fuse, NB 1A, 250V	G650102251150	2	K
F106/107	Fuse, SB 1.5A, 125V	G650152121150	2	A
	Fuse, T 1.6AL, 250V	G650162251160	2	D,RDS
	Fuse, NB 2A, 250V	G650202251150	2	K
Integrated Circuits				
IC101	KIA7815, Linear-Regulator	J126781500020	1	
IC102	KIA7915, Linear-Regulator	J126791500030	1	
IC103/104	KIA7805, Linear-Regulator	J126780500270	2	
IC105	KIA7905, Linear-Regulator	J126790500070	1	
IC106	LTV817, Optocoupler	K614817000001	1	
IC107	KIA7806, Linear-Regulator	J126780600120	1	
Transistors				
Q101	DTC114YS, NPN	J8020114Y0050	1	

Ref.No.	Description	Part No.	Q'ty	Version
Q140	DTA114YS, NPN	J801114YS0050	1	
Q141	BKTA1287, PNP	J5001267Y0050	1	
Q142/143	2SC1740S, NPN	J5021740S0010	2	
Q184	BKTC3199, NPN	J5023199Y0050	1	
Q165	DTC114YS, NPN	J8020114Y0050	1	
Resistors				
R101	Metal Film	3.3 Mohm 1/2 W J C060033574530	1	
R102	Metal Film	470 ohm 1/5 W J C06004716P520	1	
R103	Carbon Film	10 kohm 1/5 W J C00001036P520	1	
R104	Carbon Film	1 Mohm 1/5 W J C00001056P520	1	
R105	Carbon Film	100 kohm 1/5 W J C00001046P520	1	
R106	Metal Film	10 ohm 2 W J C060010068520	1	
R107	Carbon Film	15 kohm 1/5 W J C00001536P520	1	
R108	Metal Film	330 ohm 1/5 W J C06003316P520	1	
R109	Carbon Film	1 Mohm 1/5 W J C00001056P520	1	
R110	Carbon Film	100 kohm 1/5 W J C00001046P520	1	
R111/112	Metal Film	10 ohm 2 W J C060010066520	2	
R113~115	Metal Film	1 ohm 2 W J C060001066520	3	
R116	Metal Film	470 ohm 1/5 W J C06004716P520	1	
R117	Metal Film	1 kohm 1/5 W J C06001026P520	1	
R118/119	Metal Film	470 ohm 1/5 W J C06004716P520	2	
R120	Metal Film	4.7 kohm 1/5 W J C06004726P520	1	
R142SL/SR	Carbon Film	22 kohm 1/5 W J C00002236P520	2	
R143	Carbon Film	22 kohm 1/5 W J C00002236P520	1	
R144	Metal Film	4.7 kohm 1/5 W J C06004726P520	1	
R145	Carbon Film	100 kohm 1/5 W J C00001046P520	1	
R146	Carbon Film	68 kohm 1/5 W J C00006836P520	1	
R147	Metal Film	3.3 kohm 1/5 W J C06003326P520	1	
R148	Metal Film	1.5 kohm 1/5 W J C06001526P520	1	
R149	Metal Film	1 kohm 1/5 W J C06001026P520	1	
Miscellaneous				
RLY101	SDT-SS-112DM/12VDC - 5A, Relay	G680125020010	1	
TRANS101	Standby Trans, 120V/60Hz	8200280960010	1	A
	Standby Trans, 230V/50Hz	8200281012910	1	D,RDS
	Standby Trans, 220V/60Hz	8200280909010	1	K
POWER TRAN	Power Transformer, 120V/60Hz	8200281016260	1	A
	Power Transformer, 230V/50Hz	8200281016360	1	D,RDS
	Power Transformer, 220V/60Hz	8200281016460	1	K
POSISTOR	Posistor Assy, 180 2.5P	F328380001830	1	
PCB3 ASSEMBLY P.C.BOARD AMP 7028040887200 K				
PCB3 ASSEMBLY P.C.BOARD AMP 7028040888600 A				
PCB3 ASSEMBLY P.C.BOARD AMP 7028040890000 D				
PCB3 ASSEMBLY P.C.BOARD AMP 7028040891400 RDS				
Capacitors				
C201L/R/C	Elect GE	47 uF 16 V M D040470083100	3	
C201SL/SR	Elect GE	47 uF 16 V M D040470083100	2	
C202L/R/C	Ceramic T.C Axial	100 pF 50 V J D001101077530	3	
C202SL/SR	Ceramic H/K Axial	270 pF 50 V J D005271077530	2	
C203L/R/C	Not Used!			
C203SL/SR	Not Used!			
C204L/R/C	Elect GE	1 uF 50 V M D040010087100	3	
C204SL/SR	Elect GE	1 uF 50 V M D040010087100	2	
C205L/R/C	Elect GE	22 uF 16 V M D040220083100	3	
C205SL/SR	Elect GE	22 uF 16 V M D040220083100	2	
C206L/R/C	Elect GE	220 uF 10 V M D040221082100	3	
C206SL/SR	Elect GE	220 uF 10 V M D040221082100	2	
C209L/R/C	Elect GE	10 uF 50 V M D040100087100	3	
C209SL/SR	Elect GE	10 uF 50 V M D040100087100	2	
C210L/R/C	Elect GE	470 uF 63 V M D040471088020	3	
C210SL/SR	Elect GE	470 uF 63 V M D040471088020	2	
C211L/R/C	Elect GE	470 uF 63 V M D040471088020	3	
C211SL/SR	Elect GE	470 uF 63 V M D040471088020	2	
C212L/R/C	Elect GE	10 uF 50 V M D040100087100	3	
C212SL/SR	Elect GE	10 uF 50 V M D040100087100	2	
C214L/R/C	Ceramic T.C Axial	1 pF 50 V J D001010077530	3	
C214SL/SR	Ceramic T.C Axial	1 pF 50 V J D001010077530	2	
C215L/R/C	Ceramic H/K Axial	180 pF 50 V J D005181077530	3	
C215SL/SR	Ceramic H/K Axial	180 pF 50 V J D005181077530	2	
C216L/R	Elect GE	10 uF 50 V M D040100087100	2	
C218	Elect GE			

Ref.No.	Description	Part No.	Q'ty	Version
CP201	Wafer 2.0mm, 10P	L104353130200	1	
CP202	Wafer 3.96mm, 2P	L101220100000	1	
Diodes				
D201L/R/C	1N4148M, Switching	K000414801520	3	
D201SL/SR	1N4148M, Switching	K000414801520	2	
D202L/R/C	1N4148M, Switching	K000414801520	3	
D202SL/SR	1N4148M, Switching	K000414801520	2	
Transistors				
Q201L/R/C	KTA1268, PNP	J5001268B0050	3	
Q201SL/SR	KTA1268, PNP	J5001268B0050	2	
Q202L/R/C	KTA1268, PNP	J5001268B0050	3	
Q202SL/SR	KTA1268, PNP	J5001268B0050	2	
Q203L/R/C	KTA1268, PNP	J5001268B0050	3	
Q203SL/SR	KTA1268, PNP	J5001268B0050	2	
Q204L/R/C	KTA1268, PNP	J5001268B0050	3	
Q204SL/SR	KTA1268, PNP	J5001268B0050	2	
Q205L/R/C	BKTC3200, NPN	J5023200B0050	3	
Q205SL/SR	BKTC3200, NPN	J5023200B0050	2	
Q206L/R/C	BKTC3200, NPN	J5023200B0050	3	
Q206SL/SR	BKTC3200, NPN	J5023200B0050	2	
Q207L/R/C	KTA1268, PNP	J5001268B0050	3	
Q207SL/SR	KTA1268, PNP	J5001268B0050	2	
Q208L/R/C	2SA1360, PNP	J5001360O000D	3	
Q208SL/SR	2SA1360, PNP	J5001360O000D	2	
Q209L/R/C	2SC3423, NPN	J5023423O0000	3	
Q209SL/SR	2SC3423, NPN	J5023423O0000	2	
Q210L/R/C	2SC1740S, NPN	J5021740S0010	3	
Q210SL/SR	2SC1740S, NPN	J5021740S0010	2	
Q211L/R/C	2SC4883, NPN	J5024883Y0000	3	
Q211SL/SR	2SC4883, NPN	J5024883Y0000	2	
Q212L/R/C	2SA1859, PNP	J5001859Y0000	3	
Q212SL/SR	2SA1859, PNP	J5001859Y0000	2	
Q213L/R/C	2SC5200, NPN	J502520000010	3	
Q213SL/SR	2SC5200, NPN	J502520000010	2	
Q214L/R/C	2SA1943, PNP	J500194300010	3	
Q214SL/SR	2SA1943, PNP	J500194300010	2	
Q215L/R/C	BKTC3200, NPN	J5023200B0050	3	
Q215SL/SR	BKTC3200, NPN	J5023200B0050	2	
Resistors				
MRP201L/R/C	Cement MPR Dual	0.27 ohm 5 W J C144R27069300	3	
MRP201SL/SR	Cement MPR Dual	0.27 ohm 5 W J C144R27069300	2	
R201L/R/C	Metal Film	1 kohm 1/5 W J C06001026P520	3	
R201SL/SR	Metal Film	1 kohm 1/5 W J C06001026P520	2	
R202L/R/C	Carbon Film	33 kohm 1/5 W J C00003336P520	3	
R202SL/SR	Carbon Film	33 kohm 1/5 W J C00003336P520	2	
R203L/R/C	Metal Film	180 ohm 1/5 W J C06001816P520	3	
R203SL/SR	Metal Film	180 ohm 1/5 W J C06001816P520	2	
R204L/R/C	Metal Film	180 ohm 1/5 W J C06001816P520	3	
R204SL/SR	Metal Film	180 ohm 1/5 W J C06001816P520	2	
R205L/R/C	Metal Film	1.5 kohm 1/5 W J C06001526P520	3	
R205SL/SR	Metal Film	1.5 kohm 1/5 W J C06001526P520	2	
R206L/R/C	Metal Film	1.5 kohm 1/5 W J C06001526P520	3	
R206SL/SR	Metal Film	1.5 kohm 1/5 W J C06001526P520	2	
R207L/R/C	Not Used!			
R207SL/SR	Not Used!			
R208L/R/C	Carbon Film	18 kohm 1/5 W J C00001836P520	3	
R208SL/SR	Carbon Film	18 kohm 1/5 W J C00001836P520	2	
R209L/R/C	Metal Film	220 ohm 1/5 W J C06002216P520	3	
R209SL/SR	Metal Film	220 ohm 1/5 W J C06002216P520	2	
R210L/R/C	Carbon Film	10 kohm 1/5 W J C00001036P520	3	
R210SL/SR	Carbon Film	10 kohm 1/5 W J C00001036P520	2	
R211L/R/C	Carbon Film	43 kohm 1/5 W J C00004336P520	3	
R211SL/SR	Carbon Film	43 kohm 1/5 W J C00004336P520	2	
R212L/R/C	Carbon Film	1.3 kohm 1/5 W J C00001326P520	3	
R212SL/SR	Carbon Film	1.3 kohm 1/5 W J C00001326P520	2	
R213L/R/C	Carbon Film	33 kohm 1/5 W J C00003336P520	3	
R213SL/SR	Carbon Film	33 kohm 1/5 W J C00003336P520	2	
R214L/R/C	Metal Film	560 ohm 1/5 W J C06005616P520	3	
R214SL/SR	Metal Film	560 ohm 1/5 W J C06005616P520	2	
R215L/R/C	Jumper	L045084006020	3	
R215SL/SR	Jumper	L045084006020	2	
R216L/R/C	Metal Film	560 ohm 1/5 W J C06005616P520	3	
R216SL/SR	Metal Film	560 ohm 1/5 W J C06005616P520	2	
R217L/R/C	Metal Film	560 ohm 1/5 W J C06005616P520	3	
R217SL/SR	Metal Film	560 ohm 1/5 W J C06005616P520	2	
R218L/R/C	Metal Film	4.7 kohm 1/5 W J C06004726P520	3	

Ref.No.	Description	Part No.	Q'ty	Version
R218SL/SR	Metal Film	4.7 kohm 1/5 W J C06004726P520	2	
R219L/R/C	Metal Film	560 ohm 1/5 W J C06005616P520	3	
R219SL/SR	Metal Film	560 ohm 1/5 W J C06005616P520	2	
R220L/R/C	Metal Film	4.7 kohm 1/5 W J C06004726P520	3	
R220SL/SR	Metal Film	4.7 kohm 1/5 W J C06004726P520	2	
R221L/R/C	Metal Film	82 ohm 1/5 W J C06008206P520	3	
R221SL/SR	Metal Film	82 ohm 1/5 W J C06008206P520	2	
R222L/R/C	Metal Film	82 ohm 1/5 W J C06008206P520	3	
R222SL/SR	Metal Film	82 ohm 1/5 W J C06008206P520	2	
R223L/R/C	Carbon Film	22 kohm 1/5 W J C00002236P520	3	
R223SL/SR	Carbon Film	22 kohm 1/5 W J C00002236P520	2	
R224L/R/C	Carbon Film	22 kohm 1/5 W J C00002236P520	3	
R224SL/SR	Carbon Film	22 kohm 1/5 W J C00002236P520	2	
R225L/R/C	Carbon Film	2 kohm 1/5 W J C00002026P520	3	
R225SL/SR	Carbon Film	2 kohm 1/5 W J C00002026P520	2	
R226L/R/C	Metal Film	680 ohm 1/5 W J C06006816P520	3	
R226SL/SR	Metal Film	680 ohm 1/5 W J C06006816P520	2	
R227L/R/C	Metal Film	1.2 kohm 1/5 W J C06001226P520	3	
R227SL/SR	Metal Film	1.2 kohm 1/5 W J C06001226P520	2	
R228L/R/C	Metal Film	75 ohm 1/5 W J C06007506P520	3	
R228SL/SR/C	Metal Film	220 ohm 1/5 W J C06002216P520	3	
R229L/R/C	Metal Film	75 ohm 1/5 W J C06007506P520	2	
R229SL/SR/C	Metal Film	220 ohm 1/5 W J C06002216P520	3	
R230L/R/C	Metal Film	82 ohm 1/5 W J C06008206P520	3	
R230SL/SR	Metal Film	82 ohm 1/5 W J C06008206P520	2	
R231L/R/C	Metal Film	3.3 ohm 1/5 W J C0603R306P520	3	
R231SL/SR	Metal Film	3.3 ohm 1/5 W J C0603R306P520	2	
R232L/R/C	Metal Film	3.3 ohm 1/5 W J C0603R306P520	3	
R232SL/SR	Metal Film	3.3 ohm 1/5 W J C0603R306P520	2	
R233L/R/C	Metal Film	1.8 kohm 1/5 W J C06001826P520	3	
R233SL/SR	Metal Film	1.8 kohm 1/5 W J C06001826P520	2	
R234L/R/C	Carbon Film	2 kohm 1/5 W J C00002026P520	3	
R234SL/SR	Carbon Film	2 kohm 1/5 W J C00002026P520	2	
R235L/R/C	Metal Film	910 ohm 1/5 W J C06009116P520	3	
R235SL/SR	Metal Film	910 ohm 1/5 W J C06009116P520	2	
R236L/R/C	Carbon Film	6.8 kohm 1/5 W J C00006826P520	3	
R236SL/SR	Carbon Film	6.8 kohm 1/5 W J C00006826P520	2	
R237L/R/C	Metal Film	39 ohm 1/5 W J C06003906P520	3	
R237SL/SR	Metal Film	39 ohm 1/5 W J C06003906P520	2	
R238L/R/C	Metal Film	39 ohm 1/5 W J C06003906P520	3	
R238SL/SR	Metal Film	39 ohm 1/5 W J C06003906P520	2	
R240L/R/C	Metal Film	560 ohm 1/5 W J C06005616P520	1	
R243	Metal Film	560 ohm 1/5 W J C06005616P520	2	
R245L/R	Carbon Film	22 kohm 1/5 W J C00002236P520	1	
R246	Metal Film	560 ohm 1/5 W J C06005616P520	1	
Miscellaneous				
GND201	Terminal GND		3790040876010	1
L201L/R/C	Filter Inductor, 0.5 uH		D330900001320	3
TH201L/R/C	Thermistor, 3 kohm		F340530200000	3
TH201SL/SR	Thermistor, 3 kohm		F340530200000	2
* ASSEMBLY P.C.BOARD FRONT (PCB 4, 5, 6, 7, 8, 9) 7028040887400 K				
* ASSEMBLY P.C.BOARD FRONT (PCB 4, 5, 6, 7, 8, 9) 7028040888800 A				
* ASSEMBLY P.C.BOARD FRONT (PCB 4, 5, 6, 7, 8, 9) 7028040890200 D				
* ASSEMBLY P.C.BOARD FRONT (PCB 4, 5, 6, 7, 8, 9) 7028040891600 RDS				
PCB4 ASSEMBLY P.C.BOARD FRONT				
Capacitors				
C301-310	Ceramic T.C Axial	100 pF 50 V J D001101077530	10	
C312	Film Polyester	0.047 uF 100 V J D02047306C060	1	
C313	Elect GE	0.1 uF 50 V M D040R10087100	1	
C314/315	Ceramic T.C Axial	820 pF 50 V J D001821077530	2	
C316	Elect GE	47 uF 16 V M D040470083100	1	
C317	Elect GE	47 uF 25 V M D040470084100	1	
C318	Elect GE	10 uF 50 V M D040100087100	1	
C319	Elect GE	47 uF 50 V M D040470087100	1	
C320	Elect GE	10 uF 16 V M D040100083100	1	
C321	Ceramic T.C Axial	100 pF 50 V J D001101077530	1	
C322	Double Layer	0.047 uF 5.5 V D090473700200	1	
C323/324	Ceramic T.C Axial	100 pF 50 V J D001101077530	2	
Connectors				
CN301	FPC Plug Angle, 1.25mm, 31P		L131520443100	1
	FPC Cable, 1.25mm, 31P		L302331310010	1
CN302	CNT Ass'y, 400mm, 7P		L022074031320	1
CN303	CNT Ass'y, 160mm, 3P		L024031632320	1
CP304ABK	CNT Ass'y, 2P		L024020832310	1 A,B,K
CN305	CNT Ass'y, 80mm, 4P		L021040833320	1

Ref.No.	Description	Part No.	Q'ty	Version
Diodes				
D301-312	1N4148M, Switching	K000414801520	12	
D313	SLR-34URCF25, Round	K500032101120	1	
D314/315	1N4148M, Switching	K000414801520	2	
D316-319	SLR-34URCF25, Round	K500032101120	4	
D321/322	1N4148M, Switching	K000414801520	2	
Transistors				
Q301	BKTC3199, NPN	J5023199Y0050	1	
Q302-304	DTC114YS, NPN	J6020114Y0050	3	
Q305-308	BKTC3199, NPN	J5023199Y0050	4	
Q309	MPSA06, NPN	J5020600Y0050	1	
Q310/311	DTC114YS, NPN	J6020114Y0050	2	
Q312	BKTC3199, NPN	J5023199Y0050	1	
Resistors				
R301-310	Metal Film	1 kohm 1/5 W J C06001026P520	10	
R311-320	Carbon Film	100 kohm 1/5 W J C00001048P520	10	
R321-324	Carbon Film	47 kohm 1/5 W J C00004736P520	4	
R325	Carbon Film	22 kohm 1/5 W J C00002236P520	1	
R326-328	Carbon Film	10 kohm 1/5 W J C00001036P520	3	
R329	Metal Film	4.7 kohm 1/5 W J C06004726P520	1	
R330/331	Carbon Film	22 kohm 1/5 W J C00002236P520	2	
R332RV	Carbon Film	10 kohm 1/5 W J C00001036P520	1 A	
R333A	Carbon Film	10 kohm 1/5 W J C00001036P520	1 A	
R334/335	Carbon Film	68 kohm 1/5 W J C00006836P520	2	
R336	Carbon Film	10 kohm 1/5 W J C00001036P520	1	
R337/338	Metal Film	470 ohm 1/5 W J C06004716P520	2	
R339	Metal Film	3.9 kohm 1/5 W J C06003926P520	1	
R340	Carbon Film	10 kohm 1/5 W J C00001036P520	1	
R341/342	Metal Film	1 kohm 1/5 W J C06001026P520	2	
R343/344	Carbon Film	22 kohm 1/5 W J C00002236P520	2	
R345/346	Carbon Film	10 kohm 1/5 W J C00001036P520	2	
R347	Metal Film	100 ohm 1/5 W J C06001016P520	1	
R348RDS	Carbon Film	100 kohm 1/5 W J C00001046P520	1 RDS	
R349	Metal Film	470 ohm 1/5 W J C06004716P520	1	
R350	Carbon Film	100 kohm 1/5 W J C00001046P520	1	
R351/352	Metal Film	3.3 kohm 1/5 W J C06003396P520	2	
R353/354	Carbon Film	5.6 kohm 1/5 W J C00005626P520	2	
R355	Carbon Film	10 kohm 1/5 W J C00001036P520	1	
R356	Metal Film	100 ohm 1/5 W J		

Ref.No.	Description	Part No.	Q'ty	Version
C606L/R	Film Polyester	0.015 uF	63 V	J D020153068050 2
C607L/R	Film Polyester	0.022 uF	63 V	J D020223068050 2
C608L/R	Film Polyester	0.0033 uF	63 V	J D020332068050 2
C609L/R	Film Polyester	0.33 uF	63 V	J D020334068050 2
C610L/R	Film Polyester	0.0082 uF	63 V	J D020822068050 2
C611L/R	Elect GE	10 uF	16 V	M D040100083120 2
C612	Elect GE	3.3 uF	50 V	M D0403R3087100 1
C613/C614	Elect GE	47 uF	25 V	M D040470084100 2
C651LD/RD	Ceramic T.C Axial	100 pF	50 V	J D001101077530 2 D,RDS
C652LD/RD	Ceramic T.C Axial	100 pF	50 V	J D001101077530 2 D,RDS
C653	Elect GE	33 uF	25 V	M D040330084100 1
Connectors				
CP305	Wafer, 2.0mm, 4P, ANGEL	L101220040010	1	
CN601	Wafer, 2.0mm, 5P CNT Assy, 5P	L101220050000 L021054584320	1	
CN602	Wafer, 2.0mm, 9P CNT Assy, 9P	L101220090000 L021094070320	1	
W651	Lug Wire, 1P	L046241020580	1	
Diodes				
D651	SLR-58URCF14, Round	K500052101160	1	
Transistors				
Q601	DTC114YS, NPN	J6020114Y0050	1	
Q802	DTA114YS, PNP	J801114YS0050	1	
Q603L/R	2SK117Y	J5441170Y0050	2	
Q651	DTC114YS, NPN	J6020114Y0050	1	
Resistors				
R601L/R	Carbon Film	100 kohm	1/5 W	J C00001046P520 2
R602L/R	Carbon Film	1 Mohm	1/5 W	J C00001056P520 2
R603L/R	Carbon Film	47 kohm	1/5 W	J C00004736P520 2
R604L/R	Metal Film	2.7 kohm	1/5 W	J C06002726P520 2
R605L/R	Carbon Film	10 Mohm	1/5 W	J C00001066P520 2
R606L/R	Metal Film	4.7 kohm	1/5 W	J C06004726P520 2
R607L/R	Carbon Film	27 kohm	1/5 W	J C00002736P520 2
R608L/R	Metal Film	3.3 kohm	1/5 W	J C06003328P520 2
R609L/R	Carbon Film	22 kohm	1/5 W	J C00002236P520 2
R610L/R	Metal Film	560 ohm	1/5 W	J C06005616P520 2
R611L/R	Metal Film	2.2 kohm	1/5 W	J C06002226P520 2
R612L/R	Metal Film	1.8 kohm	1/5 W	J C06001826P520 2
R613L/R	Carbon Film	100 kohm	1/5 W	J C00001046P520 2
R614	Carbon Film	100 kohm	1/5 W	J C00001046P520 1
R615	Carbon Film	1 Mohm	1/5 W	J C00001056P520 1
R616/617	Metal Film	220 ohm	1/5 W	J C06002216P520 2
R618L/R	Carbon Film	1 Mohm	1/5 W	J C00001056P520 2
R651	Metal Film	620 ohm	1/5 W	J C06008216P520 1
R652L/R	Metal Film	470 ohm	1/5 W	J C06004716P520 2
R653	Metal Film	75 ohm	1/5 W	J C06007506P520 1
Miscellaneous				
CP601	Wafer, 2.0mm, 5P	L101220050000	1	
IC601	NJM2068M, Linear OP	J121208800020	1	
SW651	Tact Sw	G180040500010	1	D
VR601/602	RK16K128000114C, RMD41	C455121402300	2	
VR603	RK16K118000114H, RMM44	C455111402000	1	
JACK601	RCA, 3P	G606040300000	1	
PCB5 ASSEMBLY P.C. BOARD HP/SPK SWITCH				
C701L/R	Ceramic H/K Axial	560 pF	50 V	J D005561077530 2
CN701	CNT Assy 6P(2P+4P)	L018065042660	1	
JACK701	HTJ064-11D(G)	G402040161330	1	
R701L/R	Metal Film	470 ohm	2 W	J C060047166520 2
R702L/R	Carbon Film	15 kohm	1/5 W	J C00001536P520 2
R703L/R	Carbon Film	22 kohm	1/5 W	J C00002236P520 2
SW701	SPLL, 19 x 1M071 SU690	G000040960000	1	
W701	Lug, 1P	L046241020580	1	
PCB7 ASSEMBLY P.C. BOARD TACT SWITCH				
CP304	Wafer, 2P	L021020832310	1	
SW751	Tact Sw	G180040500010	1	
PCB8 ASSEMBLY P.C. BOARD PUSH SWITCH				
CN751D	CNT PLUG, 2P	L10882P300010	1	D,RDS
SW752D	Push Power Sw	G000041810000	1	D,RDS

Ref.No.	Description	Part No.	Q'ty	Version
PCB9 ASSEMBLY P.C. BOARD ENCODER				
C351/352	Ceramic T.C Axial	820 pF	50 V	J D001821067530 2
VR351	Rotary	C49004106001A	1	
* ASSEMBLY P.C. BOARD INPUT (PCB 10, 11, 12) 7028040887600 K				
* ASSEMBLY P.C. BOARD INPUT (PCB 10, 11, 12) 7028040889000 A				
* ASSEMBLY P.C. BOARD INPUT (PCB 10, 11, 12) 7028040890400 D				
* ASSEMBLY P.C. BOARD INPUT (PCB 10, 11, 12) 7028040891800 RDS				
PCB10 ASSEMBLY P.C. BOARD INPUT				
Capacitors				
C401~410LD/R	Ceramic T.C Axial	100 pF	50 V	J D001101077530 20 D,RDS
C411	Elect GE	47 uF	25 V	M D040470084100 1
C412	Elect GE	1 uF	50 V	M D040010087100 1
C414	Elect GE	47 uF	25 V	M D040470084100 1
C417	Ceramic T.C Axial	100 pF	50 V	J D001101077530 1
C418~421	Elect GE	47 uF	25 V	M D040470084100 4
C422L/R	Elect GE	4.7 uF	50 V	M D0404R7087100 2
C423L/R	Elect GE	4.7 uF	50 V	M D0404R7087100 2
C424L/R	Elect GE	4.7 uF	50 V	M D0404R7087100 2
C425L/R	Elect GE	4.7 uF	50 V	M D0404R7087100 2
C426LD/RD	Ceramic T.C Axial	100 pF	50 V	J D001101077530 2 D,RDS
C427L/R	Ceramic T.C Axial	100 pF	50 V	J D001101077530 2
C428L/R	Elect GE	4.7 uF	50 V	M D0404R7087100 2
C429LD/RD	Ceramic H/K Axial	0.0022 uF	16 V	J D005222773530 2 D,RDS
C430L/R	Elect GE	33 uF	25 V	M D040330084100 2
C431L/R	Film Polyester	0.0018 uF	100 V	J D02018206C060 2
C432L/R	Film Polyester	0.0056 uF	100 V	J D02056206C060 2
C433L/R	Elect GE	1 uF	50 V	M D040010087100 2
C434L/R	Film Polyester	0.0018 uF	100 V	J D02018206C060 2
C435/436	Elect GE	47 uF	25 V	M D040470084100 2
C437	Ceramic H/K Axial	10000 pF	16 V	J D005103773530 1
Connectors				
CN401	B'D to B'D Wafer, 2.0mm, 11P	L101352371110	1	
CN402	B'D to B'D Wafer, 2.0mm, 8P	L101352370810	1	
Diodes				
D401	1N4148M, Switching	K000414801520	1	
Integrated Circuits				
IC401	LC7821, Logic	J040782100010	1	
IC402~404	KIA4559, Linear OP	J121455900010	3	
Coils				
L401LD/RD	Filter Inductor, 47 uH	D330470001020	2	
Resistors				
R401L/R	Metal Film	470 ohm	1/5 W	J C06004716P520 2
R402L/R	Metal Film	470 ohm	1/5 W	J C06004716P520 2
R403L/R	Metal Film	470 ohm	1/5 W	J C06004716P520 2
R404L/R	Metal Film	470 ohm	1/5 W	J C06004716P520 2
R405L/R	Metal Film	1 kohm	1/5 W	J C06001026P520 2
R406	Metal Film	220 ohm	1/5 W	J C06002216P520 1
R407	Carbon Film	100 kohm	1/5 W	J C00001046P520 1
R408~412	Metal Film	220 ohm	1/5 W	J C06002216P520 5
R413~415	Metal Film	1 kohm	1/5 W	J C06001026P520 3
R416L/R	Carbon Film	100 kohm	1/5 W	J C00001046P520 2
R417L/R	Carbon Film	100 kohm	1/5 W	J C00001046P520 2
R418L/R	Carbon Film	100 kohm	1/5 W	J C00001046P520 2
R419L/R	Carbon Film	100 kohm	1/5 W	J C00001046P520 2
R420L/R	Metal Film	1 kohm	1/5 W	J C06001026P520 2
R421L/R	Carbon Film	91 kohm	1/5 W	J C00009136P520 2
R422L/R	Carbon Film	91 kohm	1/5 W	J C00009136P520 2
R423L/R	Metal Film	820 ohm	1/5 W	J C06008216P520 2
R424L/R	Carbon Film	43 kohm	1/5 W	J C00004336P520 2
R425L/R	Carbon Film	560 kohm	1/5 W	J C00005646P520 2
R426L/R	Metal Film	560 ohm	1/5 W	J C06005616P520 2
R427L/R	Carbon Film	100 kohm	1/5 W	J C00001046P520 2
R428/429	Metal Film	220 ohm	1/5 W	J C06002216P520 2
R430L/R	Metal Film	1 kohm	1/5 W	J C06001026P520 2
R431L/R	Metal Film	1 kohm	1/5 W	J C06001026P520 2
R432	Carbon Film	100 kohm	1/5 W	J C00001046P520 1
R433L/R	Metal Film	470 ohm	1/5 W	J C06004716P520 2
R434L/R	Metal Film	470 ohm	1/5 W	J C06004716P520 2
R435L/R	Carbon Film	47 kohm	1/5 W	J C00004736P520 2
R436	Carbon Film	100 kohm	1/5 W	J C00001046P520 1

Ref.No.	Description	Part No.	Q'ty	Version
PCB11 ASSEMBLY P.C. BOARD INPUT & VIDEO				
Capacitors				
C450~458LD/RD	Ceramic T.C Axial	100 pF	50 V	J D001101077530 20
C460	Elect GE	47 uF	25 V	M D040470084100 1
C461	Elect GE	1 uF	50 V	M D040010087100 1
C463	Elect GE	47 uF	25 V	M D040470084100 1
C466~469	Ceramic T.C Axial	100 pF	50 V	J D001101077530 4
C470	Ceramic H/K Axial	0.1 uF	50 V	Z D005104097530 1
C471	Elect GE	47 uF	25 V	M D040470084100 1
C472	Elect GE	10 uF	50 V	M D040100087100 1
C473	Elect GE	47 uF	25 V	M D040470084100 1
C474/475	Elect GE	10 uF	50 V	M D040100087100 2
C477	Elect GE	470 uF	10 V	M D040471082100 1
C478	Ceramic H/K Axial	0.1 uF	50 V	Z D005104097530 1
C479	Elect GE	33 uF	25 V	M D040330084100 1
C480	Elect GE	470 uF	10 V	M D040471082100 1
C481	Elect GE	33 uF	25 V	M D040330084100 1
C482	Elect GE	470 uF	10 V	M D040471082100 1
C483/484	Elect GE	33 uF	25 V	M D040330084100 2
Connectors				
CN451	B'D to B'D Wafer, 2.0mm, 16P	L101352371610	1	
CP601	Wafer, 2.0mm, 5P	L101220050000	1	
Diodes				
D450/451	1N4148M, Switching	K000414801520	2	
Integrated Circuits				
IC450	LC7821, Logic	J040782100010	1	
IC451	BA7625, Video SW	J171762500000	1	
IC452	MC14053, Logic	J040140530000	1	
IC453	MC14094, Logic	J040140940000	1	
Q450/451	BKTA1267, PNP	J5001267Y0050	2	
Resistors				
R451L/R	Metal Film	470 ohm	1/5 W	J C06004716P520 2
R452L/R	Metal Film	470 ohm	1/5 W	J C06004716P520 2
R453L/R	Metal Film	470 ohm	1/5 W	J C06004716P520 2
R454L/R	Metal Film	470 ohm	1/5 W	J C06004716P520 2
R455L/R	Metal Film	470 ohm	1/5 W	J C06004716P520 2
R456	Metal Film	220 ohm	1/5 W	J C06002216P520 1
R457	Carbon Film	100 kohm	1/5 W	J C00001046P520 1
R458~463	Metal Film	1 kohm	1/5 W	J C06001026P520 6
R464~469	Metal Film	3.3 kohm	1/5 W	J C06003326P520 6
R470	Metal Film	220 ohm	1/5 W	J C06002216P520 1
R471/472	Metal Film	100 ohm	1/5 W	J C06001016P520 2
R473~478	Metal Film	75 ohm	1/5 W	J C06007506P520 6
R479/480	Metal Film	100 ohm	1/5 W	J C06001016P520 2
PCB12 ASSEMBLY P.C. BOARD SPEAKER				
Capacitors				
C901L/R/C	Film Polyester	0.047 uF	100 V	J D02047306C060 3
C901SL/SR	Film Polyester	0.047 uF	100 V	J D02047306C060 2
C902LD/RD/CD	Ceramic H/K Axial	4700 pF	16 V	J D005472773530 3
C902SLD/SRD	Ceramic H/K Axial	4700 pF	16 V	J D005472773530 2
C903LD/RD/CD	Ceramic H/K Axial	4700 pF	16 V	J D005472773530 3
C903SLD/SRD	Ceramic H/K Axial	4700 pF	16 V	J D005472773530 2
Resistors				
R901L/R/C	Metal Film	10 ohm	2 W	J C060010066520 3
R901SL/SR	Metal Film	10 ohm	2 W	J C060010066520 2
R902SL/SR	Metal Film	10 ohm	1 W	J C060010066520 2
Miscellaneous				
CP701OUT	B'D to B'D Wafer, 2.5mm, 4P	L104353130400	1	
CN901	Wafer, 3.96mm, 11P	L102526681110	1	
L901SL/SR	Coil, Filter Inductor, 0.5 uH	D330900001320	2	
PCB13 ASSEMBLY P.C. BOARD PROCESSOR 7028040888000 K				
PCB14 ASSEMBLY P.C. BOARD PROCESSOR 7028040889400 A				
PCB15 ASSEMBLY P.C. BOARD PROCESSOR 7028040890800 D				
PCB16 ASSEMBLY P.C. BOARD PROCESSOR 7028040892200 RDS				
Capacitors				
C501L/R	Film Polyester	0.1 uF	63 V	J D020104068050 2
C502L/R	Film Polyester	0.1 uF	63 V	J D020104068050 2

Ref.No.	Description	Part No.	Q'ty	Version
C503L/R	Ceramic Chip T.C	100 pF	50 V	D010101167210 2
C504L/R	Elect GE	2.2 uF	50 V	M D0402R2087100 2
C505L/R	Elect GE	2.2 uF	50 V	M D0402R2087100 2
C506L/R	Elect GE	4.7 uF	50 V	M D0404R7087100 2
C507	Ceramic Chip T.C	100 pF	50 V	D010101167210 1
C508L/R	Elect GE	4.7 uF	50 V	M D0404R7087100 2
C509L/R	Ceramic Chip T.C	100 pF	50 V	D010101167210 2
C510L/R	Elect GE	0.47 uF	50 V	M D040R47087100 2
C511L/R	Ceramic Chip T.C	22 pF	50 V	D010220167210 2
C512L/R	Elect GE	4.7 uF	50 V	M D0404R7087100 2
C513L/R	Ceramic Chip T.C	0.1 uF	50 V	D011104597210 2
C514L/R	Elect GE	4.7 uF	50 V	M D0404R7087100 2
C518	Elect GE	4.7 uF	25 V	M D040470084100 1
C517L/R	Elect GE	10 uF	50 V	M D040100087100 2
C518LD/RD	Ceramic T.C Axial	100 pF	50 V	J D001101077530 2
C519	Elect GE	47 uF	25 V	M D040470084100 1
C520	Elect GE	1 uF	50 V	M D040010087100 1
C521~523	Elect GE	47 uF	25 V	M D040470084100 3
C524	Ceramic Chip T.C	100 pF	50 V	D010101167210 1
C525	Elect GE	2.2 uF	50 V	M D0402R2087100 1
C528	Film Polyester	0.1 uF	63 V	J D020104068050 1
C527	Film Polyester	0.1 uF	63 V	J D020104068050 1
C528	Ceramic Chip T.C	100 pF	50 V	D010101167210 1
C529	Elect GE	2.2 uF	50 V	M D0402R2087100 1
C530/531	Elect GE	4.7 uF	50 V	M D0404R7087100 2
C532	Ceramic Chip T.C	100 pF	50 V	D010101167210 1
C533	Ceramic Chip T.C	0.1 uF	50 V	D011104597210 1
C534	Elect GE	0.47 uF	50 V	M D040R47087100 1
C535	Ceramic Chip T.C	22 pF	50 V	D010220167210 1
C536/537	Elect GE	4.7 uF	50 V	M D0404R7087100 2
C538/539	Ceramic Chip T.C	100 pF	50 V	D010101167210 2
C540	Elect GE	10 uF	50 V	M D040100087100 1
C541D/542	Ceramic T.C Axial	100 pF	50 V	J D001101077530 2
C543LD/RD	Ceramic T.C Axial	100 pF	50 V	J D001101077530 2
C544L/R	Film Polyester	0.1 uF	63 V	J D020104068050 2
C545L/R	Film Polyester	0.1 uF	63 V	J D020104068050 2
C548L/R	Ceramic Chip T.C	100 pF	50 V	D010101167210 2
C547L/R	Elect GE	2.2 uF	50 V	M D0402R2087100 2
C548L/R	Elect GE	2.2 uF	50 V	M D0402R2087100 2
C549L/R	Elect GE	2.2 uF	50 V	M D0402R2087100 2
C550L/R	Ceramic Chip T.C	100 pF	50 V	D010101167210 2
C551L/R	Elect GE	2.2 uF	50 V	M D0402R2087100 2
C552L/R	Ceramic Chip T.C	100 pF	50 V	D010101167210 2
C553L/R	Ceramic Chip T.C	0.1 uF	50 V	D011104597210 2
C554L/R	Elect GE	0.47 uF	50 V	M D040R47087100 2
C555L/R	Ceramic Chip T.C	22 pF	50 V	D010220167210 2
C556L/R	Elect GE	4.7 uF	50 V	M D0404R7087100 2
C557L/R	Ceramic Chip T.C	100 pF	50 V	D010101167210 2
C558L/R	Elect GE	4.7 uF	50 V	M D0404R7087100 2
C560L/R	Elect GE	10 uF	50 V	M D040100087100 2
C561LD/RD	Ceramic T.C Axial	100 pF	50 V	J D001101077530 2
C562	Elect GE	47 uF	25 V	M D040470084100 1
C563	Ceramic Chip T.C	100 pF	50 V	D010101167210 1
C564	Ceramic H/K Axial	0.1 uF	50 V	Z D005104097530 1
C565L/R	Ceramic Chip T.C	1000 pF	50 V	CH D010102167210 2
C566/567	Elect GE	2.2 uF	50 V	M D0402R2087100 2
C568/569	Film Polyester	0.027 uF	63 V	J D020273068050 2
C570	Elect GE	2.2 uF	50 V	M D0402R2087100 1
C571	Ceramic Chip T.C	100 pF	50 V	D010101167210 1
C572	Ceramic Chip T.C	0.1 uF	50 V	D011104597210 1
C573	Elect GE	0.47 uF	50 V	M D040R47087100 1
C574	Ceramic Chip T.C	22 pF	50 V	D010220167210 1
C575/576	Elect GE	4.7 uF	50 V	M D0404R7087100 2
C577	Ceramic Chip T.C	100 pF	50 V	D010101167210 1
C579	Elect GE	10 uF	50 V	M D040100087100 1
C580D	Ceramic T.C Axial	100 pF	50 V	J D001101077530 1
C581	Ceramic H/K Axial	0.1 uF	50 V	Z D005104097530 1
C582L/R	Ceramic H/K Axial	220 pF	50 V	J D005221077530 2
C583	Ceramic H/K Axial	220 pF	50 V	J D005221077530 1
C584	Ceramic Chip T.C	0.0056 uF	50 V	B D011562177210 1

Connectors			
CN203	CNT Assy, 220mm, 10P	L021102277320	1
CN501	B'D to B'D Wafer, 2.0mm, 19P	L101352371910	1
CN502	B'D to B'D Wafer, 2.0mm, 15P	L101352371510	1
CN503	CNT Plug, AC 1P	L103010000000	1
CP602	Wafer, 2.0mm, 9P	L101220090000	1

Diodes

Ref.No.	Description	Part No.	Q'ty	Version
D501~509	1N4148M, Switching	K000414801520	9	
D510	UZ5.1BSB ,Zener	K06005R114520	1	
Integrated Circuits				
IC501	LC7822, Analog	J080782200000	1	
IC502	MC14053, Analog	J080140530010	1	
IC503~505	LC7536, Elect VR	J084753600010	3	
IC506~508	NJM2068DD, Linear OP	J121206800000	3	
IC509/510	NJM4580L, Linear OP	J121458000030	2	
IC511/512	NJM2068DD, Linear OP	J121206800000	2	
IC513	NJM4580L, Linear OP	J121458000030	1	
IC514	NJM2068DD, Linear OP	J121206800000	1	
IC515	NJM4580L, Linear OP	J121458000030	1	
IC516/517	NJM2068DD, Linear OP	J121206800000	2	
IC518/519	NJM4580L, Linear OP	J121458000030	2	
Transistors				
Q501~504	DTA114YS, PNP	J601114YS0050	4	
Q505L/R	KTD1302, NPN	J5031302B0050	2	
Q506/507	KTD1302, NPN	J5031302B0050	2	
Q508L/R	KTD1302, NPN	J5031302B0050	2	
Q509L/R	2SK117Y	J5441170Y0050	2	
Q510L/R	2SK117Y	J5441170Y0050	2	
Resistors				
R500	Chip Thick	820 kohm 1/10 W J	C200082460200	1
R501L/R	Chip Thick	100 kohm 1/10 W J	C200010460200	2
R502L/R	Chip Thick	22 kohm 1/10 W J	C200022360200	2
R503L/R	Chip Thick	10 kohm 1/10 W J	C200010360200	2
R504L/R	Chip Thick	100 kohm 1/10 W J	C200010460200	2
R505L/R	Chip Thick	100 kohm 1/10 W J	C200010460200	2
R506L/R	Chip Thick	10 kohm 1/10 W J	C200010360200	2
R507L/R	Chip Thick	220 kohm 1/10 W J	C200022460200	2
R508L/R	Chip Thick	56 kohm 1/10 W J	C200056360200	2
R509L/R	Chip Thick	4.7 kohm 1/10 W J	C200047260200	2
R510	Chip Thick	100 kohm 1/10 W J	C200010460200	1
R511L/R	Chip Thick	470 ohm 1/10 W J	C200047160200	2
R512/513	Metal Film	47 ohm 1/5 W J	C06004706P520	2
R514L/R	Chip Thick	100 kohm 1/10 W J	C200010460200	2
R515L/R	Chip Thick	820 kohm 1/10 W J	C200082460200	2
R516L/R	Chip Thick	100 kohm 1/10 W J	C200010460200	2
R517/518	Metal Film	1 kohm 1/5 W J	C06001026P520	2
R519L/R	Chip Thick	1 kohm 1/10 W J	C200010260200	2
R520L/R	Metal Film	2.2 kohm 1/5 W J	C06002226P520	2
R521	Carbon Film	100 kohm 1/5 W J	C00001046P520	1
R522	Metal Film	47 ohm 1/5 W J	C06004706P520	1
R523	Chip Thick	100 kohm 1/10 W J	C200010460200	1
R524	Chip Thick	10 kohm 1/10 W J	C200010360200	1
R525	Chip Thick	22 kohm 1/10 W J	C200022360200	1
R526	Chip Thick	100 kohm 1/10 W J	C200010460200	1
R527	Chip Thick	1.5 kohm 1/10 W J	C200015260200	1
R528	Chip Thick	22 kohm 1/10 W J	C200022360200	1
R529/530	Chip Thick	100 kohm 1/10 W J	C200010460200	2
R531L/R	Chip Thick	1 kohm 1/10 W J	C200010260200	2
R532	Chip Thick	1 kohm 1/10 W J	C200010260200	1
R533	Metal Film	47 ohm 1/5 W J	C06004706P520	1
R534	Metal Film	2.2 kohm 1/5 W J	C06002226P520	1
R535/536	Chip Thick	100 kohm 1/10 W J	C200010460200	2
R537/538	Chip Thick	33 kohm 1/10 W J	C200033360200	2
R539	Chip Thick	10 kohm 1/10 W J	C200010360200	1
R540/541	Chip Thick	33 kohm 1/10 W J	C200033360200	2
R542	Chip Thick	5.6 kohm 1/10 W J	C200056260200	1
R543	Chip Thick	4.7 kohm 1/10 W J	C200047260200	1
R544	Chip Thick	82 kohm 1/10 W J	C200082360200	1
R545	Carbon Film	15 kohm 1/5 W J	C00001536P520	1
R546	Chip Thick	51 kohm 1/10 W J	C200051360200	1
R547L/R	Chip Thick	1 kohm 1/10 W J	C200010260200	2
R548	Chip Thick	100 kohm 1/10 W J	C200010460200	1
R549L/R	Carbon Film	3.3 Mohm 1/5 W J	C00003356P520	2
R550L/R	Carbon Film	3.3 Mohm 1/5 W J	C00003356P520	2
R551	Chip Thick	100 kohm 1/10 W J	C200010460200	1
R552	Chip Thick	1.2 kohm 1/10 W J	C200012260200	1
R553	Chip Thick	6.2 kohm 1/10 W J	C200062260200	1
R554	Chip Thick	4.7 kohm 1/10 W J	C200047260200	1
R555	Metal Film	2.2 kohm 1/5 W J	C06002226P520	1
R556L/R	Chip Thick	100 kohm 1/10 W J	C200010460200	2
R557L/R	Chip Thick	10 kohm 1/10 W J	C200010360200	2
R558L/R	Chip Thick	22 kohm 1/10 W J	C200022360200	2
R559L/R	Chip Thick	100 kohm 1/10 W J	C200010460200	2

Ref.No.	Description	Part No.	Q'ty	Version
R560L/R	Chip Thick	100 kohm 1/10 W J	C200010460200	2
R561L/R	Chip Thick	1.5 kohm 1/10 W J	C200015260200	2
R562L/R	Chip Thick	22 kohm 1/10 W J	C200022360200	2
R563L/R	Chip Thick	100 kohm 1/10 W J	C200010460200	2
R564L/R	Chip Thick	820 kohm 1/10 W J	C200082460200	2
R565L/R	Chip Thick	100 kohm 1/10 W J	C200010460200	2
R566	Chip Thick	1 kohm 1/10 W J	C200010260200	1
R567L/R	Chip Thick	1 kohm 1/10 W J	C200010260200	2
R568L/R	Chip Thick	4.7 kohm 1/10 W J	C200047260200	2
R569L/R	Metal Film	2.2 kohm 1/5 W J	C06002226P520	2
R570~573	Carbon Film	15 kohm 1/5 W J	C00001536P520	4
R574	Metal Film	2.2 kohm 1/5 W J	C06002226P520	1
R575	Carbon Film	10 kohm 1/5 W J	C00001036P520	1
R576	Metal Film	1 kohm 1/5 W J	C06001026P520	1
R577	Metal Film	1 kohm 1/5 W J	C06001026P520	1
R578	Carbon Film	10 kohm 1/5 W J	C00001036P520	1
R579	Metal Film	4.7 kohm 1/5 W J	C06004726P520	1
R580L/R	Metal Film	470 ohm 1/5 W J	C06004716P520	2
R581L/R	Metal Film	47 ohm 1/5 W J	C06004706P520	2
R582L/R	Chip Thick	560 ohm 1/10 W J	C200056160200	2
R583	Chip Thick	5.8 kohm 1/10 W J	C200058260200	1
R584	Chip Thick	3.9 kohm 1/10 W J	C200039260200	1
R585	Metal Film	47 ohm 1/5 W J	C06004706P520	1
R586	Chip Thick	33 kohm 1/10 W J	C200033360200	1
R587	Metal Film	4.7 kohm 1/5 W J	C06004726P520	1
R588	Chip Thick	1 kohm 1/10 W J	C200010260200	1
R589L/R	Chip Thick	100 kohm 1/10 W J	C200010460200	2
R590	Chip Thick	4.7 kohm 1/10 W J	C200047260200	1
R591	Metal Film	47 ohm 1/5 W J	C06004706P520	1
R592L/R	Chip Thick	3.9 kohm 1/10 W J	C200039260200	2
R593	Chip Thick	820 kohm 1/10 W J	C200082460200	1

PCB14	ASSEMBLY P.C. BOARD AC-3	7028040888200	K
PCB14	ASSEMBLY P.C. BOARD AC-3	7028040889600	A
PCB14	ASSEMBLY P.C. BOARD AC-3	7028040891000	D
PCB14	ASSEMBLY P.C. BOARD AC-3	7028040892400	RDS

Capacitors			
C801	Ceramic Chip T.C	0.022 uF	25 V Z D011223177210 1
C802~804	Ceramic Chip T.C	0.1 uF	50 V Z D011104177210 3
C805	Elect GE	47 uF	25 V M D040470084100 1
C806	Ceramic Chip T.C	0.1 uF	50 V Z D011104177210 1
C807	Elect GE	47 uF	25 V M D040470084100 1
C808	Ceramic Chip T.C	75 pF	50 V CH D010750167210 1
C809	Ceramic Chip T.C	0.01 uF	50 V J D011103177210 1
C810/811	Ceramic Chip T.C	0.1 uF	50 V Z D011104177210 2
C812	Ceramic Chip T.C	0.01 uF	50 V J D011103177210 1
C813	Ceramic Chip T.C	0.001 pF	50 V CH D010102167210 1
C814	Elect GE	1 uF	50 V M D040010087100 1
C815	Ceramic Chip T.C	0.1 uF	50 V Z D011104177210 1
C816	Elect GE	47 uF	25 V M D040470084100 1
C817	Elect GE	1 uF	50 V M D040010087100 1
C818	Elect GE	47 uF	25 V M D040470084100 1
C819~821			

Ref.No.	Description	Part No.	Q'ty	Version	
C853	Elect GE	47 uF	25 V	M D040470084100	1
C854	Ceramic Chip T.C	0.01 uF	50 V	J D011103177210	1
C854CAW	Elect GE	10 uF	50 V	M D040100087100	2
C855	Elect GE	100 uF	10 V	M D040101082100	1
C857	Ceramic Chip T.C	22 pF	50 V	CH D010220167210	1
C858	Ceramic Chip T.C	0.01 uF	50 V	J D011103177210	1
C859/860	Ceramic Chip T.C	0.1 uF	50 V	Z D011104177210	2
C860SL/SR	Ceramic Chip T.C	0.0015 uF	50 V	CH D011152177210	2
C861/862	Elect GE	3.3 uF	50 V	M D0403R3087100	2
C863L/R	Ceramic Chip T.C	0.0015 uF	50 V	B D011152177210	2
C864	Elect GE	47 uF	25 V	M D040470084100	1
C865CAW	Ceramic Chip T.C	0.0015 uF	50 V	B D011152177210	2
C866SL/SR	Elect GE	10 uF	50 V	M D040100087100	2
C867	Elect GE	47 uF	25 V	M D040470084100	1
C868SL/SR	Ceramic Chip T.C	0.0015 uF	50 V	B D011152177210	2
C869-875	Ceramic Chip T.C	0.1 uF	50 V	Z D011104177210	7
C876	Elect GE	1 uF	50 V	M D040010087100	1
C877L/R/CAW	Ceramic Chip T.C	0.0047 uF	50 V	B D011472177210	4
C877SL/SR	Ceramic Chip T.C	0.0047 uF	50 V	B D011472177210	2
C880/881	Elect GE	10 uF	35 V	M D040100085100	2
C882-891	Ceramic Chip T.C	0.1 uF	50 V	Z D011104177210	10
C892	Elect BP	47 uF	10 V	M D042470082110	1
C893	Elect GE	10 uF	50 V	M D040100087100	1
C894-896	Ceramic Chip T.C	0.01 uF	50 V	J D011103177210	3
C897	Elect GE	1 uF	50 V	M D040010087100	1
Coils					
L801/802	Filter Inductor, 68 uH			D330680001020	2
L803-805	BEAD, Chip-Type			7811010000000	3
Connectors					
CN801	8'D to B'D Wafer, 2.0mm, 11P			L101352371110	1
CN802	B'D to B'D Wafer, 2.0mm, 14P			L101352371410	1
Diodes					
D801-805	RLS4148, Switching			K009573221000	5
VC101	KV1851, Varactor			K0801851000010	1
Integrated Circuits					
IC801	MC14577BP, Monitor			J170145770000	1
IC802	NJM2068M, Linear OP			J121206800020	1
IC803	PM4007A, Analog			J080400700010	1
IC804	KM68257CJ, Memory RAM			J001682510010	1
IC805	NJM2068M, Linear OP			J121206800020	1
IC806	CS4226, Analog			J080422600010	1
IC807	MC56009F, Analog			J080560098110	1
IC808	74HC76, Logic			J040747600040	1
IC809	74HCU04, Logic			J040740400020	1
IC810	uPD78044			J020828521220	1
IC811/812	HY534256, Memory RAM			J001534256000	2
IC813	74HC04, Logic			J0407404000210	1
IC814-816	NJM2068M, Linear OP			J121206800020	3
Transistors					
Q801/802	2SC1740S, NPN			J5021740S0010	2
Q803/804	2SA933S, PNP			J5000933S0050	2
Q805/806	2SC1740S, NPN			J5021740S0010	2
Q807	DTC114TS, PNP			J600114TS0050	1
Q808	DTA114YS, PNP			J601114YS0050	1
Q809L/R	DTC323TK, NPN			J502323000050	2
Q810CAW	DTC323TK, NPN			J502323000050	2
Q811SL/SR	DTC323TK, NPN			J502323000050	2
Q812	DTC114YS, NPN			J6020114Y0050	1
Resistors					
R750	Chip Thick	100 kohm	1/10 W	J C200010460200	1
R750CAW	Chip Thick	100 kohm	1/10 W	J C200010460200	2
R751	Chip Thick	220 kohm	1/10 W	J C200022460200	1
R752L/R	Chip Thick	100 ohm	1/10 W	J C200010160200	2
R753L/R	Chip Thick	3.3 kohm	1/10 W	J C200033260200	2
R754	Chip Thick	3.3 kohm	1/10 W	J C200033260200	1
R754L/R	Chip Thick	100 kohm	1/10 W	J C200010460200	2
R755L/R	Chip Thick	1 kohm	1/10 W	J C200010260200	2
R756/757	Chip Thick	15 ohm	1/10 W	J C200015060200	2
R758CAW	Chip Thick	100 ohm	1/10 W	J C200010160200	2
R759CAW	Chip Thick	3.3 kohm	1/10 W	J C200033260200	2
R761CAW	Chip Thick	1 kohm	1/10 W	J C200010260200	2
R762L/R/CAW	Chip Thick	3.3 kohm	1/10 W	J C200033260200	4

Ref.No.	Description	Part No.	Q'ty	Version	
R763CAW	Chip Thick	3.3 kohm	1/10 W	J C200033260200	2
R764SL/SR	Chip Thick	3.3 kohm	1/10 W	J C200033260200	2
R766SL/SR	Chip Thick	100 ohm	1/10 W	J C200010160200	2
R767SL/SR	Chip Thick	3.3 kohm	1/10 W	J C200033260200	2
R768SL/SR	Chip Thick	100 kohm	1/10 W	J C200010460200	2
R769SL/SR	Chip Thick	1 kohm	1/10 W	J C200010260200	2
R770L/R/CAW	Chip Thick	2.2 kohm	1/10 W	J C200022260200	4
R771CAW	Chip Thick	2.2 kohm	1/10 W	J C200022260200	2
R772SL/SR	Chip Thick	2.2 kohm	1/10 W	J C200022260200	2
R774	Chip Thick	470 ohm	1/10 W	J C200047160200	1
R775	Chip Thick	4.7 kohm	1/10 W	J C200047260200	1
R776	Chip Thick	470 ohm	1/10 W	J C200047160200	1
R777	Chip Thick	18 kohm	1/10 W	J C200018360200	1
R778-780	Chip Thick	100 kohm	1/10 W	J C200010460200	3
R781	Carbon Film	2.2 ohm	1/4 W	J C0002R2063520	1
R782L/R/CAW	Chip Thick	100 kohm	1/10 W	J C200010460200	4
R782SL/SR	Chip Thick	100 kohm	1/10 W	J C200010460200	2
R783L/R/CAW	Chip Thick	2.2 kohm	1/10 W	J C200022260200	4
R784CAW	Chip Thick	2.2 kohm	1/10 W	J C200022260200	2
R785SL/SR	Chip Thick	2.2 kohm	1/10 W	J C200022260200	2
R786/787	Chip Thick	4.7 kohm	1/10 W	J C200047260200	2
R788L/R/CAW	Chip Thick	470 ohm	1/10 W	J C200047160200	4
789CAW	Chip Thick	470 ohm	1/10 W	J C200047160200	2
R790SL/SR	Chip Thick	470 ohm	1/10 W	J C200047160200	2
R791	Chip Thick	470 ohm	1/10 W	J C200047160200	1
R792/793	Chip Thick	22 kohm	1/10 W	J C200022360200	2
R801	Chip Thick	100 ohm	1/10 W	J C200010160200	1
R802	Metal Film	560 ohm	1/5 W	J C06005616P520	1
R803-805	Chip Thick	1 kohm	1/10 W	J C200010260200	3
R806	Chip Thick	4.7 kohm	1/10 W	J C200047260200	1
R807	Chip Thick	150 ohm	1/10 W	J C200015160200	1
R808	Chip Thick	2.2 kohm	1/10 W	J C200022260200	1
R809-812	Chip Thick	1 kohm	1/10 W	J C200010260200	4
R813	Chip Thick	10 kohm	1/10 W	J C200010360200	1
R814	Chip Thick	1 kohm	1/10 W	J C200010260200	1
R815	Chip Thick	4.7 kohm	1/10 W	J C200047260200	1
R816	Chip Thick	1 kohm	1/10 W	J C200010260200	1
R817	Chip Thick	5.1 kohm	1/10 W	J C200051260200	1
R818/819	Chip Thick	1 kohm	1/10 W	J C200010260200	2
R820	Chip Thick	1.8 kohm	1/10 W	J C200018280200	1
R821/822	Chip Thick	10 kohm	1/10 W	J C200010360200	2
R823	Chip Thick	4.7 kohm	1/10 W	J C200047260200	1
R824	Chip Thick	100 kohm	1/10 W	J C200010460200	1
R825	Chip Thick	4.7 kohm	1/10 W	J C200047260200	1
R826	Chip Thick	3.9 kohm	1/10 W	J C200039260200	1
R827	Chip Thick	22 kohm	1/10 W	J C200022360200	1
R828	Chip Thick	8.2 kohm	1/10 W	J C200082260200	1
R829	Chip Thick	88 kohm	1/10 W	J C200088360200	1
R830	Chip Thick	27 kohm	1/10 W	J C200027360200	1
R831/832	Chip Thick	10 kohm	1/10 W	J C200010360200	2
R833	Chip Thick	47 kohm	1/10 W	J C200047360200	1
R834	Chip Thick	120 ohm	1/10 W	J C200012160200	1
R835	Chip Thick	47 kohm	1/10 W	J C200047360200	1
R836	Chip Thick	470 ohm	1/10 W	J C200047160200	1
R837/838	Chip Thick	47 kohm	1/10 W	J C200047360200	2
R839/840	Chip Thick	10 kohm	1/10 W	J C200010360200	2
R841-843	Chip Thick	47 kohm	1/10 W	J C200047360200	3
R844/845	Chip Thick	10 kohm	1/10 W	J C200010360200	2
R846	Chip Thick	1 kohm	1/10 W	J C200010260200	1
R847-856	Chip Thick	47 kohm	1/10 W	J C200047360200	10
R857	Chip Thick	10 kohm	1/10 W	J C200010360200	1
R858	Chip Thick	470 ohm	1/10 W	J C200047160200	1
R859/860	Chip Thick	47 kohm	1/10 W	J C200047360200	2
R861/862	Chip Thick	100 ohm	1/10 W	J C200010160200	2
R863/864	Chip Thick	22 kohm	1/10 W	J C200022360200	2
R865	Chip Thick	5.1 kohm	1/10 W	J C200051260200	1
R866	Chip Thick	1 Mohm	1/10 W	J C200010560200	1
R867	Chip Thick	47 kohm	1/10 W	J C200047360200	1
R868/869	Chip Thick	470 ohm	1/10 W	J C200047160200	2
R870	Chip Thick	33 kohm	1/10 W	J C200033360200	1
R871-876	Chip Thick	10 kohm	1/10 W	J C200010360200	6
R878-880	Chip Thick	470 ohm	1/10 W	J C200047160200	3
R881	Chip Thick	82 ohm	1/10 W	J C200082080200	1
R882	Chip Thick	680 ohm	1/10 W	J C200068160200	1
R883	Chip Thick	4.7 kohm	1/10 W	J C200047260200	1
R884	Chip Thick	10 kohm	1/10 W	J C200010360200	1
R885-888	Chip Thick	100 kohm	1/10 W	J C200010460200	4
R889	Chip Thick	18 kohm	1/10 W	J C200018360200	1
R890-893	Chip Thick	100 kohm	1/10 W	J C200010460200	4

Ref.No.	Description	Part No.	Q'ty	Version	
R894	Chip Thick	10 kohm	1/10 W	J C200010360200	1
R895	Chip Thick	100 ohm	1/10 W	J C200010160200	1
R896-898	Chip Thick	10 kohm	1/10 W	J C200010360200	3
R899	Chip Thick	220 kohm	1/10 W	J C200022460200	1
Miscellaneous					
X801	18.432 MHz			E800184320810	1
X802	24.576 MHz			E800245760810	1
X803	Resonator, Ceramic, 4.19 MHz			E830419000060	1
BPF801	Filter, BPF, 2.88 MHz			E440000010010	1
PCB15 ASSEMBLY P.C. BOARD SUB SW-2 7028059580000 K,A,RDS					
Capacitors					
C941	Elect GE 85C	1 uF	50 V	M D040010087100	1
C942-944	Elect GE 85C	10 uF	50 V	M D040100087070	3
C945	Elect GE 85C	4.7 uF	50 V	M D0404R7087100	1
C946-952	Ceramic Hik Axial	0.001 uF	50 V	K D005102177530	7
Diodes					
D941-978	1SS133T, Switching			K000013300520	38
D980-991	1SS133T, Switching			K000013300520	12
D992/993	UZ3.3BSB, Zener			K06003R314520	2
D994	1SS133T, Switching			K000013300520	1
Integrated Circuits					
IC941-945	HEF4011B, Logic			J040401100030	5
IC946	HEF4024B, Logic			J040402400000	1
IC947-949	HEF4011B, Logic			J040401100030	3
Transistors					
Q941	DTC114TS, NPN			J600114TS0050	1
Q942-944	KTC3198, NPN			J5023198B0050	3
Q945	DTC114TS, NPN			J600114TS0050	1
Q946-948	BKTA1266, PNP			J5001266Y0050	3
Q949	DTC114TS, NPN			J600114TS0050	1
Q950	KTC3198, NPN			J5023198B0050	1
Resistors					
R941-945	Carbon Film	10 kohm	1/5 W	J C00001036P520	5
R946	Carbon Film	1 Mohm	1/5 W	J C00001056P520	1
R947	Metal Film	330 ohm	1/5 W	J C06003316P520	1
R948-950	Carbon Film	10 kohm	1/5 W	J C00001036P520	3
R951	Carbon Film	100 kohm	1/5 W	J C00001046P520	1
R952/953	Carbon Film	10 kohm	1/5 W	J C00001036P520	2
R954	Carbon Film	100 kohm	1/5 W	J C00001046P520	1
R955/956	Carbon Film	10 kohm	1/5 W	J C00001036P520	2
R957	Carbon Film	100 kohm	1/5 W	J C00001046P520	1
R958	Metal Film	1 kohm	1/5 W	J C06001026P520	1
R959	Carbon Film	10 kohm	1/5 W	J C00001036P520	1
R960	Carbon Film	18 kohm	1/5 W	J C00001836P520	1
R961/962	Carbon Film	10 kohm	1/5 W	J C00001036P520	2
R963	Metal Film	2.2 kohm	1/5 W	J C06002226P520	1
R964	Carbon Film	100 kohm			

IC FUNCTIONAL BLOCK DIAGRAM

Model No. : R-925R/R-925RDS

IC 1 : LM7001M

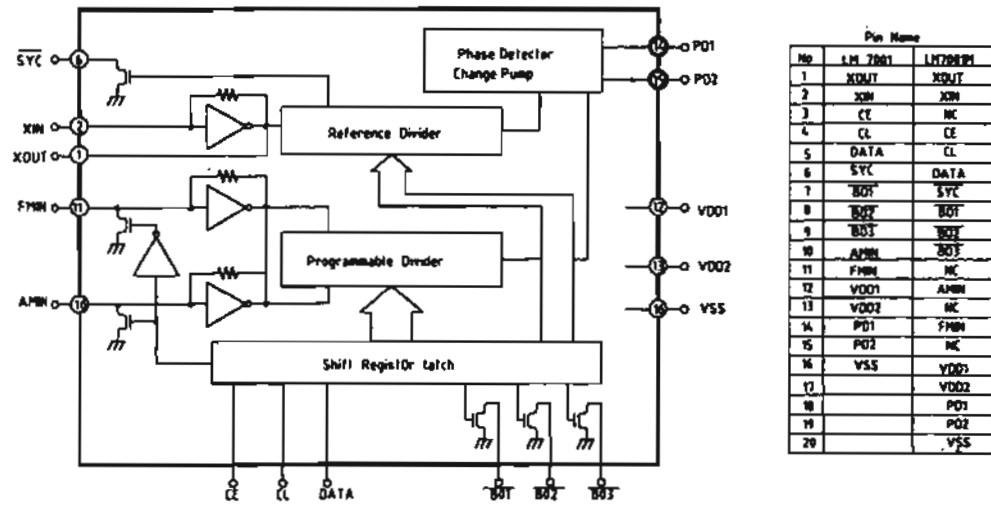

IC 451 : BA7625

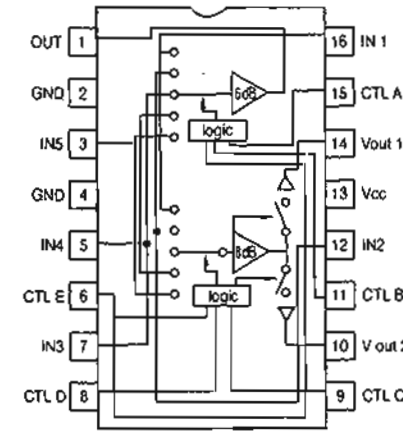

IC 452, 502 : MC14053B

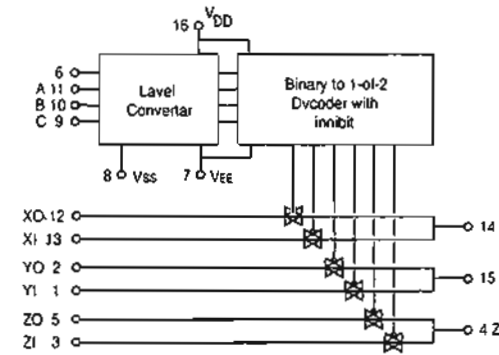

IC 503, 504, 505 : LC7536

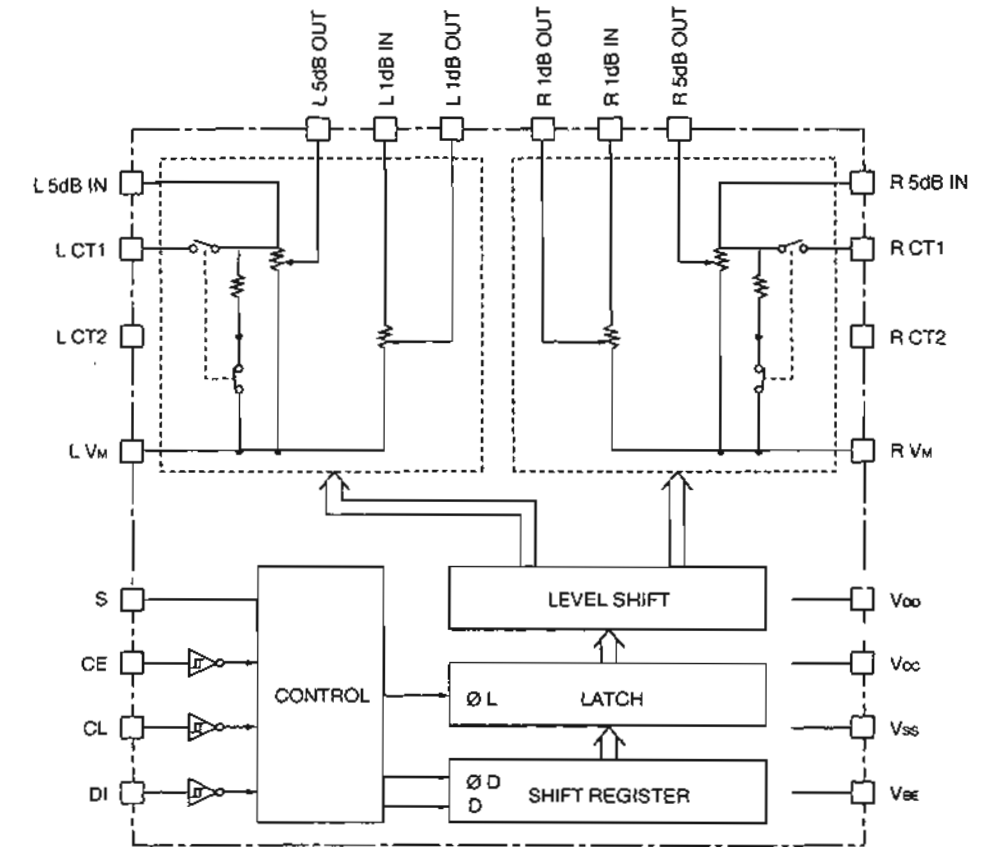

IC 453 : MC14094B

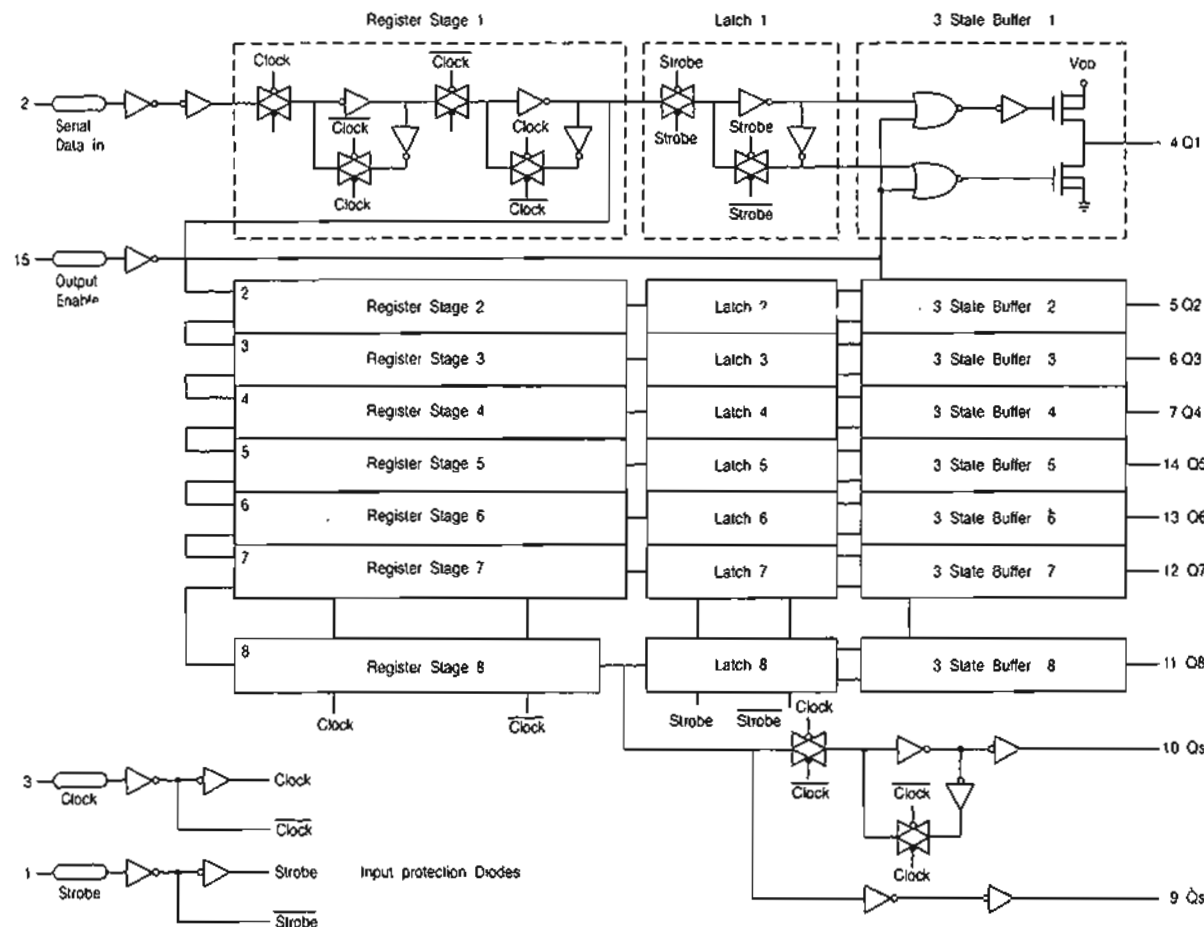

IC 401, 450 : LC7821N

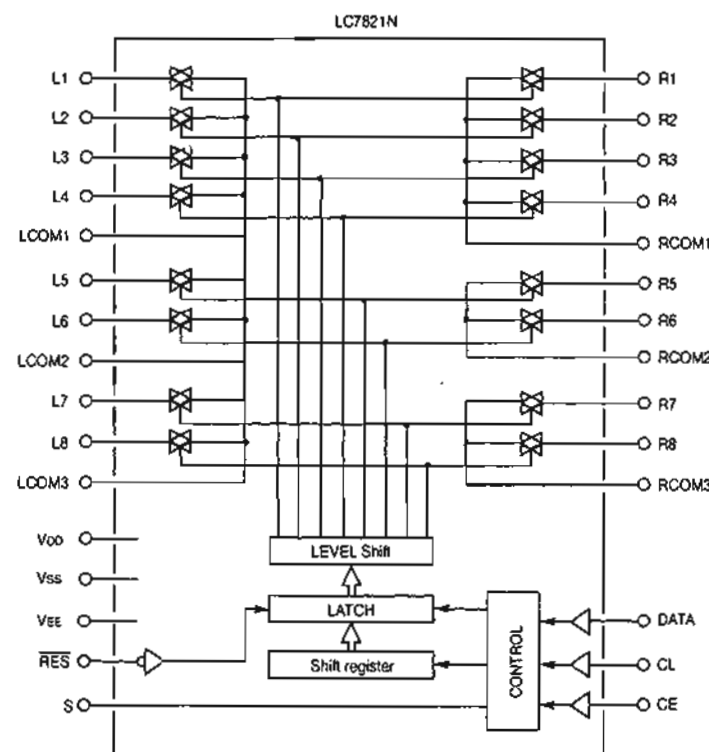

IC 501 : LC7822N

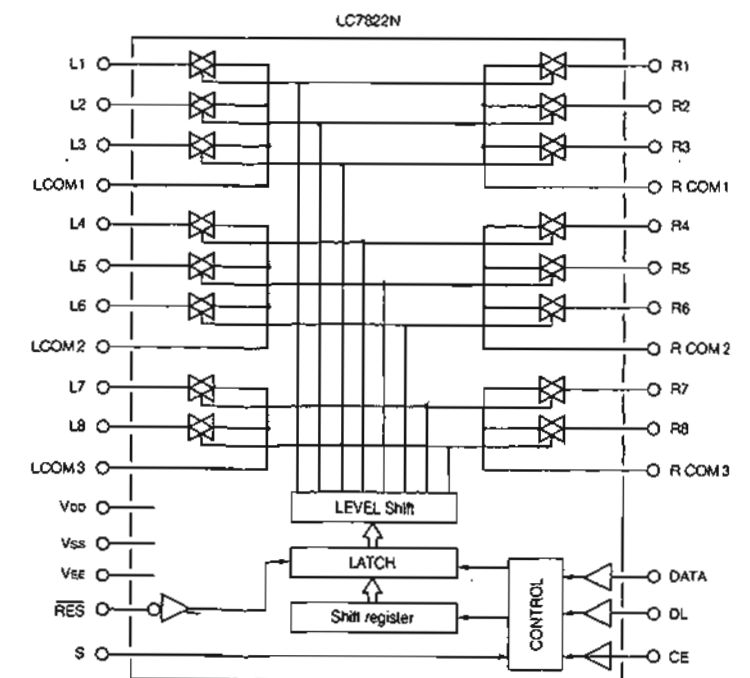

IC 806 : CS 4226

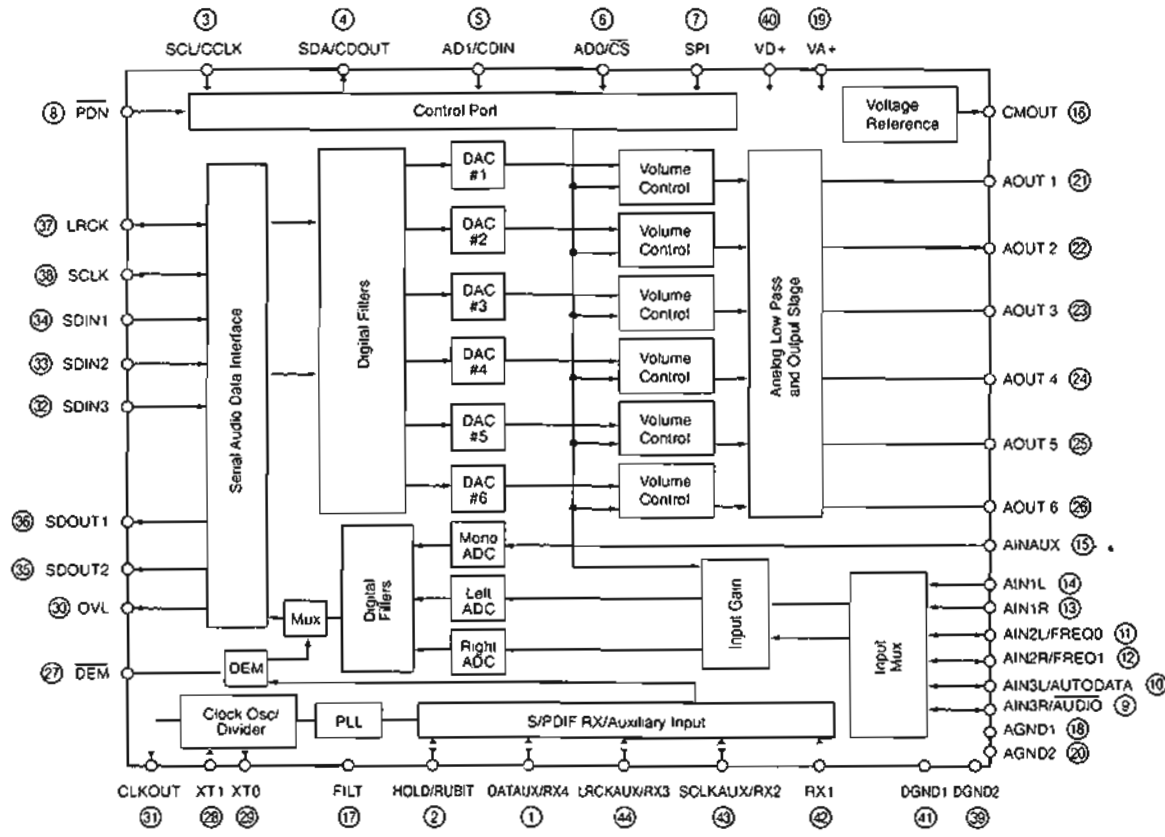

IC 810 : UPD78044A

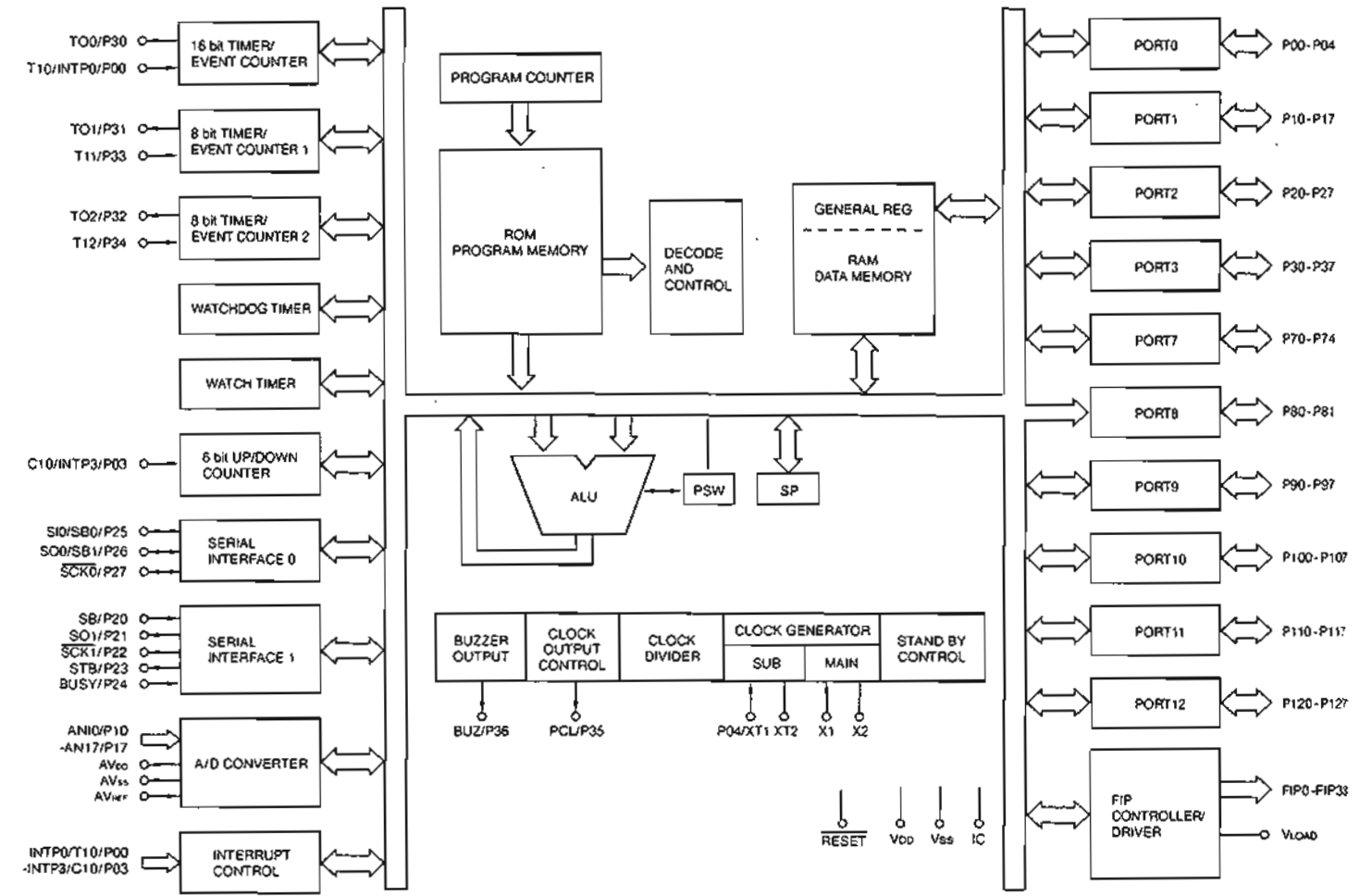

IC 804 : KM68257C

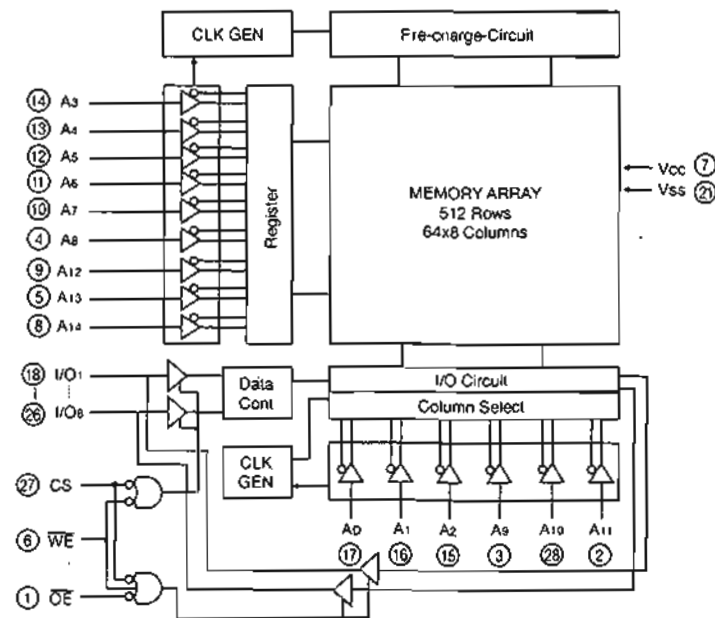

IC 811, 812 : HY534256A

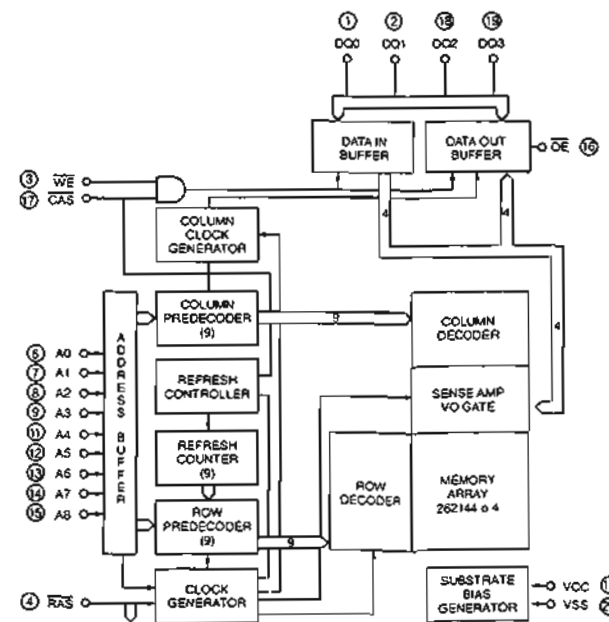

IC 808 : MC74HC76

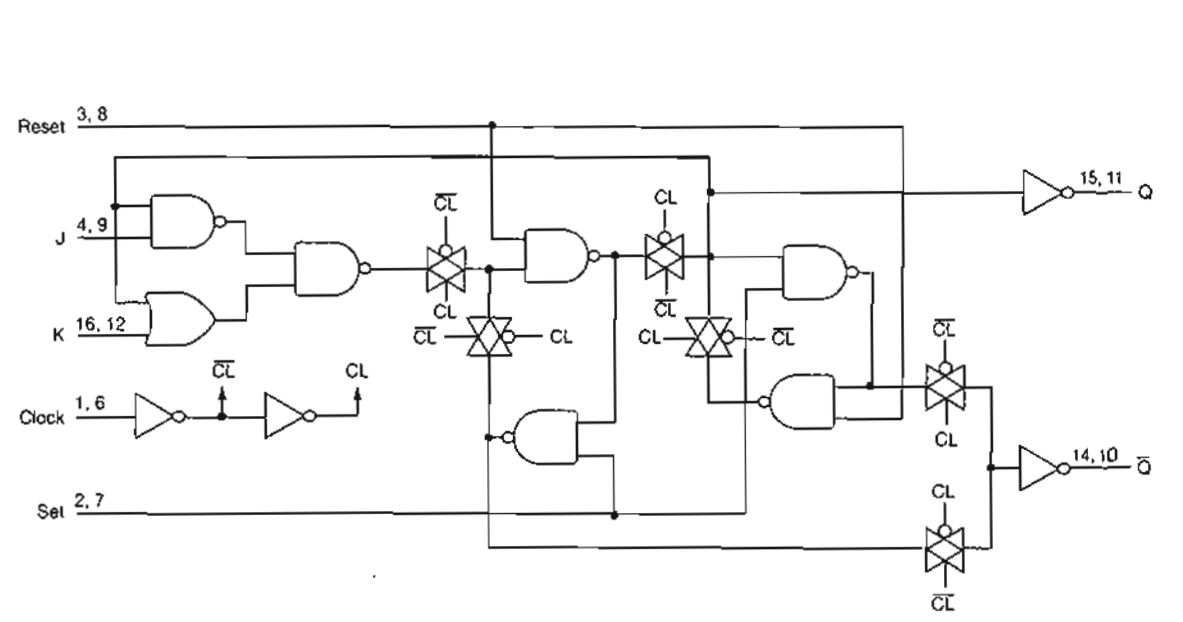

SCHEMATIC DIAGRAM (I)

Model No. : R-925R/R-925RDS

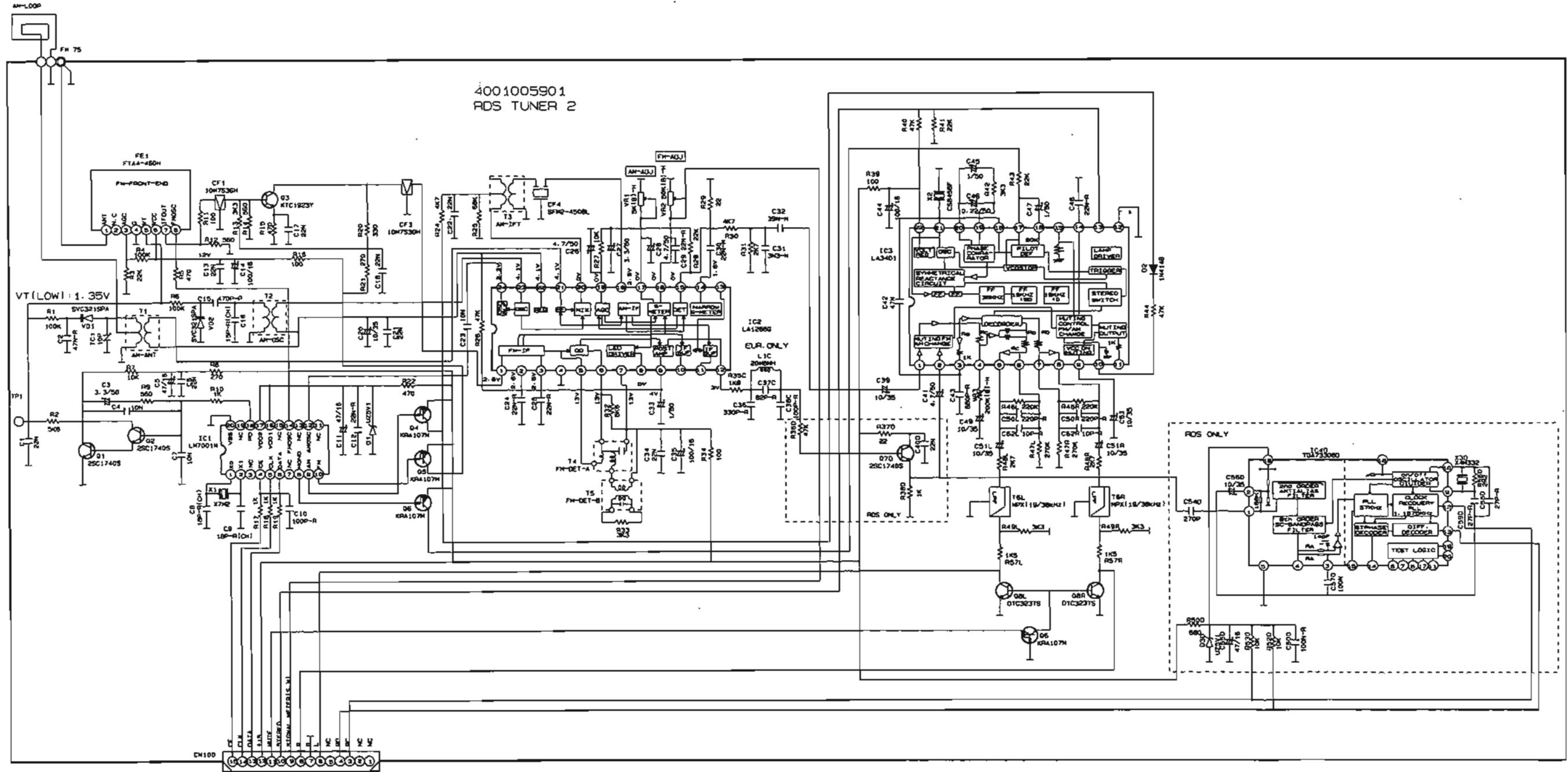

SCHEMATIC DIAGRAM (II)

Model No. : R-925R/R-925RDS

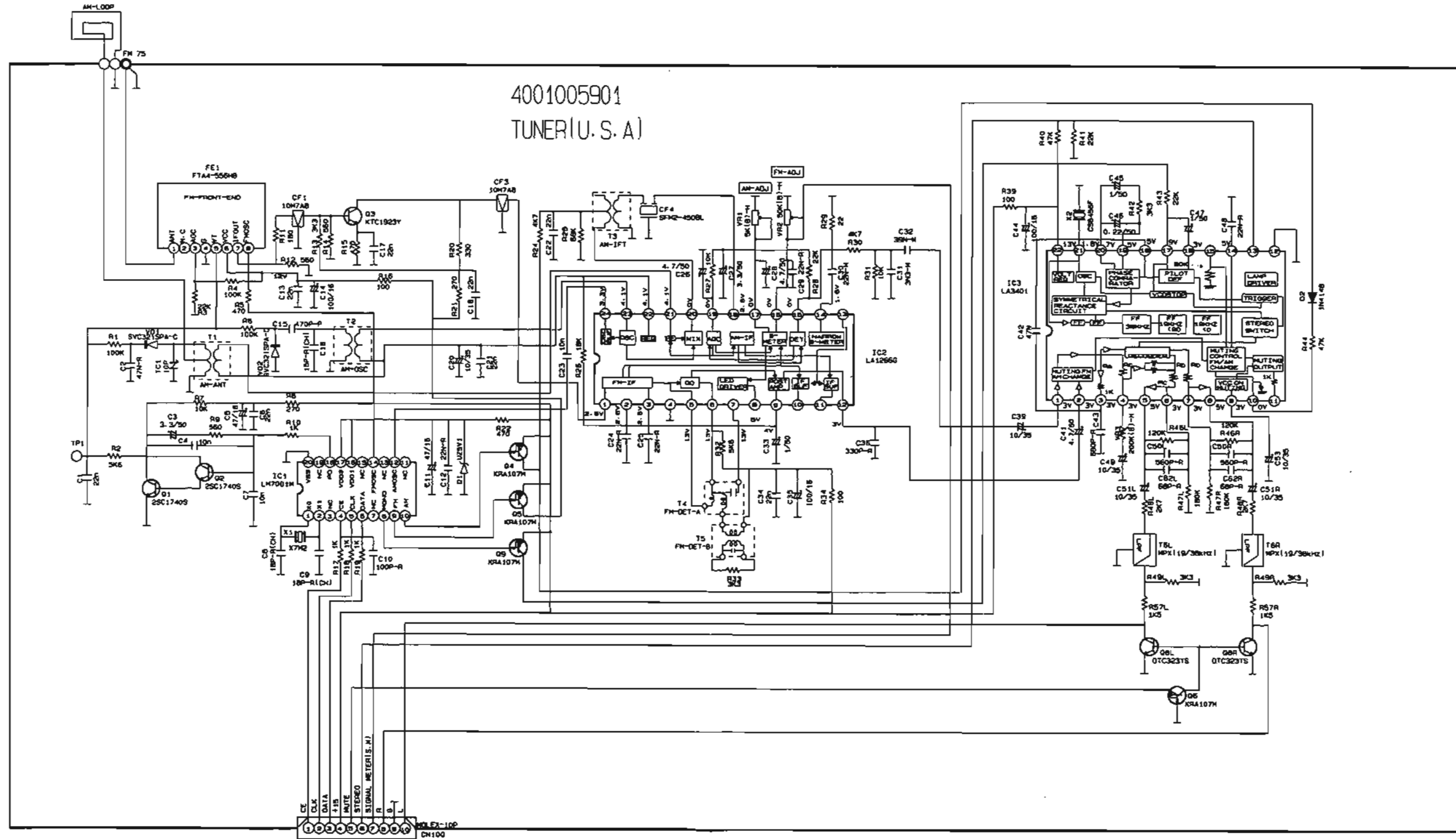

SCHEMATIC DIAGRAM (III)

Model No. : R-925R/R-925RDS

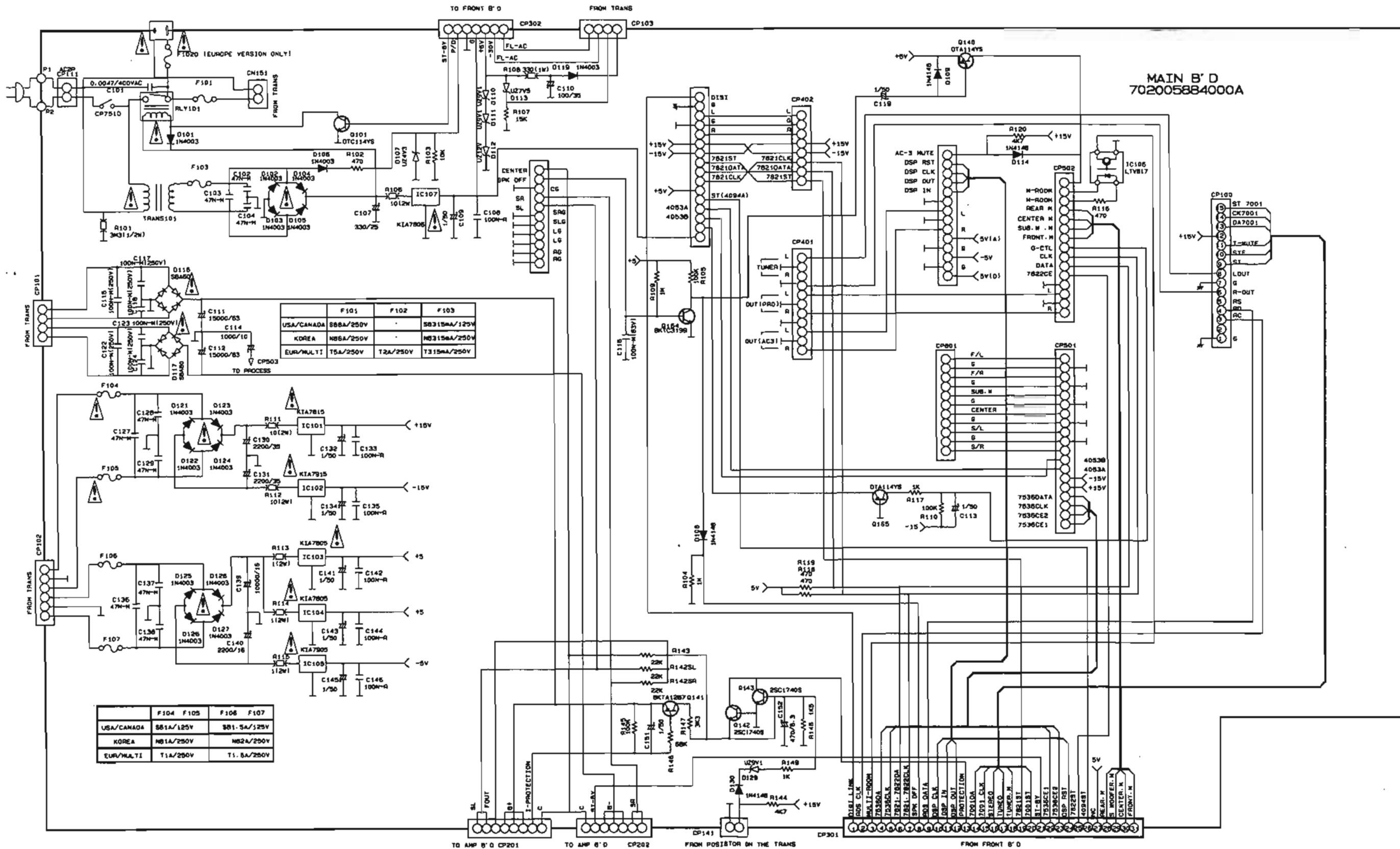

SCHEMATIC DIAGRAM (IV)

Model No. : R-925R/R-925RDS

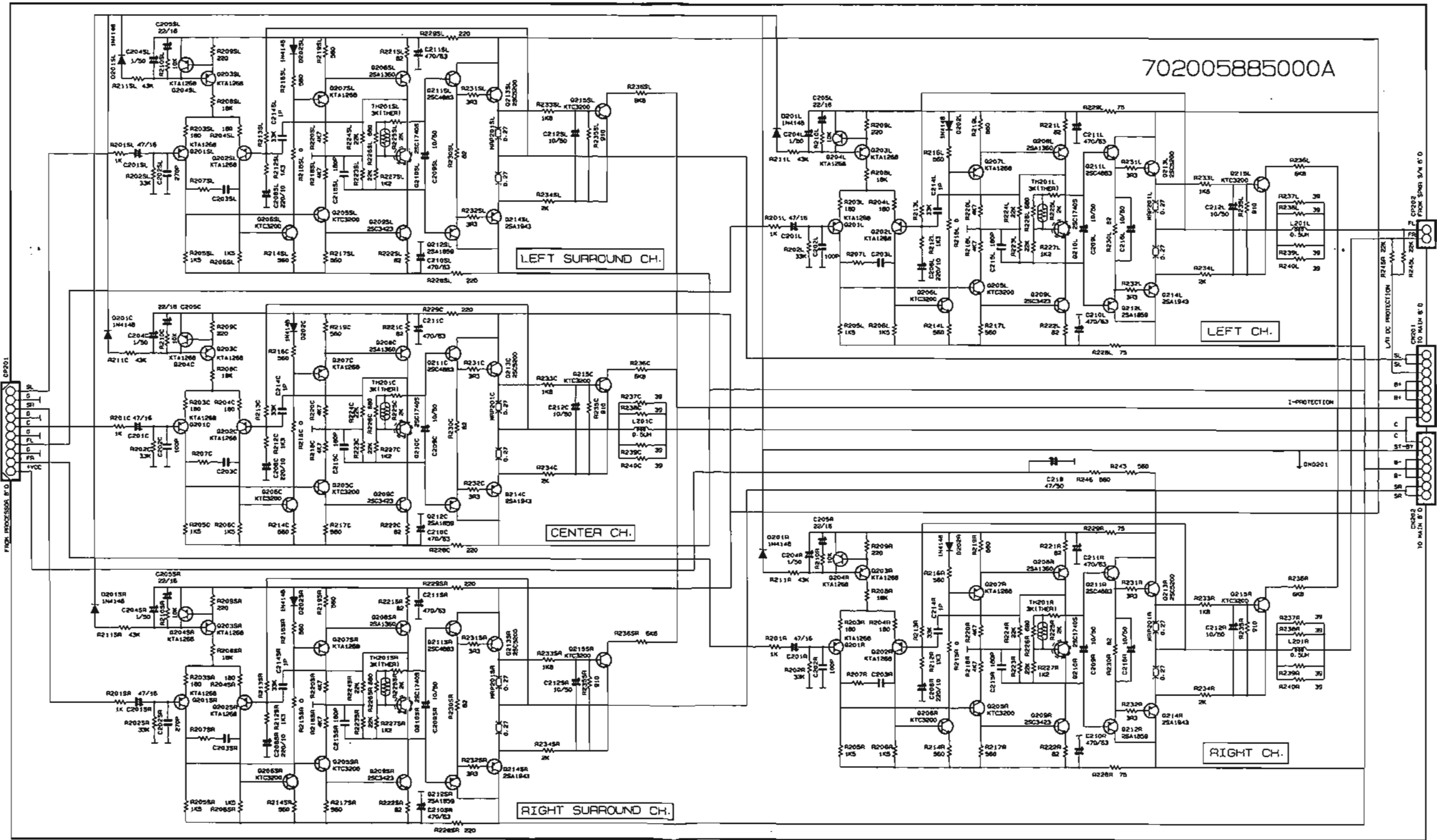

SCHEMATIC DIAGRAM (V)

Model No. : R-925R/R-925RDS

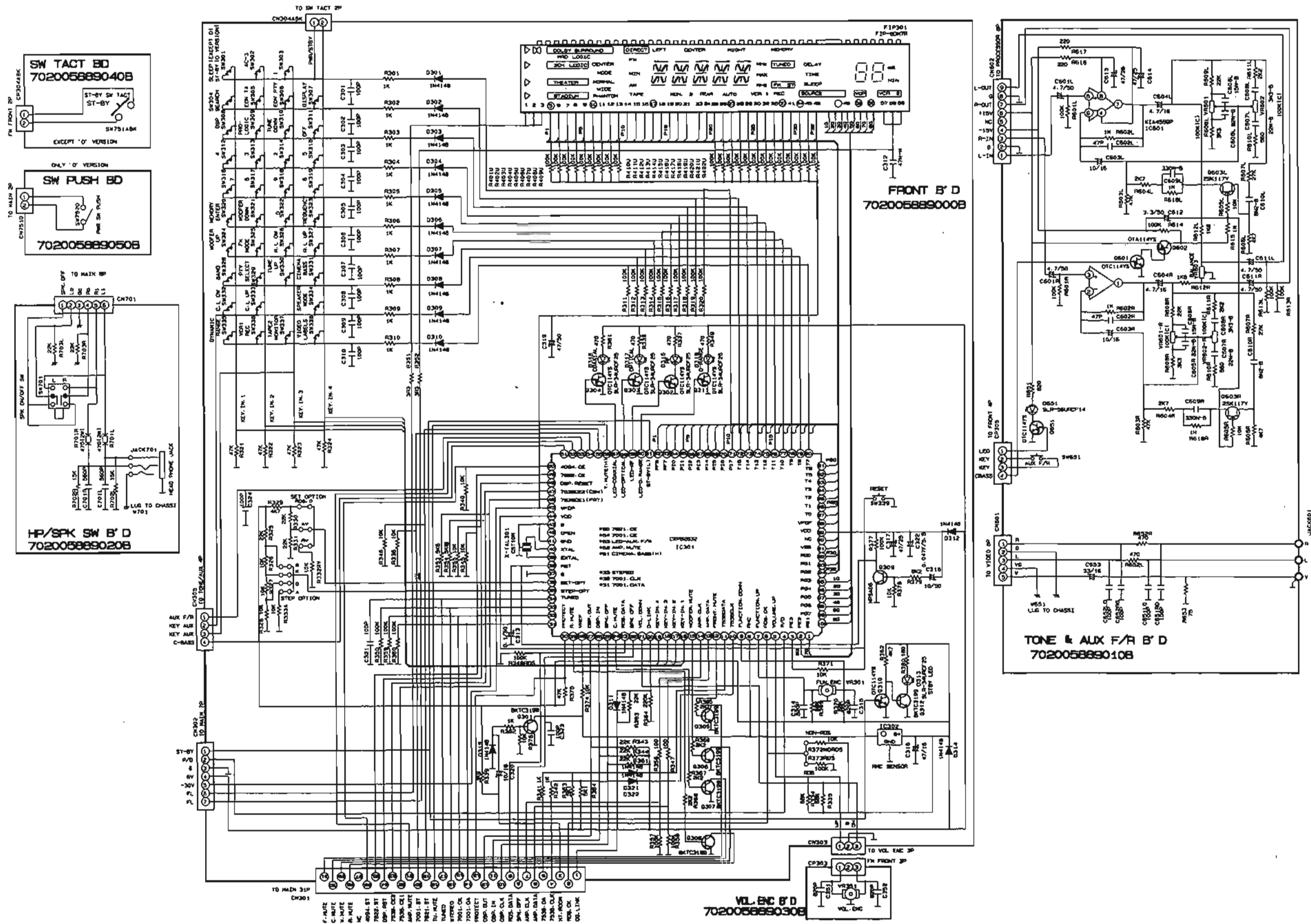

SCHEMATIC DIAGRAM (VI)

Model No. : R-925R/R-925RDS

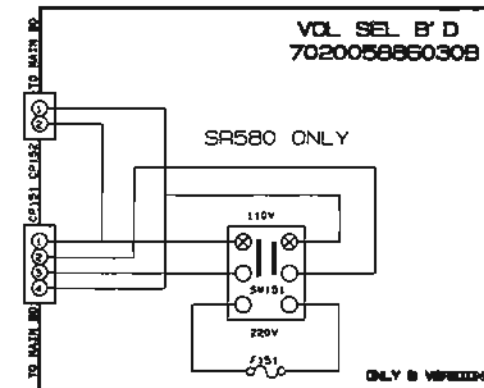
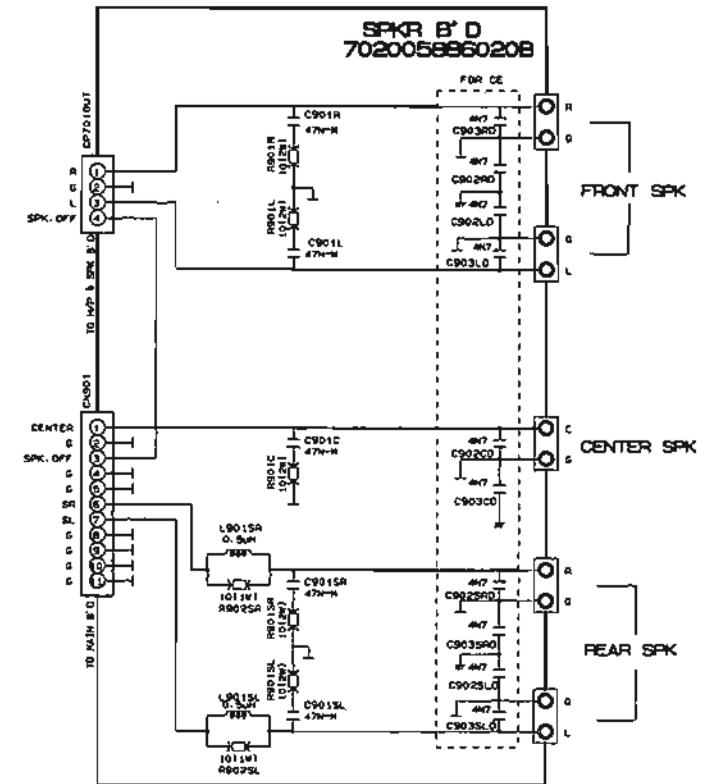
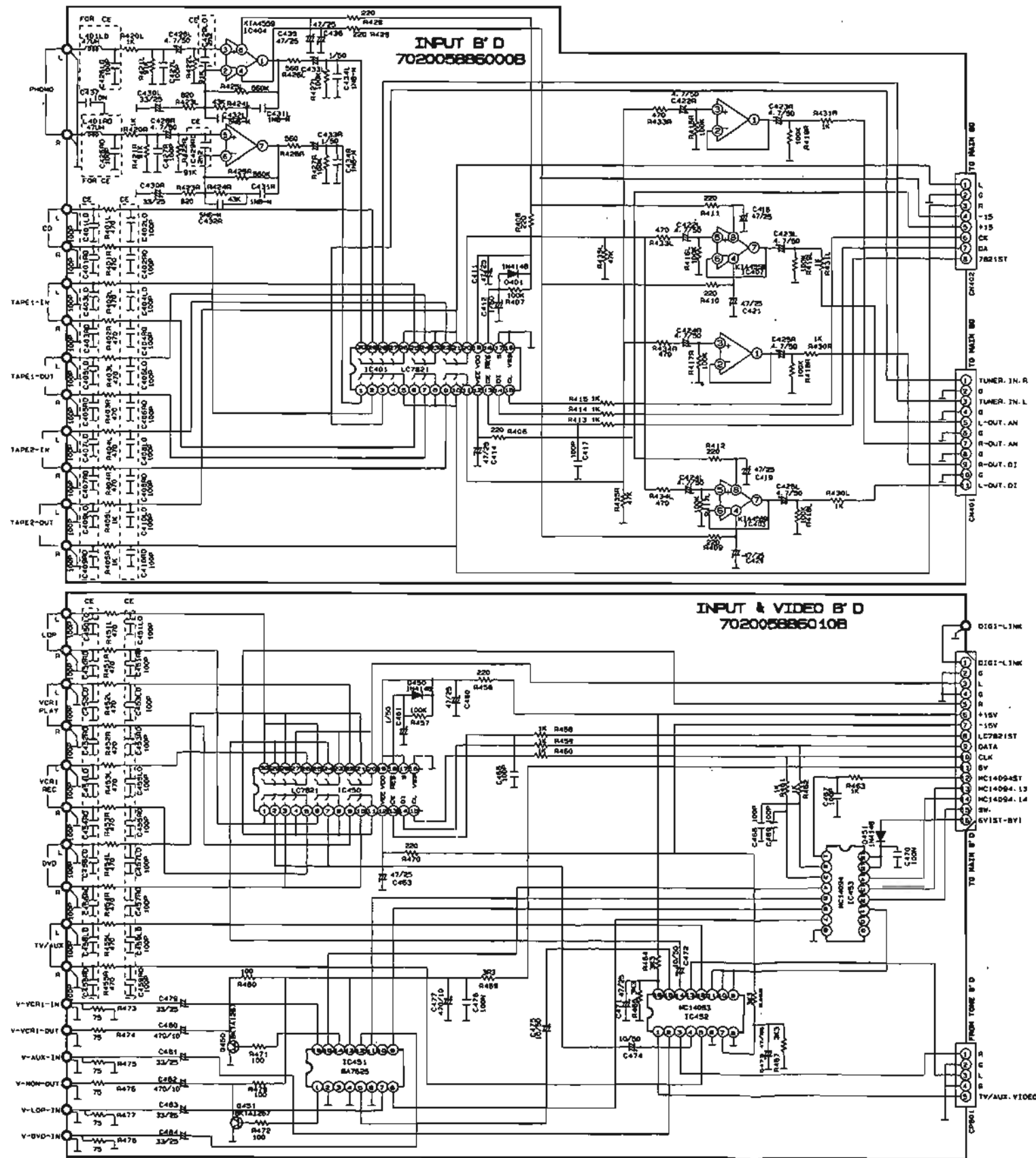

SCHEMATIC DIAGRAM (VII)

Model No. : R-925R/R-925RDS

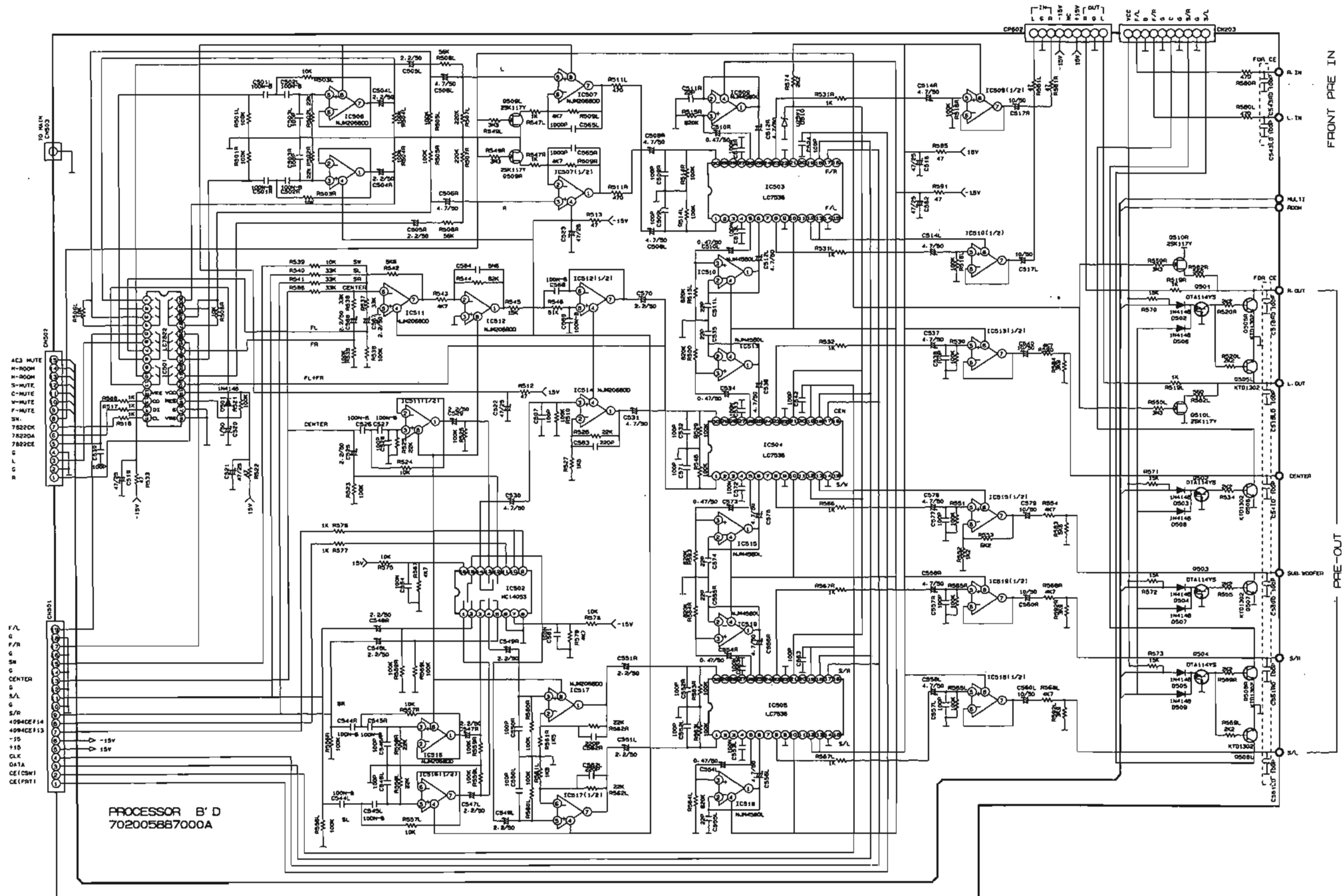

SCHEMATIC DIAGRAM (VIII)

Model No. : R-925R/R-925RDS

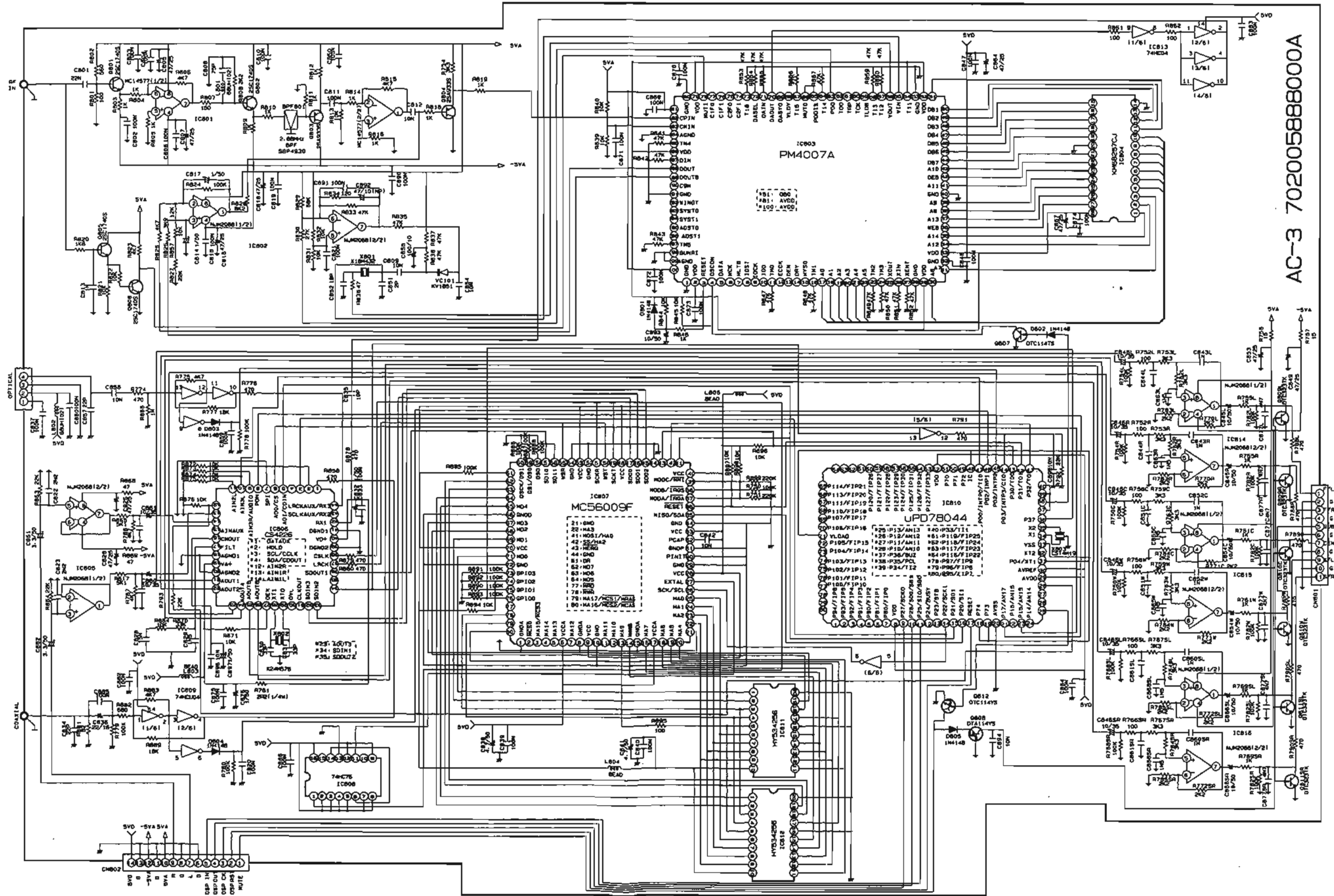

SCHEMATIC DIAGRAM (IX)

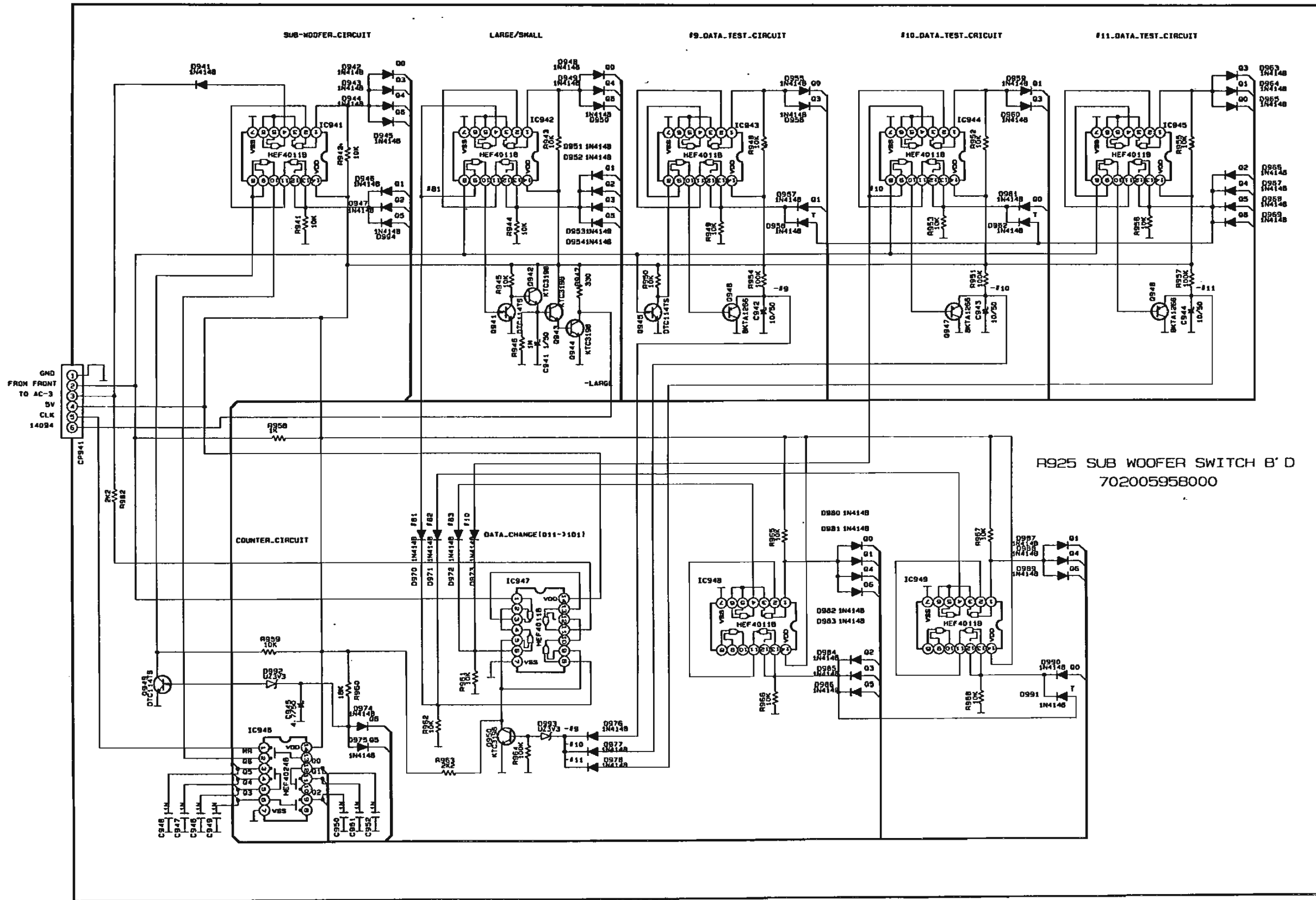

Model No. : R-925R/R-925RDS



AC-3 NEW PARTS for R-925

PART	ITEM	MAKER	REMARK	BLOCK	EXTERIOR
AMP	2SC5200		POWER TR		
	2SA1943		POWER TR		
	2SC1740S		BIAS TR		
	2SC4883				
	2SA1859				
MAIN	SBA60		DIODE		
	LTV817				
	KIA7815				
FRONT	CPU	SONY	SONY 100PIN		
AC-3	XCF56009FJ81	MOTOROLA	DSP		
	CS4226	CRYSTAL	A/D/A CONVERTER		
	PM4007A	PIONEER	DEMODULATER		
	KM68257CJ-15	SAMSUNG	SRAM		
	MC74HCU04ADR2	MOTOROLA	INVERTER,CHIP		
	MC74HC04AD	MOTOROLA	INVERTER,CHIP		
	SUB CPU	NEC	NEC 80PIN		
	BPF SBP-4930	TDK	2.88MHz		
	KV1851	TOKO	VARACTOR		
	MC74HC76N	MOTOROLA	J-K FF,CHIP		
	MC14577CP	MOTOROLA			
	NJM2068M	JRC	CHIP		
PROCESSOR	LC7536	SANYO	VOL IC		
	NJM4580L	JRC	OP-AMP		
	MC14053BD	MOTOROLA	SWITCHING,CHIP		
	LC7822	SANYO			
	NJM2068DD	JRC	OP-AMP		
INPUT	BA7625				
	MC14094				
	KIA4559				
	LC7821	SANYO			
	HY534256ALJ-60	HYUNDAI	DRAM(1M)		

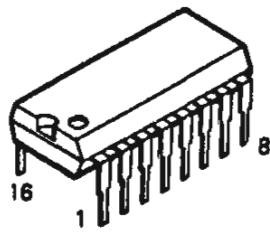
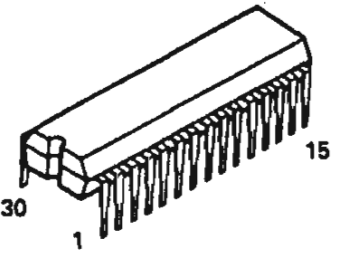
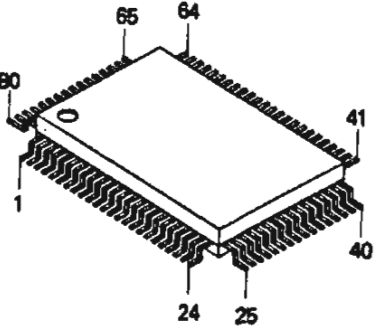
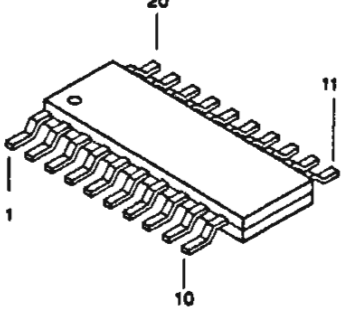
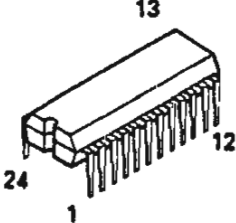
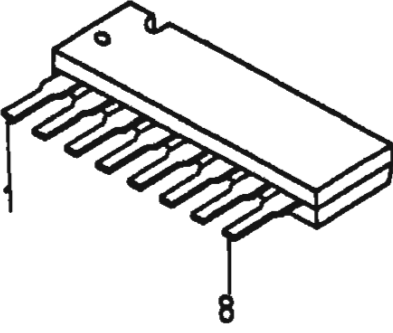
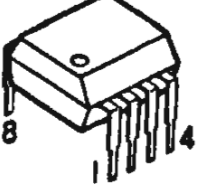
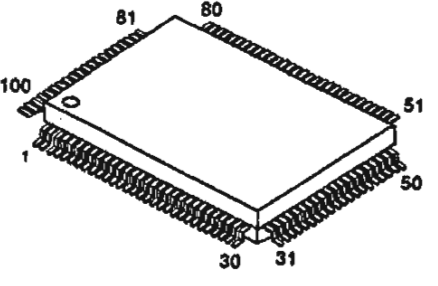
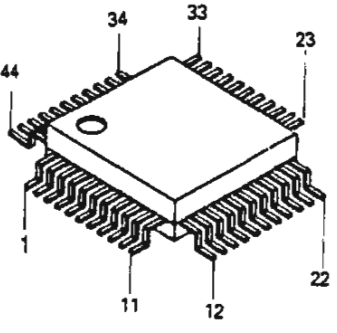
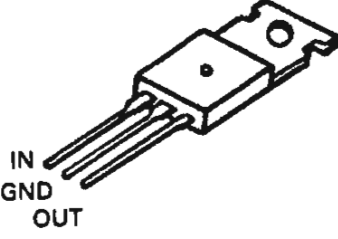
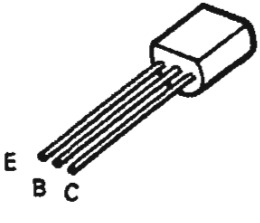
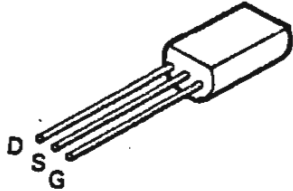
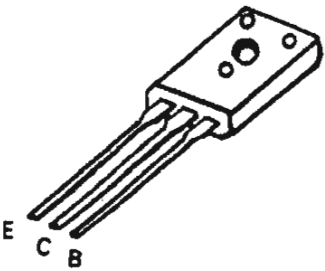
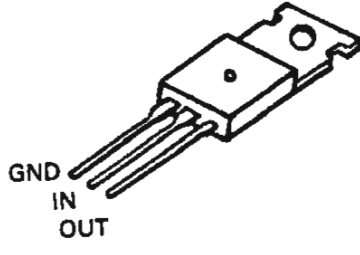
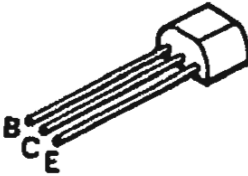
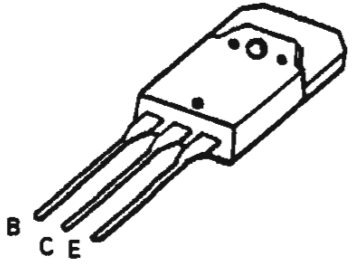
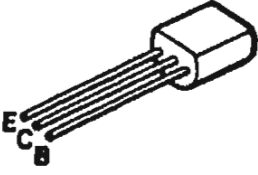
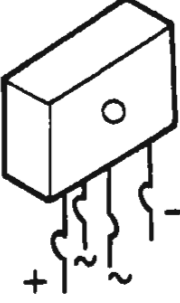
PIN CONNECTION DIAGRAM OF DIODES, TRANSISTORS AND ICS

<p>BA7625 74HC76 MC14053 MC14094</p> 	<p>LC7821 LC7822 LC7536</p> 	<p>CXP82852 UPD78044 MC56009F</p> 	<p>LM7001/M TDA7330BD</p> 
<p>LA3401 LA1266</p> 	<p>NJM2068</p> 	<p>KIA4559P/KIA7555P NJM4580L</p> 	<p>PM4007A</p> 
<p>CS4226</p> 	<p>KA7815 KA7806 KA7805</p> 	<p>MPSA06</p> 	<p>SK117</p> 
<p>2SA1360 2SC3423</p> 	<p>KA7915 KA7905</p> 	<p>DTA114YS DTC114YS</p> <p>KRA107N DTC323TS 2SC3199Y 2SC1740 KTA1267</p> 	<p>2SC3855/2SC3854 2SA1491/2SA1490</p> 
<p>KTC2240/KTC3200 KTC1923Y/KTC3194 KTA1268</p> 	<p>D5SBA60</p> 	<p>ZENER IN4003 IN4148</p> 	<p>SVC321SPA-C</p> 