

PREFACE:

The S7110B and S7125A are identical electrically and mechanically, differing only in panel model numbers and wood cases. The S7110B is used for illustration in this manual.

AMPLIFIER SERVICING AND ADJUSTMENT

NOTE:

For simplicity only the left channel and its related circuitry are described. The right channel is identical except for reference symbol numbers (see Schematic Diagram). For parts locations, refer to Figures 1A and 1B on the inside covers.

USE OF A VARIAC:

It is imperative that a variable voltage line source (Variac) equipped with a line watt-meter to identify abnormal power consumption be used when servicing power amplifiers and associated power supply circuitry. With the Volume (Loudness) control set at minimum, the power consumption should not exceed 20 watts as the voltage is increased by the Variac to the rated 120VAC. If the power consumption begins to exceed 20 watts, do NOT increase the line voltage any further. Determine if the malfunction is in the power supply, preamplifier, amplifiers, or tuner section of the receiver.

SPEAKER FUSE AND SPEAKER SYSTEM CHECK:

The S7110B and S7125A incorporate a speaker protection fuse in each channel. Verify that both fuses are unopened and that both speaker systems and their associated wiring are short-free.

LINE FUSE AND INITIAL CIRCUIT CHECKS:

Verify that the line fuse is unopened and check idling power consumption. The main causes for abnormal power consumption, in order of decreasing occurrence, are:

1. Open or shorted amplifier output, driver or pre-driver transistors TR602-609.
2. Open or shorted power supply diodes or filter transistor D801-804 and TR801.
3. Shorted power transformer.

NOTE:

For the following tests, an 8 ohm load resistor must be connected to each of the two power amplifier (speaker) output terminals.

## SUGGESTED AMPLIFIER TEST BENCH SET-UP

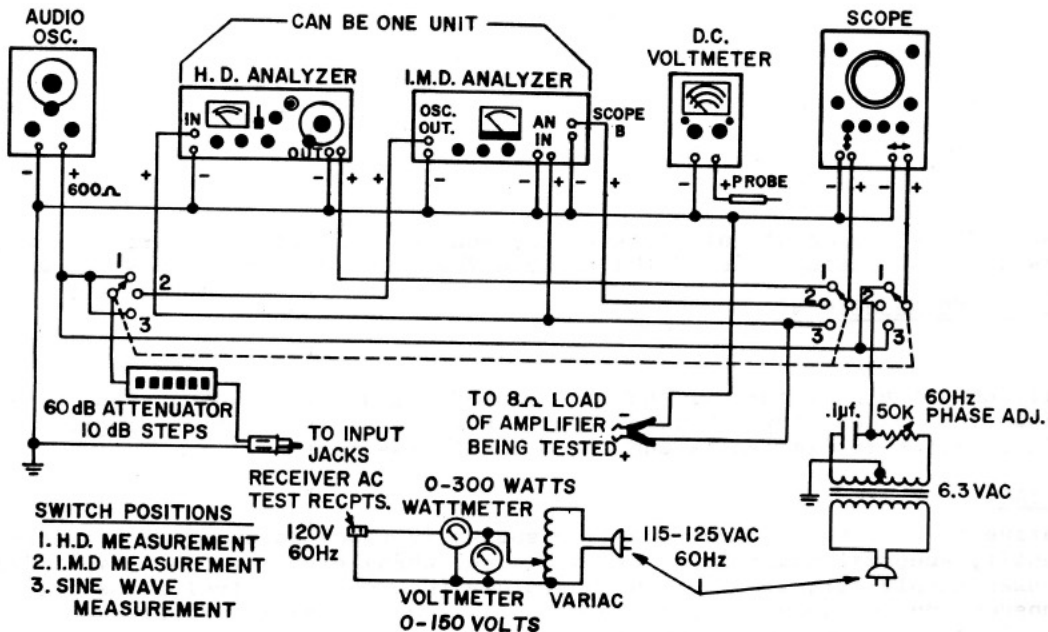

Figure 2

### AMPLIFIER FAULT ANALYSIS:

If an amplifier channel is in question, check related circuit boards for burned parts and replace. Check all the transistors with an ohmmeter\* for opens or shorts and replace if defective.

\*WARNING: Some ohmmeters may damage sensitive solid-state devices. Whenever possible, use a high resistance range (at least Rx10).

Use the centerpoint voltage (measured from the + speaker terminal to ground) as a guide. The centerpoint voltage should always be Zero  $\pm 50\text{mV}$ . Any deviation suggests shorted or open devices.

If channel operation is still faulty, verify that there are no shorted capacitors, open resistors, etc., on the board.

Inspect the underside of the board for shorted pads, broken connections, etc.

When the board is restored, readjust Output Bias (see below).

### DISTORTION IN THE AMPLIFIER OUTPUT:

Distortion which exceeds the amplifier ratings (see Front Cover) may be due to the following:

1. Mismatched output transistors.
2. Defective (low-beta) driver transistors.
3. Incorrectly adjusted output transistor bias.

### OUTPUT TRANSISTOR BIAS ADJUSTMENT:

Proper output transistor operation and output bias adjustment are most important to assure cool, low-distortion operation of the amplifier. Bias adjustment is necessary if the output transistors are replaced or if any of the transistors in the driver circuitry of the amplifier exhibits one or more of the following symptoms:

1. Overheating of the output transistors under normal operating conditions.
2. Excessive low level Intermodulation Distortion (IMD) or Total Harmonic Distortion (THD) - more than 0.3% at 3.0 volts across 8 ohms.

The following are three methods for adjusting output transistor bias:

BIAS ADJUSTMENT USING AN INTERMODULATION DISTORTION (IMD) ANALYZER:

1. Connect the receiver's amplifier for testing as in Figure 2.
2. Connect an Intermodulation Distortion Analyzer with a ratio of 4:1 using 60Hz and 7000Hz to the receiver's Left AUX input and set the SELECTOR switch to AUX.
3. Set the VOLUME (LOUDNESS) control to maximum and adjust the generator for an amplifier output of 3.0 volts across the 8 ohm load of the amplifier channel under test.
4. While observing the resultant distortion waveform, adjust the left channel bias pot VR601a so that the crossover distortion is at the point of being eliminated (class "AB"). NOTE: Class "A" operation (continued CW rotation) causes the output transistors to draw excessive current and consequently overheat. Refer to Figure 3 below.
5. Repeat Steps 3 to 4 for the Right channel.

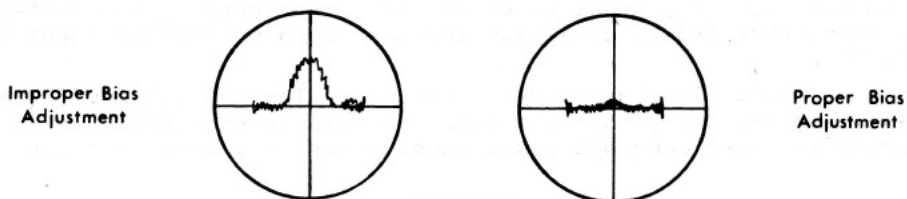

Figure 3

The following performance indicates a properly operating amplifier with both channels driven into 8 ohm loads:

1. Less than 0.3% Intermodulation Distortion (IMD) at 3.0 volts (typically 0.1%).
2. 20 watts of power per channel at no greater than 0.7% IMD.

BIAS ADJUSTMENT USING A HARMONIC DISTORTION ANALYZER:

1. Connect the receiver's amplifier for testing as in Figure 2.
2. Connect an oscillator with less than .05% distortion at 1000Hz to the receiver's Left AUX 1 input and set the SELECTOR switch to AUX.
3. Set the VOLUME (LOUDNESS) control to maximum and adjust the oscillator for an amplifier output of 3.0 volts across the 8 ohm load of the amplifier channel under test.
4. Using the Harmonic Distortion Analyzer, looking at the distortion of the amplifier properly nulled, make the adjustment as follows: Adjust the bias for class "AB" operation by turning the bias potentiometer VR601a so that the crossover is at the point of being eliminated. NOTE: Class "A" operation (continued CW rotation) causes the output transistors to draw excessive current and overheat. Refer to Figure 4 below.
5. Repeat Steps 3 and 4 for the Right channel.

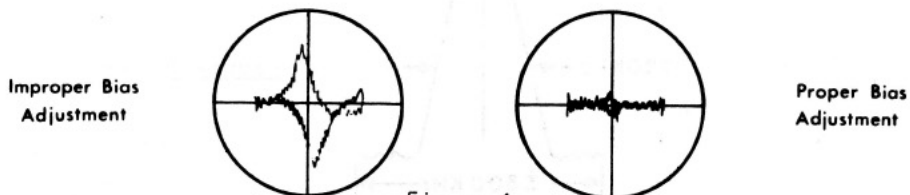

Figure 4

The following performance indicates a properly operating amplifier with both channels driven into 8 ohm loads:

1. Less than 0.1% THD at 3.0 volts (typically 0.05%).
2. 20 watts per channel at no greater than 0.7% THD (20-20,000Hz).
3. 22 watts per channel at no greater than 0.7% THD (1,000Hz).

#### BIAS ADJUSTMENT USING A LINE WATTMETER:

When test equipment required for previous bias adjustments is not readily available and adjustment is absolutely necessary, the following procedure may be used which requires only an accurate line wattmeter:

1. Turn the VOLUME (LOUDNESS) control to minimum.
2. Adjust the bias pots VR601a and VR601b one at a time to the point at which the amplifier begins to cause a very slight increase in line wattage consumption. Typical proper operation would develop a line wattage consumption of 22 watts.

#### POWER SUPPLY SERVICING AND FAULT ANALYSIS

Power supply malfunctions are usually due to shorted or open diodes D801-804, zener diode BZ-120, transistor TR801, or a high leakage, open or shorted input filter capacitor C805-806.

The devices may be easily checked with an ohmmeter. The transformer's operation may be checked by measuring secondary voltages with the associated circuit legs disconnected. Shorted windings can cause abnormal power consumption in a unit that otherwise functions well.

#### FM TUNER AND IF ALIGNMENT (Refer to Figures 1A and 1B for parts locations)

1. Set the SELECTOR switch to FM. Connect an FM generator to the 300 ohm antenna terminals using a matching transformer with a 1:1 voltage ratio or, if necessary, use a 2:1 ratio resistive network as shown below in Figure 5.

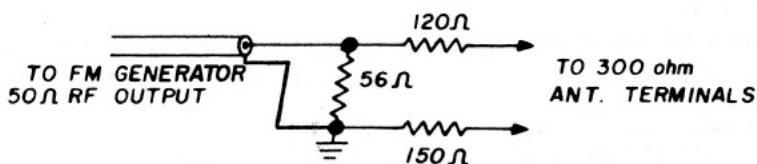

Figure 5

2. Tune the receiver to a point of no signal or interference near 90MHz.
3. Tune the FM generator, modulated  $\pm 300\text{KHz}$  at approximately 20uV output level, to the receiver frequency. Connect an RF detector probe to pin 5 of the AN217 (IC202) and center the FM IF response on the oscilloscope. The FM IF bandpass characteristics are now being displayed. Adjust the transformer core of the RF converter T101 for maximum gain and symmetry (Figure 6).

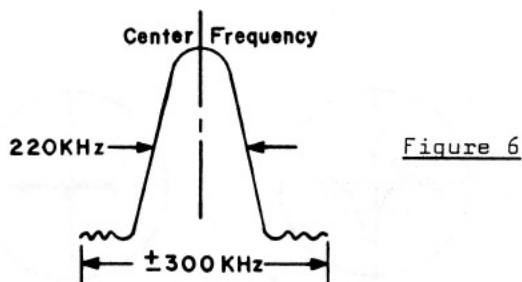

Figure 6

4. The FM front end alignment can also be determined while observing the oscilloscope display of Step 3. Tune the receiver and generator to a point of no interfering signal near 90MHz. Check that the receiver dial pointer indicates within  $\pm 100\text{KHz}$  from the generator frequency. (If the generator output frequency is not accurately calibrated, a FM station can be used as a calibration reference.) If the dial

deviation exceeds 100KHz, adjust the local oscillator coil L103 slightly, until optimum dial calibration is obtained. Next, adjust the RF amplifier coils L101 and L102 for maximum gain. Tune the receiver and the generator to a point of no interference near 106MHz. Check the dial calibration. If required, adjust the local oscillator trimmer TC103 until optimum dial calibration is obtained. Now, adjust the RF amplifier trimmers TC101 and 102 for maximum gain. Repeat alignment at 90MHz and 106MHz until no further improvement is realized.

#### 5. DETECTOR ALIGNMENT USING AN OSCILLOSCOPE:

To align the FM detector, leave the FM generator connected as in Step 1, and move the oscilloscope lead to the REC output jack on the rear panel. Reduce the modulation to  $\pm 75$ KHz. Adjust the top core of the detector transformer T201 for a 0 VDC reading on the voltmeter connected across R224. The bottom core of the transformer T201 is adjusted for best gain and linearity as observed on the oscilloscope (see Figure 7). Recheck the voltmeter 0 voltage reading and readjust the top core again if necessary.

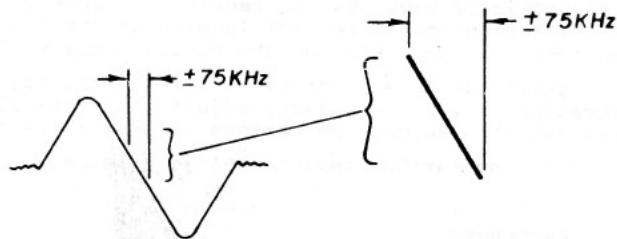

Figure 7

#### 6. DETECTOR ALIGNMENT USING A HARMONIC DISTORTION ANALYZER:

A distortion analyzer should be used in conjunction with an oscilloscope to obtain the best linearity, using 400Hz at  $\pm 75$ KHz modulation. Fine adjust the bottom core of the detector transformer T201 for the lowest distortion (slight adjustment only).

#### 7. STEREO THRESHOLD ADJUSTMENT:

This receiver incorporates a stereo threshold circuit which automatically switches from mono to stereo FM mode, if the station to which the receiver is tuned is transmitting a stereo program and if the station's signal strength (signal to noise ratio) is considered acceptable for stereo listening. Should the noise increase, the receiver will automatically switch to the mono mode.

To adjust the stereo threshold switching level, connect a FM stereo generator and an oscilloscope as used for multiplex alignment. With the receiver front panel STEREO/MONO switch in the STEREO mode, slowly increase the generator output from zero to the automatic threshold level. Prior to the automatic switching point, the receiver will have equal (mono) Left and Right channel outputs. After the receiver's stereo threshold level is reached, the multiplex generator's Left channel modulation will appear only on the receiver's Left channel output.

The receiver's desired stereo signal threshold level can be set by adjusting VR201. The recommended threshold level is 5 microvolts.

#### PHASE-LOCK LOOP MULTIPLEX ADJUSTMENT

This receiver utilizes an integrated circuit phase-lock loop (PLL) stereo demodulator. The phase-lock loop is essentially a free-running 76KHz oscillator (subsequently divided down to 38KHz and 19KHz) which locks onto the stereo pilot tone of the transmitted signal, enabling accurate signal decoding. Proper adjustment of the free-running oscillator [voltage controlled oscillator (VCO)] frequency control VR301 is essential for stability and proper channel separation.

#### PLL ADJUSTMENT USING A DIGITAL FREQUENCY COUNTER AND AN FM STEREO GENERATOR:

Tune the receiver to a point of no signal or interference.

Tune the generator to the receiver frequency and set it for an unmodulated stereo signal at 100 microvolt output. With the frequency counter probe attached to Pin 12 (test pin provided) of IC301, adjust VR301 for 19KHz  $\pm$ 10Hz. Using a stereo test signal (left or right channel), adjust VR302 for best total separation and minimize differences in the left-to-right and right-to-left separation. The separation should be 40dB minimum in reference to 100% modulated audio at 1000Hz.

If 40dB is not obtainable, apply pilot signal only and check the left and right multiplex outputs for 19KHz/38KHz residual. It should be a minimum of -50dB below audio reference.

#### PLL ADJUSTMENT USING ONLY AN FM STEREO GENERATOR (FREQUENCY COUNTER NOT AVAILABLE):

With the receiver tuned to a stereo signal, adjust VR301 to determine the endpoints for stereo lock-in and set the control halfway between these end-points. Using a stereo test signal, adjust VR302 for best separation.

#### AM TUNER AND IF ALIGNMENT

1. Set the receiver's Selector switch to AM. Tune the receiver to a point of no signal or interference near 600KHz. Connect the oscilloscope/VTVM to the REC Output jack. Connect the AM generator output to the receiver's AM Antenna terminal through a 200pF capacitor.
2. Adjust the AM generator to 455KHz RF output, modulated 400Hz, at 50%. Tune the AM converter/AM IF T401 cores and the 2nd AM IF T402 core for maximum audio output.
3. Adjust the AM generator for 600KHz. If required, adjust the AM oscillator L401 so that the generator signal is received by the receiver at 600KHz, as indicated on the dial scale. Adjust the Rod Antenna core L451 located at the end of the antenna rod assembly for maximum output as indicated on the oscilloscope/VTVM.
4. Tune the receiver and generator to a point of no interfering signal near 1400KHz. Check the dial calibration and, if necessary, adjust the AM oscillator trimmer TC105 for optimum dial calibration. Adjust the antenna trimmer TC104 for maximum output.
5. Repeat Steps 3 and 4 until no further improvement is obtained.

#### MECHANICAL DETAILS

##### PUSH-BUTTON SWITCH REPAIR PROCEDURE:

Each push-button switch may be disassembled individually. To repair a defective section of the switch, proceed as follows (refer to Figure 8):

1. Remove the push-button knob by pulling it away from the shaft.
2. Hold your finger on the push-button shaft so that the shaft can not push outward and by using a long nose pliers, move the shaft spring (E) away from the switch body until the locking pin (H) can be removed.
3. Remove the locking pin and slowly release the push-button shaft. Remove the shaft assembly from the switch body.
4. Locate the malfunction and repair the defective part by referring to the push-button detail (Figure 8) for disassembly and reassembly of the various switch parts.
5. To reassemble the switch, insert the complete push-button shaft assembly into the switch body, holding it in to about the normal out position.
6. Carefully grasp the locking pin at its front edge with a long nose pliers and slowly compress the shaft spring until the locking pin can be inserted in the switch body.
7. Release the shaft spring, being careful that correct reassembly has been achieved.
8. Replacing the push-button knob completes reassembly.

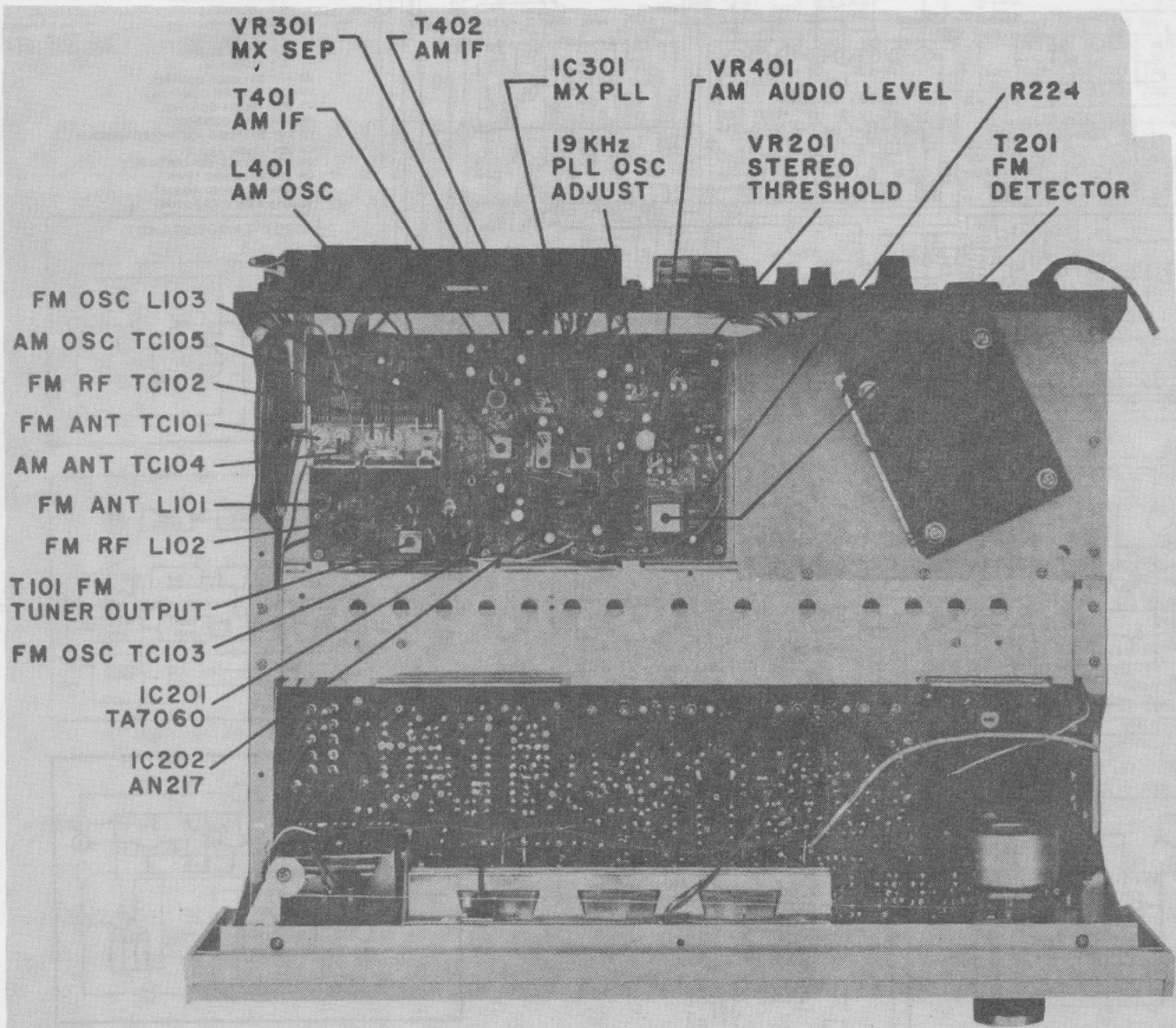

(TOP VIEW)  
FIGURE 1A

VR301	MX SEP	VR401	AM AUDIO LEVEL
T401	AM IF	T201	FM DETECTOR
L401	AM OSC	IC301	MX PLL
FM OSC	LI03	19 KHz	PLL OSC ADJUST
AM OSC	TC105	VR201	STEREO THRESHOLD
FM RF	TC102	R224	
FM ANT	TC101	T101	FM TUNER OUTPUT
AM ANT	TC104	FM OSC	TC103
FM ANT	LI01	IC201	TA7060
FM RF	LI02	IC202	AN217

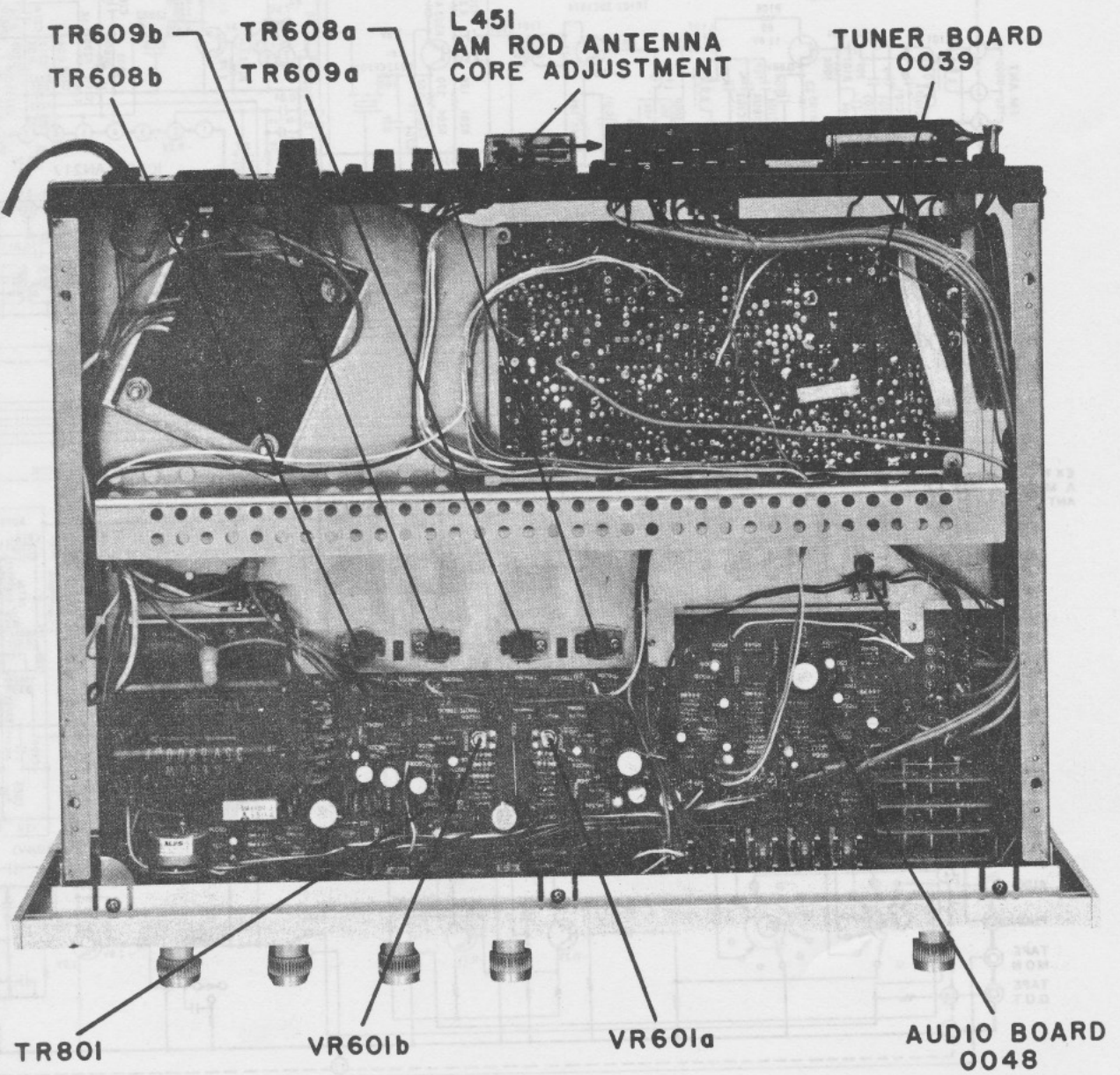

(BOTTOM VIEW)  
FIGURE 1B



SCHEMATIC DIAGRAM

#0039 TUNER BOARD

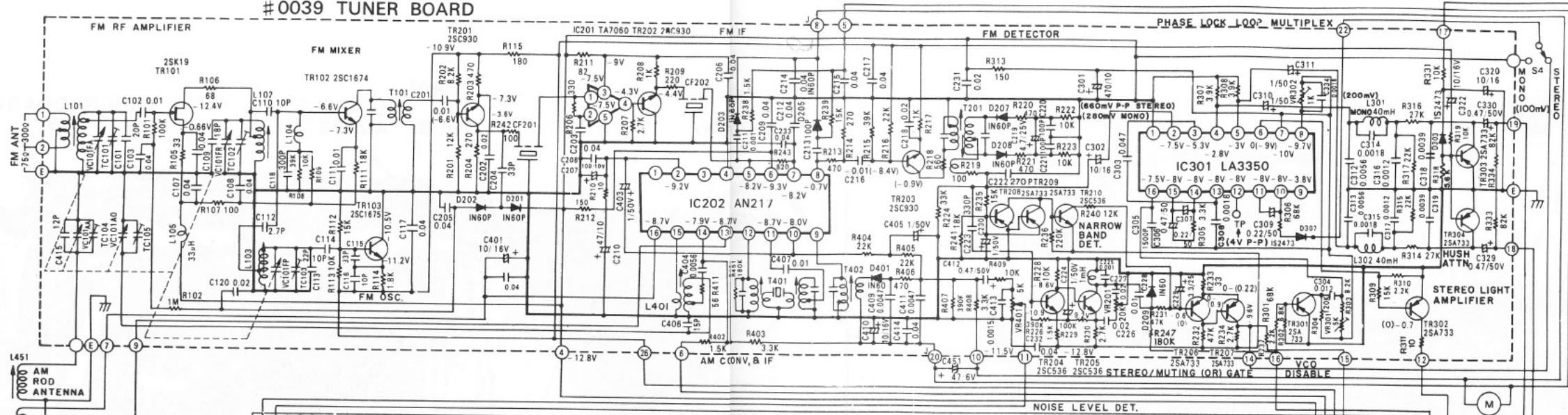

- S 1: SELECTOR
- 1: PHONO
- 2: FM MUTE
- 3: FM
- 4: AM
- 5: AUX
- S 2: TAPE MONITOR
- S 3: LOUDNESS
- S 4: MODE
- S 5: SPEAKER (A)
- S 6: SPEAKER (B)
- S 7: POWER
- VR 601: BALANCE CONTROL
- VR 602: VOLUME CONTROL
- VR 603: TREBLE CONTROL
- VR 604: BASS CONTROL
- VR 201: STEREO & MUTING THRESHOLD
- VR 301: 19kHz ADJUST
- VR 302: STEREO SEPARATION
- VR 401: AM AUDIO LEVEL
- VR601a: L CH BIAS ADJUST
- VR601b: R CH BIAS ADJUST

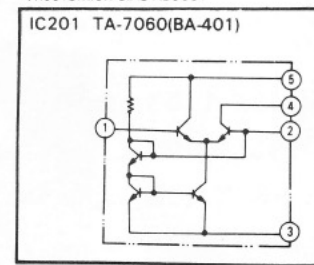

#0048 AUDIO BOARD

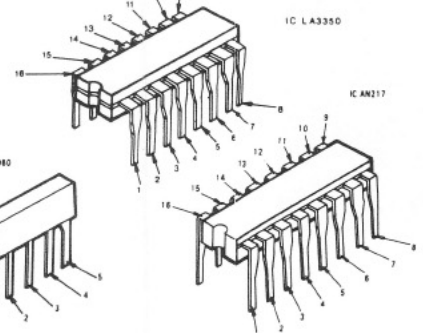
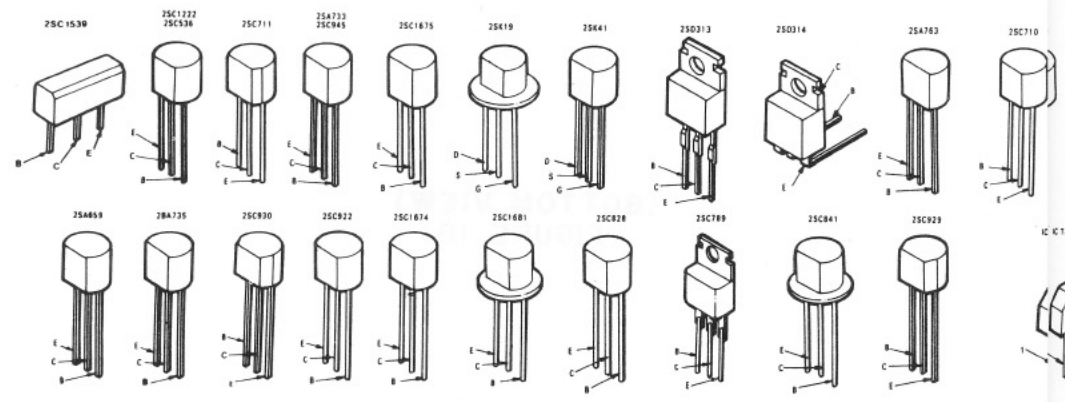
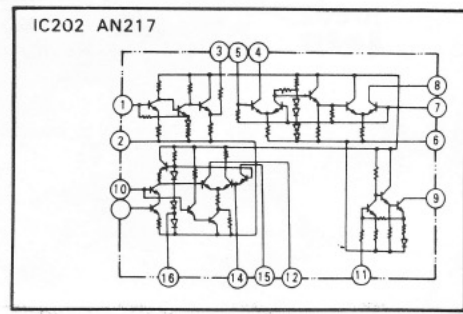
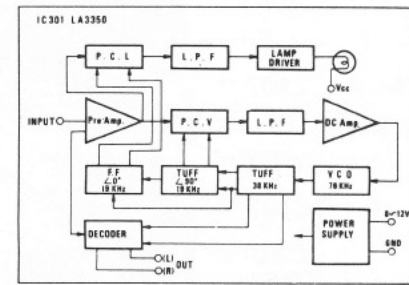
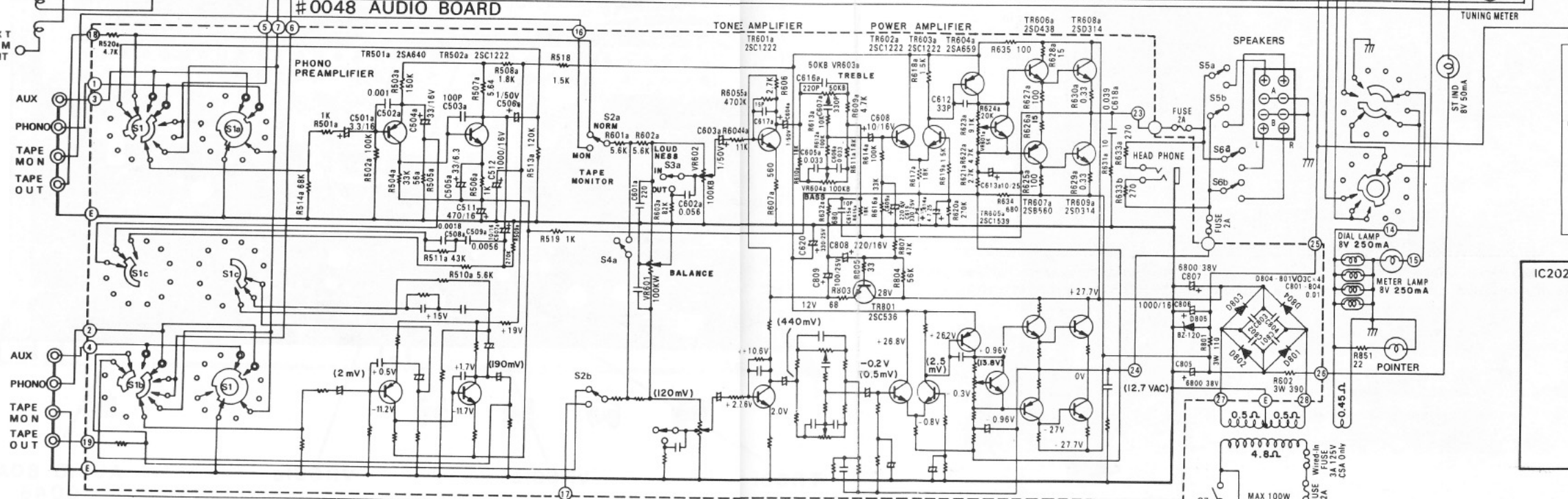

Note: 1. Resistance values are indicated in ohms unless otherwise specified (K=1,000, M=100,000).  
 2. Capacitance values are shown in microfarads unless otherwise noted (P=micro microfarads).  
 3. DC and AC voltages are referenced to ground under the following conditions.  
 DC: No signal (120 VAC line)  
 AC: Audio Amplifier -1 KHz, for rated output with an 8-ohm load and volume at maximum.  
 4. Component values are subject to change without notice.

SUBSTITUTE TRANSISTOR	
TR101	2SK41
TR102	2SC922, 2SC1047
TR201, 202	2SC710, 2SC380, 2SC929
TR204, 205	2SC1364, 2SC711, 2SC828, 2SC945
TR206, 207, 208	2SA678, 2SA735
TR501	2SA763, 2SA726, 2SA841
TR502, 601	2SC1313, 2SC1681
602, 603	
IC201	BA401
TR604	2SA735, 2SA678
TR605	2SC1542, 2SC1537
TR606	2SC1509
R607	2SA777
TR608, 609	2SD313, 2SC789
TR801	2SC945, 2SC711A

#0039 TUNER BOARD

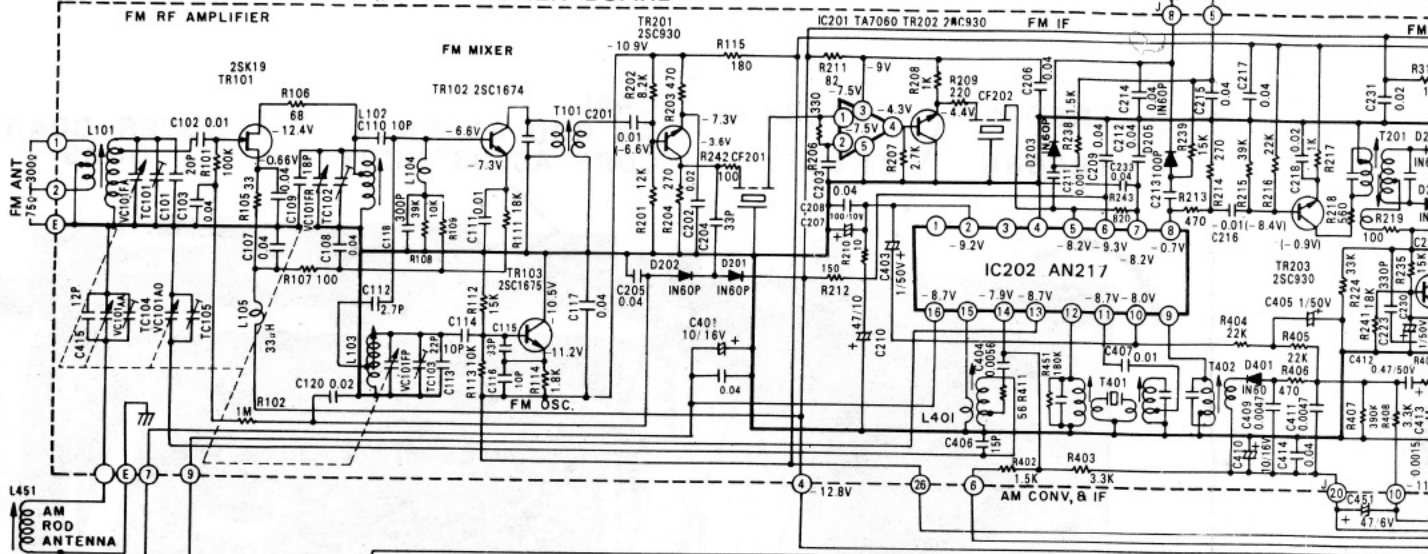

# SCHEMATIC DIAGRAM

# SHERWOOD S-7110B AM/FM STEREO RECEIVER

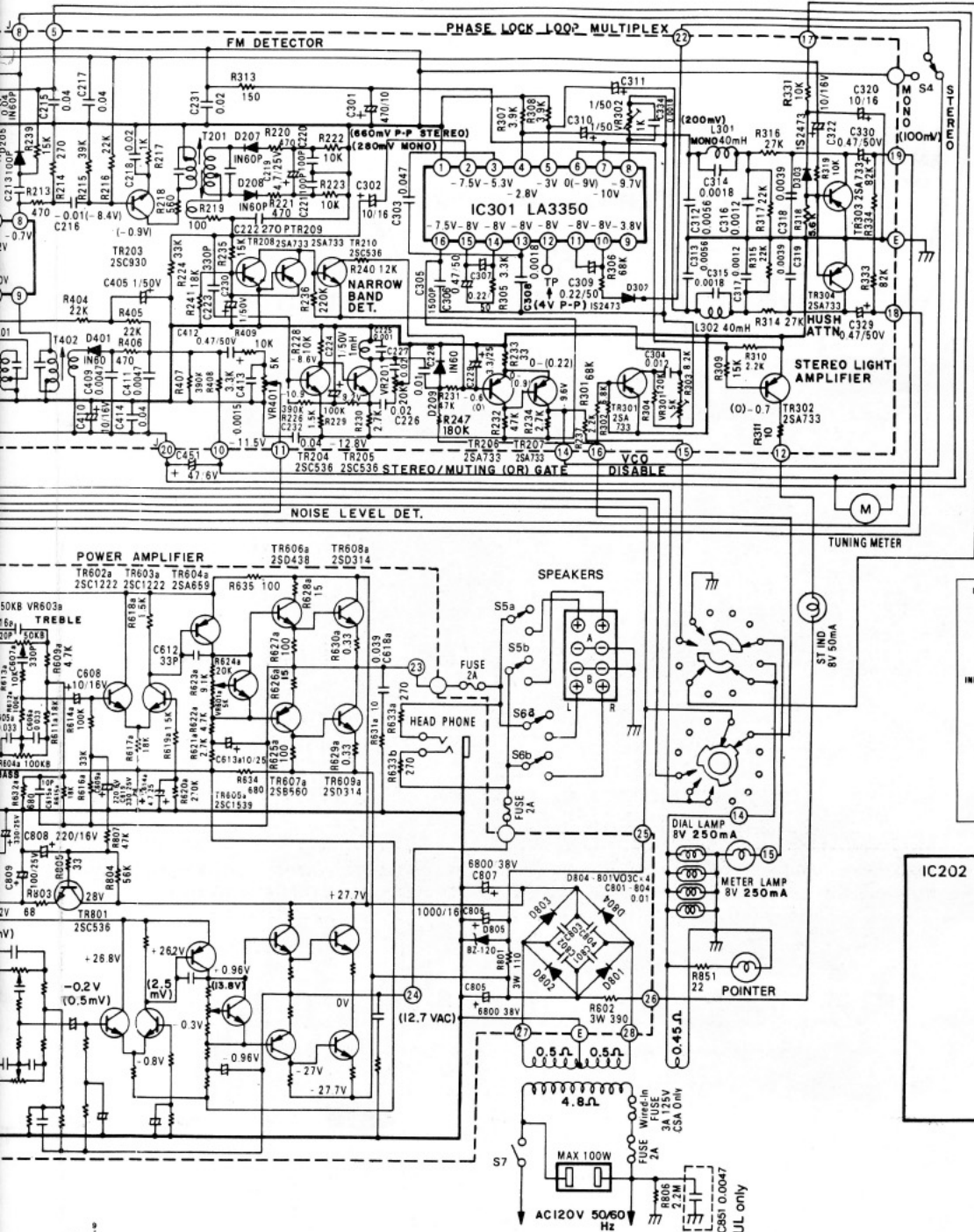

- S1: SELECTOR
- 1: PHONO
- 2: FM MUTE
- 3: FM
- 4: AM
- 5: AUX
- S2: TAPE MONITOR
- 6:3: LOUDNESS
- 5:4: MODE
- 5:5: SPEAKER (A)
- 5:6: SPEAKER (B)
- S7: POWER
- VR 601: BALANCE CONTROL
- VR 602: VOLUME CONTROL
- VR 603: TREBLE CONTROL
- VR 604: BASS CONTROL
- VR 201: STEREO & MUTING THRESHOLD
- VR 301: 19KHz. ADJUST
- VR 302: STEREO SEPARATION
- VR 401: AM AUDIO LEVEL
- VR601a: L CH BIAS ADJUST
- VR601b: R CH BIAS ADJUST

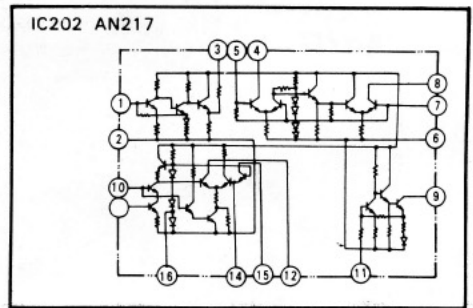
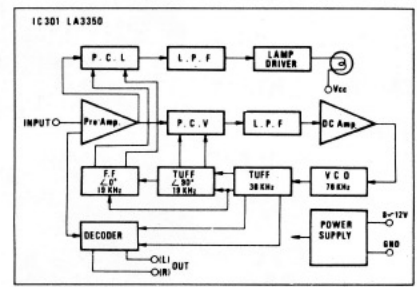
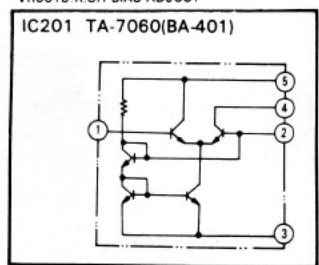

SUBSTITUTE TRANSISTOR	
TR101	2SK41
TR102	2SC922,2SC1047
TR201, 202 203, 103	2SC710,2SC380,2SC929
TR204, 205	2SC1364,2SC711,2SC828,2SC945
TR206, 207, 208 209,301,302,304	2SA678,2SA735
TR501	2SA763,2SA726,2SA841
TR502,601 602,603	2SC1313,2SC1681
IC201	BA401
TR604	2SA735,2SA678
TR605	2SC1542,2SC1537
TR606	2SC1509
R607	2SA777
TR608, 609	2SD313,2SC789
TR801	2SC945,2SC711A

Note: 1. Resistance values are indicated in ohms unless otherwise specified (K=1,000, M=100,000).  
 2. Capacitance values are shown in microfarads unless otherwise noted (P=micro microfarads).  
 3. DC and AC voltages are referenced to ground under the following conditions.  
 DC: No signal (120 VAC line)  
 AC: Audio Amplifier - 1KHz, for rated output with an 8-ohm load and volume at maximum.  
 4. Component values are subject to change without notice.

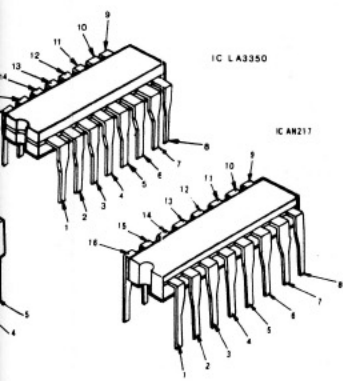

# SHERWOOD S7110B and S7125A REPLACEMENT PARTS LIST

**Sherwood S7110B, S7125A**

ALL PRICES ARE SUBJECT TO CHANGE WITHOUT NOTICE

<u>TRANSISTORS &amp; FETS</u>	REFERENCE NO.	PART NO.	LIST PRICE	ELECTROLYTICS (Cont.)	REFERENCE NO.	PART NO.	LIST PRICE
2SA659	TR604a,b	30000211	\$1.44	10 @ 16V	C302, 320, 322, 401, 410, 507a,b;	64042106	\$ .63
2SA640	TR501a,b	30000241	1.13		608a,b		
2SA733	TR206, 207, 208, 209, 301, 302, 304	30000424	1.07	10 @ 25V	C613a,b	64043106	.63
2SB560	TR607a,b	30100041	1.58	33 @ 6.3V	C505a,b	64040336	.60
2SC536	TR204, 205, 210, 801	30200131	1.00	33 @ 16V	C504a,b	64042336	.63
2SC930	TR201, 202, 203	30200271	1.07	47 @ 6.3V	C210	64040476	.75
2SC1222	TR502a,b; 601a,b; 602a,b; 603a,b	30200662	1.07	100 @ 10V	C207	64041107	.75
2SC1539	TR605a,b	30200921	1.18	100 @ 25V	C809	64043107	1.11
2SC1674	TR102	30201111	1.13	220 @ 6.3V	C609a,b	64040227	.86
2SC1675	TR103	30201121	1.00	220 @ 16V	C808	64012227	.96
2SD314 [Output]	TR608a,b; 609a,b	30300220	2.22	330 @ 25V	C620	64043337	1.40
2SD438	TR606a,b	30300250	1.50	330 @ 25V [Axial]	C619	64143337	1.53
2SK19 [FET]	TR101	30400021	2.05	470 @ 16V	C301, 511	64042477	1.40
				1000 @ 16V	C512, -806	64042108	1.53
				6800 @ 35V	C805, 807	64134688	5.94

INTEGRATED CIRCUITS

LA3350	IC301	30900310	5.97
AN217	IC202	30900170	4.86
TA7060P	IC201	30900300	1.70

DIODES: SIGNAL, POWER & ZENER

1N60	D209, 401	30600010	.60
1N60P	D201, 202, 203, 205, 207, 208	30600011	.60
1S2473	D302, 303	30600410	.60
BZ-120 [12VZ, 5%, 1W]	D805	30600440	1.61
V03C [1.3A, 200 PIV]	D801, 802, 803, 804	30600040	1.18

ELECTROLYTIC CAPACITORS [PC unless otherwise specified]

0.22 @ 50V [Non-Polar]	C307, 309	64535224	1.00
0.47 @ 50V	C306, 329, 330	64045474	.60
1 @ 50V	C224, 230, 310, 311, 403, 405, 506a,b; 603a,b	64045105	.60
1 @ 50V [Axial]	C604a,b	64145105	1.16
3.3 @ 16V [Tantalum]	C501a,b	66063335	1.13
3.3 @ 25V	C229	64043335	.61
4.7 @ 25V	C219, 304, 614a,b	64043475	.63

COILS & TRANSFORMERS

COIL, FM ANTENNA	L101	#120A	2.05
COIL, FM RF	L102	#120B	1.24
COIL, FM OSCILLATOR	L103	#116L	1.24
COIL, RF CHOKE	L104		.59
COIL, RF CHOKE	L105	33uH	.59
COIL, RF CHOKE	L201	#102K	.73
COIL, CHOKE 40mH	L301, 302		1.32
COIL, AM OSCILLATOR	L401	#413L	1.24
COIL, AM ROD ANTENNA	L451		4.68
TRANSFORMER, TUNER OUT	T101	#204E	1.40
TRANSFORMER, FM DET	T201	#214D	1.40
TRANSFORMER, MPX	T301	#314A	1.93
TRANSFORMER, CERAMIC	T401	CFT-455B	4.44
TRANSFORMER, AM IF	T402	#401D	2.28
TRANSFORMER, POWER T1			1.32
TRANSFORMER, POWER [EXPORT] T1			36.09
			45.00

GENERAL ELECTRICAL COMPONENTS

CERAMIC FILTER* [SFE10.7MA]	CF201, 202	35300012*	1.56
FUSE, 2 AMP, 250V	Spkrs & Line	312002	.23
METER, TUNING, PEAK M1		60200010	10.71
PILOT LAMP, 8V/0.25A	PL1, 2, 3, 4	37008019	1.32

\*Specify color of dot on filter being replaced.

[over]