



AMS8100 Automatic Microphone Mixer

Service Manual

Schematics:

Master Section	Printed Circuit Board Legend - Enlarged View
Master Section - Enlarged View 1 Audio and Control	Individual Channel Schematic
Master Section - Enlarged View 2 Output Meter	Individual Channel Schematic- Enlarged View 1 Audio
Master Section - Enlarged View 3 Power Supply	Individual Channel Schematic- Enlarged View 2
Master Section - Enlarged View 4 Logic Control In/Out	Directional Intellimix
Printed Circuit Board Legend Logic Control In/Out	Individual Channel Schematic- Enlarged View 3 Logic

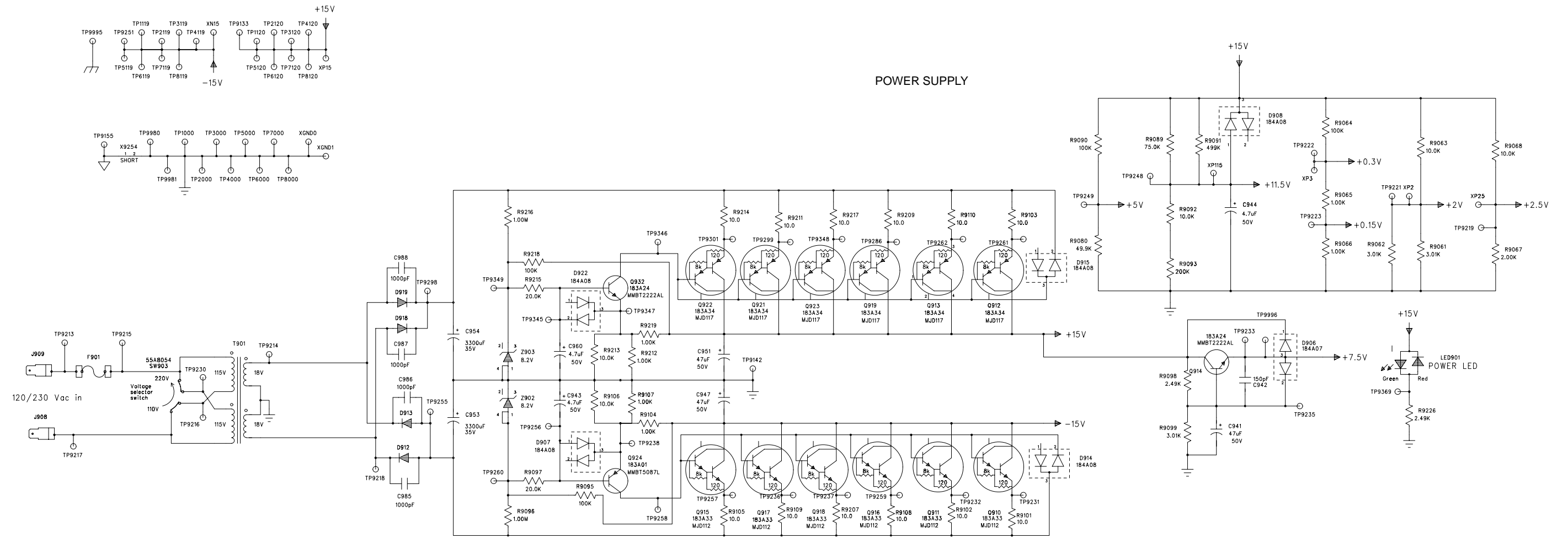

Shure AMS8100 Automatic Microphone Mixer
Master Section
Enlarged View, Page 3

Shure AMS8100 Automatic Microphone Mixer

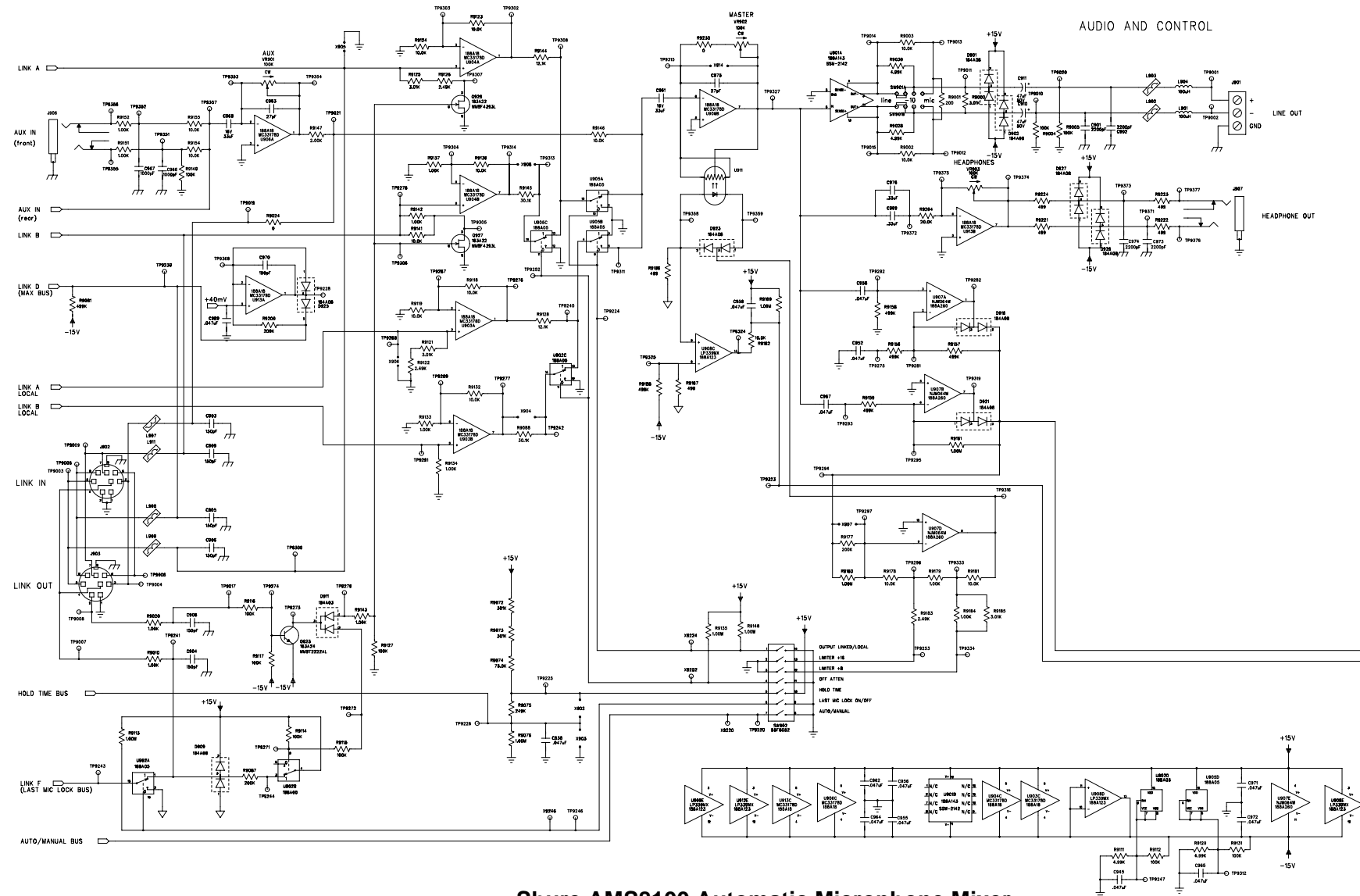

Shure AMS8100 Automatic Microphone Mixer
Master Section

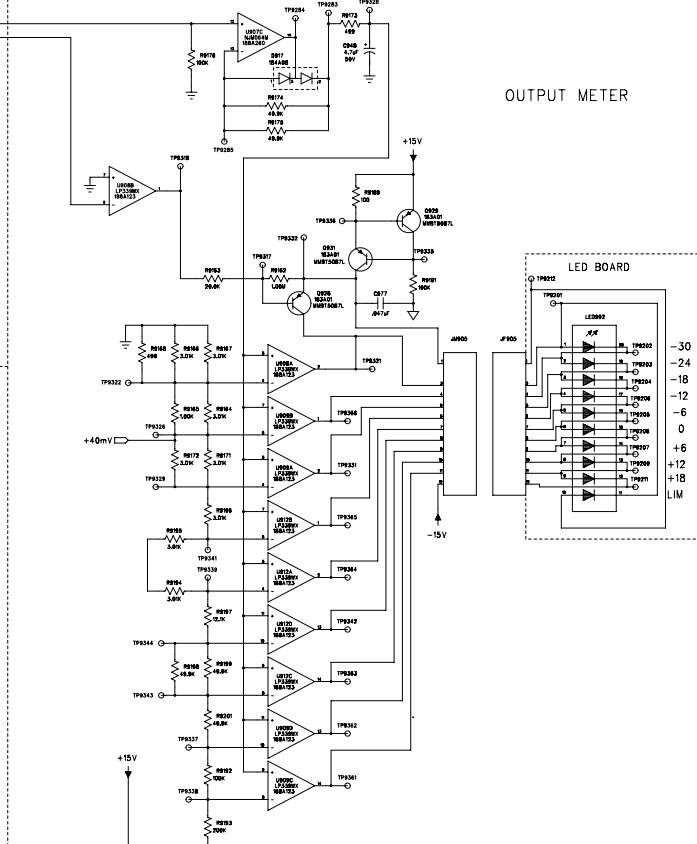
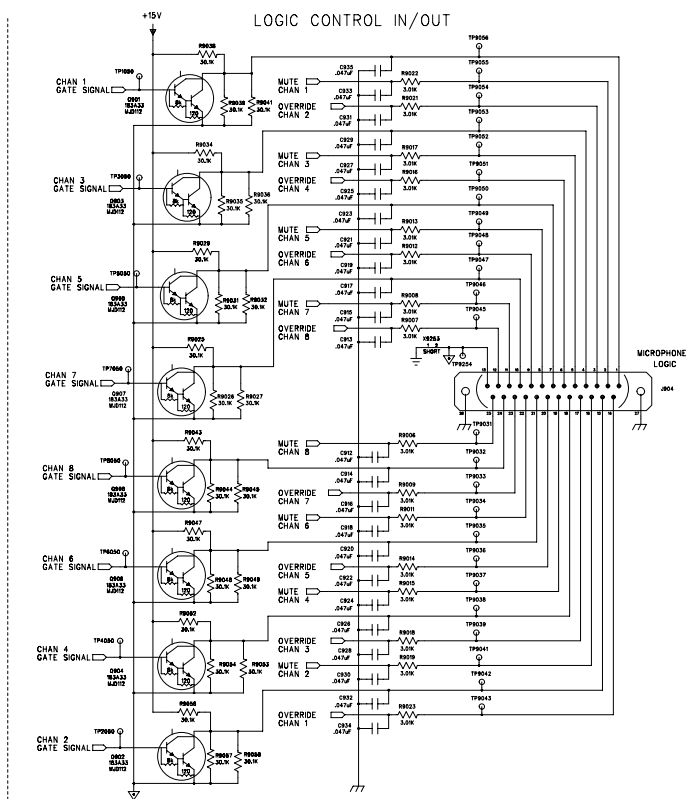

Printed in U.S.A.

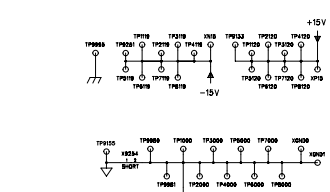

- NOTES:
- All resistors 1/10 Watt, 1%, 0805 unless otherwise specified.
 - Electrolytic capacitors shown in μ F, Tolerance 10% and 50V or more unless otherwise specified.
 - The following symbols denote:
 - A.C. Voltage
 - P.C. ground
 - D.C. Voltage
 - Chassis ground

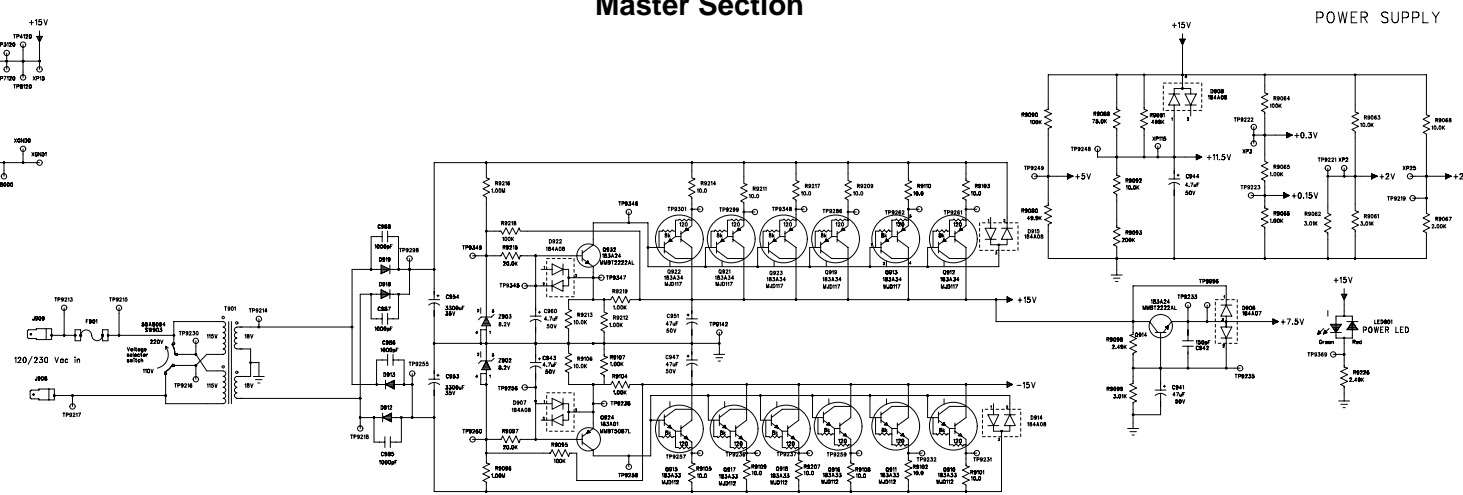

©1998, Shure Brothers Inc.
25A1041 (RA)

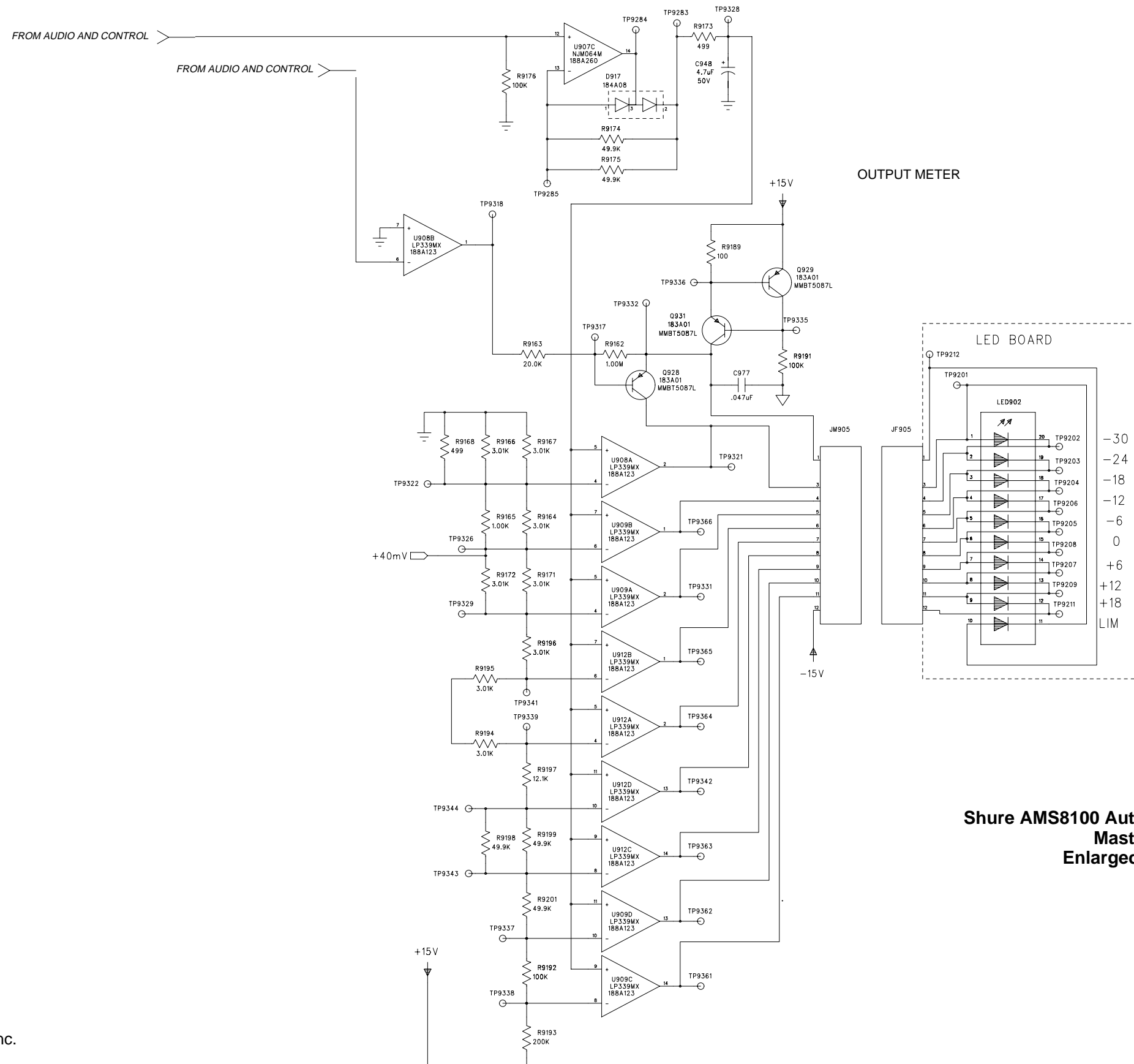

Shure AMS8100 Automatic Microphone Mixer
Master Section
Enlarged View, Page 2

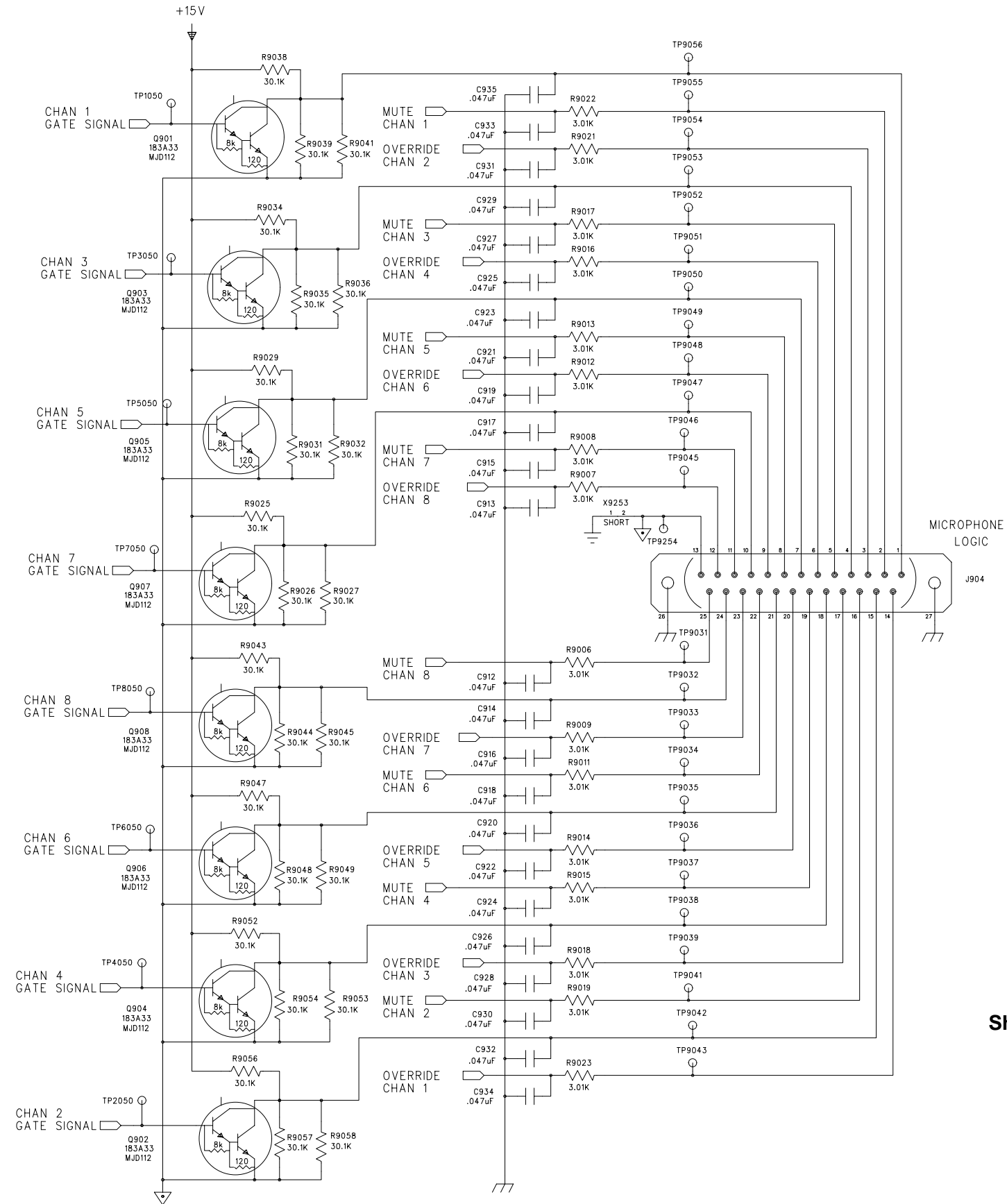

LOGIC CONTROL IN / OUT

Shure AMS8100 Automatic Microphone Mixer
Master Section
Enlarged View, Page 4

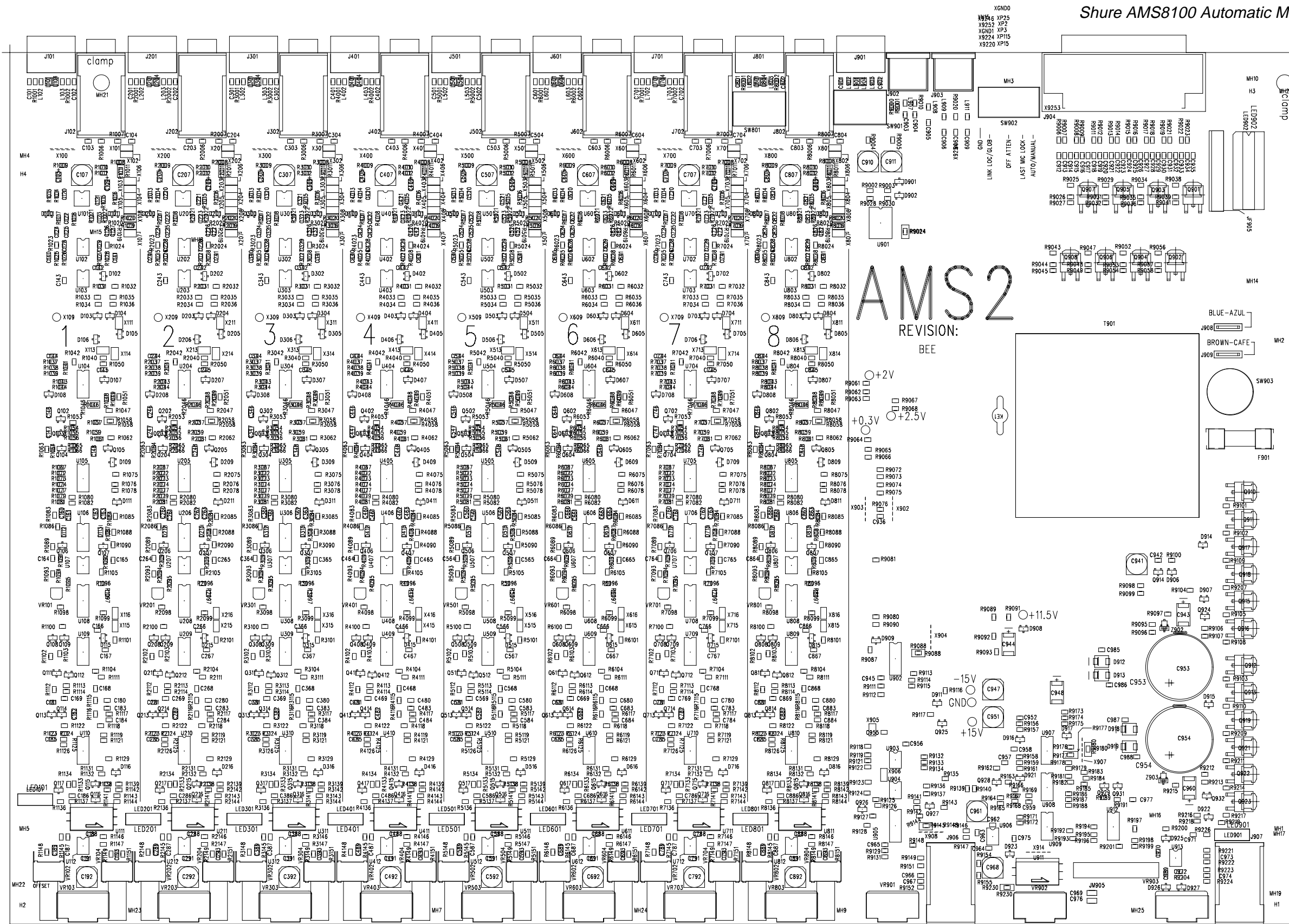

Shure AMS8100 Automatic Microphone Mixer

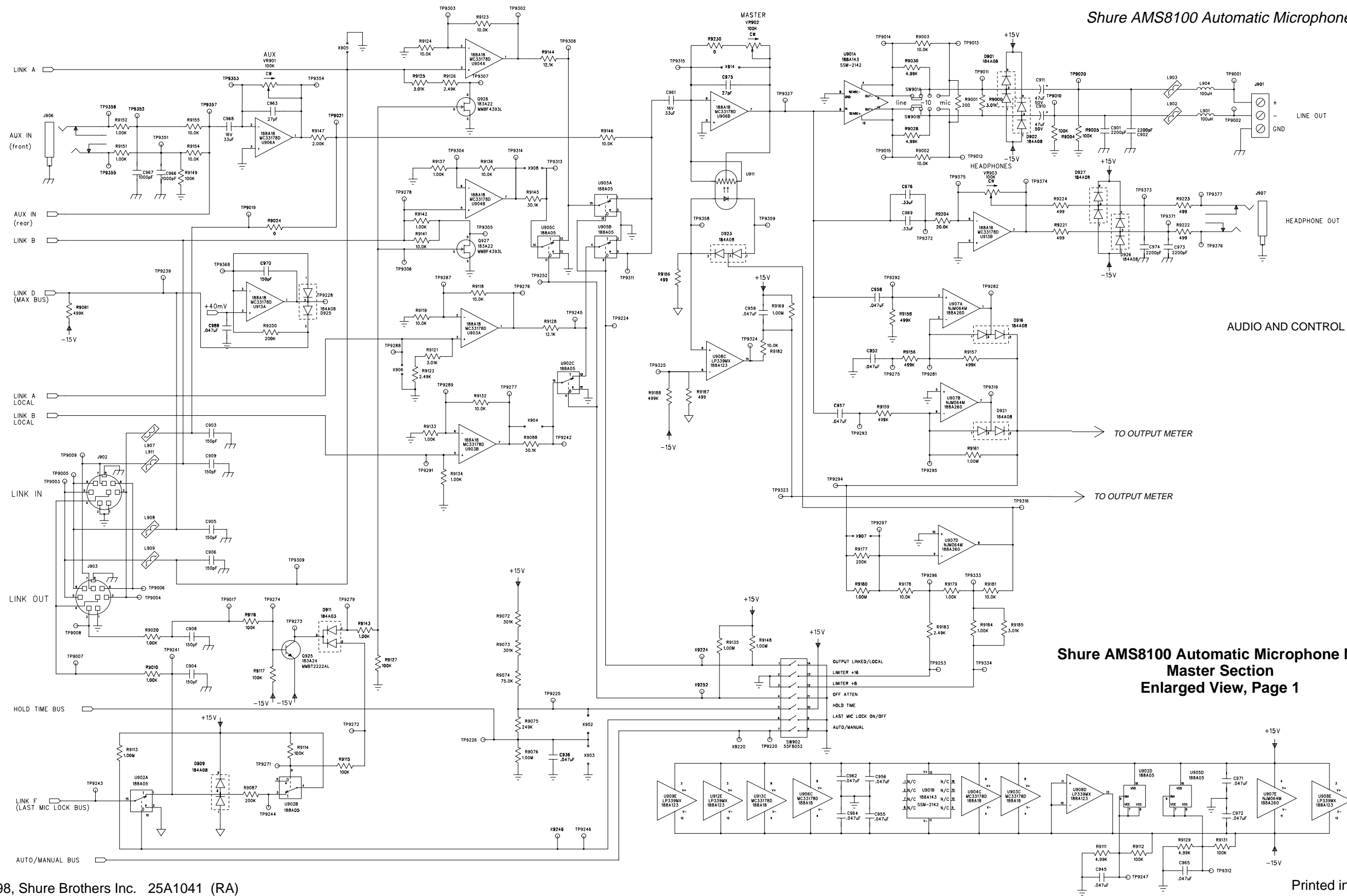

Shure AMS8100 Automatic Microphone Mixer
Master Section
Enlarged View, Page 1

Shure AMS8100 Automatic Microphone Mixer

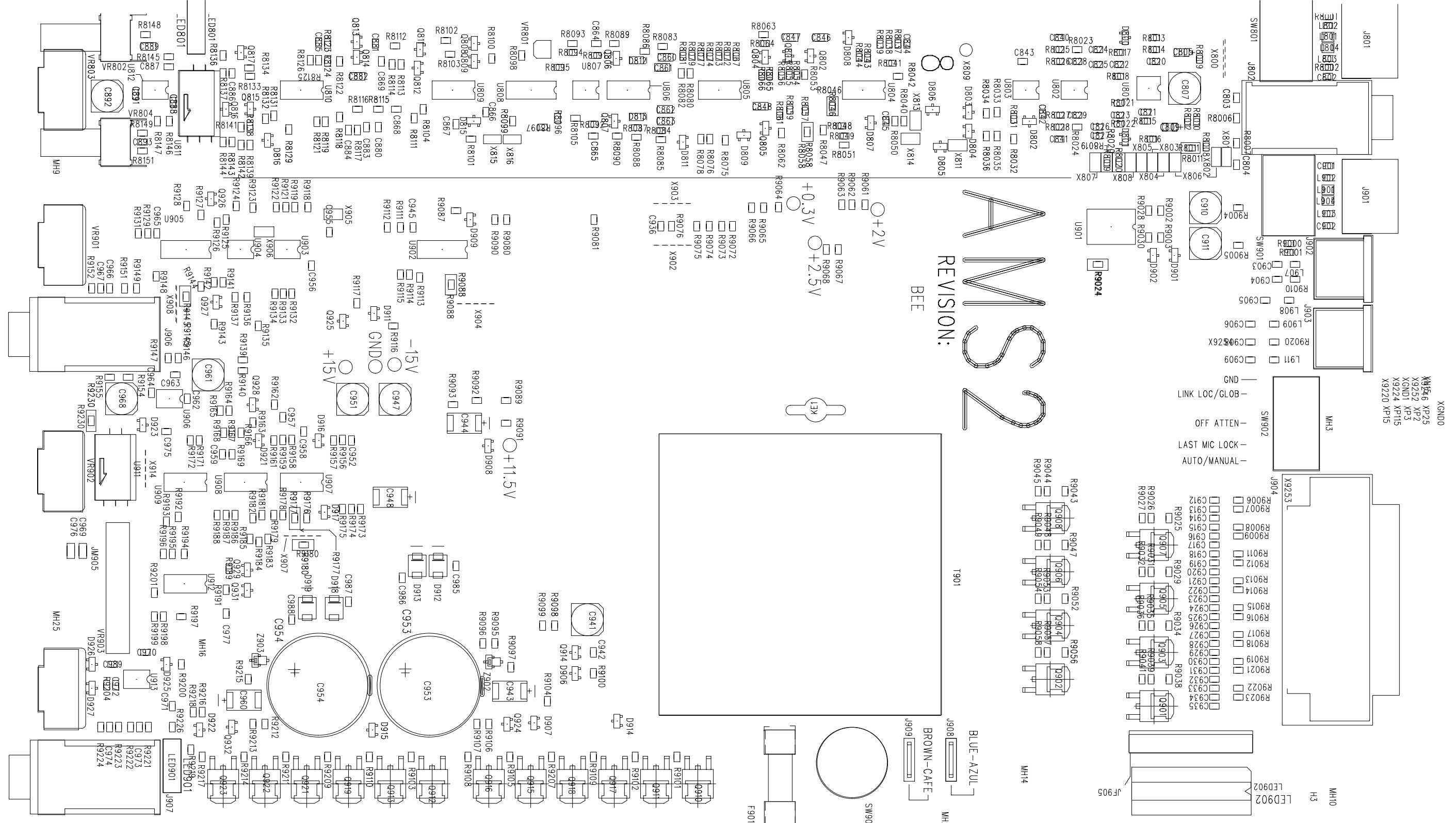

AMS2
REVISION:
BEE

Because Channels 1 – 8 are identical, only Channel 8 is shown in this enlarged view.

Shure AMS8100 Automatic Microphone Mixer
Printed Circuit Board Legend: Enlarged View

Printed in U.S.A.

SHURE®

Service Manual

AMS8100 Automatic Microphone Mixer

Characteristics

General

The AMS8100 is an automatic microphone mixer using Shure's patented Directional Intellimix® that activates only those microphones being addressed, minimizing poor audio caused by multiple open microphones. Each AMS8100 is an eight-channel microphone mixer capable of handling up to eight AMS microphones and two aux-level sources and can be expanded for installations as large as 400 input channels. The AMS8100 microphone mixer works only with Shure AMS microphones and can be linked with Shure's SCM810 and FP410 automatic mixers.

Controls and Connectors

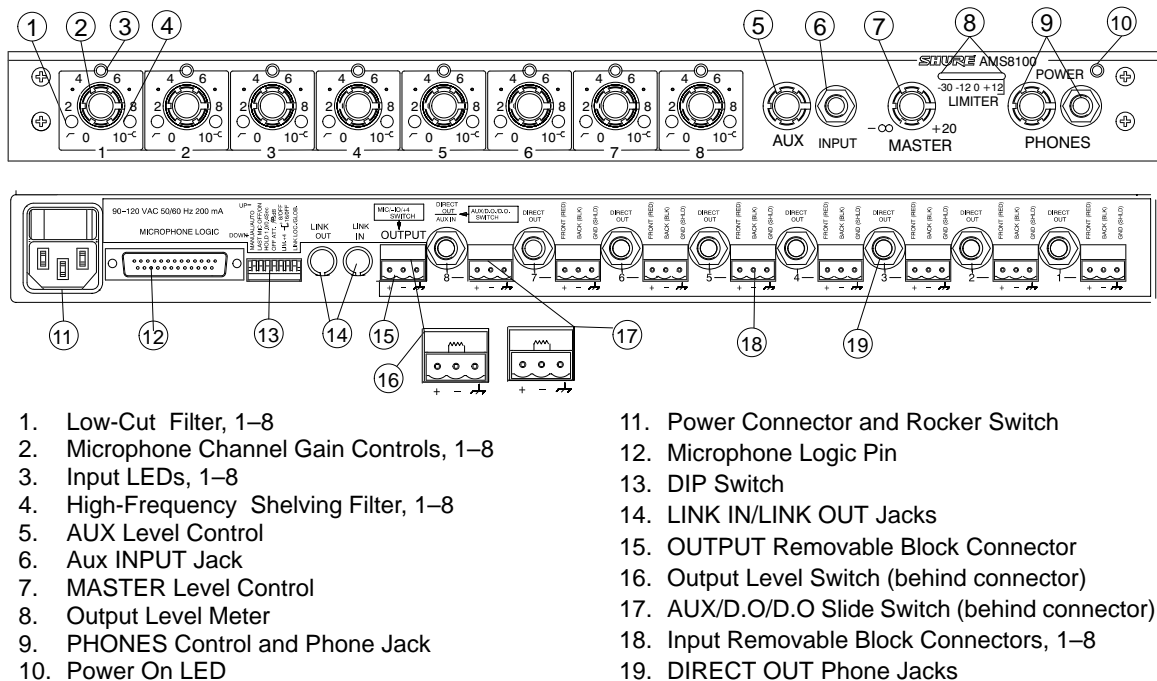

Figure 1. AMS8100 Controls and Connectors

Service Note: Shure recommends that all service procedures be performed by a Factory-Authorized Service Center or that the product be returned directly to Shure Brothers Inc.

Circuit Description

For individual channels, the first number of the reference designator refers to its channel number. For example, R1027 refers to a channel 1 resistor, X7216 refers to a channel 7 jumper, and so forth. Reference designators for the master section are preceded by the number 9 (T901, X901, and so forth).

Because the channels are identical, the channel 8 circuit is used when individual channel circuitry is discussed.

Power Supply

The AMS8100 power supply is a linear supply using discrete transistors for regulation. It converts varying line voltage into well regulated, multiple voltages (+15, -15) for the circuitry to use.

Power is supplied to T901 via the ac connector on the rear panel through its integrated power switch and through the fuse (F901). F901 is a slow-blow type fuse because the power supply pulls a large surge of current on start-up to charge the filter caps. T901 steps the line voltage down to 30 Vac with a center tap connected to ground.

For the +15 Vdc supply, the main 2200 uF filter capacitor, C954, is charged to approximately 20 Vdc through a standard full-wave bridge comprised of D912, D913, D918, and D919. The 1000 pF capacitors across each diode reduce susceptibility to rf signals picked up through the ac power cord.

R9216 and R9218 provide current to the zener diode, Z903, to establish a fixed 8.2 Vdc voltage. Q932's base is connected to Z903 via a resistance-capacitance (RC) filter to reduce noise from Z903. Q932's emitter follows the base voltage, minus about .5 Vdc.

R9212 and R9213 force Q932 to pull current through Q919, Q921, Q922, and Q923 to turn them on. These transistors then are biased through R9219 so that the big transistors' collectors provide a stable +15 Vdc. R9209, R9211, R9214, and R9217 help prevent current hogging between the big output transistors.

The -15 Vdc supply operates the same as the +15 Vdc supply, but the polarities are reversed.

D915 and D922 provide reverse voltage protection to the transistors when the unit is turned on and off.

Microphone Preamps

The microphone preamps convert the current signals from the two microphone elements of an AMS microphone into voltage signals.

The microphone preamps are only suitable for use with Shure AMS microphones. Conventional, balanced microphones usually have about a 150 Ω impedance and supply a small voltage for a conventional microphone to amplify.

However, AMS microphones are unbalanced, have two microphone capsules per microphone, have high impedance outputs, and supply a current output. Each output from the AMS microphone, taken between the red conductor and shield and between the black conductor and shield, has an approximate equivalent output impedance of 51 k Ω .

U801 and associated components form two identical preamps; one for the front microphone capsule, and one for the rear microphone capsule. Both channels are simple current to voltage converters with R8015 and R8014 determining the gain.

Bias for the microphones is supplied from the 7.5 Vdc supply via R8012 and R8009. L801–L804, R8001–R8002, and C801–C802 form a broadband rf filter to keep rf from getting into the subsequent circuitry.

After the microphone preamp, the signal from the front microphone element (from the U801B output) goes through the equalizer (EQ) and then the channel fader gain stage. This gain stage, comprised of U812A and associated components, has a gain of 32 dB (40 times).

Following the channel fader stage is a buffer, U803B, that has a gain of 0 dB (1 times). This buffer is used to lower the impedance of a signal fed into the direct-out jack if it is modified to be a send/return insert.

Channel EQ

Equalizing (EQ) is provided to make different microphones sound similar. The low frequency EQ is a single pole (6 dB per octave) low cut. It is a simple resistance-capacitance (RC) filter comprised of C834, VR802, and R8147. The high frequency EQ is a boost or cut Baxandall type filter. Its frequency and boost, or cut amount, is defined by C836, VR804, R8151, R8152, R8148, and R8149.

Channel LED Circuit

U807C, D816, and surrounding resistors, are hooked up as a full wave peak detector. If the signal at D816, pin 3, reaches about ± 7.5 Vdc peak, U807, pin 14, goes low. When this pin goes low (-15 Vdc), Q814 conducts and pulls current through the red LED inside LED801.

C826 acts as a pulse stretcher to extend the on-time of the LED on peaks.

U807B controls the green section of the LED. U807B, pin 1, is low (-15 Vdc) when the green section of LED101 is off. When U802, pin 7 goes high, then U807, pin 7, goes higher than pin 6, so that U807B's output goes high. This turns the green LED on by pulling R8122 up on Q813's base, turning Q813 on, and pushing current through LED801.

Mixer Circuitry

Directional Intellimix®

The Directional Intellimix® circuitry is the part of the circuit that turns a channel's microphone on or off. Directional Intellimix® has three main sections:

1. Direction-Sensitive AMS Microphones
2. Maxbus
3. Last Mic Lock On Circuit

These sections work together to decide whether the channel's microphone should be turned on or off.

To turn a microphone on, U808, a Light Dependent Resistor (LDR), or optoisolator, goes from high resistance ($> 1\text{ M}\Omega$) to low resistance ($< 1\text{ k}\Omega$). This connects the audio from U801, pin 7, to the main mixing bus (Link A) and sends audio to the output.

To turn a microphone off, U808's resistance goes high so that no audio is passed through it. However, listening to the output of the mixer as normally set up, the microphone will still be heard when it goes off because of the off-attenuation circuit. Instead of turning a microphone completely off, it sounds better to turn it down to only -15 dB from its "on" level. This is done through the Link B mixing bus. The audio signal on this bus is not turned on or off by the Directional Intellimix® circuitry.

Direction-Sensitive AMS Microphones

The heart of the Directional Intellimix® circuitry is the direction-sensitive microphones. Each of these microphones contains two back-to-back cardioid microphone capsules. Each of these capsule's signals is sent separately to the AMS8100 mixer via a three-conductor microphone cable.

These microphones, in conjunction with the microphone-ratio circuitry, determine if someone is speaking within a 120 degree "acceptance angle" in front of an AMS microphone.

The microphone-ratio circuitry is comprised of U802, U807, and associated circuitry. U802A and U802B are two identical bandpass filters that allow voice-band frequencies (300 Hz – 5 kHz) to pass through while attenuating other frequencies.

U807A and U807B form matched one-half wave rectifiers that also convert the signal to a logarithmic dc level representing the input signal.

VR801 is an adjustment pot that changes the dc level at U807, pin 5, effectively changing the “acceptance angle” of the AMS microphone. This angle is factory pre-set to 120 degrees, which is 9.5 dB difference between the front and rear microphone capsules.

Maxbus

The Maxbus tries to turn on only one microphone that hears the same signal. If three microphones are connected to a unit and spoken into, only one microphone should turn on.

The Maxbus circuitry is comprised of U805C, U804B, U803C, and their associated components. The rectified signal from above is fed into the Maxbus circuitry via U805C. U805C steps the signal up by 6 dB (2 times) if a channel is turned on. The signal is then fed to U804B which connects the signal to the actual Maxbus (Link D).

If the signal from a given channel is the highest of all the channels connected to the Maxbus, then the lower half of D815 will be conducting. If the signal is not the highest, then that diode will be reverse biased. U803B checks to see if the diode is conducting. If it is conducting, then the Maxbus criterion has been met, and U803B, pin 1, goes high. If the output of U803B and U803A goes high, the channel will gate on.

Last Mic Lock On

The Last Mic Lock On circuit keeps the last microphone that was activated turned on.

The first sub-block that feeds all of the circuits is the full-wave rectifier circuit comprised of U106 and its associated components. C824, C827, C828, C829, R8115, R8116, and R8117 form a filter circuit that only passes mid-band frequencies. On positive half cycles, U806, pin 2, causes pin 1 to go low, which turns on Q808. This directs all of the current flowing through R8106 down through Q808 and into C823. On the negative half cycles Q808 is turned off, and no current flows through it. The negative half cycles are inverted by U806D and then rectified in the same way as above by U806B. C823, R8107, and R8108 form a filter for the rectified signal. U806C buffers this rectified signal for subsequent circuitry.

Hold Time Circuit

When a channel is allowed to turn on, U803C, pin 8, goes higher than U803C, pin 9. This pulls the output of U803C low, immediately discharging C819. This, in turn, brings U802A, pin 5, lower than U802A, pin 4, causing the output of U802A to go low (ground). This causes the transistors to turn the optoisolator on, thus turning the channel on.

After the channel is on and the decision is made to turn it off, the output of U803C changes to high-impedance. U802A, pin 5, does not immediately go high, however. C819 gets charged up via R8062 and R8061. The channel will go off after the voltage across C819 reaches the level at U802, pin 4 (hold time bus). This is typically about 0.4

seconds. This time is changed by changing the DIP switch setting to 1.0 seconds, which raises the voltage at U802, pin 4.

Optoisolator Turn-On Circuit

When U802A's output is pulled to ground to turn the circuit on, C818 and C817 are immediately discharged. This pulls current through R1063 and R8064, which pulls their current through the base-emitter junction of Q806. Q806 and Q805 are connected as a current mirror, so that Q805 turns on along with Q806 and sends a proportionally higher current through U808's LED. The current through U808 makes its internal resistors go to a low-resistance, letting the audio pass. The current through U808's LED also passes through R8057, providing a voltage for the logic circuitry that a channel is on.

When the channel turns off, the output of U802A goes to high impedance and allows C817 and C818 to be slowly charged up by R8064 and R8063, respectively. This tapers the current down smoothly through the base-emitter junction of Q806, in turn tapering the current through the optoisolator and giving the audio through the optoisolator a smooth fade out.

Last Mic Lock On Circuit

U803D and its associated components comprise the last mic lock on circuit. When a channel turns on, U802A's output pulls D811, pin 3, to ground. This creates two voltages at U803D, pin 10 and pin 11, due to resistive dividers formed by R8076, R8075, R8084, R8083, and R8087. R8087 is in the master section and is connected via the Last Mic Lock On Bus (Link F). The voltages at U803D, pin 10 and pin 11, for a channel when it is the only channel on, are 7.5 Vdc and 6.0 Vdc, respectively.

In this condition, U803D, pin 10, is higher than U803D, pin 11, causing U803D's output to clamp to ground. This locks the channel on, even if U803C's output goes high-impedance.

If two microphones are on at the same time, the voltages at U803D, pins 10 and 11, change to 5.0 Vdc and 6.0 Vdc, respectively, due to the loading of more resistors on Link E. In this state, U803D, pin 10, is lower than U803D, pin 11, and this causes the output of U803D to go high-impedance. At the instant that one of the microphones goes off, the voltages will go back to 7.5 Vdc and 6.0 Vdc, clamping U803D on again, and locking on the last channel.

More than two microphones behave in the same way that two microphones do. The more microphones that come on, the lower the voltage at U803D, pin 10, drops. The last mic lock on circuit can be defeated by changing one of the DIP switches. This grounds the Link F bus so that U803D can never turn on.

Logic Circuitry

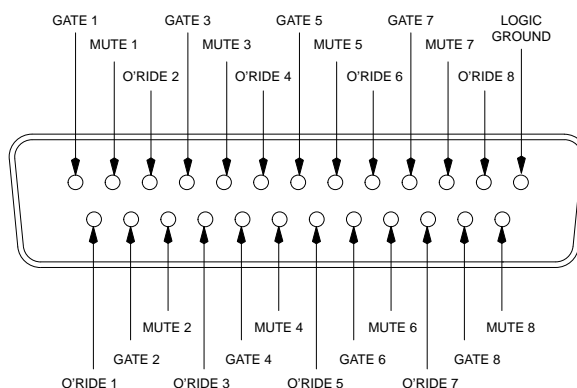

Figure 2. Logic connector

The logic circuitry allows a user to remotely force individual microphones off or on, or to get a signal as to which microphone is turned on. The user accesses these functions via the Microphone Logic 25-pin connector on the rear of the unit. The MUTE (to force a microphone off) and OVERRIDE (to force a microphone on) inputs are standard transistor-transistor logic (TTL) compatible inputs that are active when pulled low (below 0.8 Vdc).

The GATE output is an open-collector transistor output tied to +5 Vdc through 10 k Ω . The GATE terminal goes low (sinks current) when a channel is on.

The MUTE terminal for each channel goes through a 3.01 k resistor and a .047 μ F capacitor near the 25-pin connector before going to the channel circuitry. These are to bypass rf.

U802D and its associated components form the main MUTE circuitry. When the MUTE signal is pulled low, D804, pin 1 and pin 3, are pulled low. This allows U802, pin 11, to drop to 2.0 Vdc. This drops U802, pin 11, lower than U802, pin 10 (2.5 Vdc), causing U802D's output to clamp to ground. R8050 and C814 slow down this clamped signal so that it doesn't make a tick in the audio circuits.

When this signal goes low, it does several things. First, it pulls U802, pin 8, low, so that U802C cannot turn on, disabling the OVERRIDE function. Second, it mutes the Link A audio by turning on Q807, which immediately kills any current going to U808, the optoisolator, causing its resistance to go high. Third, U802A (the main gating comparator) and U803D (the last mic lock on) are disabled via Q810 and U805B, respectively. The channel reacts to it as if it were off, and another channel can turn on, in case the muted channel was the only microphone that was on. Fourth, the Link B audio is muted, accomplished via U807A and Q815/Q816.

When the output of U802D goes low, U807, pin 5, is pulled low, causing U807A's output to go low. This, in turn, pulls the gates of Q815 and Q816 to about -12.5 Vdc, causing the junction field-effects transistors

(JFETs) to go high-impedance between their source and drain pins. Q817, C830, R8130, and R8135 again are for de-ticking.

The OVERRIDE terminal for each channel works similarly to the MUTE until the output of U802C. When this point pulls low, current is pulled through D806, clamping the output of U803C to ground, and turning the channel on.

The GATE circuitry is comprised of U802B, Q901 (near 25-pin connector), and its associated components. When current flows through U808 (channel on), current also flows through R8057, which creates a voltage across R8057. When this voltage goes above about 150 mVdc, U802, pin 7, is higher than U802, pin 6, causing U802B's output to go high-impedance.

When the channel is off, U802B's output is clamped to ground. When this happens, R8041 and R8042 provide current to Q901's base to turn Q901 on. R8043 provides hysteresis so that U802B does not buzz when turning on or off.

Mix Stage

The mix stage mixes the audio from the channels to go to the output stage.

Link A is the gated audio signal from the output to the optoisolator for each channel. Each channel has a 4.99k resistor following the optoisolator; after this resistor is Link A. When a new channel turns on, the impedance of Link A drops, because of the additional 4.99k resistors on the bus. This lowering of impedance drops the audio level on Link A. This effect performs the number of open microphones attenuation (NOMA).

As more microphones come on, the level of audio coming out of the mixer should be dropped. R9125 and R9126 are grounded via Q926 when mixers are unlinked. These resistors set the proper impedance for Link A. U904A is a non-inverting gain stage that feeds the signal to the master stage.

Link B operates similar to Link A, except that the audio is not gated, and the impedance and level of this bus are lower.

Link A Local and Link B Local perform identically to the normal Link A and B, except that this bus is not connected to the link jacks, and thus is not linked to other mixers. When mixers are linked, the Global/Local DIP switch selects which of these mix stages connects to the output stage. U905 performs this switching.

When the Off-Attenuation switch is set to minus infinity, Link B is switched out of the audio. This switching is done by U902C and U905C.

Master Gain Stage and Output

The master gain stage is U906B and its associated components. The master gain stage is an inverting gain stage.

The output stage is U901 and its associated components. The SSM-2142 chip is an active balanced line driver. The ac output voltage seen across U901, pin 3 and pin 14, is 6 dB higher than the input voltage at pin 6. If either the positive (+) or negative (-) pin at the output is grounded, the output across U901, pins 3 and 14, will stay the same. C910 and C911 protect the chip from phantom power. C901, C902, L901, L903, L903, and L904 are for rf filtering.

Limiter

The limiter circuit prevents the output stage from clipping and keeps the maximum peak output level below a certain level set by the user. The limiter is a high quality, full-wave peak limiter with a high limiting ratio. It has a very fast attack time (about 4 mS) and relatively slow decay time (100 mS). U911, an optoisolator, performs the actual gain adjustment, but the limiter circuit provides the dc control voltage necessary for the optoisolator's action.

U907A, U907B, and associated components, form a full-wave peak rectifier with 6 dB of gain. This rectified signal is fed to U907D and its surrounding components, which is an inverting gain block with different gains set by the limiter DIP switch. These different gains manifest themselves as different limiter thresholds. When this amplified rectified signal's level reaches a certain level, current will flow through D923, U911's LED, and R9186. This current flowing through U911's LED causes U911's resistor to drop in value, which lowers the gain of U906B.

This current also generates a voltage across R9186. When this voltage goes below -15 mV, U908C's output will clamp to -15 Vdc. This turns off U908B, which turns off Q928. This allows current to flow through the limiter LED segment on LED902. C959, R9169, and U908B act as a pulse stretcher to extend the "on" time of the limiter LED.

Output Meter

The output meter gives a visual indication to the ac voltage level at the line output connector. The meter is a full-wave, peak-responding type with a relatively slow decay.

The rectified output signal as provided by U907A and U907B is fed into U907C. U907C is a half-wave rectifier/ buffer. When the signal at U907, pin 12, is higher than the voltage across C948, then U907, pin 14, swings higher, causing current to flow through D917 and R9173, thus charging C948. When the voltage at pin 12 is lower than the C948, C948 is discharged through R9173, R9174, R9175, and D917. The output of U907C sinks this current.

Shure AMS8100 Automatic Microphone Mixer

The voltage across C948 is fed to the string of comparators, U908, U909, and U912. When the outputs of these comparators are low (–15V), the individual LEDs of LED902 are off.

Q929, Q931, R9189, and R9191 form a current source. This current is consumed by the comparator outputs until they go high-impedance, one by one. This allows this current to flow through the LED segments one by one.

Mixer Link Circuitry

The link circuit allows two or more mixers to be interconnected.

When two mixers are linked “Link Out to Link In, several busses get tied together directly: Link A, Link B, Link D (Maxbus), Link E (Reverb Inhibit), Link F (Last Mic Lock On), and Aux In Bus.

In all but one mixer of a linked system, certain elements must be switched out to maintain proper bus impedances: R9087 (Link F bus); R9125, R9126 (Link A bus); and R9141, R9142 (Link B bus).

Pin 2 of the link connectors is the link sense pin. When pin 2 of the Link Out jack is grounded (mixers are linked), Q925 is turned on. This pulls the gates of Q926 and Q927 low (–14 Vdc), which makes these JFET high-impedance between their source and drain pins. Q925 also switches U902B, which takes R9087 out of the circuit.

Disassembly and Assembly



! CAUTION !

Observe precautions when handling this static-sensitive device.



! WARNING !

Voltages in this equipment are hazardous to life. No user-serviceable parts are inside. Refer all servicing to qualified service personnel. The safety certifications of the AMS8100 do not apply when the operating voltage is changed from the factory setting.

Front Panel Pots

In this state of disassembly, most components can be accessed and the mixer can be powered and work properly. To replace front panel pots:

1. Do *not* remove any of the snap-in LEDs from the front panel.
2. Remove the top and bottom covers.
3. Remove the six nuts behind the front panel
4. Remove the two nuts and washers on the front panel phone jacks.
5. Remove the four screws holding the front panel to the chassis.
6. Carefully lift the front panel out of the way (with the snap-in LEDs still connected).
7. Loosen the pot to be replaced.
8. Desolder the pot, lift it out, and install new pot.
9. Reassemble the unit in reverse order.

Front Panel Phone Jacks

1. Disassemble as above, through step 6.
2. Remove all nuts holding pots to the pot bracket.
3. From the bottom of the printed circuit board (pcb), remove the three screws and two standoffs holding the pot bracket to the pcb.
4. Slide the pot bracket forward and remove it.
5. Replace the jacks and reassemble the unit in reverse order.

Rear Panel Connectors

1. Remove the top and bottom covers.
2. Remove the four screws from the front panel that hold the front panel to the chassis.
3. Remove the five screws holding the printed circuit board (pcb) to the chassis through the holes in the top of the chassis.
4. Remove the eight nuts and washers holding the rear panel phone jacks to the chassis.
5. Unplug the blue and brown power wires from the pcb.
6. Remove the chassis from the unit, replace the parts, and reassemble the unit in reverse order.

Service Procedures

Reference Material

Refer to the *Service Equipment Manual* for standard test equipment.

Changing the Voltage

The AMS8100 can be internally modified to operate from either 120 Vac or 230 Vac power. Follow these steps to change the operating voltage:

1. Disconnect the unit from the ac power source.
2. Remove the eight Phillips head screws to remove the top cover.
3. Locate voltage selector switch SW903 adjacent to the power transformer (T901).
4. Use a screwdriver to turn the center rotor to the 230 V position for 230 V operation, or to the 120 V position for 120 V operation.
5. Locate fuse F901 and remove it.
6. Replace fuse F901 with a 100 mA, 250 V, time-delay fuse for 230 V operation, or a 200 mA, 250 V, slow-blow fuse for 120 V operation.
7. If changing to 230 V operation, replace the power cord with a cord rated for 230 V operation (an IEC appliance connector on the equipment end and a CEE 7/7 Schuko mains connector on the other end).*
8. If changing to 120 V operation, replace the power cord with a cord rated for 120 V operation (an IEC appliance connector on the equipment end and a mains connector suitable for 120 V operation on the other end).*

*For systems that require other mains connectors, obtain a power cord with an IEC 320 type mating connector for connection to the unit, and an appropriate plug on the other end for connection to the mains.

Product Specifications

After all tests are completed, the unit should perform to the following specifications.

Measurement Conditions (unless otherwise specified)

- Line voltage: 120 Vac, 60 Hz (230 Vac, 50 Hz)
- Full gain: 1 kHz, one channel activated
- Source impedances: Mic 150 Ω , Line 150 Ω
- Terminations: Line, 10 k Ω ; Phones, 300 Ω (tip-sleeve and ring-sleeve); Direct Out, 10 k Ω
- Auto mode: Equalization controls adjusted for flat response

Frequency Response (Ref 1 kHz, channel controls centered)

80 Hz to 20 kHz ± 2 dB; -3 dB corner at 25 Hz

Voltage Gain

Controls at full clockwise

Input	Output:				
	Mic	Aux	Line	Headphones	Direct Out
AMS26 mic (72 dB SPL in):	-20 dB	+5 dB	+20 dB	—	-38 dBu
Aux:	4 dB	29 dB	44 dB	52 dB	—
Send / Return:	-20 dB	5 dB	20 dB	28 dB	—

Inputs:

Impedance:

Input:	Designed for use with:	Actual (typical):	Input Clipping Level:
Mic:	AMS Mics only	400 k Ω	+132 dB SPL
Aux:	$\leq 2 \Omega$	10 k Ω	+ 24 dBu
Send / Return:	$\leq 2 \Omega$	100 k Ω	+ 20 dBu

Outputs:

Impedance:

Output:	Designed for use with:	Actual (typical):	Output Clipping Level:
Line:	> 600 Ω	60 k Ω	+ 24 dBu
Headphones:	8 – 200 Ω , 60 Ω recommended	1 k Ω	+ 6 dBu
Direct Out:	> 2 Ω	1 k Ω	+ 18 dBu
Send / Return:	> 2 Ω	1 k Ω	+ 18 dBu

Total Harmonic Distortion

<0.1% at +18 dBu output level, 80 Hz to 20 kHz (through 80 Hz – 20 kHz filter; Input 1 and Master at 5; all other controls at full counterclockwise.

Hum and Noise

Equivalent Input Noise: 27 dBu (A-weighted)

Output Hum and Noise: through 20 Hz to 20 kHz filter, channel controls full counterclockwise; Master full counterclockwise, –90 dBu; Master full clockwise, –65 dBu

Polarity

Mic/Line: send inputs to all outputs are non-inverting; Aux input to all outputs is inverting.

Input Channel Activation

Attack time: 4 msec

Hold time: 0.4 sec (switchable to 1.0 sec)

Decay time: 0.5 sec

Off-Attenuation

15 dB (switchable to ∞)

Overload and Shorting Protection

Shorting outputs, even for prolonged periods, causes no damage. Microphone inputs are not damaged by signals up to 3 V. Line and monitor inputs are not damaged by signals up to 20 V.

Equalization

Low-frequency: 6 dB/octave cut, adjustable corner from 50 Hz to 300 Hz

High-frequency: ±6 dB at 5 kHz, ±8 dB at 10 kHz, shelving

Limiter

Type: Peak

Threshold: Switchable: off, +4, +8, +16 (dBu at output)

Attack time: 2 msec

Recovery time: 300 msec

Indicator: Lights red when limiting occurs

Input LEDs

Green on channel activation, red at 6 dB below clipping.

Notes

This page intentionally left blank.

Bench Checks

Power Supply

General

- ✓ Check to see if F901 is not blown. If it is blown, check the unit to see why it blew. If nothing can be seen, replace F901 and slowly bring the ac power up with a Variac while monitoring the supply rails. If any of the supplies appear shorted, remove power and do more troubleshooting of the circuitry.
- ✓ Check for about 40 Vp-p at the secondary of T901. The signal should look like a sine wave with flattened peaks. If it is not there, suspect T901, SW903, F901, the wires to the ac power connector, the ac power connector, or the printed circuit board.

± 15 Vdc Supply

- ✓ Check for about +20 Vdc across C954 and across C953. This signal will have a ripple on it. If this voltage is not there, there may be a short in subsequent circuitry, the diodes feeding these capacitors may be open, or the capacitors themselves may be shorted.
- ✓ Check for 8.2 Vdc across Z903 and Z902. If not there, the zener diodes may be shorted.
- ✓ Check for 7.7 Vdc at Q932's emitter and -7.7 Vdc at Q924's emitter. If not there, Q932 or Q924 may be bad.
- ✓ Check for about 1.2 Vdc across the base emitter of Q919 and Q915. If not there, Q919 may be bad.

Channel EQ

- ✓ Apply a signal to the mic/line input.
- ✓ Check for the signal at U801 pin 1.
- ✓ Check for the signal on the other side of C834.
- ✓ Check for the signal at U809 pin 7.

Notes

This page intentionally left blank.

Replacement Parts and Drawings

Parts Designations

The following comments apply to the parts list and the schematic:

The first number of the reference designator refers to its channel number. For example, R1027 refers to a channel 1 resistor, X7216 refers to a channel 7 jumper, and so forth. Reference designators for the master section are preceded by the number 9 (such as T901, X901, and so forth).

Resistors: All resistors are surface-mount with $\frac{1}{10}$ W rating and 1% tolerance.

Capacitors: Unless otherwise noted, non-polarized capacitors are surface-mount NPO dielectric types with a 100 V capacity and a 5% tolerance, and polarized capacitors are tantalum or electrolytic types.

Table 1
Replacement Parts

Reference Designation	Description	Shure Part Number
A1	Printed circuit board assembly	90A8667B
C953,954	Capacitor, leaded, 3300 uF 20% 35V	86PD8982CD
F901	Fuse holder, 5 x 20 mm	80A8008
J102,202,302, 402,502,602, 702,802,906, 907	Phone jack, stereo, 13mm	95Z8322
J902,903	Connector, Mini-Din	95A8224
J908,909	Connector, .187 spade	56A8064
JF905	Connector and ribbon cable assy	95K8697G
LED101,201, 301,401,501, 601,701,801, 901	LED, bi-color (green/red)	95A8619
LED902	LED, bargraph, 10 segment,	86A8972
SW801, 901	Switch, slide, 3-position, DPTT	55A8022
SW902	Switch, side actuated DIP, 7PST	55F8052
SW903	Switch, rotary, voltage selector	55A8054
T901	Transformer, power	51E8056
W1	Line cord, ac, 2m (6 ft, 7 inches), AMS8100	
W2	Line cord, ac, 2.5 m (8 ft, 4 inches), AMS8100E	

Table 2
Surface Mount Components

Reference Designation	Description	Shure Part Number
D100-102,105, 107,109,115,116, 200-202,205,207, 209,215,216,300- 302,305,307,309, 315,316,400-402, 405,407,409,415, 416,500-502,505, 507,509,515,516, 600-602,605,607, 609,615,616,700- 702,705,707,709, 715,716,800-802, 805,807,809,815, 816,901,902,907, 909,914-917, 921-923,925-927	Diode, switching, dual	184A08
D103,104,203, 204,303,304,403, 404,503,504,603, 604,703,704,803, 804,906	Diode, switching, dual	184A07
D106,108,111, 206,208,211,306, 308,311,406,408, 411,506,508,511, 606,608,611,706, 708,711,806,811, 911	Diode, switching, dual	184A03
D112,113,212, 213,312,313,412, 413,512,513,612, 613,712,713,812, 813	LED, surface mount	184A18
D912,913,918, 919	Diode, power	184A20
L101,104,201, 204,301,304,401, 404,501,504,601, 604, 701,704,801, 804,901,904	Inductor, 100 uH	162BN18K
L102,103,202, 203,302,303,402, 403,502,503,602, 603, 702,703,802, 803,902,903,907, 908,909,911	Ferrite bead, surface mount	162A12
JM905	Connector, SMT top entry	170J10

Shure AMS8100 Automatic Microphone Mixer

Reference Designation	Description	Shure Part Number
Q102-109,111-112,114,117,202-209,211-212,214,217,302-309,311-312,314,317,402-409,411-412,414,417,502-509,511-512,514,517,602-609,611-612,614,617,702-709,711-712,714,717,802-809,811-812,814,817,924,928-929,931	Transistor	183A01
Q115,116,215,216,315,316,415,416,515,516,615,616,715,716,815,816,926,927	Transistor, JFET, N channel	183A22
Q901-908,910-911,915-918	Transistor, Darlington NPN	183A24
Q912-913,919,921-923	Transistor, Darlington PNP	183A34
U101,201,301,401,501,601,701,801	Dual Op-Amp	188A58
U102,103,107,112,202,203,207,212,302,303,307,312,402,403,407,412,502,503,507,512,602,603,607,612,702,703,707,712,802,803,807,812,903,904,906,913	Dual Op-Amp	188A18
U104,105,110,204,205,210,304,305,310,404,405,410,504,505,510,604,605,610,704,705,710,804,805,810,908,909,912	Quad Comparator	188A123
U106,206,306,406,506,606,706,806	Transistor Array	188A263
U108,208,308,408,508,608,708,808,902,905	Analog switch, 3X SPDT	188A05
U109,209,309,409,509,609,709,809,907	Quad Op-Amp	188A260
U111,211,311,411,511,611,711,811,911	Optoisolator	86A8969
U901	Balanced Line Driver IC	188A143

Shure AMS8100 Automatic Microphone Mixer

Reference Designation	Description	Shure Part Number
VR102,202,302, 402,502,602,702, 802	Potentiometer, Blue Shaft 50 k 20%	46A8060
VR103,203,303, 403,503,603,703, 803,901-903	Potentiometer 100 k 20%	46A8003
VR104,204,304, 404,504,604,704, 804	Potentiometer, Black Shaft 100 k 20%	46B8060

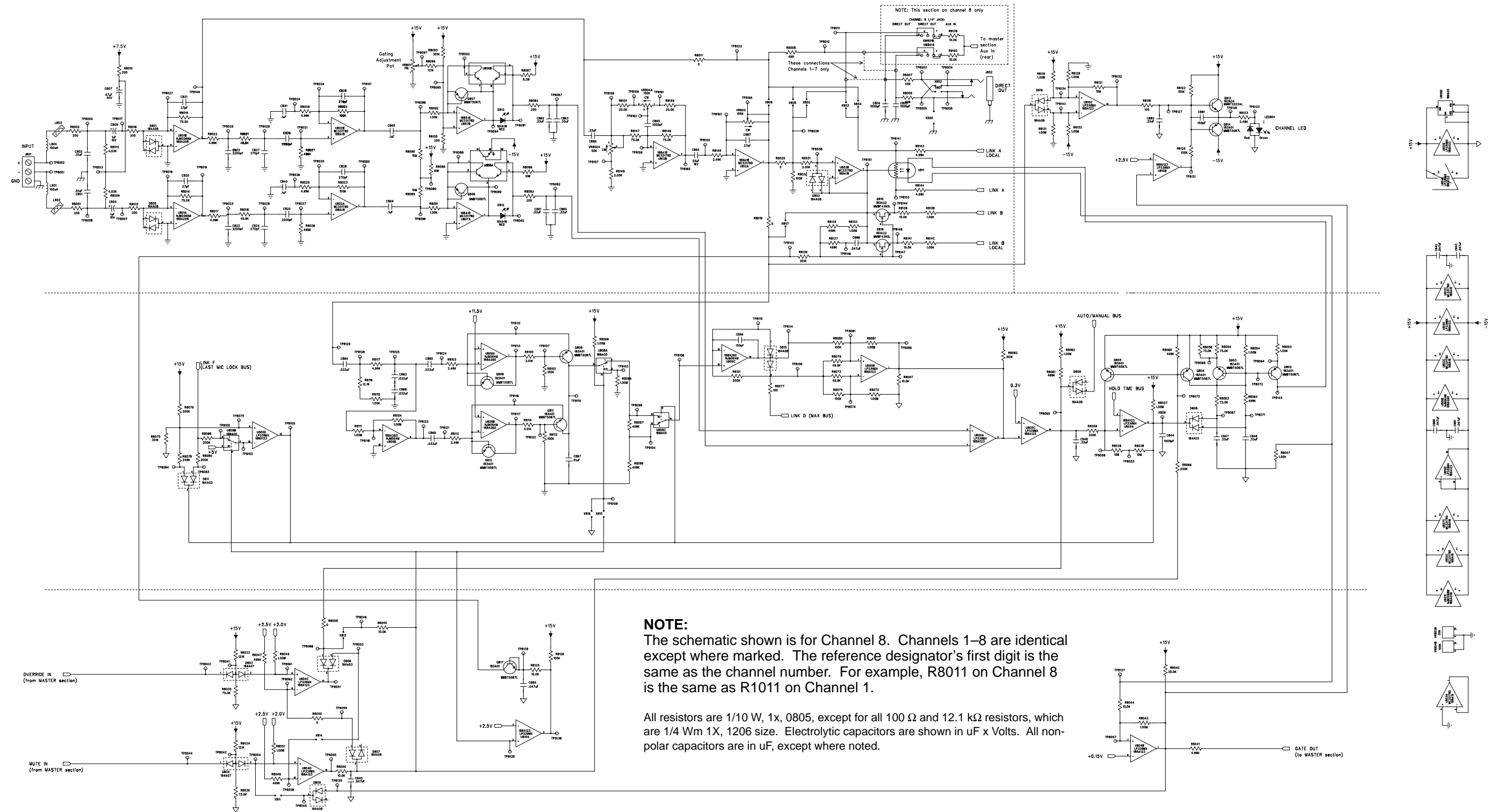

NOTE:
The schematic shown is for Channel 8. Channels 1-8 are identical except where marked. The reference designator's first digit is the same as the channel number. For example, R8011 on Channel 8 is the same as R1011 on Channel 1.

All resistors are 1/10 W, 1x, 0805, except for all 100 Ω and 12.1 kΩ resistors, which are 1/4 Wm 1X, 1206 size. Electrolytic capacitors are shown in uF x Volts. All non-polar capacitors are in uF, except where noted.

AUDIO

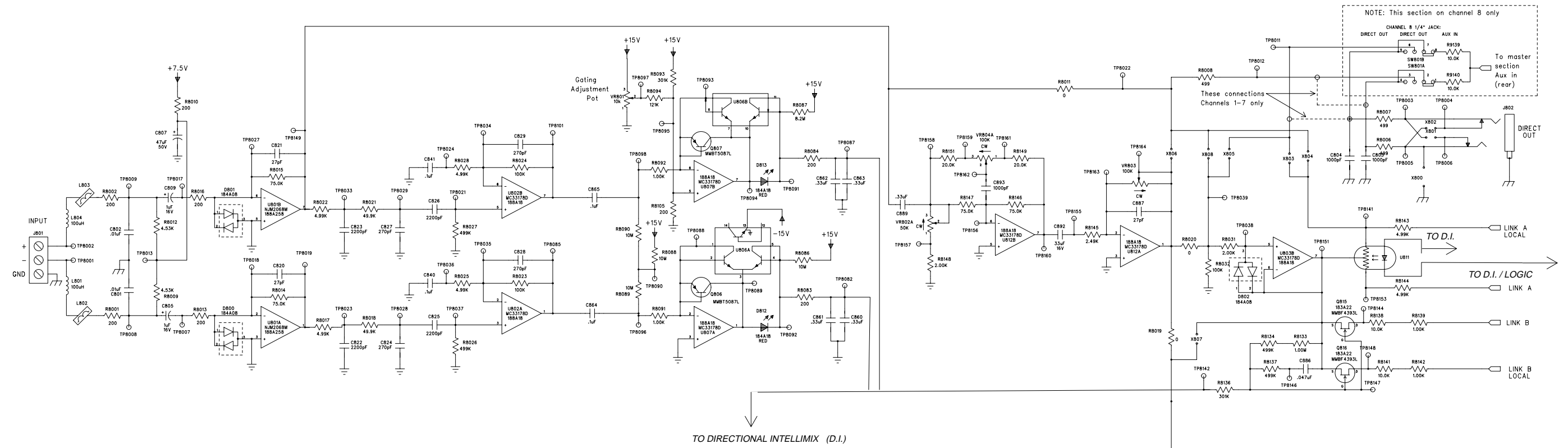

LED CKT.

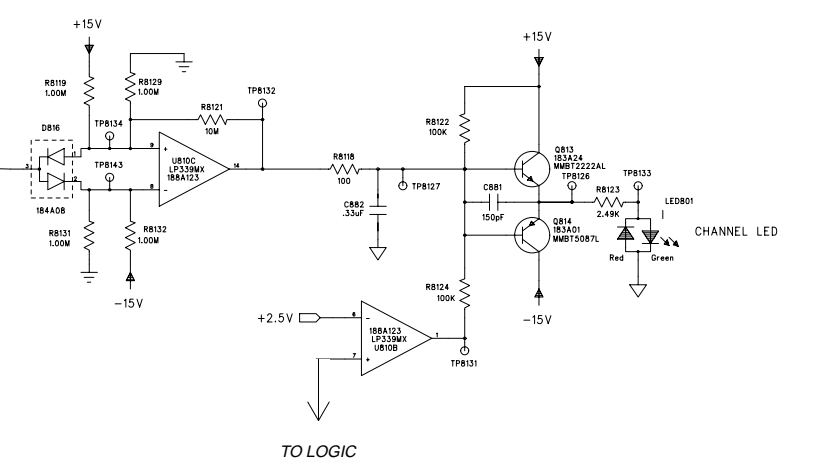

Shure AMS8100 Automatic Microphone Mixer
Individual Channel Schematic
Enlarged View, Page 1

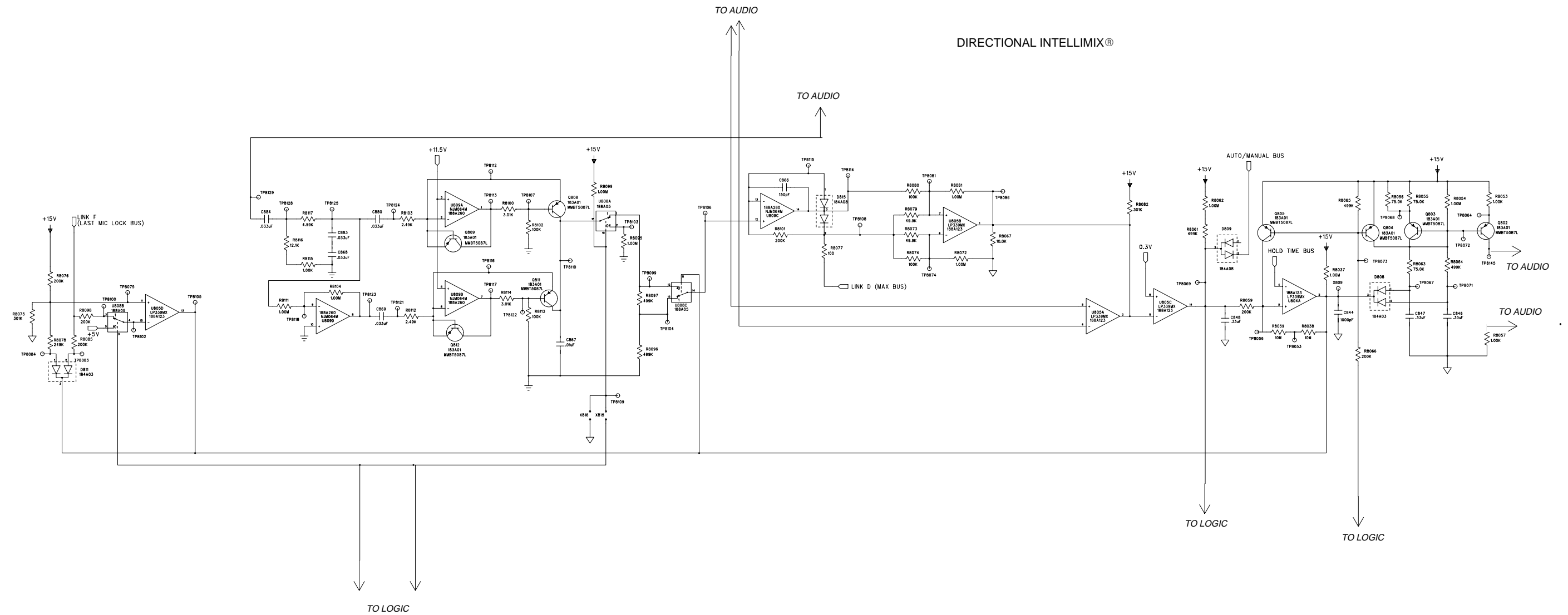

Shure AMS8100 Automatic Microphone Mixer
Individual Channel Schematic
Enlarged View, Page 2

