



Shure Brothers Incorporated
222 Hartrey Avenue
Evanston IL 60202-3696 U.S.A.
LX Wireless System

SERVICE MANUAL CHANGE NOTICE

LX4 DIVERSITY RECEIVER

Changes and corrections have been made to the Service Manual for the LX4 Diversity Receiver. To update your Service Manual, remove the pages identified in the tables below and replace them with the pages attached to this Change Notice. Note that there are no changes to pages not specifically identified in the tables below.

LX4 DIVERSITY RECEIVER SERVICE MANUAL REVISION HISTORY

Release	Part Number	Date Code	Color
Original	25A1008	QH	White
Revision 1	25B1008	QL	Pink
Revision 2	25C1008	SC	Tan
Revision 3	25D1008	SI	White
Revision 4	25D1008	TL	White
Revision 5	25D1008	BK	White
Revision 5	25D1008	DL	Red

CHANGES EFFECTIVE DECEMBER 21, 2004

REMOVE these pages from the LX4 Service Manual	INSERT these pages into the LX4 Service Manual
Pages 26 – 28	Pages 26 – 28

LX4 Diversity Receiver

Characteristics

General

The Shure Model LX4 is a single-conversion superheterodyne diversity FM receiver operating in the 169 to 240 MHz band. It is intended for use with compatible Shure VHF wireless transmitters.

Controls and Connectors

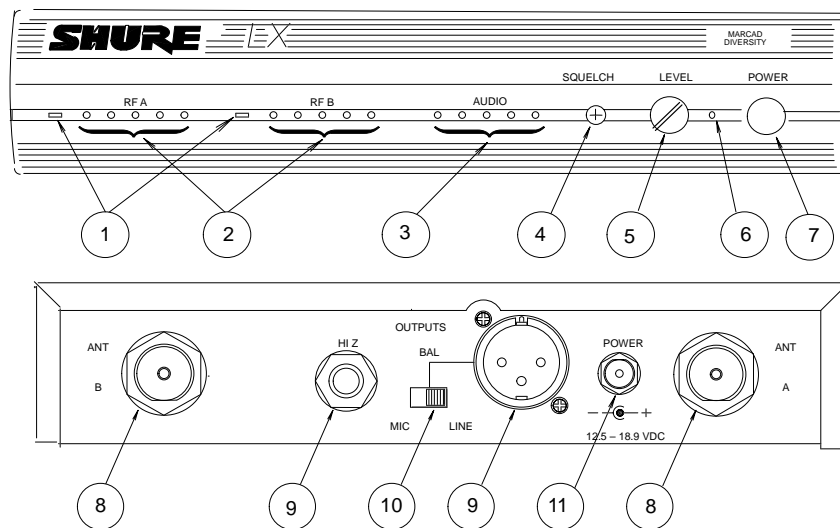

Figure 1. Identification of Controls and Connectors

- | | |
|--------------------------------|---------------------------|
| 1. Diversity signal indicators | 7. Power ON/OFF button |
| 2. Rf level indicators | 8. Antenna connectors |
| 3. Audio level indicators | 9. Output connectors |
| 4. Squelch control | 10. MIC/LINE slide switch |
| 5. Audio level output control | 11. Power jack |
| 6. Power ON indicator | |

Service Note: Shure recommends that all service procedures be performed by a Factory-Authorized Service Center or that the product be returned directly to Shure Brothers Inc.

©1999, Shure, Inc.
Printed in U.S.A.

Licensing: Operation may require a user license. Frequency or power-output modifications may violate this product's approvals. Contact your country's communications authorities.

Circuit Description

The Shure Model LX4 Diversity Receiver is a single-conversion superheterodyne diversity FM receiver operating in the 169 – 240 MHz band. It is intended for use with compatible Shure VHF wireless transmitters, including the Shure LX, L, EC, SC, and T series hand-held and body-pack transmitters.

The LX4 has balanced LO-Z output (3-pin XLR-type connector), an unbalanced aux level audio output (1/4 inch monophonic phone jack), and audio output level (volume) control for all outputs.

The LX4 has an externally-accessible squelch control for signal-to-noise muting system. The recessed potentiometer for squelch control is screwdriver-adjustable.

A one quarter wavelength whip type antenna can be mounted directly to the receiver or to a full rack panel (Shure model WA440), and can then be cabled to the receiver. Also, a Shure model WA404 antenna splitter can be used to provide antenna inputs and dc power to the LX4.

Audio output is a 1/4-inch, single circuit (monophonic) phone jack.

Diversity channel selection and muting are provided by a noise-operated squelch system. Noise signals are obtained from the additional detector outputs at pin 9 of U100 and U200. For diversity channel A, the noise signal is adjusted by squelch level control R130 before amplification by U1B. Active high-pass filter U1C removes audio components that could cause false triggering. The noise is then rectified by D2 and smoothed by C18 to provide a dc voltage that varies in accordance with the amount of noise present on the detected signal.

An identical scheme is followed for diversity channel B, where noise signals are adjusted by squelch level control R230 before being amplified by U2B, filtered by U2C, rectified by D1, and smoothed by C17.

Two diversity peak A/B (yellow) LEDs are located on the front of the unit illuminate to indicate which diversity channel (A, B, or both) have been selected by the receiver. When the quality of the received signal is below the squelch threshold level, both LEDs are extinguished. Audio peak LEDs illuminate when the deviation level of the received signal exceeds the following deviation:

LED Color	Deviation kHz
1 – Green	1.5
2 – Green	4.0
3 – Green	7.0
4 – Amber	11.0
5 – Red	14.0

Diversity Control Signals

The dc noise signals are compared by U3A, U3B, U3C, and U3D to produce diversity control signals. These signals directly control analog switches U6A and U6B, and diversity A/B LEDs D9 and D10. These switches control the flow of audio signals from U1A and U2A.

Squelch Control

Squelch comparators U3A and U3C compare a dc level from the user squelch control, R66, to the dc noise level signals coming from each diversity channel. When the noise level in both channels exceeds a preset level, the audio output of the receiver is squelched. Comparator U4A provides additional signal attenuation in the squelched state by shutting off compander U9B.

However, if the noise level in each channel is comparable and below the squelch threshold, then U3B and U3D will allow both channels to be active and both diversity indicators will be illuminated. Because the signals from each channel are correlated, but the noise is uncorrelated, a theoretical signal-to-noise improvement of 3 dB is possible with this arrangement.

Balanced LO-Z Output

After passing through analog switches U6A and U6B, audio signals from the two channels are buffered by U5A before entering three-pole, low-pass filter Q1. They then enter compander U9B, which provides 2:1 logarithmic expansion. An additional IC amplifier U5B operates in conjunction with U9B to provide a lower noise floor. The output of this stage is applied to volume level control R32. In order to provide a balanced LO-Z output, U5C and U5D operate as a bridging amplifier. HI-Z audio output connector J3 taps off U5D output.

Audio Indicators

An audio LED indicator display lets the user know when the transmitter (and audio level) deviation is approaching the limit of 15 kHz. This function is implemented by the U11 display chip. Two rf level LED strings are provided to indicate relative rf strength of transmitters received by each antenna. They are powered by display chips U10 and U12, which are controlled by U100 and U200 signal strength pins.

Independent Rf Sections

Two complete, independent rf sections are provided for diversity reception. Signals enter the receiver via detachable, single-element quarter-wave antennas. For diversity channel A, they pass through a filter that is double-tuned by L100 and L101 before entering dual gate MESFET amplifier Q100. The output of this stage is triple tuned by L103, L104, and L105, which filter the signals before they enter gate 1 of MESFET mixer Q101. The local oscillator (LO) signal, which is applied to gate 2 of Q101, is provided by transistor Q104. A third- or fifth-overtone quartz crystal in the 50 to 70 MHz range is used to provide frequency control. The collector circuit of the oscillator is tuned by L113 and L114 to the third harmonic of the crystal (150 to 210 MHz) to provide the correct injection frequency for a 10.7 MHz intermediate frequency (IF).

The output of mixer Q101 is tuned to 10.7 MHz by L108 before being applied to ceramic filter FL100. Transistor Q102 provides IF amplification to make up for filter losses. Signals then pass through a second IF filter, FL101, before entering the integrated circuit IF amplifier/detector, U100. The detected audio is taken from pin 8 and is then amplified by operational amplifier U1A.

Rf Channel B

Diversity channel B is identical in design to channel A. Signals first pass through a double-tuned filter consisting of L200 and L201 before entering amplifier Q200. The output of this stage is triple-tuned by L203, L204, and L205 and fed to gate 1 of mixer Q201. LO injection is provided by buffer transistor Q103, which is tuned by L112 and L111 to the third harmonic of the crystal frequency. The buffer stage helps to isolate the diversity channels from one another by preventing crosstalk through the common LO section.

The output of mixer Q201 is tuned to 10.7 MHz by L208 before being applied to ceramic filter FL200. Signals are then amplified by transistor Q202 before passing through the second ceramic filter, FL201, before they enter the integrated circuit IF amplifier/detector U200. The detected audio is again taken from pin 8 and is amplified in this case by U2A.

Rf Indicators

Rf LEDs indicate approximate rf signal strength for each channel:

LED	Signal Strength, dBm (± 10 dBm)
1	-95
2	-90
3	-80
4	-65
5	-60

Power

The Shure LX4 Diversity Receiver operates on 12.5 – 18 Vdc or from an ac power line with 120 Vac, 60 Hz external power converter; or 220 to 240 Vac, 50/60 Hz for export models. The dc power connector: is a male pin coaxial jack with locking connector.

A green power LED, D11, indicates when power is being supplied to the receiver by an external power converter. The circuitry will operate normally with an input of 12.5 to 18 Vdc. Reverse polarity protection is provided by D8, and voltage regulation is accomplished by U7. The power input, HI-Z and balanced LO-Z output connectors are filtered to prevent local oscillator radiation from the cables and to protect the receiver from the effects of external electromagnetic fields.

Notes:

Preliminary Tests

Listening Test

Before completely disassembling the receiver, operate it to determine whether it is functioning normally and try duplicating the reported malfunction. Refer to the *User Guide* for operating instructions, troubleshooting suggestions, and specifications.

Review any customer complaint or request, and focus the listening test on any reported problem. The following, more extensive, functional tests require partial disassembly.

Functional Tests

Refer to the *Disassembly* section to partially disassemble the receiver for the following functional tests.

Use dc blocks at all rf output to protect test equipment.

Verify operation and reported malfunction, referring to the product User's Guide for a description of the unit as well as information on its operation, troubleshooting, and technical data.

Rf Test

Receivers that pass this test do not contain any “drop-out” or “range” problems.

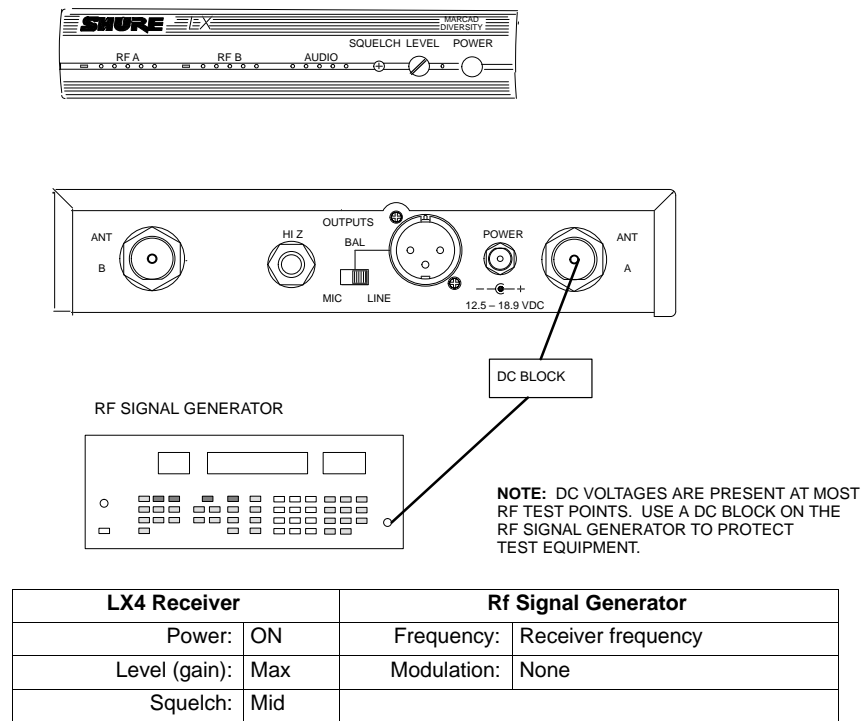

Figure 2. Rf Alignment Functional Test Set-Up

For channel A:

1. Set the receiver’s squelch control to its middle position and the volume control to its maximum position.
2. Set the rf generator to the receiver’s frequency.
3. Remove the receiver’s antenna. Plug the BNC end of the 50 Ω test cable into the signal generator and the other end to the channel A antenna input.
4. Apply power to the LX4.
5. Verify that the unit unsquelches with rf signals greater than -89 dBm.
6. When the unit unsquelches, verify that the “Rf” LED glows.

Repeat this test for channel B.

Audio Tests

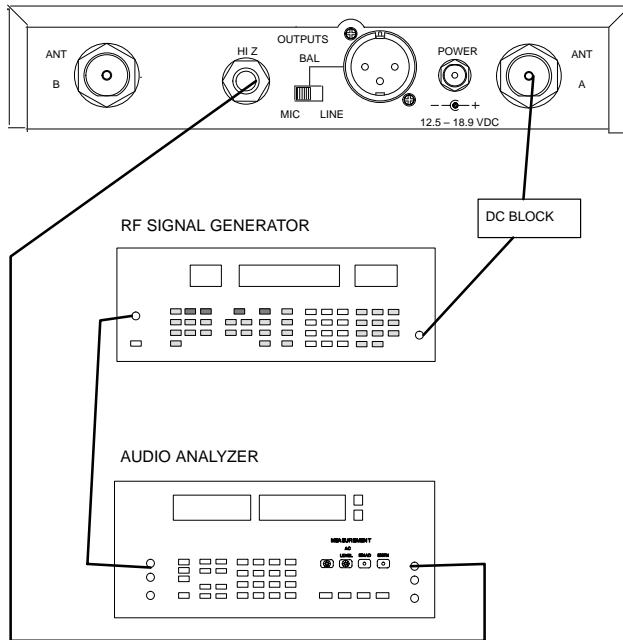

NOTE: DC VOLTAGES ARE PRESENT AT MOST RF TEST POINTS. USE A DC BLOCK ON THE RF SIGNAL GENERATOR TO PROTECT TEST EQUIPMENT.

LX4 Receiver		Audio Analyzer		Rf Signal Generator	
Power:	ON	Output amplitude:	Set to turn OFF high and low EXT lights on rf signal generator	Level:	- 60 dBm
Level (gain):	Max	Filters: 400 Hz High-Pass: ON 30 kHz Low-Pass: ON		Deviation:	15 kHz
Squelch:	Mid			Modulation:	EXT 1 kHz
				Frequency:	receiver frequency

Figure 3. Audio Test Set-Up, steps 1 – 5

Note: The amplitude may have to be adjusted so that neither the HI EXT nor the LO EXT LEDs on the rf signal generator are on. This amplitude should be between 1.4 and 1.5 V rms.

1. Set the rf signal generator level to -60 dBm, its deviation to 15 kHz, and its external modulation to 1 kHz.
2. Adjust the audio analyzer's output amplitude so that the high and low EXT lights on the rf signal generator are off.
3. Using a 3.3 kΩ load, connect the receiver's unbalanced audio output to the audio analyzer. The receiver's volume control should still be in its maximum position.
4. Engage the 400 Hz high-pass filter and the 30 kHz low-pass filter on the audio analyzer.
5. Verify the following receiver measurements:
 - Audio level is 400 mVrms, ± 90 mV. Record the measurement as a **reference level** for the following steps.
 - total harmonic distortion (THD) is <0.75%.

Shure LX4 Diversity Receiver

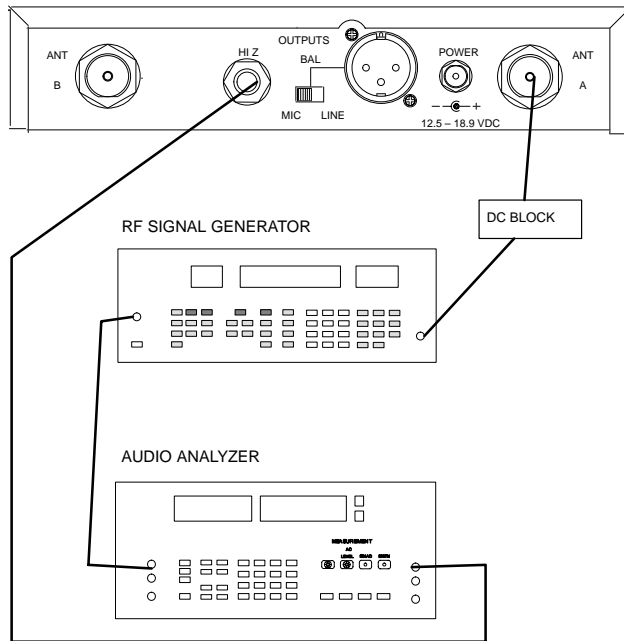

NOTE: DC VOLTAGES ARE PRESENT AT MOST RF TEST POINTS. USE A DC BLOCK ON THE RF SIGNAL GENERATOR TO PROTECT TEST EQUIPMENT.

LX4 Receiver		Audio Analyzer		Rf Signal Generator	
Power:	ON	Output amplitude:	Set to turn OFF high and low EXT lights on rf signal generator	Level:	- 60 dBm
Gain:	Max	Filters:		Deviation:	15 kHz
Squelch:	Mid	400 Hz High-Pass:	OFF	Modulation:	EXT 1 kHz
		30 kHz Low-Pass:	ON	Frequency:	Receiver frequency

Figure 4. Audio Functional Test Set-Up, steps 6 – 14

6. Use external modulation only on the rf signal generator. Input a 100 Hz signal from the audio analyzer to the external modulation input of the rf signal generator.
7. Disengage the 400 Hz high-pass filter on the audio analyzer.
8. Verify that the receiver's unbalanced audio output is within +2 dB, -1 dB of the reference level recorded in step 5.
9. Change the audio analyzer's frequency to 10 kHz.
10. Verify that the receiver's unbalanced audio output is -7.5 dB to -10.5 dB from the reference level recorded in step 5.
11. Place a 150 Ω load across the receiver's balanced output. Verify that it is in the MIC position.
12. Connect this output to the audio analyzer and select the float position. Verify that the output is 65 mVrms, \pm 15 mV.
13. Remove the 150 Ω load.
14. Take the audio analyzer input out of the float position.

Repeat this test for channel B.

After all testing has been completed, remove the test cable and reinstall the antenna. If the receiver passes these tests, the unit is functioning correctly and does not require alignment.

Disassembly and Assembly



! IMPORTANT SAFETY INSTRUCTIONS !

1. READ these instructions.
2. KEEP these instructions.
3. HEED all warnings.
4. FOLLOW all instructions.
5. DO NOT use this apparatus near water.
6. CLEAN ONLY with a damp cloth.
7. DO NOT block any of the ventilation openings. Install in accordance with the manufacturer's instructions.
8. DO NOT defeat the safety purpose of the grounding-type plug. The third prong is provided for your safety. When the provided plug does not fit into your outlet, consult an electrician for replacement of the obsolete outlet.
9. PROTECT the power cord from being walked on or pinched, particularly at plugs, convenience receptacles, and the point of exit from the apparatus.
10. USE only attachments/accessories specified by the manufacturer.
11. USE only with a cart, stand, tripod, bracket, or table specified by the manufacturer or sold with the apparatus. When a cart is used, use caution when moving the cart-apparatus combination to avoid injury from tip-over.
12. UNPLUG this apparatus during lightning storms or when unused for long periods of time.
13. REFER all servicing to qualified service personnel. Servicing is required when the apparatus has been damaged in any way, such as when the power-supply cord or plug has been damaged, liquid has been spilled or objects have fallen into the apparatus, the apparatus has been exposed to rain or moisture, does not operate normally, or has been dropped.



! CAUTION !

Observe precautions when handling this static-sensitive device.



! WARNING !

Voltages in this equipment are hazardous to life. No user-serviceable parts are inside. Refer all servicing to qualified service personnel. The safety certifications of the LX4 Diversity Receiver do not apply when the operating voltage is changed from the factory setting.

Disassembly

Remove the case:

1. Remove the six screws from the case top, which includes two screws on the top and two screws on either side.
2. Slide the case off the frame from front to back.

The front panel must be removed to access the printed circuit board:

3. Remove the clip from the center front panel frame screw tabs.
4. Unlock the four snap-in tabs to detach the front panel. Begin with the bottom two tabs, placing your fingers on the bottom of the chassis just behind each tab and squeezing down with your thumbs on the top of the front panel.
5. Next, release the two top tabs.

Remove the printed circuit board (pcb):

1. Remove the nuts and washers from the antenna input connectors and the HI-Z audio output connector.
2. Remove the two screws on either side of the balanced output XLR connector.
3. Unplug the dc power input from the pcb.
4. Remove the six screws anchoring the pcb to the bottom of the chassis.
5. Lift the pcb from the front and pull forward. Note the lock washers on the inside of the antenna connectors and HI-Z audio output connector.

Reassembly

Replace the printed circuit board:

1. Carefully replace the six screws that anchor the pcb to the bottom of the chassis and replug the dc power input to the pcb. Note the lock washers on the inside of the antenna connectors and HI-Z audio output connector.
2. Replace the two screws on either side of the balanced output XLR connector.
3. Replace the nuts and washers from the antenna input connectors and the HI-Z audio output connector.

Replace the front panel:

1. Slide the case on the frame from front to back.
2. Lock the four snap-in tabs to attach the front panel.
3. Replace the six screws from the case top (two screws on the top and two screws on each side).
4. Replace the clip from the center front panel frame screw tabs.

Notes:

Service Procedures

Test Equipment

Most test equipment needed is described in the Shure *Wireless Service Equipment Manual*. The following test equipment (or approved equivalent) is also needed.

Table 1
Test Equipment

Equipment Type	Model
Audio analyzer	*Hewlett-Packard 8903B
Digital multimeter	Fluke 87
Rf signal generator	Hewlett-Packard 8656B
Frequency counter	Hewlett-Packard 53181A
Spectrum analyzer	Hewlett-Packard 8590L

*Audio levels in dBu are marked as dBm on the HP8903B.

Changing the Frequency

System Operating Frequencies

The LX4 Diversity Receiver printed circuit board is marked with a group letter that identifies the range of frequencies the receiver can operate within.

The operating frequency may be changed to a different frequency within the same group. Before changing the operating frequency, refer to the Functional Test section and check the receiver for proper operation.

Change the frequency by changing the crystal on the rf board. For proper operation, the crystal must be obtained from Shure and must operate within the frequency range of the pc board. Use the following equation to determine the operating frequency:

$$\text{Carrier frequency} = 3 \times (\text{nominal crystal frequency in MHz}) + 10.71 \text{ MHz}$$

After the new crystal is installed, operational tests and alignment procedures must be performed to ensure that the receiver is operating correctly. The pcb label should also be updated to show the new frequency and letter identification code.

Table 2 Wireless Frequency Selections

Code	Frequency	Printed Circuit Board Assembly
A	169.445	T90_8632
	169.505	
	170.000	
	170.245	
	170.305	
	171.045	
	171.105	
	171.845	
	171.905	
173.800		
B	174.100	
	174.400	
	174.500	
	175.000	
	176.200	
	176.600	
	177.000	
C	177.600	
	180.400	
	182.000	
	182.200	
	183.200	
D	183.600	
	184.600	
	186.200	
	186.350	
	186.600	
E	189.000	
	190.600	
	191.900	
	192.200	
F	192.600	
	195.000	
	196.600	
	197.600	
G	198.600	
	200.300	
	200.350	
	201.650	
	202.200	
H	203.000	
	204.200	
	204.600	
	206.000	
	208.200	
J	208.300	
	209.000	
	216.100	
	216.300	
	217.000	
L	218.200	
	218.600	
	219.600	
	221.350	
L	232.825	
	233.125	
	234.625	
	237.325	

Alignment

The following steps are for channel A; channel B, is in parentheses. For example, TPA7 (TPB7) means to use TPA7 for channel A and TPB7 for channel B.

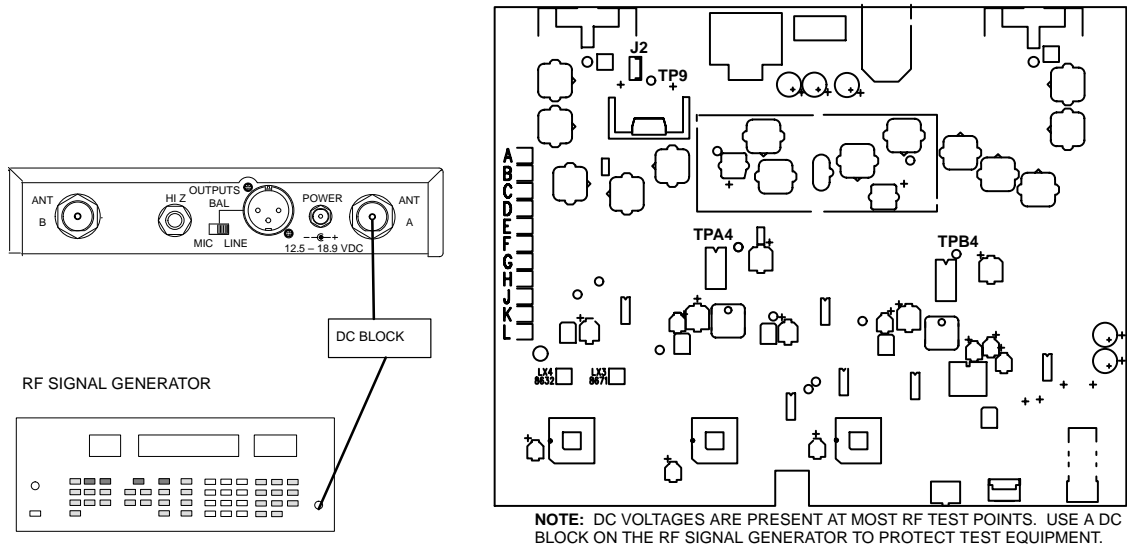

LX4 Receiver		Rf Signal Generator	
Power:	ON	Frequency:	carrier
Gain:	Max	Modulation:	OFF
Squelch:	Mid	Amplitude:	-60 dBm

Figure 3. Alignment Test Setup

1. Solder a 33 kΩ resistor between TPA4 (TPB4) and ground for rf adjustments. Do the same for channel B with TPB4.
2. Set the rf signal generator frequency to the same as the LX4, with no modulation, and its amplitude at -60 dBm.
3. Connect the power supply (PS40) to 120 Vac power and to the receiver's dc input connector (J2). The green power on LED of the LX4 should now be illuminated. If not, there is a circuit malfunction.
4. Connect the rf signal generator to the 50 Ω antenna input for channel A or channel B, as appropriate.
5. Verify that 10.0 ± 0.35 Vdc is present at TP9 (U7, pin 3), using a digital multimeter (DMM).

Preset the adjustable circuit components as follows:

6. Set volume (R32) control fully clockwise.
7. Set squelch (R66) control to midrange.
8. Turn the LX4 power OFF.

Received Signal Strength Indicator (RSSI) Adjustment

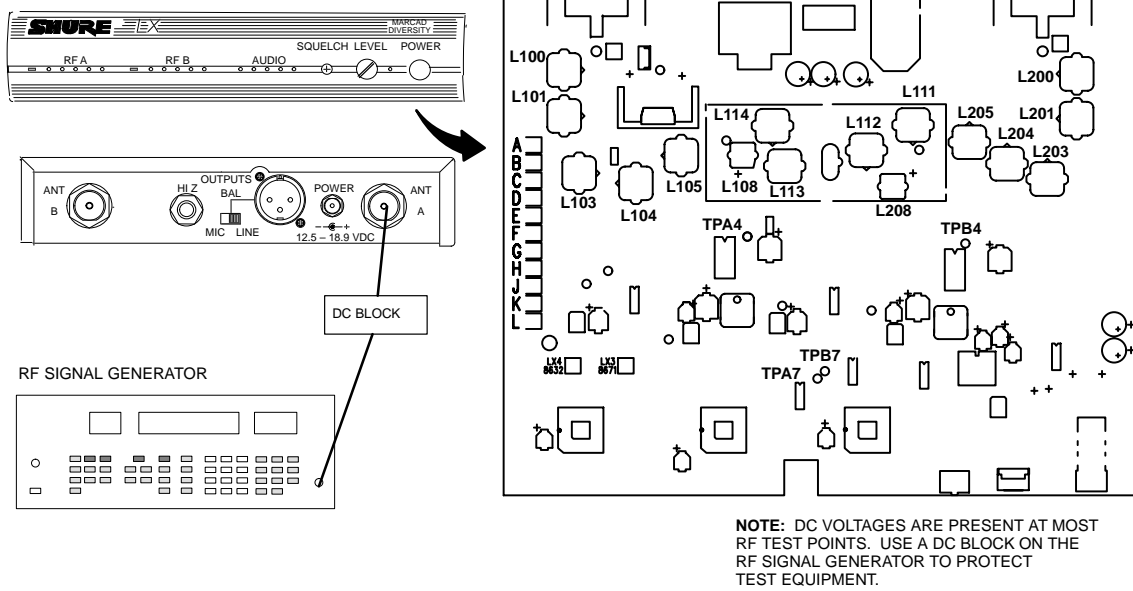

LX4 Receiver		Rf Signal Generator	
Power:	OFF	Frequency:	carrier
Gain:	Max	Modulation:	off
Squelch:	Mid	Mod source:	none
		Deviation:	none
		Amplitude:	off

Figure 4. RSSI Test Setup

1. Verify that the LX4 power is OFF.
2. Place a jumper between TPB7 and ground to mute channel B for channel A alignment. (Place a jumper between TPA7 and ground to mute channel A for channel B alignment.)
3. Turn the LX4 power ON.
4. Measure dc voltage at TPA4 (TPB4).
5. Adjust rf signal generator rf output so that approximately 2.0 Vdc is measured at TPA4 (TPB4).
6. If this is unattainable even with 0 dBm generator output, adjust L108 (L208) until the voltage is above 2.0 Vdc. If adjusting L108 (L208) does not produce more that 2.0 Vdc at TPA4, return it to the preset position and adjust L113 and L114 (L111, L112).
7. Adjust coils L100, L101, L103, L104, L105, L108, L113, and L114 (L200, L201, L203, L204, L205, L208, L111, and L112) for maximum voltage at TPA4 (TPB4). Use a hex-tuning wrench for all adjustments except L108 (L208), which requires a non-metallic screwdriver.
8. Reduce the rf signal generator output level as required to keep signal voltage under 3.0 Vdc.
9. Final adjustments should be performed with an rf signal generator output level of approximately -85 dBm.

Repeat this test for channel B.

Note: Inductance increases as the core is turned clockwise into the coil. The maximum inductance position is approximately two turns before full

Shure LX4 Diversity Receiver

clockwise rotation, or 13 mm (1/4-inch) below the top of the can. Minimum inductance occurs when the core is level with the top of the can.

Use care when turning the core to avoid locking it against the pcb and causing it to break. Should this happen, the core can be repaired either by removing the coil assembly and replacing it or by drilling out the core and inserting a new one, after removing any broken pieces that remain. Sometimes a broken core may be removed using a metallic Allen wrench of the correct size.

For coils other than L108 and L208, "sharpness" of tuning depends on the operating frequency within the frequency group. At the upper and lower edges of the group, a distinct peak may be difficult to observe. In this case, the core should be adjusted for maximum inductance and remain there. At frequencies near the high end of the group (where coils are adjusted to minimum inductance), **do not** back cores beyond the point where they are level with the top of the can. Only minimum change in inductance occurs beyond this point.

Audio Level Adjustments

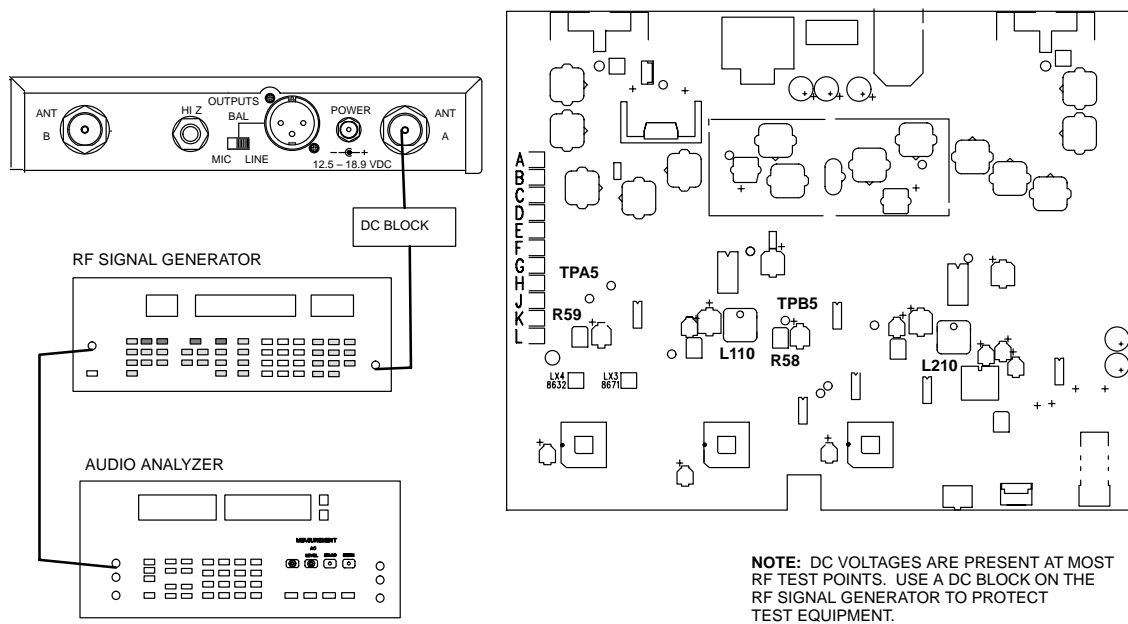

LX4 Receiver		Audio Analyzer		Rf Signal Generator	
Power:	ON	Output amplitude:	1.46 V rms	Frequency:	carrier
Gain:	Max	Frequency:	1 kHz	Modulation:	FM
Squelch:	Mid	Filters:		Mod source:	EXT
		400 Hz High-Pass:	ON	Amplitude:	-60 dBm
		30 kHz Low-Pass:	ON	Deviation:	15 kHz

Figure 5. Audio Level Adjustments Test Setup

Note: Remove the 33KΩ resistor from test point TPA4 and TPB4.

Note: The amplitude may have to be adjusted so that neither the HI EXT nor the LO EXT LEDs on the rf signal generator are on. This amplitude should be between 1.4 and 1.5 V rms.

Note: Place a jumper between TPB7 and ground to mute channel B for channel A alignment. (Place a jumper between TPA7 and ground to mute channel A for channel B alignment.)

1. Set the rf signal generator frequency to the same as the LX4, its modulation to FM, its modulation source to EXT, its FM deviation to 15 kHz, and its amplitude to -60 dBm.
2. Set the audio analyzer's audio frequency to 1 kHz and its amplitude to 1.46 V rms.
3. Connect the output of the audio analyzer to the input of the rf signal generator.
4. Place a probe on TPA5, U1, pin 1 (TPB5) and adjust L110 (L210) for maximum ac voltage.
5. With the probe still on TPA5 (TPB5), adjust R59 (R58) for 0.775 V ± 50 mV rms (1 kHz tone).

Repeat this test for channel B.

Noise Squelch Level Adjustment

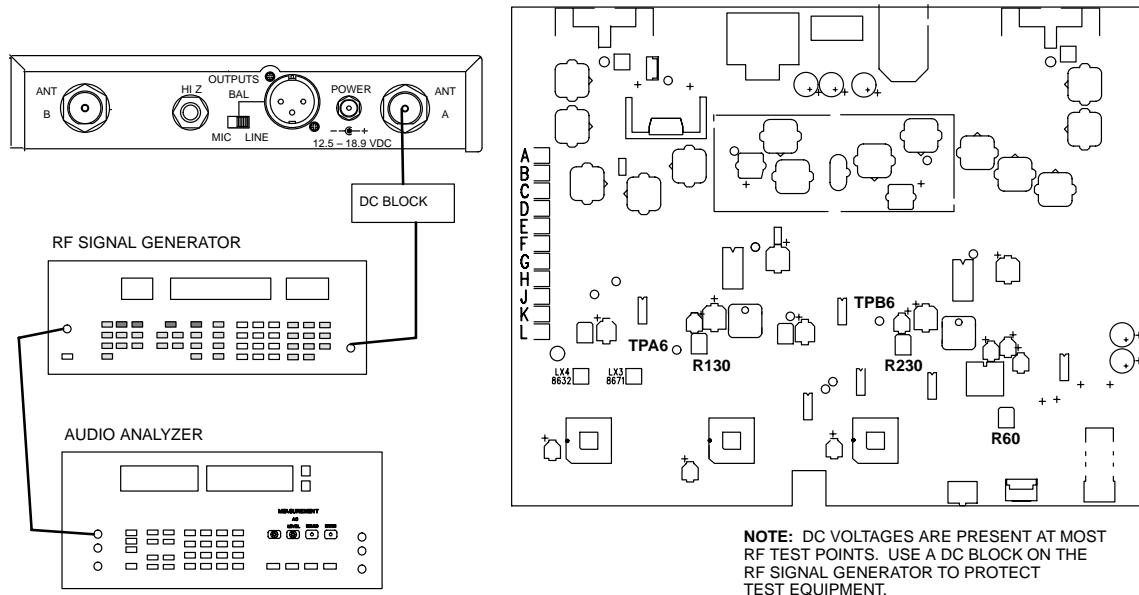

LX4 Receiver		Audio Analyzer		Rf Signal Generator	
Power:	ON	Output amplitude:	1.46 V rms	Frequency:	carrier
Gain:	Max	Frequency:	50 kHz	Modulation:	FM
Squelch:	Mid	Filters:		Mod source:	EXT
		400 Hz High-Pass:	ON	Amplitude:	-60 dBm
		30 kHz Low-Pass:	OFF	Deviation:	15 kHz

Figure 6. Noise Squelch Level Adjustment Test Setup

Note: The amplitude may have to be adjusted so that neither the HI EXT nor the LO EXT LEDs on the rf signal generator are on. This amplitude should be between 1.4 and 1.5 V rms.

1. Set the rf signal generator frequency to the same as the LX4, its modulation to FM, its modulation source to EXT, its FM deviation to 15 kHz, and its amplitude to -60 dBm.
 2. Set the audio analyzer's audio frequency to 50 kHz and its amplitude to 1.46 V rms. Disengage 30 kHz lowpass filter.
 3. Connect the output of the audio analyzer to the input of the rf signal generator's modulation input.
 4. For channel A, adjust R130 for 2.0 ± 0.05 Vdc at TPA6 (positive end of C18). For channel B, adjust R230 to $2.0 \pm .05$ Vdc at TPB6 (positive end of C17).
 5. Set the rf signal generator for 1 kHz modulation, amplitude to -50 dBm, with 15 kHz deviation. Engage 30 kHz lowpass filter.
 6. Measure total harmonic distortion (THD). Adjust R60 for minimum distortion at the unbalanced output. Distortion should be < .75%.
 7. Remove the external modulation from the rf signal generator.
- Repeat this test for channel B.

Squelch Adjustment Test

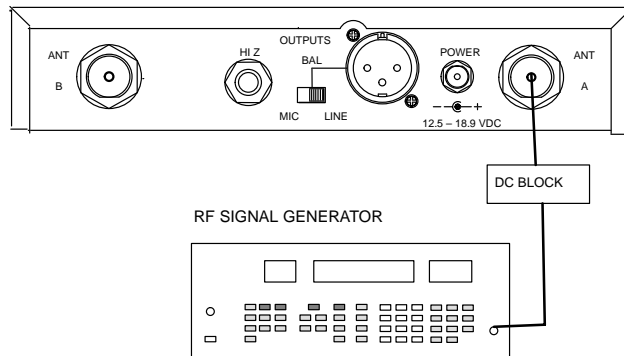

NOTE: DC VOLTAGES ARE PRESENT AT MOST RF TEST POINTS. USE A DC BLOCK ON THE RF SIGNAL GENERATOR TO PROTECT TEST EQUIPMENT.

LX4 Receiver		Rf Signal Generator	
Power:	on	Frequency:	carrier
Level (gain):	Max	Modulation:	FM
Squelch:	Mid	Mod source:	EXT
		Amplitude:	OFF
		Deviation:	15 kHz

Figure 7. Squelch Adjustment Test Setup

1. Remove the jumper between TPB7 (TPA7) and ground.
2. Set the rf signal generator output to minimum (or OFF).
3. Increase the output level until the appropriate diversity LED is illuminated. This should occur with an rf input level between -105 and -89 dBm (nominally, -100 dBm).

Repeat this test for channel B.

Notes:

Bench Checks

Power Input

- ✔ Make sure that 10.0 ± 0.35 Vdc is present at TP9 (U7, pin 3).
- ✔ If the voltage is lower than normal (but not zero), check for approximately 15 Vdc at the input of U7 (pin 1), a reversed electrolytic capacitor (C50), or a stage drawing excessive current.
- ✔ If the voltage is zero, check for solder bridges or shorted foil traces (defective pcb).
- ✔ If the voltage is higher than normal, or if other tests prove negative, replace U7.
- ✔ Make sure that 5.0 ± 0.25 Vdc is present at TP8 (U9, pin 7).

Audio

- ✔ If there is no audio at the output of the receiver, make sure that the channel is not squelched. Squelch may be defeated by rotating R130 (R230) counter-clockwise until the wipers are grounded.
- ✔ There should be 10 Vdc at TPA7 (TPB7), and the diversity A (B) LED should be on. If not, there is a problem in the squelch circuitry; see the “Muting” section.
- ✔ Check pin 8 of U100 (U200) for an audio signal of approximately -15 dBV. If there is no detected audio, check L110 (L210) and the components connected to pins 9–12 of U100 (U200); also check dc voltages at U100 (U200). Replace U100 (U200) if no other problem is found.
- ✔ If audio is present at pin 8 of U100 (U200), but not at the output of the receiver, trace the signal through signal amplifiers U1A (U2A) and expander U9 (05B).
- ✔ Use a 1 k series resistor at the test point when checking the audio at TPA5 (TPB5) to avoid loading the amplifier.
- ✔ Then check volume control R36 and the components going to audio output jacks J3, J1. If no signal is present at J1, the balanced LO-Z microphone level output, check U5C, U5D, and associated components. Check dc voltages on any stages that are not working properly; then look for wrong or missing components. Replace IC(s) only if no other problems are found.
- ✔ If the audio level cannot be set correctly with R59 (R58), make sure the other diversity channel is squelched. Only one channel should be activated during this adjustment.
- ✔ If the audio level is correct for the individual channels, but not when both are activated, check U6.
- ✔ If the audio level is correct, but the unit exhibits high THD, increment the rf input frequency 20 kHz above and below the operating frequency.
- ✔ If the THD drops to an acceptable level, check the local oscillator frequency. Also, check FL100, FL101, FL200, and FL201 for polarity.

- ✓ If the audio circuitry works correctly but the audio LEDs fail to light when the standard test signal is applied, or remain on when there is no modulation, check dc voltages at U11, and U4A.
- ✓ Check the audio LEDs. Replace any defective components.

Rf Problems

- ✓ Make sure that the rf test signal is being input to the correct diversity channel. If there is no deflection on the oscilloscope at TPA4 (TPB4) when the rf coils are adjusted, check the operation of the local oscillator.
- ✓ Turn off the rf generator and measure the injection level at TPA3 (TPB3) with a spectrum analyzer and FET probe. It should be approximately -15 to -20 dBm.
- ✓ If the level is correct, check the frequency of the local oscillator signal with the frequency counter. It should be 10.7 MHz below the operating frequency of the receiver, with a tolerance of $\pm .015$ MHz. For example, to receive 169.445 MHz, the local oscillator frequency would be 158.745 MHz, $\pm .015$ MHz.
- ✓ Crystal Y100 operates at one-third of this frequency, or 52.915 MHz. The nominal crystal frequency, which is stamped on the part, is 3.333 kHz lower, or 52.911667 MHz in this example. This is because the load reactance of the oscillator is not precisely zero.
- ✓ If any of the rf coils will not tune properly, see if the associated frequency-dependent capacitor(s) are missing or of the wrong value. If the IF coil will not tune, check C130 (C230).
- ✓ If all of the coils tune, but the rf signal level is low, check dc voltages and components at rf amplifier Q100 (Q200).
- ✓ If everything is working correctly, the dc voltage at TPA4 (TPB4) will be between 1.0 and 2.0 Vdc with a -95 dBm rf input signal, depending on component parameters and receiver frequency.

Muting

- ✓ With TPA7 (TPB7) connected to ground, the appropriate diversity channel should be squelched and the diversity A (B) LED should be off, regardless of the presence or absence of an rf input signal in that channel. If not, check dc voltages at U3, U1, U6, and U2. Investigate any irregularities. Replace any components that are found to be defective.
- ✓ If the squelch circuit works but has insufficient adjustment range, check for low voltage at TPA4 (TPB4) with a -100 dBm rf input signal.
- ✓ Low rf levels at the input of U100 (U200) will cause inadequate noise at the output of U1C (U2C). In order for the noise squelch circuits to function, the detector portions of U100 (U200) must also be functioning correctly.
- ✓ Also check the dc voltages and component values of noise amplifiers U1B (U2B) and high-pass filters U1C (U2C), if necessary.

Replacement Parts and Drawings

Parts Designations

The following comments apply to the parts list and the schematic:

Resistors: All resistors are surface-mount with $1/10$ W rating and 1% tolerance.

Capacitors: Unless otherwise noted, non-polarized capacitors are surface-mount NPO dielectric types with a 100 V capacity and a 5% tolerance, and polarized capacitors are tantalum types.

Table 3
Replacement Parts

Reference Designation	Description	Shure Part Number
A1	Printed circuit board assembly	90_8632K [See Table 1, p. 12, to determine the GROUP CODE in the underlined space. e.g. 90 <u>A</u> 8632K].
A2	Cable, Connector Assy, DC Jack	90B8688
A3	Front Panel/Light Pipe Assy.	90A8633
A4	Knob Assembly, (volume)	65D8249A
E1	Whip Antenna	90A8380 for 169–186MHz 90B8380 for 186–204MHz 90C8380 for 204–240MHz
E2	Mounting Bracket (short)	53A8350
E3	Mounting Bracket (long)	53A8381
E4	Link Bar	31A8138
K1	Hardware Kit	90TZ1371
	Screw, Sems, Head, Round (linking units)	30J622E
	Screw, Machine, Head, Pan (mount units)	30F8060B
	Screwdriver	80A498
	Washer, Panel, Nylon, Black	65A8234
	Bumper, Round, Black	66A8010
	Plug, Hole, Black	66B8041
MP1	Knob (power)	65B8250
MP2	Nut, Hex, .8mm (power connector)	95Z8562

MP3	Washer (power connector)	95Y8562
MP4	Nut, Hex, Black, 3/8–32 (1/4" jack)	30A884A
MP5	Washer, Black (1/4" jack)	30A961B
MP6	Lockwasher, Tooth, Internal, 3/8 (1/4" jack)	30P631A
MP7	Washer (antenna jack)	30A8154A
MP8	Nut, Hex, 5/8–24 (antenna jack)	95Z8414
MP9	Lockwasher, Tooth, Internal, 5/16 (antenna jack)	30R631A
MP10	Nut, Hex, M7x.75 (volume pot.)	30A8049A
MP11	Washer, Aluminum (volume pot.)	30A8052
MP12	Screw, Sems, Head, Round (PCB)	30C622B
MP13	Screw, Sems, Head, Pan, Black (top cover)	30E925D
MP14	Screw, Sems, Head, Pan, Black (XLR)	30D8178B
MP15	Fastener, U Type (case top)	47A108
MP16	Connector Bracket	53A8367
MP17	Top Cover, Steel	53A8410
MP18	Chassis, Steel	53A8409
MP19	Nameplate, Rear	39A8409
Y100	Crystal	40_8003A [See Table 1, p. 12 to determine the crystal code in the underlined space. e.g. 40CL8003A].

*Table 4
Printed Circuit Board Parts*

C37,41,42,61,62	Capacitor, Electrolytic, 47uF, 63V, 20%	86BE629
C50,135,235	Capacitor, Electrolytic, SMD, 100uF, 16V, 20%	151DB107MD
C3,4,49,52,136,236	Capacitor, Electrolytic, SMD, 10uF, 35V, 20%	151BF106MC
C31,33,39,53,54,57,127,227	Capacitor, Electrolytic, SMD, 4.7uF, 35V, 20%	151BF475MB
C17,18,30,32,46	Capacitor, Electrolytic, SMD, 1uF, 50V, 10%	151BG105KB
D1,2,3,4,5,6	Switching Diode SOT–23, 100VDC (MMBD7000L)	184A08
D7,8	Rectifier, Silicon, 140VDC	184A20

Shure LX4 Diversity Receiver

D9,10,18	LED, Surface Mount, Orange	184E18
D11,12,13,14,15,16, 19,20,21,22,23,24,25, 26	LED, Surface Mount, Green	184D18
D17	LED, Surface Mount, Red	184A18
FL100,101,200,201	Filter, Ceramic, 10.7MHz	86A8910
J1	XLR Connector (Male)	95A8598
J2	Shroud Header, 2 Position	95A8272
J3	1/4 Inch Phone Jack	95A8104
J100,200	Antenna Connector	95X8414
L1,2,4,5,102,106,107, 109,116,202,206,207, 209,216	Bead, Ferrite, SMD1206, 65 OHM	162A03
L100,101,104,105,112 ,113,200,201,204,205	Coil, Tunable, MC-120, 45nH	82A8003
L108,208	Coil, Tunable, 4.7uH	82A8005
L110,210	Quadrature Coil, 10.7MHz	82A8004
L111,114	Coil, Tunable, MC-120, 47nH	82B8003
L115	Inductor, SMD1008, .22uH	162C06
Q1	Transistor, Low Noise, SOT-23, NPN (MMBT5089L)	183A38
Q100,101,200,201	Amp., 2 Gate, Hi Gain, LO Noise, SOT143 (NE25139)	183A12
Q102,103,104,202	Transistor, RF, SOT-23, NPN (BF840)	183A14
R32	Potentiometer, 10K (volume)	46A8032
R58,59,60,130,230	Potentiometer, Trim, SMD, 5K	146D02
R66	Potentiometer, 100K (squelch)	46B8055
S1	Switch, Slide, Right Angle, DPDT (Mic/Line)	55A8061
S2	Switch, Push Button, Right Angle, DPDT (Power)	55B8062
U1,2	Quad Op Amp (MC33179D)	188A49
U3,4	Comparator, Quad, Low Power, SO-14 (LP339M)	188A123
U5	Quad Op Amp, SO-14 (TLC2274CD)	188A150
U6	Switch, Multiplexer, Quad, SO-14, (HEF4066BTD)	188A19
U7	Voltage regulator (LM2940T)	86A8918
U9	Compandor, SOL-16 (SA571D)	188A01
U10,11,12	Driver, Display, Dot/Bar, PCC-20 (LM3914V)	188A86
U100,200	FM Detector (LA1145M)	188A129

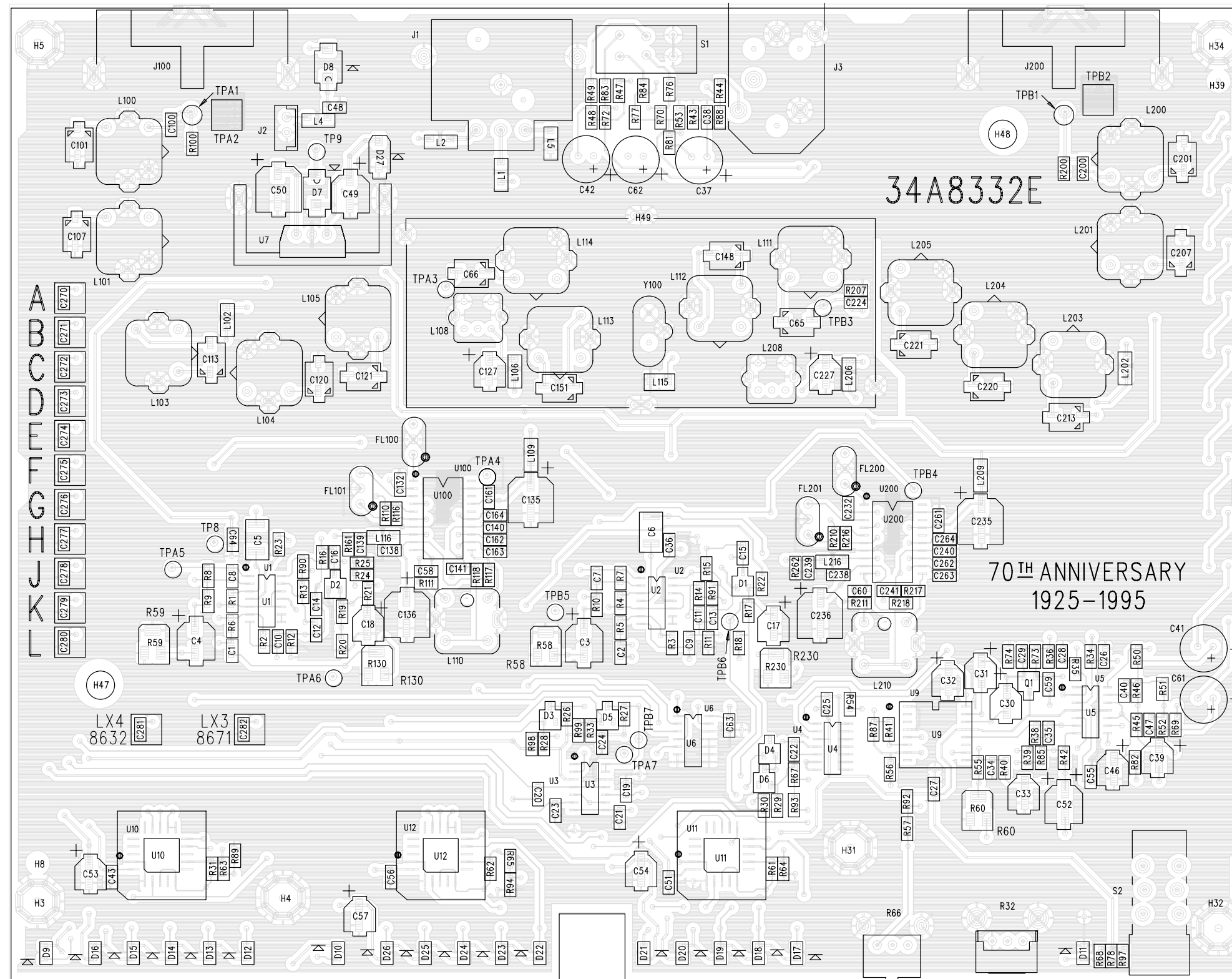

LX4 Diversity Receiver: Printed Circuit Board Top View

Printed in U.S.A.

Shure LX4 Diversity Receiver

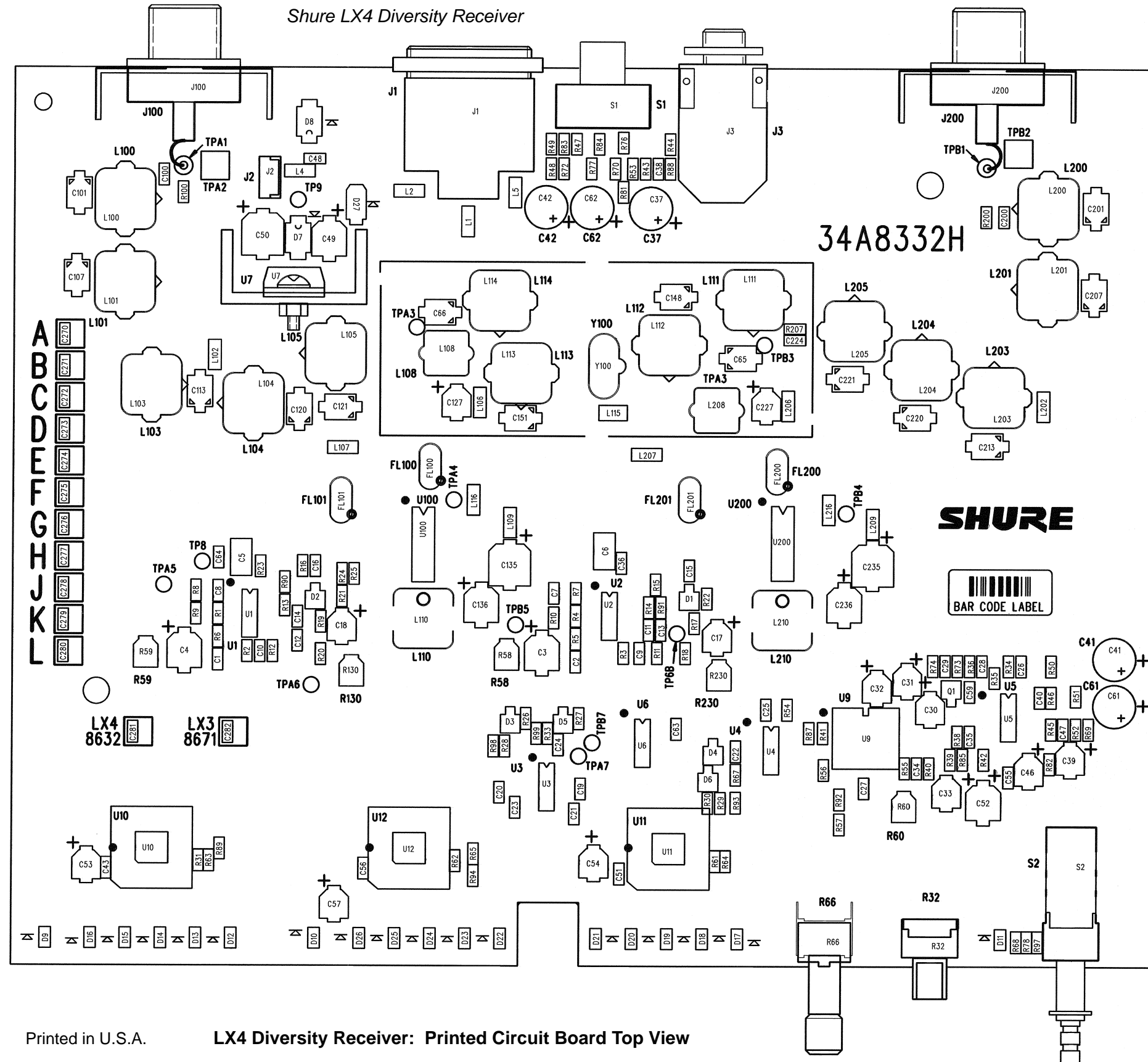

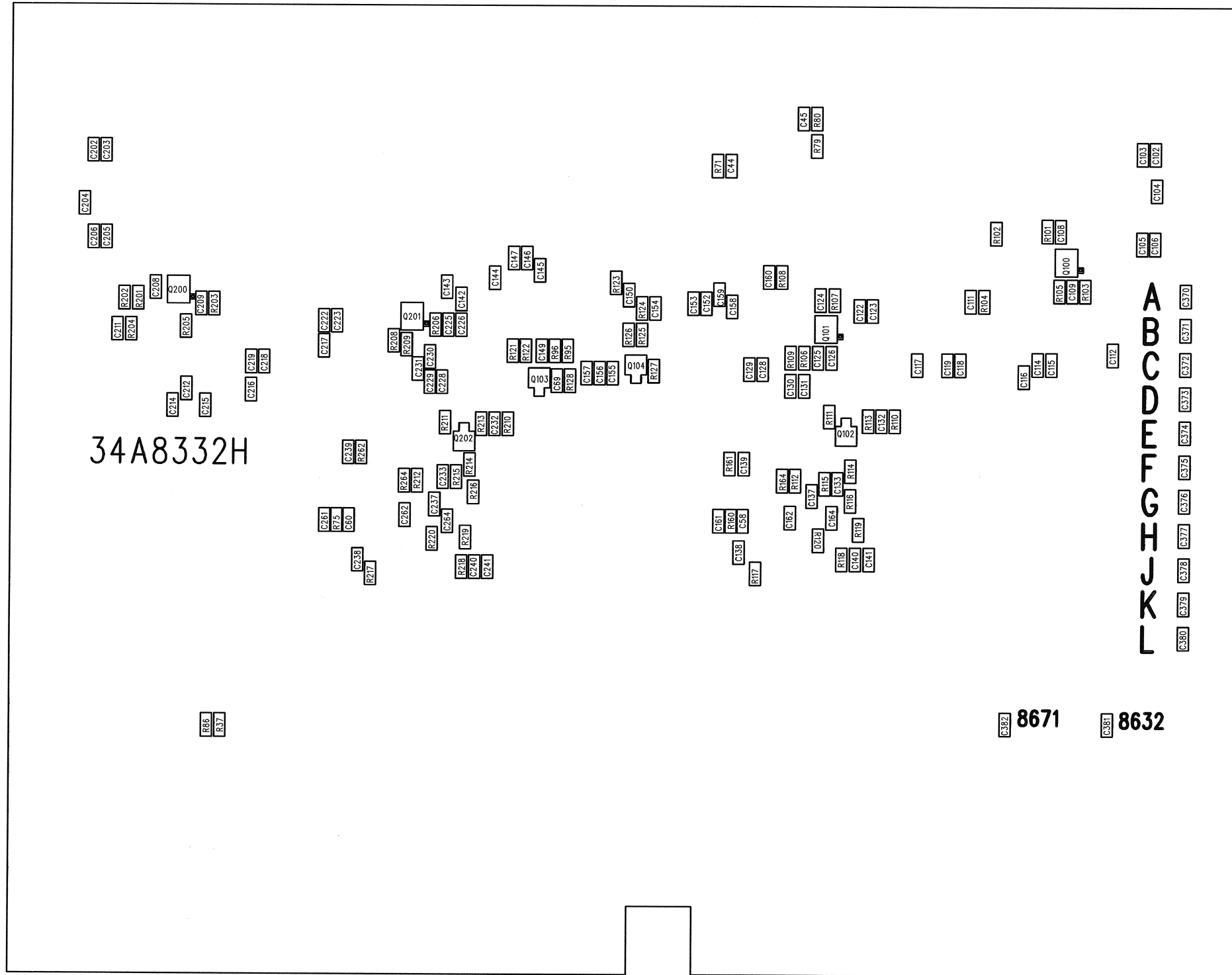

Shure LX4 Diversity Receiver

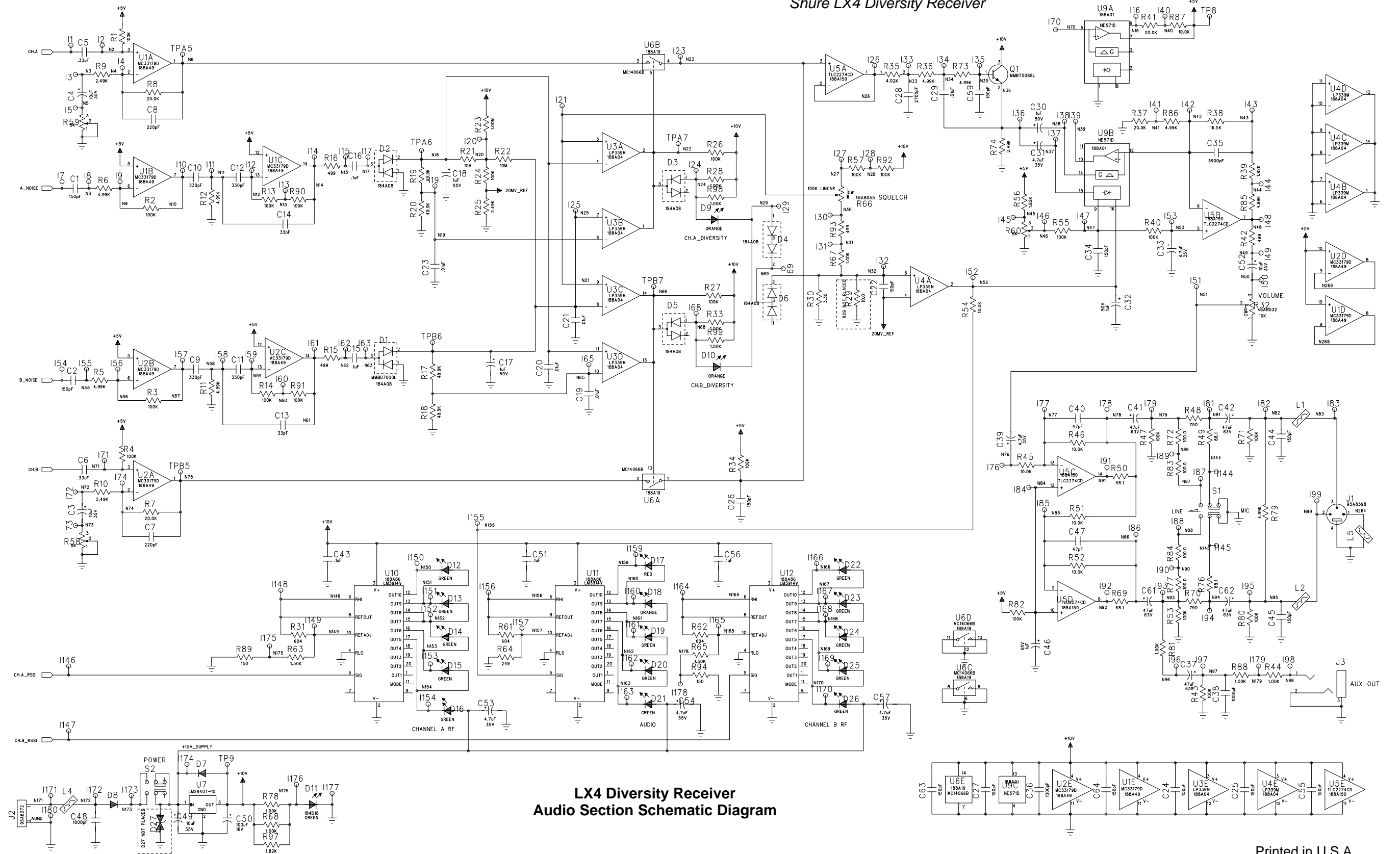

LX4 Diversity Receiver
Audio Section Schematic Diagram

Shure LX4 Diversity Receiver

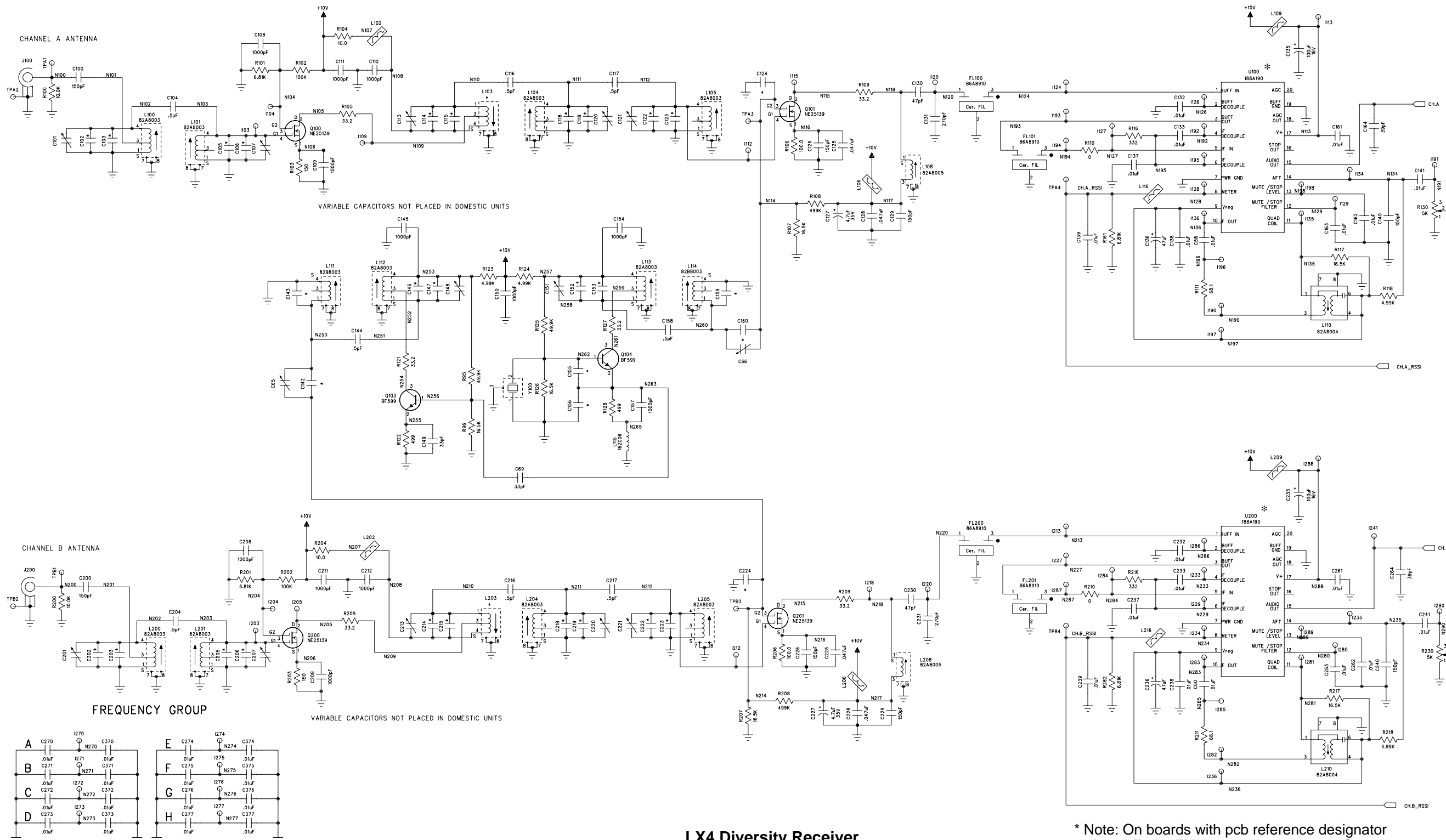

LX4 Diversity Receiver
Rf Section Schematic Diagram

* Note: On boards with pcb reference designator 34A8332E, the FM detector is 188A190. On other boards, it is 188A129.

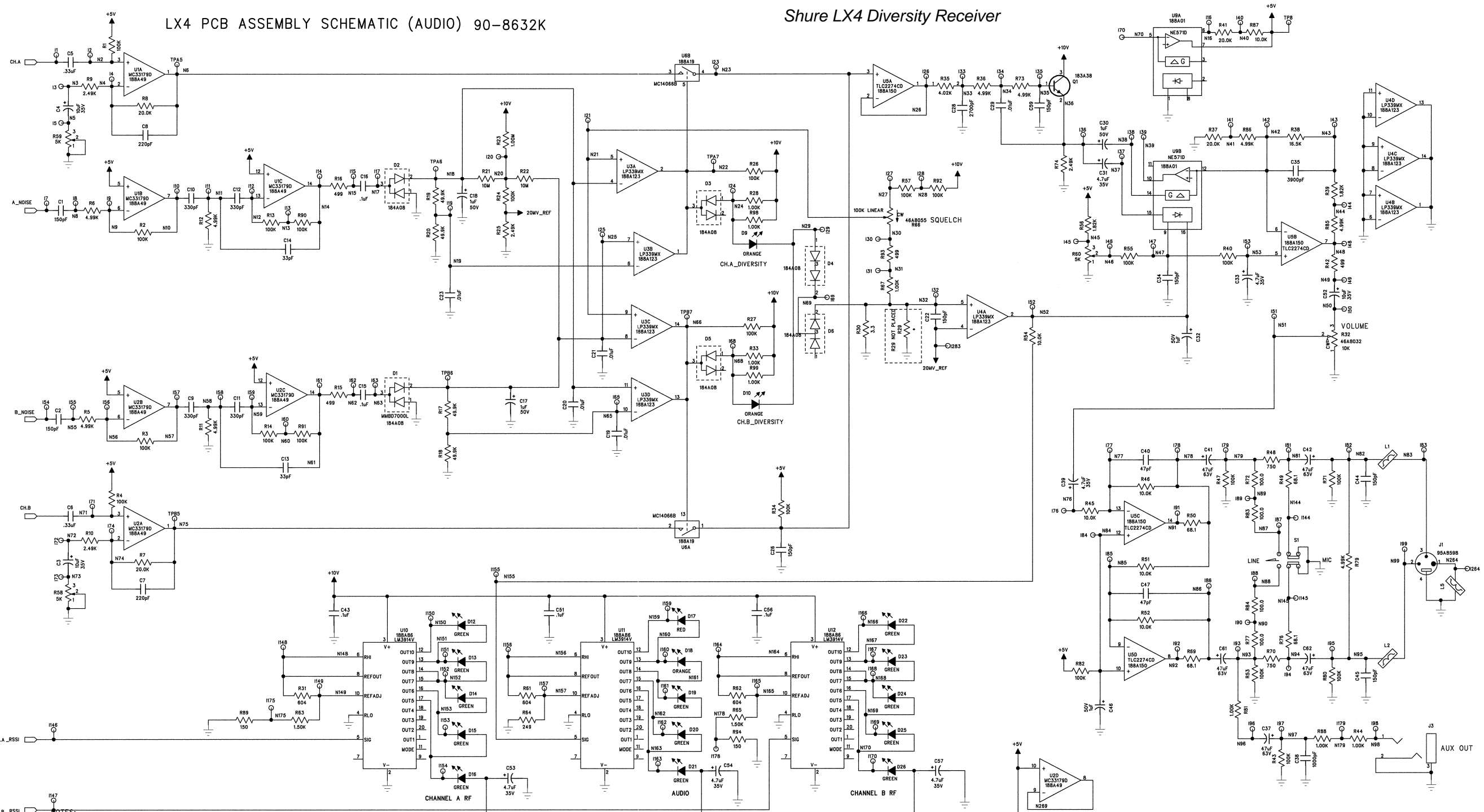

Shure LX4 Diversity Receiver

LX4 Diversity Receiver Audio Section Schematic Diagram

- NOTES:
1. All resistors 1/10 Watt, 1%, 0805 unless otherwise specified.
 2. Electrolytic capacitors shown in uF x Volts. All non-polar capacitors in uF, tolerance 10% and 50V or more unless otherwise specified.
 3. The following symbols denote:
 - 150V A.C. Voltage
 - 150V D.C. Voltage
 - P.C. ground
 - Case ground

NOTE: X,Y SCALE CORRESPONDES TO THE X,Y COORDINATES IN SCHEMATIC CAPTURE.

AUDIO

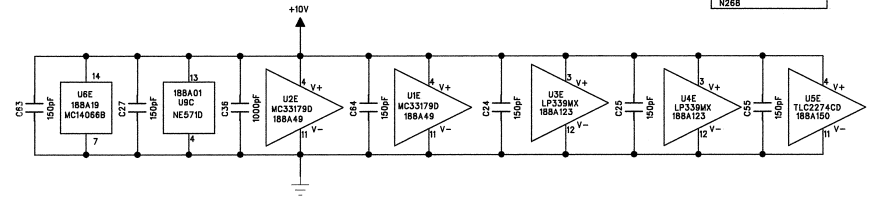

Shure LX4 Diversity Receiver

RF SECTION 90-8632K

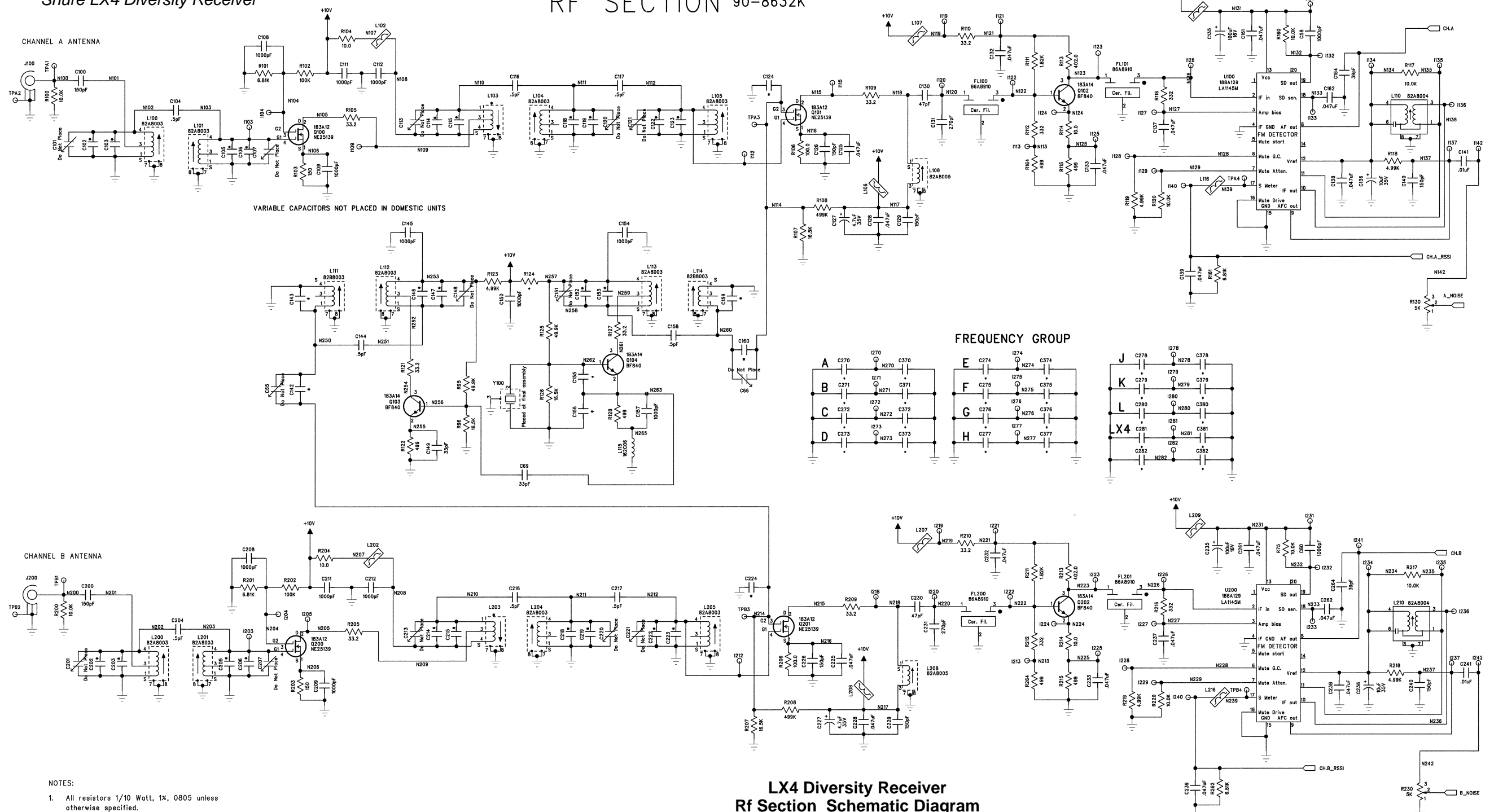

- NOTES:
- All resistors 1/10 Watt, 1%, 0805 unless otherwise specified.
 - Electrolytic capacitors shown in uF x Volts. All non-polar capacitors in uF, tolerance 10% and 50V or more unless otherwise specified.
 - The following symbols denote:
 - A.C. Voltage
 - D.C. Voltage
 - P.C. ground
 - Case ground

X,Y SCALE CORRESPONDES TO THE X,Y COORDINATES IN SCHEMATIC CAPTURE.

ASSEMBLY #	R124	L103, L203	C102	C103	C105	C106	C114	C115	C118	C119	C122	C123	C124	C142	C143	C146	C147	C152	C153	C155	C156	C159	C160	C202	C203	C205	C206	C214	C215	C218	C219	C222	C223	C224
90A8671	4.99K	82B8003	1pF	15pF	12pF	1pF	1pF	12pF	12pF	2.2pF	2.2pF	12pF	33pF	33pF	N/A	12pF	2.2pF	N/A	15pF	20pF	47pF	N/A	33pF	1pF	15pF	12pF	1pF	1pF	10pF	12pF	2.2pF	2.2pF	12pF	33pF
90B8671	4.99K	82B8003	N/A	15pF	12pF	1pF	N/A	12pF	12pF	2.2pF	1pF	12pF	27pF	27pF	1pF	12pF	N/A	N/A	15pF	20pF	47pF	1pF	27pF	N/A	15pF	12pF	1pF	N/A	10pF	12pF	2.2pF	1pF	12pF	27pF
90C8671	4.99K	82B8003	2.2pF	12pF	12pF	N/A	N/A	12pF	12pF	1pF	N/A	12pF	10pF	10pF	12pF	N/A	12pF	3.3pF	10pF	27pF	47pF	2.2pF	27pF	N/A	12pF	12pF	1pF	1pF	8.2pF	12pF	N/A	12pF	27pF	
90D8671	4.99K	82B8003	3.3pF	10pF	10pF	N/A	1pF	10pF	10pF	1pF	1pF	10pF	22pF	22pF	2.2pF	10pF	1pF	3.3pF	10pF	27pF	47pF	2.2pF	27pF	3.3pF	10pF	10pF	N/A	N/A	8.2pF	12pF	1pF	10pF	22pF	
90E8671	4.99K	82C8003	N/A	12pF	10pF	N/A	N/A	10pF	22pF	1pF	10pF	22pF	1pF	10pF	3.3pF	10pF	10pF	10pF	27pF	39pF	10pF	22pF	N/A	12pF	10pF	N/A	1pF	15pF	10pF	1pF	10pF	22pF		
90F8671	4.99K	82C8003	1pF	10pF	8.2pF	1pF	1pF	20pF	10pF	1pF	8.2pF	20pF	20pF	N/A	8.2pF	N/A	10pF	10pF	27pF	39pF	N/A	20pF	1pF	10pF	8.2pF	1pF	1pF	15pF	10pF	1pF	8.2pF	20pF		
90G8671	4.99K	82C8003	N/A	10pF	8.2pF	N/A	1pF	18pF	8.2pF	1pF	18pF	18pF	N/A	6.8pF	5pF	1pF	10pF	10pF	27pF	39pF	N/A	10pF	1pF	10pF	8.2pF	N/A	N/A	15pF	1pF	8.2pF	18pF	18pF		
90H8671	4.99K	82C8003	1pF	8.2pF	6.8pF	5pF	2.2pF	15pF	8.2pF	N/A	8.2pF	15pF	15pF	5pF	6.8pF	1pF	N/A	8.2pF	20pF	33pF	N/A	15pF	1pF	8.2pF	6.8pF	.5pF	1pF	12pF	8.2pF	N/A	N/A	8.2pF	15pF	
90I8671	2.21K	82C8003	1pF	8.2pF	6.8pF	N/A	N/A	15pF	6.8pF	N/A	6.8pF	15pF	15pF	N/A	6.8pF	N/A	8.2pF	15pF	33pF	33pF	N/A	15pF	1pF	8.2pF	6.8pF	N/A	1pF	12pF	6.8pF	N/A	N/A	6.8pF	15pF	
90K8671	2.21K	82C8003	N/A	8.2pF	5.6pF	5pF	1.8pF	12pF	5.6pF	1pF	.5pF	5.6pF	12pF	12pF	1pF	5.6pF	5pF	5pF	6.8pF	15pF	27pF	1pF	12pF	N/A	8.2pF	5.6pF	.5pF	N/A	12pF	6.8pF	N/A	5pF	5.6pF	12pF
90L8671	2.21K	82C8003	.5pF	6.8pF	5.6pF	N/A	1pF	12pF	5.6pF	N/A	N/A	5.6pF	12pF	12pF	N/A	4.7pF	N/A	N/A	6.8pF	15pF	27pF	N/A	12pF	.5pF	6.8pF	5.6pF	N/A	N/A	10pF	5.6pF	N/A	5.6pF	12pF	