



SR105 Power Amplifier  
**OPERATION AND SERVICE MANUAL**

**Manufactured by  
SHURE BROTHERS INC.  
222 Hartrey Avenue  
Evanston, Illinois 60204 U.S.A.**

**WARNING**

To reduce the risk of fire or electric shock, do not expose this appliance to rain or extreme moisture.

# SR105 Power Amplifier

## SPECIFICATIONS

The following specifications apply to both SR105A and SR105B Power Amplifiers except where noted. The SR105A Power Amplifier provides both direct-coupled speaker output and transformer-coupled, constant-voltage, 70-volt output. The SR105B Power Amplifier is equipped for direct-coupled speaker output only.

|                           |   |                    |  |
|---------------------------|---|--------------------|--|
| Amplifier Type            | All silicon transistor power amplifier  | Load Regulation:   |  |
| Power Output              | 200 watts rms continuous to 4-ohm load<br>100 watts rms continuous to 8-ohm load<br>150 watts rms continuous to 70-volt line (33-ohm load)* | Direct-Coupled     |  |
| Voltage Gain              | 27 $\pm$ 2 dB (4-ohm load at 1 kHz)<br>35 $\pm$ 3.5 dB (33-ohm load at 1 kHz across 70-volt output)*  | Speaker Output     | Less than 1 dB from no-load to 4-ohm load at 200 watts rms output  |
| Sensitivity               | 1.2 volts nominal (full rated output)   | 70-Volt Output*    | Less than 2 dB from no-load to 33-ohm load at 150 watts rms output   |
| Frequency Response        | $\pm$ 1.5 dB, 20-20,000 Hz (typical)<br>$\pm$ 2 dB, 50-15,000 Hz (typical, 70-volt output)*   | Phasing            | Pin 3 and phone jack tips of inputs in phase with speaker output phone jack tips, and 28V and 70V terminals  |
| Input Impedance           | 39 kilohms $\pm$ 30%, balanced or unbalanced*<br>25 kilohms $\pm$ 30%, balanced or unbalanced**   | Power Supply       | 120 volts, 50/60 Hz ac only. Power consumption: 40 watts max. (20 watts typical) with no signal, 450 watts with 1 kHz signal and 200 watts output; 500 watts maximum |
| Total Harmonic Distortion | 2% max. at 1 kHz, 200W (4-ohm load, 28.3 Vrms output)<br>3% max. at 1 kHz, 150W (33-ohm load, 70.7 Vrms output)*                            | Temperature Range: |  |
| Hum and Noise             | 80 dB below rated output (less than 2.8 mV at direct-coupled speaker output with Volume Control at 0)                                       | Operating          | -7° to 43°C (20° to 110°F)   |
| Output Clipping Level     | 28.3 Vrms min. at 1 kHz (4-ohm load)  | Storage            | -34° to 74°C (-30° to 165°F)   |
| Load Impedance:           |   | Dimensions         | 178 mm x 483 mm x 270 mm<br>(7 in. H x 19 in. W x 10 $\frac{5}{8}$ in. D)  |
| Direct-Coupled            |   | Weight:            |  |
| Speaker Output            | 4 ohms or greater (4 ohms min.)   | SR105A             | 15.66 kg (34 lb 8 oz)  |
| 70-Volt Output*           | 150 watts max. (33 ohms min.)   | SR105B             | 12.23 kg (27 lb)   |
|                           |   | Finish             | Matte black  |
|                           |   | Installation       | Equipped for standard 19" (483 mm) rack mounting; may be operated in optional A105A Carrying Case  |
|                           |   | Certifications     | Listed by Underwriters' Laboratories, Inc.; listed by Canadian Standards Association as certified  |

\* Model SR105A only.  
\*\* Model SR105B only.

# SR105 Power Amplifier

## SPECIFICATIONS

(Curves shown are typical)

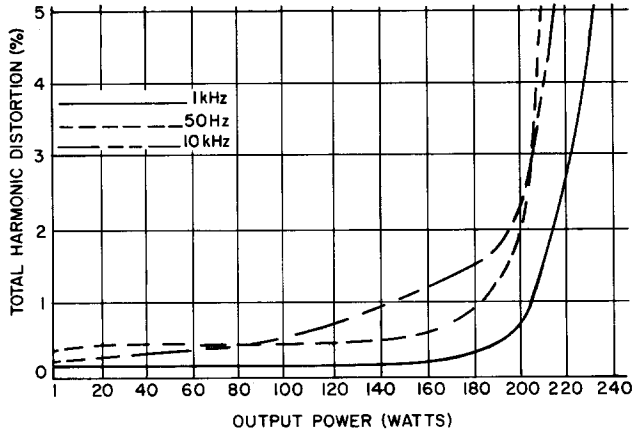

**TOTAL HARMONIC DISTORTION VS. OUTPUT POWER TO 4-OHM LOAD AT 50 HZ, 1 KHZ & 10 KHZ (DIRECT OUTPUT ONLY)**

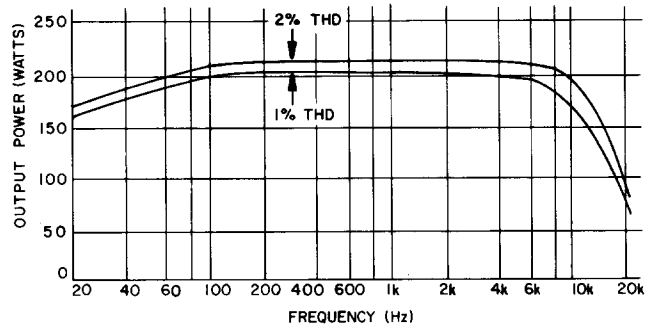

**OUTPUT POWER VS. FREQUENCY AT 1% & 2% TOTAL HARMONIC DISTORTION TO 4-OHM LOAD (DIRECT OUTPUT ONLY)**

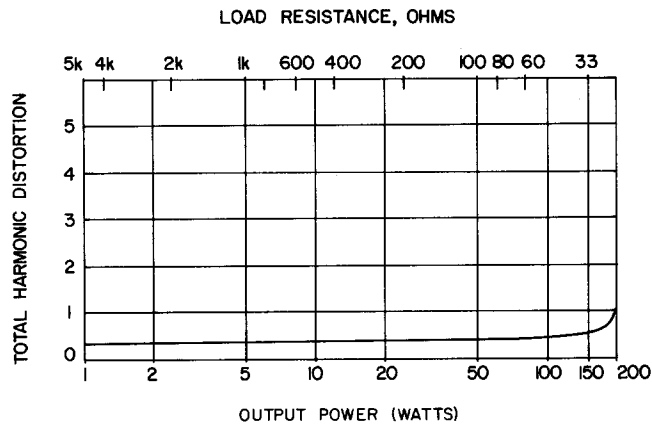

**TOTAL HARMONIC DISTORTION VS. OUTPUT POWER (VARIOUS LOADS) AT 1 KHZ AND CONSTANT 70.7V OUTPUT (70V OUTPUT ONLY)\***

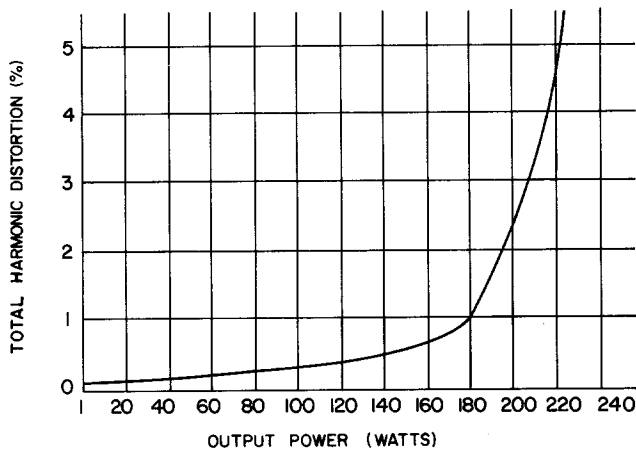

**TOTAL HARMONIC DISTORTION VS. OUTPUT POWER TO 150-WATT (33-OHM) LOAD AT 1 KHZ FOR INCREASING OUTPUT VOLTAGES (70V OUTPUT ONLY)\***

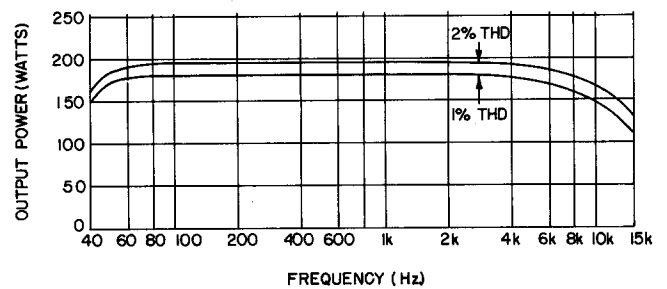

**OUTPUT POWER VS. FREQUENCY AT 1% & 2% TOTAL HARMONIC DISTORTION TO 33-OHM LOAD (70V OUTPUT ONLY)\***

\*Model SR105A only.



# SR105 Power Amplifier

## TABLE OF CONTENTS

| Section  | Page | Section  | Page |
|--|------|--|------|
| SPECIFICATIONS .....                               | ii   | Replacement Parts .....                              | 12   |
| DESCRIPTION .....                                  | 1    | Fuse Replacement .....                               | 12   |
| OPERATING INSTRUCTIONS                             |      | Bottom Plate Removal .....                           | 12   |
| Functional Identification .....                    | 3    | Cover Removal .....                                  | 12   |
| General Operating Instructions .....               | 3    | Lamp Replacement .....                               | 12   |
| Mounting and Ventilation .....                     | 4    | Dc Output Balance Adjustment .....                   | 12   |
| Thermal Overload .....                             | 4    | Output Voltage Meter Calibration .....               | 12   |
| Power Requirements .....                           | 4    | Printed Circuit Board Removal .....                  | 13   |
| Functional Circuit Description .....               | 4    | Small Signal and Predriver Transistors .....         | 14   |
| Input Connections .....                            | 4    | Driver Transistors .....                             | 14   |
| Output Connections .....                           | 6    | Output Transistors .....                             | 15   |
| Amplifier-to-Speaker Impedance Matching .....      | 8    | Diodes .....   | 15   |
| Output Voltage Meter .....                         | 9    | Diode Bridge Rectifier .....                         | 15   |
| Basic Operating Hints .....                        | 10   | Checking Transistors and Diodes .....                | 15   |
| SPECIAL OPERATING INSTRUCTIONS                     |      | SR105B Amplifier Conversion for 70-Volt Output ..... | 15   |
| Adding SR105A Amplifiers in a                      |      | Service Illustrations .....                          | 17   |
| 70-Volt System (Cascaded) .....                    | 10   | Guarantee .....                                      | 17   |
| Bridging Connections .....                         | 11   | Shipping Instructions .....                          | 17   |
| Adding Headphone Jack to Speaker Connections ..... | 11   | PARTS LIST .....                                     | 19   |
| SERVICE INSTRUCTIONS                               |      | CONDENSED OPERATING INSTRUCTIONS .....               | 27   |
| Amplifier Service .....                            | 12   | ARCHITECTS' AND                                      |      |
|  |      | ENGINEERS' SPECIFICATIONS .....                      | 27   |

# SR105 Power Amplifier

## LIST OF ILLUSTRATIONS

| Figure  | Page | Figure   | Page |
|---|------|--|------|
| 1 SR105 Power Amplifier Front Panel .....     | 2    | 10 70-Volt System Attenuator .....                   | 11   |
| 2 SR105 Power Amplifier Rear Panel .....      | 2    | 11 Bridged Amplifier Connections .....               | 11   |
| 3 SR105 Power Amplifier Dimensional           |      | 12 Headphone Jack for Speaker Connections .....      | 11   |
| Outline Drawing .....                         | 4    | 13 SR105 Power Amplifier Top View, Cover             |      |
| 4 SR105 Power Amplifier Block Diagram .....   | 5    | Removed (SR105A Model Shown) .....                   | 13   |
| 5 Input Connections .....                     | 6    | 14 SR105 Power Amplifier Bottom View,                |      |
| 6 Output Power vs. Load Impedance from        |      | Cover Removed (SR105A Model Shown) .....             | 14   |
| 2 Ohms to 32 Ohms .....                       | 7    | 15 70-Volt Conversion: Added Circuitry .....         | 16   |
| 7 70-Volt Output Power vs. Direct Output Load |      | 16 70-Volt Conversion: Transformer Mounting .....    | 17   |
| Impedance from 4 Ohms to 100 Ohms .....       | 7    | 17 70-Volt Conversion: Internal Wiring .....         | 18   |
| 8 Recommended Wire Gauge vs. Amplifier-to-    |      | 18 Main Circuit Board Parts Location Diagram .....   | 22   |
| Speaker Distance: Direct Output .....         | 8    | 19 Filter Circuit Board Parts Location Diagram ..... | 22   |
| 9 Recommended Wire Gauge vs. Amplifier-to-    |      | 20 Transistor Lead Codes .....                       | 23   |
| Speaker Distance: 70-Volt Output              |      | 21 SR105 Power Amplifier Circuit Diagram .....       | 25   |
| (SR105A Only) .....                           | 8    |  |      |



# SR105 Power Amplifier

## DESCRIPTION

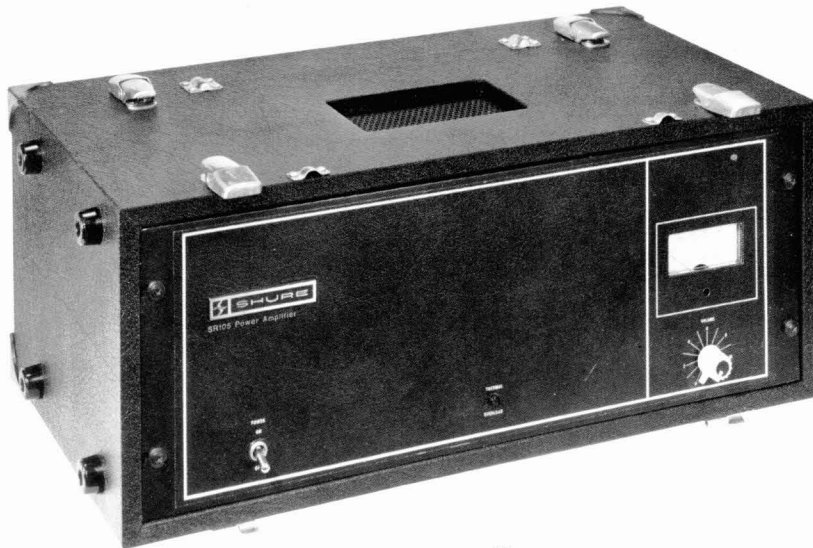

(Shown in A105A  
Carrying Case)

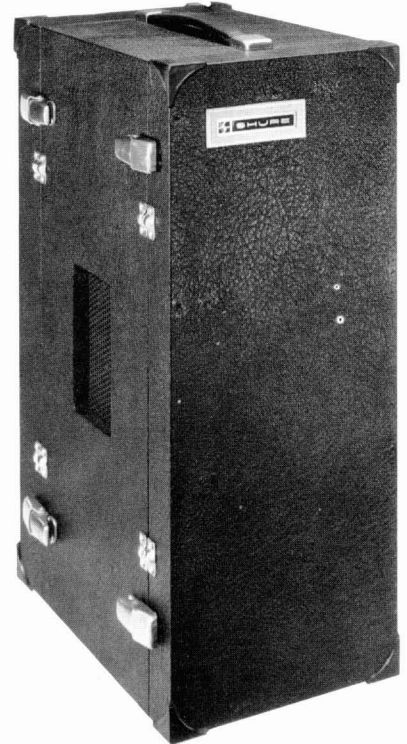

The Shure SR105 Power Amplifier is a high-power amplifier designed for sound reinforcement applications. It is capable of delivering 200 watts rms to a 4-ohm load, and is available in two models, the SR105A and SR105B. The SR105A Power Amplifier provides both a direct-coupled speaker output *and* a transformer-coupled constant-voltage, 70-volt output, while the SR105B Power Amplifier is equipped with a direct-coupled speaker output only. In this manual "Amplifier" refers to both SR105A and SR105B models unless otherwise specified.

The Amplifier is of rugged construction and is conservatively designed to provide reliable operation at high power levels with minimum distortion and phase shift. Used in conjunction with a suitable mixer-preamplifier or audio console such as the Shure Model SR101, a versatile, high-quality, high-power, sound reinforcement system may be assembled for use with a variety of speaker systems. Several SR105 Power Amplifiers may be interconnected (described under *Operating Instructions*) to provide greater power output for large installations and redundant operation. The basic direct-coupled speaker output capabilities of the Amplifier are well suited to the source-oriented speaker systems used in theatres, auditoriums, stadiums, ballrooms, and convention halls, in short, wherever maximum coverage with reserve power is required. The addi-

tional 70-volt output feature of the SR105A Power Amplifier makes it equally adaptable to source-oriented or distributed speaker systems such as those used for background music or announcements in industrial buildings, institutions or public places.

An Output Voltage Meter in the Amplifier facilitates adjustment and output level monitoring.

Silicon transistors and similar solid-state devices are used throughout the Amplifier. Short-circuit and thermal overload protection are design features which eliminate the need for special installation or operation precautions. All components are of the highest quality and are operated well within their respective ratings to assure maximum reliability under normal use conditions.

The Shure SR105 Power Amplifier is supplied with one 1.8m (6 ft) audio input connecting cable and an accessory package consisting of four rack-mounting screws, one Volume Control Cover, one Power On-Off Switch Cover, and one spare 5-ampere fuse.

The SR105A and SR105B Power Amplifiers are listed by Underwriters' Laboratories, Inc., and are listed by Canadian Standards Association as certified.

The A105A Portable Carrying Case accessory is designed specifically for use with the SR105 Power Amplifier.

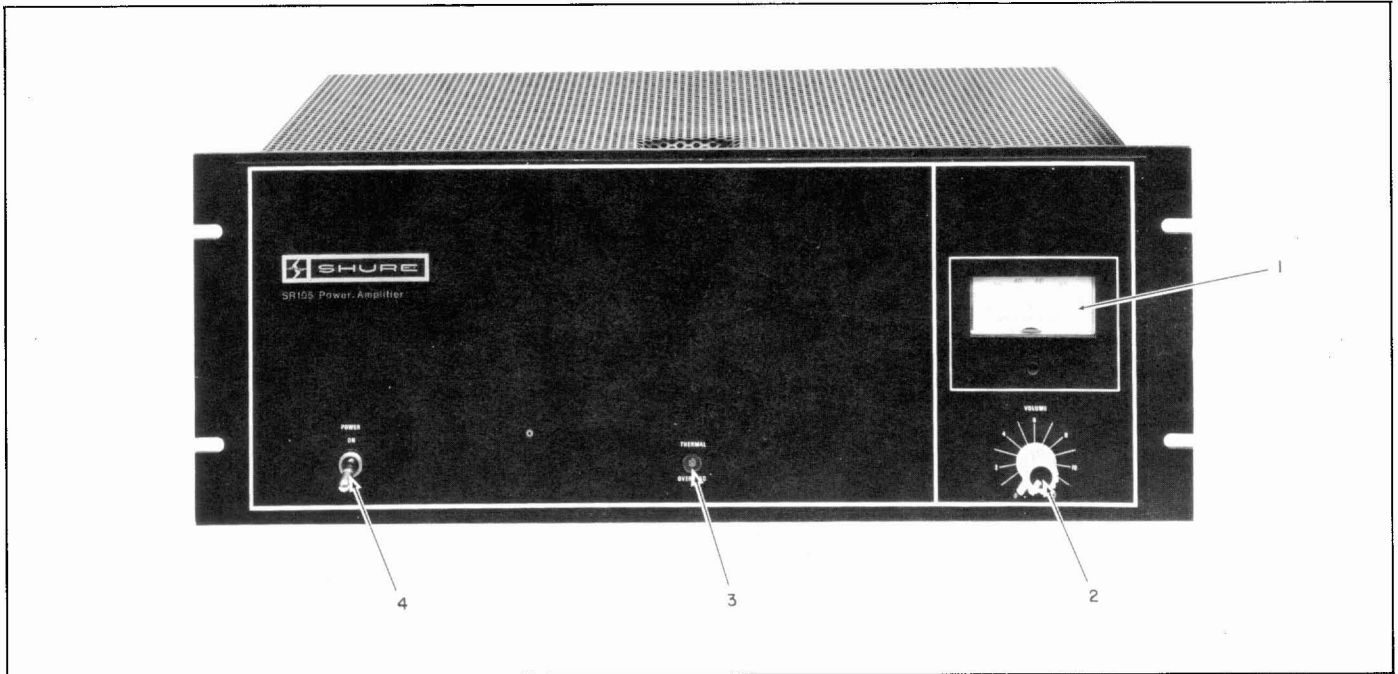

FIGURE 1. SR105 POWER AMPLIFIER FRONT PANEL

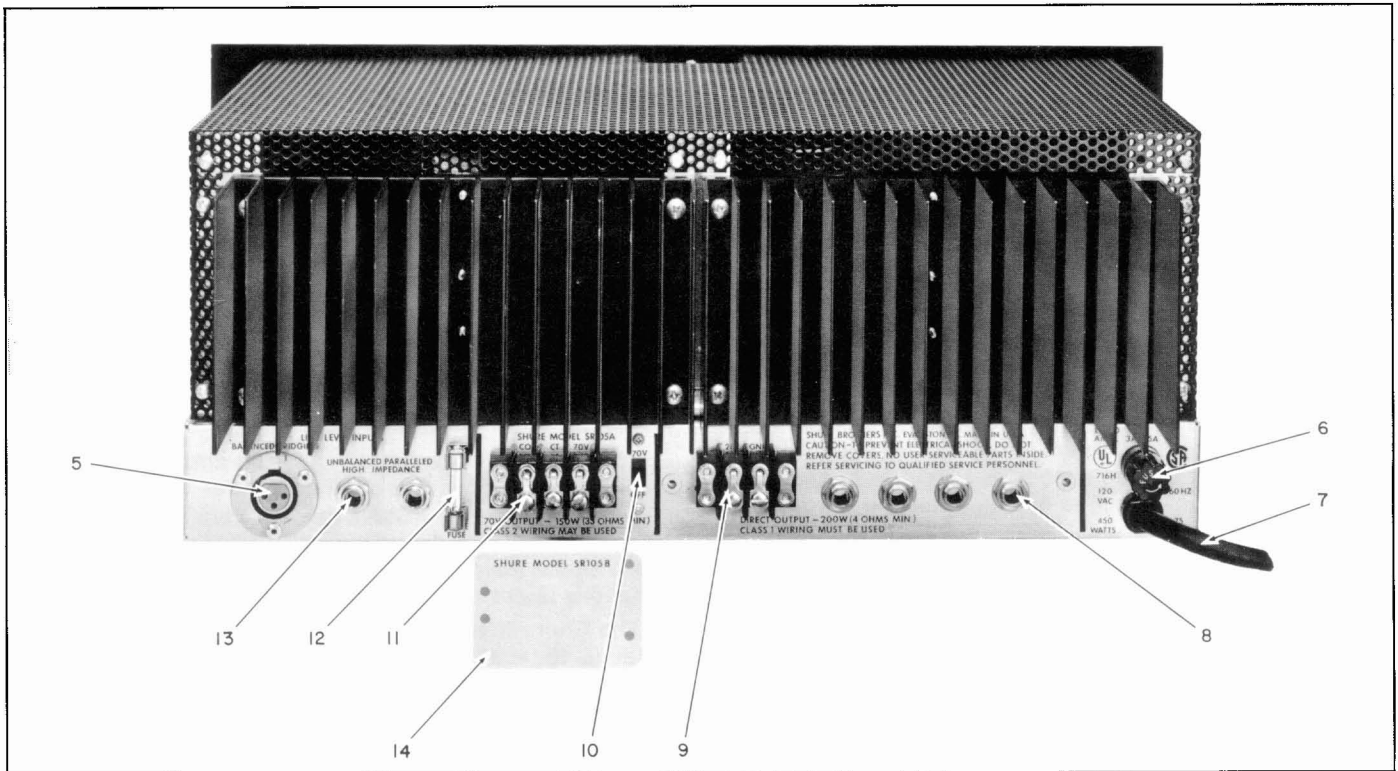

FIGURE 2. SR105 POWER AMPLIFIER REAR PANEL (SR105A MODEL SHOWN)

# SR105 Power Amplifier

## OPERATING INSTRUCTIONS

**FUNCTIONAL IDENTIFICATION** (Refer to Figures 1 and 2, Page 2).

1. **OUTPUT VOLTAGE Meter** — Indicates Amplifier output voltage in percentage of maximum voltage.
  2. **VOLUME Control** — Controls Amplifier output level.
  3. **THERMAL OVERLOAD Indicator Lamp** — Indicates Amplifier shutdown due to excessive heat sink temperature.
  4. **POWER ON-OFF Switch** — Applies ac power to Amplifier.
  5. **BALANCED BRIDGING Input Jack** — Provides for balanced bridging, high-impedance input connection.
  6. **3AG/5A Ac Line Fuse** — Protects Amplifier ac input line against overload.
  7. **Ac Line Cord** — Connects ac power to Amplifier power supply.
  8. **DIRECT OUTPUT Jacks (Four)** — Provide for output connection to direct-coupled speaker systems.
  9. **DIRECT OUTPUT Terminal Strip** — Provides for output connection to direct-coupled speaker systems.
  10. **70V-OFF Switch (SR105A Amplifier only)** — Activates 70-volt output transformer for use with distributed speaker systems.
  11. **70V OUTPUT Terminal Strip (SR105A Amplifier only)** — Provides for output connection to 70-volt distributed speaker systems.
  12. **SPARE FUSE Fuseholder** — Holds spare 3AG-5A power supply fuse.
  13. **UNBALANCED PARALLELED HIGH IMPEDANCE Input Jacks (Two)** — Provide unbalanced (one side grounded) input connections for use with high-impedance sources.
  14. **70-Volt Output Cover Plate (SR105B Amplifier only)** — Covers pre-drilled and marked area where Switch (10) and Terminal Strip (11) are located.
2. Set Switches (4,10) to OFF and VOLUME Control (2) to 0.
  3. Connect required speakers to Amplifier DIRECT OUTPUT jacks (8) and/or to terminal strip (9), using proper wire size and arranging speaker connections for total speaker load impedance as close to 4 ohms as possible. Remove DIRECT OUTPUT Cover (14) and use right-angle phone plugs to connect speakers to Amplifier. When using DIRECT OUTPUT Terminal Strip (9), thread wires through Cover grommet. Replace cover.

### CAUTION

In multiple speaker installations, be sure not to exceed maximum power rating of any speaker.

4. Connect audio console or microphone mixer output to Amplifier UNBALANCED PARALLELED HIGH IMPEDANCE Input Jack (13) (standard phone jack). For interconnections up to 15m (50 ft), use single-conductor, shielded, low-capacitance cable. For interconnections longer than 50 ft, use 600-ohm balanced line into Amplifier BALANCED BRIDGING Input Jack (5) (professional, 3-pin, female audio connector).
5. Connect additional power amplifiers or other auxiliary equipment as required to remaining Amplifier input jacks.
6. Connect line cord (7) to grounded 120 Vac  $\pm 10\%$ , 50/60 Hz source capable of supplying 450 watts.
7. With VOLUME Control (2) set at 0, turn front-panel POWER Switch (4) on. Adjust VOLUME Control to desired amplifier operating level.

### CONSTANT-VOLTAGE 70-VOLT SPEAKER OUTPUT (MODEL SR105A AMPLIFIER ONLY)

1. Connect auxiliary equipment as for direct speaker operation in steps 1, 2, 4, 5 and 6 above.
2. Connect required speakers to 70V OUTPUT Terminals (11) and, if necessary, DIRECT OUTPUT Connectors (8,9). Total speaker impedance should be as close to 33 ohms as possible. Be careful not to exceed Amplifier 150-watt power output capability. (See Output Connections, Page 6.)
3. Connect audio console or microphone mixer output to Amplifier UNBALANCED PARALLELED HIGH IMPEDANCE Input Jack (13) (standard phone jack). For interconnections up to 15m (50 ft), use single-conductor, shielded, low-capacitance cable. For interconnections longer than 50 ft, use 600-ohm balanced line into Amplifier BALANCED BRIDGING Input Jack (5) (professional, 3-pin, female audio connector).
4. Turn 70V-OFF Switch (10) to 70V.
5. Connect line cord (7) to grounded 120 Vac  $\pm 10\%$ , 50/60 Hz source.
6. With VOLUME Control (2) set at 0, turn front-panel POWER Switch (4) on. Adjust VOLUME Control to desired amplifier operating level.

### GENERAL OPERATING INSTRUCTIONS

#### WARNING

Voltages in this equipment are hazardous to life. Make all input and output connections with ac power disconnected. Refer servicing to qualified service personnel.

### DIRECT SPEAKER OUTPUT OPERATION (MODEL SR105A and SR105B AMPLIFIERS)

1. Install Amplifier before making electrical connections. Using hardware supplied, secure Amplifier in rack or carrying case, allowing at least 51 mm (2 in.) above and behind case for ventilation. Use forced-air cooling for multiple-amplifier installations.

## MOUNTING AND VENTILATION

The SR105 Power Amplifier is designed for rack-mounting in a standard 19-inch (483 mm) audio equipment cabinet rack and is supplied with the necessary mounting hardware. To insure adequate air circulation, a minimum clearance of 51 mm (2 in.) should be provided above and behind the Amplifier (see Figures 3, Page 4). If the cabinet ambient temperature reaches 43°C (110°F), forced air ventilation should be provided to avoid the possibility of thermal overload (see following section). The Amplifier may be operated in an ambient temperature range from -7° to 43°C (20° to 110°F) in continuous duty without derating.

The Amplifier may also be operated while mounted in a Shure A105A Carrying Case.

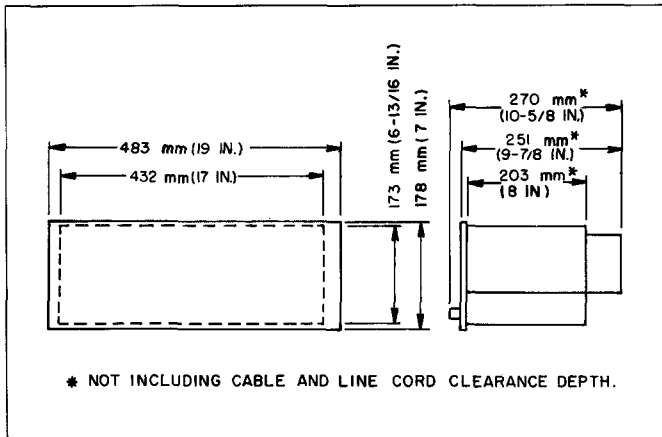

**FIGURE 3. SR105 POWER AMPLIFIER DIMENSIONAL OUTLINE DRAWING**

## THERMAL OVERLOAD

The SR105 Power Amplifier is equipped with thermal sensing switches on the output transistor heat sinks. The thermal switches are set to shut off ac power to the Amplifier when a temperature of 90°C (194°F) is attained on the heat sinks; the switches automatically recycle and re-apply power when the heat sink temperature drops to 73°C (164°F). A THERMAL OVERLOAD light (3), located on the front panel of the Amplifier, indicates if thermal cycling has occurred. Thermal cycling may occur if air is not allowed to circulate across the black finned heat sinks and through the grilles of the Amplifier, or if there is a prolonged short-circuit on the output.

## POWER REQUIREMENTS

The SR105 Power Amplifier is furnished with a three-conductor power cable and three-prong grounded plug (7). Connect the power cable to an outlet which supplies 120 ± 10% volts ac, 50/60 Hz power. The maximum power consumption at 120 volts under any normal operating condition is 450 watts (3.75 amperes at 120 volts). Idle power consumption with no input signal is nominally 20 watts. If extension cords are required to supply power to the Amplifier, a high quality 18-gauge or larger cord should be used.

A POWER toggle switch on the front panel (4) controls the application of ac power to the Amplifier. The tamper-proof cover supplied may be used to eliminate accidental movement of this switch.

Main ac power fusing is provided by a 5-ampere, type 3AG, cartridge-type fuse (6) located on the rear panel. A

spare ac power fuse is supplied for mounting in the clip on the rear panel (12).

Additional protection is provided by wired-in fuses in the main ac power circuit (F1, 8 amperes) and in the ac pilot lamp circuit (F3, 1 ampere). These fuses are located under the chassis.

## FUNCTIONAL CIRCUIT DESCRIPTION (See Figure 4, Page 5)

The inputs of the SR105 Power Amplifier consist of two unbalanced (grounded) phone jacks (13) and one balanced-bridging, three-pin, female audio connector (5). The balanced-bridging input is wired in parallel to the phone jacks after passing through an isolation transformer. The input signal then passes through the VOLUME Control (2), and if the Amplifier is an SR105A, either passes through a Filter Assembly and 70V-OFF Switch (10) to the Power Amplifier circuitry, or bypasses the Filter Assembly and goes directly to the Power Amplifier circuitry. In the SR105B Amplifier the signal passes directly from the VOLUME Control (2) to the Power Amplifier circuitry.

The Power Amplifier circuitry contains a dc balance adjustment to minimize idle power consumption and eliminate dc offset at the direct-coupled (28V) output. The balance adjustment is generally only performed when active Power Amplifier circuit components are replaced.

The metering circuit, located at the output of the Power Amplifier circuit, contains a meter calibration adjustment, a meter rectifier, and an output meter that indicates percentage of output voltage. NOTE: 100% is the maximum Amplifier output voltage prior to clipping regardless of load. Maximum power output is obtained with a direct-coupled speaker load impedance of 4 ohms, or a 70-volt output speaker load of 150 watts (33 ohms), or a combination of direct-coupled and 70-volt loads which results in optimum loading for maximum power output.

The Power Amplifier circuit output goes to four phone jacks (8) and one two-contact terminal strip (9). In the SR105A Amplifier, the output goes through the 70V-OFF Switch (10), a constant-voltage, 70-volt output transformer, and a three-contact terminal strip (11).

A detailed description of the Amplifier circuits and controls and their uses is provided in the following paragraphs of this section.

## INPUT CONNECTIONS

Three LINE LEVEL INPUTS Connectors are located on the rear panel of the Amplifier (see Figure 2, Page 2). A professional, three-pin, female audio connector (5)\* provides a balanced bridging, high-impedance input connection. Unbalanced, high-impedance input connections are provided by two standard ¼" phone jacks (13) wired in parallel.

The Amplifier may be driven to full-rated output by any audio console, preamplifier or microphone mixer capable of delivering 1.2 volts across a 25-kilohm load.

When using the Shure SR101 Audio Console as the mixer-preamplifier, connect the cable supplied with the Amplifier from one of the PROGRAM OUTPUTS Jacks labeled LINE LEVEL on the SR101 to one of the LINE LEVEL INPUT Jacks (13) labeled UNBALANCED PARALLELED HIGH IMPEDANCE on the Amplifier (see Figure 5A, Page 6). If a longer interconnecting cable is desired, a single-conductor, shielded, low-capacitance cable (such as Belden #8401, 8410, or 8411) should be used.

\*Designed to mate with Cannon XL Series, Switchcraft A3 (Q. G.) Series, or equivalent connector.

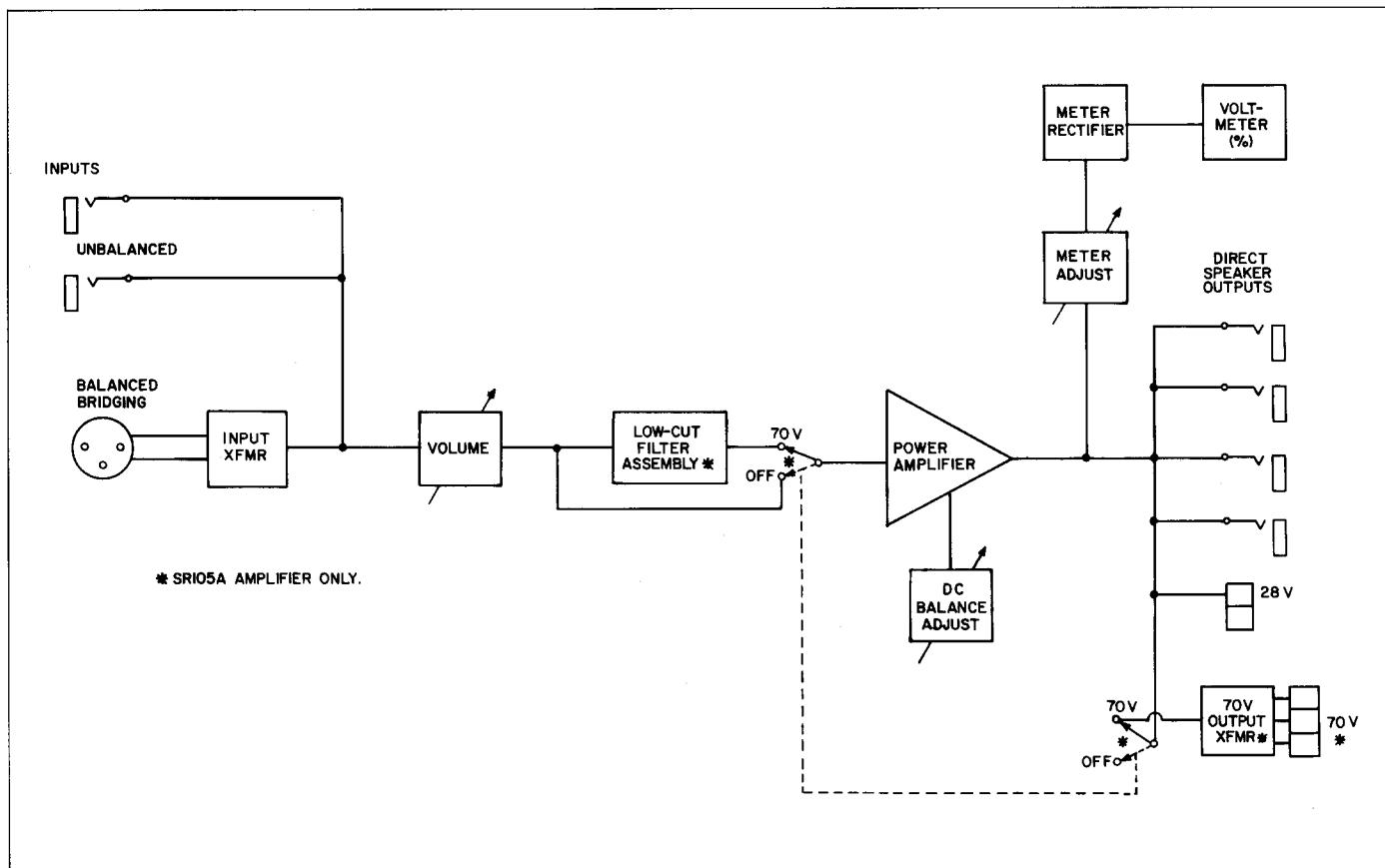

FIGURE 4. SR105 POWER AMPLIFIER BLOCK DIAGRAM

In applications where the Amplifier is located at a considerable distance from the mixer-preamplifier, electrical interference or excessive hum pickup may be encountered. Hum pickup may also be encountered over shorter distances as a result of ground loop conditions between the units. Under these circumstances, a balanced line, such as is used for low-impedance microphones, should be used for interconnections. A low-capacitance, two-conductor, shielded cable (such as Belden #8412 or 8422) is recommended. A professional, three-pin, female audio connector is required for connection to the mixer-preamplifier, and a similar three-pin *male* connector is necessary for connection to the Amplifier (see Figure 5B, Page 6). When wiring these connectors, connect the cable shield to pin 1 in each connector, one of the cable conductors to pin 2, and the other conductor to pin 3 in each connector. For balanced line operation, use the cable as described above to connect the mixer-preamplifier PROGRAM OUTPUTS three-pin connector labeled LINE LEVEL to the Amplifier LINE LEVEL INPUTS connector labeled BALANCED BRIDGING (5).

Since the two input jacks of the Amplifier are wired in parallel, one jack may be used as an auxiliary, high-level, unbalanced output to feed the signal to another Amplifier (SR105 or similar equipment) or the high-impedance input of a tape recorder. The three-pin input connector (5) is connected through an isolation transformer in parallel with the two input jacks (13). If not otherwise in use, the three-pin connector may be used as a balanced, high-level, signal source for a second Amplifier or other auxiliary equipment (see Figure 5C, Page 6).

Additional SR105 Power Amplifiers may be added to the system for a fail-safe type operation where complete redundancy is required. Refer to the section on *Bridging Connections* (Page 11).

Certain input equipment, such as passive equalizers, step attenuators and matching networks, may require a 600-ohm termination for optimum performance. (This is not required with any Shure products.) When a 600-ohm terminated input is required, a 620-ohm, 5%, 1/4-watt resistor must be connected to the terminals of the input cable connector (see Figure 5D, Page 6). This resistor must be connected between pins 2 and 3 of the three-pin connector, or between the tip and sleeve terminals of the phone plug. The resistor will fit inside the sleeve of the three-pin connector or phone plug. Be careful not to damage the wires, connections, sleeve or resistor when making this installation.

An occasion may arise where it is desirable or expedient to feed the Amplifier from a 70-volt line. This could be in connection with the expansion of an existing installation, or as a result of efforts to minimize cable runs in a new installation. An input signal for the Amplifier may be derived from a 70-volt line through the use of an attenuator (see *Adding Amplifiers in a 70-Volt System*, Page 10). When operating from a 70-volt line, the VOLUME Control (2) on the Amplifier should be set to the "7" position. With the recommended attenuator, this setting will produce approximately 28.3 volts at the DIRECT OUTPUT terminals (8,9), or 70 volts at the 70V OUTPUT terminals (SR105A Amplifier) (11) when the 70-volt input line is at 70 volts.

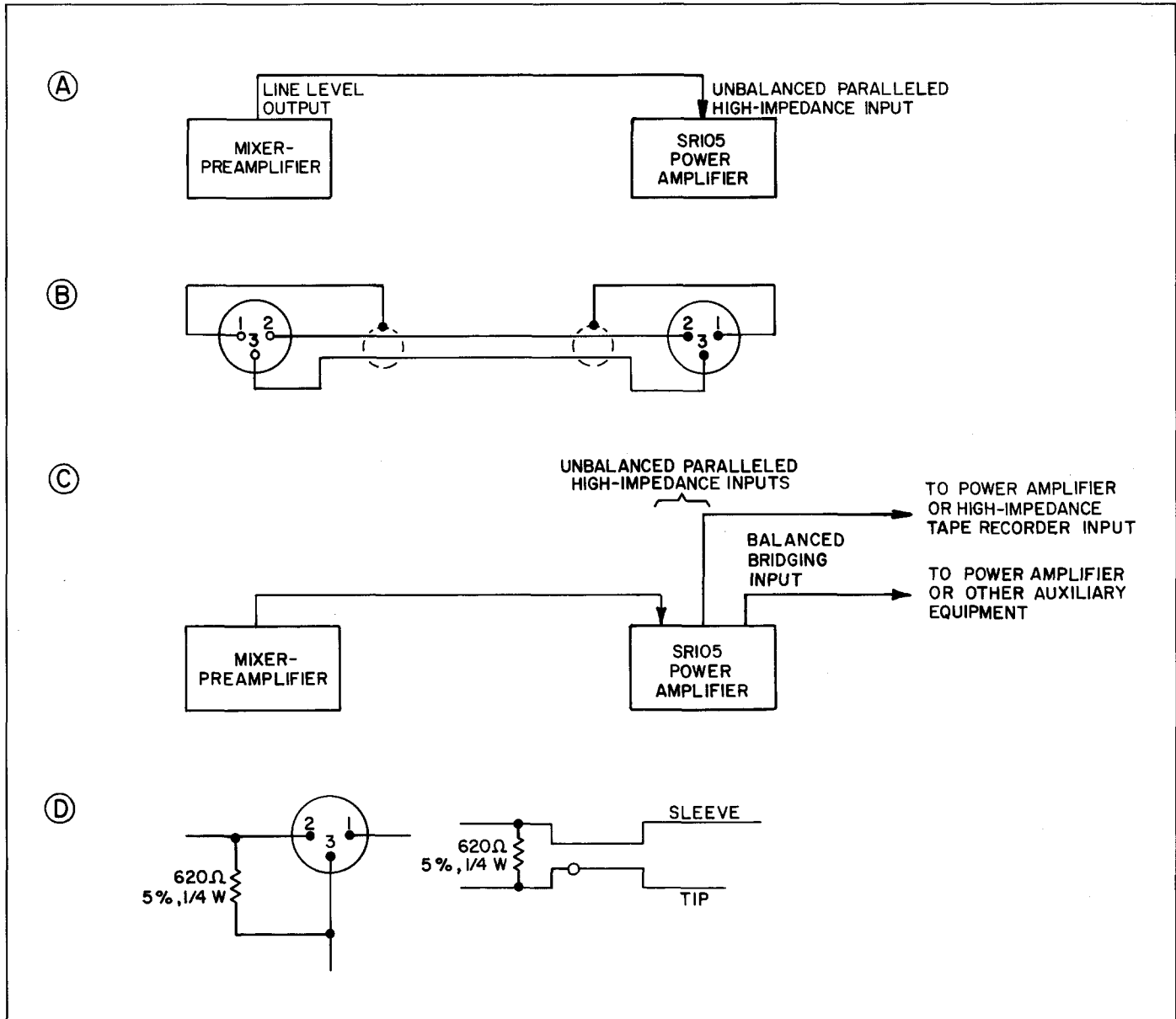

FIGURE 5. INPUT CONNECTIONS

### OUTPUT CONNECTIONS

Four standard 1/4" phone jacks (8) and one two-terminal barrier strip (9) on the rear panel of the Amplifier provide direct-coupled speaker output connections (see Figure 2, Page 2). All connectors are wired in parallel and provide for simultaneous connection of a number of speaker systems. A three-terminal barrier strip (11), labeled 70V OUTPUT (SR105A Amplifier only), provides for connection to the 70-volt output of the Amplifier (see Figure 2, Page 2). This output is present only when the 70V-OFF Switch (10) is set to the 70V position.

The Amplifier utilizes direct coupling between the output stage and the direct-coupled speaker output load. The full-rated 200-watt output of the Amplifier is obtained when the speaker load connected to the DIRECT OUTPUT terminals (8,9) is four ohms. The output voltage under these conditions is 28.3 volts. Speaker loads of less than four

ohms should not be used with this Amplifier. If less than four ohms is inadvertently used, no damage to the speakers or Amplifier will occur, but a reduction in power output and an increase in distortion will be experienced. Thermal shutoff of the Amplifier may also result.

It should be noted that various speaker loads will affect the output power of the Amplifier. See Figure 6, Page 7, to determine Amplifier output power for a given speaker load. Refer to the section entitled, *Amplifier-to-Speaker Matching* (Page 8) for assistance in calculating speaker load.

In the event that an SR105A Amplifier is operated in an application where the 70-volt output is not used, the 70V-OFF Switch (10) should be turned off. This disconnects the 70-volt transformer which would otherwise be operating without a load. If the transformer is allowed to operate in a no-load condition, it may activate the output transistor pro-

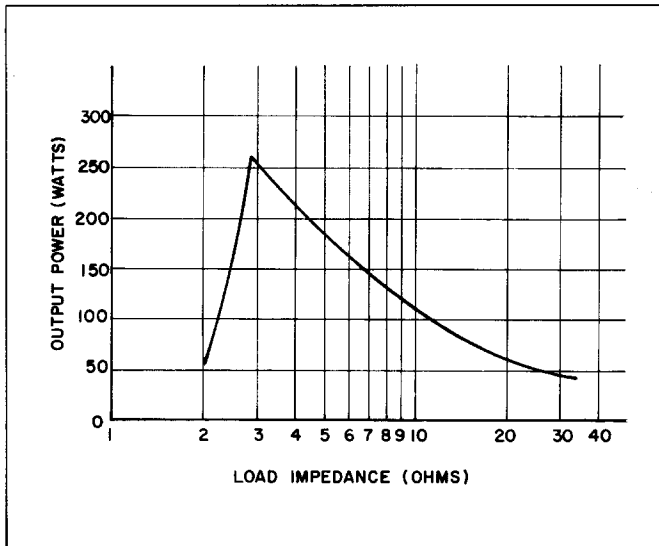

**FIGURE 6. TYPICAL OUTPUT POWER VS. LOAD IMPEDANCE FROM 2 OHMS TO 32 OHMS (1 KHz, 2% TOTAL HARMONIC DISTORTION) (DIRECT OUTPUT ONLY)**

tection circuitry and cause low-frequency breakup or distortion of the Amplifier audio output.

The 70-volt output of the SR105A Amplifier is transformer-coupled to facilitate the use of balanced lines in the long cable runs associated with distributed speaker systems. A center-tap connection to the secondary of the output transformer (CT) is provided on the 70-VOLT OUTPUT terminal strip (11). This terminal may be grounded to provide speaker lines which are balanced to ground. This is done by connecting a wire from the center-tap terminal to the ground terminal. This arrangement can be effective in eliminating hum induced in the speaker lines by strong external fields. It can also be effective in eliminating crosstalk and a tendency for system oscillation in applications where the 70-volt speaker output and low-level audio input are run in the same raceway.

The full-rated output of 150 watts from the SR105A Amplifier at the 70-volt output terminals (11) will be realized with a 33-ohm load. The output voltage under these circumstances will be 70.7 volts. In order to activate the 70-volt output of the Amplifier, turn on the 70V-OFF Switch (10). When using this output, care should be taken to see that the sum of the individual loads (i.e., each speaker in a distributed speaker system) does not exceed the 150-watt power output capability of the Amplifier.

It is possible to utilize both the direct-coupled speaker output and the 70-volt output of the SR105A Amplifier simultaneously, if desired. In this case, reference should be made to Figure 7, Page 7 to determine the power available to the 70-volt output as a function of the load on the direct speaker output. As an example, assume an 8-ohm speaker load is to be connected to the direct-coupled speaker output, and the 70-volt output is also to be used. Following the 8-ohm vertical line on the graph (Figure 7, Page 7) to the point where it intersects the curve, note that the *horizontal* line also passing through this point is 80 watts. This is the power available on the 70-volt output with a simultaneous 8-ohm direct output load.

## CAUTION

Parallel connection of the DIRECT OUTPUT Connectors (8,9), or the speaker cables between two SR105 Power Amplifiers, or the SR105 Amplifier and any other amplifier, should not be attempted. Balancing paralleled amplifiers is virtually impossible, and the circuitry mismatch cannot be balanced. The same precaution should be observed with regard to the 70V OUTPUT Connectors (11) of two SR105A Amplifiers, or the SR105A Amplifier and any other amplifier. Such a connection may result in damage to one or both amplifiers and is not covered by the Guarantee. This restriction does not extend to the series amplifier connections described in *Bridging Connections*, Page 11.

As indicated on the rear panel of the Amplifier, Class 2 wiring\* may be used for speaker connections to the DIRECT OUTPUT terminals (8,9) of the Amplifier as well as the interconnection between speakers in the direct-coupled distribution circuit. Class 2 wiring may be used for speaker connection to the 70V OUTPUT terminals (11) of the Amplifier or interconnection of speakers within this circuit.

In order to avoid appreciable power loss in the cables used for speaker connection, it is necessary to consider the length of cable required, the total impedance of the speakers being connected, and the Amplifier output (direct or 70-volt) being used. The graph presented in Figure 8, Page 8, for direct speaker output indicates the recommended wire gauge for various speaker loads and amplifier-to-speaker distances. As an example, assume two 16-ohm speakers are to be connected in parallel at a distance of 18.3m (60 ft) from the amplifier, and the direct output of the Amplifier is to be used. The total impedance of the speakers connected in parallel is eight ohms. Following the 8-ohm horizontal line on the graph (Figure 8) to the point where it intersects a vertical line representing 18.3m (60 ft), note that the nearest solid diagonal line to this point is labeled AWG 18. This is the recommended wire

\*As defined by U.S. National Electrical Code.

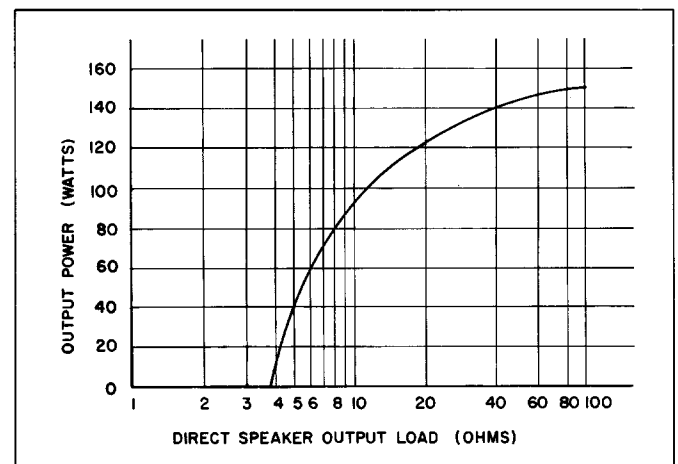

**FIGURE 7. 70-VOLT OUTPUT POWER VS. DIRECT OUTPUT LOAD IMPEDANCE FROM 4 OHMS TO 100 OHMS (SR105A ONLY)**

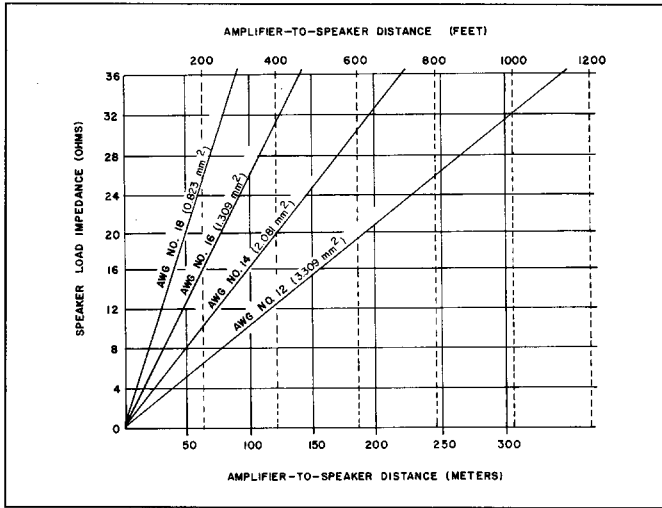

**FIGURE 8. RECOMMENDED WIRE GAUGE VS. AMPLIFIER-TO-SPEAKER DISTANCE: DIRECT OUTPUT**

gauge. This procedure should be followed for each speaker cable connected to the DIRECT OUTPUT Connectors (8,9) of the Amplifier. If a point plotted on the graph falls between two of the wire gauge lines, the larger of the two should be the wire gauge used. This will limit the power loss in the cable to less than 10%.

The graph of Figure 9, Page 8, provides wire gauge recommendations for use with the 70-volt output of the SR105A Amplifier. A 70-volt line is usually used for distributed speaker systems where many speakers and long cable runs are involved. The wire gauge value determined from the graph would be satisfactory for the entire cable run in a distributed speaker system. However, it is possible

to reduce the wire size in increments as the speaker load becomes less toward the end of the cable run or as branches are split off the main line. The economy of such an arrangement will vary depending upon the details of each installation and should be evaluated accordingly.

**AMPLIFIER-TO-SPEAKER IMPEDANCE MATCHING  
DIRECT SPEAKER OUTPUT**

In order to obtain maximum transfer of Amplifier power to the speaker load at the direct speaker output and reduce distortion, the total impedance of the speaker load should be as near to four ohms as practical under the existing circumstances (see Figure 6, Page 7). If the speakers being used have a rated impedance of 16 ohms (such as the Shure SR102 and SR103), then four such speakers connected in parallel present a total load impedance of four ohms to the direct speaker output of the Amplifier. This is an ideal match to the Amplifier. If, as often happens, an exact match is not possible, it is desirable to have a speaker load higher than the Amplifier minimum load impedance.

In general, if more than one speaker is to be connected to the DIRECT OUTPUT Connectors (8,9) of the Amplifier, a determination should be made as to which method — series, parallel or series-parallel interconnection of speakers — will provide the best match to the Amplifier. To calculate the total impedance of a number of speakers connected in series, merely add the individual speaker impedance values together. To calculate the total impedance of a number of speakers of identical impedance connected in parallel, divide the impedance of one speaker by the number of speakers in the group. For example, the total impedance of three 16-ohm speakers connected in parallel is 16 divided by 3, or 5.3 ohms.

In the event that a group of speakers of different individual impedances are connected in parallel, the total impe-

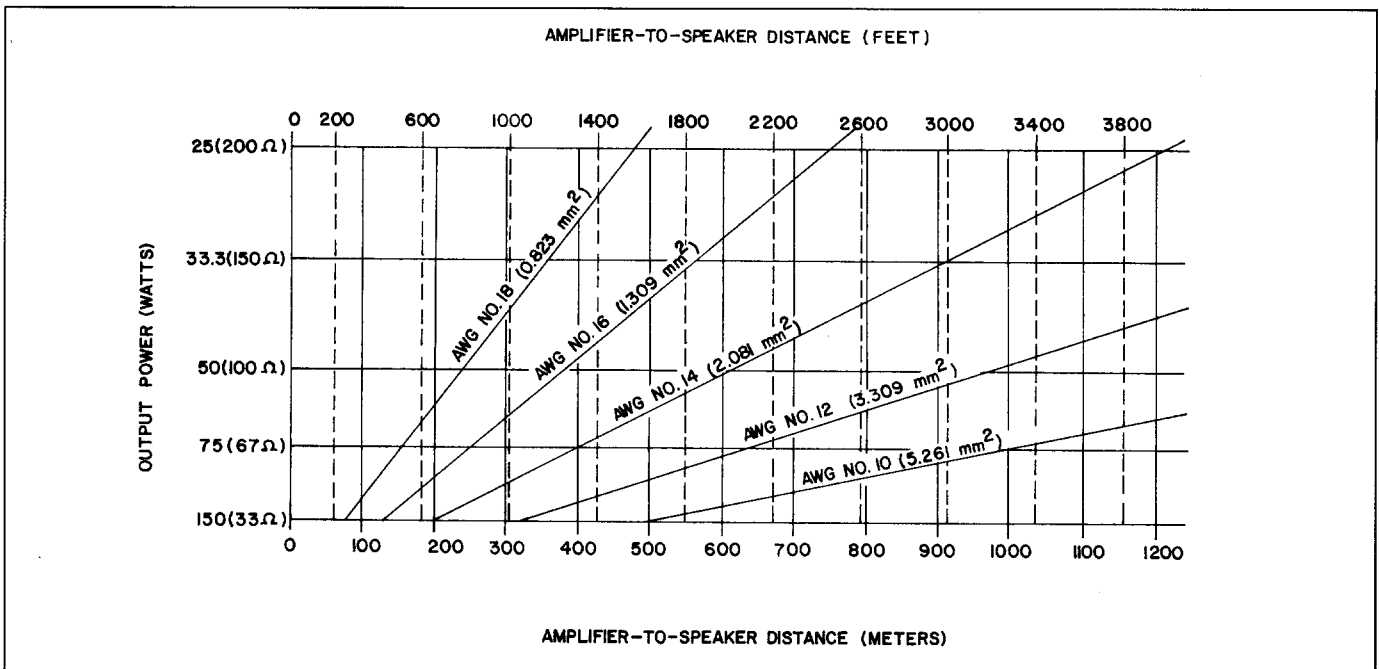

**FIGURE 9. RECOMMENDED WIRE GAUGE VS. AMPLIFIER-TO-SPEAKER DISTANCE: 70-VOLT OUTPUT (SR105A ONLY)**

dance may be calculated by the formula:

$$\frac{1}{Z_T} = \frac{1}{Z_1} + \frac{1}{Z_2} + \frac{1}{Z_3} \dots \text{etc.}$$

where  $Z_T$  is the total impedance,  $Z_1$  is the impedance of the first speaker,  $Z_2$  is the impedance of the second speaker, and so forth, with a total number of fractional terms equal to the total number of speakers in the group. Before attempting to add the individual fractions, a common denominator for all fractions must be determined. For example, if an 8-ohm and a 16-ohm speaker are connected in parallel, the expression is written:

$$\frac{1}{Z_T} = \frac{1}{8} + \frac{1}{16}$$

Examination indicates that 16 would be an appropriate common denominator, allowing the expression to be rewritten as follows:

$$\frac{1}{Z_T} = \frac{2}{16} + \frac{1}{16}$$

and simplifying,

$$\frac{1}{Z_T} = \frac{3}{16}$$

Taking the reciprocal of (inverting) the final expression gives:

$$Z_T = \frac{16}{3} = 5.3 \text{ ohms}$$

For a series-parallel interconnection of different speaker impedances, determine the total parallel-connected speaker impedance, and add it to the total of series-connected impedances. The sum is the total load impedance.

In planning a multiple speaker installation, the maximum power ratings of the individual speakers being used should be kept in mind. This is particularly important where speakers of different impedance values are connected to the DIRECT OUTPUT Connectors (8,9). For example, assume an 8-ohm and a 16-ohm speaker are connected in parallel across the Amplifier output and the Amplifier is operated at full-rated output. Figure 6, Page 7, shows that approximately 120 watts are developed across the 8-ohm speaker, while only 60 watts are produced across the 16-ohm speaker. The power ratings of the speakers employed must be evaluated accordingly.

#### 70-VOLT OUTPUT

When the 70-volt output of the SR105A Amplifier is utilized, matching the speaker load to the Amplifier output impedance is not necessary. The only requirement is that the total wattage of the speaker load connected to the 70-volt output does not exceed the power rating of the Amplifier.

In a 70-volt speaker system it is standard practice to couple each speaker to the 70-volt line with a line transformer. These transformers are equipped with tapped secondary windings to accommodate various speaker impedances. The primary winding is also tapped and labeled with the

wattage rating applicable to each tap. For example, the Shure A102A, a 50-watt transformer, has taps at 50, 25, 12 and 6 watts. (Transformers are available at various power ratings to suit the requirements of the application.) The primary taps allow adjustment of the power level delivered to the speaker when the transformer is connected to the 70-volt line. Connection of the 50-watt tap to the 70-volt line produces 50 watts across the speaker when the audio signal level on the line is 70 volts. Similarly, use of the 25-watt tap produces 25 watts across the speaker.

The total load in watts presented by a 70-volt multiple speaker system is the sum of the individual speaker loads. The value of each individual speaker load is indicated by the wattage rating of the transformer primary tap connected to the 70-volt line. For example, assume only two speakers are connected to a 70-volt line, the first using a 50-watt primary tap and the second using a 25-watt tap. The total load across the 70-volt line is therefore 50 plus 25, or 75 watts.

In the design of sound reinforcement installations, good engineering practice allows for change or growth. An example of this is a 70-volt installation requiring 300 watts. This system *could* be handled by two 70-volt lines of 150 watts each, connected individually to two SR105A Amplifiers. This system would be operating at full capacity with no room for expansion. The preferred installation would be *three* 70-volt lines of 100 watts each, connected individually to three SR105A Amplifiers. This arrangement allows additions or changes in each 70-volt line of up to 50 watts.

#### OUTPUT VOLTAGE METER

The OUTPUT VOLTAGE Meter (1) provides a convenient aid for adjusting and monitoring the Amplifier operating level. The meter scale is calibrated in percent, with 100% being equivalent to the maximum output voltage of the Amplifier, prior to clipping. The performance of the meter is similar to that of a VU meter and it responds to program material in a similar manner.

It should be noted that a 100% meter indication represents a signal level of 28.3 volts rms across the DIRECT OUTPUT (8,9). The maximum rated amplifier power output of 200 watts is obtained only when the total speaker load is 4 ohms across the DIRECT OUTPUT. With loads other than 4 ohms, a 100% meter indication represents a lower power output, e.g., for a total speaker load of 8 ohms, a 100% reading indicates a power output of 100 watts. Note that it is not possible to obtain a greater power output with this load.

Figure 6 may be used as an approximate guide to the power indicated by a 100% meter indication for various direct speaker loads. Note that while the meter is calibrated for 28.3 volts output, the typical output power available is somewhat higher and is indicated by meter readings greater than 100%.

In the SR105A Amplifier, a 100% indication represents a signal level greater than 70.7 volts rms across the 70V OUTPUT Terminals (11). The OUTPUT VOLTAGE Meter (1) may be recalibrated for a 100% indication with 70.7V output. Maximum 70-volt amplifier power output is obtained with a 150-watt load (33 ohms) across the 70V OUTPUT Terminals. Similarly, maximum power output may be obtained with a combination of direct and 70-volt loads (see Figure 7, Page 7).

The relationship between the OUTPUT VOLTAGE Meter (1) reading and the Amplifier direct-coupled output power is illustrated in the following table:

| Meter Reading | Output Power |
|---------------|--------------|
| 100%          | 1X           |
| 86.7%         | 3/4X         |
| 70.7%         | 1/2X         |
| 50%           | 1/4X         |
| 33.3%         | 1/10X        |
| 10%           | 1/100X       |

In most applications, the VOLUME Control (2) setting of the Amplifier is determined by the sound level requirements of the area being served. Initial adjustments are made in the audio console feeding the Amplifier to set the average program output level to a value convenient for monitoring on the audio console VU meter, usually 0 VU. This can be done either with program material or with an internal tone oscillator as in the Shure SR101 Audio Console. With this signal as an input to the Amplifier, adjust the VOLUME Control to provide the desired sound level from the speakers connected to the Amplifier. At this point, it is important to note the reading of the OUTPUT VOLTAGE meter (1). If the average reading is 70% or higher, it is likely that peak excursions in the program material will exceed 100% and enter the clipping region of the Amplifier. If the program material is of relatively constant level, as in "hard rock" music, this operating condition may be acceptable or even desirable. It should be noted that a moderate amount of clipping is not readily detectable and is tolerated by some users in the interests of maintaining a higher average sound level at the amplifier output. If the dynamic range of the program material is expected to be large, as in a live orchestral or dramatic production, it is advisable to set the output voltage level to 50% or less to reduce the possibility of noticeable clipping on loud passages. In either case, to achieve the best overall performance from the sound system, the operator should keep in mind the operating level he has set up for the Amplifier, and control the console output accordingly.

The tamper-proof cover supplied is designed to replace the pull-off VOLUME Control knob (2) and keep the VOLUME Control at a preset position.

#### BASIC OPERATING HINTS

Should any difficulty be encountered in Amplifier operation, the problem may often be traced to some simple source such as an error in interconnection. The following is offered as a basic guide to problems of this sort.

*Symptom:* Amplifier is "dead" (no output, OUTPUT VOLTAGE Meter lamps out)

- Check:*
1. Check that ac power source is "live" and that Amplifier is plugged in.
  2. Check that POWER ON-OFF Switch (4) is on.
  3. Check to see that rear-panel 3AG/5A Fuse (6) is good.
  4. Check that THERMAL OVERLOAD Lamp (3) is not lit.

*Symptom:* Amplifier is "dead" (no output, OUTPUT VOLTAGE Meter lamps lit)

- Check:*
1. Check that VOLUME Control (2) is set high enough.
  2. Check for defective input cable or source.
  3. Check for defective output cables or speakers.
  4. Check for input and output cables reversed.

*Symptom:* No 70-volt output (direct output present) (SR105A only)

- Check:*
1. Check that 70V-OFF Switch (10) is set to 70V.
  2. Check for defective 70-volt output cables or speakers.

*Symptom:* Low or distorted output

- Check:*
1. Check for incorrect speaker load, shorted or defective cables, and proper connections.
  2. Check that speaker power handling capability is adequate.
  3. Check that 70V-OFF Switch (10) is not turned on without a 70-volt load (SR105A; direct output operation only).
  4. Check that output cables are of sufficient size (gauge) for load.

*Symptom:* Hum or noise in output

- Check:*
1. Check for defective source or input cable by disconnecting input cable.
  2. Check need for balanced line on long cable runs or to avoid ground loop condition between units.
  3. Check speaker line for balance (should not be grounded at speaker).
  4. Check 70V OUTPUT Terminal Strip (11); grounding the center-tap (CT) terminal may reduce or eliminate condition (SR105A only).

## SR105 Power Amplifier

### SPECIAL OPERATING INSTRUCTIONS

The information contained in this section is provided to more fully utilize the capabilities of the SR105 Power Amplifier.

#### ADDING SR105A AMPLIFIERS IN A 70-VOLT SYSTEM (CASCADED)

For added power or when additional speakers are to be installed, an additional SR105A Amplifier may be added to

an existing 70-volt system. The Amplifier may be installed either at the end, or anywhere along the system, by using an attenuator such as that shown in Figure 10, Page 11. Connect the attenuator to the 70-volt line as shown, and connect the attenuator plug to the BALANCED BRIDGING Input Jack (5) on the added Amplifier. Set the VOLUME Control (2) on the added Amplifier to 7 to obtain a 70-volt output when the system voltage is at 70 volts. This will pro-

duce approximately 28.3 volts at the DIRECT OUTPUT terminals (8,9), or 70 volts at the 70V OUTPUT terminals (11) when the 70-volt input line is supplying 70 volts.

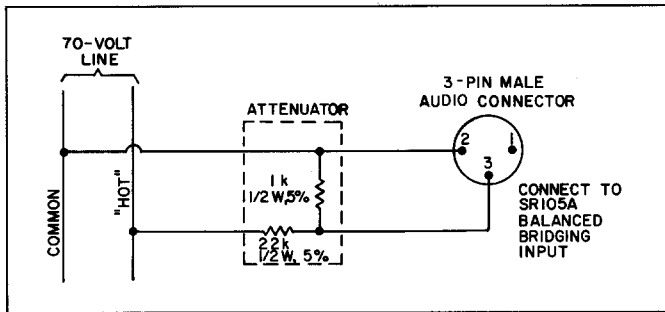

FIGURE 10. 70-VOLT SYSTEM ATTENUATOR

### BRIDGING CONNECTIONS

If greater power or optimum system reliability becomes extremely important, two Amplifiers may be connected in series (never in parallel!) to obtain an output of 400 watts into an 8-ohm load, or 200 watts into a 16-ohm load (6 ohms minimum load). To determine available power, divide the *actual* load impedance by two and, referring to Figure 6, Page 7, double the output power shown on the graph. This connection also provides a fail-safe, or redundant, system: if one Amplifier fails, the second remains functional at its normal power output. This series connection of amplifier outputs is commonly referred to as a bridged configuration.

Connect the Amplifier balanced inputs out of phase as shown in Figure 11, Page 11, with the speaker load connected between the two 28V terminals of the DIRECT OUTPUT Terminal Strips (9). Connect the two GND terminals together.

If a 140-volt output is required (SR105A Amplifier only), two SR105A Amplifiers may be connected in series as described above, except that the 70-volt outputs are used. Connect the speaker load to the 70V terminals (11) of the two SR105A Amplifiers and connect the COM terminals together. Use Class 1 wiring.\*

### ADDING HEADPHONE JACK TO SPEAKER CONNECTIONS

If it is desirable to monitor the Amplifier direct output through headphones, a headphone output may be fabricated as follows. Obtain parts listed below or their equivalent.

\*As defined by U.S. National Electrical Code.

| Qty. | Part                                | Recommended Type               |
|------|-------------------------------------|--------------------------------|
| 1    | Phone Jack                          | Switchcraft 12-B               |
| 1    | Phone Plug                          | Switchcraft 280                |
| 1    | Volume Control (L-Pad)              | Switchcraft 666PI or 656       |
| 1    | Transformer, 25V Line to Voice Coil | Essex-Stancor A-8095 or A-8096 |

Connect the parts as shown in Figure 12, Page 11. Make certain the "hot" speaker lead (28V) is connected to a one-watt or less tap on the 25-volt transformer; this connection sets the maximum headphone volume. If only stereo headphones are to be used, interconnect the tip and sleeve contacts of the headphone jack. If it is desired to monitor the 70-volt output of an SR105A Amplifier, substitute a 70-volt line to voice coil transformer for the 25-volt transformer listed above.

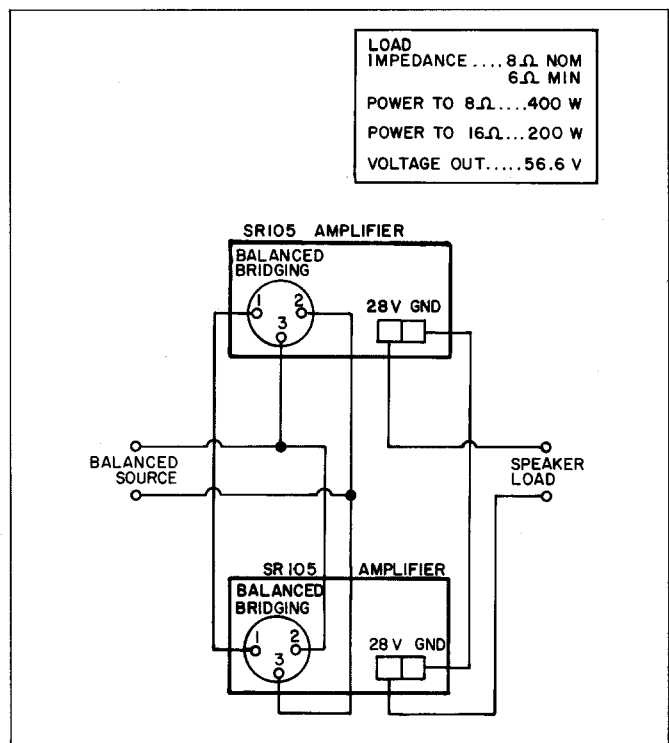

FIGURE 11. BRIDGED AMPLIFIER CONNECTIONS

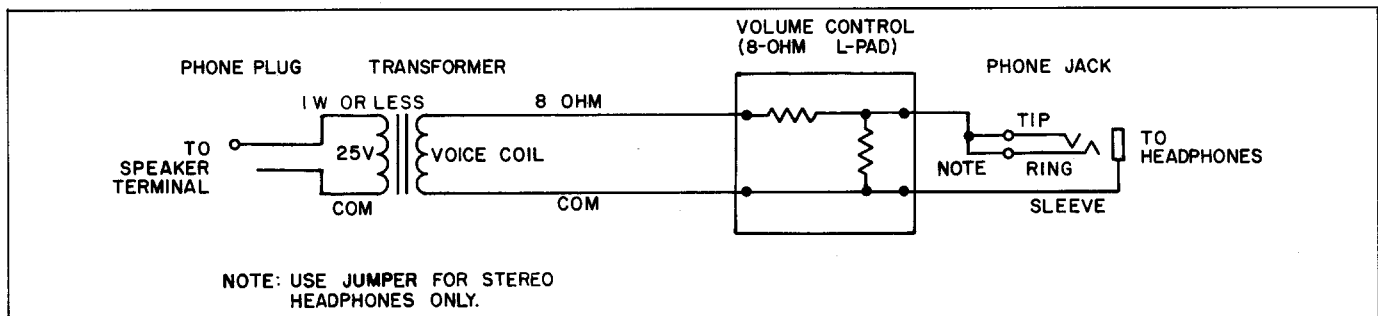

FIGURE 12. HEADPHONE JACK FOR SPEAKER CONNECTIONS

# SR105 Power Amplifier

## SERVICE INSTRUCTIONS

### AMPLIFIER SERVICE (See Guarantee)

The SR105 Power Amplifier uses components of the highest quality, operating well within their respective ratings to assure long life.

### WARNING

Voltages in this equipment are hazardous to life. Make all input and output connections with ac power disconnected. Refer servicing to qualified service personnel.

### REPLACEMENT PARTS

Parts that are readily available through local electronic parts distributors are not shown on the accompanying Parts List. Their values are shown on the Circuit Diagram (Figure 21, Page 25). Commercial parts not readily available and unique parts are shown on the Parts List and may be ordered directly from the factory.

The commercial alternates shown on the Parts List are not necessarily equivalents, but are electronically and mechanically similar, and may be used in the event that direct factory replacements are not immediately available. To maintain the highest possible performance and reliability, Shure factory replacement parts should be used. When ordering replacement parts, specify the Shure Replacement Kit Number, description, product model number and serial number.

### FUSE REPLACEMENT

To replace line fuse F2 (with no apparent problems in the unit), disconnect the line cord and remove the rear-panel fuseholder cap. Replace the defective fuse *only* with a 3AG-5A fuse.

NOTE: The following symbol on the rear panel denotes a fast operating fuse.

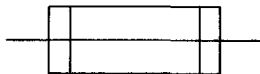

### CAUTION

If trouble symptoms — overheating (thermal cycling), erratic operation, etc. — were apparent before the fuse blew, or if the replacement fuse blows, troubleshoot the Amplifier carefully to find the source of the trouble. Do not continue to replace fuses unless the trouble has been corrected.

The Amplifier also contains two wired-in fuses, one in series with rear-panel line fuse F2 (F1, 3AG-8A) and one in the meter lamp circuit (F3, 3AG-1A). If replacement becomes necessary, replace only with identical fuses.

### BOTTOM PLATE REMOVAL

To remove the chassis bottom plate, turn the Amplifier upside-down and remove the 10 screws located at the edges of the chassis.

### COVER REMOVAL

To service components on the top of the chassis, the protective cover grille (MP7) must be removed. This is done by removing one screw from the top, two screws from each side, and eight screws from the back surface. To remove, slide cover up and to the rear of the Amplifier.

### LAMP REPLACEMENT

Two bayonet-base pilot lamps (PL2, PL3) illuminate the scale of the OUTPUT VOLTAGE meter. These lamps are mounted on the top surface of the chassis behind the meter as shown in Figure 13, Page 13. To replace a lamp, remove the grille cover and the nut on the lamp bracket mounting stud. Swing the bracket up and out until the lamp is accessible. Push the lamp inward, twist it 1/8-turn counterclockwise, and withdraw it from its socket. After replacing the lamp, reposition the assembly under the meter and tighten the bracket nut. Replace the grille cover.

### DC OUTPUT BALANCE ADJUSTMENT

In order to minimize the idle power consumption of the Amplifier and eliminate dc offset at the direct-coupled output, a dc balance control (R4-DC BAL.) has been provided. This control is located on the Main Circuit Board under the chassis, as shown in Figure 14, Page 14, and may be reached by removing the bottom cover. The dc balance of the Amplifier should be checked and adjusted as necessary whenever any circuit components are replaced.

The dc balance adjustment is made with the Amplifier VOLUME control (R41) full counterclockwise and no speaker load. If the Amplifier being adjusted is equipped with a 70-volt output (SR105A), the 70V-OFF Switch (S4) should be turned off. Connect a dc voltmeter (preferably with a 0.1 Vdc full-scale range) across the terminals of the DIRECT OUTPUT terminal strip (TS1).

### CAUTION

The polarity of any dc voltage at the output may be either positive or negative and could be as much as 10 volts; care should be exercised in connecting the meter such that an on-scale reading is obtained.

Carefully adjust the dc balance control for 0 Vdc  $\pm$ 25 mV at the output.

If the 70V-OFF Switch was moved to make this adjustment, return it to its original position. Replace the bottom cover.

### OUTPUT VOLTAGE METER CALIBRATION

In the event that the OUTPUT VOLTAGE Meter (M1) or its associated circuitry is repaired, a meter calibration check and adjustment should be performed. With the Amplifier off, check the zero position of the meter. If it is not on zero, use a small screwdriver to turn the meter zero

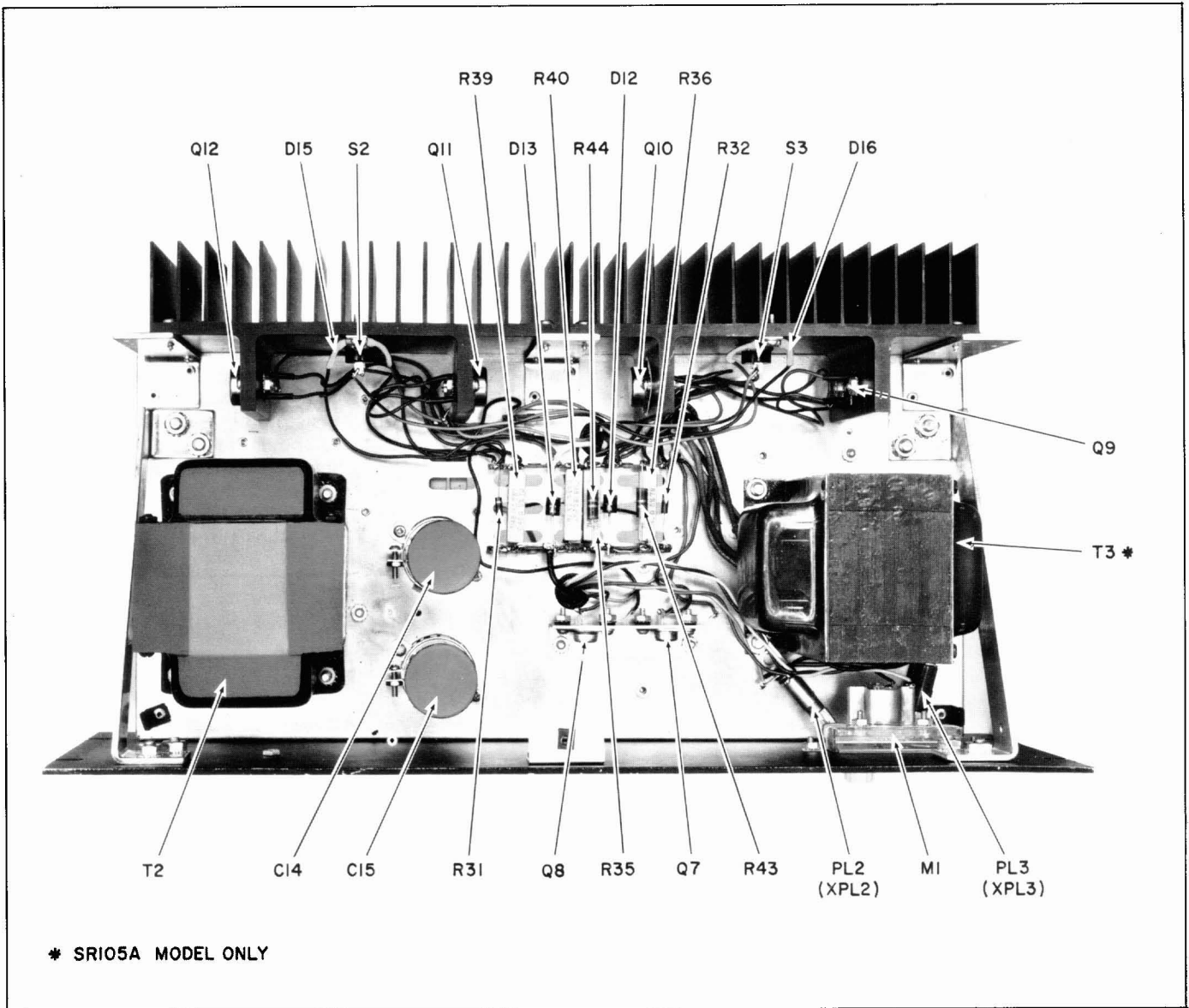

**FIGURE 13. SR105 POWER AMPLIFIER TOP VIEW, COVER REMOVED (SR105A MODEL SHOWN)**

adjustment screw below the meter face until the needle is properly positioned. With no load on the Amplifier (speaker disconnected), connect an ac voltmeter across one of the DIRECT OUTPUT Terminals. Turn the Amplifier on and apply a 1 kHz sine-wave signal at approximately 3 volts rms to one of the Amplifier inputs. Adjust the VOLUME Control for 28.3 volts at the output. Remove the bottom cover and adjust the Meter Adjust resistor (R27-METER ADJ. located on the Main Circuit Board under the chassis as shown in Figure 14, Page 14) for a 100% reading on the OUTPUT VOLTAGE Meter. No further adjustment is necessary. Replace the bottom cover.

To calibrate the meter for a 100% indication with 70.7V output, connect the voltmeter and an appropriate load across the 70V OUTPUT terminals and proceed as above.

**PRINTED CIRCUIT BOARD REMOVAL**

The underside of the SR105A Amplifier chassis contains two printed circuit boards: a Main Circuit Board and a Filter

Circuit Board. (The SR105B Amplifier contains only a Main Circuit Board.) The foil side of the boards may be made accessible for servicing without disconnecting any leads by removing the four Phillips head screws securing the board. The boards may be completely removed as follows (see Figure 14, Page 14). Remove the bottom cover. On the Main Circuit Board, remove all 15 interconnecting leads from the push-on board terminals, noting connections as listed in the table below.

**CAUTION**

Similar wire colors are used in different circuits; make sure proper re-connections can be made. Take care not to bend or break the push-on terminals.

Remove the four Phillips head screws from the board and remove the board from the chassis.

The Filter Circuit Board may be removed in the same manner. Replace bottom cover after servicing boards.

| Main Circuit Board |             |        |              |
|--------------------|-------------|--------|--------------|
| Letter             | Wire Color  | Letter | Wire Color   |
| A                  | Blue        | J      | Yellow/Black |
| B                  | Black       | K      | Orange/Black |
| C                  | Gray        | L      | Orange       |
| D                  | Green/Black | M      | Brown        |
| E                  | Violet      | N      | Yellow       |
| F                  | Red         | P      | Green        |
| G                  | White       | R      | White        |
| H                  | White       |        |              |

| Filter Circuit Board |            |        |              |
|----------------------|------------|--------|--------------|
| Letter               | Wire Color | Letter | Wire Color   |
| S                    | Red        | W      | White        |
| T                    | Blue       | X      | White        |
| V                    | Yellow     | Y      | Yellow/Black |

NOTE: Production variations may result in wire colors differing from those in the table.

### SMALL SIGNAL AND PREDRIVER TRANSISTORS

Transistors Q1 through Q6, Q13, Q14, and Q201 through Q203 are mounted on printed circuit boards. When replacing these transistors it is imperative that proper lead configuration be followed. A minimum of soldering heat should be used to avoid damage to the transistor or printed circuit board. Refer to the *Notes to Circuit Diagram* (Figure 20, Page 23) for the transistor lead codes.

### DRIVER TRANSISTORS

Driver transistors Q7 and Q8 (Figure 13, Page 13) are mounted on a bracket located on the top surface of the Amplifier chassis. Before removing these transistors, write down the lead color and location at each transistor solder junction. When replacing transistors, apply Wakefield Type 120 thermal joint compound to each side of the insulating wafer to provide good heat transfer from transistor to bracket. After replacement and before connecting transistor leads, check the transistors between case and chassis with an ohmmeter; there should be no continuity. Be sure that these transistors are not interchanged in the circuit; they are not identical devices. Q7 is an NPN transistor and Q8 is a PNP transistor. Refer to the *Notes to Circuit Diagram* (Figure 20, Page 23) for the transistor lead codes.

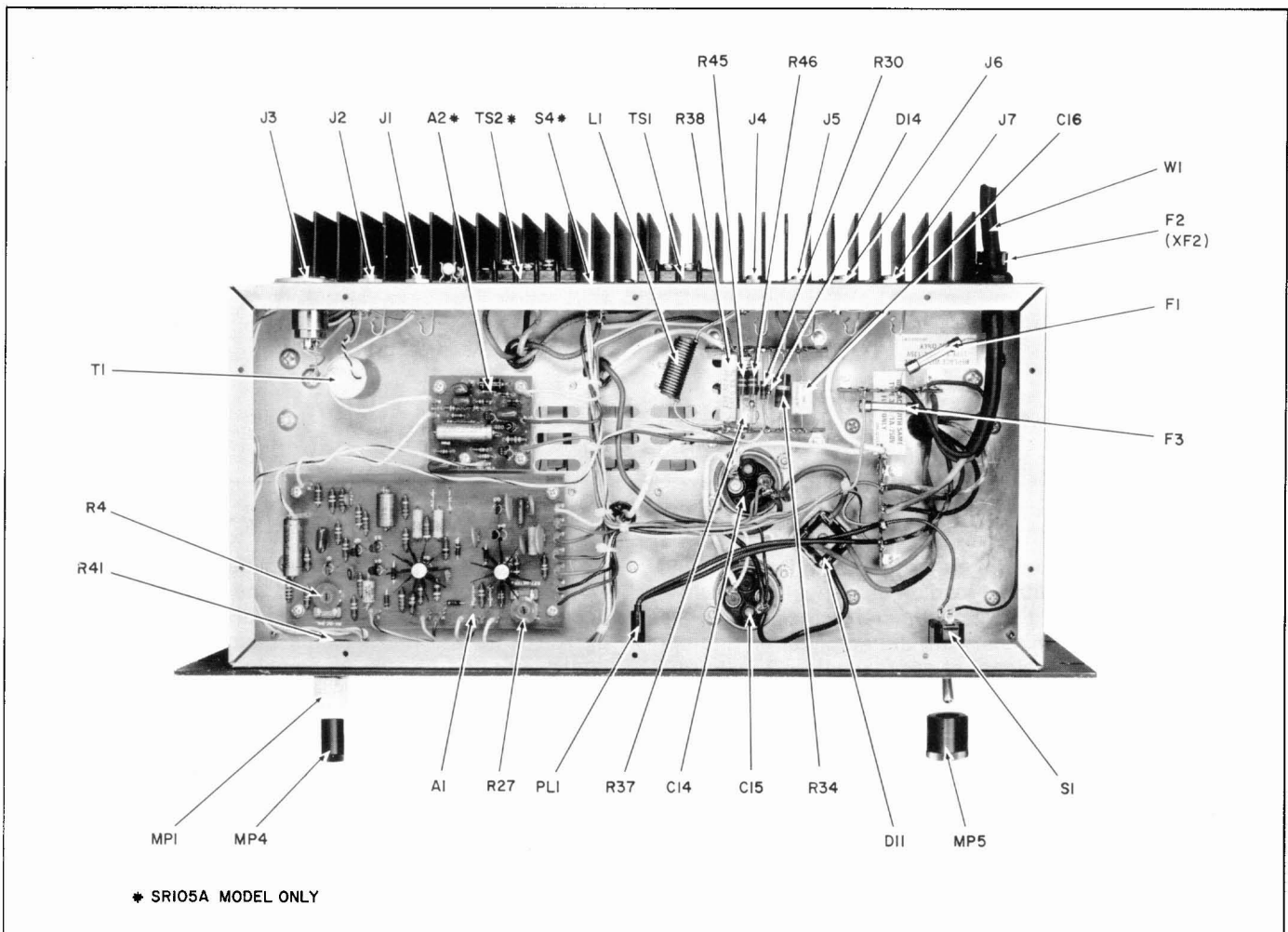

FIGURE 14. SR105 POWER AMPLIFIER BOTTOM VIEW, COVER REMOVED (SR105A MODEL SHOWN)

## OUTPUT TRANSISTORS

Output transistors Q9 through Q12 (Figure 13, Page 13) are located on the black, finned heat sinks. The replacement procedure is the same as that used for driver transistors Q7 and Q8.

NOTE: Output transistors Q9 through Q12 must be matched for current gain. When replacing output transistors, be sure to replace with devices which have the same gain and part number as the original transistors. Shure transistors have a letter suffix in the part number (i.e., 86A360A) which serves as a gain code. Transistors with the same part number and suffix letter have equal current gain.

## DIODES

Diodes D15 and D16 (Figure 13, Page 13) are located on the black, finned sinks with the output transistors. Special care is required to insulate these diodes from the heat sink while providing good heat transfer from sink to diode. Heat-shrinkable tubing or "spaghetti" should be placed over the diode and connecting leads; the diode should be securely clamped to the heat sink with the clamp provided.

## DIODE BRIDGE RECTIFIER

Silicon diode bridge rectifier D11 is mounted on the underside of the chassis as shown in Figure 14, Page 14. When replacing this component, apply Wakefield Type 120 thermal joint compound between the heat sink base of the rectifier and the chassis to provide good heat transfer to the chassis. Note that the base of the rectifier is provided with a locating pin. When installing the rectifier be sure to position it such that the locating pin fits into the hole provided for it in the chassis. The terminals are marked to indicate the ac connections to the power transformer and the (+) and (−) dc output connections to filter capacitors C14 and C15.

## CHECKING TRANSISTORS AND DIODES

Defective transistors and diodes may be located by use of a standard ohmmeter such as a Simpson Model 260. (Polarity of the ohmmeter must be verified before these checks are made.)

With a known diode orientation, measure the diode resistance in the forward and reverse directions. The lowest meter reading establishes the probe at the cathode end (schematic symbol arrow points to cathode) as the "minus" probe while the other probe is "plus." Some ohmmeters are not polarized in this manner with relation to "volts plus probe" and "volts minus probe." With the ohmmeter "plus" probe on the anode end of a diode and the "minus" probe on the cathode end, the ohmmeter should read approximately 2 kilohms or less. With the meter probes reversed, a reading of about 10 kilohms or more should occur. If either of these conditions is not met, the diode should be replaced.

When checking the bridge rectifier disconnect all leads to the assembly, noting the terminals to which they were connected. Check each diode leg of the bridge in the same manner as described previously for individual diodes. Refer to the preceding section, *Diode Bridge Rectifier*, for installation instructions if replacement is required.

To check transistors, the ohmmeter should be set to the 100- or 1,000-ohm scale. Small signal transistors (Q1 through Q6, Q13, Q14, Q201 through Q203) must be removed from the circuit before testing. Transistors mounted

with screws (Q7 through Q12) may be tested in place; however, the base and emitter leads to these transistors must be removed.

If all conditions in the following table are met, the transistors may be considered free of any major defect; if any of the following conditions are not met, the transistor should be replaced. See *Notes to Circuit Diagram* (Figure 20, Page 23) for transistor terminal codes.

| Ohmmeter Connections |              | Ohmmeter Reading |                |
|----------------------|--------------|------------------|----------------|
| "Plus" Lead          | "Minus" Lead | NPN Transistor   | PNP Transistor |
| Collector            | Emitter      | High             | High           |
| Emitter              | Collector    | High             | High           |
| Collector            | Base         | High             | Low            |
| Emitter              | Base         | —                | Low            |
| Base                 | Collector    | Low              | High           |
| Base                 | Emitter      | Low              | —              |

## SR105B AMPLIFIER CONVERSION FOR 70-VOLT OUTPUT

If it becomes necessary to equip a Model SR105B Power Amplifier for 70-volt output (distributed speaker) operation in addition to the existing 28-volt direct output, the conversion may be accomplished using the parts and procedures described below. The required parts may be ordered through a local Shure Franchised Dealer or directly from the Shure Factory. No modifications to the metal chassis or front panel are required.

### WARNING

This conversion should only be performed by qualified service personnel or the Shure Factory Service Department.

Once the conversion is performed, the Amplifier is identical to the SR105A Amplifier and all instructions and diagrams pertaining to the SR105A Amplifier apply.

The following parts, materials and tools are required to perform the 70-volt conversion (NOTE: Figure 15, Page 16 shows the electrical circuitry involved. Reference to the SR105A Amplifier Circuit Diagram, Figure 21, Page 25, will aid in understanding the circuit modifications.)

Remove the line cord from the ac outlet and remove all input and output cables. Remove the metal grille cover as described previously in this section. Remove the two locknuts securing the two lamp socket assemblies (see Figure 16, Page 17). Remove the lamp socket assemblies from the mounting studs and move them away from the studs to permit mounting of the 70-volt transformer. Place the transformer over the four mounting studs, orienting the transformer leads toward the center of the Amplifier chassis. Replace the lamp socket assemblies, orienting them as shown in Figure 16, and secure the transformer using the two locknuts previously removed and the two supplied with the transformer. Pass the transformer leads through the unused grommet nearest the rear of the Amplifier chassis.

Turn the Amplifier upside-down and remove the chassis bottom plate as described previously in this section. Remove the rear-panel 70-volt Conversion Cover (marked SHURE MODEL SR105B) (MP6) by removing the four screws securing it to the chassis. Mount the terminal strip

### SR105B AMPLIFIER CONVERSION

| PARTS |                |  | MATERIALS |   | TOOLS   |
|-------|----------------|--|-----------|---|---|
| Qty.  | Shure Part No. | Description                            | Qty.      | Description   | Description   |
| 1     | 51A244         | Transformer, 70V Output (T3)           | 2         | Locknuts, 10-32*  | Pliers, Diagonal, or Wire Stripper                          |
| 1     | 55C131         | Switch, Slide, DPDT (S4)               | 2         | Machine Screws, Phillips Round Head, 4-40 x 3/16"             | Pliers, Long-nose<br>Screwdriver                            |
| 1     | 56A204         | Terminal Strip, 3-Screw-Terminal (TS2) | 4         | Machine Screws, Phillips Head, 6-32 x 3/8"                    | Screwdriver, Phillips Head                                  |
| 1     | 90A2038        | Filter Circuit Board Assembly (A2)     | 4         | Machine Screws, Phillips Head, 6-32 x 1/4"***                 | Soldering Iron, Low Wattage<br>Wrench, Open-End, Adjustable |
|       |                |  | —         | Wire, Hookup, 16 Gauge AWG, Stranded Copper, Vinyl Insulation |   |
|       |                |  | —         | Wire, Hookup, 20 Gauge AWG, Stranded Copper, Vinyl Insulation |   |
|       |                |  | —         | Solder, Rosin-Core  |   |

\* Two locknuts are presently securing lamp socket assemblies; two more are required.  
 \*\*Four machine screws presently securing rear-panel 70-Volt Conversion Cover (53A1319) may be used.

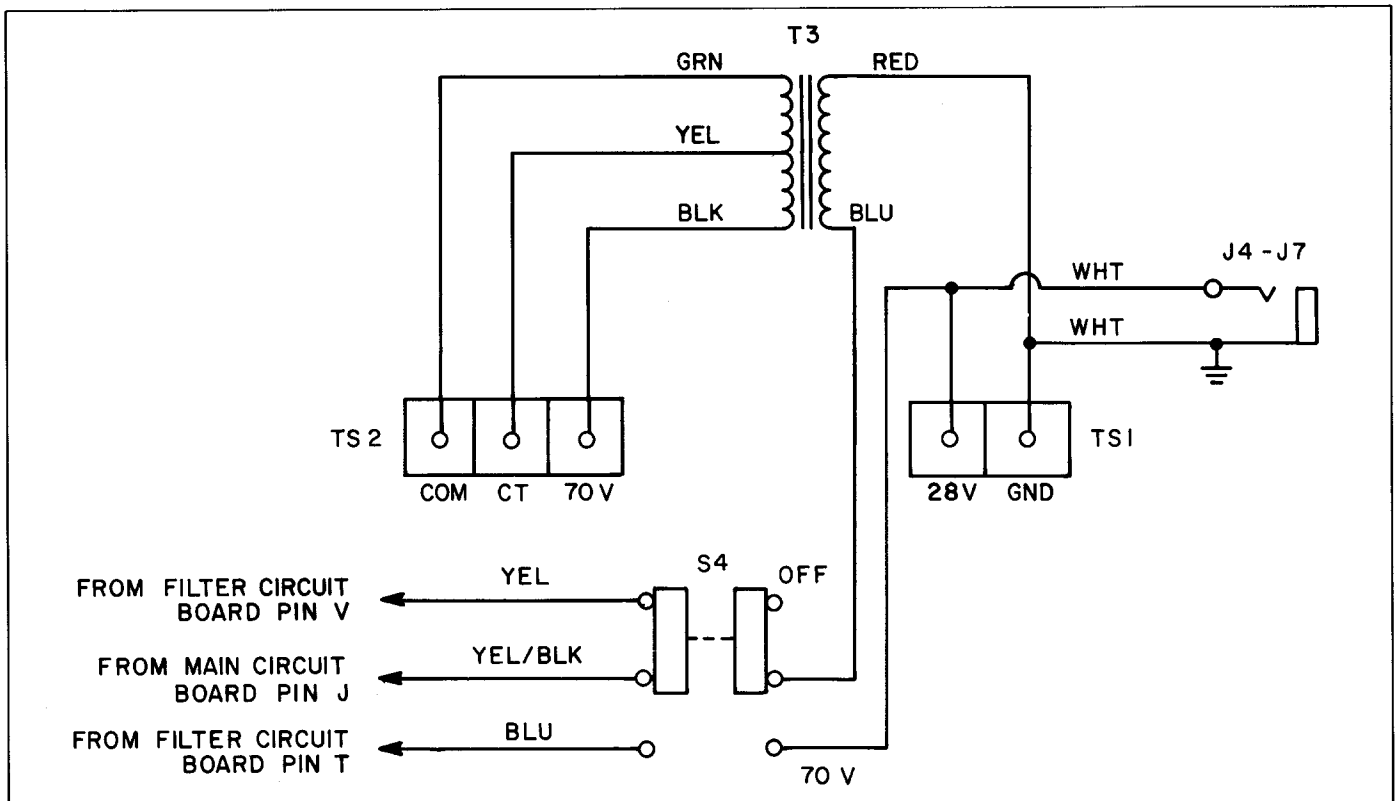
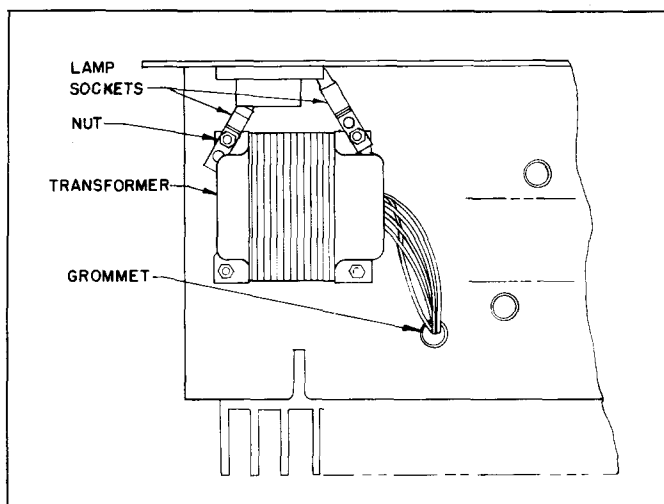

FIGURE 15. 70-VOLT CONVERSION: ADDED CIRCUITRY

in the space exposed by removal of the cover using four 6-32 x 3/8" Phillips head machine screws. Be sure to orient the screw contacts on the terminal strip in the same manner as the existing DIRECT OUTPUT terminal strip. Mount the slide switch next to the terminal strip in the space provided, using two Phillips round head 4-40 x 3/16" machine screws. Mount the Filter Circuit board next to the Main Circuit board using the four 6-32 x 1/4" Phillips head machine screws previously used to secure the cover.



**FIGURE 16. 70-VOLT CONVERSION:  
TRANSFORMER MOUNTING**

Remove the white lead from pin H on the Main Circuit board and fasten it to pin W on the Filter Circuit board. Remove the yellow/black lead from pin J on the Main Circuit board and fasten it to pin Y on the Filter Circuit board. Cut a length of 20-gauge hook-up wire (yellow/black preferred) and solder one end to pin J on the Main Circuit board.

**CAUTION**

Be careful not to damage board or adjacent components when soldering.

Run the soldered wire roughly parallel to the long edge of the Main Circuit board to the main wiring harness and along the harness to the 70-volt slide switch (S4). Solder the hook-up wire to the left center terminal (viewed from terminal side) of the switch (see Figure 17, Page 18). Cut a length of 20-gauge hook-up wire (white preferred) and solder one end to pin H on the Main Circuit board. Run the soldered wire twice around the two yellow/black wires (Main Circuit board J to switch S4, and Filter Circuit board Y to potentiometer R41) to form a loose shield. Solder the other end of the white wire to pin X on the Filter Circuit board.

Cut three lengths of 20-gauge hook-up wire and solder them to pins on the Filter Circuit board as follows: from pin

V (yellow preferred) to the upper left (viewed from terminal side) terminal of switch S4; from pin T (blue preferred) to the bottom left (viewed from terminal side) terminal of switch S4; and from pin S (red preferred) to the positive (red dot) terminal of capacitor C14.

Solder a length of 16-gauge hook-up wire (white preferred) from the 28V terminal of the 28-volt terminal strip (TS1) to the bottom right (viewed from terminal side) terminal of switch S4 (see Figure 17, Page 18). Solder transformer T3 leads coming out of the chassis grommet as follows:

| Transformer Lead Color   | Part Connection          | Part Terminal Designation |
|--------------------------|--------------------------|---------------------------|
| Red                      | 28V Terminal Strip (TS1) | GND                       |
| Black<br>Yellow<br>Green | 70V Terminal Strip (TS2) | 70V<br>CT<br>COM          |
| Blue                     | 70V Slide Switch (S4)    | Right Center Terminal     |

The Amplifier conversion is now complete. Perform a dc balance adjustment as described previously in this section. Reassemble the Amplifier and return it to service.

**SERVICE ILLUSTRATIONS**

The pages that follow contain parts locating drawings and an overall Circuit Diagram. The parts locating drawings are of the Main and Filter Circuit boards. Foil circuit paths are shown as shaded areas on the drawings. The Circuit Diagram shows all printed circuit board and chassis-mounted parts.

**GUARANTEE**

This Shure product is guaranteed in normal use to be free from electrical and mechanical defects for a period of one year from date of purchase. Please retain proof of purchase date. This guarantee includes all parts and labor. This guarantee is in lieu of any and all other guarantees or warranties, express or implied, and there shall be no recovery for any consequential or incidental damages.

**SHIPPING INSTRUCTIONS**

Carefully repack the unit and return it prepaid to:  
Shure Brothers Incorporated  
Attention: Service Department  
1501 West Shure Drive  
Arlington Heights, Illinois 60004

If outside the United States, return the unit to your dealer or Authorized Shure Service Center for repair. The unit will be returned to you prepaid.

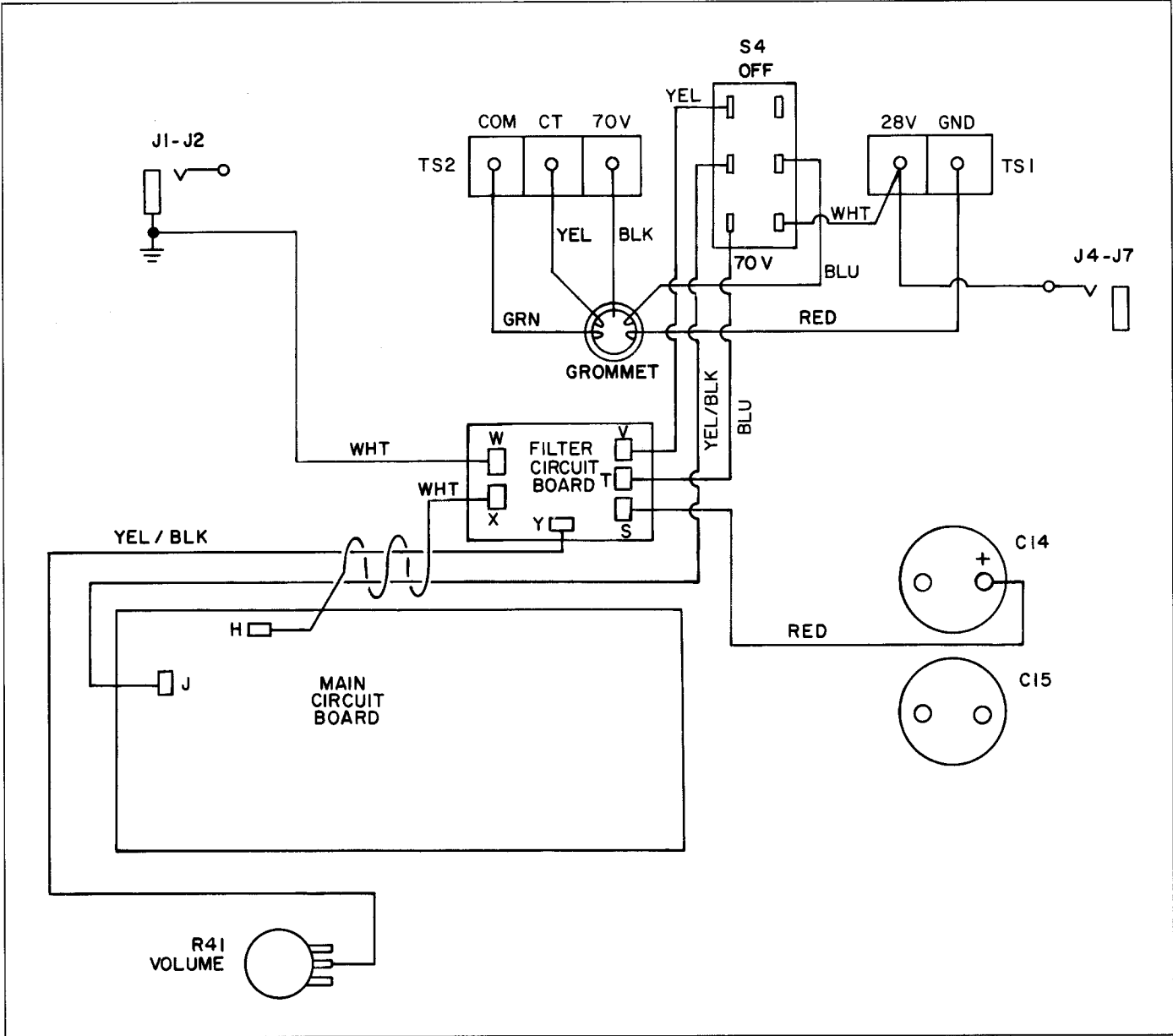

FIGURE 17. 70-VOLT CONVERSION: INTERNAL WIRING

# SR105 Power Amplifier

## REPLACEMENT PARTS LIST

**NOTE:** The commercial alternates shown in the following list are not necessarily equivalent parts, but are electrically and mechanically similar, and may be used if direct factory replacements are not immediately available. To maintain highest possible performance and reliability, Shure Factory Replacement Parts should be used.

| Reference Designation                       | Replacement Kit. No.* | Replacement Kit Consists Of: |          |  | Commercial Alternate             |
|---|-----------------------|------------------------------|----------|--|----------------------------------|
|   |                       | Qty.                         | Part No. | Description  |                                  |
| <b>CHASSIS-MOUNTED PARTS AND ASSEMBLIES</b> |                       |                              |          |  |                                  |
| A1  | —                     | —                            | 90A1865  | Main Circuit Board Assembly  | None                             |
| A2  | —                     | —                            | 90A2038  | Filter Circuit Board Assembly (SR105A only)  | None                             |
| C14, C15                                    | —                     | —                            | 86A639   | Capacitor, Electrolytic, 4000 $\mu$ F, 60V   | Sprague<br>36D252F075AC2A        |
| C16   | —                     | —                            | 50RB104B | Capacitor, .1 $\mu$ F, 400V  | CDE 4P1-10                       |
| D11   | —                     | —                            | 86A640   | Silicon Bridge Rectifier, 200V, 25A  | Varo VT200/T                     |
| D12, D13                                    | RKC46                 | 4                            | 86A406   | Diode, Silicon, 200V, 3A   | Motorola 1N4721                  |
| D14-D16                                     | RKC50                 | 2                            | 86A410   | Diode, Silicon, 100V, 1/2 A  | Motorola 1N4002                  |
| F1  | —                     | —                            | 90H2281  | Fuse, Ac, 3AG-8A, 125V (Wired-in)  | Littelfuse 318008                |
| F2  | RKC62                 | 5                            | 80A160   | Fuse, Ac, 3AG-5A   | Littelfuse 312005                |
| F3  | —                     | —                            | 90G2281  | Fuse, Dc, 3AG-1A (Wired-in)  | Littelfuse 318001                |
| J1, J2,<br>J4-J7                            | RKC68                 | 1                            | 95B446   | Connector, Phone Jack, 2-Conductor, Open Circuit, DIRECT OUTPUT (4) and UNBAL. PARALLELED HIGH IMPEDANCE (2) | Switchcraft 11                   |
| J3  | RKC83                 | 2                            | 95A482   | Connector, Female, 3-Pin Audio, BALANCED BRIDGING  | Switchcraft C3F                  |
| L1  | —                     | —                            | 95A596   | Choke Coil, 4.9 $\mu$ H  | J. W. Miller 5219                |
| M1  | —                     | —                            | 95A593   | Meter, Indicating, % OUTPUT VOLTAGE  | None                             |
| MP1   | —                     | —                            | 90A1786  | Knob Assembly, VOLUME  | None                             |
| MP2   | —                     | —                            | 39A425   | Nameplate, Front-Panel   | None                             |
| MP3   | —                     | —                            | 31A1145A | Cover, Potentiometer, VOLUME   | None                             |
| MP4   | —                     | —                            | 31A1144A | Cover, Switch, POWER   | None                             |
| MP5   | —                     | —                            | 53A1319  | Cover Plate, 70-volt Conversion (SR105B only)  | None                             |
| MP6   | —                     | —                            | 53A1239A | Grille, Cover  | None                             |
| PL1   | —                     | —                            | 90E2600  | Lamp, Indicator, Neon  | Leecraft 36N1311-7               |
| PL2, PL3                                    | RKC7                  | 4                            | 95A466   | Lamp, Indicator  | Chicago Miniature Lamp 47; GE 47 |
| Q7  | —                     | —                            | 86A361   | Transistor, Silicon, NPN, Driver   | RCA 2N6263                       |

\*Parts listed as RKC Kits should be ordered by that kit number. Any orders received for piece parts where RKC Kit number is shown will be shipped in RKC quantities.

## REPLACEMENT PARTS FOR SR105 POWER AMPLIFIER

| Reference Designation | Replacement Kit. No.* | Replacement Kit Consists Of: |          |   | Commercial Alternate       |
|-----------------------|-----------------------|------------------------------|----------|---|----------------------------|
|                       |                       | Qty.                         | Part No. | Description   |                            |
| Q8                    | —                     | —                            | 86A362   | Transistor, Silicon, PNP, Driver, BVCEO 120V min.   | Motorola 2N3741 (Selected) |
| Q9-Q12                | —                     | —                            | 86A360   | Transistor, Silicon, NPN                            | RCA 2N3773                 |
| R35-R40               | —                     | —                            | 45EB439D | Resistor, Fixed, 0.43 ohms, 5%, 7W                  | None                       |
| R41                   | —                     | —                            | 46A041   | Potentiometer, 50K, VOLUME                          | None                       |
| R43, R44              | —                     | —                            | 45CB758C | Resistor, Fixed, 7.5 ohms, 5%, 1W                   | Allen-Bradley GB           |
| R45, R46              | —                     | —                            | 45CB308C | Resistor, Fixed, 3.0 ohms, 5%, 1W                   | Allen-Bradley GB           |
| S1                    | —                     | —                            | 55A96    | Switch, Toggle, SPST, POWER                         | Cutler-Hammer 7510K12      |
| S2, S3                | RKC37                 | 1                            | 95A551   | Thermostat, SPST                                    | None                       |
| S4                    | —                     | —                            | 55C131   | Switch, Slide, DPDT, 70V-OFF (SR105A only)          | None                       |
| T1                    | —                     | —                            | 90K2150  | Transformer Assembly, Balanced Input                | None                       |
| T2                    | —                     | —                            | 51A256   | Transformer, Power                                  | None                       |
| T3                    | —                     | —                            | 51A244   | Transformer, 70V Output (SR105A only)               | None                       |
| TB1                   | —                     | —                            | 56A211   | Terminal Strip, 2-screw, DIRECT OUTPUT              | Cinch 2-141-Y              |
| TB2                   | —                     | —                            | 56A204   | Terminal Strip, 3-screw, 70V (SR105A only)          | Cinch 3-141-Y              |
| W1                    | —                     | —                            | 95A632   | Line Cord and 3-Conductor Ac Plug Assembly          | None                       |
| W2                    | —                     | —                            | 90A1522  | Cable and Plug Assembly, 6-Foot, with 2 Phone Plugs | None                       |
| XF1                   | —                     | —                            | 95A429   | Fuseholder, 3AG-5A                                  | Littelfuse 342014          |
| XPL1                  | —                     | —                            | 95A598   | Lampholder and Bracket Assembly                     | None                       |
| XPL2                  | —                     | —                            | 95A599   | Lampholder and Bracket Assembly, Nylon Sleeve       | None                       |

## MAIN CIRCUIT BOARD ASSEMBLY

|                  |       |   |         |   |   |
|------------------|-------|---|---------|---|---|
| C1               | —     | — | 86K628  | Capacitor, Electrolytic, 250 $\mu$ F, 16V | Sprague 30A-TE11645; Mallory MTA-250F15 |
| C2               | —     | — | 50KC224 | Capacitor, Film, .22 $\mu$ F, 100V        | CDE 1P22-10                             |
| C5               | —     | — | 86D630  | Capacitor, Electrolytic, 10 $\mu$ F, 10V  | Sprague 30D-TE1128; CDE NLW-10-16       |
| C6               | —     | — | 86H628  | Capacitor, Electrolytic, 80 $\mu$ F, 25V  | Sprague 30D-TE1210; CDE NLW-100-25      |
| D1               | RKC23 | 1 | 86A409  | Zener Diode, Silicon, 2.6V                | Motorola 1N4729A                        |
| D2, D3, D6<br>D7 | RKC21 | 4 | 86A404  | Silicon Rectifier, 100V, 1/2 A            | Motorola 1N4002                         |
| D4, D5           | —     | — | 86A415  | Diode, Silicon, Computer, 75V             | TI or GE 1N4148                         |
| D8, D9           | RKC19 | 4 | 86A405  | Diode, Germanium, 30V                     | RCA 1N48, 1N60                          |

\*Parts listed as RKC Kits should be ordered by that kit number. Any orders received for piece parts where RKC Kit number is shown will be shipped in RKC quantities.

## REPLACEMENT PARTS FOR SR105 POWER AMPLIFIER

| Reference Designation | Replacement Kit. No.* | Replacement Kit Consists Of: |          |  | Commercial Alternate          |
|-----------------------|-----------------------|------------------------------|----------|--|-------------------------------|
|                       |                       | Qty.                         | Part No. | Description                                  |                               |
| Q1                    | RKC9                  | 4                            | 86A349   | Transistor, Silicon, NPN                     | Motorola 2N5088;<br>TI 2N3711 |
| Q2-Q4                 | —                     | —                            | 86A355   | Transistor, Silicon, NPN                     | Motorola MPS-A06              |
| Q5                    | —                     | —                            | 86A354   | Transistor, Silicon, Power, PNP              | Motorola 2N5680               |
| Q6                    | RKC53                 | 1                            | 86A333   | Transistor, Silicon, NPN                     | Motorola 2N5682               |
| Q13                   | —                     | —                            | 86A363   | Transistor, Silicon, Power, NPN, VI Limiting | Motorola MPS-A20**            |
| Q14                   | —                     | —                            | 86A364   | Transistor, Silicon, PNP, VI Limiting        | Motorola MPS-A70**            |
| R4, R27               | —                     | —                            | 46A042   | Potentiometer, P.C. Bd. Mtg., 10K            | None                          |
| R17, R21              | —                     | —                            | 45F1301B | Resistor, Metal Film, 1.3k, 1%, 1/2 W        | IRC CEC-TO                    |
| R25                   | —                     | —                            | 45F6818B | Resistor, Metal Film, 68.1 ohms, 1%, 1/2 W   | IRC CEC-TO                    |
| R26                   | —                     | —                            | 45F6498B | Resistor, Metal Film, 64.9 ohms, 1%, 1/2 W   | IRC CEC-TO                    |

## FILTER BOARD ASSEMBLY (SR105A ONLY)

|            |      |   |         |  |  |
|------------|------|---|---------|--|--|
| C201       | —    | — | 50KB224 | Capacitor, Film, .22 $\mu$ F, 100V             | CDE 1P22-10  |
| C202, C203 | —    | — | 50KA104 | Capacitor, Film, .1 $\mu$ F, 100V, 5%          | Sprague<br>225P10491;<br>CDE 1P1-10                |
| C204       | —    | — | 86A630  | Capacitor, Electrolytic, 4.7 or 5 $\mu$ F, 35V | Sprague<br>30D-TE1303;<br>CDE NLW-5-50             |
| C205       | —    | — | 50KA124 | Capacitor, Film, .12 $\mu$ F, 100V, 5%         | None   |
| C206       | —    | — | 86K628  | Capacitor, Electrolytic, 250 $\mu$ F, 16V      | Sprague<br>30D-TE1164.5;<br>Mallory MTA-<br>250F15 |
| Q201, Q202 | RKC9 | 4 | 86A349  | Transistor, Silicon, NPN                       | Motorola 2N5088;<br>TI 2N3711                      |
| Q203       | —    | — | 86A348  | Transistor, Silicon, Low Power, PNP            | Motorola 2N5087                                    |

\*Parts listed as RKC Kits should be ordered by that kit number. Any orders received for piece parts where RKC Kit number is shown will be shipped in RKC quantities.  
 \*\*Use in emergency only. Select for high gain. May affect power output and reliability.

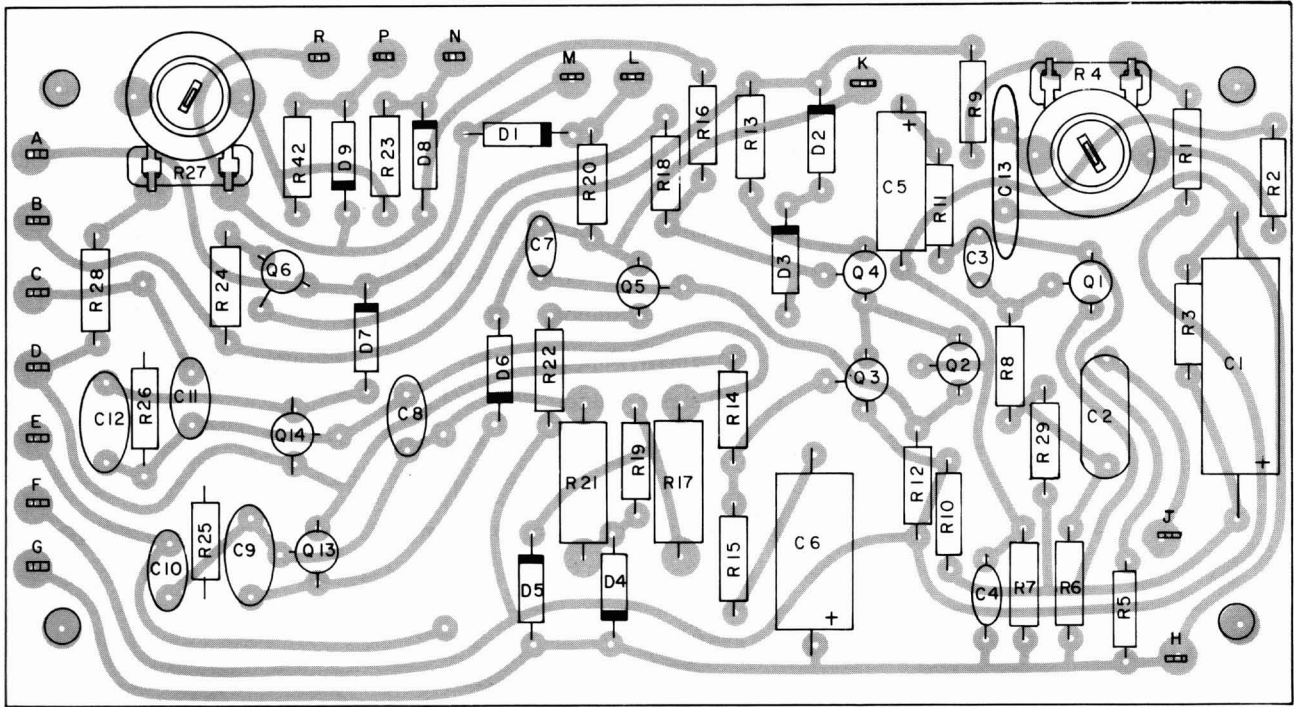

FIGURE 18. MAIN CIRCUIT BOARD PARTS LOCATION DIAGRAM

2259-10/594-7

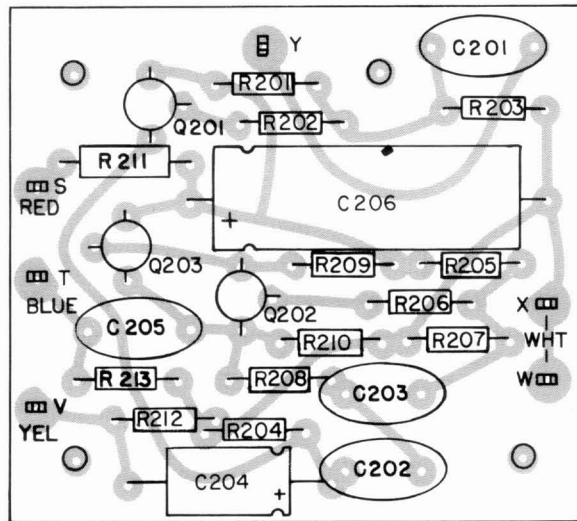

FIGURE 19. FILTER CIRCUIT BOARD PARTS LOCATION DIAGRAM

2038-2/525-2

# SR105 Power Amplifier

## NOTES TO CIRCUIT DIAGRAM

### GENERAL

Shure part numbers are not shown in the Parts List accompanying the Circuit Diagram (Figure 21, Page 25) if parts are readily available through local electronics parts suppliers. In these instances, the Circuit Diagram shows only the reference designation and value of the standard parts.

All capacitor values are shown in microfarads unless otherwise designated. All non-electrolytic capacitors are 100 working volts dc or more unless otherwise specified. Electrolytic capacitors are shown in microfarads x volts.

All resistor values are shown in ohms ( $k = 1000$ ). Resistors are 10% tolerance unless otherwise specified. Resistors are  $\frac{1}{2}$ -watt unless otherwise specified.

Transistor lead codes are as shown in Figure 20. Acceptable replacements are as shown in the Parts List.

The following ground symbols denote:

Chassis Ground  $\text{///}$   
 Circuit Ground  $\text{---}\perp$   
 Printed Circuit Board Ground  $\text{---}\downarrow$

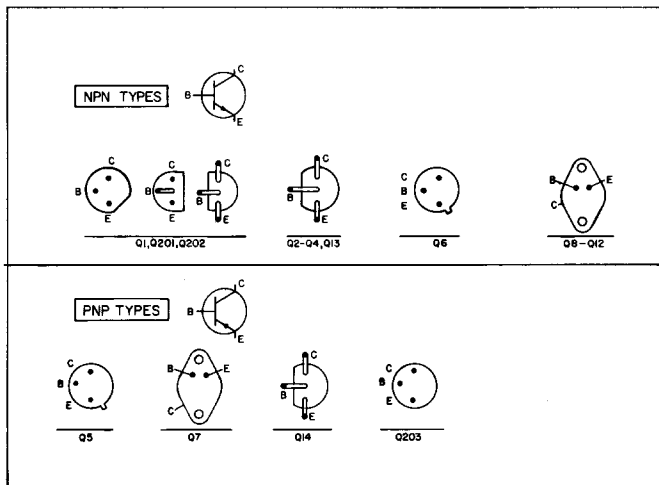

**FIGURE 20. TRANSISTOR LEAD CODES**

### TROUBLESHOOTING

A general troubleshooting process is as follows: If the Amplifier is completely "dead," check the ac power source, fuses, and power supply output (52.5V at pin F of Main Circuit board). If the indicator lamps are on but the output is distorted, low or not present, apply an input signal as described under *Ac Voltage Measurements* below, and

determine that the input and output voltages to each board assembly are correct. If an incorrect ac voltage is found at any board output, perform *Dc Voltage Measurements* on that board as described below to isolate the problem area.

### AC VOLTAGE MEASUREMENTS

The numbers within rectangular symbols  $\square$  on the Circuit Diagram denote the ac voltage at that point under the following test conditions:

1. Voltage measured with respect to chassis unless otherwise indicated.
2. Line voltage: 120V, 50/60 Hz.
3. Test signal of 0.3V, 1 kHz applied across connector J1.
4. Ac voltage measurements may vary  $\pm 20\%$  from values shown.
5. Measurements made with ac VTVM of 1 megohm or greater input impedance.
6. Four-ohm non-inductive 200-watt load across DIRECT OUTPUT Terminal Strip TS1 for direct output measurements or (SR105A only) 33-ohm non-inductive 150-watt load across 70-volt OUTPUT Terminal Strip TS2 (70V-COM) for 70-volt output measurements, but not both.
7. Volume Control set to maximum (10).
8. SR105A Only: 70V-OFF Switch set to OFF for all circuit measurements *except* 70-volt circuitry (Filter Circuit board and associated components). Filter Circuit board rolls off the low frequencies; amplifier output should be  $-3 \pm 1$  dB at 30 Hz referenced to 1 kHz and  $-12 \pm 3$  dB at 20 Hz.

### DC VOLTAGE MEASUREMENTS

The numbers within elliptical symbols  $\circ$  on the circuit diagram denote the dc voltage at that point under the following test conditions:

1. Voltages measured with respect to chassis unless otherwise indicated.
2. Line voltage: 120V, 50/60 Hz.
3. No input signal applied.
4. Dc voltage measurements may vary  $\pm 20\%$  from values shown.
5. Measurements made with VTVM of 11 megohms or greater input impedance.

### RESISTANCE MEASUREMENTS

With the ac line cord disconnected from the ac source and the POWER ON-OFF Switch in the OFF position, the following ohmmeter measurements may be made:

1. Transformers may be checked for continuity of each winding.
2. To test transistors and diodes, see Page 15.



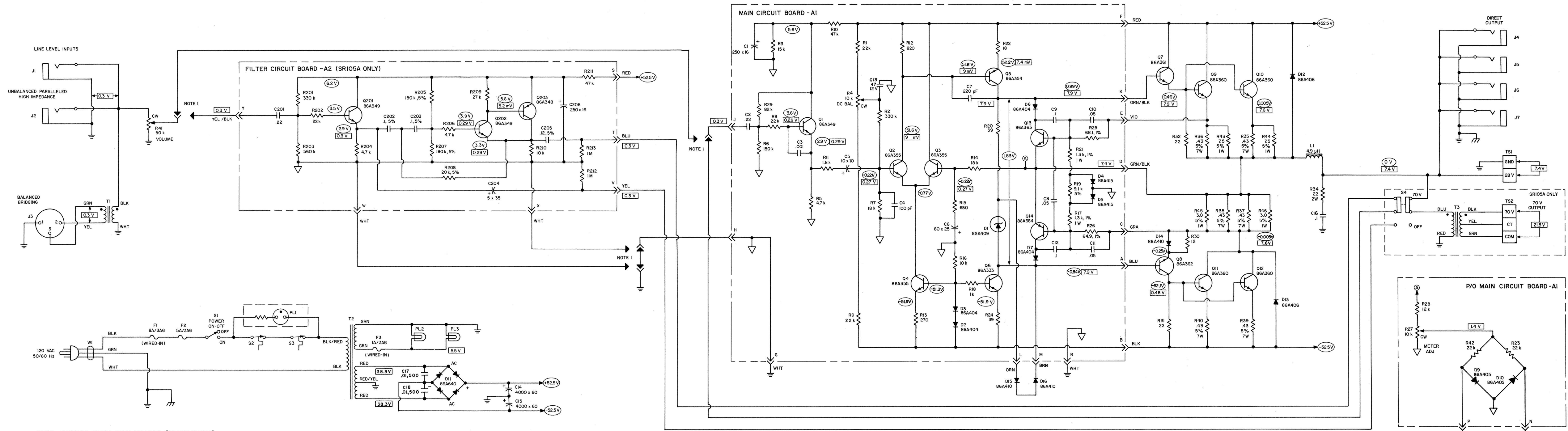

NOTE 1: DIFFERENCES BETWEEN SR105A AND SR105B: "STRAIGHT-THROUGH" WIRING SHOWS SR105B CIRCUITS; SR105A CIRCUITS INCLUDE ASSEMBLY A2, SWITCH S4, TRANSFORMER T3, AND TERMINAL STRIP TS2.

| ISSUE | SR105A REFERENCE NO. | SR105B REFERENCE NO. | DESCRIPTION                |
|-------|----------------------|----------------------|----------------------------|
| 1     | 90A2043-II-2         | 90B2043-II-1         | ---                        |
| 2     | 90A2043-II-4         | 90B2043-II-3         | R1, R9 WERE 12k, C13 ADDED |
| 3     | 90A2043-II-7         | 90B2043-II           | C17, C18 ADDED             |

FIGURE 21. SR105 POWER AMPLIFIER CIRCUIT DIAGRAM



# SR105 Power Amplifier

## CONDENSED OPERATING INSTRUCTIONS

### DIRECT SPEAKER OUTPUT (MODELS SR105A and SR105B)

1. With line cord unplugged, install Amplifier in rack or carrying case, allowing adequate ventilation.
2. Connect speakers to DIRECT OUTPUT Jacks and/or Terminal Strip.
3. Connect console or mixer output to UNBALANCED PARALLELED HIGH IMPEDANCE Input Jack. For cable length greater than 15m (50 ft), use 600-ohm balanced line into BALANCED BRIDGING Input Jack (three-pin).
4. Connect additional power amplifiers or auxiliary equipment as required.
5. Connect line cord to ac source.
6. Turn on POWER ON-OFF Switch and adjust VOLUME Control to desired level.

### CONSTANT VOLTAGE 70-VOLT SPEAKER OUTPUT (MODEL SR105A ONLY)

1. Install Amplifier and connect auxiliary equipment as for Direct Speaker Output operation.
2. Connect speakers to 70V OUTPUT Terminal Strip.
3. Connect console or mixer output to UNBALANCED PARALLELED HIGH IMPEDANCE Input Jack. For cable length greater than 15m (50 ft), use 600-ohm balanced line into BALANCED BRIDGING Input Jack (three-pin).
4. Turn 70V-OFF Switch to 70V.
5. Connect line cord to ac source.
6. Turn POWER ON-OFF Switch on and adjust VOLUME Control.

# SR105 Power Amplifier

## ARCHITECTS' AND ENGINEERS' SPECIFICATIONS

### SR105A POWER AMPLIFIER

The Amplifier shall be a rack-mounted, 120-volt, 50/60 Hz line-operated, all silicon transistor, 200-watt power amplifier.

The Amplifier shall deliver 200 watts rms continuous output power at 1 kHz into a 4-ohm load with less than 2% distortion (DIRECT OUTPUT), and 150 watts rms continuous output power with less than 3% distortion to a 33-ohm load (70-VOLT OUTPUT). Typical frequency response shall be 20 to 20,000 Hz  $\pm 1.5$  dB with a 4-ohm load (DIRECT OUTPUT) and 50 to 15,000 Hz  $\pm 2$  db with a 33-ohm load (70-VOLT OUTPUT).

The Amplifier shall have four phone jacks and one terminal strip speaker output for 25-volt output, plus one terminal strip for 70-volt output.

The Amplifier shall have built-in circuitry to protect the Amplifier from open circuit, short circuit, or mismatched output loads, by using current-limiting, voltage-limiting, temperature-sensing diodes, and thermal-sensing switches.

The automatic thermal-sensing switches and temperature-sensing diodes shall be mounted on the output transistor heat sinks to protect the Amplifier from overheating due to short circuits, mismatched output loads, or high ambient temperatures. The thermal switches shall automatically shut off the ac power in the event of overheating and shall automatically restore the ac power when the Amplifier has reached a safe operating temperature. When the Amplifier has thermally cycled off, a THERMAL OVERLOAD indicator shall light.

The INPUTS shall accept signals from high impedance sources. The balanced bridging input shall be a professional three-pin audio connector. The unbalanced input connectors shall be standard ¼-inch phone jacks.

The Amplifier shall have an independent VOLUME control, POWER ON-OFF Switch and 70-VOLT/OFF Switch to activate the 70-volt output transformer.

The Amplifier shall be enclosed in a metal, rack-mounting cabinet, with a scuff-resistant vinyl-covered front panel. The dimensions shall be 178 mm x 483 mm x 270 mm (7 inches in height, 19 inches in width, and 10 $\frac{5}{8}$  inches in depth). The weight shall be no more than 15.66 kg (34 pounds 8 ounces).

The Amplifier shall have a maximum voltage gain of 27  $\pm 2$  dB at 1 kHz, and a nominal input sensitivity of 1.2 volts for 200 watts rms output power to a 4-ohm load. Seventy-volt circuitry voltage gain shall be 35  $\pm 3.5$  dB at 1 kHz, and a 1.2-volt nominal input sensitivity for 150 watts rms output power to a 33-ohm load.

The Amplifier hum and noise shall be at least 80 dB below 200 watts rms output with a 4-ohm resistive load.

The Amplifier shall contain 4 silicon output transistors, 13 other silicon transistors, and 1 zener diode.

Any Amplifier not meeting all of the above specifications shall be deemed unacceptable under this specification. The Amplifier shall be a Shure Model SR105A.

### SR105B POWER AMPLIFIER

The Amplifier shall be a rack-mountable, 120-volt, 50/60 Hz line-operated, all silicon transistor, 200-watt power amplifier.

The Amplifier shall deliver 200 watts rms continuous power at 1 kHz into a 4-ohm load with less than 2% distortion. Typical frequency response shall be 20 to 20,000 Hz  $\pm 1.5$  dB with a 4-ohm load.

The Amplifier shall have four phone jacks and one terminal strip speaker output for 25-volt output.

The Amplifier shall have built-in circuitry to protect the Amplifier from open circuit, short circuit, or mismatched output loads, by using current-limiting, voltage-limiting, temperature-sensing diodes, and thermal-sensing switches.

The automatic thermal-sensing switches and temperature-sensing diodes shall be mounted on the output transistor heat sinks to protect the Amplifier from overheating due to short circuits, mismatched output loads, or high ambient temperatures. The thermal switches shall automatically shut off the ac power in the event of overheating and shall automatically restore the ac power when the Amplifier has reached a safe operating temperature. When the Amplifier has thermally cycled off, a THERMAL OVERLOAD indicator shall light.

The INPUTS shall accept signals from high impedance sources. The balanced bridging input shall be a professional three-pin audio connector. The unbalanced input connectors shall be standard ¼-inch phone jacks.

The Amplifier shall have an independent VOLUME Control and POWER ON-OFF Switch. The Amplifier shall be enclosed in a metal, rack-mounting cabinet, with a scuff-resistant vinyl-covered front panel. The dimensions shall be 178 mm x 483 mm x 270 mm (7 inches in height, 19 inches in width, and 10<sup>5</sup>/<sub>8</sub> inches in depth). The weight shall be no more than 12.23 kg (27 pounds).

The Amplifier shall have a maximum voltage gain of  $27 \pm 2$  dB at 1 kHz, and a nominal input sensitivity of 1.2 volts for 200 watts rms output power to a 4-ohm load.

The Amplifier hum and noise shall be at least 80 dB below 200 watts rms output with a 4-ohm resistive load.

The Amplifier shall contain 4 silicon output transistors, 10 other silicon transistors, and 1 zener diode.

Any Amplifier not meeting all of the above specifications shall be deemed unacceptable under this specification. The Amplifier shall be a Shure Model SR105B.