

# SERVICE MANUAL

SKANTIC

LUXOR

Maj  
May 1980  
Mai

Denna serviceanvisning gäller endast kassettdelen. I övrigt hänvisas till serviceanvisning R3E-2.

This service manual only applies to the cassette section. For other information please refer to service manual R3E-2ET.

Diese Serviceanweisung gilt nur für das Cassetten-Teil. Im übrigen gilt die Serviceanweisung R3E-2ET.



TYPE  
150 3093

## DATA

Frekvensområde	Frequency range	Übertragungsbereich	Fuji FX1 20 - 14.000 Hz CrO <sub>2</sub> Super 20 - 15.000 Hz
Distorsion vid 1000 Hz	Distortion at 1000 Hz	Klirrfaktor bei 1000 Hz	1,0 %
Störavstånd	S/N ratio	Störabstand	Fuji FX1 64 dB CrO <sub>2</sub> Super 63 dB
Överhörning	Channel separation	Übersprechen	≥ 40 dB
Raderdämpning vid 1000 Hz	Erase efficiency at 1000 Hz	Löschdämpfung bei 1000 Hz	≥ 60 dB
Svajning	Wow and flutter	Tonhörschwankung	+ 0,20 % (DIN)
Bandhastighet	Tape speed	Bandgeschwindigkeit	4,75 cm/s
Hastighetsavvikelse	Speed deviation	Abweichung der Bandgeschwindigkeit	+ 1,0 %
Snabbspolningshastighet	Fast wind	Umspulzeit	90 s (C-60)

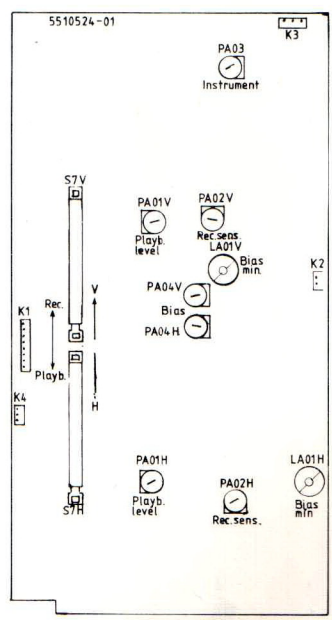
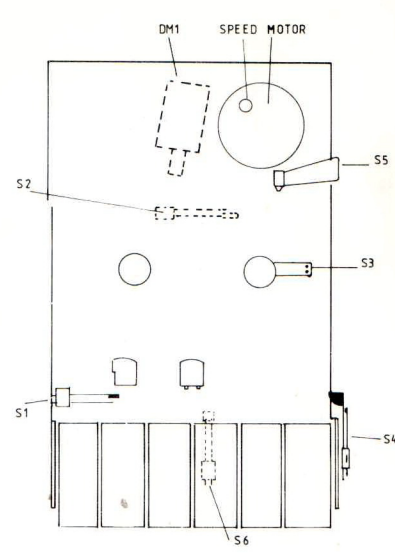
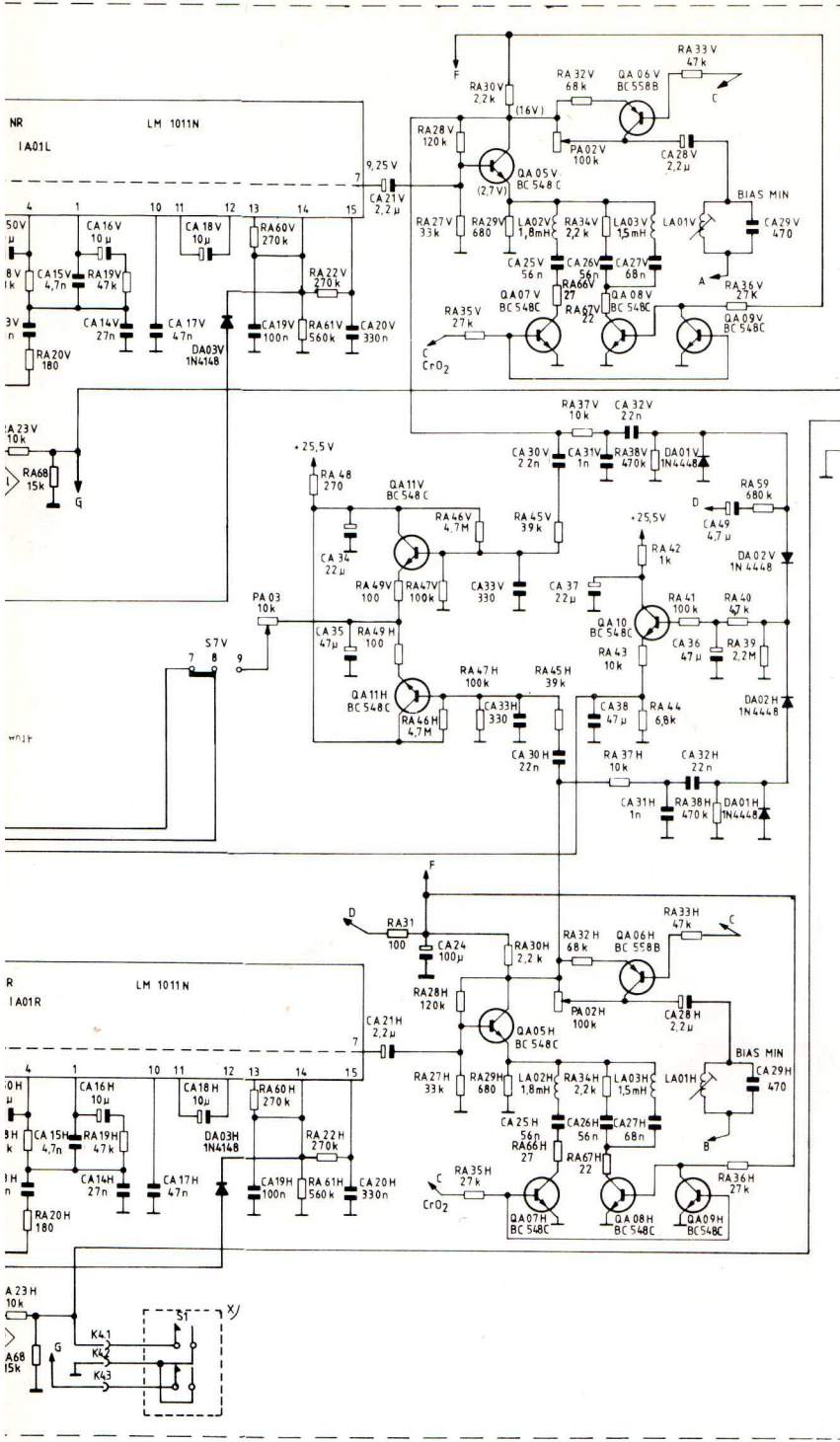

AUTO-STOP SOLENOID

Placerad utanför kretskortet  
Placed outside PC board

01	Pilot-Bias	59 40077-01
11	Bias	59 81669-01
12	1,8 mH	59 00226-01
13	1,5 mH	59 00224-01
14	Bias osc.	59 00323-01
11,02	100 μH	59 00230-01
	Rec/PB	56 30044-01

DA01,02	1N4448	63 40054-01
03	1N4148	63 08824-01
DB01,02	1N4448	63 40054-01
DC01,02	1N4001	63 40004-01
03	BZX61C13	63 40064-01
04-06	1N4148	63 08824-01
IA01	LM 1011N	64 90037-01

QA01,02	BC 413C	63 10051-01
03,04	BC 558B	63 10041-01
06		
05,07-11	BC 548C	63 10021-01
12,13	BC 547B	63 10011-01
QB01,02	BC 413C	63 10051-01
TC01	LUX 100	63 20026-01
02	BC 558B	63 10041-01
03	BC 547B	63 10011-01
04	BC 337B	63 10017-01
PA01	47 kΩ	61 17705-01
02,04	100 kΩ	61 17706-01
03	10 kΩ	61 17961-01



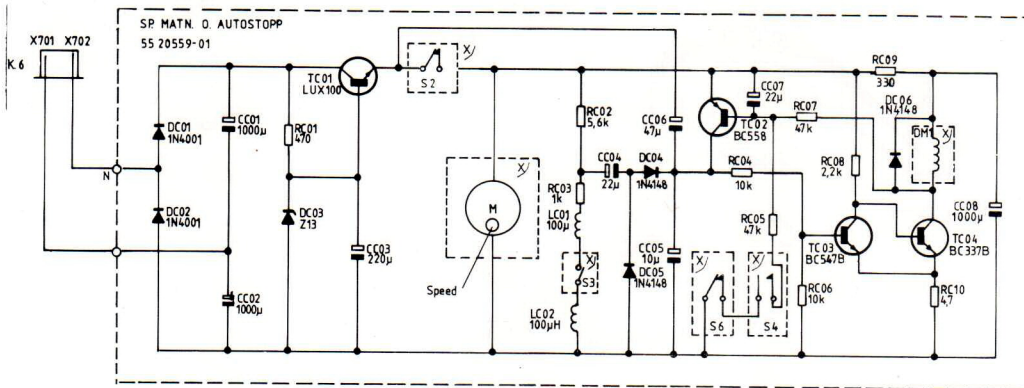
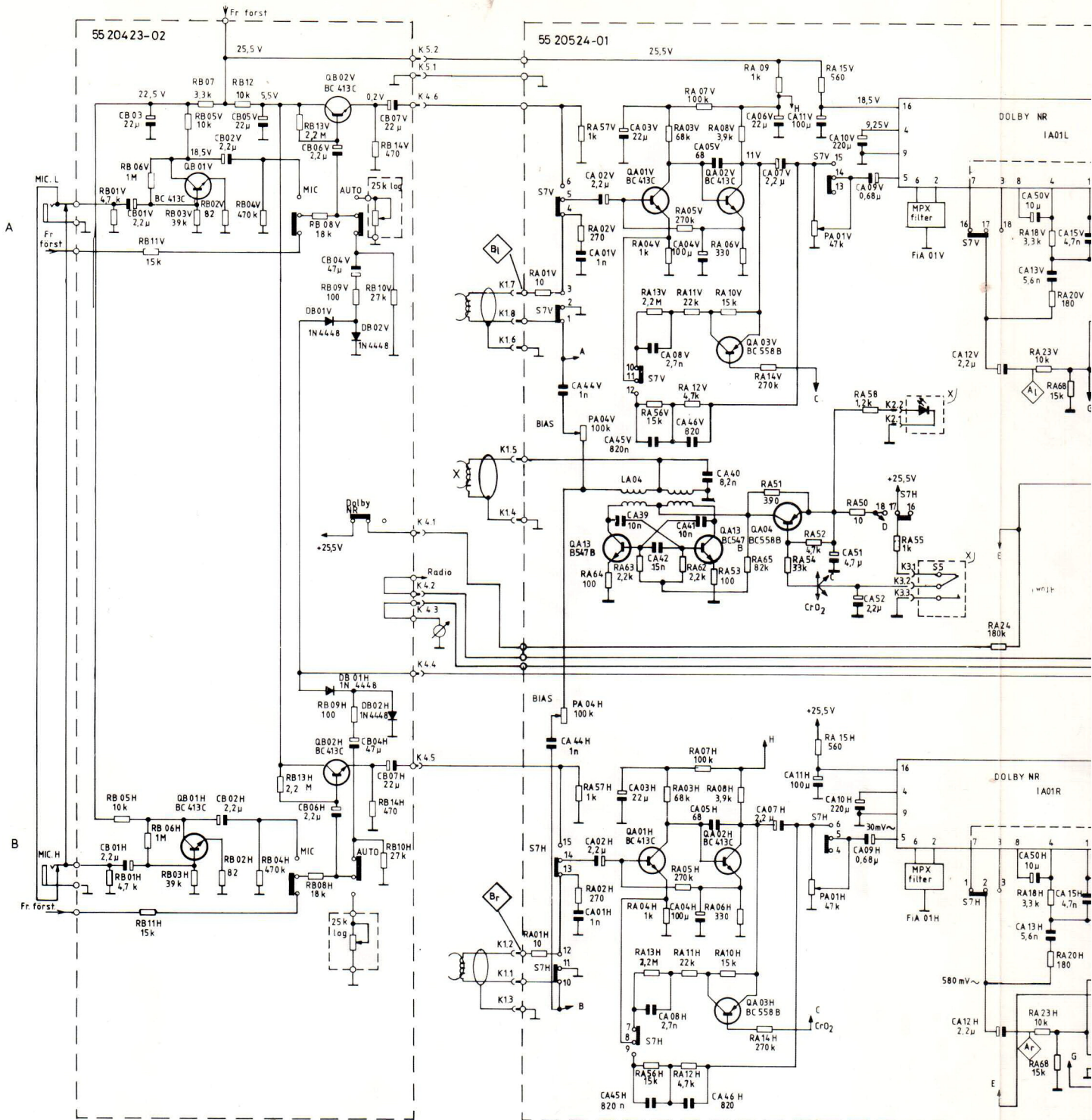

- S1 MUTING-SWITCH
- S2 MOTOR-SWITCH
- S3 ROTATION-SWITCH
- S4 PAUS-SWITCH
- S5 CrO<sub>2</sub>-SWITCH
- S6 PLAY-SWITCH
- S7 PLAYB/REC-SWITCH

DM1 AUTO-STO

FIA01

LA01

02

03

04

LC01,02

S7

R