

SERVICE MANUAL

SKANTIC

LUXOR

Juni 1980
June



TYPE 110 9107
110 9197



AC 220 V, 50 Hz
DC 9 V (6×R20)



2×2.3 W
2 st 12 cm



FM: 87—105 MHz
LV: 150—300 kHz
MV: 525—1605 kHz
SV: 6—18 MHz



LCD Quartz
DC 1.5 V

Känslighet
Sensitivity
Empfindlichkeit

FM mono/stereo 7/18 μ V
LV 1200 μ V/m
MV 1000 μ V/m
SV 35 μ V/m

Svaj
Wow and flutter ± 0.35 %
Tonhöenschwankung

Frekvensområde
Frequency response 100—8000 Hz
Frequenzbereich

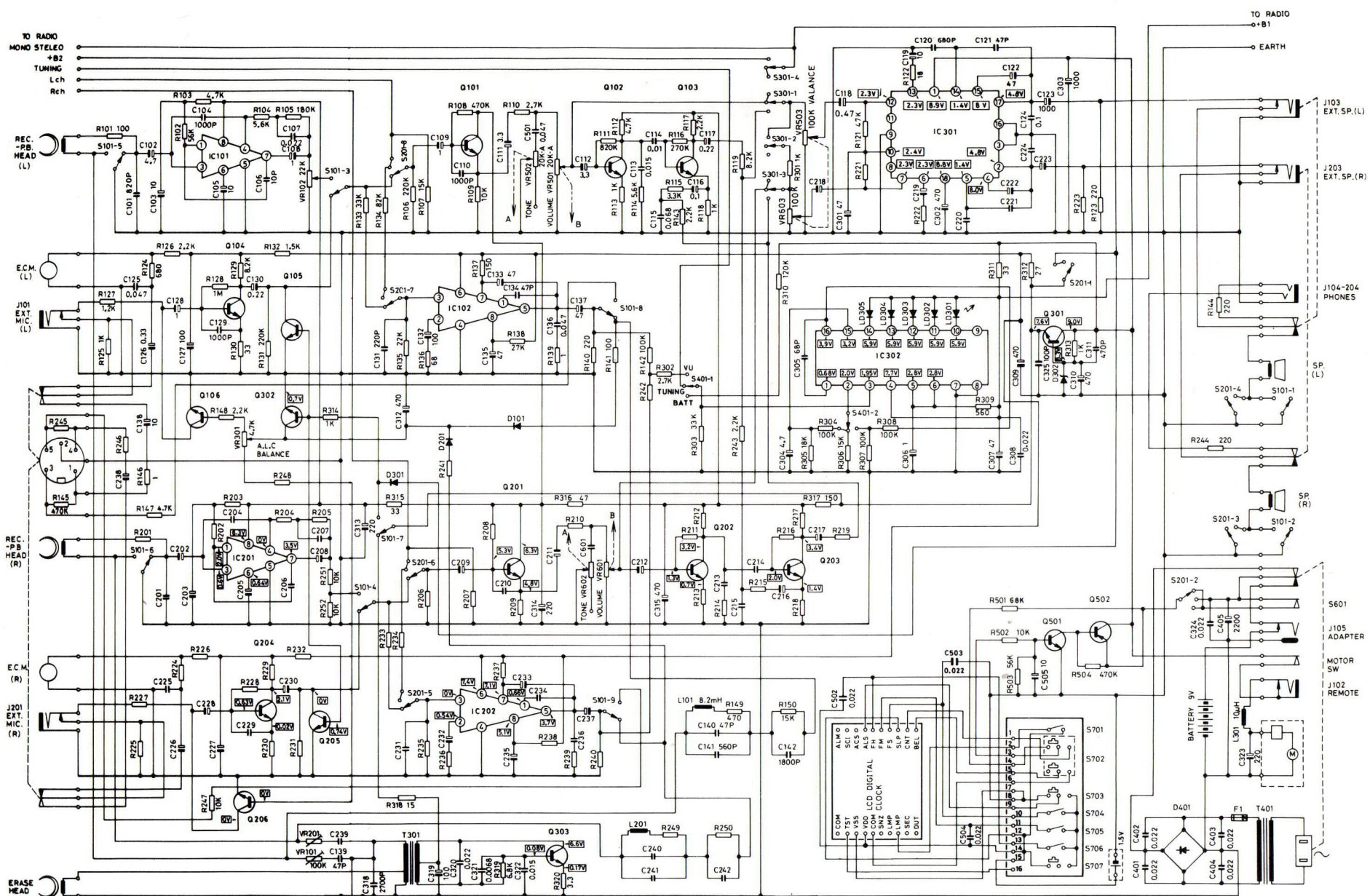

- Q101, 102, 103, 105, 106, 201, 202
- 203, 205, 206, 302, 501 - 25C458-D
- Q104, 204 - 25C1335-D
- Q301, 303 - 25D467-C
- Q202 - 25A634-L
- D101, 201, 301 - 1N4148
- D302 - UZ-8.2B
- D401 - T8A 820M
- L301, 302, 303
- 304, 305 - GL-105RE
- IC101, 201 - HA1406
- IC102, 202 - T8A 820M
- IC301 - AN7146M
- IC302 - LB1405

- S101 - REC/P.B. SWITCH (REC. POSITION)
- S301 - TAPE/RADIO/SLP SWITCH (TAPE POSITION)
- S301 - MONO/STEREO/WIDE SWITCH (STEREO POSITION)
- S401 - VU/BATT./TUNING SWITCH (VU POSITION)
- S501 - BEAT CANCEL
- S601 - TAPE ON OFF SWITCH (OFF POSITION)

- S701 LMP - LAMP SWITCH
- S702 M-A - MANUAL AUTO SWITCH
- S703 T-S - TIMER SET SWITCH
- S704 S - SECOND SWITCH
- S705 M - MINUTE SWITCH
- S706 H - HOUR SWITCH
- S707 FX - FIX SWITCH

NOTES:

1. ALL RESISTANCE VALUES ARE IN Ω . K=1000 Ω M=10000 Ω
2. ALL CAPACITANCE VALUES ARE IN μ . F=10 μ F
3. ALL RESISTORS ARE $\frac{1}{2}$ WATT UNLESS OTHERWISE SPECIFIED.
4. VOLTAGES MEASURED FROM POINT INDICATOR TO CHASSIS GROUND WITH VOLUME AT LINE VOLUME CONTROL MINIMUM AND NO SIGNAL.

(SPECIFICATIONS AND CIRCUITS SUBJECT TO CHANGE WITHOUT NOTICE IMPROVEMENT.)

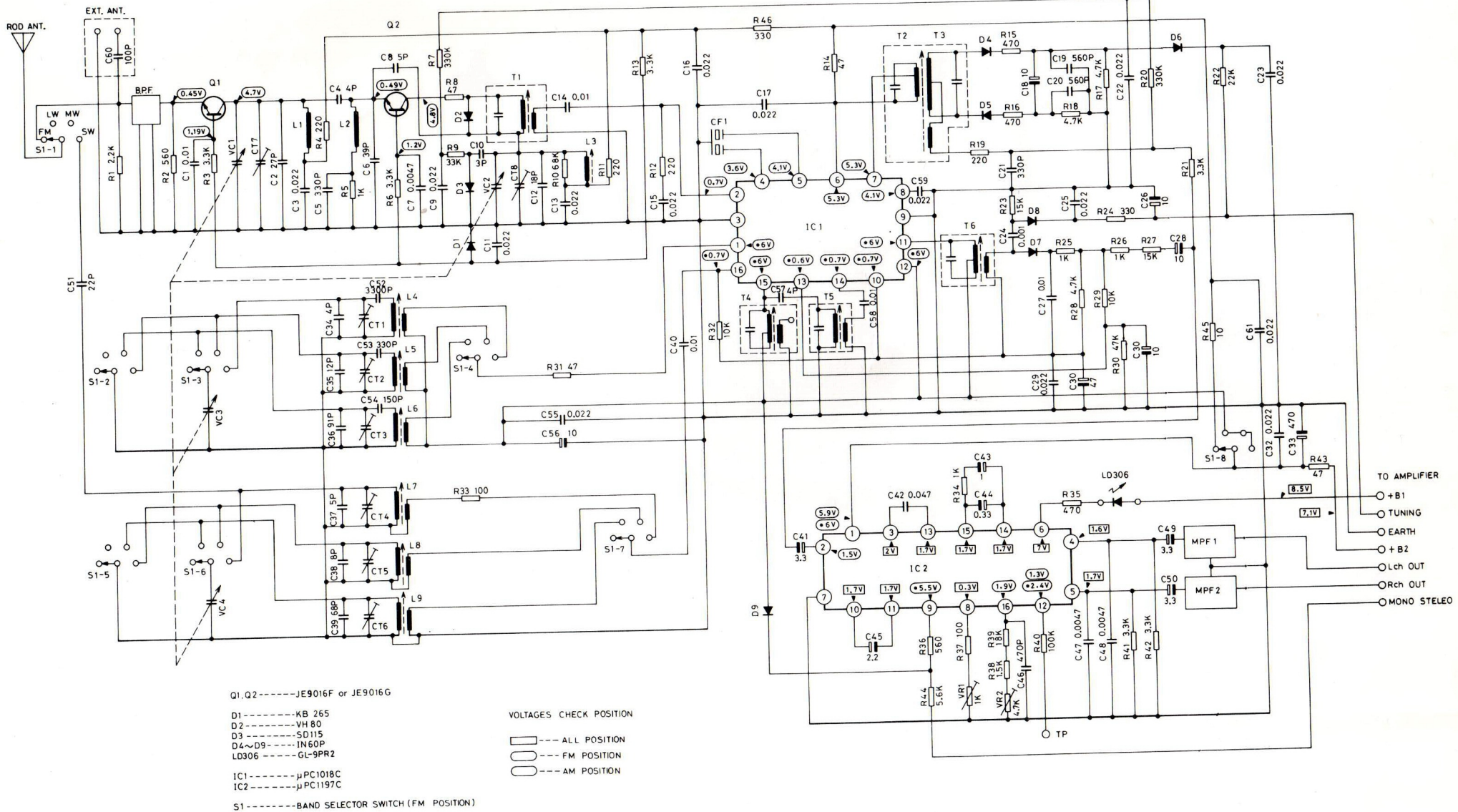

NOTES:
 1 ALL RESISTANCE VALUES ARE IN Ω . K=1000 Ω M=1000K Ω
 2 ALL CAPACITANCE VALUES ARE IN μ F. P=10 μ F
 3 ALL RESISTORS ARE 1/4 WATT, UNLESS OTHERWISE SPECIFIED
 4 VOLTAGES MEASURED FROM POINT INDICATOR TO CHASSIS GROUND WITH V.T.V.M AT LINE VOLUME CONTROL MINIMUM AND NO SIGNAL.
 (SPECIFICATIONS AND CIRCUITS SUBJECT TO CHANGE WITHOUT NOTICE IMPROVEMENT.)